

S9086-TX-STM-010

VOLUME 1
REVISION 5

NAVAL SHIPS' TECHNICAL MANUAL

CHAPTER 583

VOLUME 1 – BOATS AND SMALL CRAFT

THIS CHAPTER SUPERSEDES CHAPTER 583/R4 DATED 1 DEC 2001

DISTRIBUTION STATEMENT A: APPROVED FOR PUBLIC RELEASE, DISTRIBUTION IS UNLIMITED.

PUBLISHED BY DIRECTION OF COMMANDER, NAVAL SEA SYSTEMS COMMAND.

30 MAY 2006

REVISION RECORD

REVISION NO.	DATE	TITLE AND/OR BRIEF DESCRIPTION/PREPARING ACTIVITY
5	30 MAY 2006	

TABLE OF CONTENTS

Chapter/Paragraph	Page
583 BOATS AND SMALL CRAFT	1-1
SECTION 1 ADMINISTRATIVE POLICIES	1-1
583-1.1 INTRODUCTION.	1-1
583-1.1.1 BOATS AND SMALL CRAFT.	1-1
583-1.2 GENERAL INFORMATION.	1-1
583-1.2.1 DEFINITION OF A NAVY BOAT.	1-1
583-1.2.2 BOAT CORRESPONDENCE.	1-1
583-1.2.3 COMMERCIAL-OFF-THE-SHELF (COTS) BACKGROUND INFORMATION.	1-1
583-1.2.4 COMMERCIAL-OFF-THE-SHELF (COTS) PROCUREMENT POLICY. . .	1-1
583-1.3 STANDARD ALLOWANCE OF BOATS.	1-2
583-1.3.1 CNO AND PEO SHIPS PMS 325 ESTABLISHED BOAT LIST.	1-2
583-1.3.2 CHANGES IN BOAT ALLOWANCE.	1-2
583-1.3.3 BOATS ASSIGNED TO FLAGS AND COMMANDS.	1-2
583-1.3.4 HOW BOATS ARE OBTAINED.	1-2
583-1.3.5 EMERGENCY ISSUES.	1-2
583-1.4 TRANSFER OF BOATS.	1-2
583-1.4.1 PEO SHIPS PMS 325 AUTHORITY FOR TRANSFER OF BOATS.	1-2
583-1.4.2 TRANSFERRED WITH A FLAG.	1-3
583-1.4.3 TRANSFERS TO SPECIAL PROJECTS AND TEMPORARY LOANS. . .	1-3
583-1.4.4 TRANSFERS TO MILITARY ASSISTANCE PROGRAMS.	1-6
583-1.4.5 REPORTING TRANSFERS AND RECEIPTS.	1-6
583-1.4.5.1 Changes in Custody Status.	1-6
583-1.4.5.2 Issues.	1-6
583-1.4.5.3 Receipts.	1-6
583-1.4.5.4 Disposal.	1-6
583-1.4.5.5 Repairs.	1-6
583-1.4.6 BOAT SURVEYS AFLOAT.	1-6
583-1.5 TURN-IN PROCEDURES.	1-7
583-1.5.1 PEO SHIPS PMS 325 AUTHORITY FOR TURN-IN OF BOATS.	1-7
583-1.5.2 SURVEY REQUIREMENTS.	1-7
583-1.5.3 TURN-IN FOR STOCK.	1-7
583-1.5.3.1 Proper Boat Maintenance.	1-7
583-1.5.4 BOAT DISPOSAL.	1-7
583-1.5.5 PREPARATION FOR TURN-IN.	1-7
583-1.5.5.1 Removal of Hazardous Materials.	1-7
583-1.5.5.2 Preservation.	1-7
583-1.5.5.3 Certification.	1-7
583-1.5.6 RECEIPT INSPECTIONS.	1-8

TABLE OF CONTENTS - Continued

Chapter/Paragraph	Page
583-1.6 ALTERATIONS	1-9
583-1.6.1 CHANGES TO AUTHORIZED BOAT CONFIGURATIONS.	1-9
583-1.6.2 BOAT ALTERATION (BOATALT) RECORDS.	1-11
583-1.6.2.1 Numbering.	1-12
583-1.6.2.2 Boat/Craft Alteration (ALT).	1-12
583-1.6.3 ACCOMPLISHMENT.	1-12
583-1.6.3.1 Stock Boats.	1-12
583-1.6.3.2 Active Boats.	1-12
583-1.6.3.2.1 Repair Activities.	1-13
583-1.6.4 BOATALT ISSUANCE AND CANCELLATION.	1-13
583-1.6.5 AUTHORIZATION.	1-13
583-1.6.6 FUNDING.	1-13
583-1.6.6.1 Custodian or Command Support Activity Funds.	1-13
583-1.6.6.2 PEO SHIPS PMS 325 Boat Rehabilitation Funds.	1-13
583-1.6.7 EXPENDITURE OF FUNDS FOR UNAUTHORIZED ALTERATIONS.	1-14
583-1.6.8 DISTRIBUTION.	1-14
583-1.6.8.1 Distribution Requests.	1-14
583-1.6.9 COMPLETION RECORD.	1-14
583-1.6.10 REQUESTS FOR BOATALT ACCOMPLISHMENT BY BOAT CUSTODIANS.	1-15
583-1.6.11 CONVERSIONS.	1-15
583-1.6.11.1 Conversion Without BOATALT.	1-15
583-1.7 INSPECTION.	1-16
583-1.7.1 NEW BOATS.	1-16
583-1.7.1.1 Warranty Period.	1-16
583-1.7.1.2 Boat Receipt Inspection.	1-16
583-1.7.1.3 Unsatisfactory Inspection.	1-16
583-1.7.1.4 Acceptance Notification.	1-17
583-1.7.1.5 Estimating Costs.	1-17
583-1.7.2 BOATS IN STORAGE.	1-17
583-1.7.2.1 Pre-Issue Inspection.	1-20
583-1.7.2.2 Post Issue Rejection.	1-21
583-1.7.2.3 Non-RFI Issue.	1-21
583-1.8 PREPARATION FOR SHIPMENT	1-21
583-1.8.1 SHIPMENT DESTINATION.	1-21
583-1.9 SHIPMENT OF BOATS	1-22
583-1.9.1 PEO SHIPS PMS 325 SHIPMENT ORDER.	1-22
583-1.9.2 SHIPMENT PRECAUTIONS.	1-22
583-1.10 REPLACEMENT OF BOATS IN SERVICE	1-22
583-1.10.1 SERVICE LIFE FOR NAVY BOATS AND CRAFT.	1-22
583-1.10.2 REPAIR COST ESTIMATES.	1-23
583-1.10.3 TYPE OR AREA COMMANDER'S FUNDS FOR REPAIR.	1-23
583-1.10.4 REPAIRABILITY OF BOATS.	1-23

TABLE OF CONTENTS - Continued

Chapter/Paragraph	Page
583-1.10.5 ENGINE STATUS.	1-23
583-1.10.6 PREPARATION OF CRAFT AND BOATS TURNED IN FOR REPAIR OR STOCK.	1-23
583-1.11 STOCK CLASSIFICATION, LEVELS, AND DISTRIBUTION	1-23
583-1.11.1 STOCK CLASSIFICATION.	1-23
583-1.11.1.1 Issuable (Ready for Issue) (A Condition).	1-23
583-1.11.1.2 Repairable (F Condition).	1-24
583-1.11.1.3 Beyond Economical Repair (X Condition).	1-24
583-1.11.2 STOCK LEVELS.	1-24
583-1.11.2.1 Minimum Stock Levels.	1-24
583-1.11.2.2 Uneconomical Repair to Stock Boats.	1-24
583-1.11.2.3 Stock Boat Repairs.	1-24
583-1.11.3 STOCK DISTRIBUTION.	1-24
583-1.12 PRESERVATION, MAINTENANCE, AND REPAIR	1-24
583-1.12.1 PRESERVATION AND MAINTENANCE.	1-24
583-1.12.2 REPAIR.	1-24
583-1.12.3 COST.	1-24
583-1.12.4 ESTIMATING COSTS.	1-24
583-1.12.5 BOATS ASSIGNED TO SHIPS OR ACTIVITIES.	1-25
583-1.12.6 BOAT INSPECTION REPORT.	1-25
583-1.12.6.1 Inspection Report Use.	1-25
583-1.12.6.2 Routine Maintenance.	1-25
583-1.12.6.3 Inspection Report Use by Fleet Personnel.	1-25
583-1.12.6.4 Net Cost.	1-25
583-1.12.6.5 Local Repair Authorization.	1-26
583-1.12.6.6 Gross Cost.	1-26
SECTION 2 DIMENSIONS, WEIGHTS, AND CHARACTERISTICS	2-1
583-2.1 STANDARD NAVY BOATS	2-1
583-2.1.1 DIMENSIONS, WEIGHTS AND CHARACTERISTICS.	2-1
583-2.1.2 WEIGHT REPORTING.	2-1
583-2.2 REFERENCE FOR OPERATING PERSONNEL	2-1
583-2.2.1 IMPORTANT CHARACTERISTICS.	2-1
583-2.3 PAINT PUNT PURCHASE DESCRIPTION	2-1
583-2.3.1 PAINT PUNT.	2-1
SECTION 3 REGISTRY NUMBERS AND IDENTIFICATION MARKINGS	3-1
583-3.1 REGISTRY NUMBERS	3-1
583-3.1.1 NAVSEA ASSIGNED REGISTRY NUMBERS.	3-1
583-3.1.2 APPLICATION FOR REGISTRY NUMBER FROM NAVSEA.	3-1

TABLE OF CONTENTS - Continued

Chapter/Paragraph	Page
583-3.2 IDENTIFICATION MARKINGS	3-1
583-3.2.1 STANDARD MARKINGS.	3-1
583-3.2.1.1 Flag Officer	3-2
583-3.2.1.2 Unit Commander.	3-2
583-3.2.1.3 Chief of Staff.	3-2
583-3.2.1.4 Commanding Officer.	3-3
583-3.2.1.5 Ships' Boats.	3-3
583-3.2.1.6 Miscellaneous.	3-3
583-3.2.2 BOATS AND CRAFT ASSIGNED TO SHORE STATIONS.	3-3
583-3.2.2.1 Shore Station.	3-3
583-3.2.2.2 Shore Based Command.	3-3
583-3.2.3 IDENTIFICATION MARKINGS FOR COMBATANT CRAFT.	3-3
583-3.2.3.1 Painting.	3-3
 SECTION 4 BOAT CAPACITY, OPERATING INSTRUCTIONS AND SAFETY	
PRECAUTIONS	4-1
583-4.1 BOAT CAPACITY	4-1
583-4.1.1 BOAT REGISTRY AND BOATALT LABEL PLATES.	4-1
583-4.1.1.1 Registry Plate Format.	4-1
583-4.1.1.2 Drawing Number.	4-1
583-4.1.1.3 Commercial-Off-The-Shelf (COTS) Boat Drawings.	4-1
583-4.1.2 DETERMINATION OF CARRYING CAPACITIES.	4-1
583-4.1.2.1 Boats and Craft.	4-1
583-4.1.3 WEIGHT CONSIDERATIONS.	4-1
583-4.1.4 CAPACITY NOT TO BE EXCEEDED.	4-2
583-4.1.4.1 Flotation Material.	4-2
583-4.1.5 HANDLING OF STORES.	4-2
583-4.1.6 REDUCTION IN CAPACITY.	4-2
583-4.2 OPERATING INSTRUCTIONS	4-3
583-4.2.1 INTERNAL BUOYANCY OF LIFE RAFTS.	4-3
583-4.2.2 LIFE PRESERVERS STOWED IN BOATS.	4-3
583-4.3 BOATS AND SMALL CRAFT FIRE HAZARDS	4-3
583-4.3.1 LIST OF FIRE HAZARDS.	4-3
583-4.3.2 GASOLINE.	4-4
583-4.3.2.1 Containers.	4-4
583-4.3.3 CLOTHING AND OILY WASTE OR RAGS.	4-4
583-4.3.4 FUEL LEAKS.	4-4
583-4.3.4.1 Shutoff Valves.	4-4
583-4.3.4.2 Fuel Tanks.	4-4
583-4.3.4.3 Components of the Fuel System.	4-4
583-4.3.4.4 Stowages.	4-4
583-4.3.5 VENTILATION.	4-4
583-4.3.5.1 Leakage.	4-4
583-4.3.5.2 Gasoline Vapor.	4-5

TABLE OF CONTENTS - Continued

Chapter/Paragraph		Page
	583-4.3.5.3 Vapor in Bilges.	4-5
	583-4.3.5.4 Explosive Sparks.	4-5
583-4.3.6	FUELING.	4-5
	583-4.3.6.1 In the Skids.	4-5
	583-4.3.6.2 Passengers Aboard.	4-5
	583-4.3.6.3 At Night.	4-5
	583-4.3.6.4 Heat Producing Sources.	4-5
	583-4.3.6.5 Drums and Containers.	4-6
	583-4.3.6.6 Grounding Wire.	4-6
	583-4.3.6.7 Passing a Drum to Boat.	4-6
	583-4.3.6.8 Fueling Procedures.	4-6
	583-4.3.6.9 Before Starting Engine.	4-7
	583-4.3.6.10 Shore Station Fueling.	4-7
	583-4.3.6.11 Lighting.	4-8
	583-4.3.6.12 Flame Screen.	4-8
583-4.3.7	BILGES AND SUMPS.	4-8
583-4.3.8	EXHAUST PIPE.	4-8
583-4.3.9	DIRTY ENGINES.	4-8
583-4.3.10	DEFECTIVE ELECTRICAL WIRING.	4-8
583-4.3.11	BATTERY CHARGING.	4-8
583-4.4	5SAFETY PRECAUTIONS	4-9
	583-4.4.1 GASOLINE VAPOR.	4-9
	583-4.4.2 CLOSED ENGINE ROOM.	4-9
	583-4.4.3 ELECTRIC CONNECTIONS.	4-9
	583-4.4.4 FUEL PIPING AND TANK FITTING.	4-9
	583-4.4.5 WIRE GAUZE SCREENS.	4-9
	583-4.4.6 ARBURETOR DRIP PAN (GASOLINE ENGINES ONLY).	4-9
	583-4.4.7 BILGES AND SUMPS.	4-9
	583-4.4.8 VENTILATION.	4-9
	583-4.4.9 SAFETY INSTRUCTIONS.	4-10
	583-4.4.10 LIQUEFIED GAS.	4-10
	583-4.4.11 SIGNAL FLARES.	4-10
	583-4.4.12 FIRE RESISTANT HOSE.	4-10
SECTION 5	EQUIPMENT AND REPAIR PARTS	5-1
583-5.1	GENERAL.	5-1
	583-5.1.1 BOAT EQUIPMENT AND OUTFIT.	5-1
	583-5.1.1.1 Boat Equipment.	5-1
	583-5.1.1.2 Allowance Parts List (APL).	5-2
	583-5.1.1.3 Outfit Items.	5-2
	583-5.1.1.4 Allowance Equipage List (AEL).	5-2
	583-5.1.2 PROCUREMENT OF OUTFIT AND MAINTENANCE PARTS.	5-2
	583-5.5.1.2 Funding.	5-2
	583-5.1.3 DISPOSITION OF OUTFIT AND MAINTENANCE PARTS.	5-3
	583-5.1.4 REPLACEMENT ENGINES.	5-3

TABLE OF CONTENTS - Continued

Chapter/Paragraph	Page
583-7.6.2 REPAIR ACTIVITIES' RECORD OF INSPECTIONS AND TESTS.	7-6
583-7.7 SIDE GUYS.	7-6
583-7.7.1 GENERAL.	7-6
583-7.7.2 RIGGING FIBER LINE SIDE GUYS.	7-6
SECTION 8 MAINTENANCE	8-1
583-8.1 INTRODUCTION.	8-1
583-8.1.1 PLANNED MAINTENANCE SYSTEM.	8-1
583-8.1.1.1 Maintenance Support Documentation.	8-1
583-8.1.1.2 Camouflage Paint Requirements.	8-1
583-8.2 WOOD BOATS.	8-1
583-8.3 ALUMINUM BOATS.	8-1
583-8.3.1 GENERAL.	8-1
583-8.3.2 ALLOYS.	8-1
583-8.3.2.1 General Purpose and Other Alloys.	8-1
583-8.3.2.2 Tempers.	8-2
583-8.3.2.3 General Characteristics.	8-2
583-8.3.2.3.1 Galvanic Corrosion.	8-2
583-8.3.2.3.2 Galvanic Corrosion Locations.	8-2
583-8.3.2.3.3 Cleanliness.	8-3
583-8.3.2.4 Metal Working.	8-3
583-8.3.2.4.1 Forming Annealed Alloys.	8-3
583-8.3.2.4.2 Forming Strain Hardened Alloys.	8-3
583-8.3.2.4.3 Reforming Damaged Parts.	8-3
583-8.3.2.4.4 Facilitating Repair.	8-4
583-8.3.3 PAINTING.	8-4
583-8.3.3.1 Exterior Boottopping and Above.	8-4
583-8.3.3.2 Deck.	8-4
583-8.3.3.2.1 Magnesium Castings.	8-5
583-8.3.3.3 Underwater Hull on Boats That Require an Antifouling Coating System.	8-5
583-8.3.3.3.1 Preparation.	8-5
583-8.3.3.3.2 Application.	8-5
583-8.3.3.4 Bilges.	8-6
583-8.3.3.5 Tank Cleaning and Maintenance.	8-6
583-8.3.4 CATHODIC PROTECTION.	8-6
583-8.3.4.1 Anodes.	8-6
583-8.3.4.2 Depleted Anodes.	8-6
583-8.3.4.3 Installation.	8-7
583-8.3.5 PIPING SYSTEMS.	8-8
583-8.3.5.1 Joint Corrosion.	8-8
583-8.3.5.2 Seacocks.	8-8
583-8.3.5.3 Lubricating Aluminum Fittings.	8-8

TABLE OF CONTENTS - Continued

Chapter/Paragraph		Page
583-8.3.5.4	Pipe Hangers.	8-9
583-8.3.5.4.1	Insulating Dissimilar Metal Lines.	8-9
583-8.3.5.4.2	Steel Hangers.	8-9
583-8.3.5.5	Bulkhead Penetration.	8-9
583-8.3.5.5.1	Watertight Bulkheads.	8-9
583-8.3.5.5.2	Dissimilar Metal Piping System.	8-9
583-8.3.5.6	Pipe Insulation.	8-9
583-8.3.6	MACHINERY, SHAFTING, AND PROPELLERS.	8-9
583-8.3.6.1	Shock Mounting.	8-10
583-8.3.6.2	Stuffing Boxes.	8-10
583-8.3.6.3	Shaft Logs.	8-10
583-8.3.6.3.1	Inspection.	8-10
583-8.3.6.3.2	Shaft Buildup.	8-10
583-8.3.6.3.3	Plasma Spray Heating Process.	8-10
583-8.3.6.4	Propeller Shafting.	8-10
583-8.3.6.5	Shaft Bearings.	8-10
583-8.3.7	TANKS.	8-10
583-8.3.7.1	Freshwater Tanks.	8-11
583-8.3.7.2	Fuel Tanks.	8-11
583-8.3.7.3	Collection Holding Tanks (CHT).	8-11
583-8.3.8	MOORING AND TOWING DECK FITTINGS.	8-11
583-8.3.8.1	Dissimilar Metal Fittings.	8-11
583-8.3.9	DECK EQUIPMENT AND MACHINERY.	8-11
583-8.3.9.1	Deck Equipment Reinstallation.	8-11
583-8.3.10	ADDITIONAL REQUIREMENTS.	8-11
583-8.3.10.1	Mooring.	8-12
583-8.3.10.2	Shore Power.	8-12
583-8.3.10.2.1	With Isolation Transformer.	8-12
583-8.3.10.2.2	Without Isolation Transformer.	8-12
583-8.3.10.2.3	Electrical Shore Facilities.	8-12
583-8.3.10.2.4	Gangways and Welding Machines.	8-12
583-8.3.10.2.5	Ground.	8-12
583-8.3.10.2.6	Stray Current.	8-12
583-8.3.10.2.7	Isolating Welding Sets.	8-12
583-8.3.10.2.8	Battery Chargers.	8-13
583-8.3.10.3	Field Attachments.	8-13
583-8.3.10.4	Bilge Flush.	8-13
583-8.3.10.5	Cavitation Corrosion.	8-13
583-8.3.10.6	Drydocking.	8-13
583-8.3.10.6.1	Bilge Area.	8-13
583-8.3.10.6.2	Bilge Zinc Anodes.	8-13
583-8.3.10.6.3	Exterior Hull Surface.	8-13
583-8.4	STEEL BOATS.	8-14
583-8.4.1	PAINING, SAND-BLASTING, AND SCRAPING.	8-14
583-8.4.2	CATHODIC PROTECTION.	8-14
583-8.4.3	STRAY CURRENT PROTECTION.	8-14

TABLE OF CONTENTS - Continued

Chapter/Paragraph	Page
583-8.5 GLASS REINFORCED PLASTIC BOATS.	8-14
583-8.5.1 GLASS REINFORCED PLASTIC BOAT HULLS.	8-14
583-8.5.2 GLASS REINFORCED PLASTIC BOAT CONSTRUCTION.	8-14
583-8.5.3 GLASS REINFORCED PLASTIC BOAT CONSTRUCTION TYPES.	8-14
583-8.5.4 CONSTRUCTION BONDING.	8-14
583-8.5.5 ATTACHMENT AND SUPPORT OF L OR T SHAPES.	8-15
583-8.5.6 PAINT REMOVAL	8-15
583-8.5.7 PREVENTIVE MAINTENANCE.	8-15
583-8.5.7.1 Inspection.	8-15
583-8.5.7.1.1 Bolts and Fasteners.	8-15
583-8.5.7.1.2 Defective Fasteners.	8-15
583-8.5.7.2 Craze Marks.	8-15
583-8.15.7.3 Deformation.	8-15
583-8.5.7.4 Flotation Material.	8-15
583-8.5.7.5 Loose Fastenings.	8-16
583-8.5.7.6 Propeller, Shaft, and Strut.	8-16
583-8.6 CATHODIC PROTECTION OF BOATS.	8-16
583-8.6.1 ZINC ANODES INSTALLATION.	8-16
583-8.7 ENGINE MAINTENANCE	8-16
583-8.7.1 ENGINE MAINTENANCE.	8-16
583-8.7.2 ENGINE MAINTENANCE RESPONSIBILITY.	8-16
583-8.8 GUIDANCE FOR FLEET PERSONNEL ON PREVENTIVE MAINTENANCE AND REPAIR OF BOATS AND LANDING CRAFT.	8-17
583-8.8.1 INITIAL INSPECTIONS.	8-17
583-8.8.2 REFERENCE MATERIAL.	8-17
SECTION 9 PRESERVATION, STORAGE, AND DEPRESERVATION OF BOATS ASHORE	9-1
583-9.1 INTRODUCTION	9-1
583-9.1.1 STOCK BOATS.	9-1
583-9.1.2 REPAIRABLE OR ISSUABLE STOCK BOATS.	9-1
583-9.1.3 REMOVAL OF ENGINES FROM STOCK BOATS.	9-1
583-9.1.4 STOCK BOATS CHECKOFF LIST.	9-1
583-9.2 PRESERVATION PROCEDURES	9-1
583-9.2.1 CUSTODIAN RESPONSIBILITIES FOR PRESERVATION.	9-1
583-9.2.2 BOAT ENGINE, REVERSE GEAR, AND PROPULSION UNIT PRESERVATION.	9-2
583-9.2.2.1 Motoring Engine.	9-2
583-9.2.3 STEEL HULLS.	9-3
583-9.2.4 PLASTIC HULLS.	9-4
583-9.3 INVENTORY CONTROL POINT (ICP) RESPONSIBILITIES FOR STORAGE.	9-4

TABLE OF CONTENTS - Continued

Chapter/Paragraph	Page
583-9.4 DEPRESERVATION.	9-4
583-9.4.1 INVENTORY CONTROL POINT (ICP) POINT RESPONSIBILITIES FOR DE-PRESERVATION.	9-4
583-9.4.2 CUSTODIAN OR RECEIVING ACTIVITY RESPONSIBILITIES FOR DEPRESERVATION.	9-4
583-9.4.3 STARTING DIESEL ENGINES AFTER DEPRESERVATION.	9-5
583-9.4.3.1 Lubrication System.	9-5
583-9.4.3.2 Fuel System.	9-5
583-9.4.3.3 Cooling System.	9-5
SECTION 10 BARGES AND GIGS	10-1
583-10.1 CONVERSION OF STANDARD BOATS.	10-1
583-10.1.1 STANDARD ITEMS APPROVAL AND INSTALLATIONS.	10-1
583-10.2 STANDARD ITEMS.	10-1
583-10.2.1 CONVERSION OF STANDARD BOATS TO BARGES AND GIGS.	10-1
583-10.2.2 STANDARD ITEMS APPROVAL AND FUNDING.	10-1
583-10.2.3 PAINTING OF BARGES AND GIGS.	10-1
SECTION 11 SPECIAL MISSION BOATS ANTI TERRORISM/FORCE PROTECTION AND SPECIAL MISSION BOATS AND CRAFT	11-1
583-11.1 GENERAL INFORMATION	11-1
583-11.2 FORCE PROTECTION/ANTI TERRORISM BOAT TYPES	11-1
583-11.2.1 SHARBOR SECURITY (HS) AND PATROL BOATS (PB).	11-1
583-11.2.2 LINE HANDLING BOATS.	11-1
583-11.2.3 BARRIER BOATS (BB).	11-1
583-11.2.4 ESCORT BOATS	11-1
583-11.3 FORCE PROTECTION/ANTI TERRORISM HULL CONSTRUCTION.	11-1
583-11.3.1 COLLAR TYPES.	11-1
583-11.4 ENGINES.	11-1
583-11.4.1 PROPULSION UNITS.	11-1
SECTION 12 LIFE RAFTS AND ABANDON SHIP BOAT	12-1
583-12.1 INTRODUCTION.	12-1
583-12.1.1 GENERAL.	12-1
583-12.1.2 TYPES OF INFLATABLE LIFE RAFTS.	12-1
583-12.1.3 LIFE RAFT SPECIFICATIONS.	12-1
583-12.1.4 ABANDON SHIP BOAT.	12-1
583-12.2 ALLOWANCES AND ISSUES.	12-2
583-12.2.1 CORRESPONDENCE.	12-2

TABLE OF CONTENTS - Continued

Chapter/Paragraph	Page
583-12.2.2 STANDARD SHIPBOARD ALLOWANCE.	12-2
583-12.2.3 CHANGES IN ALLOWANCE.	12-3
583-12.2.4 HOW RAFTS ARE OBTAINED.	12-3
583-12.3 REPORTS.	12-3
583-12.3.1 MAJOR REPAIR REPORTS.	12-3
583-12.3.2 LIFE RAFT TURN-IN OR EXCHANGE.	12-3
583-12.3.3 RECEIPT OF NEW LIFE RAFT REPORT.	12-3
583-12.4 DISPOSALS AND SURVEYS.	12-3
583-12.4.1 DISPOSAL OF LIFE RAFTS.	12-3
583-12.4.2 REPLACEMENT AT END OF 25-YEAR SERVICE LIFE.	12-3
583-12.4.3 LOSS OF LIFE RAFT AT SEA.	12-4
583-12.4.4 CERTIFIED AND REPAIR FACILITIES DISPOSAL OF LIFE RAFTS. . .	12-4
583-12.4.5 LIFE RAFTS FROM SHIPS BEING DEACTIVATED.	12-4
583-12.5 STOCK CLASSIFICATION, LEVELS, AND DISTRIBUTION.	12-4
583-12.5.1 CLASSIFICATION.	12-4
583-12.5.1.1 Condition A.	12-4
583-12.5.1.2 Condition F.	12-4
583-12.5.1.3 Condition H.	12-4
583-12.5.1.4 Condition M.	12-4
583-12.5.2 STOCK LEVELS.	12-4
583-12.5.3 DISTRIBUTION.	12-4
583-12.5.3.1 Repair Priority.	12-4
583-12.5.3.2 Estimated Repair Costs.	12-4
583-12.6 IDENTIFICATION.	12-4
583-12.6.1 LIFE RAFT REGISTRY NUMBER.	12-4
583-12.7 CAPACITIES, WEIGHTS, AND DIMENSIONS.	12-5
583-12.7.1 LIFE RAFT CHARACTERISTICS.	12-5
583-12.7.2 CONTAINER DESIGN.	12-5
583-12.8 EQUIPMENT AND REPAIR PARTS.	12-5
583-12.8.1 SURVIVAL GEAR AND REPAIR PARTS FOR MK 6, MK 7, AND MK 8 LIFE RAFTS.	12-5
583-12.8.2 LIST OF SURVIVAL GEAR FOR EACH TYPE LIFE RAFT.	12-5
583-12.9 STOWAGE AND HANDLING.	12-7
583-12.9.1 STOWAGE.	12-7
583-12.9.1.1 Hydrostatic Release.	12-7
583-12.9.1.2 Sea Painter.	12-7
583-12.9.2 HANDLING.	12-7
583-12.9.2.1 Covered Storage.	12-7
583-12.10 INSPECTION	12-7

TABLE OF CONTENTS - Continued

Chapter/Paragraph	Page
583-12.10.1 TYPES OF PERIODIC MAINTENANCE.	12-7
583-12.10.2 STOWAGE SECURING HARNESS.	12-8
583-12.10.2.1 Hydrostatic Release.	12-8
583-12.10.2.1.1 Hydrostatic Release Installation.	12-8
583-12.10.2.1.2 Securing Sea Painter.	12-8
583-12.10.2.1.3 Inspect The Stowage Location.	12-8
583-12.10.2.1.4 Inspection and Test.	12-8
583-12.10.3 DEPOT LEVEL.	12-8
583-12.11 SERVICING AND MAINTENANCE.	12-9
583-12.11.1 SERVICING.	12-9
583-12.11.1.1 Repair	12-9
583-12.11.1.2 Maintenance.	12-9
583-12.12 RAFT CERTIFICATION AND EXCHANGE.	12-9
583-12.12.1 INSPECTION, CERTIFICATION AND EXCHANGE.	12-9
583-12.12.2 TEST OF THE HYDROSTATIC RELEASE.	12-9
583-12.12.2.1 Can-Type Hydrostatic Release.	12-9
583-12.12.2.2 Can Measurement.	12-10
A Technical Manual Deficiency/Evaluation Report(TMDER)	12-5

LIST OF TABLES

Table	Title	Page
583-1-5	Boat Check List	1-17
583-2-1	Characteristics For Navy Boats And Craft	2-3
583-10-1	Standard Items for Barges and Gigs	10-1
583-10-2	Recommended Colors for Barges and Gigs	10-3
583-12-1	Abandon Ship Survival Bag Equipment ¹	12-2
583-12-2	Characteristics for Inflatable Life Rafts	12-5
583-12-3	Table 583-12-3. Survival Gear	12-5

S9086-TX-STM-010

LIST OF ILLUSTRATIONS

Figure	Title	Page
583-1-1s1	Boat Inspection Report NAVSEA 9583/series (Sheet 1 of 2)	1-4
583-1-1s2	Boat Inspection Report NAVSEA 9583/series (Sheet 2 of 2)	1-5
583-1-2	Sample Certification of Boat Ready for Turn-In Letter with Boat Ready for Turn-In Certification Form	1-8
583-1-3	Boat Alteration Request Form	1-11
583-1-4	Boat Alteration Label Plate	1-15
583-3-1	Hull Registry Numbers a.	3-2

CHAPTER 583

BOATS AND SMALL CRAFT

SECTION 1

ADMINISTRATIVE POLICIES

583-1.1 INTRODUCTION.

583-1.1.1 BOATS AND SMALL CRAFT. Chief of Naval Operations (CNO), OPNAVINST 4780.6D, provides policy for Boats and Craft of the US Navy. Chapter 583 discusses the administrative procedures which follow CNO policy, including description, maintenance, handling equipment, and repair of boats and small craft. In addition, operating procedures, safety precautions, testing and inspection requirements are covered to provide convenient reference and reduce interpretation errors concerning boats, boat handling and stowage systems.

583-1.2 GENERAL INFORMATION.

583-1.2.1 DEFINITION OF A NAVY BOAT. Navy boats are National Defense Property and are centrally procured, managed, and tracked, by Program Executive Office, Ships, Program Management, Ships 325 (PEO SHIPS PMS 325). The boat may be assigned to and carried on a ship as a ship's boat or assigned to a shore station or fleet operating unit.

583-1.2.2 BOAT CORRESPONDENCE. All correspondence related to boats should cite the boat length, type, and the U.S. Navy hull registry number, not the local number assigned by the command, ship, or station.

583-1.2.3 COMMERCIAL-OFF-THE-SHELF (COTS) BACKGROUND INFORMATION. Commercial-off-the-shelf (COTS) products are the preferred alternative for the development of defense systems when existing military products cannot meet real time operational requirements. Integration of COTS allows for faster and lower cost production of defense equipment and supplies through the use of commercial manufacturing and technologies which are crucial if the nation has to expand production to reconstitute forces in response to new threats. While the integration allows for real time acquisition it introduces complexities and risks into the development, acquisition, budgeting, engineering, and support processes including risks imposed by the rapid pace of technological changes and the lack of complete design disclosure requiring strategies, plans, and budgets addressing the additional risks. Integration of COTS requires extensive knowledge of the "best practices" for the development, acquisition, modernization, and maintenance of affordable ships and systems utilizing commercial items. The changes in technology requires NAVSEA and the affiliated PEO SHIPS PMS 325 Program Managers (PM) to plan and budget for the future replacement and updates of COTS products throughout the life cycle of deployed equipment.

583-1.2.4 COMMERCIAL-OFF-THE-SHELF (COTS) PROCUREMENT POLICY. Navy boats and craft are centrally procured and managed by PMS 325 in accordance with (IAW) OPNAVINST 4780.6. COTS procurement is fiscally responsible because:

- a. It ensures each boat has a requirement minimizing redundancy and waste.

S9086-TX-STM-010

- b. It combines requirements thereby taking advantage of economics of scale while ensuring each boat meets its operational requirements.
- c. It reduces acquisition time and costs in addition to reduced boat costs.
- d. It permits expansion of the base of COTS boats that are capable of meeting real operational requirements. Activities are not authorized to procure boats without specific written authorization from PEO SHIPS PMS 325 regardless of the cost.

583-1.3 STANDARD ALLOWANCE OF BOATS.

583-1.3.1 CNO AND PEO SHIPS PMS 325 ESTABLISHED BOAT LIST. The allowance of boats for forces afloat is established by the CNO and for shore stations by Program Executive Officer, PEO SHIPS PMS 325, according to OPNAVINST 4780.6 series.

583-1.3.2 CHANGES IN BOAT ALLOWANCE. Any request for a change in the boat allowance of the ship or shore station should be the subject of a letter request (message, in an emergency) clearly stating the reasons for the change. This letter request should be addressed to CNO or PEO SHIPS PMS 325 as appropriate and forwarded through the requester's chain of command for validation. The CNO will determine if the allowance change is approved or disapproved, and will issue necessary instructions and funds to PEO SHIPS PMS 325. The letter requesting the increase, decrease or establishment of a boat allowance should cite the boat type, length and intended end use, operational requirements, and justification.

583-1.3.3 BOATS ASSIGNED TO FLAGS AND COMMANDS. Boats for Flag Officers and Commands will be authorized only by CNO. When assigned, these boats are not part of any ship's allowance but are in the custody of the flag. Boats assigned for personal use of flag officers are referred to as barges. Boats assigned for personal use of Chiefs of Staff, Squadron, Group, and Division Commanders, not of flag rank, and for Commanding Officers are referred to as gigs. When referring to such boats in correspondence addressed to PEO SHIPS PMS 325, they should also be designated by length, type, and hull registry number. Assignment and management criteria for barges and gigs are set forth in OPNAVINST 4780.6 series. By definition the user command is responsible for the administration, operation, manning, safety, security, development and submission of the budgets needed to perform maintenance, stock repair parts, and for the establishment of maintenance policies within current policy and guidelines.

583-1.3.4 HOW BOATS ARE OBTAINED. Boats are PEO SHIPS PMS 325 special material and are not subject to standard requisitioning procedures. Under normal conditions, boats are obtained by letter request to PEO SHIPS PMS 325 citing the justification, operational requirements, and intended end use. In an emergency, requests may be submitted by naval message or telephone. Telephone requests should be confirmed by a follow-up message.

583-1.3.5 EMERGENCY ISSUES. Boats should not be issued or disposed of without specific authority from PEO SHIPS PMS 325, except in an emergency. When issues must be made without approval, PEO SHIPS PMS 325 should be given full details at the earliest date by letter or message.

583-1.4 TRANSFER OF BOATS.

583-1.4.1 PEO SHIPS PMS 325 AUTHORITY FOR TRANSFER OF BOATS. Boats should not be transferred, unless an emergency exists, without specific authority from PEO SHIPS PMS 325. Custodians may assign boats

on sub-custody to neighboring activities when a temporary need arises. When transfers must be made without prior approval, PEO SHIPS PMS 325 shall be given full details at the earliest date by letter or message.

583-1.4.2 TRANSFERRED WITH A FLAG. Boats assigned for personal use of flag officers afloat or their staffs, may be transferred from ship to ship, with the flag, without specific authority of PEO SHIPS PMS 325. However, PEO SHIPS PMS 325 should be advised of the date of the transfer by letter or message citing the names of the ships involved and hull registry numbers of each.

583-1.4.3 TRANSFERS TO SPECIAL PROJECTS AND TEMPORARY LOANS. Boats may be assigned by PEO SHIPS PMS 325 to special projects such as disaster relief or environmental cleanup efforts. These boats may be operated by other government agencies or commercial corporations. The recipient temporary boat custodian is responsible for restoration of the boat to as-issued condition upon return to U.S. Navy custody. Receipt of U.S. Navy issue boats shall be reported by the most expeditious record means within 5 days of boat arrival at the new custodial activity. A completed Boat Inspection Report (NAVSEA 9583/series) (Figure 583-1-1) shall be completed by a NAVSEA designated boat surveyor before turn back/acceptance. This completed form will be used by PEO SHIPS PMS 325 to determine the financial liability of the user custodian from funds allotted to the special project.

BOAT INSPECTION REPORT
CCD 2311/1 FROM NAVSEA 9583/2

(Insert appropriate letter/symbol in space provided;
"✓" = Acceptable, "R" = Repair, "X" = Replace, "T" = Test; and "*" = Cosmetic/Maintenance

-Page 1 of 2-

Boat Type:	Engine Type:	Hull No:	Configuration: STD	Date:
HULL EXTERIOR	HULL INTERIOR (cont'd)	HULL TOPSIDE (cont'd)	PIPING (cont'd)	AUXILIARY EQUIP (cont'd)
BOW/STEM	CARGO FLAT	HAND RAILS*		
PORT GUNWALE	COXSWAIN FLAT	LIFE LINES*		
PORT SIDE	CUSHIONS*	TAFF RAILS*		
PORT RUBRAIL	DOORS	TOE RAILS	Subtotal	
PORT CHINE	ENGINE COVER	PILOT HOUSE	MAIN PROPULSION	Subtotal
PORT BOTTOM	FLOTATION	PAINT*	ENGINE	ELECTRICAL SYSTEMS
KEEL/SKEG	FLOORS		REVERSE GEAR	WIRING
STBD GUNWALE	HATCHES		V-DRIVE	DIST PANEL
STBD SIDE	LIFTING PADS	Subtotal *	TRANSMISSION	SWITCHBOARDS
STBD RUBRAIL	LOCKERS	PIPING SYSTEMS	OUT DRIVE	LIGHTS-NAVI*
STBD CHINE	MAN HOLES	BILGE PIPING	OUTBOARD ENGINE	LIGHTS-INTER*
STBD BOTTOM	SEATS* (MAJOR)	BILGE VALVES	ALTERNATOR	BATTERY CABLES*
TRANSOM	VOIDS	FW PIPING	STARTER	HORN*
TRANSOM CORNERS	PAINT*	FW VALVES	PUMP-FW	SPOTLIGHT*
PROPELLER*		SW PIPING	PUMP-SW	FANS*
RUDDER		SW VALVES	SAND TRAP	WINDSHIELD WIPERS*
SHAFT*		LO PIPING	HEAT EXCHANGER	
STRUT	Subtotal *	FO PIPING	THROTTLE CONTROLS	Subtotal *
STRUT BRG*	HULL TOPSIDE	FO VALVES	SHIFTING LINKAGE	INSTRUMENTS & GAUGES
STUFFING BOX	CABIN TOP	EXHAUST SYSTEM		VOLTMETER*
ZINCS*	CABIN SIDES	MUFFLERS		OIL PRESSURE ENG*
RAMP	CANOPY FITTINGS	KEEL COOLER		OIL PRESSURE REVGR*
RAMP HINGE	CANOPY	STRAINERS	Subtotal	OIL TEMP*
RAMP GASKET	CHOCKS*	FILTER-FO	AUXILIARY EQUIPMENT	WATER TEMP*
SAND BLAST	CLEATS*	FILTER-LO	AIR COMPRESSOR	HYD PRESSURE*
SCRAPE/SAND	COAMINGS	HOSES	WINDLASS	HYD TEMP*
PAINT*	DECK	SEACOCKS	CAPSTAN	TACHOMETER*
	DECK COVERING	ACCUMULATORS	CRANES	
	WINDOWS/PORTS	HYD PIPING	FIRE PUMPS	
Subtotal *	WINDSHIELD FRAME	TANKS	MG SET	
HULL INTERIOR	WINDSHIELD GLASS*	HAND BILGE PUMP	DIESEL GENERATOR	
BULKHEADS	BOW RAILS* (cont'd)		WINCHES	
CABIN (cont'd)		(cont'd)	STEERING GEAR (cont'd)	Subtotal *
TESTING & TRIALS				
TYPE	LABOR/OH	MATERIALS	TOTALS	Normal Repairs will result in the following condition:
50% OVERLOAD				SUPERIOR
HANDLING				AVERAGE
REMOVE ENGINE				POOR
INSTALL ENGINE				INSPECTED BY:
TEST SLING				
SEA TRIAL				
SUB TOTAL				

Figure 583-1-1s1 Boat Inspection Report NAVSEA 9583/series (Sheet 1 of 2)

BOAT INSPECTION REPORT
 CCD 2311/1 FROM NAVSEA 9583/2 Hull No.:

REPAIR COSTS FROM PAGE ONE				
TYPE	LABOR	OVERHEAD	MATERIAL	
HULL-INT., EXT., TOPSIDE				\$
AUXILIARY MACHINERY				\$
ELECTRICAL				\$
PIPING SYSTEMS				\$
NET COSTS				
BOAT ALTS PRIORITY "A"				\$
BOAT ALTS PRIORITY "B"				\$
COSMETIC/MAINTENANCE ITEMS				\$
MAIN PROPULSION				\$
TEST AND TRIALS				\$
BOAT ALTS PRIORITY "C"				\$
INSTRUMENT AND GAUGES				\$
GROSS				
NET COSTS				
GRAND TOTAL				
REMARKS				

Figure 583-1-1s2 Boat Inspection Report NAVSEA 9583/series (Sheet 2 of 2)

S9086-TX-STM-010

583-1.4.4 TRANSFERS TO MILITARY ASSISTANCE PROGRAMS. Transfer of U.S. Navy boats to foreign governments usually begins by boat identification by PEO SHIPS PMS 325, inspection of the boat by the recipient foreign government, and then issuance of a formal Letter of Offer and Acceptance (LOA) by the U.S. Navy. A Foreign Military Sales (FMS) case is established upon signature acceptance of the LOA by the foreign government that specifies delivery dates and means of transportation. When boat repairs are necessary before delivery to a shipper for overseas transportation, PEO SHIPS PMS 325 will specify funding levels and the authorized repair list. Other public laws may be invoked (such as PL506A) after a Presidential determination to reduce inventory of active or reserve forces to expedite delivery of boats or support equipment to a recipient nation. In this case, PEO SHIPS PMS 325 will provide specific instruction regarding acceptance inspections and method of transportation. The PL506A transfers are usually done on short notice within an abbreviated time window specified in the Presidential determination. Frequently, the U.S. Navy unit providing the boats or equipment will be tasked to provide initial operating and maintenance instruction on site in the foreign nation using Mobile Training Teams (MTT). In all transfers to foreign nations, the boats and equipment provided should be in Ready-For-Issue/Combat Ready (C-1) material condition to preclude a U.S. Navy requirement to effect repairs on site in the foreign country and because of immediate operating requirements upon arrival in a foreign nation. The LOA specifies actual conditions at delivery for sale or transfer that the U.S. Navy is required to honor.

583-1.4.5 REPORTING TRANSFERS AND RECEIPTS. All receiving custodial commands shall report all boat transfers and receipts to PEO SHIPS PMS 325 within 5 days of the transaction. This is necessary to accurately maintain custodian accounts. Record correspondence is required with attention to PEO SHIPS PMS 325 and may be accomplished by formal letter, naval message, or facsimile (FAX) transmission of DD Form 1348 (Issue Release/Receipt Document) (properly completed). Reports are not to be used for recording changes in status of boat condition (that is, under repair or not onboard).

583-1.4.5.1 Changes in Custody Status. All stocking activities shall promptly report changes in custody status of boats and landing craft to PEO SHIPS PMS 325 by marking up a copy of the PEO SHIPS PMS 325 authorizing letter or message, or by forwarding a copy of DD Form 1348 as a turn-in document. The date reported shall be the exact date of the change, not the date mailed. The authority for the change in status shall be cited.

583-1.4.5.2 Issues. All issues and to whom issued shall be reported to PEO SHIPS PMS 325.

583-1.4.5.3 Receipts. All receipts and from whom received shall be reported. The submission of these receipts shall be made promptly and shall not be delayed until the submission of NAVSEA 9583/3, Boat Inspection Report, Figure [583-1-1](#).

583-1.4.5.4 Disposal. Boat disposals are the responsibility of the custodian. The custodian is responsible for requesting Disposition Instructions via letter. PEO SHIPS PMS 325 will evaluate the request, including the Boat Inspection Report and determine if disposal is to be authorized or the boat is to be turned in to stock. When disposal is authorized, after receipt of authorization by PEO SHIPS PMS 325 Boats are normally disposed of by turn-in to the nearest Defense Reutilization and Marketing Office (DRMO) by the custodian.

583-1.4.5.5 Repairs. Repairs are the responsibility of the custodian.

583-1.4.6 BOAT SURVEYS AFLOAT. When a boat is damaged such that a U.S. Navy intermediate or depot level repair activity cannot affect economical repairs, The Commanding Officer may submit a Request for Disposition Instructions with Replacement including a boat inspection report, as defined in paragraph [583-1.5](#) (Turn-In Procedures). The completed letter and report shall be forwarded to PEO SHIPS PMS 325 for authorization.

583-1-6

583-1.5 TURN-IN PROCEDURES.

583-1.5.1 PEO SHIPS PMS 325 AUTHORITY FOR TURN-IN OF BOATS. Turning in a boat for stock or disposal has specialized requirements, which are the responsibility of the custodian. General authority and reporting requirements are given in paragraph [583-1.4](#).

583-1.5.2 SURVEY REQUIREMENTS. Before turn-in, a Boat Inspection Report (BIR) must be performed. The Boat Inspection Report, NAVSEA 9583/3, Figure [583-1-1](#) will be submitted by the boat custodian to PEO SHIPS PMS 325. Based on this survey, PEO SHIPS PMS 325 will determine whether the boat is to be turned in for stock or for disposal, and will issue specific disposition instructions to the custodian activity.

583-1.5.3 TURN-IN FOR STOCK. Boats that do not qualify for disposal due to age and condition shall not be turned in for stock until they are in a Ready For Issue (RFI) condition. It is the responsibility of the custodian to ensure the boat is in RFI condition prior to turn in. Major spares, such as shafts, rudders, struts, or propellers, shall be turned in with the boat. These spares are provided with new boats because of their uniqueness to a particular production run and generally cannot be interchanged between boats built under different contracts.

583-1.5.3.1 Proper Boat Maintenance. Proper Boat Maintenance is the Responsibility of the User Command/Activity. If receipt inspection of an excess boat reveals that it was not properly maintained, PEO SHIPS PMS 325 is authorized to request, via the chain of command, that the former user command/activity identify funding to return the boat to a serviceable condition. Boats shall be maintained in accordance with the Planned Maintenance System (PMS), as defined in OPNAVINST 4790.4D.

583-1.5.4 BOAT DISPOSAL. Boats shall not be disposed of unless such disposal has been authorized by PEO SHIPS PMS 325.

583-1.5.5 PREPARATION FOR TURN-IN. Whether turning in a boat for stock or for disposal it is the responsibility of the custodian activity to ensure that a lack of preservation or presence of environmentally hazardous materials onboard does not impose an additional burden on the receiving activity.

583-1.5.5.1 Removal of Hazardous Materials. All batteries and fuel shall be removed and the bilges shall be dry and free of petroleum products before turn-in.

583-1.5.5.2 Preservation. The custodian activity shall preserve the craft IAW Section 10 before turn-in.

583-1.5.5.3 Certification. The custodian activity shall prepare a Boat "Ready for Turn-In Certification Form", submit the original to PEO SHIPS PMS 325, and provide a copy of the Certification Form to the receiving activity upon delivery of the boat. The "Boat Ready for Turn-In Certification Form" and a sample cover letter are provided, see Figure [583-1-2](#).

S9086-TX-STM-010

SAMPLE LETTER

From: Certifying Command

To: Program Executive Office (PEO) Ships PMS 325

Via: Chain of Command

Subject: Certification of Boat Ready for Turn-In

Reference: (a) Naval Ships Technical Manual Chapter 583

Enclosure: (1) BOAT READY FOR TURN-IN CERTIFICATION FORM

1. Per reference (a), enclosure (1) is submitted for your records.
2. Certifying Command Point of Contact.

Signature of Department Head or Higher Authority

Figure 583-1-2 Sample Certification of Boat Ready for Turn-In Letter with Boat Ready for Turn-In Certification Form

583-1.5.6 RECEIPT INSPECTIONS. The receiving activity will inspect boats delivered for turn in to ensure they comply with all turn-in procedures.

NOTE

The receiving activity may refuse receipt if the boat has not been properly prepared for turn-in or a signed "Boat Ready for Turn-In Certification Form" has not been provided. Additional shipping, hazardous material removal and preservation costs resulting from rejection or noncompliance with turn-in procedures of a boat for turn-in will be the responsibility of the custodian activity.

583-1.6 ALTERATIONS

583-1.6.1 CHANGES TO AUTHORIZED BOAT CONFIGURATIONS. All configuration changes shall be based on the procedures described herein. Boat configuration changes to standard U.S. Navy boats are often necessary for user boat custodians to accomplish assigned tasks in their geographic location. Alterations may affect characteristics such as speed, displacement, cargo capability, passenger capacity, or outfit to support special functions such as diving or salvage. A Boat Alteration Record (NAVSEA 4720/series) is developed and issued by PEO SHIPS PMS 325 for specific classes of boats or individual boats with special requirements. Before a boat alteration action can be initiated, an alteration authorization request (Figure 583-1-3) must be forwarded to PEO SHIPS PMS 325 via the pertinent chain of command. The request must justify the need for the change; citing safety, logistics problems, increased capabilities, reduced operating cost, and a cost benefit analysis. PEO SHIPS PMS 325 will review the alteration request and will determine if the alteration is economically and operationally justified. The cost benefit analysis shall include:

- a. Technical Feasibility Study. Evaluate the technical feasibility of the proposed change. Specifically:
 1. Validate the current configuration.
 2. Investigate alternatives.
 3. Estimate weight change.
 4. Predict the weight change's overall effect.
 5. Evaluate structural impact.
 6. Evaluate system impact.
 7. Finalize weight impact.
 8. Report results.
 9. Evaluate interface impact.
- b. Cost Benefit Analysis. Evaluate the cost feasibility of the change by performing a Cost of Ownership Analysis (COA) and completing a Justification/Cost form (NAVSEA FMP Manual refers). The COA compares the cost of the existing configuration with the replacement or new configuration. Total cost of ownership includes:
 1. Performance cost and saving (e.g., increase and decrease in fuel cost; reliability of the equipment).
 2. Maintenance cost and saving (e.g., changes to manuals, training, provisioning, Planned Maintenance System (PMS), etc.).
 3. Cost of installation of the new configuration.
 4. One time cost of the new configuration (e.g., COA, BOATALT, prototyping, testing and evaluating).
 5. Intangible costs and benefits (performance, safety, maintainability, etc.).
 6. Evaluation of the remaining life of the craft proposed for the installation (survey via correspondence and on-site; review maintenance and performance records).
 7. Calculation of the Total Cost of Ownership of the new configuration versus the existing configuration, based on the remaining life of the craft.

If justified by the cost benefit analysis, PEO SHIPS PMS 325 will prioritize, fund, and develop the proposed alteration. If available program funding is insufficient, the requesting activity may assume the cost of the development of the alteration. Unfunded, approved alterations will be deferred and considered in the next POM cycle. Alteration authority may be issued by Boat Alteration (BOATALT), Alteration-Equivalent-To-Repair (AER), or PEO SHIPS PMS 325 authorizing letter, depending upon the magnitude of the proposed configuration change. Alteration of a boat, to any extent not shown on the approved NAVSEA drawing, is not permitted without prior

S9086-TX-STM-010

authorization from PEO SHIPS PMS 325 regardless of the funding source. In certain circumstances, minor configuration changes may be authorized by type commanders as Type Commander Issued Alterations (TIA). Alterations of any type will not be approved which would result in a net adverse stability condition, increase the weight of a ship's boat causing the Safe Working Load of the assigned davit to be exceeded, or result in design mission capability degradation. Changes in design mission require prior approval of the Chief of Naval Operations in most circumstances. An example of this would be a request to weld a Landing Craft bow ramp closed where an existing ship-to-shore cargo or troop lift requirement may exist.

DATE: _____

BOAT ALTERATION REQUEST FORM

BOAT HULL NO.: _____ **PRIORITY CLASS:** **A** **B** **C**

TITLE OF ALTERATION RECOMMENDATION: _____

REASON FOR REQUEST:

<input type="checkbox"/> SAFETY <input type="checkbox"/> IMPROVED CAPABILITY <input type="checkbox"/> REDUCED MAINTENANCE <input type="checkbox"/> INADEQUATE DESIGN <input type="checkbox"/> ENVIRONMENTAL	<input type="checkbox"/> MAINTENANCE PROBLEM <input type="checkbox"/> HUMAN FACTORS <input type="checkbox"/> EQUIPMENT UNAVAILABILITY <input type="checkbox"/> OTHER (EXPLAIN)
---	---

AREA OF BOAT AFFECTED:

<input type="checkbox"/> HULL <input type="checkbox"/> MECHANICAL	<input type="checkbox"/> ELECTRICAL <input type="checkbox"/> ELECTRONIC
--	--

SKETCHES ILLUSTRATING PROPOSED CHANGE:

YES (INCLUDE WITH FORM) NO

VENDOR INFORMATION: (IF APPLICABLE)

PART NUMBER	_____
CATALOG NUMBER	_____
VENDOR DOCUMENTATION	_____

BRIEF DESCRIPTION OF PROPOSED ALTERATION: _____

POINT OF CONTACT:

NAME	POSITION/GRADE/RANK/RATE	TELEPHONE
------	--------------------------	-----------

Figure 583-1-3 Boat Alteration Request Form

583-1.6.2 BOAT ALTERATION (BOATALT) RECORDS. The BOATALT record describes in detail the configuration change that is authorized. Engineering sketches are provided with alteration material lists (AML), quality assurance, and integrated logistics support requirements. Maintenance, special tools and test equipment, billet and supporting technical documentation changes are identified. Boat custodians are responsible for requesting PMS documentation changes and reporting completion of alteration work on standard OPNAV 4790/2K CSMP forms, as well as reporting configuration changes to the responsible Configuration Data Manager (CDM) via OPNAV 4790/CK, and by letter to the boat In-Service Engineering Agent (ISEA) designated by PEO SHIPS

S9086-TX-STM-010

PMS 325. The BOATALT's for U.S. Navy ships' boats and for boats assigned to shore stations differ in application from CRAFTALT's, which are developed for the Naval Special Warfare Command craft. CRAFTALT authority for accomplishment may be authorized by PEO SHIPS PMS 325 for standard boats, such as the 7 meter RIB or the 11 meter LCP(L), on a case-by-case basis, upon boat custodian request, with endorsements by the support commander. BOATALT application by registry number or boat type mark (such as all 13mPEs) is usually annotated on the first BOATALT page.

583-1.6.2.1 Numbering. The BOATALT identification consists of the boat length, abbreviated two-letter boat type, the alteration four-digit serial number, and an accomplishment priority letter (Example: 11RX/0102 A). A revision to a basic BOATALT carries a letter sequence designation (Example: Rev D for the fourth revision). If an alteration has application to several different types of boats, then it will carry a GENERAL designation with the serial number, an accomplishment priority letter, and the sequential revision letter designation.

583-1.6.2.2 Boat/Craft Alteration (ALT). The BOAT or CRAFT ALT established class indicates the relative importance for accomplishment. The priorities are defined as follows:

- a. Class A: MANDATORY ACCOMPLISHMENT. Usually for safety reasons or compliance with effective public laws, regulations or court decisions.
- b. Class B: ESSENTIAL FOR ACCOMPLISHMENT. Provides a needed improvement in boat capabilities.
- c. Class C: DESIRABLE ACCOMPLISHMENT. A useful improvement in boat capabilities. Example: BOATALT RECORD 11RX/0002A is the second alteration approved for the 11M RIB boat, which has first priority for accomplishment because of safety or mission essentiality.

583-1.6.3 ACCOMPLISHMENT. A BOATALT with a low sequence number should be checked for application. Boat types of the same class with a hull number year indicator later than the approval date of the BOATALT should be examined for application to the construction contract date and the type and mark of the boat. An example is BOATALT 33PE/02C, which was approved in 1972 (or earlier) and would not apply to 33PE8712, which was in the 1987 acquisition contract. Another example is BOATALT 26MW/10C, which was approved in 1964 for the MK9 26MW but has no application to MK10 and subsequent 26MW. The Historical Boat Alteration Listing is published in June of each year by the Planning Yard and given wide distribution to boat custodians, repair and overhaul activities, and operational and administrative commanders. This annual listing summarizes effective boat alterations by boat type and annotates BOATALT cancellations. This cancellation list should be examined for application to boat alteration records. Cancelled BOATALT's need not be retained for reference purposes in ship or shore station files. Accomplishment of all BOATALTs shall be recorded on the boat's BOATALT label plate.

583-1.6.3.1 Stock Boats. Class A and B BOATALT's will normally be accomplished during repair of a boat to issuable status or before issue. Priority C BOATALT's will be accomplished only if deemed necessary and if funds are available.

583-1.6.3.2 Active Boats. Class A BOATALTs should be accomplished at the next scheduled Intermediate Maintenance Activity (IMA) repair availability. Ship's force or the supporting organization level maintenance organization should complete an A priority BOATALT as soon as possible after receipt of materials. A Class B BOATALT should be accomplished within one year of the approval date on the BOATALT. The elective C class BOATALT may be accomplished at the earliest convenience of the boat custodial activity. U.S. Navy Operation and Maintenance funds (O&R)) administered through the major fleet commanders to subordinate activities are

the usual source for BOATALT material acquisition and commercial contractor installation services, if required. BOATALT's installation may be accomplished by organization or intermediate level maintenance activities during assigned repair availabilities.

583-1.6.3.2.1 Repair Activities. Repair activities should maintain active files of approved BOATALTs and AER's by boat type. The files should be updated annually within thirty days of receipt of the Historical Boat Alteration Listing described in paragraph 583-1.6.4 and canceled BOATALT's deleted from the active files. BOATALT and AER's not on file should be requested, using the replacement directions provided in the Historical Boat Alteration Listing. The BOATALT completion label plate should be examined for accuracy during assigned boat repair availabilities or overhauls and compared to the BOATALT and AER file for the type boat under repair. A review of the technical specifications for each applicable BOATALT, coupled with a boat inspection, will identify which BOATALT and AER's were not completed or only partially completed for the specific hull under repair. The boat custodial command should be advised of discrepancies for entry into his CSMP (Current Ship's Maintenance Project) for subsequent repair availability planning purposes.

583-1.6.4 BOATALT ISSUANCE AND CANCELLATION. The BOATALT and AER file is reviewed annually by PEO SHIPS PMS 325 and the Planning Yard to identify candidates for cancellation. Periodic cancellation summaries are issued to a wide distribution list during the year, using the first page of the BOATALT form. The annual Historical Boat Alteration Listing recaps cancellation listings for reference. BOATALT's and AER's are approved by PEO SHIPS PMS 325 after engineering development by the ISEA or the Planning Yard. Distribution is subsequently made by the Planning Yard to boat custodial commands, repair activities, and operational and administrative commanders. A list of BOATALT's may be found at www.boats.dt.navy.mil.

583-1.6.5 AUTHORIZATION. Because most alterations required in boats can be readily accomplished with a small expenditure of funds, most BOATALT's issued are to be accomplished either by forces afloat or by an Intermediate Maintenance Activity (IMA). Occasionally, BOATALT's are issued that are of a complex enough nature that they will have to be accomplished at a depot level repair activity.

583-1.6.6 FUNDING. BOATALT and AER accomplishment is funded from OPNAV directed Operation and Maintenance, Navy (O&M) accounts managed by Support Commanders. PEO SHIPS PMS 325 receives Service Craft Modernization Program (SCMP) funds to be used to accomplish selected SHIPALT's on active service craft. The BOATALT's in this category will normally be limited to those that increase the military capability of the craft (that is, adding a radar, radio, or gun) or those that are the result of a directed program, such as pollution abatement. Funding of such alterations will be dependent on their being programmed in the SCMP by the CNO.

583-1.6.6.1 Custodian or Command Support Activity Funds. When a support commander authorizes accomplishment of a PEO SHIPS PMS 325 technically approved BOATALT, funding is provided for IMA material ordering and procurement of technical services. In some instances, BOATALT materials are purchased using local operating (OPTAR) funds for IMA or ship's force installation. Complex BOATALT's may be authorized for accomplishment by commercial repair enterprises holding Master Ship Repair Agreements (MSRA) or bid out to local contractors.

583-1.6.6.2 PEO SHIPS PMS 325 Boat Rehabilitation Funds. Boats returned to stock are refurbished to RFI condition using available rehabilitation funds provided to PEO SHIPS PMS 325 by the OPNAV sponsors. During REHAB, approved priority A and B BOATALT's for each boat type, are usually accomplished during industrial repair availabilities. Priority C BOATALT's would only be accomplished on stock boats under unusual circumstances because of funding limitations.

S9086-TX-STM-010

583-1.6.7 EXPENDITURE OF FUNDS FOR UNAUTHORIZED ALTERATIONS. Unauthorized alterations, regardless of funding source, are strictly prohibited and could result in formal administrative review procedures, particularly when PEO SHIPS PMS 325 Boat Rehabilitation funds are required to restore the boat to its original configuration.

583-1.6.8 DISTRIBUTION. The BOATALT's will be distributed under cover letter by the Planning Yard after PEO SHIPS PMS 325 signature approval. An approved distribution list is provided with the boat alteration. Distribution is limited to boat custodians affected by the configuration change, boat repair activities, support commanders, and OPNAV sponsor.

583-1.6.8.1 Distribution Requests. Addition or deletion change requests for the distribution list should be directed to the planning yard for boats:

Naval Surface Warfare Center Carderock Division, Detachment Norfolk

2600 Tarawa Court Suite 303

Norfolk Virginia 23521-3239

Or access website www.boats.dt.navy.mil

583-1.6.9 COMPLETION RECORD. Upon completion of an authorized BOATALT, a 316L CRES plate shall be installed or updated with permanent lettering by the installing activity including completion information as depicted in Figure [583-1-4](#). Boat custodians shall comply with applicable OPNAVINST 4790.D reporting instructions, using OPNAV 4790/CK forms for recording BOATALT and AER completions in the Weapons System File. Accomplishment of BOATALT or AER installation shall also be reported by letter to the PEO SHIPS PMS 325 designated ISEA. U.S. Navy boats are not included in the Fleet Modernization Program (FMP) at this time for alteration planning and reporting purposes. Boat custodians are required to weigh assigned boats upon completion of weight impacting alterations IAW paragraph [583-2.1.2](#). Scale weighing at time of receipt is advisable to establish a base line reference for future weight growth. Boat weighing by various boat construction yards has been noted to be in error by 15 percent or more because of faulty scales or weight calculation errors by the accepting contract activity.

○	BOATALTS ACCOMPLISHED	○
<i>BOATALT 27HS/0002A</i> ← EXAMPLE		
○	DO NOT DEFACE OR REMOVE	○

BOATALT LABEL PLATE

**MATERIAL: 3/32" MINIMUM 316L CRES SHEET –
ABOUT 6" WIDE BY 3 ½" HIGH –
WITH ¼" ENGRAVED BLACK-FILLED LETTERS.
BOATALT INFORMATION MAY BE STAMPED.**

Figure 583-1-4 Boat Alteration Label Plate

583-1.6.10 REQUESTS FOR BOATALT ACCOMPLISHMENT BY BOAT CUSTODIANS. Boat custodians, both afloat and ashore, scheduling an applicable Boat Alteration Record for accomplishment should obtain support commander approval when funding does not derive from local unit fund operating or special project funds.

583-1.6.11 CONVERSIONS. When authorization is requested to change the standard U.S. Navy design configuration for a specialized function, such as work boat conversion to support diver operations, technical authorization is obtained from PEO SHIPS PMS 325. A U.S. Navy field activity with boat design expertise will be tasked to develop a Boat Alteration Record for technical approval by PEO SHIPS PMS 325. During engineering development, special equipment installation requirements are reviewed for impact on boat weight and stability, and a standard installation method is established which identifies installed equipment removal and special tool requirements, provides detailed engineering drawings or sketches, and describes installation techniques, test methodology and standards, lists concurrent boat alterations to be accomplished, provides a material list with MILSPEC or MIL STD identification, and summarizes logistics support and technical documentation requirements. After signature approval by PEO SHIPS PMS 325, the authorizing Boat Alteration Record is distributed by the Planning Yard to various boat custodians, repair activities, and administrative commanders for conversion planning and funding.

583-1.6.11.1 Conversion Without BOATALT. In those cases where a partial or full conversion has been accomplished to a standard U.S. Navy boat design in the absence of an authorizing BOATALT Record, PEO SHIPS PMS 325 will document the technical changes to the boat, analyze the impact on weight and stability, and direct corrective action where the installation varies from U.S. Navy technical standards. A technically authorizing

S9086-TX-STM-010

BOATALT will be promulgated for the information of repair activities, support commanders, and boat custodians to apprise them of current special function boat conversion opportunities and disseminate the standard installation method and material lists.

583-1.7 INSPECTION.

583-1.7.1 NEW BOATS. Most new boats are delivered to a U.S. Navy Inventory Control Point (ICP) pending assignment to new construction ships, assignment to meet emergent requirements or as the replacement for existing boats that qualify for replacement. An inspection is accomplished by PEO SHIPS PMS 325 upon arrival at the ICP to ensure compliance with contract requirements and identify any shipping damage which may have occurred to the boat. In some cases where new construction boat delivery schedules are not in consonance with new construction ship delivery requirements, boats may be shipped directly from the building boat yard to the cognizant ship construction activity in care of the resident U.S. government inspection activity or the construction yard as government furnished equipment.

583-1.7.1.1 Warranty Period. Each new delivery carries a warranty from the day of acceptance at the boat builder by a U.S. government representative. The contractor is liable for the correction of warranty items within the warranty period as reported by the receiving boat custodian to PEO SHIPS PMS 325. It is important to note the actual boat acceptance date because the new boat may have been placed in storage pending delivery to the ship. Some boats are reserved in storage for new construction ships in a long-term ship class construction program. The boats may or not be in covered storage for periods of several years before delivery. Before shipment, these boats receive a special inspection to identify deficiencies in outfit and for damage incurred in storage. Inspection deficiencies including the effects of weathering are usually corrected at the receiving point. The 6-month contractual warranty coverage period, in some instances, will have expired before boat delivery and the start of boat operations. Defects in workmanship or initial parts failure should still be referred to PEO SHIPS PMS 325 for resolution. PEO SHIPS PMS 325 and the cognizant support commanders have corrective action resources upon which to effect corrective action. It is imperative that the boat custodian conduct a receipt inspection using the Boat Check List (Table [583-1-5](#)) to identify deficiencies to PEO SHIPS PMS 325 and the support commander.

583-1.7.1.2 Boat Receipt Inspection. All custodians of new boats are requested to perform an immediate inspection upon receipt using the Boat Check List (Table [583-1-5](#)). Notify PEO SHIP PMS 325 if the boat is preliminarily acceptable. Boat hoisting equipment shall be verified to ensure the Hoisting Label Plate specifies the weight of boat to be hoisted. If the boat weight exceeds the hoisting weight, notify PEO SHIPS PMS 325 immediately.

583-1.7.1.3 Unsatisfactory Inspection. If the boat is not considered to be preliminarily acceptable, recipients are requested to:

- a. Notify PEO SHIPS PMS 325 of any shipment damage observable, furnishing photographs if practical.
- b. Notify PMS 325 of any boats received that are unsatisfactory, defective, or deficient due to improper manufacturing or equipment installation. It is recommended that, in addition to the initial inspection, all new boats be inspected at intervals during the warranty period as to allow for proper detection and timely reporting of defects that might occur during the guarantee period.

583-1.7.1.4 Acceptance Notification. Notification of preliminary acceptance shall be by letter and in no case shall the initial inspection be delayed for a period in excess of 5 days from the date of receipt of the boat. All boats receive extensive tests and trials under the terms of the contract. Accomplishment of additional tests and trials on new boats received is not mandatory but may be conducted if deemed advisable.

583-1.7.1.5 Estimating Costs. Only those representatives designated by PEO SHIPS PMS 325 having knowledge of fleet requirements, standards of workmanship required in naval craft, and of the details cited in applicable plans and specifications for various materials and equipment incorporated, shall inspect boats for nonconforming deficiencies or for estimating repair costs. See paragraph [583-1.10.2](#).

583-1.7.2 BOATS IN STORAGE. Initial inspection of boats received in stock is performed by PEO SHIPS PMS 325.

Table 583-1-5 Boat Check List

BOAT TYPE:				HULL NO.:	
SHIPPING ACTIVITY		RECEIVING ACTIVITY		DESCRIPTION	REMARKS
SAT	UNSAT	SAT	UNSAT	HULL EXTERIOR	
				Bow/Stem	
				Port Gunwale	
				Port Side	
				Port Rub rail	
				Port Chine	
				Port Bottom	
				Stbd Gunwale	
				Stbd Side	
				Stbd Rub rail	
				Stbd Chine	
				Stbd Bottom	
				Transom	
				Transom Corners	
				Transom Extension	
				Propeller	
				Water Jet	
				Rudder	
				Shaft	
				Strut	
				Strut Brg	
				Stuffing Box	
				Anodes (zinc)	
				Ramp	
				Ramp Hinge	
				Ramp Gasket	
				Paint	
SAT	UNSAT	SAT	UNSAT	HULL INTERIOR	
				Bulkheads	
				Battery Boxes	
				Cabin	

S9086-TX-STM-010

Table 583-1-5 Boat Check List - Continued

BOAT TYPE:				HULL NO.:	
SHIPPING ACTIVITY		RECEIVING ACTIVITY		DESCRIPTION	REMARKS
				Cargo Plat	
				Coxswain Plat	
				Cushions	
				Door	
				Hatches	
				Hand/Grab Rails	
				Lifting Pads	
				Lockers	
				Manholes	
				Seats	
				Swim Platform	
				Voids	
SAT	UNSAT	SAT	UNSAT	HULL TOPSIDE	
				Cabin Top	
				Cabin Sides	
				Canopy	
				Chocks	
				Cleats	
				Coamings	
				Decks	
				Deck Coverings	
				Windows/Ports	
				Window/Shield Frame	
				Window/Shield Glass	
				Wipers/Wiper Motor	
				Bow Rails	
				Handrails	
				Lifelines	
				Taffrails	
				Toe Rails	
				Pilothouse	
				Ammo Boxes	
				Access Panels/Doors/Hatches	
				Paint	
				Tow Posts	
				Strobe/Loudspeaker/Hailer Mounts	
				Radar Mast	
				Antenna Mounts	
				Gun Mounts	
SAT	UNSAT	SAT	UNSAT	MAIN PROPULSION	
				Engine	
				Reverse	
				Decks	

Table 583-1-5 Boat Check List - Continued

BOAT TYPE:				HULL NO.:	
SHIPPING ACTIVITY		RECEIVING ACTIVITY		DESCRIPTION	REMARKS
				V-Drive	
				Outboard	
				Outdrive	
				Transmission	
				Water Jet	
				Starter	
				Alternator	
				Pump FW	
				Pump SW	
				Heat Exchanger	
				Raw with strainer	
SAT	UNSAT	SAT	UNSAT	PIPING SYSTEM	
				Bilge Pipe	
				Bilge Valve	
				BWOD	
				FW Pipe	
				FW Valves	
				SW Pipe	
				SW Valves	
				LO Pipe	
				FO Pipe	
				FO Valves	
				FLOCS	
				Exhaust System	
				Mufflers	
				Keel Cooler	
				Strainers	
				Filter LO	
				Filter FO	
				Hoses	
				Seacocks	
				Accumulators	
				Hyd Pipes/Hoses	
				Hyd Reservoir	
				Tanks	
SAT	UNSAT	SAT	UNSAT	ELECTRICAL SYSTEM	
				Wiring	
				Distribution Panels	
				Lights Navigation	
				Lights Int	
				Battery Cables	
				Battery Charging System	
				Horn	
				Spot Lights	

S9086-TX-STM-010

Table 583-1-5 Boat Check List - Continued

BOAT TYPE:				HULL NO.:	
SHIPPING ACTIVITY		RECEIVING ACTIVITY		DESCRIPTION	REMARKS
				DC Converter/Inverter	
				Deck/Work Lights	
SAT	UNSAT	SAT	UNSAT	NAVIGATION SYTEMS	
				Radio/Antenna	
				Radar/Mast	
				Global Positioning System (GPS)/Mount	
				Compass	
SAT	UNSAT	SAT	UNSAT	INSTRUMENTS/GAUGES	
				Ammeters	
				Oil Pressure, Engine	
				Oil Pressure, Reservoir	
				Oil Temperature	
				Water Temperature	
				Hydraulic Pressure	
				Hydraulic Temperature	
				Tachometer	
				Fuel Gauges	
				Tilt/Trim Switch	
				Hourmeter	
SAT	UNSAT	SAT	UNSAT	AUXILARY EQUIPMENT	
				Air Compressor	
				Windlass	
				Capstan	
				Cranes	
				Fire Pumps	
				Fire Extinguishing System	
				MG Set	
				Diesel Generator	
				Winches	
				Steering Gear	
				Heating System	
				Air Conditioning System	
				Bilge Pumps	
				Spares	
Additional Remarks					

583-1.7.2.1 Pre-Issue Inspection. Before issuing a boat from storage, an inspection of the boat shall be made by an individual experienced in boat repair and fleet requirements. If deficiencies exist, or required alterations have not been accomplished, these deficiencies shall be reported to PEO SHIPS PMS 325 for further instructions. New boats, that were trialed before shipment and then preserved, need not be trialed but may be issued as is.

Depreservation and starting instructions shall be available to guide the recipient of the boat. If the boat has been stored for a year or more and the condition is not known, a trial run shall be made unless otherwise directed by PEO SHIPS PMS 325.

583-1.7.2.2 Post Issue Rejection. Rejection of a boat after issue and shipment to the ship or shore station should be carefully considered because of time delays that can occur in identifying and shipping another suitable boat. If an RFI boat is received and discrepancies are found and indicated on the Boat Check List, Table 583-1-5, forward a copy of Table 583-1-5 (correctly annotated) along with the receiving report to PEO SHIPS PMS 325. However, the following factors shall not be cause for rejection by ships and shore stations:

- a. Incomplete inventory of spares that are shipped separately. Notify PEO SHIPS PMS 325 immediately in the event of an imminent deployment where full Boat Allowance List (BAL) and required Coordinated Shipboard Allowance List (COSAL) load lists are necessary as deployment spares.
- b. Slight variations in hull painting schemes caused by fading or touch-ups.
- c. Waterline saltwater discoloration caused by initial operations testing at the building yard. Hull bottoms are usually scrubbed and hull dings touched up at the building yard before shipment.
- d. Slight rusting on metallic parts, which can be readily cleaned and preserved by ship's force.
- e. Incomplete outfitting discrepancies, which should be immediately described to PEO SHIPS PMS 325 for correction.
- f. Cosmetic blemishes correctable by buffing or light sanding and road hazard dings occurring during surface delivery.

583-1.7.2.3 Non-RFI Issue. Because of budgeting constraints and scheduling requirements, a non-RFI boat may be offered by PEO SHIPS PMS 325 to boat custodians requesting turn-in and replacement of damaged boats or boats which are not economical to repair. A newer boat of later design but with prior fleet use may be offered on an as-is basis. Usually an inspection opportunity is offered to the receiving boat custodian before acceptance. The following factors are not cause for rejecting a non-RFI boat when it is received alongside:

- a. Lack of complete hull painting.
- b. Slight cracks or dished-in hull areas not affecting hull integrity or strength.
- c. Oxidized metallic areas that can be preserved by ship's force.
- d. Absence of original outfit items and repair parts.
- e. Lack of technical documentation such as Boat Information Book, Technical Manuals, and operating records. Technical documentation can be obtained from publications stocking activities.
- f. Deformation of hull parts such as the hull beading or bilge keels. It is recommended that non-RFI hulls accepted by boat custodians receive immediate repair availability at an IMA to restore the boat to an acceptable condition of readiness and appearance.

583-1.8 PREPARATION FOR SHIPMENT

583-1.8.1 SHIPMENT DESTINATION. Unless otherwise specified, boats shipped from stock or for transfer shall be prepared for delivery as follows:

S9086-TX-STM-010

- a. Local destination. Boats issued locally shall be delivered in the as-is or as stored condition. All items not installed should be secured against movement. Unprotected equipment openings shall be sealed to prevent entrance of dirt or water. Attach depreservation instructions to the equipment involved. Refer to paragraphs [583-9.4.3](#) through [583-9.4.3.3](#) for engine starting instructions.
- b. Destination not local. Boats shipped beyond the local area shall be preserved as required by paragraphs [583-9.2](#) through [583-9.2.4](#).

583-1.9 SHIPMENT OF BOATS

583-1.9.1 PEO SHIPS PMS 325 SHIPMENT ORDER. Shipment of boats will normally be accomplished by shipment order prepared by PEO SHIPS PMS 325.

583-1.9.2 SHIPMENT PRECAUTIONS. The following precautions shall be observed when loading boats for shipment:

- a. Cradle cross members (chocks) shall be rigidly braced to prevent collapse.
- b. Towing padeyes or other fittings installed on the boat shall not be used as tie down points.
- c. Strongbacks shall not be tensioned to such a degree that the chocks deform the hull.
- d. Bumpers shall be installed where the ends or sides of the boat may be damaged during shipment.
- e. Snubbing of boats so that the forces received during transit are transmitted to the stem or transom end is not permitted.
- f. The weight of the boat shall be borne by the keel supports, not the side bunks. Side bunks for plastic and steel boats should be at least 10-inches wide and should be located opposite a frame or bulkhead, or where weights are concentrated, such as the engines. In case the boat does not have structural type keel, full strength supports shall be installed opposite the interior longitudinal bilge stringers.
- g. Bilge plugs shall be removed and attached to the steering wheel at the coxswain's station.
- h. Ensure that the engine cooling and piping systems are drained or protected from freezing.
- i. Batteries shall be disconnected.
- j. Fuel tanks shall be drained.
- k. Consideration should be given to temporary storm cover over windows.
- l. Secure all mast and antennas.
- m. Secure all doors and hatches against leaks and damage.

583-1.10 REPLACEMENT OF BOATS IN SERVICE

583-1.10.1 SERVICE LIFE FOR NAVY BOATS AND CRAFT. Service Life for Navy Boats and Craft (for budget/replacement purposes) is usually defined as 20 years for Navy Standard fiberglass boats. COMMERCIAL-OFF-THE-SHELF (COTS) boats have an expected service life of 10-years when routinely

operated at less than 1000 hours per year, and 7 years for those which have 24/7 operational requirements. Examples are the Antiterrorism/Force Protection with an increased operational tempo will have a reduced service life. Requests for replacement should to be submitted through the appropriate chain of command with a completed copy of the Boat Inspection Report.

583-1.10.2 REPAIR COST ESTIMATES. Estimates of repair costs to boats shall be made by a designated representative of PMS 325. A boat needing repairs beyond the capability of ship's force or station personnel shall be made the subject of a work request to a repair activity in the availability period. The size, type of boat and its U.S. Navy hull registry number shall be given.

583-1.10.3 TYPE OR AREA COMMANDER'S FUNDS FOR REPAIR. The repair of boats shall be funded with Type or Area (Support) Commander's funds and shall be accomplished without reference to NAVSEA, unless deemed irreparable or beyond the expected service life (in general, 20 years for fiberglass boats and 25 years for metal boats) of the boat.

583-1.10.4 REPAIRABILITY OF BOATS. No in-service standard Navy designed boat will be considered for replacement until it has reached the expected service life or has encountered a major catastrophe that renders it unusable or unserviceable. If the repair activity, Type, or Area Commander considers the cost of repair to be excessive, the responsible activity shall complete and submit NAVSEA 9583/3 (Figure 583-1-1) and forward to PEO SHIPS PMS 325. If PEO SHIPS PMS 325 decides the boat is repairable, repairs shall be made and funded with Type or Area Commander's funds. The feasibility of repairing or the replacing the boat will be determined solely by NAVSEA.

583-1.10.5 ENGINE STATUS. The NAVSEA 9583/3 (Figure 583-1-1) shall include a statement as to whether or not the engine is serviceable or warrants repair.

583-1.10.6 PREPARATION OF CRAFT AND BOATS TURNED IN FOR REPAIR OR STOCK. Whenever a boat or craft is turned in for repair or for stock, the fuel tanks shall be drained and the bilges cleaned. Ensure that the engine cooling system is drained or protected from freezing and that necessary preservation is accomplished. There shall be no cannibalization of the boat or propulsion system. The technical manuals, spare propellers, and shafts shall be turned in with the craft.

583-1.11 STOCK CLASSIFICATION, LEVELS, AND DISTRIBUTION

583-1.11.1 STOCK CLASSIFICATION. Stock boats are divided into three categories. As noted below, stock boats shall be placed in one of these categories only because of inspection by qualified personnel who complete NAVSEA 9583/3 (Figure 583-1-1) according to paragraph 583-1.12.6.1.

583-1.11.1.1 Issuable (Ready for Issue) (A Condition). Any boat that can be made operational and seaworthy with a minimum amount of productive labor time and without expenditure of funds for major alterations or repair other than depreservation, varnishing, painting, minor caulking, testing, and electrical or mechanical adjustments. These items shall be accomplished when the boat is issued. The presence of miscellaneous outfit items, such as life jackets, boat hooks, life ring, mooring lines, etc., which are part of the ship's Allowance Equipage List (AEL) for the boat, is not required for a boat to be considered issuable.

S9086-TX-STM-010

583-1.11.1.2 Repairable (F Condition). Any boat not in issuable condition, for which a determination has been made that it is economically feasible to repair the boat to an issuable condition, see paragraph [583-1.10.3](#).

583-1.11.1.3 Beyond Economical Repair (X Condition). Any boat considered too costly (see paragraph [583-1.10.4](#) for definition) to place in issuable condition.

583-1.11.2 STOCK LEVELS. The total number of boats to be carried in inventory at ICPs will be determined by PEO SHIPS PMS 325.

583-1.11.2.1 Minimum Stock Levels. Minimum stock levels of issue boats are no longer being established. Stock boats will be repaired to meet near term requirements as directed by PEO SHIPS PMS 325.

583-1.11.2.2 Uneconomical Repair to Stock Boats. Stock boats which are considered to be uneconomical to repair, based upon the latest Inspection Report may be held in stock because of a critical shortage or because no substitute boat can be utilized. When it is determined by PEO SHIPS PMS 325 that the special status of the boat no longer exists, disposal will be directed by PEO SHIPS PMS 325.

583-1.11.2.3 Stock Boat Repairs. Repairs to stock boats shall not be accomplished unless specifically authorized by PEO SHIPS PMS 325. Preference will be given at all times to those boat types having the highest rate of issue and the largest requirement of mobilization. Selection of boats for repair to issuable condition shall be made from existing inventory.

583-1.11.3 STOCK DISTRIBUTION. Selection of boats for issue shall be on the first-in first-out basis whenever practical and shall be made from existing stocks of issuable boats.

583-1.12 PRESERVATION, MAINTENANCE, AND REPAIR

583-1.12.1 PRESERVATION AND MAINTENANCE. Initial preservation is authorized on all boats determined to be economically repairable without reference to PEO SHIPS PMS 325. Cyclic preservation and routine maintenance of boats in storage is necessary to maintain stock boats in an issuable or repairable condition. This work is authorized without reference to PEO SHIPS PMS 325 (refer to paragraphs [583-9.1.1](#) through [583-9.2.4](#)).

583-1.12.2 REPAIR. Repairs to boats in storage will be made according to paragraphs [583-1.10.4](#) through [583-1.10.6](#).

583-1.12.3 COST. The cost of work stated in paragraph [583-1.10](#) will be charged to funds provided by PEO SHIPS PMS 325 for the repair of boats in storage. The cost of work listed in paragraph [583-1.10.2](#) should be charged to funds provided by the Naval Supply Systems Command, except at activities whose supply operations are funded by PEO SHIPS PMS 325. These costs are to be charged to the funds granted for supply operations. If funds are not available, PEO SHIPS PMS 325 should be advised. The procedures for estimating repair costs to stock boats are outlined in the following paragraphs:

583-1.12.4 ESTIMATING COSTS. NAVSEA 9583/3 (refer to Figure [583-1-1](#)) shall be used by boat inspectors when preparing repair cost estimates and shall be completed promptly for:

- a. All boats and landing craft in service which have been inspected and for which the user will require repairs or need to request replacement. Send original copy to user and a copy to PEO SHIPS PMS 325.
- b. All boats and landing craft received in stock from deactivating ships or those craft turned in as excess to allowances. Send original copy to PEO SHIPS PMS 325.
- c. All boats and landing craft in stock when deterioration or unauthorized stripping has significantly changed the condition and former estimate of repairs. Send original copy to PEO SHIPS PMS 325.
- d. All boats and landing craft in stock when local labor rates have increased significantly. A yearly review should be made of previously submitted inspection reports and marked up to show the current estimated costs. Send a copy to PEO SHIPS PMS 325.

583-1.12.5 BOATS ASSIGNED TO SHIPS OR ACTIVITIES. Should the NAVSEA 9583/3 indicate a high repair cost or if replacement has been recommended, the user shall enclose the original copy in a letter to PEO SHIPS PMS 325 requesting a review and determination on a possible replacement. The user shall include the possible date that a replacement is required and any changes in ship's location.

583-1.12.6 BOAT INSPECTION REPORT. Page 1 of NAVSEA 9583/3 is divided into nine sections: hull exterior, interior, and topside, piping systems, main propulsion, auxiliary equipment, electrical systems, instruments and gauges, and testing and trials. Page 2 is for notes describing problem areas and for the Boat Inspector to determine final estimated net and gross repair costs.

583-1.12.6.1 Inspection Report Use. During the inspection, the inspector is to indicate in the appropriate left hand block, either an X for replacement, R for repair, I for items requiring testing, a "check" for items considered to be satisfactory, or NA when not applicable. At the same time, the percentage of each item, (for example, 20 percent of bottom) or number of square feet (for example, 15 square feet of side plating) and the estimated man-hours to correct, can be noted in the space at the right of each item. The subtotal line can indicate material and labor costs for use in developing final-estimated costs. The items marked with an asterisk on the report are either cosmetic in nature and not essential to the boat's operation or are normal maintenance items that should be maintained, repaired, or replaced by ships' force during normal upkeep. These costs are not to be included in the net cost estimate that is used by PEO SHIPS PMS 325 to determine if an in-service boat should be repaired or replaced. These costs will be used however, to determine disposition of PEO SHIPS PMS 325 stock boats.

583-1.12.6.2 Routine Maintenance. Accomplish routine maintenance of all onboard or installed boat equipment including items of outfit.

583-1.12.6.3 Inspection Report Use by Fleet Personnel. NAVSEA 9583/3 may be used by fleet personnel for local use in determining the condition of assigned boats for planning purposes when budgeting or requesting repair funds, or to assist in work loading at Intermediate Maintenance Activities and tenders.

583-1.12.6.4 Net Cost. When preparing repair cost estimates for boats, the following items shall be used as a basis for arriving at the net cost entered on NAVSEA 9583/3:

- a. Include the cost of repairing, renewing, testing, and refinishing all defective portions of the hull structure and hull portable parts. For this cost element, boat inspectors should separate, except for accident damage losses, costs of cosmetic and normal maintenance type items.

S9086-TX-STM-010

- b. Include the cost of renewing, repairing, and testing of all defective electrical wiring, fixtures, and electrical components not associated with the engine or items of outfit.
- c. Include the cost of renewing, repairing, and testing of all defective machinery not associated with the engine, engine components, or items of outfit.
- d. Include the cost of performing all authorized priority A and B alterations except those associated with the engine, engine component, and items of outfit.
- e. Exclude the cost of conducting water trials and the 50 percent overload test. Add to gross cost.
- f. Exclude the cost of renewing, repairing, altering, and testing of all items of outfit.
- g. Exclude the cost of altering, repairing, testing, and depreserving the engine(s) or engine components. Add to gross cost.
- h. Exclude the cost of removing or installing the engine(s) or engine components. Add to gross cost.
- i. Exclude the cost of moving the boat.
- j. Exclude the cost of chrome plating all hardware if boat is a barge or a gig. Add to gross cost.
- k. Exclude costs of class C BOATALT's.

583-1.12.6.5 Local Repair Authorization. The repair of boats assigned to ships and shore stations may be accomplished without reference to PEO SHIPS PMS 325, unless the cost of repair is deemed excessive, in which case refers to paragraph [583-1.10.2](#).

583-1.12.6.6 Gross Cost. The gross cost shall include items e, g, h, and j of paragraph [583-1.12.6.4](#). In addition, the repair or purchase of a replacement engine is to be included in the estimate.

SECTION 2

DIMENSIONS, WEIGHTS, AND CHARACTERISTICS

583-2.1 STANDARD NAVY BOATS

583-2.1.1 DIMENSIONS, WEIGHTS AND CHARACTERISTICS. These measurements of U.S. Navy standard boats can be found in the latest edition of the Boat Information Book (BIB) for that particular contract number or class of boats or the latest edition of the unclassified NAVSEA 0900-LP-084-3010 Data Book for Boats and Craft of the United States Navy, which is updated every four years.

583-2.1.2 WEIGHT REPORTING. All standard Navy boats and craft are weighed prior to delivery and this weight is recorded as the Contract Acceptance Weight. For ships' boats, a Design Hoisting Weight is established which includes the Contract Acceptance Weight, the weight of the authorized crew members at 165 pounds each, full fuel tanks, outfitting items, and an allowance for onboard engineering consumables. The hoisting slings and fittings are rated by an engineering evaluation of their mechanical component breaking strengths and failure levels. The weight of the boat should never exceed the Safe Working Load rating of the davits.

583-2.2 REFERENCE FOR OPERATING PERSONNEL

583-2.2.1 IMPORTANT CHARACTERISTICS. Table 583-2-1 furnishes a ready reference for operating personnel of the important characteristics of most Navy boats and craft. The hoisting weights given in this table are not to be used for testing boat-handling davits. All weights given in Table 583-2-1 are average weights and all boats are glass reinforced plastic, unless otherwise noted.

583-2.3 PAINT PUNT PURCHASE DESCRIPTION

583-2.3.1 PAINT PUNT. The punt is a non-powered craft used to inspect the waterline area of a ship while at anchor or in port. The punt is manhandled from its stowed position, and then lowered from the deck to the water by rope pendants secured to the bow and stern handles. Up to three persons with painting or other gear board the punt from the ship's access ladders. The punt is propelled by paddles or positioned using the pendants. Lightweight, stability, resistance to swamping and durability are valued characteristics for the application.

- a. General form: the punt shall be a flat bottom, transom-ended punt or jon boat with bow, center and stern bench seats.
- b. Dimensions:
 1. Length: 13.5 to 14.5 feet (4.1m to 4.4m)
 2. Overall beam: at least 55 inches (1.4m)
 3. Chine beam (bottom width): at least 36 inches (.9m)
 4. Depth: at least 17 inches (.43m) measured vertically (punts designed to accommodate outboard motors may have transom cutout of not less than 15 inches (.38m) depth)
 5. Weight: shall not exceed 200 pounds (90.9kg)
- c. Materials and construction: the hull and structural components shall be manufactured of 5000 or 6000 series aluminum alloy suitable for use in seawater, except that stainless steel fasteners may be used. Use of wood

S9086-TX-STM-010

shall be limited to plywood suitable for exterior exposure, where necessary for backing plates, reinforcement of transoms designed for outboard motors, and similar components. The punt shall be fitted with a minimum of two handles on each end of the punt (four handles total). Handles shall be well rounded to prevent injury to or undue stress on hands. Handles shall be secured to the punt with through-bolts or solid rivets, or may be integral to the hull. Tubular rivets, pop rivets, or self-tapping screws shall not be used to secure handles. Handles shall as a minimum be strong enough to support the entire weight of the punt when suspended from a single handle

- d. Stability and load capacity: the punt shall have a capacity of at least three persons, shall have a total load capacity of at least 600 pounds (persons and gear). The punt shall provide level flotation, and shall have a load capacity plate installed in accordance with the requirements of 33CFR183.
- e. Acceptable products are: Alumacraft 1436 lite, Alumacraft 1436, Alumacraft 1442, Lowe 1436. However, due to the possibility of manufacturing changes, the specifications of the product shall be verified against the requirements of this purchase description before procurement.

Table 583-2-1 Characteristics For Navy Boats And Craft

BOAT/ RAFT	LENGTH FT/M	BEAM	ENGINE (HP/KW)	HEIGHT WITH- OUT CRADLE (FT/M)	FUEL CAP (GALS/ Liters)	MAX SPEED	DESIGN HOIST- ING WEIGHT (LBS/KG)	MAX DISP (LBS/KG)	CARGO CAP (LBS/ KG)	CARGO CAP (LBS/ KG)	CARGO CAP (LBS/KG)
14-foot Aluminum	14'	4' 8"		1' 6"			175	1180			
18'TD OST 33	20' 11"	7' 4"	230	3' 9"	42	42	3850	3850			
18'UB	17' 6"	6' 8"	90	4'	36	27	2200	2600	400	400	400
18' UB (Boston Whaler)	18' 6"	7' 2"	70	4'	54	27	2100	3900	1755	1755	1755
22' UB	21' 10"	7' 9"	50	6'	30	8	5500	7800	2300	2300	2300
22' UB (Stock) (BW)	22' 3"	7' 5"	100	6'	77	30	3000	5655	2655	2655	2655
22' UB (SEAL) (BW)	22' 3	7' 5"	140	6'	127	30	3600	5655	2055	2055	2055
22' UB (EOD) (BW)	22' 3	7' 5	100	6'	127	30	3400	5655	2255	2255	2255
22' UB (STD) (FY 91) Riverine	21" 8"	8' 6"	100	7'	100	31.5	4600	6300	1690	1690	1690
24' HS Alum includes dive plat- form	26"	8"	165	9' 4"	68	25	6450	6800	1150	1150	1150
24' HS Alum gas O/B con- version	29"	8"	100	9' 4"	68	30	6450	6800	1150	1150	1150

Table 583-2-1 Characteristics For Navy Boats And Craft - Continued

BOAT/ RAFT	LENGTH FT/M	BEAM	ENGINE (HP/KW)	HEIGHT WITH- OUT CRADLE (FT/M)	FUEL CAP (GALS/ Liters)	MAX SPEED	DESIGN HOIST- ING WEIGHT (LBS/KG)	MAX DISP (LBS/KG)	CARGO CAP (LBS/ KG)	CARGO CAP (LBS/ KG)	CARGO CAP (LBS/KG)
24' BH Alum includes trim tab guard	25' 3"	8'	260	8'	130	23.5	10500	10,500	500	500	500
24' WB (EOD), Alum	24'	8'	165	8' 6"	68	16	6250	9225	3000	3000	3000
24' RIB MK 1	23' 9"	9	165	6' 9"	35	17	5300	7300	2000	2000	2000
24' RIB MK2	23' 9"	9	165	6' 9"	35	17	5600	7500	1900	1900	1900
24' RIB MK 3	23' 9"	9	175	6' 9"	35	25	5600	7500	1900	1900	1900
7-M RIB *1	23' 9"/7.25	9'/2.74	175/130	6' 9"/2.06	34/130	25/46	5600/2540	7500 /3400	1900/860	1900/860	1900/860
26' MW MK 10 built prior to1980	26' 1"	8' 3"	25	6' 8"11	30	7.5	6400 *4	9300	3000	3000	3000
26' MW MK 10 built 1980-1984	26' 1"	8' 3"	25	6' 8"	30	7.5	7000 *5	9300	3000	3000	3000
26' MW MK 11	26' 1"	8' 3"	25	6' 8"11	30	7.5	6200 *4, *5	9900	3600	3600	3600
26' MW MK 12	26' 1"	8' 3"	25	6' 8"	30	7.5	6200 *4, *5	9900	3600	3600	3600
26' PE (built prior to 1966 "C" hulls	26' 6"	9' 5"	250	9' 4"	90	21	12200	14200	2000	2000	2000
26' PE	26' 6"	9' 5"	250	8' 7"	80	21	11690	13550	2000	2000	2000

Table 583-2-1 Characteristics For Navy Boats And Craft - Continued

BOAT/ RAFT	LENGTH FT/M	BEAM	ENGINE (HP/KW)	HEIGHT WITH- OUT CRADLE (FT/M)	FUEL CAP (GALS/ Liters)	MAX SPEED	DESIGN HOIST- ING WEIGHT (LBS/KG)	MAX DISP (LBS/KG)	CARGO CAP (LBS/ KG)	CARGO CAP (LBS/ KG)	CARGO CAP (LBS/KG)
26' PE MK2	26' 6"	9' 4"	250	8' 8"	90	21	10800	13100	2000	2000	2000
26' PE MK3 (MK2 fit- ted with rigid bail)	26' 6"	9' 4"	250	10' 8"	90	21	11250	13550	2000	2000	2000
26' PE MK4	26' 3"	9' 4"	197	8' 8"	52	21	10000	12000	2000	2000	2000
26' PE MK6	26' 3"	9' 4"	197	8' 8"	52	22	9500	11200	2000	2000	2000
26' PE MK7	26' 3"	9' 4"	204	8' 10"	52	20	9500	10000	2000	2000	2000
8M PE *1	26, 3"	9' 1"	175/130	8' 10"/2.70	52/200	20	8800/4000	10000/ 4500	2000/910	2000/910	2000/910
30'HH MK2	30' 11"	9' 4"	100	7'	80	8	9500	12500	3300	3300	3300
31' RP MK2	32'	11' 8"	215	8' 3"	160	30	17200	19200			
33' PE MK2	32' 9"	11' 4"	250	12' 6"	100	14	16000	19000	3500	3500	3500
33' PE MK4	33' 3"	11' 4"	250	12' 6"	100	13	16000	19200	3500	3500	3500
33' PE MK5	33' 3"	11' 4"	257	12' 6"	100	16	15700	18500	3500	3500	3500
33' PE MK6	32' 9"	10' 11"	257	12' 6"	100	18	15700	17500	3500	3500	3500
33' PE MK7	32' 9"	10' 11"	214	12' 3"	100	17	15700	16000	3500	3500	3500
10M PE *1	32" 9"/ 10m	11'/3.35	214/160	12' 4"/3.75	95/360	18	14350/6500	16550/ 7500	3500/ 1588	3500/ 1588	3500/ 1588
10M RB (NSW)	32" 9"/ 10m	10' 7"/2.06	400/298	6' 9"/2.06	256/970	40	17600/8000	18500/ 8400	4000/1820	4000/1820	4000/1820

Table 583-2-1 Characteristics For Navy Boats And Craft - Continued

BOAT/ RAFT	LENGTH FT/M	BEAM	ENGINE (HP/KW)	HEIGHT WITH- OUT CRADLE (FT/M)	FUEL CAP (GALS/ Liters)	MAX SPEED	DESIGN HOIST- ING WEIGHT (LBS/KG)	MAX DISP (LBS/KG)	CARGO CAP (LBS/ KG)	CARGO CAP (LBS/ KG)	CARGO CAP (LBS/KG)
33'UB MK3	33' 10"	11' 4"	100	7' 6"	100	9	12200	18200	7100	7100	7100
33'UB MK4	33'5"	11'	100	8'	100	9.5	11000	16600	7100	7100	7100
10M UB FY90 *1	33' 10"/ 10.16	10' 9"/3.28	112/84	7' 10"/2.40	90/340	10	11000/5000	17000/ 7700	7100/3200	7100/3200	7100/3200
35' WB Alum twin	37' 1"	11' 1"	100	9' 4"	100	10.5	17500	22200	6500	6500	6500
35' WB Alum twin (FY89)	36' 10"	11' 1"	74	8' 9"	76	10	14700	21100	6500	6500	6500
36' HL (1986 and later)	36'	12' 4"	425	13' 6"	250	18	25300 *4	25100			
36' AT MK1 Alum twin	36'	13'	270 or 465	5' 11"	431	28/32	26000	29300	3200	3200	3200
36' AT MK2 Alum twin	35' 10"	13'	270 or 465	6' 2"	392	28/32	26000	29800	3200	3200	3200
36' PL MK11	36' 1"	13' 1"	270	10' 3"	160	17	18500	20200	3000	3000	3000
36' PL MK12	36' 2"	12' 4"	425	9' 8"	200	17	20000	24600	3000	3000	3000
36' PL MK13	36 feet 1/4 inch	12 feet 2 inches	Detroit Diesel 8V71TI 450 shp at 2300 rpm	9' 8"	200 gallons		22400	24,630			
11M PL	35' 11"/ 10.95	12'/3.67	455/340	9' 6"/2.90	198/750	19	19800/9000	20900/ 9500	3000/ 1360	3000/ 1360	3000/ 1360
36' VP MK7	35' 9"	10' 7"	225	10' 9"	180	9	18500	26600	8100	8100	8100

Table 583-2-1 Characteristics For Navy Boats And Craft - Continued

BOAT/ RAFT	LENGTH FT/M	BEAM	ENGINE (HP/KW)	HEIGHT WITH- OUT CRADLE (FT/M)	FUEL CAP (GALS/ Liters)	MAX SPEED	DESIGN HOIST- ING WEIGHT (LBS/KG)	MAX DISP (LBS/KG)	CARGO CAP (LBS/ KG)	CARGO CAP (LBS/ KG)	CARGO CAP (LBS/KG)
36' PB (SEAFOX) twin	35' 5"	9' 4"	257	8'	280	30	26000	25600	2500	2500	2500
40' PE MK4 MK6	40' 5"	12' 4"	257	12' 9"	160	15	19000	24500	6600	6600	6600
40' PE MK5, Twin	41' 9"	11' 10"	214	12' 6"	180	22.5	22700	28300	6600	6600	6600
40' PE MK7, Twin	41' 3"	11' 11'	214/160	12' 6"	150	22.5	22000	26000	6600	6600	6600
12M PE *1	39' 11"/ 12.17	11' 10"/ 3.61	214/160	12' 6"/3.81	150/570	15	19000/8600	26500/ 12000	6600/2994	6600/2994	6600/2994
40' PR MK43(steel) Twin	41' 1"	11' 9"	250	15' 1"	380	20	26600	28900	2000	2000	2000
40' UB MK3	40' 3"	12' 1"	165	9'	112	10	18000	28500	11800	11800	11800
40' UB MK4,5,and 6	40' 3"	12' 1"	174	9'	112	11	17000	27700	11800	11800	11800
12M UB	39' 11"/ 12.17	11' 10"/ 3.61	175/131	9'/2.74	105/400	11	15400/7000	26900/ 12200	26000/ 11800	26000/ 11800	26000/ 11800
42' PR MK4, Alum, Twin	41' 4"	14' 9"	450	15' 2"	670	25	38000	40900	4000	4000	4000
42' PR MK5, Twin *1	42'	11' 5"	243	17' 11"	498	22	25000	29000	3500	3500	3500
50' DW, Steel	50' 5"	14' 9"	200	15' 2"	400	9	93750	89300			

Table 583-2-1 Characteristics For Navy Boats And Craft - Continued

BOAT/ RAFT	LENGTH FT/M	BEAM	ENGINE (HP/KW)	HEIGHT WITH- OUT CRADLE (FT/M)	FUEL CAP (GALS/ Liters)	MAX SPEED	DESIGN HOIST- ING WEIGHT (LBS/KG)	MAX DISP (LBS/KG)	CARGO CAP (LBS/ KG)	CARGO CAP (LBS/ KG)	CARGO CAP (LBS/KG)
50' DW, MK2 FY89,	50'	14' 2"	173	18' 4"	418	9.5	87800	80300			
50' PF MK1, Alum, Twin	50'	13' 10"	430	17' 6"	800	22	44000	47600			
50' PF MK2, Alum, Twin	50'	13' 10"	430	17' 6"	828	24.5	44000	48400			
50'UB, MK4	50' 2"	14' 11"	160	10' 6"	170	10	27200	23400	4700	4700	4700
50'UB, MK6 MK7	50' 3"	14' 10"	174	10' 6"	170	10.5	24000	47100	23400	23400	23400
15M UB FY90	49' 11"/ 15.21	14' 3"/4.34	175/131	10' 6"/3.20	170/640	11	24000/ 10900	45600/ 20700	23400/ 10600	23400/ 10600	23400/ 10600
50' WB Steel, Twin	50' 3"	14' 5"	200	15' 8"	490	9	56400	95000	38700	38700	38700
56'CM(6) MOD2, Steel, Twin	56"	14' 4"	225	13' 5"	490	10	56000	124700	68800	68800	68800
56'CM(6) MOD2 HPI, Steel, Twin	56"	14' 4"	450	14'	768	11	69600	137600	68800	68800	68800
56'CM(6) MK6 MOD2 HPI (FY86), Steel, Twin	56' 8"	15' 2"	600	14' 4"	768	11	69600	137600	68800	68800	68800

Table 583-2-1 Characteristics For Navy Boats And Craft - Continued

BOAT/ RAFT	LENGTH FT/M	BEAM	ENGINE (HP/KW)	HEIGHT WITH- OUT CRADLE (FT/M)	FUEL CAP (GALS/ Liters)	MAX SPEED	DESIGN HOIST- ING WEIGHT (LBS/KG)	MAX DISP (LBS/KG)	CARGO CAP (LBS/ KG)	CARGO CAP (LBS/ KG)	CARGO CAP (LBS/KG)
63' AR MK3/4, Wood,Twin	63' 4"	15' 4"	630	15' 6"	1580	28	62800 *6	64600	1800	1800	1800
65' AR, Alum, Twin	65'	17' 3"	585	17' 6"	600	24	70000	69400	2400	2400	2400
65' SC (EOD), Alum, Twin *1	64' 6"	19' 6"	270	21'	886	12.5	94400	89400			
65; SC (EOD) MK2, Twin, Al *1	64' 6"	19' 6"	270	21'	886	12.5	94400	89400			
65' PB MK4, Alum *1 (3 engines)	64' 11"	18' 2"	600	19'	1800	25	93000	100700			
65' TR, Alum, Twin	65' 9"	19' 5"	450	21' 6"	1100	12.5	94400	105000	10000	10000	10000
68' PB MK3, Alum, 3 engines,	64' 11"	18' 2"	600	17' 7"	1800	25	93000	100700			
70' PE Twin	70' 7"	21' 2"	174	16'	400	10	*7	90000	28000	28000	28000
70' PE MK2, Twin	69' 8"	20' 8"	228	15' 9"	400	12	78000	85000	25000	25000	25000

Table 583-2-1 Characteristics For Navy Boats And Craft - Continued

BOAT/ RAFT	LENGTH FT/M	BEAM	ENGINE (HP/KW)	HEIGHT WITH- OUT CRADLE (FT/M)	FUEL CAP (GALS/ Liters)	MAX SPEED	DESIGN HOIST- ING WEIGHT (LBS/KG)	MAX DISP (LBS/KG)	CARGO CAP (LBS/ KG)	CARGO CAP (LBS/ KG)	CARGO CAP (LBS/KG)
72' TR, Wood, Twin	72' 9"	17'	500	20'	1800	18	118000	116300	24000	24000	24000
74CM(8) (Mod 2), Alum, Twin	74' 6"	21' 1"	300	14'	870	12	83600	213600	130000	130000	130000
74CM(8) (Mod 3), Steel, Twin, SLEP	73' 7"	21' 7"	400	17' 4"	870	10	1350000	277700	130000	130000	130000
74CM(8) (Mod 4), Alum, Twin, SLEP	74' 6"	21' 7"	400	16' 8"	870	11	83600	231000	130000	130000	130000
74CM(8) MK5, Steel, Twin,	74' 3"	21' 7"	437	17' 1"	1140	12	134400	285000	160000	160000	160000
74CM(8), MK6, Alum, Twin,	74' 4"	21' 4"	350	18' 1"	750	10.6	88000	248000	160000	160000	160000
85' TR Alum, Twin	85"	18' 8"	580	20"	2400	20		135000	22200	22200	22200
85' TR FY77, Alum, Twin	84' 9"	18' 10"	929	22'	2750	18	123000	167400	22100	22100	22100

Table 583-2-1 Characteristics For Navy Boats And Craft - Continued

BOAT/ RAFT	LENGTH FT/M	BEAM	ENGINE (HP/KW)	HEIGHT WITH- OUT CRADLE (FT/M)	FUEL CAP (GALS/ Liters)	MAX SPEED	DESIGN HOIST- ING WEIGHT (LBS/KG)	MAX DISP (LBS/KG)	CARGO CAP (LBS/ KG)	CARGO CAP (LBS/ KG)	CARGO CAP (LBS/KG)
100' TR, Steel, Twin,	102' 9"	24' 3"	850	48"	8690	17		362000	38500	38500	38500
108' YP, Wood	108'	24' 3"	437	54' 9"	6550	13		378600	45000	45000	45000
120' TR, Steel	120'	25'	1140	28' 7"	8700	14		555500	34400	34400	34400
135' CU 1610, Steel, Twin	134' 3"	29' 9"	500	16' 4"	3220	11	414400	800900	376300	376300	376300
135' CU 1627, Steel, Twin	134' 3"	29' 9"	500	16' 4"	3380	11	414400	873600	380800	380800	380800
135' CU 1646, Steel, Twin	134' 9"	30' 1"	500	16' 4"	3460	11	492800	904960	403000	403000	403000
135' CU 1680, Steel, Twin	134' 9"	30' 1"	425	17' 4"	3460	11	492800	904960	403000	403000	403000
19' Barrier Boat	19'	10'	260		180			22000			
22' Barrier Boat	25"	11'	260		120			36500			
25' Barrier Boat	25'	13' 8"	450		400			45000			
36' Escort Boat (Catamaran hull)	36' 5"	12' 8"	370		300	27		17300			

Table 583-2-1 Characteristics For Navy Boats And Craft - Continued

BOAT/ RAFT	LENGTH FT/M	BEAM	ENGINE (HP/KW)	HEIGHT WITH- OUT CRADLE (FT/M)	FUEL CAP (GALS/ Liters)	MAX SPEED	DESIGN HOIST- ING WEIGHT (LBS/KG)	MAX DISP (LBS/KG)	CARGO CAP (LBS/ KG)	CARGO CAP (LBS/ KG)	CARGO CAP (LBS/KG)
7M RIB (Hull Numbers 0101 to 0114 and 0120 to 0124)	7.24m	2.74	180/134		34/132		2540	3500			
7M RIB (Hull Numbers 0115 to 0119)	7.24m	2.74	180/134		34/132		2540	3500			
7M RIB (Hull Numbers 0201 to 0232)	7.24m	2.74	180/134		34/132		2540	3500			
7M RIB (Hull Numbers 0252 to 0271)	7.24m	2.74	180/134		34/132		1931	3319			
7M RIB (Hull Numbers 0222 to 0283)	7.24m	2.74	180/134		34/132		1930	3319			
7MRX	7.24m	2.75	180/134		130L		2540 (Caley Davit Sys- tem)	3500			
7MRX FY01	7.24m	2.73	180/134		130L		1930	3319			

Table 583-2-1 Characteristics For Navy Boats And Craft - Continued

BOAT/ RAFT	LENGTH FT/M	BEAM	ENGINE (HP/KW)	HEIGHT WITH- OUT CRADLE (FT/M)	FUEL CAP (GALS/ Liters)	MAX SPEED	DESIGN HOIST- ING WEIGHT (LBS/KG)	MAX DISP (LBS/KG)	CARGO CAP (LBS/ KG)	CARGO CAP (LBS/ KG)	CARGO CAP (LBS/KG)
11M RIB with lifting frame (LPD) (FY01)	11 (36' 2")	3.5 (11' 8")	355 bhp		180		6260/ 13,912 (Caley Davit Sys- tem)	8244.9/ 18322			
11M RIB (with cabin)	37' 9"/11.51	12'/3.6	380		265	33	17,640	19000			
11M RIB (with out cabin)	39/11.9	11' 10"/3.6	380		265/1000	33	17640	22000			
27' HSB (IB with jet)	31' 6"	10' 2"	355		75	32	8280	11320			
27'HSB (out board)2001	30 feet (Including protection bar)	10' 6"	O/B		98	32.8	7200	10240			
27'HSB (out board)2002	31 feet (Including protection bar)	10' 6"	O/B		100	32.8	7200	10,240			
28' HSB	31' includ- ing protec- tion bar	11' 9"	O/B 225 hp		200		13800				
8M HSB Alum Hull, outboard engine	28' 7 " (including protection bar)	9'	O/B		100	35	7000	10000			
8M HSB	28 ' 91/4" (w/protect- ion bar)	25 feet 2-1/4 inches	Twin out- board		100 gallons	35 knots	6500	10,000			

Table 583-2-1 Characteristics For Navy Boats And Craft - Continued

BOAT/ RAFT	LENGTH FT/M	BEAM	ENGINE (HP/KW)	HEIGHT WITH- OUT CRADLE (FT/M)	FUEL CAP (GALS/ Liters)	MAX SPEED	DESIGN HOIST- ING WEIGHT (LBS/KG)	MAX DISP (LBS/KG)	CARGO CAP (LBS/ KG)	CARGO CAP (LBS/ KG)	CARGO CAP (LBS/KG)
10M HSB	33 feet (Including protection bar)	10'5"	315		200 gallons	39 knots	13,600				
40' SWATH (Area Search Craft)											

***NOTES:**

1. The weight of a SEAL with full combat load is 270 pounds. The weight of a Marine with full combat load is 225 pounds. These craft are hoisted at the davits in a fully loaded condition at the slings in the hoisting condition. All weights are approximate and should not be used for design purposes.
2. Light ship condition.
3. Life saving crew of five plus two rescued, total seven persons.
4. Hoist weight for 26 MW MK 10, MK 11, and MK 12 boats built from 180 through the present include allowances for the lifeboat party (7 personnel and gear)
5. Hoisted with cradle.
6. Cannot verify weight from existing data.
7. Capacities for forward compartment of MWB's 6, 7, 9, and 10 are 11 men.
8. Characteristics are taken from specifications and contract drawings if provided.

SECTION 3

REGISTRY NUMBERS AND IDENTIFICATION MARKINGS

583-3.1 REGISTRY NUMBERS

583-3.1.1 NAVSEA ASSIGNED REGISTRY NUMBERS. Each boat is assigned a registry number by PMS 325. The registry number can usually be found on the transom of each craft. Before 1965, the hull registry numbers were serial numbers as assigned to commercial small powerboats (for example, C 3713). These numbers are utilized for accountability (OPNAV INST 4780.5 series) and are normally separate from identification markings assigned by operating activities. After 1965, identifying hull registry numbers consist of the boat length in feet, boat type, and serial number. The first numerals in the boat's identifying numbers signify boat length followed by letters identifying boat type (as 26MW). The final series of numbers indicate year of contract award or option year award (first two digits) and boat number (in sequence of its completion) starting with 01 or 1. This number should be referred to for the completion of all forms.

EXAMPLE: 28HS0201 is the first harbor security boat delivered under a 2002 boat acquisition contract. Under the new metric system for measuring boats, 11MRX0002 is the second 11-meter rigid inflatable boat delivered under a 2000 boat acquisition contract.

583-3.1.2 APPLICATION FOR REGISTRY NUMBER FROM NAVSEA. In case a boat is found to be without a registry number, application should be made to NAVSEA to determine hull registry number or to have one assigned.

583-3.2 IDENTIFICATION MARKINGS

583-3.2.1 STANDARD MARKINGS. The U.S. Navy hull registry numbers (Figure 583-3-1) shall be clearly marked on the transom of each boat. Hull registry number marking is approximately 2 to 3 inches in height (50 to 75 mm) and applied in a location that provides readily visible identification.

- a. Paint used for numbers and letters should conform to MIL-PRF-24635C. See NSTM Chapter 631, Preservation of Ships In Service-Surface Preparation and Painting for additional information.
- b. Letters and numbers may not be shaded.

S9086-TX-STM-010

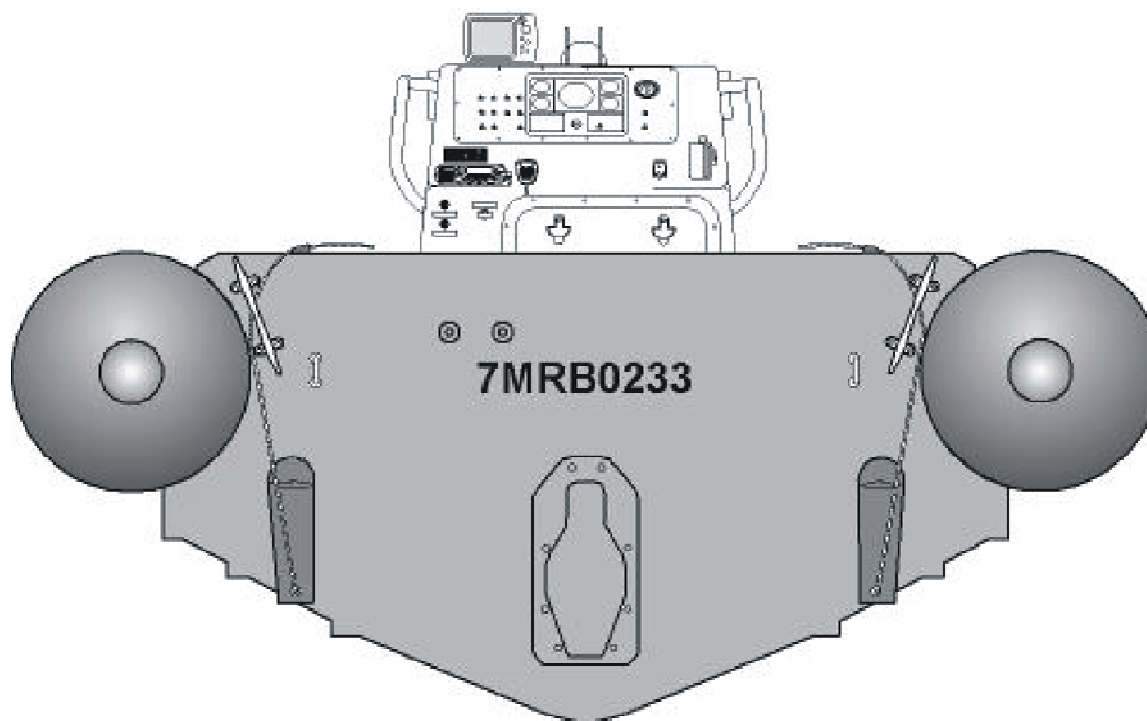

Figure 583-3-1 Hull Registry Numbers a.

583-3.2.1.1 Flag Officer Flag officers' barges shall be marked as follows:

- a. Chrome stars shall be fitted on the bow according to the arrangement on the admiral's flag. The stars shall be of the size and spacing shown on Standard Boat Detail, Sheet 21 (C&R) Drawing 220598).
- b. The official abbreviated title of the command shall appear on the transom in gold leaf decal letters (for example, Surface Force, Atlantic (SURFLANT)).

583-3.2.1.2 Unit Commander. The insignia on boats assigned for the personal use of unit commanders not of flag rank, shall be as follows:

- a. Broad or burgee command pennants, as appropriate, shall be fitted on the bow, with the squadron or division numbers superimposed, together with chrome arrows according to Standard Boat Detail, Sheet 7 (C&R) Drawing 258943).
- b. The official abbreviated title of the command shall appear on the transom in gold leaf decal letters (for example, Destroyer Squadron TWO (DESRON 2)).

583-3.2.1.3 Chief of Staff. The gig for a Chief of Staff, not of flag rank, shall be marked with the official abbreviated title of the command in chrome letters with an arrow running fore and aft through the letters. The letters shall be according to Standard Boat Detail, Sheet 21 (C&R) Drawing 220598). Other boats assigned for staff use shall be similarly marked except that the arrows shall be omitted and the letters shall be brass (bright).

583-3.2.1.4 Commanding Officer. Boats assigned to Commanding Officers of ships shall be marked on the bow with the ship type or name (refer to paragraph 583-3.2.1.5) and number in chrome letters and numerals with a chrome arrow running fore and aft through the markings. Officers' boats shall be similarly marked except that the arrow shall be omitted and the letters shall be brass (bright). The ship's name, abbreviated name, or initials may be used in place of the ship's type. An assigned boat number may be used in place of the ship's name.

583-3.2.1.5 Ships' Boats. Other ships' boats shall be marked on the bow with either the ship's type and number, followed by a dash, and the boat number, such as CV 37-1, or the ship's name, abbreviated name or initials, followed by a dash, and the boat number, such as NIMITZ-1. These markings should also appear on the transoms of all boats, except whale boats. Letters and numbers shall be of brass, and may be painted black or chrome plated. Type commanders shall designate which of the above methods of markings shall be used on the boats assigned to ships under their command. The method of marking shall be uniform for all ships of the same type assigned to the same command.

583-3.2.1.6 Miscellaneous. Painted boat numerals shall be used on miscellaneous small boats such as line handling boats and punts. See Section 10, Table 583-10-2 for recommended colors for painting the barges and gigs.

583-3.2.2 BOATS AND CRAFT ASSIGNED TO SHORE STATIONS. Naval Base Commanders may assign blocks of numbers to the individual activities within their district for permanent assignment to the boats suballotted to the various activities. The activity may assign, to each allowed boat, a consecutive number.

583-3.2.2.1 Shore Station. As an alternative to the foregoing, individual shore stations may use the name or abbreviated name of the station, on each bow followed by a number commencing with one and running consecutive through the total number of boats assigned.

Example: NS KEYWEST 1, NS KEYWEST 2, and so forth.

583-3.2.2.2 Shore Based Command. Personnel boats for shore-based commands will normally carry the same command insignia prescribed for forces afloat on each bow. In addition, they will carry the command abbreviation and location of the command neatly lettered on the transom. Personnel boats assigned names will carry the name displayed on each bow, and the command abbreviation and geographical location of the command on the transom. Gigs will carry the abbreviated name of the command in chrome letters, struck through with a chrome arrow on each bow and the location of the command on the transom in gold leaf decals. Refer to Section 10, Table 583-10-2 for recommended colors for barges and gigs.

583-3.2.3 IDENTIFICATION MARKINGS FOR COMBATANT CRAFT. Combatant craft will have applicable numbers painted at bow location port and starboard and at centerline of stern.

583-3.2.3.1 Painting. Color of numbers shall be such as to provide nominal contrast with the craft color scheme, acceptable to the individual command.

SECTION 4

BOAT CAPACITY, OPERATING INSTRUCTIONS AND SAFETY PRECAUTIONS

583-4.1 BOAT CAPACITY

583-4.1.1 BOAT REGISTRY AND BOATALT LABEL PLATES. Every boat in the naval service should be fitted with a label plate, which provides data concerning its design, manufacture, and maximum capacity. The maximum capacity designated on the label includes the boat crew and assumes that all passengers are in the cockpits and are seated. A BOATALT label plate (Figure 583-1-3) shall be provided according to paragraph 583-1.6.9. Boat Information Books (BIB's) are provided with most U.S. Navy boats and craft. The BIB provides general configuration, operational, and maintenance information. It contains guidelines on the safe operation and proper maintenance of the specific boat or craft. The BIB is designed for use at the organizational level to support boat and craft crews.

583-4.1.1.1 Registry Plate Format. Boat registry plates on standard boats will be of sheet 316L CRES grade, approximately 6 inches by 2-1/4 inches with engraved letters approximately 5/16 inch high, filled with black sealing wax. The data on the label plates will be formatted as follows (the exact data to suit the particular boat): 33-FOOT PERSONNEL BOAT, MK5 Boat Registry No. 33PE8028 built for the United States Navy, Builder, City, Month, Year, NAVSEA DWG 33PE MK5 101-5703535, Crew 3 persons, Capacity 24 persons (including crew).

583-4.1.1.2 Drawing Number. The Naval Sea Systems Command (NAVSEA) drawing number shall be the general arrangement plan from which the boat was built. In case the inboard profile, deck, and sections are not all on the same drawing, the drawing number of the inboard profile should be used. The general arrangement or inboard profile drawing will refer to the other drawings of the set.

583-4.1.1.3 Commercial-Off-The-Shelf (COTS) Boat Drawings. Boat builders provide drawings for use and are not assigned a NAVSEA number, but are listed by drawing number and title in the Boat Information Book (BIB).

583-4.1.2 DETERMINATION OF CARRYING CAPACITIES. The carrying capacity (established by NAVSEA) of a pulling boat is determined by calculating the internal volume of the boat in cubic feet and allowing 10 cubic feet of such volume for each man carried. It is assumed that each man will be wearing a lifejacket and 165 pounds will be allowed for each man so equipped. Boats used to support Vessel Boarding Search and Seizure/Maritime Interdiction VBSS/MIO duties shall not be overloaded.

583-4.1.2.1 Boats and Craft. In the case of boats and craft, the preceding determined capacity shall be decreased by the number of men which would equal the total weight of machinery (wet), fuel, engine accessories and equipment, outfit, and parts of hull not ordinarily found in a pulling boat.

583-4.1.3 WEIGHT CONSIDERATIONS. The Navy Standard 7 meter (24') RIB maximum weight (Full Load Condition) consists of the carrying capacity, which is 1350 kg (2970 lbs), or the equivalent of eighteen persons (including crew) at 75 kg (165 lbs) each plus full fuel and slings. The Navy Standard 7 meter (24') RIB maximum hoisting weight (Hoisting Condition) consists of 375 kg (825 lbs), or the equivalent of five persons (including crew) at 75 kg (165 lbs) each plus full fuel and slings. Maximum Hoisting Condition reflects the Lifeboat

S9086-TX-STM-010

(also called: Man Overboard, Search and Rescue) Party loadout. Lifeboat Party consists of full fuel, security package (Small caliber automatic weapon and ammunition), slings and five persons at 75 kg (165 lbs) each as follows:

- a. Coxswain
- b. Bow Hook/Swimmer/Corpsman
- c. Stern Hook/Engineer
- d. Boat Officer
- e. Rescued Individual Maritime Interdiction/Vessel Boarding Search and Seizure Operations, Security operations Anti-Terrorism/Force Protection - MIO/VBSS or AT/FP Party loadout consists of the maximum carrying capacity of 1350 kg (2970 lbs) or the equivalent AT/FP party (including equipment and crew) plus full fuel and slings.

583-4.1.4 CAPACITY NOT TO BE EXCEEDED. When carrying liberty or boarding parties (VBSS/MIO), the designated carrying capacity should never be exceeded. In carrying stores or boarding parties, the load in pounds, including crew and stores or gear, should never exceed the maximum allowable cargo load, as given on the boat label or as listed in Table 583-2-1. In motorboats, the practice of carrying passengers, stores, or baggage on the topsides should be prohibited. When it is necessary to carry stores or baggage, a corresponding reduction in maximum number of passengers should be made.

583-4.1.4.1 Flotation Material. The installation of flotation material shall not be considered as relieving operating personnel from exercising sound judgment in the loading of boats or providing of lifejackets when conditions warrant. Since the amount of flotation material to be installed is limited by the space available in the boat, it has been possible to provide a reserve buoyancy of only 22 pounds per man. In rough seas, the boat should be loaded to less than capacity so that this margin of reserve buoyancy will be somewhat greater. Twenty-two pounds will support a seated man submerged in water approximately to his armpits. With water this high, there will be a tendency for passengers to stand up, which could result in the sinking or capsizing of the swamped boat. If lifejackets are worn, personnel near the sides may take to the water and hold onto the gunwale. Other personnel should remain seated to avoid overcrowding around the outside.

583-4.1.5 HANDLING OF STORES. On small ships, such as destroyers, submarines, and mine sweepers, limited availability of ships' boats frequently renders it necessary (for purposes of economy) for stores and liberty parties to be carried together. For the benefit of personnel, and particularly coxswains, the following example is presented. Example: Assume that the coxswain of a 26-foot motor whaleboat (MK11) is ordered to make a shore trip to pick up stores weighing approximately 2,000 pounds, and to pick up a liberty party. The rated capacity of a 26-foot motor whaleboat (MK11) is 22 men, or, in terms of pounds of stores, 22 times 165 or 3,630 pounds. The coxswain should, therefore, pick up the stores (approximately 2,000 pounds) and bring back not more than eight persons as passengers for: $(3,630 - 2,000)/165 = 9.9$ or 10-2 crew = eight passengers. Operating personnel should be familiar with the designated carrying capacity of the boat and be able to calculate the load and regulate the number of men accordingly.

583-4.1.6 REDUCTION IN CAPACITY. The rated capacity designated on the label plate, represents the maximum capacity under normal weather conditions in sheltered waters. Reduction of capacity is always necessary for extreme weather conditions or in the open sea. Frequently, conditions will be such as to greatly reduce this rated capacity (see Table 583-2-1).

583-4-2

583-4.2 OPERATING INSTRUCTIONS

583-4.2.1 INTERNAL BUOYANCY OF LIFE RAFTS. Open boats, to be acceptable as life rafts under the U.S. Coast Guard Regulations, shall be provided with internal buoyancy according to the Code of Federal Regulations. Title 46; Chapter 1, Shipping; Subchapter Q, Subspecification Part 160.035, Lifesaving Equipment.

583-4.2.2 LIFE PRESERVERS STOWED IN BOATS. Except for small landing craft (other than VP), which are not fitted to stow life preservers for passengers, life preserver stowage in boats is established upon 50 percent allowance of maximum boat capacity. This is based on the following:

- a. Suitable stowage space is not available for 100 percent allowance.
- b. The maximum number of persons permitted to be carried is a matter of ship's administration based upon the boat's loading and boating conditions. One life preserver for each crewmember shall be aboard before embarking. When conditions warrant, boat passengers shall be issued life preservers before embarking.
- c. The number of life preservers shall be drawn from the regular ship's allowance. Conditions under which life preservers are carried may vary to a considerable degree; thus, they have not been included as items of boat outfit. Boat personnel should frequently (particularly after wet weather, or when spray has entered the boat) break out all stowed life preservers for drying and airing out.

583-4.3 BOATS AND SMALL CRAFT FIRE HAZARDS

583-4.3.1 LIST OF FIRE HAZARDS. A fire is serious at any time, but in a gasoline or diesel powered boat; it has a more fatal aspect. Boats are equipped with firefighting devices; but the best safeguard to those concerned with the handling of boats is recognition of the hazard and knowledge of the cause. This information may then be used to prevent conditions leading to a fire. The following is a list of fire hazards that exist. Each will be discussed in detail.

- a. Gasoline
- b. Clothing and oily waste or rags
- c. Fuel leaks
- d. Ventilation
- e. Fueling
- f. Bilges and sumps
- g. Exhaust pipe
- h. Dirty engines
- i. Defective electric wiring
- j. Battery charging
- k. Smoking

S9086-TX-STM-010

583-4.3.2 GASOLINE. As gasoline vapor is highly combustible when mixed with air, the use of gasoline for cleaning the engine or bilges is strictly prohibited. A spark, caused by smoking or various other sources, may ignite the fumes and cause a dangerous fire.

583-4.3.2.1 Containers. Inspect portable gasoline containers periodically for any leaks. If leaky containers are found, transfer their contents immediately to a tight container. Leaky, defective gaskets and plugs should be replaced. Water should not ordinarily be introduced into a gasoline drum but if a leaky container cannot be made tight by tightening up on the filling and vent plugs, or repairs are required involving the application of heat, the drum should first be filled with water, emptied, and blown through with a steam or air jet to eliminate any vapor present. Repairs to gasoline drums or containers are not ordinarily required to be made by ships' force as they are repaired at their distribution depots. Before making shipment of empty containers, inspect them carefully to see that they are tight and that all plugs are tightly secured. Unless this is done, empty containers constitute a fire hazard to the carrier. Refer to NSTM Chapter 542, Gasoline and JP-5 Fuel Systems.

583-4.3.3 CLOTHING AND OILY WASTE OR RAGS. Keep engine room clear of clothing. Cleaning rags and waste shall be kept in a closed container and disposed of in accordance with the hazardous material guidelines. Clean engines, clean engine rooms, and clean bilges are requisites of efficient boat engineering.

583-4.3.4 FUEL LEAKS. The presence of fuel in the bilges or in a free state in a boat is dangerous. The fumes may be ignited easily and fire results. Free fuel may come from leaks in the fuel lines or units of the system, or result from filling the fuel tanks too full. Fumes shall be disposed of by proper ventilation.

583-4.3.4.1 Shutoff Valves. Fuel lines, connections, and fittings shall be kept tight. Follow manufacturers recommendations and instructions for sealing connections and fittings. Fuel lines in all cases, shall be fitted with shutoff valves installed near the fuel tank and so fitted as to be readily accessible for closing in an emergency. Shutoff valves are to be fitted with extension rods and operating hand-wheels so that they may be operated from a convenient location outside of the probable fire area.

583-4.3.4.2 Fuel Tanks. Fuel tanks shall be tested and inspected annually especially in boats where access to the tanks is limited.

583-4.3.4.3 Components of the Fuel System. Components of the fuel system include, but are not limited to, connections, electrical connections and wiring, hoses, piping, sending units, valves, and mounting hardware. Components should be inspected prior to operation of the boat or fueling.

583-4.3.4.4 Stowages. Anchors or other heavy items should not be stowed near fuel lines because of the danger of them striking lines or fittings and causing leaks. Lightweight items, such as lifejackets, should not be stowed on top of fuel lines, since such stowage interferes with inspection.

583-4.3.5 VENTILATION. The importance of proper ventilation to expel all fuel fumes cannot be overemphasized.

583-4.3.5.1 Leakage. On various craft using gasoline as fuel, there exists danger of explosion and resulting fire due to carburetor flooding, leaky gasoline lines, strainers or tanks, and overflow during fueling. This involves a very serious fire hazard and is as dangerous as other explosives aboard ship.

583-4-4

583-4.3.5.2 Gasoline Vapor. Gasoline is a highly volatile liquid, which will give off a flammable vapor if left exposed to the air. Gasoline vapor is about three times as heavy as air and the highest percentage is found in the lowest places. The mixture will gradually spread throughout the whole boat. The mixture, formed by gasoline vapor and air, is highly explosive in character and only needs a slight spark or flame to cause a violent explosion and fire.

583-4.3.5.3 Vapor in Bilges. All personnel are to strictly observe the safety precautions relating to the use and handling of gasoline. Practically all fires can be traced to the presence of explosive gasoline vapors in the bilges. Evidence shows that this condition frequently occurs immediately after taking on fuel.

583-4.3.5.4 Explosive Sparks. In a gasoline engine installation, there is the possibility of gasoline vapors being present continuously, especially in the lower spaces. The danger of a spark necessary for an explosion is always present and cannot be eradicated. A spark, so minute as to be invisible to the eye, may be formed by striking a nut with a wrench, by arcing of the brushes of a motor or generator, by grounds or shorts in electric circuits, by opening or closing electric switches, by static electric charges formed by the rubbing of two surfaces together, or by nails in shoes hitting or rubbing metal. Sparks may be produced in so many ways that the only insurance against explosion and fire is to take every precaution to prevent the accumulation of gasoline vapors in the boat and this can be done with proper ventilation.

583-4.3.6 FUELING. Except in emergencies, gasoline boats should not fuel unless in the water, with engines stopped, clear of other boats, and where possible, near enough to the ship to receive aid if needed.

583-4.3.6.1 In the Skids. In an emergency, if it is necessary to fuel a boat in the skids, the following safety precautions, in addition to those described in paragraph [583-4.3.6.5](#) shall be observed.

- a. Adequate firefighting equipment shall be provided at the scene.
- b. An Aqueous Film Forming Foam (AFFF) system shall be activated and an AFFF hose shall be charged and laid out at the scene. If an AFFF hose is unavailable, an acceptable alternative is a fire hose rigged with an AFFF in-line eductor at the fireplug with a minimum of three 5-gallon containers of AFFF concentrate.
- c. If practical, a rubber hose, thoroughly grounded to the supply tank or drum and the boat's tanks, should be used for transferring gasoline.
- d. Where the use of a grounded rubber hose is not practical, and a separate container will be used to pour gasoline into the boat's tanks, the supply tank or drum should be interconnected by a flexible conduction wire of sufficient length. After emptying portable containers, inspect them to ensure that all gasoline has been drawn off and then close them tightly by setting up on the filling and vent plugs.

583-4.3.6.2 Passengers Aboard. Boats shall not be fueled with passengers aboard.

583-4.3.6.3 At Night. Except in emergencies, boats shall not be fueled at night.

583-4.3.6.4 Heat Producing Sources. No smoking and no naked lights (such as produced by oil lanterns, candles, matches, lighters, exposed electric switches, slip rings, commutators of a dynamo, or by any burning material involving heat) shall be permitted in the vicinity while fueling in a compartment containing a gasoline engine or a bilge, or elsewhere within 50-feet of gasoline storage tanks or of gasoline vapor.

S9086-TX-STM-010

583-4.3.6.5 Drums and Containers. Gasoline shall not be transferred to a boat from a drum or portable container unless the container has been removed from the proximity of other containers, except in the cases of vessels where drums are stowed in quick releasing racks. In this case, the drum shall be left in its rack when fueling boats. An adapter shall be provided with a standard iron pipe screw thread on one end to fit the opening in a standard gasoline drum; the other end to be fitted with a Navy standard hose thread to take a standard 1-1/4-inch inside diameter flexible metallic hose covered with rubber fabric. Hose will be furnished in 25-foot lengths having couplings and nozzles with Navy standard threads. Standard gasoline filling hose nozzles are the wet hose type that will release gasoline only when the operating lever is gripped and will automatically cut off the flow when the lever is released. Due to this instantaneous control of the flow, the over filling of tanks can be readily avoided. Overflow of the tank should be avoided, especially on boats where the filling is located inboard. In decked over boats and motor launches, the filling fitting is located on deck and overflow gasoline will pass overboard and not into the bilges.

583-4.3.6.6 Grounding Wire. To avoid danger of ignition of gas from a static spark, the filling hose nozzle may have a grounding wire fitted at the end with a spring clip. This clip should be clamped on the screw provided in the deck flange of the filling connection for grounding the hose nozzle, before unscrewing the cover of the filling connection. This connection will equalize electric potential. The ground should be maintained throughout the fueling operation and until the hose has been withdrawn and the filling flap closed. The use of a funnel increases the danger from sparks. It is preferable to insert the nozzle of the grounded hose directly into the filling opening. When fueling funnels are used, they shall be fitted with 40-mesh wire gauze strainer.

583-4.3.6.7 Passing a Drum to Boat. It is not considered good practice to pass a gasoline drum to a small boat for the purpose of fueling. The boat presents an unstable platform and spilling of gasoline is almost inevitable. When such an arrangement is considered necessary due to prevailing conditions, care should be taken that the nozzle of the hose is entered into the filling pipe before gasoline is released.

583-4.3.6.8 Fueling Procedures. The following procedures should be observed when fueling a boat:

NOTE

Before beginning, brief each member on the correct procedures that must be observed while fueling.

- a. See that no passengers are on board.
- b. Close all engine covers to prevent vapors from entering engine spaces.
- c. Inspect tanks and filling pipes and hoses. Do not fuel unless these are tight at the connection points.
- d. Close shutoff valves at tanks.
- e. Close all doors, hatches, windows, and other openings to ensure that fuel vapor does not enter or become trapped in closed compartments.
- f. Attach the spring clip on the end of the hose ground wire to the screw provided on the deck flange of the filling pipe (refer to paragraph [583-4.3.6.6](#)). The grounding screw is not required on diesel engine boats.

- g. One member of the boat crew shall be tasked to stand by with a portable dry chemical fire extinguisher ready for use. Extinguisher is not to be returned to stowage position until fueling is completed and engine is operating satisfactorily.
- h. Remove the filling pipe cap. Sound the tank to determine the approximate amount of fuel required to fill the tank.
- i. Insert the hose nozzle into the fill point. Open the nozzle valve and begin filling the tank.
- j. If for any reason the hose nozzle is withdrawn from the fill point during fueling and the ground wire becomes detached from the grounding screw, the grounding wire shall be reattached to the screw before the nozzle is inserted into the fill point. (Diesel boats do not have the grounding screw but may be required to attach a grounding clip.)
- k. The nozzle shall be manned and kept under control to ensure that the fuel flow rate is acceptable to prevent overfill and spilling at all times. Diesel oil passes through the strainer more slowly than gasoline.
- l. When the tank is filled, withdraw the nozzle from the fill point and secure the cap as applicable.
- m. Detach the ground wire.
- n. If fuel spill has occurred wash/wipe down in accordance with current policy and guidelines.

583-4.3.6.9 Before Starting Engine. Before starting the engine, it is particularly important to clear the boat compartments and bilges of any gasoline vapor that may be present from the fueling operation.

WARNING

Operate exhaust fans for at least 4 minutes before starting engine, and check engine compartment bilge for gasoline vapors. The following procedures should be observed before starting engines:

- a. **Open the engine covers to permit circulation of air to dissipate fuel vapors. The same precautions apply if gasoline vapor is noticed in the boat while underway. Gasoline fires have occurred through ignition by sparks from some part of the electrical equipment while the engine is turning over. It is safer for both personnel and material to stop and clear out gasoline vapor and to remove its cause rather than to continue running the engine. When stopped for this purpose, one of the crew should stand by ready to operate the fire extinguishing equipment. This is particularly important with motorboats having closed engine compartments.**
- b. **If gasoline is spilled during fueling and runs into the bilges, the bilges should be washed down, pumped, wiped out, and aired thoroughly before the engine is started.**

583-4.3.6.10 Shore Station Fueling. The same general precautions should be observed when fueling from shore stations. Serious fires have occurred due to the absence of grounding connections. Before permitting a gasoline engine boat to fuel, an inspection of such stations should be made by the officer or petty officer in charge of the boat to see that grounding connections are provided either by the boat or by the station. These grounding con-

S9086-TX-STM-010

nections should be of wire or solid metal and care should be taken to see that the contacts are positive. Wrapping wire around the metal parts of the filling, hose is not sufficient and the use of chains is not considered a positive method.

583-4.3.6.11 Lighting. Only approved lighting shall be used during fueling operations.

583-4.3.6.12 Flame Screen. Tank wire gauze in the filling connection is a flame screen designated to minimize possibility of a flame flashing into the tank from some outside source. It should always be kept in place.

583-4.3.7 BILGES AND SUMPS. Bilges and sumps shall be kept dry and frequently washed out to clear them of fuel and oil. They should be washed before hoisting into the boat skids. The space directly under the engine can be readily washed down by using hot water or a steam hose. This method will carry heavy oil and grease over into the sump from which it can be pumped. Oily bilge water should be pumped to a location where the oil can be separated from the water rather than pumped over the side of the ship. Frequent inspections of engine room bilges should be made to ensure that residue is not present. The forward and after engine space bulkheads should be inspected for tightness in the bilges in order that liquid and gas may be prevented from passing over into adjacent compartments.

583-4.3.8 EXHAUST PIPE. Improper insulation of the dry exhaust pipe, where it passes through the hull, may set the boat on fire. A poorly insulated exhaust pipe may set fire to nearby objects or ignite gas fumes if the hot pipe is exposed to gas in the engine room. Any defects of this type should be corrected immediately. Exhaust pipes should be properly insulated with refractory felt, covered by glass cloth, and attached with nonconductive fittings.

583-4.3.9 DIRTY ENGINES. Greases and oil with which an engine becomes encrusted are sources of danger if not cleaned at regular intervals. These petroleum products will feed a fire, enabling it to get out of control rapidly.

583-4.3.10 DEFECTIVE ELECTRICAL WIRING. Electric wiring shall not be permitted in the bilges or engine spaces. Care should be exercised to reduce sparks to a minimum. Sparks may be caused by static charge electricity, short circuits in electric wiring, grounds, striking steel with hand tools, striking of shoe nails on steel, opening and closing switches, and so forth. The battery box shall be located outside of a closed engine compartment, where practicable, and should be provided with a suitable drip proof cover. All naked electric terminals shall be wrapped with insulating tape.

583-4.3.11 BATTERY CHARGING. Charging of batteries will produce sufficient hydrogen gas, which, if trapped and ignited, will produce an explosion. This applies particularly to boats having their batteries under the seats of the after part of the boat. If the battery is charged (other than from the boat engine generator) while in the boat, hydrogen may collect under the seats and, if not removed, may be ignited by a spark from the battery caused by a loose terminal or when charging wires are disconnected. Batteries should either be charged on deck or removed to an open space in the boat until the operation is completed. The battery box should be well ventilated.

583-4.4 SAFETY PRECAUTIONS

583-4.4.1 GASOLINE VAPOR. Most gasoline fires and explosions in boats occur when engines are started which is due to an accumulation of gasoline vapor in the bilges. Exercising proper safety precautions can prevent such fires and explosions. **WARNING** No list of precautions can provide for every conceivable situation that might arise. The only adequate safety precaution is a constant awareness of the hazards and a consistent application of common sense to situations that arise.

583-4.4.2 CLOSED ENGINE ROOM. Except in an emergency, a boat with a closed engine room should not be operated without the engineer being onboard at his station.

583-4.4.3 ELECTRIC CONNECTIONS. At least once a day during periods when the boat is in use, inspect to see that all electric connections are in place and secured. Electric cabling shall be secured with clamps to prevent movement and resultant wear of any cable in contact with metal surfaces and the attendant danger of short circuits. The inspection should be made any time the operator has reason to believe the cable or connections may have been loosened by operating conditions, passengers or cargo.

583-4.4.4 FUEL PIPING AND TANK FITTING. At least once a day, during periods of operations and at any time the operator has reason to believe damage may have occurred, the fuel lines, strainers, and tank fittings should be inspected for possible leaks and loosening of tanks in the saddles. Fueling connections shall be tight in the tank and the filling cap in place. Any opening in the top of the fuel tank through which fuel may slop out due to rolling or pitching, or through which fuel vapor may be forced out during fueling operations, shall be tightly plugged. Any defects discovered during inspection shall be remedied immediately.

583-4.4.5 WIRE GAUZE SCREENS. At least once a day, during periods when the boat is in use, inspect to see that wire gauze screens are intact and clean. On gasoline engines, screens over carburetor and breather pipe connections shall be securely clamped so they cannot be blown loose in case of backfire or crankcase explosion. Backfire screens shall be installed according to the latest NAVSEA instructions.

583-4.4.6 CARBURETOR DRIP PAN (GASOLINE ENGINES ONLY). The drip pan should be inspected, emptied, and washed. This should be done when the engine is stopped, at intervals when the boat is running, during the day, and before it is hoisted to its cradles. Drip pans are safe only when kept empty.

583-4.4.7 BILGES AND SUMPS. Bilges and sumps should always be inspected before the engine is started. If they are not dry and free from fuel, vapor, and oil, they should be pumped and dried out. If gasoline is spilled in the boat during fueling, the bilges should be flushed down with water, pumped, and wiped dry before starting the engine.

583-4.4.8 VENTILATION. On gasoline engine boats, ventilation is of prime importance at all times. All spaces subject to accumulation of gasoline vapor shall be inspected and thoroughly ventilated. Before the engine is started, every precaution should be taken to ensure that the bilges are open to ventilation, and that any gasoline or gasoline line vapors in bilges and sump are removed. Explosion proof exhaust fans are required on all gasoline engine boats and should be run at least 4 minutes before the engine is started, intermittently for at least 1 additional hour daily, and at any time the presence of gasoline vapor is suspected. At any time gasoline is spilled, the exhaust fans shall be run sufficiently to remove all gasoline fumes. After each fueling and before starting, open the cover of the engine for ventilation to remove gasoline vapor. Diesel engine boats with ventilation fans shall follow the guidelines in this paragraph also.

S9086-TX-STM-010

583-4.4.9 SAFETY INSTRUCTIONS. Safety instructions posted in all gasoline-powered boats shall include the following requirements:

- a. Floorboards immediately adjacent to the engine should be lifted and secured in an open position at all times when the engine is not running if applicable.
- b. The bilges should be inspected for the presence of gasoline and gasoline vapor immediately before each starting of the engine.
- c. Before starting the engine, the engine cover should be lifted exposing the top of the engine for not less than 4 minutes while the bilge exhaust blower is operating, if applicable.
- d. The engine cover should not be closed until after the engine is started and operating satisfactorily.
- e. All fire extinguishers should be in place and charged. In performing the foregoing inspection, special attention should be given to boats that have been out of service for several days or subjected to overhaul. For additional information, refer to NSTM Chapter 233, Diesel Engines, for diesel-powered boats.

583-4.4.10 LIQUEFIED GAS. The use of liquefied gas (propane) for any purpose is prohibited.

583-4.4.11 SIGNAL FLARES. All powered boats should carry distress signals (flares) to be used when conditions warrant.

583-4.4.12 FIRE RESISTANT HOSE. Fire resistant hose is now available for use on Navy boats and craft fuel and lubrication systems. As existing hose needs to be replaced, fire resistant hose should be utilized as follows:

- a. Where hose is used for connections between the engine and fuel service system, within the fuel service system and for engine and transmission lubricating oil service, that hose shall be flexible, fire resistant, compatible with all petroleum products, with brass plated steel wire reinforcement, and shall be suitable for operating pressures up to 400 pounds per square inch. End fittings shall be reusable, flange or swivel, corrosion resistant 316 steel and shall be secured to the hose by threaded wedge action.
- b. The above requirements are known to be met by Aeroquip Corporation FC 234 AQP Hose and Fittings and Stratoflex Corporation 5219 HSP Hose. Additional information regarding hose type identification will be found in the APL for specific boats and craft.

SECTION 5

EQUIPMENT AND REPAIR PARTS

583-5.1 GENERAL.

NAVSEAINST 4790.8B requires implementation of the Maintenance and Material Management (3M) system, in accordance with OPNAVINST 4790.4 Series, for all NAVSEA boat assets with the following exceptions: "Ships, service craft, and small boats manned by civilian crews are also exempted from this instruction unless approved by the Chief of Naval Operations (CNO) as specified in reference (a)." which is OPNAVINST 4790.4 Series.

583-5.1.1 BOAT EQUIPMENT AND OUTFIT. The allowance of equipment required to operate and maintain a given boat, is set forth in the following documents:

- a. Allowance Parts List (APL).
- b. Allowance Equipage List (AEL). APLs or AELs may be requested electronically via the World Wide Web at: [HTTP://www.navicp.navy.mil/apael/index.htm](http://www.navicp.navy.mil/apael/index.htm). If assistance is required to identify applicable APLs or AELs for a specific boat, contact PEO SHIPS PMS 325, or the PMS 325 designated ISEA.

583-5.1.1.1 Boat Equipment. Boat Equipment is defined as systems, equipment or components either permanently installed, or intended to permanently accompany the boat. An example of the latter is the flagstaff. These systems or equipment are referred to as boat equipment, as differentiated from boat equipage or outfit. Logistically significant boat equipment will be either included on, or listed as an accessory item on, the applicable boat APL. In general, logistically significant boat equipment consists of:

- a. Propulsion system and components.
- b. Electrical system and components.
- c. Fendering and collars.
- d. Electronic systems and components (permanently installed).
- e. Dewatering systems and components.
- f. Fuel systems and components.
- g. Fire extinguishing systems (built in).
- h. Steering system and components.
- i. Ventilation systems and components, including ventilation systems for gasoline engine compartment ventilation applications.
- j. Security systems and components.

The types of items listed above will always be issued with and turned in with the boat to which it was originally provided.

S9086-TX-STM-010

583-5.1.1.2 Allowance Parts List (APL). When each boat or group of identical boats under a procurement contract are accepted by the Navy, boat APLs are developed for each boat. The boat APL is characterized by having "72" as its first two characters. This hull registry number specific APL is the primary supply support configuration document for the boat. The boat APL identifies allowances for repair-by-replacement parts and identifies APLs for accessory items. For example, the engine, marine gear, and outdrive will have individual APL numbers. APLs are issued by NAVICP and may be incorporated into an activity's Coordinated Shipboard Allowance List (COSAL) or Coordinated Shore Based Allowance List (COSBAL).

583-5.1.1.3 Outfit Items. Outfit items, also known as equipage for boats is defined as required equipment that is not permanently installed onboard the boat or craft, and may include required safety-related items. Examples of this type of equipment include, but are not limited to:

- a. Ropes
- b. Boat hooks
- c. Fiberglass or inflatable tube repair kits
- d. Starting or other batteries
- e. Anchors
- f. Canopies, canopy bows, covers and cushions (Initial outfit only - Local support thereafter)

583-5.1.1.4 Allowance Equipage List (AEL). The AEL identifies, and lists the allowance of equipage required for safe operation of a given boat. Individual AELs are developed for each boat class, and may be found listed in the Accessory APL portion of the applicable boat APL. Copies of AELs are available from Naval Inventory Control Point (NAVICP), Mechanicsburg PA, or at the URL listed in section [583-5.1.1](#) above.

583-5.1.2 PROCUREMENT OF OUTFIT AND MAINTENANCE PARTS. Although some maintenance parts may be provided with a boat upon initial issue, it is the responsibility of the boat custodian to procure equipage and parts as defined in the activity's COSAL or COSBAL. Outfit and corrective or preventive maintenance parts are to be requisitioned in accordance with NAVSUP P-485, CURRENT EDITION. Although some equipage may be provided with a boat upon initial issue, it is the responsibility of the boat custodian to procure and maintain the equipage identified on the AEL in accordance with Planned Maintenance System requirements, per OPNAVINST 4790.4 Series. NSNs can often be obtained by referring to the applicable APL or AEL in the custodial activity's COSAL or COSBAL. Materials supporting PMS procedures can be found in the Standard PMS Materials Identification Guide (SPMIG).

583-5.5.1.2 Funding. Items of outfit and repair parts for all boats shall be charged as follows:

- a. Ships or service craft being constructed or converted. Charge to funds provided for construction or conversion.
- b. Active ships, naval districts, and naval attaches. Charge to supplies and equipage allotments, Operation and Maintenance Navy, provided to the activity receiving the boat.

583-5-2

- c. Fleet Command Headquarters, Unit Commanders, Type Commanders, and other activities of the operating forces. Charge to funds provided for daily maintenance and operation of the activity receiving the boat.
- d. Military Sealift Command (MSC). Charge to funds cited by MSC.
- e. Shore activities of the Navy. Charge to funds provided by the shore activity receiving the boat.
- f. Activities outside the Navy, including foreign governments. Charge to funds cited to pay for the transfer.

583-5.1.3 DISPOSITION OF OUTFIT AND MAINTENANCE PARTS. All ships, shore activities, and other activities shall dispose of maintenance parts in accordance with NAVSUP P-485. Outfit items shall accompany the boat, unless otherwise specified in the disposition instructions provided by the PMS 325 assigned Boat Inventory Manager (BIM).

583-5.1.4 REPLACEMENT ENGINES. Boat alterations have been issued covering replacement of engines no longer supportable that are installed in active boats. Questions concerning the status of obsolete engines should be directed to NAVSEA PMS 325 assigned ISEA. Engines needed to replace installed units that are beyond economical repair or otherwise unsupportable should be requisitioned via NAVICP according to NAVSUP Pub 4107N and Pub P 485, Afloat Supply Procedures. Questions concerning the status of obsolete engines should be directed to PEO SHIPS PMS 325 or PMS 325 designated ISEA.

PEO SHIPS PMS 325G

1333 Isaac Hull AV, SE Mail Stop 2501

Washington Navy Yard D. C. 20376-2501

SECTION 6

PREVENTION OF COLLISIONS AT SEA

583-6.1 COMMAND RESPONSIBILITY.

The command operating and owning the asset is responsible to conduct all maintenance in accordance with OPNAVINST 4790.4D and applicable PMS program policy and guidance.

583-6.2 NAVIGATION RULES (RULES OF THE ROAD)

583-6.2.1 INTERNATIONAL AND INLAND NAVIGATION RULES. Navigation Rules shall be followed as set forth in U.S. Navy Regulations, Article 1120, Rules for Preventing Collision Comments and information should be addressed to Commandant, U.S. Coast Guard, (G-NSR-3).0

- a. Prevention of collisions is the primary goal of the navigation rules. Navigation lights, day shapes, and sound signaling devices are a major part of the rules, indicating type and size of vessel, the movement of such vessels, the work a vessel is doing and the privileges and responsibilities of vessels.
- b. The adoption of the Inland Navigation Rules Act, 1980 (also referred to as UNIFIED RULES) on the inland waters, western rivers, and the Great Lakes has eliminated much of the confusion that previously existed between the International Regulations for Preventing Collisions at Sea, 1972 (COLREGS) and the U.S. Rules. With the exception of the maneuvering signals and some special rules for the western rivers and the Great Lakes, the rules are now truly uniform.
- c. The COLREGS have been in effect since 1977 and vessels fitted with the lights prescribed by these rules comply with the Inland Rules.
- d. Unless operating exclusively in an area where the Inland Rules apply, vessels must be outfitted with navigation lights required by the COLREGS.
- e. Since January 1, 1983, each self-propelled vessel on inland waters 39.4 feet (12 meters) or more in length must carry onboard and maintain a copy of the INLAND RULES for ready reference.
- f. The penalty provisions of the COLREGS and the INLAND RULES allow for a civil penalty.
- g. For information on the technical details regarding sound signaling devices and the placement of lights, obtain a copy of the U.S. Coast Guard booklet, "Navigation Rules, International-Inland (COMDTINST M16672.2A)" Request stock number 050-012-00-407.2. The COMDTINST are available from the:
Superintendent of Documents
U.S. Government Printing Office
Washington, DC 20402
Or visit website: www.gpoaccess.gov

SECTION 7

HOISTING SLINGS AND FITTINGS

583-7.1 GENERAL REQUIREMENTS.

583-7.1.1 NAVSEA REQUIRED SAFETY FACTORS.

583-7.1.1.1 BOATS AND CRAFT ASSIGNED TO SHIPS. Because of the dynamic nature of boat hoisting loads and the potential for large accelerations, it is the policy of the Naval Sea Systems Command (NAVSEA) to require safety factors as follows for all boats and craft normally assigned as ships' boats to be lifted into shipborne stowages:

- a. All parts shall be designed to a safety factor of at least six, based on the ultimate strength of the material.
- b. All terminating sling shackles shall be Type IVA, class 3 safety anchor shackles, in accordance with RR-C-271D Chains and Attachment, Welded and Weldless. All open sockets terminating a sling leg shall have the pin replaced with a bolt, nut, and cotter pin, similar to a safety anchor shackle pin. Pin material shall be in accordance with RR-S-550D Sockets Wire Rope.
- c. Attachment points shall be on strength members of the boat. d. Design of all slings and attachments shall be approved by PMS 325 before fabrication.

583-7.1.1.2 BOATS AND CRAFT ASSIGNED TO SHORE STATIONS. For boats and craft not designed to be routinely hoisted aboard ship, such as Landing Craft, and those permanently assigned to shore stations, the factors of safety shall be at least five. Such hoisting gear is considered to be logistical only. This category of boats includes extensively reconfigured craft where the specialized nature of the craft, as modified, precludes its being returned to service requiring shipboard hoisting (such as LCM's to diving tenders, work boats, and so forth) as well as other specifically designed craft. In addition:

- a. Attachment points shall be on strength members of the boat.
- b. All terminating sling shackles shall be Type IVA, class 3 safety anchor shackles, in accordance with RR-C-271D. All open sockets terminating a sling leg shall have the pin replaced with a bolt, nut, and cotter pin, similar to a safety anchor shackle pin. Pin material shall be in accordance with RR-S-550D.
- c. Design of all slings and attachments shall be approved by PMS 325 before fabrication.

583-7.1.1.3 HOISTING CONDITION WEIGHTS. The design and testing of all components related to hoisting are based on the design hoisting weight of the boat. The design hoisting weight generally includes hull, machinery (wet), full fuel, full outfit (boat hook, fire extinguishers, etc.), crew, and a growth margin. The design hoisting weight is specified on the hoisting test data plate generally located near the coxswain's station. General information on design hoisting weights is given in Table 583-2-1. Only the weight indicated on the hoisting test data plate shall be used for the baseline weight for determining the overload weight for tests. Should the hoisting test data label plate be missing or illegible, the applicable "Hoisting Arrangement and Details" drawing shall be consulted to determine the correct design hoisting weight. If the drawings do not provide the information, contact the PMS 325 designated ISEA.

S9086-TX-STM-010

583-7.1.1.4 GALVANIZING OF PARTS. Ferrous (i.e., ordinary steel) chain, shackles, sockets, links, rings; equalizing thimbles attached to wire rope, and chains shall be galvanized.

583-7.2 MANUFACTURE OF HOISTING SLINGS, BAILS, AND FITTINGS.

583-7.2.1 TESTING FACILITY. Any repair activity that has the capability of testing slings, bails, hoisting shackles, rods, pins, chain links, and rings is authorized to manufacture such equipment according to applicable drawings, EXCEPT for Aramid fiber (Kevlar) slings which shall not be obtained from any source other than those given on the applicable drawing. Manufacture shall not be accomplished if the equipment is available as a standard stock item. Testing, inspections, marking, and record keeping shall be accomplished in accordance with the further provisions of this section.

CAUTION

Aramid fiber (Kevlar) rope slings require specialized manufacturing process controls to maintain safety standards. Slings shall not be obtained from any source other than those designated on the approved drawings.

583-7.3 INSPECTIONS.

583-7.3.1 GENERAL. All slings, bails, and hoisting fittings shall be visually inspected for proper assembly and condition at least once a month or before each lift and they shall not be used if signs of deterioration are noted. Sockets and shackles shall be checked to ensure the intended pins are used. Before conducting any hoisting test,

a careful inspection shall be made of all hoisting fittings, slings, or bails to determine whether the parts are in proper condition. After any load test, inspect all components for signs of permanent deformation, cracking of any of the components or supporting boat structure, elongated holes, or bent shackle or socket pins.

583-7.3.2 WIRE ROPE SLINGS. Wire rope slings shall be inspected for broken or damaged strands, crimps, kinks, cuts, and corrosion. Inspection and removal shall be in accordance with NSTM Chapter 613.

583-7.3.3 WEBBING SLINGS. Webbing slings shall be inspected for abrasion, tears, cuts, snags, punctures and fraying of the webbing and stitching. Slings exhibiting any of the following shall be removed from service:

- a. Acid or caustic burns
- b. Melting or charring of any part of the sling
- c. Snags, punctures, tears, or cuts
- d. Broken or worn stitches
- e. Distortion of fittings
- f. Wear or elongation exceeding amount recommended by manufacturer
- g. Other apparent defects that cause doubt as to the strength of the sling
- h. Loading of the sling beyond its rated capacity

583-7-2

- i. Exposure of Red Guard warning yarn
- j. Paint present on any part of webbing

Since new webbing exhibits different stretch characteristics from older webbing, the entire sling should be disposed of in lieu of replacing only the bad sling legs. Tying knots in webbing slings will dramatically reduce the strength of the webbing and is not allowed. Paint will also reduce the strength of the webbing and should not be used for stenciling.

583-7.3.4 ARAMID FIBER (KEVLAR) SLINGS. Slings should be inspected for cuts, abrasions, snagging and badly worn areas in the outer jacket. Extensive damage to outer jacket could indicate damage to inner load bearing core. Slings exhibiting any of the following shall be removed from service:

- a. Core has been cut or damaged
- b. Slings have been exposed to excessive heat (greater than 150 degrees Fahrenheit)
- c. Slings have been loaded beyond their rated capacity
- d. Distortion of fittings
- e. Other apparent defects that cause doubt as to the strength of the sling
- f. Abrasions or cuts on the jacket, which prevent the jacket from providing sufficient protection for the core.

Since new Aramid Fiber (Kevlar) rope exhibits different stretch characteristics from older Aramid Fiber (Kevlar) rope the entire sling should be disposed of in lieu of replacing only the bad sling legs. Tying knots in the slings will dramatically reduce the strength of the sling and is not allowed.

583-7.3.5 LIFTING FRAMES, INSPECTION. Lifting frames shall be inspected for cracks, deformation, corrosion, crimping, and loose fasteners. Frames that contain cracks, deformation, corrosion, or crimping shall be taken out of service. Loose fasteners and similar discrepancies shall be corrected before the bail is placed into service.

583-7.3.5.1 LIFTING FRAMES. Lifting frames are used for the rigid inflatable boats used designated for service on an LPD. This frame, connecting hardware, and fasteners shall be inspected monthly and before each use. Inspect for cracks, corrosion, crimping, and deformities. If the lifting frame exhibits any of these conditions, they shall be taken out of service. Loose fasteners and similar discrepancies shall be corrected before the lifting frame is placed in service.

583-7.4 TESTING.

583-7.4.1 HOISTING SLINGS LOAD TESTS. Job orders or contracts for manufacture of boat slings shall require that the sling and associated hardware not permanently attached to the boat be tested as indicated under the heading of "Test Procedures" on the respective "Hoisting Arrangement and Details" drawings. The number for this drawing can usually be found on the hoisting label plate located near the coxswain's station or in the Boat Information Book. Test loads are intended to be 100 percent in excess of the design-working load of the part. Sling tests shall be performed in load testing equipment designed for that purpose. One hundred percent

S9086-TX-STM-010

overload tests are never performed in the boat. Unless specifications call for testing slings in the same configuration as used, one or more legs may be tested at a time using the straight line pull method at 100 percent overload based on the design load for each leg.

583-7.4.1.1 Wire Rope Sling Load Test Periodicity. During normal repair and overhaul availabilities of a ship, all wire rope slings that have not been tested in the preceding 18 months, except those shipped with new boats, shall be retested and marked before issue. Hoisting slings for boats assigned to shore stations shall be subjected to a 100 percent overload test every 24 months.

583-7.4.1.2 Webbing Sling Load Test and Replacement Periodicity. Operators of boats provided with webbing slings shall refer to the applicable Maintenance Index Page (MIP) for the periodicity of testing and replacement.

583-7.4.1.3 Aramid Fiber (Kevlar) Sling Load Test and Replacement Periodicity. Operators of boats provided with Aramid Fiber (Kevlar) slings shall refer to the applicable Maintenance Index Page (MIP) for the periodicity of testing and replacement.

583-7.4.1.4 Retesting of New Slings. The time interval after which the first periodic testing is required for new slings received from stock or shipped with new boats is taken from the date the slings were placed in service as indicated on the in-service tag. If no in-service tag is present, the retesting period is taken from the date on the certification test markings. If no test markings are present, the sling certification shall be assumed out of date and the slings shall be retested.

583-7.4.2 LIFTING FRAME LOAD TESTS. Rigid bails and or lifting frames are similar to other permanently installed hoisting fittings in that they are less prone to wear and damage than wire rope, webbing or Aramid Fiber (Kevlar) slings. Lifting frames shall be load-tested upon completion of a new boat or after any repairs to the bail. The rigid bail and or lifting frames shall be tested by weighting the boat 50 percent in excess of its normal design hoisting weight and lifting it, using the bail, just clear of the water or shop floor for 10 minutes. When conducting the 50 percent overload test, it is absolutely necessary that the correct weight be used. The design hoisting weight is specified on the hoisting test data plate. Only the weight indicated on the hoisting data plate shall be used for the baseline weight for the 50 percent overload test. The added weight shall be distributed, one half forward and one half aft, as near the hoisting fittings as possible, care being taken not to place any significant added weight amidships.

583-7.4.3 HOISTING FITTING LOAD TESTS. Hoisting fittings permanently attached to the boat shall be load-tested upon completion of a new boat or after extensive repairs have been made to a boat in service. The fittings do not require periodic testing. The boat's lifting slings or lifting frame shall be inspected before conducting this test to ensure their adequacy for the test load and to verify that they have been load tested within the required certification period. The boat's hoisting fittings shall be tested by weighting the boat 50 percent in excess of its normal design hoisting weight and lifting it by its hoisting slings or bail just clear of the water or shop floor for 10 minutes. For boats that have fittings for both sling lifting and davit lifting, the overload test shall be conducted for both configurations. When conducting the 50 percent overload test, it is absolutely necessary that the correct weight be used. The design hoisting weight indicated on the hoisting data plate shall be used for the baseline weight for the 50 percent overload test. The added weight shall be distributed, one half forward and one half aft, as near the hoisting fittings as possible, care being taken not to place any significant added weight amidship.

583-7.4.4 FIT TESTS. Before finally accepting newly issued, repaired, or altered hoisting slings or bails, ships shall test them for fit by hoisting the boat using the method that normally will be used in service. The boat shall be lifted by its slings and suspended for at least 10 minutes, just clear of the water, deck, or stowage, to minimize damage in case of failure.

583-7.5 MARKING.

583-7.5.1 GENERAL. Slings are not designed to be interchangeable between different boat types and marks. Due to differences in the details of the design, slings for a given boat are not always suitable for use on all other boats of the same type. For these reasons, identification markings must be placed on all slings. Slings shall not be issued without test markings attached. If unmarked slings are found in stock or if slings or bails have been repaired, they shall be retested and marked. Naval shipyards receiving boats with hoisting slings that are uncertified may use these slings before recertification testing to hoist the boat within the shipyard if the following steps are adhered to:

- a. The sling is verified as having previously been tested to the correct load from the test bands installed on the sling.
- b. The wire rope or webbing and fittings are visually inspected for damage, wear, corrosion, or other defects.
- c. If the above inspections determine that the sling is satisfactory, the boat should be secured to the sling and hoisted just clear of all other support and held for a minimum period of 10 minutes by the sling. The sling is then reinspected for evidence of failure or permanent deformation.

NOTE

Aramid Fiber (Kevlar) slings shall be marked in accordance with the MIP.

583-7.5.2 WIRE ROPE SLINGS. When slings are manufactured and after the load test has been satisfactorily completed, a copper or stainless steel band shall be fitted to each sling leg, identifying the leg (for example aft-port), indicating the test has been made and giving the name of the certifying activity, the contract number (if applicable), the registry number of the boat for which manufactured (for example, 26MW9001), the government inspecting office (if applicable), and the date of the test. If the sling is being returned to service after periodic testing, the bands shall be marked with the test date and name of the testing activity. If, for any reason, slings are assigned to another boat of like design (type and mark), the boat number on the band shall be changed accordingly.

583-7.5.3 WEBBING SLINGS. When slings are manufactured and after the load test has been satisfactorily completed, an etched leather tag shall be sewn to each sling leg, identifying the leg (for example aft-port), indicating the test has been made and giving the name of the certifying activity, the contract number (if applicable), the registry number of the boat for which manufactured (for example, 24RB9101), the government inspecting office (if applicable), and the date of the test. If the sling is being returned to service after periodic testing, the tags shall be marked with the test date and name of the testing activity. If, for any reason, slings are assigned to another boat of like design (type and mark), the boat number on the tag shall be changed accordingly.

583-7.5.4 LIFTING FITTINGS. New boats shall be delivered with a hoisting test data label plate which identifies the design hoisting weight of the boat, the weight of the boat for the 50 percent overload test. Repair activi-

S9086-TX-STM-010

ties shall update the hoisting test data label plate by stamping or engraving the data and activity certifying subsequent overload tests of the boat's lifting fittings. If there is no hoisting test data label plate, a new label plate may be fabricated in accordance with the applicable "Hoisting Arrangement and Details" drawing and installed in the vicinity of the coxswain's station. This includes the lifting frame.

583-7.5.5 IN-SERVICE TAGS. Slings shipped with new boats or received from stock should be marked by the receiving activity to indicate the date the slings are actually put into service. This is done to avoid unnecessary retesting when new slings, which were load tested during manufacture, have been kept in storage before issue. The date placed in service should be engraved or punched on the in-service tag provided with the sling. If no tag is provided, an in-service tag may be fabricated by the receiving activity and attached to the lifting ring in a manner that does not interfere with any of the working surfaces of the sling. The in-service tag should indicate the date placed in service and the activity placing the sling in service. The original load test tag shall not be removed. The in-service date is the date the sling is placed on a boat aboard ship or begins use by a shore facility. For new ship construction service begins when the slings are first used for handling the boat after delivery to the shipbuilder.

583-7.6 RECORDS OF INSPECTION AND TESTS.

583-7.6.1 CRAFT LOG. Boat operators or the ship's force concerned shall maintain a record of inspections and test of hoisting fittings, lifting frames, shackles, rings, and slings. Records shall show the date, and shall describe the condition of the parts inspected and tested. These records shall be kept as a part of the normal craft log.

583-7.6.2 REPAIR ACTIVITIES' RECORD OF INSPECTIONS AND TESTS. Repair activities shall keep a record of inspections and tests of hoisting fittings, rigid bails, shackles, rings, and slings. Records shall show the date and boat registry number, and shall describe the condition of the parts inspected and tested. Results of these inspections and tests shall be entered in the material history of the boat by the ship or other cognizant activity concerned.

583-7.7 SIDE GUYS.

583-7.7.1 GENERAL. Side guys (steading lines for slings) are required on certain boats where the hoisting fittings are below the center of gravity. Their purpose is to prevent the boat from rolling to one side while being hoisted. Wire rope shall not be used. These guys are not intended to take any part of the weight of the boat in lifting; therefore, no separate load test is required. However, side guys shall be properly installed prior to conducting overload tests on the boat's hoisting fittings.

583-7.7.2 RIGGING FIBER LINE SIDE GUYS. The following procedure should be used in rigging side guys:

- a. Secure a fiber guy to each padeye or cleat intended for its use.
- b. While the boat is onboard ship, take a strain on the slings, adjust length of side guys so that they will not take the hoisting strain.
- c. Secure side guy with a rolling hitch backed up by a half hitch and marry the better end of each side guy to the standing part with a length of marlin.

SECTION 8 MAINTENANCE

583-8.1 INTRODUCTION.

583-8.1.1 PLANNED MAINTENANCE SYSTEM. here the Planned Maintenance System (PMS) is installed, conduct preventive maintenance according to the applicable Maintenance Index Page (MIP) and Maintenance Requirement Cards (MRCs).

583-8.1.1.1 Maintenance Support Documentation. Technical manuals from the manufacturer and the U.S. Navy should be used to support the performance of all maintenance. In the event of conflicting procedures, PMS MRC instructions take precedence.

583-8.1.1.2 Camouflage Paint Requirements. Boats carried on the exterior of the ship must be painted in accordance with NAVSEA Technical Manual S630-AG-MAN-010, Camouflage Manual for Surface Ship Concealment, section 2.3.2.9. Currently boat bottoms are painted black and the recommended concealment color is ocean gray. Hardware and glossy boat surfaces will be painted in accordance with section 2.3.2.2 of TM S630-AG-MAN-010. Hardware or equipment that cannot be painted will be covered by gray canvas while underway. It is recommended that visual inspections be performed often to ensure that moisture damage does not become an issue. The new painting standards for surface ships and their small boats will be provided in MIL-PRF-24267 "Paint System, Anticorrosive and Antifouling Ship Hulls" and in revisions of NSTM Chapter 631.

583-8.2 WOOD BOATS.

Maintenance for wooden boats should performed IAW the applicable MIP and MRCs. Specific concerns or issues should be addressed to the In Service Engineering Agency.

NOTE

Insist on good housekeeping at all times.

583-8.3 ALUMINUM BOATS.

583-8.3.1 GENERAL. Special requirements for maintaining aluminum boats are described in the following paragraphs:

583-8.3.2 ALLOYS. From a wide range of aluminum alloys available for many purposes, the U.S. Navy has selected those most suitable for naval use. The hulls of many naval aluminum boats are constructed of either alloy 5086-H32 or 5456-H321. Hulls of new aluminum boats are constructed with alloys 5086-H116 or H117 or 5456H116 or H117. Alloys with these two tempers should also be used for replacement plates. Refer to paragraph [583-8.3.2.2](#) for clarification of the terms alloy and temper. Both alloys contain magnesium as the primary alloying ingredient but differ slightly in strength. These two alloys are not used in combination except when emergency repairs are needed.

583-8.3.2.1 General Purpose and Other Alloys. Alloy 6061 is a general-purpose structure alloy using a combination of magnesium and silicon as the chief alloying ingredients. Its use in the Navy should be restricted to aux-

S9086-TX-STM-010

iliary systems such as piping, railings, and non-welded structures. Two other alloys that may be found in limited quantities are 5083 and 7039. These are used only for armor and are supplied especially for that purpose. They should not be utilized for other structural areas of an aluminum boat.

583-8.3.2.2 Tempers. Aluminum alloys are not identifiable by appearance and are usually appropriately marked with alloy and temper designations. The temper designation follows the alloy number and indicates the degree of tempering. Tempering is done in two ways depending on the alloy, either by strain hardening or by heat treatment process. An alloy that has been strain hardened has a designator consisting of the letter H and a number, while an alloy that has been heat treated has a designator consisting of T and a number. Thus, a plate labeled 5086-H116 has been strain hardened while one marked 6061-T6 has been heat-treated. Any alloy will be one or the other. For example, all the tempers of 5086 begin with H. The exception is when aluminum is in the soft or annealed condition, which is indicated by suffix 0. Both 5086-0 and 6061-0 and others are available. The temper of material is of concern to the repairman since it is desirable to make replacement of damaged areas with the same alloy and the proper temper.

583-8.3.2.3 General Characteristics. Aluminum is a lightweight material. It is for this reason that it is used for boats and craft. It is strong, weldable, and has excellent general corrosion resistance when proper marine alloys are employed. In the past, most interior spaces of naval boats were left unpainted in aluminum construction. There are some precautions in the handling of aluminum, however, that shall be observed if the full corrosion resistance capability of aluminum is to be achieved. As with many materials, although mild acidic solutions cause slight damage, it is necessary to avoid caustic solutions of any sort, such as sodium hydroxide, sodium carbonate, or sodium phosphate as they cause severe etching of the aluminum, possibly resulting in perforation. CAUTION Stringent precautions shall be taken in the case of mercury. The presence of mercury, even in small amounts, causes severe corrosive attack and under no circumstances are the two metals to be permitted to come in contact with each other. By observing these precautions, routine maintenance can be kept to a minimum.

583-8.3.2.3.1 Galvanic Corrosion. Galvanic corrosion caused by dissimilar metal contact with aluminum is a problem that can occur. In marine applications, aluminum and its alloys are frequently the anodic metal and could corrode in preference to most other common contacting metals except zinc and magnesium. For galvanic corrosion to occur, the following conditions must be satisfied:

- a. A cell shall be present, consisting of at least two metals having different solution potentials and in electrical contact with each other (no matter how indirect).
- b. A conductive medium (electrolyte) is present between the metals.

583-8.3.2.3.2 Galvanic Corrosion Locations. Galvanic corrosion normally occurs with different metals, while crevice corrosion (an other form of galvanic action produced by ion concentration) can take place with improper joint design involving different members of the same alloy. In addition, the metallic compounds in a copper bearing or mercury bearing antifouling paint applied to an aluminum hull can result in a galvanic type of attack. Antifouling paints currently specified for aluminum boats do not contain copper or mercury. It is important to recognize that the amount of corrosion resulting from galvanic action is not a criterion of the metal's inherent resistance to corrosion. The extent of galvanic corrosion will vary greatly with the type of dissimilar metals involved and the nature of the corrosive environment. For example, the rate of galvanic corrosion in atmospheric exposures is far less than that under immersed conditions because of the substantial absence of an electrolyte or its low conductance when present. In immersed conditions, particularly in seawater, a strong electrolyte is present

continuously and serious galvanic corrosion can result. For this reason, the use of dissimilar metals below the exterior and interior water line shall be avoided. Three applications account for most galvanic corrosion situations:

- a. Connections of aluminum deck house bulkheads to a steel boundary bar.
- b. Attachment of steel or brass fittings to an aluminum structure.
- c. Dissimilar metal components such as rudders and propellers on an aluminum hull.

583-8.3.2.3.3 Cleanliness. Cleanliness is always important. Dirty, wet bilges or accumulations of dirt and water anywhere, are to be avoided. A freshwater rinse on a regular basis is generally sufficient. Adherent soil and greasy deposits can be removed using cleaners conforming to MIL-C-22230. Painted areas retain a good appearance for a long period. Regular wash down is all that is needed to maintain appearance.

583-8.3.2.4 Metal Working. Cutting aluminum is more like cutting wood than steel. Oxyacetylene flame is not used because aluminum's oxidation resistance and excellent thermal conductivity carries heat away too fast to get a good cut. In repair work, all cutting should be done mechanically using a circular saw, a saber saw, or (in the shop) a band saw equipped with metal cutting blades. Use of a grease stick or lard oil will prolong blade life. Plasma arc cutting equipment is available for high-speed production work but is not needed for repair work. Shearing or punching of strain hardened alloys should be avoided. Forming is done cold or hot. Aluminum does not change color with heat and doesn't glow red as does steel. Excessive heating can cause the metal to anneal to the soft condition or even melt without any warning. Hot forming is done by carefully heating the metal to no more than 450°F. The temperature can be estimated by the use of temperature sensitive crayons. Each crayon is formulated to melt at a different temperature. When the crayon markings on the metal melt, the heat source may be removed at the proper time. NOTE If field repairs are being made and no crayons are available, a small stick of pine may be used. The stick is touched to the metal and when it just begins to char, the metal is hot enough. This method is not suggested where more accurate means are available.

583-8.3.2.4.1 Forming Annealed Alloys. Forming 5086 and 5456 alloys at temperatures in the range of 150 to 400°F may lower resistance to corrosion and stress corrosion, particularly if the stock is being held at these temperatures for prolonged periods. If the starting stock is in the annealed temper, forming at temperatures in excess of 400°F or reannealing after forming at lower temperatures is recommended. The primary advantage to hot forming annealed stock is to reduce the rate of strain hardening.

583-8.3.2.4.2 Forming Strain Hardened Alloys. Forming the foregoing alloys in strain hardened tempers presents a little different problem, since the effects of temperature on mechanical properties as well as corrosion characteristics, shall be considered. A satisfactory compromise is to form in the temperature range of 400 to 450°F. Heating stock to 450°F for 30 minutes results in approximately 5 percent reduction in the tensile and yield strength. Hot forming is beneficial in processing the alloys in question in the strain-hardened tempers.

583-8.3.2.4.3 Reforming Damaged Parts. Formed parts of a boat that have been damaged shall not be reformed using heat. When possible, it is suggested that the damaged part be replaced by new material formed for the job. Distorted plates whether caused by damage or the heat of welding, shall not be straightened by flame quenching (torch heating followed by spray cooling). The method does not work well and can result in overheating or melting as described previously. If the distortion does nothing more than detract from appearance, it should be left alone. Distortion in shapes should be straightened cold, using jacks as necessary. Distortion in plate panels may

S9086-TX-STM-010

be relieved either cold or by making a saw cut in the center of the panel and rewelding it. The normal shrinkage associated with aluminum welding will tend to remove the distortion.

583-8.3.2.4.4 Facilitating Repair. The light weight of aluminum will facilitate repair by making handling easier. In addition, the preparation of subassemblies or repair sections in the shop is greatly facilitated.

583-8.3.3 PAINTING. Aluminum marine alloys under proper care are resistant to salt-water corrosion. In some cases commercial aluminum hull boats have been in saltwater service for several years with the hull left unpainted but with proper cathodic protection. Painting is normally required, however, for satisfactory corrosion resistance. Improperly applied paint systems may cause problems. Corrosion, from any source, will attack at the point of least resistance. It is important therefore, that proper maintenance be given to painted systems. It should also be noted that properly applied paint films have excellent adhesion to aluminum and that problems of spalling, cracking, rust streaks, and chipping, prevalent in steel and wood construction, are greatly minimized with aluminum. Additional information can be found in NSTM Chapter 631.

583-8.3.3.1 Exterior Boottopping and Above. Pitting is the normal overriding factor for routine care and repainting. Chalking, crazing, or blistering are normal signs that repainting is required.

- a. Remove all loose paint by light sandblasting, power brushing, or orbital sanding. Only abrasive impregnated nylon webbing, nonmetallic scouring pads, or abrasive sanding discs (A-A-1016) should be used. Steel wool, wire brushes, or coarse abrasive materials shall not be used. None of these materials should have been previously used on other metals or for removal of copper or mercury pigmented paint before being used on aluminum. The edges of the good paint around the bare areas shall be feathered.
- b. Wash the surface with a liquid detergent (NSN 7930-00-282-9699) and thoroughly rinse with fresh water. The surface should be allowed to dry completely. Painting should take place as soon as practical after cleaning.
- c. Touch up all bare areas with one coat of wash pretreatment coating (formula 117, DOD-P-15328, NSN 8030-00-165-8577). The primer should be applied to a dry film thickness of 0.3 to 0.75 mils. Two coats of either formula 84 zinc chromate alkyd primer (NSN 8010-00-161-7419) or formula 120 zinc chromate primer (MIL-P-15930, NSN 8010-00-753-4714) shall be applied over the pretreatment within 24 hours. Allow a minimum of 8 hours drying time between primer coats and between prime coats and the top coat. Apply two coats of silicone alkyd no. 27 haze gray (NSN 8010-00-917-2256) to a minimum dry film thickness of 1.5 mils per coat.
- d. As an alternative to use of formula 117 and formula 84 or 120, an epoxy system (MIL-DTL 24441) consisting of one coat of formula 150 (NSN 8010-00-410-8452) may be applied to produce a dry film thickness of 3 to 4 mils followed by a coat of formula 151 (NSN 8010-00-410-8458) at a dry film thickness of 3 to 4 mils. The silicone alkyd should be applied before the last coat of epoxy becomes hard (4 to 6 hrs).

583-8.3.3.2 Deck. Areas subject to heavy traffic can be coated with nonskid paint. When recoating is necessary, the following procedure should be used:

- a. Scrape, clean, and apply formula 117 or epoxy formula 150 to bare areas as described in paragraph [583-8.3.3.1](#).
- b. Apply finish coat of MIL-D-23003, type II or MIL-D-24483, type I, 30 mils thick.

583-8-4

583-8.3.3.2.1 Magnesium Castings. Castings of magnesium alloy, if onboard, should be painted as follows:

a. Prepare surface for painting by the dichromite treatment, type III, according to MIL-M-3171. b. Apply two coats of MIL-P-23377 epoxy polyamide primer coating (NSN 8010-01-082-2450), each coat to a minimum dry film thickness of 1 mil. c. Apply two coats of MIL-C-22750 (NSN 8010-00-896-1980) epoxy, each coat to a minimum dry film thickness of 1 mil (total dry film thickness of primer and topcoat shall be 4 mils minimum). d. MIL-P-23377 (NSN8010-01-082-2450) and MIL-C-22750 (NSN 8010-00-896-1980) shall be applied according to manufacturer's instructions.

583-8.3.3.3 Underwater Hull on Boats That Require an Antifouling Coating System. The underwater hull should only be coated with an approved non-copper bearing antifouling system as directed by NAVSEA. Direct application of copper antifouling will severely damage the aluminum hull plating. Antifouling materials used in aluminum underwater hull coating systems are toxic. Personnel engaged in the application of antifouling coatings are cautioned to follow all safety procedures specified for the application of this material by the paint manufacturer and appropriate Maintenance Requirement Cards (MRC). Additional information can be found in NSTM Chapter 631.

583-8.3.3.3.1 Preparation. Before application of any coatings to the underwater hull, the entire area shall be scraped with wood or plastic scraper (exercising care not to gouge the aluminum), freed of fouling, and washed down with fresh water. All deteriorated paint shall be removed and corroded areas shall be sanded, primed, and the anticorrosion coats shall be built up before the application of the antifouling paint, if required.

583-8.3.3.3.2 Application. The successful application of coatings on aluminum requires special attention to some details of surface preparation and application. The procedure shall include the following:

- a. All possible metal fabrication or repair should be accomplished before the surface preparation procedure.
- b. No coatings will be permitted to be applied over metal splinters, delaminated areas, corrosion products, oil, grit, or other foreign matter. All sand will be removed from surfaces by brush or air-blast before applying first coat.
- c. All welded areas or weld splash, either old or new, shall be given special attention. All rough welds, cutoffs, splash, and so forth, shall be removed by disc sanding or chipping.
- d. All new surfaces to be coated shall be dry sand swept.
- e. All surfaces to be coated shall be free of all grease or oil before the use of any abrasive or the application of refresher coats. Grease and oil should be removed with a detergent and thoroughly rinsed with fresh water.
- f. Compressed air used for nozzle blasting shall be free of detrimental amounts of oil or water. Adequate separators or traps shall be provided and these shall be kept emptied of water and oil.
- g. The grit size shall be 40 to 60-mesh glass abrasive. The maximum particle size shall not be larger than that passing through a 40-mesh screen, U.S. sieve size. Local sand will meet this requirement. Do not reuse sand.
- h. Sand sweeping shall be permitted only during daylight hours and on surfaces that will not be wet after blasting or before painting. The only exception to this will be for rough, initial sand sweeping which will be allowed during the night, providing the surface shall be swept clean and bright the next morning with fresh, light sandblasting to provide a contamination free, sand swept surface. Sand sweeping is permissible under an enclosed shelter at anytime providing the surface remains dry.

S9086-TX-STM-010

- i. Sand sweeping is the technique whereby the surface is blasted, at a 60 degrees angle with 40 to 60-mesh sand. This is done lightly and thereby removes only paint and none of the surface metal.
- j. The sand swept surface should be covered by the initial coating of the paint system before any visible or detrimental oxidation (aluminum hydroxide) occurs. When enclosed in a shelter, application of the initial coating can be delayed but shall be applied before detrimental oxidation occurs.
- k. Observe carefully the paint manufacturer's instructions on shelf life, pot life, drying time, and cure time for each coat.

583-8.3.3.4 Bilges. Remove all grease, oil, and other contaminants with a solution of cleaning compound conforming to MIL-C-22230 (NSN 6850-00-965-2359). The solution should be agitated and then all residue flushed with hot fresh water.

- a. Remove corrosion products by mechanical means (nonmetallic brushing, light disc sanding, or hand sanding with a fine grit paper). Surfaces shall be clean and dry before painting.
- b. After thorough cleaning, apply one coat of pretreatment primer, formula 117, DOD-P-15328, NSN 8030-00-165-8577) to 0.5 mils dry film thickness followed by two coats of MIL-P-23377 (NSN 8010-01-082-2450) to 2 mils dry film thickness. This shall be topcoated with one coat of MIL-C-22750 (NSN 8010-00-896-1980) to 3 mils dry film thickness.
- c. As an alternate to the foregoing system, an epoxy system according to class 1 of MIL-P-23236 may be applied over the clean metal surfaces. Application shall be according to manufacturer's instructions.

583-8.3.3.5 Tank Cleaning and Maintenance. The freshwater system shall be thoroughly cleaned and disinfected in accordance with Manual of Naval Medicine, NAVMED P-5010-6. Interiors of aluminum fuel tanks, ballast tanks, bilges and voids need not be painted. Marine Sanitation Device tank interiors shall be painted as follows: One coat MIL-DTL-24441 Formula 150 (NSN 8010-00-410-8452) 3 to 4 mils dry film thickness. One coat MIL-DTL-24441 Formula 151 (NSN 8010-00-410-8458) 2 to 3 mils dry film thickness. One coat MIL-DTL-24441 Formula 156 (NSN 8010-01-350-4745) 2 to 3 mils dry film thickness. One coat MIL-DTL-24441 Formula 157 (NSN 8010-00-410-8461) 2 to 3 mils dry film thickness. Coat interior of lubricating oil tank with lubricating oil preservative, MIL-PRF-3150 (NSN 9150-00-231-2356) medium.

583-8.3.4 CATHODIC PROTECTION. Most aluminum boats are equipped with sacrificial anodes to offset adverse effects of dissimilar metal connections, stray electrical currents, improper grounding, and other sources of electrolytic corrosion. These anodes provide a continuous flow of protective current to corrosion susceptible areas but are sacrificed in doing so. In addition to external hull anode protection, some installations contain anodes that are provided for protection in bilge areas, ballast tanks, sea chests, and overboard discharges.

583-8.3.4.1 Anodes. Certified pure zinc anodes are installed on boats to provide cathodic protection. Aluminum and magnesium anodes may be used on some applications such as outdrives or outboard engines, but are not authorized for use on U.S. Navy boat hulls. Anodes shall be replaced in accordance with PMS instructions. If sufficient anode material, as defined by applicable PMS inspections procedures remains to provide protection until the Planned Maintenance anode inspection and/or replacement, or the next scheduled overhaul, the anode should be retained but the active surface should be power brushed to remove any calcareous buildup and improve the anode output. All coatings or plastic wrappings on anodes shall be removed.

583-8.3.4.2 Depleted Anodes. All depleted anodes shall be replaced with certified 100 percent pure zinc anodes only. If magnesium or aluminum anodes are identified on non-standard or standard U.S. Navy boats, they will be

replaced in accordance with paragraph 583-8.3.4.3. Magnesium anodes are highly active chemically with a large electrical potential difference. Alkaline conditions can be generated which will attack aluminum hull welds and plating. Aluminum anodes frequently become inoperative after installation.

CAUTION

Magnesium and aluminum anodes shall not be used on aluminum hulls.

- a. Corrosion protection of the hull and components, in addition to painting, is provided by type ZHS or ZHC (6-inches by 12-inches by 1-1/4-inches) zinc anodes.
 1. ZTS type anodes shall be used for small boats in place of ZHC or ZHS anodes if three or less ZHC or ZHS anodes are required.
 2. On small boat hulls, use four ZTS anodes in place of a ZHC or ZHS anode.
 3. Where three or less anodes are required, and the anodes must be kept out of the hull bottom water flow, ZHC or ZHS type anodes shall be mounted on the transom. More uniform protection can be attained with a wider distribution of anodes.
- b. Where practical, calculate the quantity of hull anodes required by using the requirements of steel hull ships (NSTM Chapter 633, Cathodic Protection). If impractical, contact NAVSEA.
- c. In addition to the hull anodes, one ZTS anode shall be provided for each 5 square feet, or proportion thereof, for each sea chest or area of dissimilar metals. Waster pieces shall be inspected at each overhaul and replaced, if necessary, with a new waster piece of the same alloy.
- d. Internal bilge areas normally wet shall be protected by 1 square foot of zinc surface for each 200 square feet of coated surface or 50 square feet of bare metal. Anodes of type ZHC, ZSS, or ZEP shall be used as best meet the requirements of the area to be protected.

583-8.3.4.3 Installation. The following instructions provide the necessary supplementation to Naval Sea Systems Command Drawing 805-921865 for installation of zinc anodes on aluminum hull boats. CAUTION Anode faces shall not be coated or covered in any manner except for masking while painting adjacent surface or as noted in paragraph 583-8.3.4.1.

- a. All anodes shall be installed directly on the hull, over the hull coating, and attached with aluminum studs welded to the hull and CRES locknuts. To eliminate binding between the nuts and studs, use an acceptable antiseize compound (a compound consisting of equal parts by weight of petrolatum and zinc dust of 200 mesh fineness may be used).
- b. Where thickness of the hull is not considered adequate to support the attaching studs and anodes, a double plate should be coated with the same paint system as the hull and installed before attaching the anodes.
- c. Where stud installation is not practicable and special brackets have been installed previously to accommodate other anode types, these brackets can be modified to accommodate the recommended installation. If possible, direct installation to this bracket shall be made by drilling the anode straps and bracket for bolt attachment. The anode back (surface nearest the straps) shall be coated similar to the hull. If this cannot be accomplished, a 3/16-inch or similar aluminum plate, with holes or studs to accommodate the desired anode type shall be installed. The recommended anode (s) shall then be attached to this plate according to this instruction.

S9086-TX-STM-010

1. Lock washers shall be utilized with all nuts; electrical continuity between anode and hull shall be maintained.
 2. The plate shall be completely coated with the hull anticorrosive coating system.
 3. Where bolting is required on this installation, stainless steel nuts, lock washers, and bolts shall be used and coated similar to the hull.
- d. ZTS anodes can be modified for stud attachment by drilling a 3/8-inch hole centered 1/2 inch from each core end.
1. An 11-inch center-to-center stud location is necessary.
 2. Aluminum studs, 1/4-inch minimum diameter should be used.
- e. Distribute anodes about the hull similar to steel hull ships (see NSTM Chapter 631), one-third in the stern area, and the remaining anodes equally divided port and starboard approximately amidships.
1. ZHS and ZHC anodes shall be bolted with the long axis fore and aft. 2. ZTS type anodes shall be bolted with the long axis fore and aft.
- f. Anodes shall not be installed in locations interfering with the operation of struts, propellers, propeller shafts, or rudders. Installation in paths of high velocity waterflow should be avoided whenever possible.
1. Anodes shall be installed in the vicinity of dissimilar metal junctions.
 2. Anodes shall be installed in locations always submerged (light ship condition) while the ship is not moving.
- g. On aluminum high-speed boats in which the bow rises from the water, anodes shall be installed in areas that rise out of the main flow. Anodes shall be installed so that they are submerged when the boat is moored.
- h. Internal bilge anodes shall be installed in locations where the anode is submerged whenever water is present, generally near the bilge pump input. A zinc anode shall be installed in each area where water is held or trapped. All stringers shall be provided drain holes (large enough to avoid clogging) that drain into the immediate keel area

583-8.3.5 PIPING SYSTEMS. Due to certain service conditions a wide variety of piping materials are used aboard aluminum craft. In general, complete systems of aluminum or PVC piping in proper service pose no problem. Attention should be given to all dissimilar metal systems.

583-8.3.5.1 Joint Corrosion. Due to availability, specifications, and service intended, valves and fittings in aluminum lines may be of other than aluminum alloy. These joints present a potential site for corrosion and should be checked periodically for corrosion damage and replaced when they will not last until the next overhaul.

583-8.3.5.2 Seacocks. Seacocks are usually bronze or aluminum. If bronze, they will be fitted to the hull with some type of insulation such as neoprene gaskets and PVC ferrules and should be checked periodically for their integrity. If an insulation pad is used, it should be checked for signs of crazing or cracking. Some systems may incorporate a waster piece or an anode as part of the seacock installation. It should be routinely checked and replaced when necessary.

583-8.3.5.3 Lubricating Aluminum Fittings. Aluminum body valves should be checked periodically for signs of freezing. Some assemblies use aluminum-to-aluminum moving parts which can gall. Where possible, moving aluminum parts should be lubricated or replaced with a compatible metal. Some aluminum fittings and valves may require periodic breakdown for inspection, replacement of anodic waster pieces, rerouting systems, and so forth. It is important that all aluminum fittings be reassembled with an approved thread lubricant. A mixture of

50 percent zinc dust in 50 percent mica flour in silicone grease or molybdenum disulfide is a suitable vehicle which will perform an antiseize function. The viscosity of the compound is such that it remains within the joint and forms a tight seal. It should also be non-hardening to facilitate disassembly. The product should be free of lead, tin, or graphite.

583-8.3.5.4 Pipe Hangers. Aluminum piping systems are normally supported by aluminum hangers and brackets and should pose no particular problem. If installed in areas such as ballast tanks, bilges, void spaces, and other areas of high humidity or contaminant concentrations, the hangers should be checked periodically for signs of crevice corrosion of the pipe under the hanger clamp. Some systems may be installed with a layer of rubber or fiberglass tape surrounding the pipe before being fastened to the hanger. Such installations minimize vibration with a subsequent reduction in sound levels. These should be checked for corrosion.

583-8.3.5.4.1 Insulating Dissimilar Metal Lines. All dissimilar metal lines are normally required to be fully insulated from the aluminum structure. This can be done by the application of rubber sleeves, rubber tape, fiberglass tape, or other dielectric. The insulation should extend a minimum of 1/2 inch on either side of the hanger support.

583-8.3.5.4.2 Steel Hangers. If steel hangers are used, then the point of attachment to the aluminum structure should be insulated. Insulation can be accomplished with a dielectric pad and a suitable bolting arrangement.

583-8.3.5.5 Bulkhead Penetration. Aluminum systems will penetrate non-watertight bulkheads through an oversized hole or large cutout for a group of pipes. These areas should be checked for chaffing or other signs of excessive wear to the pipe.

583-8.3.5.5.1 Watertight Bulkheads. Aluminum piping systems will penetrate watertight bulkheads normally through some type of stuffing box arrangement, a proprietary bulkhead penetrator, or through an oversized welded flanged spool piece connected directly to the bulkhead. The connection should be checked for signs of loosening or for possible leakage.

583-8.3.5.5.2 Dissimilar Metal Piping System. Dissimilar metal piping systems will penetrate non-watertight bulkheads either through an oversize hole or through an aluminum spool piece filled with a suitable insulating, resilient product. Such connections also tend to dampen vibrations and reduce sound levels. All dissimilar metal piping systems will penetrate watertight aluminum bulkheads through a stuffing box arrangement. Some of these systems are proprietary and others are fabricated by the shipyard. In each instance, care should be taken to see that the dissimilar metal line does not contact the aluminum structure at any point and that the packing is maintained in sound condition.

583-8.3.5.6 Pipe Insulation. Thermal insulation is generally installed over hot water and exhaust lines. Although several types of insulation meet the requirements of MIL-STD-769, all are not suitable for aluminum lines. Insulation materials containing asbestos shall not be used. Preformed glass, MIL-PRF-22344, Insulation, Pipe Thermal is recommended. The use of calcium silicate may result in some external pipe corrosion if the insulation gets damp. The adhesive (MIL-A-3316C, class II) used for attaching fire resistant thermal insulation to such components as exhaust pipes is corrosive to aluminum. A cloth should be placed in the bilges when this adhesive is being used. Any dripping not caught on the cloth shall be wiped up immediately.

583-8.3.6 MACHINERY, SHAFTING, AND PROPELLERS. Some engine installations are directly mounted to the aluminum foundation with fitted bolts and shims to maintain alignment. Such systems are subject to galvanic

S9086-TX-STM-010

action due to the combination of engine, shafting, propellers, seawater, and the aluminum hull. Installations of this type should be broken electrically by the use of either a flexible coupling or by an insulated flange coupling. The details of this coupling will vary with the craft.

583-8.3.6.1 Shock Mounting. Some installations mount the engine on shock mounts. Shock mounting tends to reduce vibration and serves as an effective method of insulating the engine's dissimilar metal mass from the aluminum hull.

583-8.3.6.2 Stuffing Boxes. Stuffing boxes are generally of bronze construction attached to the shaft log by a heavy-duty rubber hose. Some boats and craft use a specially fabricated aluminum stuffing box. In both cases, the packing is generally, a graphite-impregnated flax. Depending on the combination of stuffing box material, packing, and shaft material, corrosion may occur either on the shaft or in the stuffing box.

583-8.3.6.3 Shaft Logs. Shaft logs are generally heavy wall aluminum tubing.

583-8.3.6.3.1 Inspection. Frequently they will be of an alloy different from the basic hull structure. Because of the possible dissimilarity of weld metals, visual inspection should be made of the welds attaching the log to the hull. If the shaft is pulled, the interior of the shaft log should be inspected for corrosion, scouring, and so forth.

583-8.3.6.3.2 Shaft Buildup. In cases where a shaft has excessive scoring in way of the shaft strut bearings and shaft log seals, the deteriorated or worn area can be refurbished by a thermal spray process. After the worn areas have been machined to sound metal, the spray process applied according to MIL-STD-1687 (Thermal Spray Processes for Naval Ship Machinery and Ordnance Applications) can be used to build up the shaft to the required diameter. The buildup process does not replace the strength of the removed metal; therefore, the shaft shall not be machined below minimum diameter requirements.

583-8.3.6.3.3 Plasma Spray Heating Process. The plasma spray heating process fuses a ceramic coating (87 percent alumina/13 percent titania composite powder 30 + 15 micron mesh size) over a similarly fused bond coat (5.5 percent nickel, 5 percent molybdenum, balance nickel composite powder) applied first to fill the undercut area, after which the final ceramic coating is applied. The ceramic coating, which is limited to .015 inch thick, results in an exceptionally hard surface that will extend the wear properties of the shaft in the area of bearing surfaces. The plasma spraying process can only be utilized using a Navy qualified procedure and operator.

583-8.3.6.4 Propeller Shafting. Propeller shafts are generally stainless steel or monel. If replacement is necessary, they should be replaced with equal type material. When pulled, the area within the shaft log and stuffing box should be inspected.

583-8.3.6.5 Shaft Bearings. Most shaft bearings are of a grooved synthetic rubber bonded to sleeves of either brass, bronze, or fibrous materials. The fibrous material sleeve bearings are recommended as a replacement. The bearing should be equal to Byron Jackson Byplex, that is, the fibrous material conforming to MIL-P-18324 and the rubber conforming to MIL-B-17901. If brass or bronze sleeves are used, a periodic inspection should be made of the installation. If corrosion is occurring between the shell and the strut barrel, they are to be replaced with the Byplex product.

583-8.3.7 TANKS. The following paragraphs apply:

583-8-10

583-8.3.7.1 Freshwater Tanks. Potable water tanks may be integral or of independent construction. Independent tanks may be of monel or stainless steel construction. These tanks will be attached to the hull by straps, brackets, or clips. The installation should be insulated for optimum performance. In some instances smaller dissimilar metal compression tanks will feed off an integral aluminum fresh water tank. The connection between the aluminum tank and the dissimilar metal tank should be insulated and should be checked periodically.

583-8.3.7.2 Fuel Tanks. Annually, fuel tanks should be completely drained and all low points checked for signs of corrosion due to entrapped water condensate.

583-8.3.7.3 Collection Holding Tanks (CHT). Collecting and holding of all onboard waste of human origin from water closet and urinal equipped boats shall be provided. Shore connection for discharging holding tank contents shall be provided. Holding tanks shall be non-corrosive materials and of watertight construction. Internal surfaces shall be free of obstructions to prevent pocketing of sewage.

583-8.3.8 MOORING AND TOWING DECK FITTINGS. Most aluminum naval craft have aluminum mooring and towing fittings. These are welded directly to an aluminum doubler pad or insert plate. Fittings and weld areas should be inspected periodically for beginning signs of cracking or other failures due to overload conditions.

583-8.3.8.1 Dissimilar Metal Fittings. If dissimilar metal fittings are used, they will be bolted through the deck. The bolting arrangement should consist of insulated bolts and insulation of the fitting base from the deck. If such a system has been installed, care should be taken to maintain the sealing bead around the outside of the fitting. A polysulfide product can be formed into a fillet around the outside to prevent seawater from seeping beneath the fitting.

583-8.3.9 DECK EQUIPMENT AND MACHINERY. Deck equipment, machinery, and other miscellaneous gear will normally be attached to the aluminum hull by bolting. Faying surfaces between these dissimilar metals will be insulated according to various Navy systems. Insulation shall be maintained for optimum performance and can be kept maintenance free by periodic checkups.

583-8.3.9.1 Deck Equipment Reinstallation. If it is necessary to remove a piece of deck equipment, care should be taken to reinstall it with proper insulation. If gasketing material is used between the faying flanges, it should be replaced with a similar kind. Under no circumstances should red lead, canvas, or any other wicking type material be used as an insulation gasket. Synthetic rubber is acceptable; the material selected, however, should not be subject to cold flow, cracking, or creeping. A new gasket should be used whenever possible.

583-8.3.10 ADDITIONAL REQUIREMENTS. Additional requirements for maintenance of aluminum boats are contained in the following paragraphs:

CAUTION

The nature of aluminum hull boats merits special attention for mooring location, particularly next to steel ships, buoys, and piers. Under these conditions, it is essential that non-conducting mooring lines be used, as well as

S9086-TX-STM-010

Caution - precedes

insulating camel sections, to prevent electrical contact of the aluminum hull with a steel structure, since this could result in galvanic corrosion of the aluminum hull.

583-8.3.10.1 Mooring. Since aluminum is more electrochemically active than other materials of construction used in marine hulls, it is necessary to avoid direct metal coupling of aluminum hulls to steel hulls, buoys, and docks. For example, when tying aluminum craft to a common buoy to which steel hulled craft are tied, lines or hawsers should be made of a non-conducting material such as nylon or manila hemp. In the event a metallic chain or cable is used, it is essential that there be an insulation line or break in the chain or cable. This can be effected by an insert of a nonmetallic non-conducting segment.

583-8.3.10.2 Shore Power. Shore power should be taken aboard through a 1:1 isolation transformer, which is properly insulated from the boat. The system utilizes the transformer to conductively separate the shore feeder conductors from the electrical load circuits on the boat. The shore-grounding conductor is used to ground the noncurrent carrying parts of the isolation transformer but is conductively separate from the boat ground. The isolation transformer effectively separates the aluminum hull from all other hulls on a common grounding circuit.

583-8.3.10.2.1 With Isolation Transformer. The transformer precludes the possibility of hull corrosion due to a direct grounding bond with all other metal hulls on the common shore power circuit.

583-8.3.10.2.2 Without Isolation Transformer. The use of shore based power without an isolation transformer while moored to other ships, docks, or when in repair yards, to provide electrical current or services to aluminum hull craft, shall be considered with care in order to avoid the possibility of corrosion of the aluminum hull resulting from stray currents [either alternating current (AC) or direct current (DC)]. This is commonly referred to as stray current corrosion or electrolysis.

583-8.3.10.2.3 Electrical Shore Facilities. Other potential causes of electrolysis or stray current corrosion are the electrical shore facilities such as railways and crane tracks. They may cause current discharge from the hulls if they are in metallic contact with these structures.

583-8.13.10.2.4 Gangways and Welding Machines. Gangways with metal runners can be a connecting path. They should be electrically insulated from the hull during docking. The electrolysis corrosion caused by welding and associated operations resulting from improper grounding, can be overcome by proper design in grounding of the welding machines and accessory equipment. These grounds should be as outlined in NSTM Chapter 074, Volume 1, Welding and Allied Processes.

583-8.3.10.2.5 Ground. The hull serves as a ground. This is quite proper, providing return current does not flow either wholly or in part, to a seawater path back to the current source.

583-8.3.10.2.6 Stray Current. Stray current corrosion is most likely to occur when DC electrical equipment is grounded to the hull and is frequently associated with turbo generators, electrical motors, weld generators, and electronic equipment. It shall not be forgotten, however, that AC systems do occasionally carry some DC components and can cause corrosion.

583-8.3.10.2.7 Isolating Welding Sets. All DC cable for welding motor generator sets including resistors should be installed on the craft where the welding is to be done. A welding generator on one craft, grounded to that craft,

shall not be used to perform welding on another craft. If it is not possible to install the welding machine onboard, it should be installed on shore in a location as close as possible to the craft. The generator shall be grounded directly to the craft in which the welding is being done. Care should be taken to ensure that no intermediate contact of the lead and ground cables is made between the generator and the craft. No ground connections shall be made between the craft and the shore or adjacent craft, for welding. Care should be taken to avoid cables hanging or sagging between the craft and shore.

583-8.3.10.2.8 Battery Chargers. Battery chargers shall be located aboard the boat being serviced during the charging operation, or the batteries should be removed and charged on shore.

583-8.3.10.3 Field Attachments. Care shall be taken in attaching metallic or non-metallic components to the aluminum structure. Otherwise, corrosion of the aluminum may occur. Faying (adjoining) surfaces should be covered with protective coatings. Non-conducting materials should be used as an interleave to prevent direct metal-to-metal contact. All depressions and crevices should be filled with suitable caulking compounds.

583-8.3.10.4 Bilge Flush. Bilges and voids should be inspected periodically for signs of corrosion. Periodic fresh water rinsing and cleaning of bilges will minimize heavy concentration of undesirable contaminants. In the absence of freshwater rinsing, clean saltwater rinses are acceptable. The bilges should be pumped dry after rinsing and kept as dry as possible thereafter.

583-8.3.10.5 Cavitation Corrosion. The most common areas where cavitation corrosion may be found are in the vicinity of the shaft, propellers, or other protruding underwater components. Corrosion can be controlled by cathodic protection through the use of zinc anodes. Where such damage is found, corrective actions consist of restoring the damaged metal by welding and grinding, or by replacement of the damaged part and installation of zincs, type ZHC or ZHS (approximately 1 square foot of zinc for every 200 square feet of structural surface); or as an interim measure, the damaged metal may be replaced with an aluminum filled epoxy cement. Use of epoxy shall be recorded in the boat's history cards with a positive requirement that the epoxy be replaced by welding at the first availability.

583-8.3.10.6 Drydocking. Inspection of aluminum boats for corrosion is usually confined to the interior structure, particularly the bilge area, and the underwater outside surface of the hull.

583-8.3.10.6.1 Bilge Area. The bilge areas, unless properly protected and maintained by good housekeeping techniques, may be subject to pitting type corrosion where bilge water and sediment remain in long time contact with the aluminum. In the event corrosion does occur, it will probably be found in the area where the bilge water is retained for the longest time.

583-8.3.10.6.2 Bilge Zinc Anodes. The condition of galvanic anodes used to suppress bilge area corrosion should be checked to assure continued protection by the anodes. Anodes that have been consumed should be replaced with new material, and those not consumed should be cleaned by stainless steel wire brushing at periodic intervals.

583-8.3.10.6.3 Exterior Hull Surface. The exterior surfaces of the hull should be examined to assess the condition of the antifouling paint systems and to look for localized corrosion resulting from galvanic attack between aluminum and non-aluminum components such as those found in the through hull fittings, the bearing housing, and struts for the shaft and propellers. Also check for pitting corrosion on the transom in the vicinity of the

S9086-TX-STM-010

exhaust. Examine all structural welds; especially in the aft bottom area; to confirm there has been no cracking within the welds or in the plate adjacent to the welds as the result of vibration or fatigue.

583-8.4 STEEL BOATS.

583-8.4.1 PAINTING, SAND-BLASTING, AND SCRAPING. Painting and scraping of steel boats shall be done according to NSTM Chapter 631.

583-8.4.2 CATHODIC PROTECTION. Cathodic protection of steel boats shall be done according to paragraph [583-8.6](#).

583-8.4.3 STRAY CURRENT PROTECTION. Welding equipment hook up and grounding connections shall be done according to NSTM Chapter 074, Volume 1.

583-8.5 GLASS REINFORCED PLASTIC BOATS.

583-8.5.1 GLASS REINFORCED PLASTIC BOAT HULLS. Glass Reinforced Plastic (GRP) (also referred to as fiberglass) boat hulls generally require little maintenance other than cosmetic painting, except in cases of severe damage. Maintenance of cathodic protection, if installed, is covered in paragraph [583-8.6.1](#).

583-8.5.2 GLASS REINFORCED PLASTIC BOAT CONSTRUCTION. The following is a brief description of procedures followed in fabricating GRP boats. The majority of the hulls are fabricated in female molds, the interiors of which are sprayed with a gel coat resin before lay-up of the hull commences. This results in a smooth, clear, outer hull surface. To this gel coat, layers of mat and layers of coarsely woven cloth (woven roving) are laid in the mold and impregnated with resin, which if properly laid up will result in a translucent hull. The translucency allows inspectors to check the quality of the lay-up utilizing a light in the far side of the laminate to determine if the layers have been properly impregnated. In some cases, a condition known as white laminate occurs signifying a resin starved area. Small sections of these areas can be removed and corrected.

583-8.5.3 GLASS REINFORCED PLASTIC BOAT CONSTRUCTION TYPES. There is two basic types of construction used in fabricating glass reinforced plastic (GRP) Navy boats: single skin and sandwich. Boats with single skin construction are generally laid up of one ply mat adjacent to the gel coat and varying numbers of woven roving to attain required design hull thickness. Sandwich construction is generally achieved by the use of mat and woven roving skins sufficiently strong and firmly bonded to a thicker, lightweight core such as foam or end grain balsa. This type of construction increases the strength and rigidity of the flat panel without the use of a solid laminate. The bond strength between the GRP skins and core is extremely important to the panel performance. Foam cored girders running the full length of the hull are bonded in to provide longitudinal strength. The hull then cures (resin hardens) in the mold after which it is removed and placed in a supporting cradle for final assembly with its various components. Other parts of the boat such as decks, bulkheads, cabin tops, and engine boxes are molded in a similar manner. Attachment to a partially cured area of plastic using resin is called a primary bond which has a greater final strength than a secondary bond (paragraph [583-8.5.4](#)).

583-8.5.4 CONSTRUCTION BONDING. Decks, bulkheads, and other parts are bonded to the hull with resin-impregnated strips of fiberglass material known as bonding angles. When the bonding is accomplished after the hull has completely hardened or cured the bond is called a secondary bond. Such a bond is capable of strengths of up to 80 percent of that obtained by primary bonds.

583-8.5.5 ATTACHMENT AND SUPPORT OF L OR T SHAPES. The attachment and support of L or T shapes by which the decks, bulkheads, and other parts are attached to the hull using resin, are bonding angles. When these attachment supports are secured to the hull with resin after the hull is completely cured, the attachment is a secondary bond capable of perhaps 80 percent of that attained by primary bonding.

583-8.5.6 PAINT REMOVAL . Old paint coats on plastic boats shall not be removed by use of a blowtorch. Details on painting are contained in applicable Boat Information Books (BIB's) and NSTM Chapter 631. Additional guidance on inspection and maintenance of plastic boats is contained in NAVSEA 0900-LP-006-0010, Reinforced Plastics Preventive Maintenance and Repair Manual for guidance.

583-8.5.7 PREVENTIVE MAINTENANCE. Preventive maintenance for all boats is imperative, particularly for GRP boats, since extensive deterioration can develop if delaminations, punctures, and cracks go uncorrected. For this reason the following guidance applies to GRP boats. Refer to NAVSEA 0900-LP-006-0010 Reinforced Plastics Preventive Maintenance and Repair Manual for guidance on repairs.

583-8.5.7.1 Inspection. GRP hulls are normal smooth and fair. Abnormal indentations, bulges, cracks, or craze marks should be closely examined on both the exterior and interior of the hull, whenever possible, in accordance with PMS procedures.

583-8.5.7.1.1 Bolts and Fasteners. Bolts and fasteners used in some of the older GRP boats were not of corrosion resistant materials and even though they have been sealed may rust or otherwise corrode. Rust formation, for example, will break the secondary bond between the plugs and the cavity wall and force the plugs out.

583-8.5.7.1.2 Defective Fasteners. The plug should be lifted out and the fasteners carefully inspected. The condition of the nuts or locking devices on the inside should be determined. A protective coating should be applied. The cavities at the plug locations may then be temporarily refilled and refinished. In the event that no corrective action can be taken towards the fastenings (if defective), a PMS record shall be made noting the need for the repairs to be accomplished by a qualified activity at the earliest opportunity. Early repair is particularly important if the fasteners are part of the lifting fittings or other systems involving safety.

583-8.5.7.2 Craze Marks. These appear as a group of closed spaced lines usually covering a central area. Occasionally, only the paint will be crazed if applied excessively or buildup is too thick. Generally, however, craze marks indicate the area has been over-stressed by impact or overload damaging the gel coat and inner GRP structure, as at cleats or lifting fittings. Craze marks may also occur at bulkhead attachments to the hull and adjacent to hard spots in areas where impacts will impose severe shear forces.

583-8.15.7.3 Deformation. Fiberglass sections are unable to sustain permanent deformation. Therefore, any metal frames, struts, structures, or girders, that for any reason become deformed under some type of tension, should have their fasteners loosened as soon as possible (if not already torn from the fiberglass) to relieve stresses on the fiberglass and prevent further damage. The stem, gunwales, and transom corners are the areas most susceptible to damage being the outer-most and stiffest areas of the hull.

583-8.5.7.4 Flotation Material. Flotation material is installed in all Navy standard passenger carrying fiberglass boats. Normal installation locations are high up under the gunwales wherever possible throughout. Since these areas are subject to hard shock, inspections of the inner side of the hull are difficult due to the installation of foam. The newest flotation material of closed cell configuration does not normally absorb moisture. However, if subjected to an extreme impact or direct compressive forces, it will crush. Thus, water can be introduced between

S9086-TX-STM-010

the inner and outer shells of the hull and into spaces containing the flotation material. It is imperative therefore, that all gouges, punctures, cracks, and delaminations be sealed as soon as possible after detection to stop entry of water which in large amounts will add significant weight, reducing the safety factor of the lifting fittings. Entry of seawater will introduce marine organisms, which will grow and cause unpleasant odors within the boat. These odors are extremely difficult to eliminate once the organisms permeate the flotation material spaces.

583-8.5.7.5 Loose Fastenings. Fastenings penetrating the GRP structure should be regularly checked for tightness. Loose bolts will result in elongated holes, sheared-off fastener heads, and localized stresses causing cracks, fractures, or delaminations. Fastenings for cleats and handrails are particularly susceptible to loosening and should be checked and tightened regularly. Door hinges, deck plates, cabin fans, and machinery fastenings also have tendencies to work loose and should be checked regularly.

583-8.5.7.6 Propeller, Shaft, and Strut. While the boat is stowed in chocks (not waterborne) the propeller shaft should be checked for nicks, bends, and evidence of erosion, corrosion, or electrolysis. If necessary, the propeller should be removed and repaired or replaced. Work the propeller shaft by hand to check its fit in the strut bearing. If side play is considered to be excessive and causing vibration, the strut bearing should be replaced.

583-8.6 CATHODIC PROTECTION OF BOATS.

583-8.6.1 ZINC ANODES INSTALLATION. Zinc anodes shall be installed on all steel and aluminum boats and on some types of wood or plastic boats having large amounts of electronic equipment installed, such as torpedo retrievers, air rescue boats, and minesweepers. All zinc anodes shall conform to MIL-A-18001, and shall be installed according to NAVSEA dwg 805-921865. Instructions regarding anode quantities and installation are detailed in NSTM, Chapter 633. For aluminum hull boats, refer to paragraphs [583-8.3.4.1](#) through [583-8.3.4.3](#).

583-8.7 ENGINE MAINTENANCE .

583-8.7.1 ENGINE MAINTENANCE. Engines installed in Navy boats must be operated and maintained at the highest practical level to provide maximum reliability, readiness, and efficiency. The diesel engine is the predominant boat propulsion system. Engine maintenance is covered in several publications, which provide complete guidance.

- a. The engine manufacturer's technical manuals
- b. NSTM Chapter 233, Diesel Engines
- c. NSTM Chapter 220 Volume 3, Corrosion and Contamination Control for Diesel Engine Cooling Water Systems
- d. Applicable Boat Information Book
- e. Allowance Parts List, Coordinated Shipboard Allowance List, or activity's allowance

583-8.7.2 ENGINE MAINTENANCE RESPONSIBILITY. Engine maintenance is performed by the activity to which the boat is assigned. Daily maintenance check off by boat crews is of particular importance. Utilize the Planned Maintenance System (PMS) to properly maintain the engine.

583-8.8 GUIDANCE FOR FLEET PERSONNEL ON PREVENTIVE MAINTENANCE AND REPAIR OF BOATS AND LANDING CRAFT.

583-8.8.1 INITIAL INSPECTIONS. On new boats in use, visual inspections should occur frequently during the initial 6 months' use period. As service experience is gained following this use period, periodicity between inspections should follow the PMS card requirements.

583-8.8.2 REFERENCE MATERIAL. Boat crews should reference the Boat Information Book (BIB), applicable U.S. Navy Technical Manuals, commercial technical manuals from the equipment manufacturers, and installed PMS for maintenance scheduling and repair techniques.

SECTION 9

PRESERVATION, STORAGE, AND DEPRESERVATION OF BOATS ASHORE

583-9.1 INTRODUCTION

583-9.1.1 STOCK BOATS. All stock boats, except LCM's, that are in repairable or issuable condition shall be provided with a shelter. It is imperative that there be no delay in affording shelter to repaired and repairable boats, to new boats received for stock, to boats awaiting shipment, or boats being held for ships. Boat shelters shall be of a design approved by PMS 325.

583-9.1.2 REPAIRABLE OR ISSUABLE STOCK BOATS. All repairable or issuable stock boats, their equipment, and machinery shall be prepared for turn-in or storage according to the applicable procedures outlined in paragraphs 583-9.1.4 and 583-9.2.1 through 583-9.2.4. It is essential that there be no delay in accomplishing these procedures once a boat is received for storage. Deviations from the procedures described in this chapter shall not be undertaken without prior PMS 325 approval.

583-9.1.3 REMOVAL OF ENGINES FROM STOCK BOATS. The removal of engines from boats in stock and from boats received for stock shall not be accomplished unless specifically directed by PEO SHIPS PMS 325. The installation of engines in stock boats having unserviceable engines, or in stock boats having engines removed according to previous policy, shall be deferred until such time as the boats are scheduled for repair by PMS 325.

583-9.1.4 STOCK BOATS CHECKOFF LIST. Applicable check off lists outlined in paragraphs 583-9.2.1 through 583-9.2.4 shall be used for each boat placed in storage and for conducting routine and preservation inspections. This check off list shall be used to ascertain whether a boat and the boat components are properly stored, and this should be entered on the boat record card. The boat checklist (Table 583-1-5), a copy of the boat record and a copy of the boat inspection report (NAVSEA 9583/3, Figure 583-1-1) are to be placed in a water-tight clear plastic bag and attached to the top of the engine by the custodian activity turning in the boat. Include available information indicating total operating hours on engine since installation or last major overhaul and all available maintenance record data.

583-9.2 PRESERVATION PROCEDURES

583-9.2.1 CUSTODIAN RESPONSIBILITIES FOR PRESERVATION. It is the responsibility of the custodian activity to comply with procedures for turn-in of boats as outlined in paragraphs 583-1.5.3 and 583-1.5.5 and provisions for preservation as outlined in paragraph 583-9.2. Prior to delivery of a boat to a storage facility, the custodian activity shall ensure the following has been accomplished. Upon receipt of a boat (new or used), the storage facility should check the following items for all boats including wood, steel, aluminum, and fiber-reinforced plastic (FRP) construction:

- a. Fuel tanks, drain tanks, expansion tanks, potable water tanks, and sanitary water tanks are dry or preserved for storage. If applicable, the connection to these tanks shall be broken at the lowest point and the system completely drained. Waterproof tags shall be attached to all broken connections, closed or open valves, filling connections, and to the helm or tiller to indicate the necessity for reconnection or replacement of plugs before filling tanks. Secure openings to fresh water tanks after draining to prevent contamination.

S9086-TX-STM-010

- b. The engine cooling and exhaust system has been drained and the engine and accessory equipment have been preserved. Refer to paragraphs 583-9.2.2 through 583-9.21 for procedures on preserving engines.
- c. Bilges have been cleaned and limber holes and scuppers are unobstructed.
- d. All fittings, piping, shafting, propellers, and bearings have been preserved with a coating of MIL-PRF-16173E, water displacing soft film (NSN 8030-00-244-1296).
- e. All fresh water has been removed from piping, freshwater tanks, engines, pumps, exhausts, and bilges. All drain plugs have been removed and attached in a packet to the steering wheel or tiller. The boat is properly trimmed to facilitate drainage.
- f. Check to be sure batteries have been removed after preservation is completed.
- g. Propellers less than 24 inches in diameter, and those, whose blades protrude beyond the keel line, are removed and stored within the boat. Shaft keys, propeller nuts, cotter pins, and other parts shall be replaced on shaft and secured as necessary. Do not apply contact preservative to rubber. Propellers larger than 24 inches in diameter and not protruding beyond keel line need not be removed from the shafts.
- h. The hull registry number is either molded on the transom or otherwise legibly marked on the hull of the boat. If a hull registry number, which is only painted on the hull, is removed during repairs, it shall be replaced immediately after repairs to that area are completed.
- i. All boats that PEO SHIPS PMS 325 has declared excess or that PEO SHIPS PMS 325 has advised are beyond economical repair, shall be plainly marked with the letter D either on the bow or on the transom. The letter shall be approximately 12 inches high and made with yellow paint. j. All dunnage, lifejackets, and rope shall be removed. All canopies shall be removed, dried and stored separately in a dry secure location on the boat or packaged in water resistance packaging and stored in areas exposed to the weather on the boat.

583-9.2.2 BOAT ENGINE, REVERSE GEAR, AND PROPULSION UNIT PRESERVATION. The instructions for preservation of engine, reverse gear, and propulsion unit shall be accomplished in accordance with the manufacturer recommendations. Manufacturers recommendations are found in the Commercial-Off-the Shelf manuals and data provided with the boat. Additional guidance can be found in appropriate MIP. Preservation methods shall displace dirt, water, and oil, and leave a continuous protective film on surfaces. Excess preservative is to be drained off to prevent the formation of stagnant pools that may, with age, tend to solidify and complicate putting an engine back into service.

583-9.2.2.1 Motoring Engine. If it is feasible to turn the engine over by motoring, the following steps are to be followed:

- a. Thoroughly drain the engine and reduction gear of all water, lubricating oil, and fuel oil. Use forced air to blow-dry seawater and freshwater systems. In addition, completely drain and air-dry the exhaust system.
- b. Remove engine and reduction gear oil cartridge and spin-off type filter elements and clean the interiors of all strainer and filter housings. Install new oil filter elements.
- c. Remove the raw water pump impeller, place in a plastic bag and affix to top of engine. Release tension on all belt-driven devices. Affix caution tag to steering wheel stating belts must be tightened and impeller installed prior to engine start-up.
- d. Flush the engine seawater system with fresh water, air dry, fill the system with soluble oil MIL-I-24453A and circulate throughout the system (soluble oil, Kutwell-40 may be obtained from Convoy Oil Corp. 1412 N. Front St. Philadelphia, PA 19122). Drain the entire system including block.

- e. Fill freshwater system with P10, Grade 30 preservative by connecting a supply line to the drain connection for the system. Cause system to overflow from expansion tank vent to ensure that all surfaces are coated with preservative. Drain the preservative from the system and close drain connections.
- f. Fill the engine and reduction gear lubrication system to normal capacity with P10, Grade 30 preservative.
- g. Blank off air intakes or activate air shutdown valve, if installed, to keep the engine from firing.
- h. Motor engine sufficiently to circulate the preservative through the engine lubrication systems. Several minutes (total time) should be adequate but visual checks should be made to ensure that the compound is reaching all points. If an electrical starting motor is used for turning the engine, runs should be limited to 30 seconds each to prevent overheating the motor, and at least 2 minutes should elapse between runs.
- i. Disconnect the fuel inlet line at the strainer and circulate PE 10 preservative through the strainer, fuel supply pump filter, and injectors until undiluted preservative oil flows from the fuel return line. To lubricate valves, pistons and liners, and combustion chamber surfaces, place the throttle in full fuel position and motor the engine until vaporized oil emerges from the exhaust manifold or riser opening. If an electrical starting motor is used for turning the engine, runs should be limited to 30 seconds each to prevent overheating the starting motor, and at least 2 minutes should elapse between runs.

CAUTION

To prevent possible hydraulic lock, do not exceed 2 minutes of cranking total time.

- j. Drain the preservative oil from all systems, paying particular attention to low spots, pockets, and exposed piping in which the compound could collect. Save drained compound for future use.
- k. Reconnect all lines for normal operation.
- l. Seal all openings into the engine to prevent entrance of dirt or water. A blank metal or other non-porous material plate shall be installed between the exhaust manifold or turbocharger outlet and exhaust hose fitting to prevent moisture from seeping back into the engine. Leave a minimum 1" lip exposed on the blank plate. Install a waterproof tag on the blank plate with a warning stating, "REMOVE BLANK PLATE PRIOR TO STARTING ENGINE OR EQUIPMENT DAMAGE MAY OCCUR. "
- m. Using grade 2 compound, MIL- PRF-16173E, spray or brush over all external unpainted areas. If the engine will be exposed to the weather, grade 1 compound should be used for this purpose. Spray or brush P10, Grade 30 preservative on internal surfaces of mild steel fuel tanks after all fuel and moisture have been removed.
- n. Attach a waterproof tag to the top of the engine indicating that the fluid systems have been treated with preservative, raw water pump impeller removed, drive belts loosened and a blank plate installed in the exhaust outlet. Remove the engine start fuses and tag fuse box and fuses; enclose fuses with startup instructions. The tag shall include the date on which the engine was treated, a statement that the engine is not to be turned over until ready to be put into operation (as turning over may impair the protective film), a statement that the procedure specified in paragraph 583-9.4.3 shall be followed before placing the engine in service, and that the lubrication, cooling, and fuel systems shall be filled before operating.

583-9.2.3 STEEL HULLS. In addition to the general items, the following shall be checked for on steel hulled boats:

- a. LCM's or other boats that are exposed to the weather when stored are to be protected from entrance of water, dirt, or contaminants into the interior spaces. Vents shall remain open for air circulation. Engine exhausts shall

S9086-TX-STM-010

be plugged with damage control type wood plugs. Engines shall be preserved as detailed in paragraph 583-9.2.2 through 583-9.21 or applicable MIP and MRCs.

- b. Drainage has been accomplished by trimming the boat, opening the existing drain plugs, or drilling drain holes.

CAUTION

Drain bilges under guidance of local regulations for HAZMAT. WARNING Vinyl paints are fire hazards until dry. c. Exterior and interior paint coats are maintained. Loose paint has been removed and rusty surfaces wire brushed or sanded. Apply one pretreatment coat of formula 117, DOD-P-15328 (NSN 8030-00-165-8577) followed by two coats of formula 120, MIL-P-15930 (NSN 8010-00-753-4714), vinyl zinc chromate primer.

583-9.2.4 PLASTIC HULLS. In addition to the general items, special care shall be taken to make certain that the weight of the boat rests upon the keel support, not the side bunks (chocks).

583-9.3 INVENTORY CONTROL POINT (ICP) RESPONSIBILITIES FOR STORAGE.

It is the responsibility of the Stock point to certify that turn-in and preservation procedures have been accomplished by the custodian activity. Once a boat has been accepted for turn-in, it is the responsibility of the stock point to accomplish the following storage requirements:

- a. Adequate shelter has been provided with sufficient side protection to prevent the access of rain or snow. There should be no leaks in the cover. Evidence of this is the absence of fresh water accumulation on the decks or in the bilges (CM's excepted).
- b. Boat is rigidly supported by keel blocking timbers (6-inch by 8-inch) placed beneath the keel at maximum intervals of 6-feet, or by a cradle designed for the boat.
- c. Side bunks (chocks) are used for preventing racking and not bearing weight as evidenced by absence of local hull deformation.
- d. Deformation of the hull by overhang at the stem and the transom ends is prevented by rigid supporting timbers and adequate padding to prevent damage to the plating or planking.
- e. Frost heaving or settling of the ground has not caused racking of the hull or deformation of the hull planking or plating at the side bunk (chocks).

583-9.4 DEPRESERVATION.

583-9.4.1 INVENTORY CONTROL POINT (ICP) POINT RESPONSIBILITIES FOR DE-PRESERVATION. Prior to releasing a boat to a receiving activity, the stock point is responsible for preparing the boat for issuable condition.

583-9.4.2 CUSTODIAN OR RECEIVING ACTIVITY RESPONSIBILITIES FOR DEPRESERVATION. Once released from the stock point, the receiving activity shall ensure all depreservation procedures have been accom-

plished and, in addition, ensure that receipt procedures and depreservation procedures have been accomplished as detailed in paragraphs 583-9.4 through 583-9.4.3.3 and the COTS manuals.

583-9.4.3 STARTING DIESEL ENGINES AFTER DEPRESERVATION.

CAUTION

Prior to commencing depreservation procedures, install the raw water pump impeller and tighten loose drive belts.

583-9.4.3.1 Lubrication System. Before operating an engine that has been out of service and treated with rust preventive compound, an external circulating pump shall be used to circulate lubricating oil through the engine at normal operating pressure. If equipped, the lubrication system external to the engine should be properly cleaned. The engine should be bypassed during this procedure to prevent excessive flushing and possible contamination of the engine bearings and lube oil passages with material dislodged during the cleaning procedure.

- a. **Checking Flow.** Jack or bar the engine over several revolutions during circulation of the lubricating oil. Inspection plates and covers should be removed and a visual check made to assure that the lubricating oil is reaching all points of the system; all main and connecting rod bearings, camshaft, blower bearings, rocker arms, and wrist pins. If it is found that lubrication is not reaching all points following this procedure, it will then be necessary to heat the lubricating oil being circulated to approximately 180°F and follow the same procedure. If, after this has been done, it is evident that stoppages exist in the lubrication system, it will be necessary to disassemble the engine and determine the cause of the trouble.
- b. **Prepare Engine for Starting.** When inspection shows that the lubrication system is functioning properly, the external pump can be secured, strainers cleaned, filter elements renewed, and the engine prepared for starting according to the engine technical manual. Prior to starting, ensure that all loosened drive belts are tightened, install raw water pump impeller with new gasket, remove blank plate from exhaust system and fill engine and marine gear lube oil systems to correct operating levels with lubricating oil.

583-9.4.3.2 Fuel System. The compound will be removed from the fuel system during the normal operation of the engine.

583-9.4.3.3 Cooling System. The following procedure should be followed in removing rust preventive compound from the cooling system:

NOTE

The following procedure shall not be used in systems containing aluminum.

CAUTION

Dispose of waste water under guidance of local regulations for HAZMAT.

S9086-TX-STM-010

NOTE

Run engine for 5 minutes during each flushing. The lubricating oil and water should be checked for contamination after a few hours of operation, then drained and replaced, if necessary.

1. Fill with fresh water and operate the engine for 5 minutes to ensure that no leaks are present in the cooling system.
2. Secure engine and drain water.
3. Fill the cooling system with a 2 percent sodium metasilicate (NSN 6810-00-664-7062), 0.1 percent detergent (NSN 7930-00-282-9699) solution in clean fresh water. This solution may be made up by adding a concentration of 16.7 pounds of sodium metasilicate and 0.83 pounds (approximately 0.5 pint) of detergent for each 100 gallons of solution required.
4. Start engine and operate for 2 hours, keeping solution temperature at 160°F.
5. Drain cleaning solution from cooling system.
6. Flush four times with fresh water to remove all traces of cleaning solution. Break several hose connections and examine waterside to ensure that it is clean.
7. If the engine is not clean, reassemble, refill with cleaning solution, and repeat cleaning and flushing operations.

SECTION 10 BARGES AND GIGS

583-10.1 CONVERSION OF STANDARD BOATS.

583-10.1.1 STANDARD ITEMS APPROVAL AND INSTALLATIONS. All conversions of Navy standard boats to barges and gigs shall be accomplished in a cost effective manner.

583-10.2 STANDARD ITEMS.

583-10.2.1 CONVERSION OF STANDARD BOATS TO BARGES AND GIGS. Barges and gigs, as outlined in paragraph 583-1.3.3, are authorized for installation of standard items listed in Table 583-10-1. Installation of these items shall be approved by type and fleet commanders for afloat commands and by the immediate senior in command for shore commands. In no instance shall installation of standard items and conversions be accomplished which will increase weight to exceed the hoisting weight shown on the boat's hoisting label plate or impair operational and performance characteristics or result in a decrease in safety. Installation of items on gigs beyond the standard items is not authorized.

583-10.2.2 STANDARD ITEMS APPROVAL AND FUNDING. Conversion of standard boats to barges and gigs, will be funded by Type or Fleet Commanders. Serviceable items or components not in conformance with Table 583-10-1, already installed in assigned boats, will be required to be removed when item is no longer serviceable. Buffed and polished CRES fittings, molding, and strips should be used wherever chrome-plated items are permitted, particularly if the item is commercially available at reasonable prices.

583-10.2.3 PAINTING OF BARGES AND GIGS. It is recommended that barges and gigs be painted in accordance with Table 583-10-2 using polyurethane or epoxy-type paint for decks, hull and boottop stripe, and anti-fouling bottom paint below the boottop stripe. It is also recommended that barges and gigs which are in continual use (not hoisted at frequent intervals) receive two coats of antifouling paint on the underwater body.

Table 583-10-1 Standard Items for Barges and Gigs

Standard Items	Barges	Gigs 1
Deck and engine cover caulked 2	Yes	No
Cabin trim		
If wood-varnish finish	Yes	Yes
If metal or plastic-white painted finish	Yes	Yes
Linoleum on flats or suitable indoor/ outdoor carpeting (fire retardant 3)	Yes	Cabin only
Seat cushions and curtains	Yes	Yes
Ladders, wood, varnish finish	Yes	Yes
Kickplates and treads, CRES, polished	Yes	Yes
Water closet	Yes	Yes
Galley	Yes	No
Swimmer's platform	Yes	No
Chrome plate 4		
Handrails	Yes	Yes

S9086-TX-STM-010

Table 583-10-1 Standard Items for Barges and Gigs - Continued

Standard Items	Barges	Gigs 1
Flagstaff, jackstaff, and mast	Yes	Yes
Sockets	Yes	Yes
Sockets	Yes	Yes
Bow lettering, nocks, arrowheads, and stars 5	Yes	Yes
Portable rings	Yes	Yes
Interior lighting fixtures	Yes	Yes
Fire extinguisher bracket	Yes	Yes
Chain plate	Yes	Yes
Taffrail and bow rail	Yes	Yes
Cleats	Yes	Yes
Beading and stem band 6	Yes	Yes
Horn, windshield fittings (less wipers)	Yes	Yes
Chocks	Yes	Yes
Towing post (if metal)	Yes	No
Engine control	Yes	Yes
Steering wheel (metal portions)	Yes	Yes
Searchlight	Yes	Yes
Deck vents and fuel covers	Yes	Yes
Chafing plate 7	Yes	Yes
Hatch moldings and fittings	Yes	Yes
Door and ladder fittings	Yes	Yes
Emergency tiller plate	Yes	Yes
Bell, bracket, and stand	Yes	No
Appropriate communications equipment 8	Yes	Yes

NOTES:

1. Boats converted and used as barges and gigs generally are standard U.S. Navy designs. Non-standard commercial boats may also be assigned for flag officer's use as barges. Those items which are welded or otherwise affixed to the hull in such a manner that excessive expenditures would be required for their removal and replacement shall not be chrome-plated.
2. Barges are authorized to have herringbone decks of unvarnished teak or herringbone decks consisting of varnished mahogany margins, king plank, and filler pieces with Alaska cedar or mahogany strakes. Caulked decks, if installed on standard craft being modified as gigs, shall not be removed.
3. Vinyl tile may be used in place of linoleum. Color is to be in harmony with cabin interior.
4. Where applicable, only the exposed portions of the items designated shall be chrome-plated. Stainless steel fittings shall not be chrome-plated as the purpose for the installation of these fittings is to avoid the cost of chrome-plating. Stainless steel fittings shall be polished.
5. Chrome-plated bow letters, nocks, and arrowheads may be installed on any boat used as a gig.
6. Polyurethane fenders are installed on new personnel boats and are selectively back fit by BOATALT on older boats. Maintainability is improved over the traditional white oak with stainless steel bar beading. The urethane fenders shall not be removed when a standard boat is issued as a barge or gig.
7. Chafing plate is non-standard equipment which should be installed on transom corner angles (badgers)
8. Equipment may be installed, permanent, or portable, to allow sufficient communications for command and safety purposes within the boat control station for the barge and gig operators.

Table 583-10-2 Recommended Colors for Barges and Gigs

Barges		Gigs	
Deck	White/Off White	Deck	Standard Navy Grey
Hull	Black	Hull	Standard Navy Grey
Boottop	3 White Stripe 1 Above Waterline	Bootstripe	3 Red Stripe 1 Above Waterline
Bottom	Medium Green or Tropical Green	Bottom	Black

SECTION 11

SPECIAL MISSION BOATS ANTI TERRORISM/FORCE PROTECTION AND SPECIAL MISSION BOATS AND CRAFT

583-11.1 GENERAL INFORMATION

The changing mission and mission environment that the U.S. Navy supports, require different types of boats and small craft. Since 2001 the Navy began procurement of Commercial-Off-The-Shelf (COTS) boats and craft that are used to support harbor patrol and security efforts, drug interdiction, search, air, and rescue (SAR), line handling duties, barrier tending, and escort duties.

583-11.2 FORCE PROTECTION/ANTI TERRORISM BOAT TYPES

583-11.2.1 HARBOR SECURITY (HS) AND PATROL BOATS (PB). Boats used to perform patrols, surveillance, and security related functions as required. Hull lengths and types will vary.

583-11.2.2 LINE HANDLING BOATS. This type of boat supports missions in harbors and ports as directed.

583-11.2.3 BARRIER BOATS (BB). Barrier boats are small tugs used to deploy and retrieve barriers in ports and harbors.

583-11.2.4 ESCORT BOATS Escort boats provide protection for ships and submarines entering and exiting ports and harbors.

583-11.3 FORCE PROTECTION/ANTI TERRORISM HULL CONSTRUCTION.

Boats and craft used as force protection or anti terrorism assets may be constructed from aluminum, fiber reinforced plastic (GRP), or steel.

583-11.3.1 COLLAR TYPES. Certain hulls may be fitted with an inflatable air chambered collar or a sheath that contains foam surrounding an air filled tube, or a foam filled collar mechanically attached to the hull at the sheer. Information specific to the tube fitted will be found in the boat information book (BIB).

583-11.4 ENGINES.

Individual boats will be fitted with inboard diesel engines or outboard gasoline engines. The type and size of engine depends on craft type and mission. a. Gasoline Outboard Engines: Two-or four-cycle-COTS engines. b. Inboard Diesel Engines: will be four-cycle COTS engines.

583-11.4.1 PROPULSION UNITS. Boats and craft must be fitted with a means of propulsion and maneuvering. Outdrives or water jets will be fitted on inboard engine configurations.

SECTION 12

LIFE RAFTS AND ABANDON SHIP BOAT

583-12.1 INTRODUCTION.

583-12.1.1 GENERAL. An inflatable life raft is one constructed of a coated fabric and inflated to its design shape by air or other gas. The raft is stowed aboard ship for use only as a life raft, when and as directed by the Commanding Officer.

583-12.1.2 TYPES OF INFLATABLE LIFE RAFTS. There are three basic Navy type inflatable life rafts for use throughout the fleet:

- a. MK6, 25-person, air inflated.
- b. MK7, 25-person, replaces the Mark (MK) 6.
- c. MK8, 50-person.

583-12.1.3 LIFE RAFT SPECIFICATIONS. The following military specifications and instructions apply for the construction of these rafts:

- a. MK6, MIL-L-24489 (inactive) which includes:
 1. Inflation Equipment, MIL-I-24490.
 2. Rigid container, MIL-C-24491.
 3. Inflation cylinder MIL-C-24604.
- b. Mark 7, Commercial Off The Shelf (COTS), U.S. Coast Guard approved with modifications provided in U.S. Navy container, Contract Number N00104-00-D-ZD00.
- c. Mark 8, COTS, U.S. Coast Guard approved with modifications provided in U.S. Navy designed container, Contract Number N00104-01-D-ZD07.

583-12.1.4 ABANDON SHIP BOAT. The ship shall designate one of its boats as the abandon ship boat for marshalling life rafts and recovering survivors during abandon ship situations. An abandon ship boat gear locker shall be installed near the boat. An abandon ship survival bag that contains the equipment shown in Table 583-12-1 and the following items:

- a. 4 boat oars (NSN 4220-00-268-9261)
- b. Twenty fathoms (120-feet) of 2-inch circumference nylon rope (NSN 4020-00-753-2887)
- c. Boat cover colored rescue orange with rigging for boats not having a fixed canopy.

The abandon ship survival bag and items a, b, and c shall be stowed in the abandon ship boat gear locker. The locker shall be similar to NAVSEA drawing number 53711-671-5107293 Survival Equipment Locker for

S9086-TX-STM-010

Abandon Ship Boat. The locker will have a label plate inscribed with "Abandon Ship Equipment - Load in boat upon hearing Abandon Ship Signal" attached to the locker.

Table 583-12-1 Abandon Ship Survival Bag Equipment¹

ITEM	QUANTITY	REMARKS	Ordering Information
Bag, Abandon Ship Survival	1	Kwik Tek Inc. Denver, Co	Dry Tek ASSB-1 (Blue)
Bailer, Plastic 2-Quart Capacity	1	Rubbermaid #2885 64-ozs	Commercial
Batteries, Alkaline "D" cell	4		6135-00-835-7210
Blanket, Casualty	4		7210-00-935-6666
Dimenhydrinate, 50 mg Tablets	100		6505-00-116-9660
First Aid Kit	1		6545-00-168-6893
Flashlight, Type II, Style A	1		6230-00-299-3035
Food Packet	10		8970-01-434-3192
Knife, Pocket	1		5110-00-162-2205
Mirror, Signaling Type II	1		6350-00-261-9772
Sea Marker, Fluorescent	1		6850-00-270-9986
Water Emergency Drinking	30	500-ml plastic bottle	8960-00-000-0170
Whistle, Signaling, Type II Plastic	1	Plastic, Type II	8464-00-254-8803

¹ The abandon ship survival bag equipment shall be inspected every 24-months in accordance with the appropriate MIP. The bag shall be sealed and stenciled with the ship hull number, date packed, and the name of the packing facility.

583-12.2 ALLOWANCES AND ISSUES.

583-12.2.1 CORRESPONDENCE. All correspondence related to inflatable rafts shall cite type (for example, MK7) and Mod number. Whenever the status of a life raft changes, the life raft database must be updated. This database can be queried via the Internet at www.boats.dt.navy.mil. Report all changes to Naval Surface Warfare Center, Detachment Norfolk, Carderock Division.

583-12.2.2 STANDARD SHIPBOARD ALLOWANCE. The allowance of inflatable life rafts for in-service ships is as follows:

- a. For ships with total accommodations greater than 295, life rafts shall be provided for 110 percent of accommodations, including surge or 110 percent of Manpower Authorization (MPA) whichever is greater. The number of rafts provided in excess of the number of rafts required to satisfy 100 percent of accommodations shall not exceed 12 25-person life rafts or six 50-person life rafts.
- b. For ships with total accommodations less than 295, life rafts shall be provided for 100 percent of accommodations, including surge, or 100 percent of MPA whichever is greater. The total number of life rafts shall be sufficient to retain life raft capacity for 100 percent of accommodations in the event that the largest cluster of life rafts is destroyed. A cluster is defined as life rafts being supported by a common structure. In calculating the number of life rafts required, any fractional value shall be increased to the next higher unit value.

583-12.2.3 CHANGES IN ALLOWANCE. Changes in allowance will be considered by Naval Sea Systems Command (NAVSEA) PEO Ships PMS 325 only upon presentation of information documenting a Chief of Naval Operations directed change to ship's mission, or an official revised Ship's Manning Document, OPNAV-INST 5320 (series) causing a change in the ship's accommodations.

583-12.2.4 HOW RAFTS ARE OBTAINED. MK 6 life rafts are being phased out of service as they reach 25-years of age. The transition from Mark 6 to Mark 7 life rafts will involve the inventory maintained by the life raft repair facilities. These life rafts shall be used to replace an inflatable life raft of ships allowance for reasons of loss, survey, or deferral for repair. To obtain, the new MK 7 or MK 8 life raft submit the requisition as required by current requisition procedures to the Navy Inventory Control Point (NAVICP), Mechanicsburg, PA. The following National Stock Numbers (NSN) apply:

- a. MK6, NSN 1940-01-015-7346 (only available through the life raft facility rotation pool).
- b. MK 7, NSN 4220-01-444-6260 (replaces the MK 6 life raft).
- c. MK 8, NSN 4220-01-475-3185 (50-person life raft).

583-12.3 REPORTS.

583-12.3.1 MAJOR REPAIR REPORTS. Major repair actions on life rafts shall be reported by certified repair facilities in accordance with NAVSEA S9008-AA-PRO-010 and forms listed therein. The repair shall be described briefly; it shall be identified and the date of release from shipboard and return to shipboard, shall be noted. The replacement raft number shall be provided if the raft is replaced. These completed forms shall be kept on file at the repair facilities for review by the NAVSEA certification team.

583-12.3.2 LIFE RAFT TURN-IN OR EXCHANGE. NAVICP Mechanicsburg does not maintain an inventory of life rafts. All life rafts shall be turned in at the nearest certified life raft repair facility for inclusion into the facility's pool for rotation.

583-12.3.3 RECEIPT OF NEW LIFE RAFT REPORT. Ships receiving new type life rafts will submit allowance Change Request/Report, NAVSUP Form 1220 to NAVSUP Form 1220 to NAVICP and NSWC Detachment Norfolk according to NAVSEAINST 4441.1.

583-12.4 DISPOSALS AND SURVEYS.

583-12.4.1 DISPOSAL OF LIFE RAFTS. An inflatable life raft shall not be disposed of or surveyed by ships' force except as noted in the following paragraph. Rafts that are determined to be unrepairable by designated repair and certification facilities shall be disposed of or surveyed in accordance with NAVSEA S9008-AA-PRO-010, Inspection, Test, and Repair Procedures for Life Raft Inflatable Mark 6, Mark 7, and Mark 8.

583-12.4.2 REPLACEMENT AT END OF 25-YEAR SERVICE LIFE. As part of pre-inspection and inflation testing, any life raft found to be 25-years or older prior to being repacked shall be considered unfit for further service and surveyed. Life rafts that become 25-years old after recertification may remain in service until they are again inducted at a repair facility under normal recertification requirements.

S9086-TX-STM-010

583-12.4.3 LOSS OF LIFE RAFT AT SEA. A raft lost at sea is considered surveyed.

583-12.4.4 CERTIFIED AND REPAIR FACILITIES DISPOSAL OF LIFE RAFTS. Disposals shall be made only by those designated repair and certification facilities listed in paragraph [583-12.11.1.1](#), in which case, all salvageable parts in good condition shall be removed and retained in local stock to be used again. The raft shall then be destroyed. The life raft database shall then be updated with an entry of the destruction.

583-12.4.5 LIFE RAFTS FROM SHIPS BEING DEACTIVATED. For ships being deactivated, refer to paragraph [583-12.3.2](#).

583-12.5 STOCK CLASSIFICATION, LEVELS, AND DISTRIBUTION.

583-12.5.1 CLASSIFICATION. Stock rafts are divided into categories listed in paragraphs [583-12.5.1.1](#) through [583-12.5.1.4](#).

583-12.5.1.1 Condition A. Any raft ready for issue from a certified repair facility.

583-12.5.1.2 Condition F. Any raft economically repairable but not issuable without repair.

583-12.5.1.3 Condition H. Any raft that is uneconomical to repair. Rafts in this category are considered unseviceable and shall be surveyed according to paragraph [583-12.4](#) when directed NAVSEA PMS 325.

583-12.5.1.4 Condition M. Any raft in process of repair, in transition from Condition F to Condition A. Stock rafts shall be placed in the foregoing categories only as a result of inspection by qualified personnel of designated repair and certified facilities. Refer to paragraph [583-12.11.1.1](#) for designated repair and certified facilities.

583-12.5.2 STOCK LEVELS. Based on demand, minimum stock levels of issuable rafts, by types, will be established at stocking activities.

583-12.5.3 DISTRIBUTION. Selection of rafts shall be on a first in and first out basis of Condition A rafts only, of the type and Mod to suit the individual ship requirements. Types and Mods shall be approved by NAVSEA PMS 325 if different from existing ship's rafts.

583-12.5.3.1 Repair Priority. Selection of rafts for repair to Condition A shall be from existing stocks of Condition F rafts determined to be most economical to repair, whenever possible.

583-12.5.3.2 Estimated Repair Costs. Estimated repair costs shall be reported on an approved NAVSEA Form and shall include (though separately identified from) costs to open and inspect.

583-12.6 IDENTIFICATION.

583-12.6.1 LIFE RAFT REGISTRY NUMBER. Each raft is assigned a registry number for purposes of identification. The number is molded into the raft's identification label attached to the hull tube on MK 6 life rafts or printed on a label glued to the floor on MK 7 and MK 8 life rafts.

583-12.7 CAPACITIES, WEIGHTS, AND DIMENSIONS.

583-12.7.1 LIFE RAFT CHARACTERISTICS. Normal operation of the life raft is accomplished by applying tension to the sea painter line that actuates the primary inflation cylinder. As inflation occurs, the brass securing bands on the container are broken as the life raft emerges. Should circumstances impede the normal inflation of the life raft, the life raft can sometimes still be deployed. Any cutting instrument, for example the scissors from the first aid kit of a deployed life raft, can be used to sever the brass securing bands of the containerized life raft. Remove the upper container half and locate the inflation cylinders. Under some circumstances the inflation cylinders can be actuated manually by extracting the inflation cable. Table 583-12-2 lists characteristics for inflatable life rafts.

Table 583-12-2 Characteristics for Inflatable Life Rafts

RAFT TYPE	CAPACITY	WEIGHT (LBS)	DIMENSION INFLATED L W H	DIMENSION CONTAINER H WL
Mark 6	25-Person	500	17' -10" 8' -10"	27" x 56"
Mark 7	25-person	295	13' 5 3/4" 13' 5 3/4 " 6' 2 3/4"	27" x 56"
Mark 8	50-person	585	21' 7 3/4 " x 17' 3 3/4 " 8" 6 3/8"	35" x 65"

583-12.7.2 CONTAINER DESIGN. The container design is detailed on NAVSEA drawing number 803-4382176 for the Mark 6, manufacturers drawing number RFD-D-45132 for the Mark 7, and NAVSEA drawing number 583-5106577 for the Mark 8. The containers are capable of withstanding a free fall drop of 23 meters (65 feet) from stowage into the water.

583-12.8 EQUIPMENT AND REPAIR PARTS.

583-12.8.1 SURVIVAL GEAR AND REPAIR PARTS FOR MK 6, MK 7, AND MK 8 LIFE RAFTS. With the installation of encapsulated life rafts, the survival gear and repair parts become raft allowance (stowed within the fiberglass container, inaccessible to the ship's crew until deployed).

583-12.8.2 LIST OF SURVIVAL GEAR FOR EACH TYPE LIFE RAFT. Table 583-12-3 lists the survival gear provided for each type of raft.

Table 583-12-3 Table 583-12-3. Survival Gear

ITEM	DESCRIPTION	SPECIFICATION	NSN	QUA (MA)
1	Food Packet (Individual Ration) or Food Packet, Survival Abandon Ship	MIL-F-16895CID (A-A-20247	8970-00-299-1395- 01-434-3192	12

S9086-TX-STM-010

Table 583-12-3 Table 583-12-3. Survival Gear - Continued

ITEM	DESCRIPTION	SPECIFICATION	NSN	QUA (MA)
2	Water, Plastic Container (500ml)		8960-00-000-0170	2
3	Manual Reverse Osmosis Desalinator (MROD)		4610-00-372-0592	
4	Storage Bag, Drinking Water, Size A	MIL-B-8571	8465-00-485-3034	
5	Flashlight (2 Cell) Type II Style I, or Type III Style I	MIL-F-3747	6230-00-269-30346230-00-299-3035	
6	Battery, Dry, Flashlight Alkaline D	W-B-101	6135-00-835-7210	
7	Sea Marker, Fluorescent	MIL-S-17980	6850-00-270-9986	
8	Mirror, Signaling, Type II	MIL-M-18371	6350-00-261-9772	
9	Sponge, Cellulose Type II Size 3, Porosity A	L-S-626	7920-00-240-2559	
10	Knife, General Purpose, Pocket	MIL-K-818	5110-00-162-2205	
11	Whistle, Signaling, Plastic, Type II	MIL-W-1053	8465-00-254-8803	
12	Motion Sickness Tablets Dimenhydrate, 50mg		6506-00-116-9660	3
13	Bailer, Plastic, 2 Qt. Capacity	Commercial		
14	Kit, First Aid		6545-00-168-6893	
15	Kit, Abandon Ship Signal		1370-01-366-0344	
16	Kit, Fishing Survival	MIL-F-6218	4220-00-125-8751	
17	Flashlight Bulb (PR6)		6240-00-155-8675	
18	Blanket, Combat Casualty (84 x55)	Commercial		
19	Hand Pump, Air with Hose and Adapter	MIL-P-12647	4320-00-299-2229	
20	Sealing Clamp, 3 inch	MIL-R-52255	5340-00-720-8864	
21	Sealing Clamp, 5 inch	MIL-R-52255	5340-00-720-8863	
22	Sealing Clamp, 7 1/2 inch	MIL-R-52255	5340-00-720-8858	
23	Container, equipment	Dwg. 805-4382177	4220-00-138-7118	
24	Oars	MS26529-2	2040-00-268-9261	
25	Sea Anchor with Line Type 2Size 1	MIL-A-3339	2040-00-368-2880	
26	Rescue Line		4220-01-006-6103	

583-12.9 STOWAGE AND HANDLING.

583-12.9.1 STOWAGE. Inflatable life raft stowages should be located to permit ready manual overboard launching into the water without hitting obstructions; to be clear of overhead obstructions; to avoid adverse effects of gun, missile and jet blasts and heavy seas; and to interfere as little as possible with normal shipboard activity. They shall be located, longitudinally, where they will provide the maximum practical distribution of life-saving facilities. The preferred orientation of the life raft in the stowage is with the seam of the upper and lower halves of the container positioned approximately parallel to the baseline of the ship and the sea painter line exiting the life raft container facing the aft end of the ship. Furthermore, all caution labels shall be plainly visible. They shall be provided and stowed in accordance with appropriate NAVSEA standard drawings.

583-12.9.1.1 Hydrostatic Release. Equipment for securing the rafts in their stowages shall include a hydrostatic release device. This device may be a can-type hydrostatic release device,, NAVSEA DWG 803-5959322 or a diaphragm-type hydrostatic release, MIL-R-15041 with spring tensioner that permits automatic and manual release. Neither item is currently manufactured or in stock. When hydrostatic release devices require replacement, a commercial design, Thanner model DK84.1M, NSN 1H-4220-01493-9233 shall be used. The can-type and the diaphragm-type hydrostatic release devices permit release of the life raft from stowage at approximately 10-40 feet in event of the ship sinking. The Thanner DK84.1M hydrostatic release device will release the raft from stowage at a seawater depth of approximately 5-15 feet.

583-12.9.1.2 Sea Painter. The life raft sea painter shall be attached directly to the ship structure adjacent to the stowage location.

583-12.9.2 HANDLING. Care should be taken in handling inflatable life rafts during shipping in and out of stowage, inspection, and transportation to and from repair facilities. To minimize damage to the life raft during transportation each life raft should be banded to a wooden pallet. The life raft should be lifted and carried using the molded handholds in the fiberglass container or an approved NAVSEA lifting sling as shown on Norfolk Naval Shipyard drawing 4712507 for the Mark 6 life raft. Care shall be exercised to ensure that the sealing bands are not inadvertently cut or damaged.

583-12.9.2.1 Covered Storage. Storage areas for life rafts shall be dry and free from effects of weather and from heat concentrations such as steam pipes. Warehouses or other covered storage spaces shall be utilized wherever possible.

583-12.10 INSPECTION

583-12.10.1 TYPES OF PERIODIC MAINTENANCE. Inspections shall be made at the following levels of responsibility to ensure that rafts, stowages, handling equipment, survival gear, and rations are satisfactory for emergency use:

- a. Organizational level (shipboard) includes inspection of the container, raft stowage, and handling equipment in accordance with the maintenance index page (MIP) and applicable maintenance requirement cards (MRCs).
- b. Depot level (repair facility) will open and inspect the raft and the container contents replacing outdated survival gear and rations. Perform minor and major repair, tests, and repacking.

S9086-TX-STM-010

583-12.10.2 STOWAGE SECURING HARNESS. The stowage securing harness shall be inspected to ensure proper tension and that

- a. Stowages with the can-type hydrostatic or the diaphragm type hydrostatic release without the spring tensioner shall be torqued 8 to 10 pounds foot.
- b. Harnesses used on stowages with the diaphragm type hydrostatic release shall be tightened until the life raft is securely seated in its cradle but so as not to damage the life raft container.

583-12.10.2.1 Hydrostatic Release. The hydrostatic release assembly shall be visually checked. Correct tightness of the securing harness (refer to paragraph [583-12.10.2](#)) shall be ensured. The release assembly shall not be painted. In event the release assembly is painted, it shall be removed and replaced. Removed release assemblies shall be turned in to a repair facility for refurbishing and testing.

583-12.10.2.1.1 Hydrostatic Release Installation. The can-type hydrostatic release device shall be installed with the end bracket having the hairpin connected to the retaining harness and the open end of the can shield facing the aft-end of the ship. The hairpin shall be installed in a direction to facilitate removal. The diaphragm-type hydrostatic release device shall be installed with the smaller end bracket connected to the retaining harness. The pushbutton shall face away from traffic to prevent inadvertent release. Since the Thanner DK84.1M device has a safety pin to prevent inadvertent release, the pushbutton of that device should face toward traffic for easy release when required.

583-12.10.2.1.2 Securing Sea Painter. The sea painter line from the container shall be checked to ensure that it is securely tied directly to the ship's structure, and accessible to the person launching the raft. The end of the sea painter is dyed red to provide a visual indicator that the length has not been altered. If the red end of the sea painter is not visible, a certified life raft repair facility shall be contacted and repairs made.

583-12.10.2.1.3 Inspect The Stowage Location. The rigid container and stowage interface shall be visually inspected to ensure that the stowed raft is sitting snug in the cradle and not subject to shifting.

583-12.10.2.1.4 Inspection and Test. With the periodicity stated in the appropriate maintenance index page (MIP), the rafts shall be turned in to a certified repair facility for inspection and testing. The maintenance periodicity of 48-months has been extended to 60-months for life rafts certified on or after 1 Jan 2004. All other life rafts have a maintenance periodicity of 48-months as explained by the appropriate MIP. The current maintenance periodicity of 48-months is being extended to 60-months, however this is only applicable to life rafts that have been certified for the 60-month periodicity as explained by the appropriate MIP.

583-12.10.3 DEPOT LEVEL. Inspection, major, or minor repair of the various rafts (paragraph [583-12.10.1](#)) shall be accomplished by an approved certified repair facility (paragraph [583-12.11.1.1](#).)

1. Conduct all applicable tests and inspections on raft, equipment, and systems listed in the appropriate technical manuals.
2. Make any major and minor repairs as necessary.

583-12-8

583-12.11 SERVICING AND MAINTENANCE.

583-12.11.1 **SERVICING.** A facility that will provide service to life rafts is any NAVSEA approved activity designated to accomplish minor and major repairs, inspection, maintenance, and survey of inflatable rafts. These facilities are annually certified by a NAVSEA certification team. The following designated activities are presently certified repair facilities:

- a. Norfolk Naval Shipyard
- b. SRF Yokosuka, Japan
- c. SIMA, Mayport, FL
- d. SIMA, San Diego, CA
- e. RFD-Beaufort, Inc., Sharon Center, Ohio, Original equipment manufacturer (OEM) for the Mark 7 and Mark 8 life raft.

583-12.11.1.1 **Repair** A repair is the correction of a problem which, when completed, will restore a raft to a reliable condition.

583-12.11.1.2 **Maintenance.** Life rafts that require repair or recertification shall only be accomplished by an activity designated in paragraph [583-12.11.1](#) and in accordance with S9008-AA-PRO-010 and the various appropriate maintenance bulletins issued by NAVSEA.

583-12.12 RAFT CERTIFICATION AND EXCHANGE.

583-12.12.1 **INSPECTION, CERTIFICATION AND EXCHANGE.** Upon receipt of ships' inflatable life rafts for inspection and recertification or repair the depot level activities shall accomplish inspections, tests, and repairs as cited in paragraphs of this section.

583-12.12.2 **TEST OF THE HYDROSTATIC RELEASE.** During each ships regular overhaul the diaphragm hydrostatic release will be the only type tested. The test shall consist of a load test equal to the capacity of the device, 800 pounds or 2500 pounds shall be applied by means of actual weights or applied tension. The device shall then be submerged in water or subjected to an equivalent air pressure in a chamber. The device shall automatically release at a depth of 25-feet (plus or minus 15-feet) or at the equivalent pressure. The U.S. Coast Guard approved Thanner DK84.1M device will automatically release at a depth of 5 to 15 feet of water or at an equivalent pressure. **WARNING** The can-type hydrostatic release device shall not be tested as noted above. The can-type hydrostatic device is a non-testing device and will self-destroy if pressure tested.

583-12.12.2.1 **Can-Type Hydrostatic Release.** The can-type hydrostatic release device shall be inspected by dimensional checks. Measure the overall dimension of the can at two places approximately 90 degrees apart along the longitudinal axis of the can. **CAUTION** Use micrometer dial indicating calipers, or other appropriate machinists' methods. Using rulers, yardsticks, or tape measures do not have the required accuracy and are not appropriate.

S9086-TX-STM-010

NOTE

The end cap of the can protrudes slightly beyond the open end of the shield.
Ensure that the overall can length is measured and not the stainless steel shield.

583-12.12.2.2 Can Measurement. If the can measures less than 4.16 inches from end-to-end, it is outside acceptable limits and should not be used. Cans measuring 4.16 inches or greater are acceptable. Locally dispose of any device that is dimensionally unsuitable.

APPENDIX A**TECHNICAL MANUAL DEFICIENCY/EVALUATION REPORT(TMDER)****NOTE**

Ships, training activities, supply points, depots, Naval Shipyards, and Supervisors of Shipbuilding are requested to arrange for the maximum practical use and evaluation of NAVSEA technical manuals. All errors, omissions, discrepancies, and suggestions for improvement to NAVSEA technical manuals shall be reported to the Commander, NAVSURFWARCENDIV, 4363 Missile Way, Port Hueneme, CA 93043-4307 in NAVSEA/SPAWAR Technical Manual Deficiency/Evaluation Report (TMDER), NAVSEA Form 4160/1. To facilitate such reporting, print, complete, and mail NAVSEA Form 4160/1 below or submit TMDERS at web site <http://nsdsa.phdnswc.navy.mil/tmder/tmder.htm>. All feedback comments shall be thoroughly investigated and originators will be advised of action resulting therefrom.

TMDER / MAILER

