

INCH-POUND

MS8009C
w/AMENDMENT 1
09 September 2005
SUPERSEDING
MS8009C
24 September 2003

DETAIL SPECIFICATION SHEET

HOSE ASSEMBLY, POLYTETRAFLUOROETHYLENE, PERMANENTLY ATTACHED
FITTINGS, HIGH TEMPERATURE, MEDIUM PRESSURE, FLANGE-TO-FLANGE

This specification is approved for use by all
Departments and Agencies of the Department of Defense.

The requirements for acquiring the product described herein shall consist of this specification sheet and MIL-DTL-25579.

Hose assembly dimensions for style A: See table I.

TABLE I. Hose assembly dimensions for style A. ^{1/}

Fitting ends		Hose size	Dimensions ^{2/}		
1	2		C (max)	M (max)	P (max)
Straight	Straight	8	0.880	1.560	0.875
		10	0.967	1.570	1.000
		12	1.122	1.640	1.250
		16Z	1.480	1.750	1.500
		20Z	1.750	1.990	1.844
		24Z	2.150	2.260	2.125

^{1/} Style A uses class 1 fittings which are made from corrosion resistant steel (CRES).

^{2/} Dimensions are shown on figure 1.

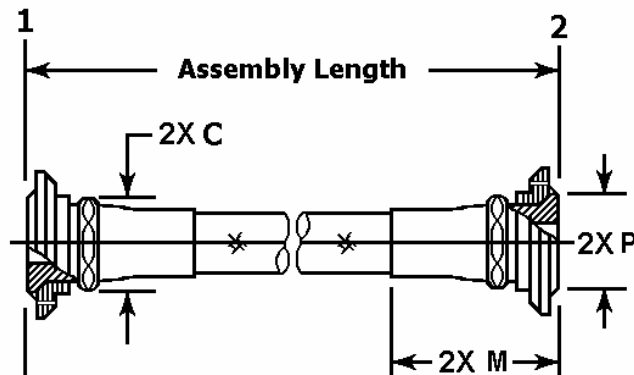

FIGURE 1. Style A hose assembly.

MS8009C
w/AMENDMENT 1

Hose assembly dimensions for style B: See table II.

TABLE II. Hose assembly dimensions for style B. 1/

Fitting ends		Hose size	Dimensions <u>2/</u>						
1	2		C (max)	D (max)	M (max)	N (max)	P (max)	R (min)	R (max)
Straight	45°	8	0.880	1.722	1.560	0.606	0.875	0.303	0.428
		10	0.967	2.037	1.570	0.658	1.000	0.340	0.465
		12	1.122	2.368	1.640	0.789	1.250	0.433	0.558
		16Z	1.480	2.583	1.750	0.929	1.500	0.470	0.657
		20Z	1.750	2.946	1.990	1.020	1.844	0.534	0.721
		24Z	2.150	3.210	2.260	1.186	2.125	0.589	0.839

1/ Style B uses class 1 fittings which are made from CRES.

2/ Dimensions are shown on figure 2.

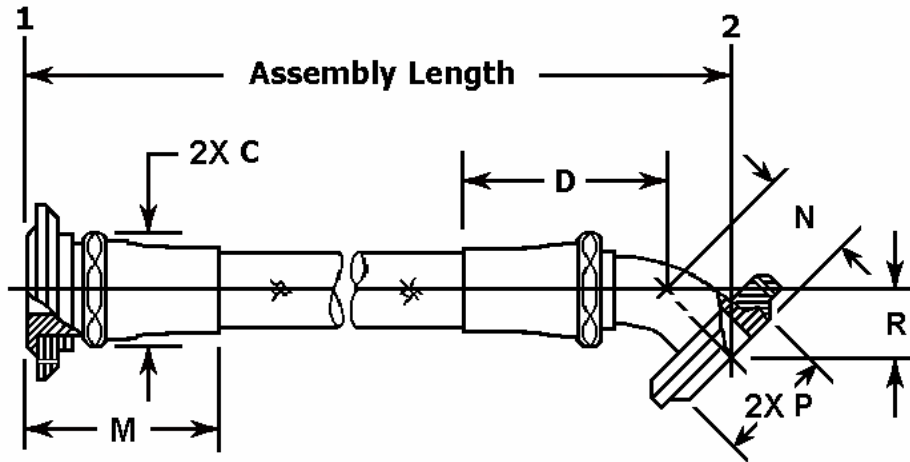

FIGURE 2. Style B hose assembly.

Hose assembly dimensions for style C: See table III.

TABLE III. Hose assembly dimensions for style C. 1/

Fitting ends		Hose size	Dimensions <u>2/</u>						
1	2		C (max)	M (max)	P (max)	S (max)	T (max)	U (min)	U (max)
Straight	90°	8	0.880	1.560	0.875	2.320	1.422	0.857	0.982
		10	0.967	1.570	1.000	2.875	1.499	0.861	1.015
		12	1.122	1.640	1.250	3.606	1.807	1.032	1.246
		16Z	1.480	1.750	1.500	3.981	2.174	1.156	1.434
		20Z	1.750	1.990	1.844	4.435	2.590	1.344	1.715
		24Z	2.150	2.260	2.125	5.075	3.103	1.516	2.028

1/ Style C uses class 1 fittings which are made from CRES.

2/ Dimensions are shown on figure 3.

MS8009C
w/AMENDMENT 1

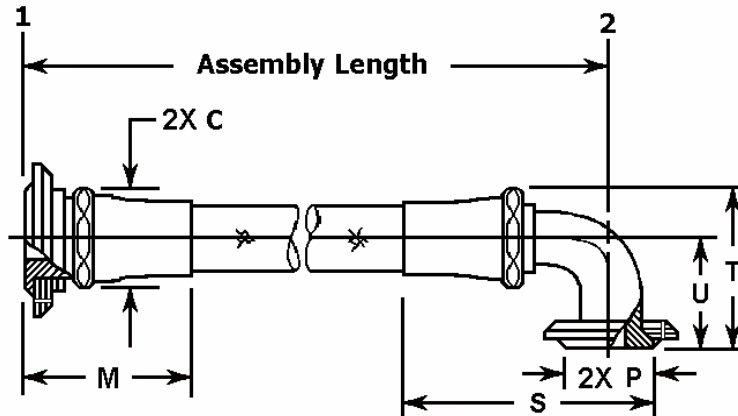

FIGURE 3. Style C hose assembly.

Hose assembly dimensions for style D: See table IV.

TABLE IV. Hose assembly dimensions for style D. 1/

Fitting ends		Hose size	Dimensions 2/					
1	2		C (max)	D (max)	N (max)	P (max)	R (min)	R (max)
45°	45°	8	0.880	1.722	0.606	0.875	0.303	0.428
		10	0.967	2.037	0.658	1.000	0.340	0.465
		12	1.122	2.368	0.789	1.250	0.433	0.558
		16Z	1.480	2.583	0.929	1.500	0.470	0.657
		20Z	1.750	2.946	1.020	1.844	0.534	0.721
		24Z	2.150	3.210	1.186	2.125	0.589	0.839

1/ Style D uses class 1 fittings which are made from CRES.

2/ Dimensions are shown on figure 4.

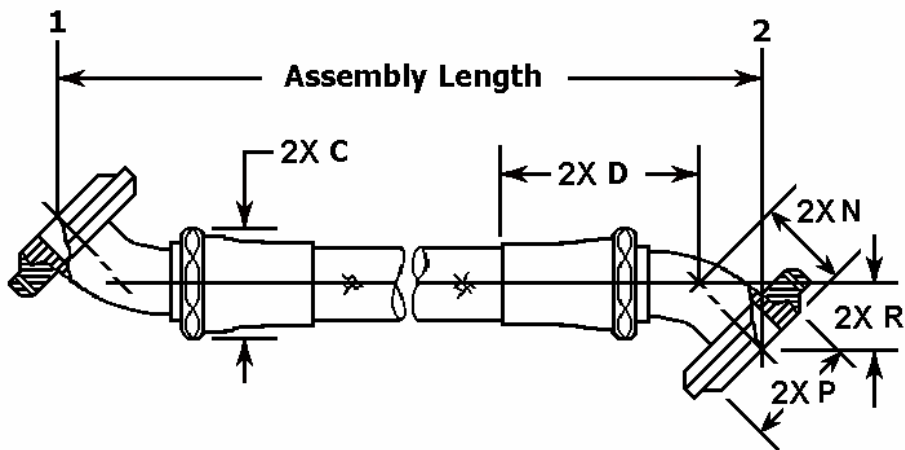

FIGURE 4. Style D hose assembly.

MS8009C
w/AMENDMENT 1

Hose assembly dimensions for style E: See table V.

TABLE V. Hose assembly dimensions for style E. 1/

Fitting ends		Hose size	Dimensions 2/									
			C (max)	D (max)	N (max)	P (max)	R (min)	R (max)	S (max)	T (max)	U (min)	U (max)
1	2											
45°	90°	8	0.880	1.722	0.606	0.875	0.303	0.428	2.320	1.422	0.857	0.982
		10	0.967	2.037	0.658	1.000	0.340	0.465	2.875	1.499	0.861	1.015
		12	1.122	2.368	0.789	1.250	0.433	0.558	3.606	1.807	1.032	1.246
		16Z	1.480	2.583	0.929	1.500	0.470	0.657	3.981	2.174	1.156	1.434
		20Z	1.750	2.946	1.020	1.844	0.534	0.721	4.435	2.590	1.344	1.715
		24Z	2.150	3.210	1.186	2.125	0.589	0.839	5.075	3.103	1.516	2.028

1/ Style E uses class 1 fittings which are made from CRES.

2/ Dimensions are shown on figure 5.

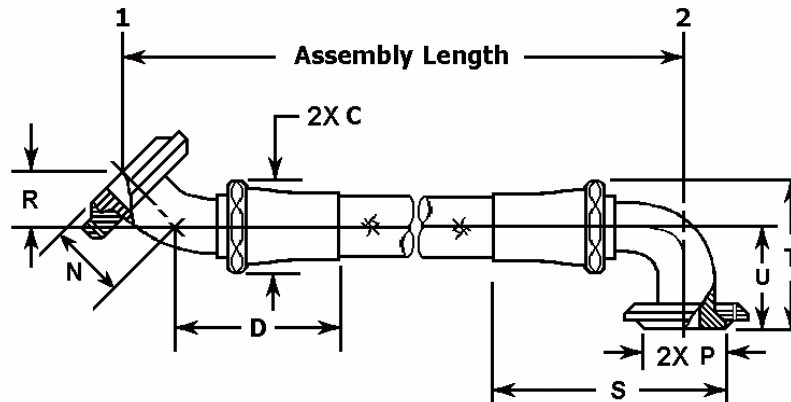

FIGURE 5. Style E hose assembly.

Hose assembly dimensions for style F: See table VI.

TABLE VI. Hose assembly dimensions for style F. 1/

Fitting ends		Hose size	Dimensions 2/					
			C (max)	P (max)	S (max)	T (max)	U (min)	U (max)
1	2							
90°	90°	8	0.880	0.875	2.320	1.422	0.857	0.982
		10	0.967	1.000	2.875	1.499	0.861	1.015
		12	1.122	1.250	3.606	1.807	1.032	1.246
		16Z	1.480	1.500	3.981	2.174	1.156	1.434
		20Z	1.750	1.844	4.435	2.590	1.344	1.715
		24Z	2.150	2.125	5.075	3.103	1.516	2.028

1/ Style F uses class 1 fittings which are made from CRES.

2/ Dimensions are shown on figure 6.

MS8009C
w/AMENDMENT 1

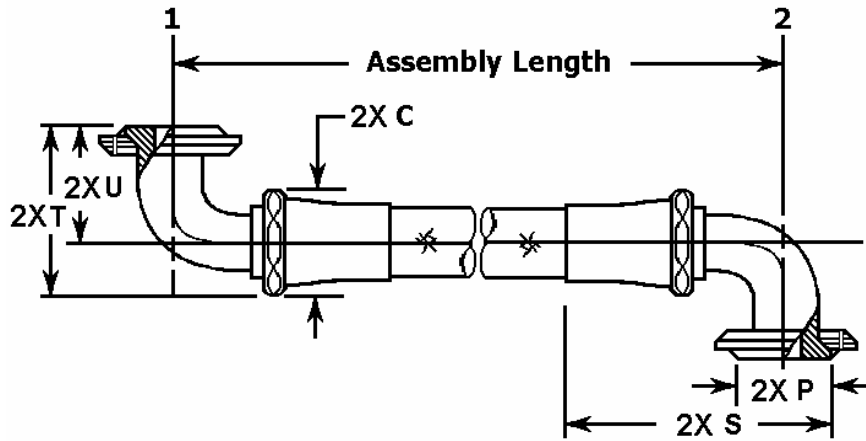

FIGURE 6. Style F hose assembly.

Hose assembly dimensions for style G: See table VII.

TABLE VII. Hose assembly dimensions for style G. 1/

Fitting ends		Hose size	Dimensions <u>2/</u>		
1	2		C (max)	M (max)	P (max)
Straight	Straight	8	0.880	1.560	0.875
		10	0.967	1.570	1.000
		12	1.122	1.640	1.250
		16Z	1.480	1.750	1.500
		20Z	1.750	1.990	1.844
		24Z	2.150	2.260	2.125

1/ Style G uses class 2 fittings which are made from a combination of aluminum and CRES.

2/ Dimensions are shown on figure 7.

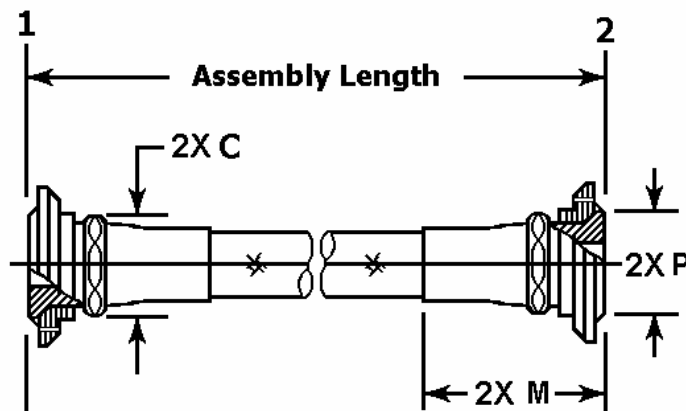

FIGURE 7. Style G hose assembly.

MS8009C
w/AMENDMENT 1

Hose assembly dimensions for style H: See table VIII.

TABLE VIII. Hose assembly dimensions for style H. 1/

Fitting ends		Hose size	Dimensions 2/						
1	2		C (max)	D (max)	M (max)	N (max)	P (max)	R (min)	R (max)
Straight	45°	8	0.880	1.722	1.560	0.606	0.875	0.303	0.428
		10	0.967	2.037	1.570	0.658	1.000	0.340	0.465
		12	1.122	2.368	1.640	0.789	1.250	0.433	0.558
		16Z	1.480	2.583	1.750	0.929	1.500	0.470	0.657
		20Z	1.750	2.946	1.990	1.020	1.844	0.534	0.721
		24Z	2.150	3.210	2.260	1.186	2.125	0.589	0.839

1/ Style H uses class 2 fittings which are made from a combination of aluminum and CRES.

2/ Dimensions are shown on figure 8.

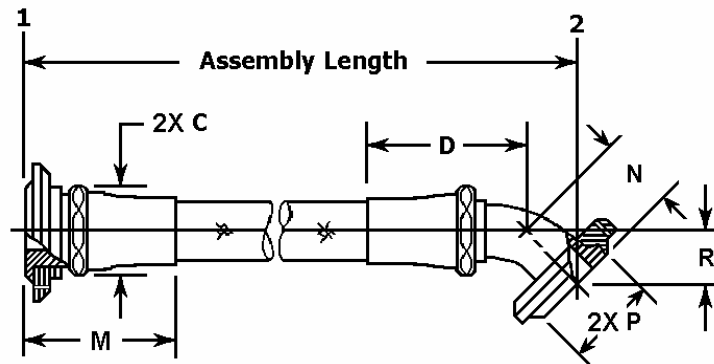

FIGURE 8. Style H hose assembly.

Hose assembly dimensions for style J: See table IX.

TABLE IX. Hose assembly dimensions for style J. 1/

Fitting ends		Hose size	Dimensions 2/						
1	2		C (max)	M (max)	P (max)	S (max)	T (max)	U (min)	U (max)
Straight	90°	8	0.880	1.560	0.875	2.320	1.422	0.857	0.982
		10	0.967	1.570	1.000	2.875	1.499	0.861	1.015
		12	1.122	1.640	1.250	3.606	1.807	1.032	1.246
		16Z	1.480	1.750	1.500	3.981	2.174	1.156	1.434
		20Z	1.750	1.990	1.844	4.435	2.590	1.344	1.715
		24Z	2.150	2.260	2.125	5.075	3.103	1.516	2.028

1/ Style J uses class 2 fittings which are made from a combination of aluminum and CRES.

2/ Dimensions are shown on figure 9.

MS8009C
w/AMENDMENT 1

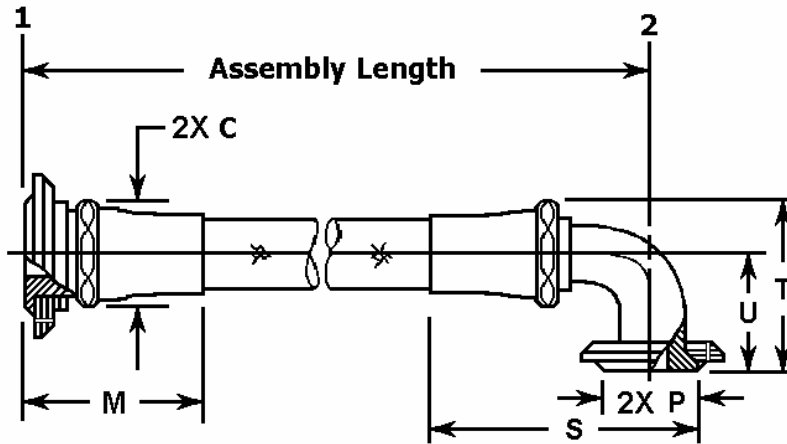

FIGURE 9. Style J hose assembly.

Hose assembly dimensions for style K: See table X.

TABLE X. Hose assembly dimensions for style K. 1/

Fitting ends		Hose size	Dimensions 2/					
1	2		C (max)	D (max)	N (max)	P (max)	R (min)	R (max)
45°	45°	8	0.880	1.722	0.606	0.875	0.303	0.428
		10	0.967	2.037	0.658	1.000	0.340	0.465
		12	1.122	2.368	0.789	1.250	0.433	0.558
		16Z	1.480	2.583	0.929	1.500	0.470	0.657
		20Z	1.750	2.946	1.020	1.844	0.534	0.721
		24Z	2.150	3.210	1.186	2.125	0.589	0.839

1/ Style K uses class 2 fittings which are made from a combination of aluminum and CRES.

2/ Dimensions are shown on figure 10.

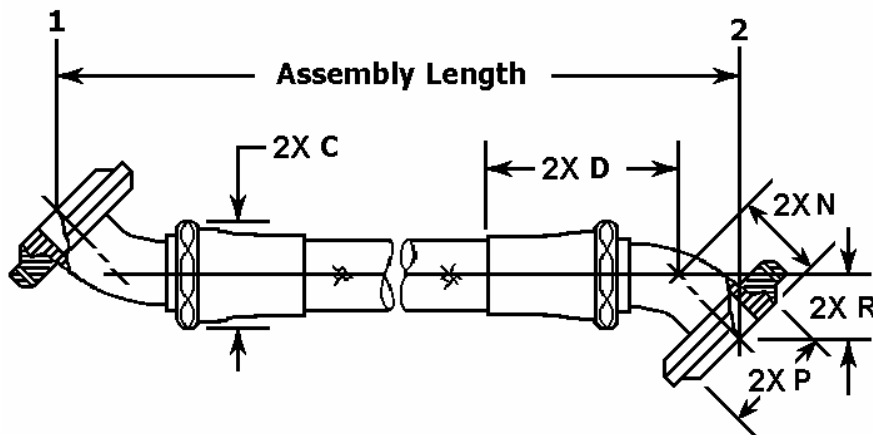

FIGURE 10. Style K hose assembly.

MS8009C
w/AMENDMENT 1

Hose assembly dimensions for style M: See table XI.

TABLE XI. Hose assembly dimensions for style M. 1/

Fitting ends		Hose size	Dimensions 2/									
			C (max)	D (max)	N (max)	P (max)	R (min)	R (max)	S (max)	T (max)	U (min)	U (max)
1	2											
45°	90°	8	0.880	1.722	0.606	0.875	0.303	0.428	2.320	1.422	0.857	0.982
		10	0.967	2.037	0.658	1.000	0.340	0.465	2.875	1.499	0.861	1.015
		12	1.122	2.368	0.789	1.250	0.433	0.558	3.606	1.807	1.032	1.246
		16Z	1.480	2.583	0.929	1.500	0.470	0.657	3.981	2.174	1.156	1.434
		20Z	1.750	2.946	1.020	1.844	0.534	0.721	4.435	2.590	1.344	1.715
		24Z	2.150	3.210	1.186	2.125	0.589	0.839	5.075	3.103	1.516	2.028

1/ Style M uses class 2 fittings which are made from a combination of aluminum and CRES.

2/ Dimensions are shown on figure 11.

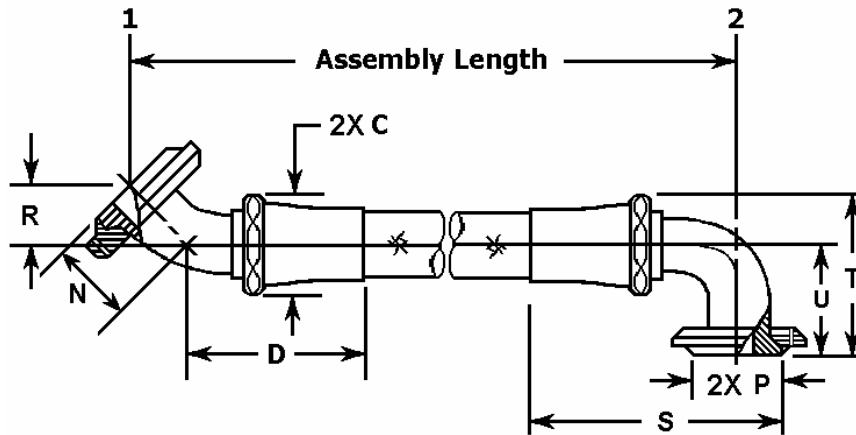

FIGURE 11. Style M hose assembly.

Hose assembly dimensions for style N: See table XII.

TABLE XII. Hose assembly dimensions for style N. 1/

Fitting ends		Hose size	Dimensions 2/					
			C (max)	P (max)	S (max)	T (max)	U (min)	U (max)
1	2							
90°	90°	8	0.880	0.875	2.320	1.422	0.857	0.982
		10	0.967	1.000	2.875	1.499	0.861	1.015
		12	1.122	1.250	3.606	1.807	1.032	1.246
		16Z	1.480	1.500	3.981	2.174	1.156	1.434
		20Z	1.750	1.844	4.435	2.590	1.344	1.715
		24Z	2.150	2.125	5.075	3.103	1.516	2.028

1/ Style N uses class 2 fittings which are made from a combination of aluminum and CRES.

2/ Dimensions are shown on figure 12.

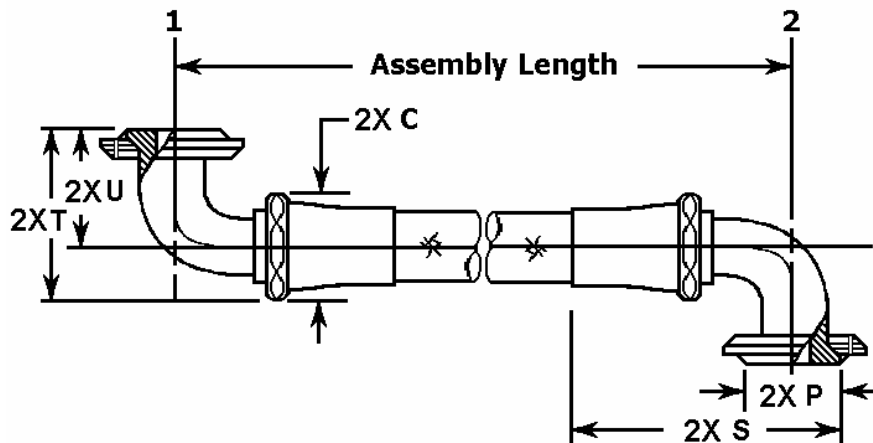
MS8009C
w/AMENDMENT 1FIGURE 12. Style N hose assembly.

Protective sleeve code: See table XIII.

TABLE XIII. Protective sleeve code.

Code	Type
A	SAE AS1072 sleeve, fire protection, silicone covered, temperature ranging from -65°F to 450°F and intermittently to 500°F, secured with CRES bands as required. ^{1/}
B	SAE AS1073 - code B sleeve, abrasion protection, heat shrinkable, black polyolefin, temperature ranging from -65°F to 250°F.
C	SAE AS1291 - code A sleeve, chafe guard, extruded seamless white PTFE, temperature ranging from -65°F to 450°F, secured with CRES bands as required.
D	SAE AS1291 - code C sleeve, chafe guard, extruded seamless transparent FEP, temperature ranging from -65°F to 350°F, secured with CRES bands as required.
E	SAE AS1298 sleeve, heavy wall chafe guard, extruded seamless black PTFE, temperature ranging from -65°F to 450°F, secured with CRES bands as required.
L	Lock-wire hole
F	Code A + L
G	Code B + L
H	Code C + L
J	Code D + L
K	Code E + L

^{1/} To prevent wicking of fluids, the cut ends of the fire protective sleeve (code A) shall be coated with Room Temperature Vulcanized (RTV) silicone rubber prior to installation. After installation, cracks and voids in the fire protective sleeve shall be coated with RTV rubber to prevent exposure of fiberglass.

MS8009C
w/AMENDMENT 1

Hose assembly size code: See table XIV.

TABLE XIV. Hose assembly size code.

Size	Reference tube OD	Size code
8	0.500	H
10	0.625	J
12	0.750	K
16Z	1.000	M
20Z	1.250	N
24Z	1.500	P

REQUIREMENTS

Dimensions: Unless otherwise specified, all dimensions are in inches. Dimensions “N (max)” and “T (max)” are installation dimensions and not design dimensions.

Fittings: The swivel flange shall conform to MS20756. The nut threads shall be in accordance with SAE AS8879.

Assembly classification: Class 1 and class 2 hose assemblies, as specified in MIL-DTL-25579, have been incorporated into the Part or Identifying Number (PIN) as a part of styles.

Angular alignment: Hose assemblies with elbow fittings on each end shall have the angular orientation between the elbows measured counter-clockwise from the centerline of the nearest fitting, positioned at six-o'clock, to the centerline of the other fitting (see figure 13). When applicable, the angular alignment shall be expressed in three digits and specified in the PIN.

Protective sleeve: If required, the hose assembly shall include a protective sleeve (see table XIII) and its code shall be included in the PIN. Fire protective sleeve shall be subjected to testing in accordance with MIL-DTL-25579.

Assembly length: Hose assembly shall be furnished in lengths as specified in the contract or purchase order (see MIL-DTL-25579); however, tolerances on the length of each hose assembly shall be as follows:

- a. $\pm 1/8$ inch for lengths under 18 inches.
- b. $\pm 1/4$ inch for lengths from 18 inches to 36 inches.
- c. $\pm 1/2$ inch for lengths from 36 inches to 50 inches.
- d. $\pm 1\%$ for lengths over 50 inches.

MS8009C
w/AMENDMENT 1

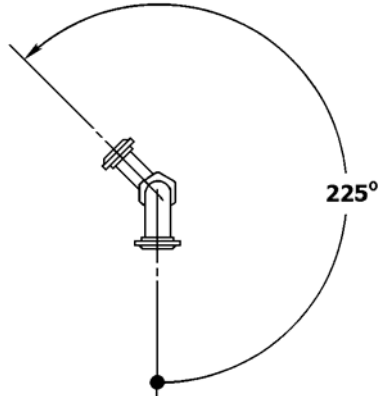

NOTE: Angular alignment shall be measured in degrees with a tolerance of $\pm 2^\circ$.

FIGURE 13. Measurement of angular alignment between elbow fittings.

PIN: The PIN for each hose assembly shall include its size code, length, style, protective sleeve type, and the angular alignment between the elbow fittings, as applicable.

Example: The PIN for an 8.250 inch (209.55 mm) length, style F hose assembly with a 0.500 inch (12.70 mm) tube OD, a fire protective sleeve in accordance with SAE AS1072, and a 30° between the elbow fittings shall be as follows:

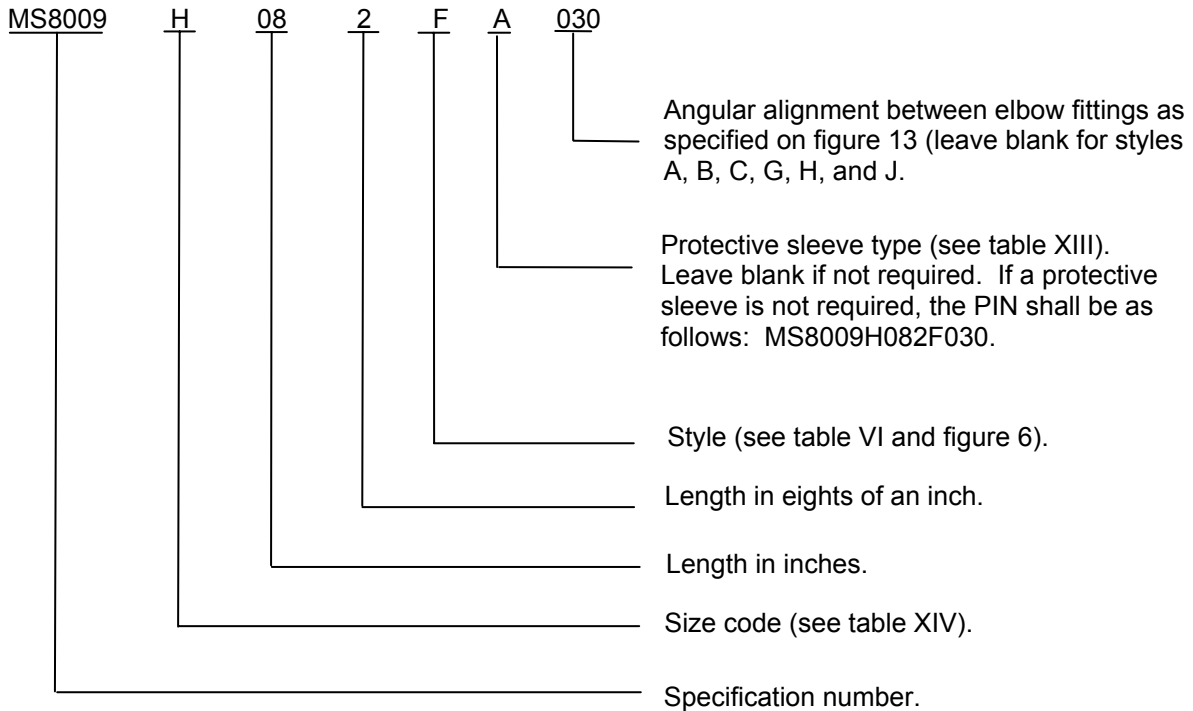

MS8009C
w/AMENDMENT 1

Amendment notations. The margins of this specification are marked with vertical lines to indicate modifications generated by this amendment. This was done as a convenience only and the Government assumes no liability whatsoever for any inaccuracies in these notations. Bidders and contractors are cautioned to evaluate the requirements of this document based on the entire content irrespective of the marginal notations.

Referenced documents. In addition to MIL-DTL-25579, this document references the following:

MS20756
SAE AS1072
SAE AS1073
SAE AS1291
SAE AS1298
SAE AS8879

CONCLUDING MATERIAL

Custodians:

Army - AV
Navy - AS
Air Force - 99
DLA - CC

Preparing activity:

DLA - CC

(Project 4720-0436-000)

Review activities:

Army - AR, AT, EA, MI
Navy - MC, SA, SH
Air Force - 70

NOTE: The activities listed above were interested in this document as of the date of this document. Since organizations and responsibilities can change, you should verify the currency of the information above using the ASSIST Online database at <http://assist.daps.dla.mil>.