

FED. SUP CLASS
5340

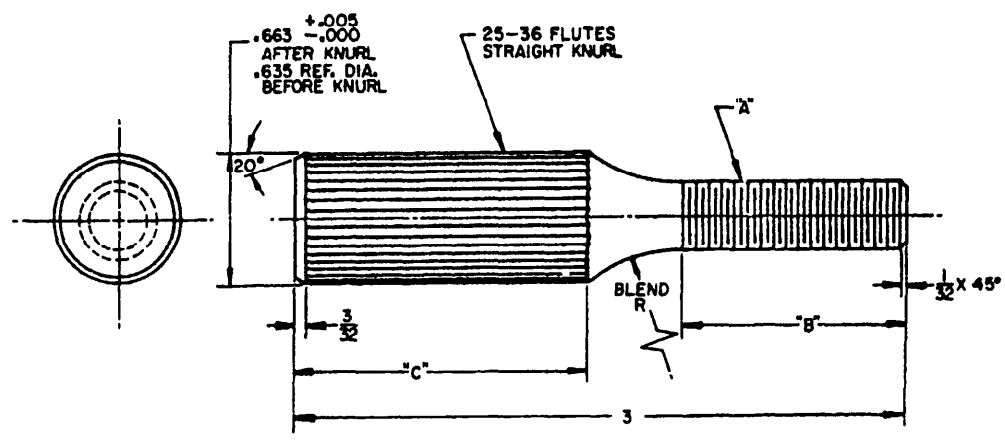

REVIEW ACTIVITY: AF-82
USER ACTIVITIES: ARMY - WC; NAVY - MC

| MS PART NO. | "A" THREAD UNF-2A | "B" THREAD LENGTH | "C" LENGTH KNURL | FORMER ARMY PART NUMBER |
|-------------|----------------------|----------------------|---------------------|----------------------------|
| MS 63043-1 | 5/16 -24 | 15/16 | 1-5/8 | 8689584 |
| MS 63043-2 | 3/8 -24 | 1-7/16 | 1-1/8 | 8741801 |
| MS 63043-3 | 1/2 -20 | 1-1/4 | 1-5/16 | NONE |
| MS 63043-4 | 5/8 -18 | 1-7/16 | 1-1/8 | NONE |

NOTES:

1. THIS CONNECTOR SHALL CONFORM TO TYPE III, STYLE 2 OF PROCUREMENT SPECIFICATION.
2. MATERIAL: COMPOSITION A OF PROCUREMENT SPECIFICATION.
3. SURFACES EXCEPT KNURLING SHALL BE FREE FROM BURRS AND SHARP EDGES.
4. THREADS SHALL BE IN ACCORDANCE WITH SCREW THREAD STANDARDS FOR FEDERAL SERVICES, HANDBOOK H2B.
5. DIMENSIONS ARE IN INCHES. UNLESS OTHERWISE SPECIFIED, TOLERANCES ARE $\pm 1/32$ ON FRACTIONS, $\pm 5^\circ$ ON ANGLES.
6. FOR DESIGN FEATURE PURPOSES, THIS STANDARD TAKES PRECEDENCE OVER PROCUREMENT DOCUMENTS REFERENCED HEREIN.
7. THIS STANDARD IS NOT INTENDED TO LIMIT CONSTRUCTION TO FEATURES OTHER THAN AS SHOWN HEREON BY DIMENSIONS, NOTATIONS, AND REFERENCED DOCUMENTS.
8. REFERENCED DOCUMENTS SHALL BE OF THE ISSUE IN EFFECT ON DATE OF INVITATIONS FOR BID.
9. MARKING SHALL CONSIST OF THE MS PART NUMBER AND MANUFACTURER'S IDENTIFICATION IN ACCORDANCE WITH MIL-STD-130.

This military standard is mandatory for use by all Departments and Agencies of the Department of Defense. Selection for all new engineering and design applications and for repetitive use shall be made from this document.

APPROVED 7 MARCH 1960 REVISED (A) 18 MAY 1965 (B) 10 DECEMBER 1969 (C) 20 AUGUST 1973

| | | |
|--|---|-------------------------------|
| P.A. ARMY-AT Other Cust AF-82 | TITLE © ROD END, THREADED-LINKAGE, RIGID | MILITARY STANDARD MS 63043 |
| PROCUREMENT SPECIFICATION MIL-C-45918 | SUPERSEDES: | SHEET 1 OF 1 |

DD FORM 1 SEP 57 672-1

coordinated

PREVIOUS EDITIONS OF THIS FORM ARE OBSOLETE.