

INCH-POUND

MIL-STD-1751A

11 December 2001

SUPERSEDING

MIL-STD-1751(USAF)

20 August 1982

**DEPARTMENT OF DEFENSE
TEST METHOD STANDARD**

**SAFETY AND PERFORMANCE TESTS
FOR THE
QUALIFICATION OF EXPLOSIVES
(HIGH EXPLOSIVES, PROPELLANTS, AND
PYROTECHNICS)**



AMSC N/A

FSG 13GP

DISTRIBUTION STATEMENT A. Approved for public release; distribution is unlimited.

MIL-STD-1751A

FOREWORD

1. This standard is approved for use by all Departments and Agencies of the Department of Defense (DOD).

2. For the purpose of this standard, the general term "explosive" refers to three distinct types of materials: high explosives, propellants, and pyrotechnics.

3. The DOD is committed to ensure that all explosives used in its weapon systems are safe to process, test, store, transport, and use. The sensitivity of explosives has a primary effect on safety and is an important factor in the vulnerability of our armed forces to self-carried munitions when operating in a combat environment. In addition, ordnance must be designed for safe demilitarization and disposal. Thus, in the design, development, and testing of munitions, consideration must always be given to provide as high a degree of safety and survivability as is reasonable. This can be accomplished by judicious selection of the explosives.

4. The Army, Navy, and Air Force individually qualify explosive materials. Data generated during testing will be submitted to assessment and approval authorities as stipulated in the implementing instructions issued by the services. Qualified explosives are considered safe for use in development programs leading to service application. Each service retains the responsibility and authority for the approval and use of explosives for its respective applications.

5. This document describes mandatory test methods and data required for qualification as well as recommended criteria for certain procedures. In some instances, several methods are presented which may be used until standardization of test hardware and procedures is achieved. When using alternative methods, comparative data on the test explosive and another commonly used reference explosive should be provided.

6. This standard is the implementing document for NATO STANAG 4170, "Principles and Methodology for the Qualification of Explosive Materials for Military Use," which has associated with it NATO Allied Ordnance Publication #7 (AOP-7), "Manual of Tests for the Qualification of Explosive Materials for Military Use." Certain test methods also implement NATO STANAGs (see 6.7).

7. Beneficial comments (recommendations, additions, deletions) and any pertinent data which may be of use in improving this document should be addressed to: OO-ALC/TIEDE, 6032 Fir Avenue, Hill AFB, UT 84056-5820, by using the Standardization Document Improvement Proposal (DD Form 1426) appearing at the end of this document or by letter.

MIL-STD-1751A

CONTENTS

PARAGRAPH	PAGE
FOREWORD	ii
1. SCOPE	1
1.1 Scope	1
1.2 Applicability	1
1.3 Classification criteria	1
1.3.1 High explosives	1
1.3.2 Propellants	1
1.3.3 Pyrotechnics	1
1.4 Test methods	1
1.4.1 Method of reference	1
2. APPLICABLE DOCUMENTS	2
2.1 General	2
2.2 Government documents	2
2.2.1 Specifications, standards, and handbooks	2
2.2.2 Other Government documents, drawings, and publications	2
2.3 Order of precedence	3
3. DEFINITIONS	4
3.1 Acronyms	4
3.2 Assessment	4
3.3 Booster explosive	4
3.4 Candidate explosive	4
3.5 Explosives	4
3.6 Final (Type) qualified explosive	4
3.7 Fuel-air explosives	4
3.8 High explosives	4
3.9 Main charge explosive	4
3.10 Mandatory data	4
3.11 Munition	5
3.12 New explosive	5
3.13 Optional data	5
3.14 Primary explosive	5
3.15 Propellants	5
3.16 Pyrotechnics	5
3.17 Qualified explosive	5
3.18 Reference comparison explosive	5
3.19 Reference standard explosive	6
3.20 Service qualification authority	6

CONTENTS

MIL-STD-1751A

PARAGRAPH	PAGE
4. GENERAL REQUIREMENTS	7
4.1 General	7
4.2 Test report	7
4.3 Material specification	7
4.4 Qualification request report	7
4.5 Test procedures and equipment	7
4.6 General qualification requirements	7
4.7 Qualification of a modified explosive composition	8
5. DETAILED REQUIREMENTS	9
5.1 Test method numbering system	9
5.1.1 Test method groups	9
5.1.2 Test method identification	9
5.1.3 Revision of test methods	9
5.2 Specific qualification tests for high explosives	9
5.2.1 Pass/fail criteria for primary explosives	9
5.2.2 Pass/fail criteria for booster explosives	10
5.2.3 Pass/fail criteria for main charge explosives	12
5.2.4 Pass/fail criteria for fuel-air explosives	13
5.3 Specific qualification tests for propellants	13
5.3.1 Solid propellants	14
5.3.2 Liquid propellants	14
5.4 Specific qualification tests for pyrotechnics	15
5.4.1 Mandatory data for pyrotechnics	15
5.5 Reporting requirements	16
5.5.1 Recommended reference standard and comparison materials for test groups 1010 through 1030	17
6. NOTES	18
6.1 Intended use	18
6.2 Issue of DODISS	18
6.3 Tailoring guidance for contractual application	18
6.4 Coordinating DOD national authority	18
6.5 Service qualification authorities	18
6.5.1 Specific responsibility of a service qualification authority	19
6.6 Subject term (keyword) listing	19
6.7 International standardization agreements	19
6.8 Changes from previous issue	20
Numerical index of test methods	21
 TABLES	
TABLE I List of mandatory data and appropriate tests for high explosives	11
TABLE II List of mandatory data and appropriate tests for propellants	13
TABLE III List of mandatory data and appropriate tests for pyrotechnics	15
TABLE IV STANAGs related to MIL-STD-1751 test groups	20

MIL-STD-1751A

1. SCOPE

1.1 **Scope.** This standard establishes tests and test methods for the qualification of explosives for use in military applications. Additional tests or characterization outside the scope of this document may be required by service qualification authorities.

1.2 **Applicability.** This standard applies to all new explosives, regardless of origin, intended for conventional applications.

1.3 **Classification criteria.** For the purpose of this standard, energetic materials are segregated into three types: high explosives, propellants, and pyrotechnics. Definitions of each are provided in section 3. Throughout this document, the general term "explosive" will be used to describe all three types. Within these groups, qualification requirements will vary based on the end use application. These specific subsets are described as follows:

1.3.1 High explosives.

- a. Primary explosives
- b. Booster explosives
- c. Main charge explosives

1.3.2 Propellants.

- a. Solid propellants
- b. Liquid propellants

1.3.3 Pyrotechnics

1.4 **Test methods.** The test methods for the qualification of explosives appear at the end of this standard. Their applicability is based on the criteria specified in sections 4 and 5 herein.

1.4.1 **Method of reference.** Test methods contained herein will be referenced in the individual document by specifying this standard with the appropriate test method number.

MIL-STD-1751A

2. APPLICABLE DOCUMENTS

2.1 **General.** The documents listed in this section are specified in sections 3, 4, and 5 of this standard. This section does not include documents cited in other sections of this standard or recommended for additional information or as examples. While every effort has been made to ensure the completeness of this list, document users are cautioned that they must meet all specified requirements documents cited in sections 3, 4, and 5 of this standard, whether or not they are listed.

2.2 Government documents.

2.2.1 **Specifications, standards, and handbooks.** The following specifications, standards, and handbooks form a part of this document to the extent specified herein. Unless otherwise specified, the issues of these documents are those listed in the issue of the Department of Defense Index of Specifications and Standards (DODISS) and supplement thereto, cited in the solicitation (see 6.2).

SPECIFICATIONS**DEPARTMENT OF DEFENSE**

MIL-DTL-398	RDX
MIL-C-401	Composition B
MIL-L-757	Lead Styphnate, Normal
MIL-L-3055	Lead Azide
MIL-T-248	Trinitrotoluene (TNT)

STANDARDS**DEPARTMENT OF DEFENSE**

MIL-STD-961	Defense Specifications
MIL-STD-2105	Hazard Assessment Tests for Non-Nuclear Munitions

(Unless otherwise indicated, copies of the above specifications and standards are available from the Standardization Document Order Desk, 700 Robbins Avenue, Bldg. 4D, Philadelphia, PA 19111-5094.)

2.2.2 **Other Government documents, drawings, and publications.** The following other Government documents, drawings, and publications form a part of this document to the extent specified herein. Unless otherwise specified, the issues are those cited in the solicitation.

PUBLICATIONS**DEPARTMENT OF THE ARMY**

TB 700-2	Department of Defense Explosives Hazard Classification Procedures [TB 700-2 is also known as NAVSEAINST 8020.8, Air Force TO 11A-1-47, and DLAR 8220.1.]
----------	--

MIL-STD-1751A

(Copies are available from the Department of Defense Explosives Safety Board (DDESB), 2461 Eisenhower Avenue, Alexandria, VA 22331-0600.)

2.3 Order of precedence. In the event of a conflict between the text of this document and the references cited herein, the text of this document takes precedence. Nothing in this document, however, supersedes applicable laws and regulations unless a specific exemption has been obtained.

MIL-STD-1751A

3. DEFINITIONS

3.1 **Acronyms.** The following acronyms are used:

HMX	Tetramethylene tetranitramine
HTPB	Hydroxy terminated polybutadiene
PETN	Pentaerythritol tetranitrate
RDX	Trimethylene trinitramine
TNT	2,4,6-Trinitrotoluene

3.2 **Assessment.** The evaluation of the properties of an explosive, the results of appropriate tests to determine its relative sensitivity to various stimuli, and its safety compared to other explosives already in service use.

3.3 **Booster explosive.** Booster explosives are compounds or formulations such as Composition CH-6 or PBXN-7 that are used to transmit and enhance the detonation reaction of the primary explosive in order to initiate the stable detonation of a main charge explosive. Materials that fall in this category include explosives used in leads, relays, detonating cords, boosters, and other components used on the warhead side of the interrupter.

3.4 **Candidate explosive.** An explosive material being evaluated in accordance with this standard.

3.5 **Explosives.** Materials capable, by chemical reaction, of producing gas at such a temperature, pressure, and rate or thermal effects (for non-gas producing materials) sufficient to cause damage to the surroundings. The term includes all solid and liquid materials identified in the United States as "high explosives," "propellants," and "pyrotechnics."

3.6 **Final (Type) qualified explosive.** An explosive that has been subjected to MIL-STD-2105 tests in a specific munition design or application and approved by the safety and qualification authorities for production and use.

3.7 **Fuel-air explosives.** Liquid slurry, gel, or solid, which exhibits explosive properties when dispersed in air. The individual substances may not be explosives. The mixtures of combustible fuels and air ordinarily require initiation by a booster explosive.

3.8 **High explosives.** Substances or mixtures which, in their application, are required to detonate. High explosives consist of primary, booster, main charge, and fuel-air explosives.

3.9 **Main charge explosive.** Main charge explosives are compounds or formulations such as Composition B, PBXN-9, or PBXN-109, that are used as the final charge in explosive train designs. These explosives, because of their insensitivity, ordinarily will require initiation by a booster explosive.

3.10 **Mandatory data.** Data required by the service qualification authority for assessing the safety and suitability of an explosive being considered in an application. Tests suitable for obtaining mandatory data are contained herein.

MIL-STD-1751A

3.11 **Munition.** A complete device (e.g., missile, shell, mine, demolition store, etc.) charged with explosives, propellants, pyrotechnics, initiating compositions or nuclear, biological or chemical material, for use in connection with offence, or defense, or training, or non-operational purposes, including those parts of weapons systems containing explosives.

3.12 **New explosive.** A new explosive encompasses:

- a. An explosive not previously qualified;
- b. Any modification to an existing explosive material changing the composition of the explosive, its material constituents, its physical properties (e.g., particle size), or the process by which the composition is made; and
- c. The application of an explosive in a role (e.g., a booster used as a main charge, or propellant used as a high explosive) for which the explosive has not already been qualified.

3.13 **Optional data.** Supplementary data that may be required by a service qualification authority for assessing the safety and suitability of an explosive being considered for a military application.

3.14 **Primary explosive.** Primary explosives are sensitive formulations or compounds such as lead azide or lead styphnate which are used to initiate detonation in high explosives. They are sensitive to heat, impact, or friction and undergo rapid reaction upon initiation. These sensitive explosives are physically separated from the booster explosive by the interrupter of either a fuze, exploder, or safe and arming device.

3.15 **Propellants.** Substances or mixtures of substances used for propelling projectiles and missiles or to generate gases used for powering auxiliary devices. When ignited, propellants burn at a controlled rate to produce quantities of gas capable of performing work. In their application, they are required not to undergo a deflagration-to-detonation transition (DDT).

3.16 **Pyrotechnics.** These are substances or mixtures of substances which, when ignited, undergo an energetic chemical reaction at a controlled rate. This reaction is intended to produce, on demand and in various combinations, specific time delays or quantities of heat, smoke, light, or infrared radiation. Exothermic alloys such as Pyrofuse are included in this category.

3.17 **Qualified explosive.** One which, in the judgment of a service qualification authority, possesses sensitivity properties that renders it safe and suitable for potential use in a particular role. An explosive is qualified when it has been formally approved by the service qualification authority for use in munitions development, product improvement, or other programs leading to eventual service application.

3.18 **Reference comparison explosive.** A Final (Type) qualified explosive with proven safety characteristics and whose safety, sensitivity, and performance properties are compared to that of a new explosive.

MIL-STD-1751A

3.19 **Reference standard explosive.** An explosive whose properties are consistent and sufficiently well-defined to enable it to be used for the calibration of test apparatus.

3.20 **Service qualification authority.** The authority designated by a service who is responsible for the qualification of explosives for that service's applications (see 6.5).

MIL-STD-1751A

4. GENERAL REQUIREMENTS

4.1 **General.** This standard provides a test regime that will provide mandatory data for assessing an explosive's safety and performance characteristics for potential use in military applications. Certain tests are required as the data is essential to the assessment process. Alternative test procedures may be approved by a service if rationale is provided to the service qualification authority indicating that the mandatory data can be accurately derived by using an alternative test procedure.

4.2 **Test report.** A test report shall be developed documenting the test results.

4.3 **Material specification.** A material specification for the explosive shall be prepared prior to qualification. This specification shall provide information on composition, ingredient particle sizes, allowable tolerances of the ingredients, requirements, tests and verification procedures. The material specification shall conform to the program-unique specification guidelines of MIL-STD-961.

4.4 **Qualification request report.** A qualification request report shall be developed.

4.5 **Test procedures and equipment.** Qualification requests presenting data obtained using test procedures or equipment not described herein shall contain a complete description of the test procedures and equipment used and comparison data on reference explosives tested in the same manner.

4.6 **General qualification requirements.** Qualification will be granted on the basis of several factors. These include:

4.6.1 Compliance with the tests for mandatory data identified in tables I, II, and III. These tests are described for primary explosives, booster explosives, main charge explosives, fuel-air explosives, propellants, and pyrotechnics.

4.6.2 Comparison of test results with data obtained on reference comparison explosive materials. Since variations in results exist between facilities using the same apparatus, new explosives must be compared to two reference comparison explosives previously qualified for that particular application. If possible, the two reference comparison explosives should bracket the sensitivity of the explosive to be qualified, i.e., one should be more sensitive and one less sensitive than the explosive under consideration. This will give an indication of the range of values covered by explosives of a given class (primary, booster, main charge, etc.) Reference standard explosives shall also be used where specified in the Test Methods, and may serve as one or both of the reference comparison explosives.

4.6.3 Information regarding the processability and producibility of the explosive composition.

4.6.4 A material specification for the explosive (see 4.3).

4.6.5 The assignment of DOD interim or final hazard classification for the packaged material, if the substance is to be shipped. Testing shall be conducted in accordance with TB 700-2. Test Methods previously included in MIL-STD-1751 solely because of requirements for hazard classification purposes (Test Groups 1050 and 1080) have been omitted from the current revision of this document.

4.6.6 Toxicity Evaluation.

a. Evaluation of the toxicity of an explosive must be performed as part of the qualification process. This includes assessments of the ingredients, combustion products, and by-products of the processing of the explosive. Support in the evaluation of toxicity is available from the

MIL-STD-1751A

Operational Toxicology Branch of the Air Force Research Laboratory Deployment and Sustainment Division, at Wright Patterson AFB.

- b. The breadth of test arrangements and procedures and approaches to the analysis of the data is too great to be captured in a Test Method. The most recent editions of the references listed below provide guidance on the evaluation of toxicity and representative data.
- (a) *Registry of Toxic Effects of Chemical Substances* U. S. Dept. of Health and Human Services, National Institute for Occupational Safety and Health (NIOSH), Washington, DC: U. S. Government Printing Office.
 - (b) *IARC Monographs on the Evaluation of the Carcinogenic Risk of Chemicals to Humans*, World Health Organization.(Continuing Series).
 - (c) *Occupational Diseases. A Guide to Their Recognition*, U. S. Dept. of Health and Human Services, National Institute for Occupational Safety and Health (NIOSH), Washington, DC: U. S. Government Printing Office.
 - (d) *Toxic and Hazardous Industrial Chemicals Safety Manual*, International Technical Information Institute, Tokyo, Japan.
 - (e) *Sax's Dangerous Properties of Industrial Materials, 10th Edition*, Richard J. Lewis, Sr., ed.

4.6.7 Performance of additional tests deemed appropriate by the service qualification authority. These may include aging studies, chemical compatibility of the explosive with materials with which it may come in contact, high velocity impact tests, etc.

4.7 Qualification of a modified explosive composition. Slight modifications to the composition of a qualified explosive could have a significant effect on the sensitivity of the material. As a result, any changes to the formulation of a qualified material, such as particle size adjustments or changes in allowable tolerances, shall be reviewed by the appropriate service authority so that a determination can be made as to whether the new material must be requalified. This review shall occur prior to the incorporation of the explosive into any weapon system.

MIL-STD-1751A

5. DETAILED REQUIREMENTS

5.1 **Test method numbering system.** The test methods described at the end of this standard are designated by numbers assigned in accordance with the following system.

5.1.1 **Test method groups.** Test methods are arranged in groups according to qualification data category. These groups are identified numerically below. Test Groups that have been deleted from a previous edition are shown as Unused.

<u>Test Group</u>	<u>Qualification Data Category</u>
1010	Impact sensitivity
1020	Friction sensitivity
1030	Electrostatic discharge sensitivity
1040	Explosive shock sensitivity
1050	Unused
1060	Stability (Constant Temperature)
1070	Stability (Variable Temperature)
1080	Unused
1090	Critical diameter
1100	Detonation velocity
1110	Unused
1120	Flash point
1130	Detonability of fuel-air explosives
1140	Minimum pressure for vapor ignition
1150	Ignition sensitivity

5.1.2 **Test method identification.** Test methods in each group are identified in increasing numerical order. For example, the first test method in Group 1010 would be Test Method 1011; the first test method in Group 1100 would be Test Method 1101. A numerical index of test methods appears at the beginning of the test method section herein.

5.2 **Specific qualification tests for high explosives.** Tests conducted to obtain mandatory data for the qualification of high explosives are listed in Table I. For each stimulus, test methods are listed at the end of section 6 for primary, booster, main charge, and fuel-air explosives. Even though multiple tests are listed for some Test Groups, it is only necessary to employ one test method for each unless otherwise directed by the service qualification authority.

5.2.1 **Pass/fail criteria for primary explosives.** Advisory criteria are provided for some data requirements of table I. Failure to meet any or all the advisory criteria shall normally be a cause for rejection of the explosive by the service qualification authority. The following data are required:

a. Impact sensitivity. Data shall be compared to normal lead styphnate conforming to MIL-L-757 and dextrinated lead azide conforming to Type I of MIL-L-3055, measured on the same test apparatus using a Group 1010 test method. Test Method 1016 is preferred

MIL-STD-1751A

b. Friction sensitivity. Data shall be compared to normal lead styphnate conforming to MIL-L-757 and dextrinated lead azide conforming to Type I of MIL-L-3055, measured on the same test apparatus using a Group 1020 test method. If Test Method 1024 is used, the smaller BAM apparatus is preferred.

c. Electrostatic sensitivity. Data shall be compared to normal lead styphnate conforming to MIL-L-757 and dextrinated lead azide conforming to Type I of MIL-L-3055, measured on the same test apparatus using a Group 1030 test method.

d. Stability (Constant Temperature). Advisory criterion of no more than 2 ml gas evolved/gram of explosive/48 hours at 100 °C when using Test Method 1061 or 1063.

e. Self-heating. Although primary explosive charge sizes are not large enough to warrant a self-heating analysis (Test Method 1074), the minimum temperature for exotherm onset should be determined using Test Method 1071 or 1072.

f. Compatibility. The interaction of the candidate explosive with common materials (e.g., metals, adhesives, acids, bases) with which it may come into contact shall be assessed by comparison of the results for the candidate explosive in a 1:1 mixture with the material being tested for compatibility with the results for the candidate explosive alone (section 5.2.1.d or 5.2.1.e) obtained using Group 1060 or 1070 test methods. Advisory criterion when using Test Method 1071 or 1072 is a change of no more than 10°C in the temperature of the exotherm peak temperature, measured at a heating rate of 10°C/minute or less.

g. Ignition Sensitivity. No advisory criterion when using Test Method 1151.

5.2.2 Pass/fail criteria for booster explosives. Booster explosives are allowed beyond the fuze interrupter of warhead safety and arming devices. Failure to meet any of the required criteria shall normally be cause for rejection of the explosive by the service qualification authority. The following data are required:

a. Impact sensitivity. The candidate explosive passes the Impact Sensitivity Test if it is shown to be no more sensitive than a Type I or II, Class 5 RDX standard conforming to MIL-DTL-398, measured contemporaneously with the candidate explosive by one of the Group 1010 test methods.

b. Friction sensitivity. The candidate explosive passes the friction sensitivity test if it is shown to be no more sensitive than a Type I or II, Class 5 RDX standard conforming to MIL-DTL-398, measured contemporaneously with the candidate explosive by one of the Group 1020 test methods.

c. Electrostatic sensitivity. The candidate explosive passes the electrostatic sensitivity test if it is shown to be no more sensitive than a Type I or II, Class 1 or Class 5 RDX standard conforming to MIL-DTL-398, measured contemporaneously with the candidate explosive by one of the Group 1030 test methods.

MIL-STD-1751A

TABLE I. List of mandatory data and appropriate tests for high explosives.

Mandatory Data / Test	Primary	Booster	Main Charge
Impact sensitivity	x	x	x
Friction sensitivity	x	x	x
Electrostatic sensitivity	x	x	x
Stability (Constant Temperature)	x	x	x
Self-heating	x	x	x
Compatibility	x	x	x
Detonation velocity	—	x	x
Critical Diameter	—	x	x
Shock sensitivity	—	x	x
Hot Wire Ignition	x	—	—
Exudation and Growth	—	x	x

d. Stability (Constant Temperature). Advisory criterion of no more than 2 ml gas evolved/gram of explosive/48 hours at 100°C when using Methods 1061 and 1063, or 4 ml gas evolved/gram of explosive/22 hours at 120°C when using Test Method 1062.

e. Self-heating. Self-heating is assessed either experimentally or by calculation.

(1) Test Method 1074 may be used to estimate the critical temperature. Advisory criterion is a calculated critical temperature of no less than 180°F for 500 days for a given geometry and mass. Data required for this calculation are obtained by Test Method 1071 or 1072.

(2) Method 1075 may be used to determine experimentally the self-heating temperature and severity of reaction for melt-cast compounds or formulations for unconfined, spherical geometry.

f. Compatibility. The interaction of the candidate explosive with common materials (e.g., metals, adhesives, acids, bases) with which it may come into contact shall be assessed by comparison of the results for the candidate explosive in a 1:1 mixture with the material being tested for compatibility with the results for the candidate explosive alone (section 5.2.2.d or 5.2.2.e) obtained using Group 1060 or 1070 test methods. Advisory criterion when using Test Method 1071 or 1072 is a change of no more than 10 C in the temperature of the exotherm peak temperature, measured at a heating rate of 10 C/minute or less.

g. Detonation velocity. No pass/fail criterion assigned. Test Method 1101 is conducted only to ensure that the explosive will detonate.

h. Critical diameter. For information purposes. No pass/fail criterion assigned. Group 1090 test methods shall be used.

MIL-STD-1751A

i. Shock sensitivity. The test shall be performed in accordance with Test Method 1042. Twenty samples are fired using 4.0-decibang attenuators which corresponds to an input pressure of 12.1 kbar. The explosive passes if there are no detonations in 20 consecutive trials. Any reaction causing a dent of 0.002 inch or more is considered a detonation.

j. Exudation and Growth.

5.2.3 Pass/fail criteria for main charge explosives. No mandatory pass or fail criteria are assigned. Advisory criteria are provided for several measures of sensitivity. Failure to meet any or all of the advisory criteria shall normally be cause for rejection of the explosive by the service qualification authority. An exception to this preference for rejection should be made for explosives containing ammonium perchlorate. Such materials tend to have sensitivities as determined by these test methods that would lead to rejection, but their overall safety may not be adequately reflected by these measures. A thorough appraisal of all relevant safety data should be made before any explosive is rejected. The following data are required:

a. Impact sensitivity. The impact sensitivity shall be compared both to a Type I or II, Class 5 RDX conforming to MIL-DTL-398, measured contemporaneously with the candidate explosive, and to a qualified main charge explosive by one of the Group 1010 test methods. Advisory criterion of sensitivity no more than that of Comp B.

b. Friction sensitivity. The friction sensitivity shall be compared both to a Type I or II, Class 5 RDX conforming to MIL-DTL-398, measured contemporaneously with the candidate explosive, and to a qualified main charge explosive by one of the Group 1020 test methods. Advisory criterion of sensitivity no more than that of Comp B.

c. Electrostatic sensitivity. The electrostatic sensitivity shall be compared both to a Type I or II, Class 1 or Class 5 RDX conforming to MIL-DTL-398, measured contemporaneously with the candidate explosive, and to a qualified main charge explosive by one of the Group 1030 test methods. Advisory criterion of sensitivity no more than that of Comp B.

d. Stability (Constant Temperature). Advisory criterion of no more than 2 ml gas evolved/gram of explosive/48 hours at 100°C when using Methods 1061 and 1063, or 4 ml gas evolved/gram of explosive/22 hours at 120°C when using Test Method 1062.

e. Self-heating. Self-heating is assessed either experimentally or by calculation.

(1) Test Method 1074 may be used to estimate the critical temperature. Advisory criterion is a calculated critical temperature of no less than 180°F for 500 days for a given geometry and mass. Data required for this calculation are obtained by Test Method 1071 or 1072.

(2) Test Method 1075 may be used to determine experimentally the self-heating temperature and severity of reaction for melt-cast compounds or formulations for unconfined, spherical geometry.

f. Compatibility. The interaction of the candidate explosive with common materials (e.g., metals, adhesives, acids, bases) with which it may come into contact shall be assessed by

MIL-STD-1751A

comparison of the results for the candidate explosive in a 1:1 mixture with the material being tested for compatibility with the results for the candidate explosive alone (section 5.2.3.d or 5.2.3.e) obtained using Group 1060 or 1070 test methods. Advisory criterion when using Test Method 1071 or 1072 is a change of no more than 10°C in the temperature of the exotherm peak temperature, measured at a heating rate of 10°C/minute or less.

- g. Detonation velocity. For information purposes. Test Method 1101 shall be used.
- h. Critical diameter. For information purposes. Group 1090 test methods shall be used.
- i. Shock sensitivity. The shock sensitivity shall be assessed using one of the Group 1040 test methods. Advisory criterion is a 50 percent point no more than that of any type or grade of Composition B, conforming to MIL-C-401, cast at a density of 1.69 g/cm³.
- j. Exudation and Growth

5.2.4 Pass/fail criteria for fuel-air explosives. Because of the nature of these materials, qualification is generally concurrent with Final (Type) qualification. Specific data requirements for qualification will be assigned on a case-by-case basis by the service qualification authority. No pass or fail criteria are assigned. Qualification, however, is still required for the conventional explosives used in fuel-air weapons.

TABLE II. List of mandatory data and appropriate tests for propellants.

Mandatory Data / Test	Solid	Liquid
Impact sensitivity	x	x
Friction sensitivity	x	x
Electrostatic sensitivity	x	x
Stability (Constant Temperature)	x	x
Self-heating	x	x
Compatibility	x	x
Shock sensitivity (gap test)	x	x
Flash point	—	x
Minimum pressure for vapor ignition	—	x
Critical diameter	x	—

5.3 Specific qualification tests for propellants. Tests conducted to obtain mandatory data for the qualification of propellants are listed in Table II. For each stimulus, test methods are listed at the end of section 6 for solid and liquid propellants. Even though multiple tests are listed for some Test Groups, it is only necessary to use one test method for each unless otherwise directed by the service qualification authority. Propellants are generally qualified in accordance with the requirements of a specific

MIL-STD-1751A

application. The final formulation is generally established late in the development cycle of the end item and requests for qualification may be concurrent with requests for Final (Type) qualification.

5.3.1 **Solid propellants.** The following criteria are recommended:

a. Impact sensitivity. The impact sensitivity shall be compared both to a Type I or II, Class 5 RDX conforming to MIL-DTL-398, measured contemporaneously with the candidate explosive by one of the Group 1010 test methods, and to a qualified propellant intended for a similar application. Advisory criterion of sensitivity no more than that of the reference comparison propellant.

b. Friction sensitivity. The friction sensitivity shall be compared both to a Type I or II, Class 5 RDX conforming to MIL-DTL-398, measured contemporaneously with the candidate explosive by one of the Group 1020 test methods, and to a qualified propellant intended for a similar application. Advisory criterion of sensitivity no more than that of the reference comparison propellant.

c. Electrostatic sensitivity. The electrostatic sensitivity shall be compared both to a Type I or II, Class 1 or Class 5 RDX conforming to MIL-DTL-398, measured contemporaneously with the candidate explosive by one of the Group 1030 test methods, and to a qualified propellant intended for a similar application. Advisory criterion of sensitivity no more than that of the reference comparison propellant.

d. Stability (Constant Temperature). Advisory criterion of no more than 2 ml gas evolved/gram of propellant/40 hours at 100°C when using Methods 1061 and 1063.

e. Self-heating. Self-heating is assessed either experimentally or by calculation.
(1) Test Method 1074 may be used to estimate the critical temperature. Data required for this calculation are obtained by Test Method 1071 or 1072.
(2) <UN Test Series 3-c>

f. Compatibility. The interaction of the candidate explosive with common materials (e.g., metals, adhesives, acids, bases) with which it may come into contact shall be assessed by comparison of the results for the candidate propellant in a 1:1 mixture with the material being tested for compatibility with the results for the candidate propellant alone (section 5.3.1.d or 5.3.1.e) obtained using Group 1060 or 1070 test methods. Advisory criterion when using Test Method 1071 or 1072 is a change of no more than 10°C in the temperature of the exotherm peak temperature, measured at a heating rate of 10°C/minute or less.

g. Shock sensitivity. The shock sensitivity shall be assessed using one of the Group 1040 test methods.

h. Critical diameter. The critical diameter shall be assessed using one of the Group 1090 test methods.

5.3.2 **Liquid propellants.** Liquid propellants are generally qualified in accordance with a specific application or end use. This class of explosives includes thixotropic gels and mono- or multi-component liquid propellants used in guns, rocket motors, or other military applications. Qualification

MIL-STD-1751A

requests are generally submitted concurrently with the request for Final (Type) qualification. No pass/fail criteria are assigned and no advisory criteria are provided. The following data are required to evaluate the overall safety characteristics:

a. Impact sensitivity. The impact sensitivity shall be compared to that of n-propyl nitrate, measured contemporaneously with the candidate propellant, by one of the Group 1010 test methods that can be used with liquids..

b. Friction sensitivity. The friction sensitivity shall be compared to that of n-propyl nitrate, measured contemporaneously with the candidate propellant, by one of the Group 1020 test methods that can be used with liquids.

c. Electrostatic sensitivity. The electrostatic sensitivity shall be compared to that of n-propyl nitrate, measured contemporaneously with the candidate propellant, by one of the Group 1020 test methods that can be used with liquids.

d. Shock sensitivity. The shock sensitivity shall be assessed using one of the Group 1040 test methods.

e. Flash point. For information purposes. No advisory criterion when using Test Method 1121. Test Method 1073 may be used for liquid propellants of low volatility.

f. Minimum pressure for vapor phase ignition as verified by using Test Method 1141.

5.4 Specific qualification tests for pyrotechnics. Tests conducted to obtain mandatory data for the qualification of pyrotechnics are listed in Table III. For each stimulus, test methods are listed at the end of section 6. Even though multiple tests are listed for some Test Groups, it is only necessary to use one test method for each group unless otherwise directed by the service qualification authority.

TABLE III. List of mandatory data and appropriate tests for pyrotechnics.

Mandatory Data / Test	Pyrotechnics
Impact sensitivity	x
Friction sensitivity	x
Electrostatic sensitivity	x
Stability (Constant Temperature)	x
Self-heating	x
Compatibility	x

5.4.1 Mandatory data for pyrotechnics. No pass-fail criteria are specified; however, advisory criteria are provided for some stimuli. The following data are required:

a. Impact sensitivity. The impact sensitivity shall be compared to that of both a Type I or II, Class 5 RDX standard conforming to MIL-DTL-398, measured contemporaneously with the candidate

MIL-STD-1751A

pyrotechnic by one of the Group 1010 test methods, and that of a qualified pyrotechnic material intended for use in a similar application. Advisory criterion of sensitivity no more than that of the reference comparison pyrotechnic.

b. Friction sensitivity. The friction sensitivity shall be compared to both a Type I or II, Class 5 RDX conforming to MIL-DTL-398, measured contemporaneously with the candidate pyrotechnic by one of the Group 1020 test methods, and a qualified pyrotechnic intended for use in a similar application. Advisory criterion of sensitivity no more than that of the reference comparison pyrotechnic.

c. Electrostatic sensitivity. The electrostatic sensitivity shall be compared to both a Type I or II, Class 1 or Class 5 RDX conforming to MIL-DTL-398, measured contemporaneously with the candidate explosive by one of the Group 1030 test methods, and a qualified pyrotechnic intended for using a similar application. Advisory criterion of sensitivity no more than that of the reference comparison pyrotechnic.

d. Stability (Constant Temperature). Advisory criterion of no more than 2 ml gas evolved/gram of explosive/48 hours at 100°C when using Methods 1061 and 1063, or 4 ml gas evolved/gram of explosive/22 hours at 120°C when using Test Method 1062.

e. Self-heating. Self-heating is assessed by calculation. Test Method 1074 may be used to estimate the critical temperature. Data required for this calculation are obtained by Test Method 1071 or 1072.

f. Compatibility. The interaction of the candidate explosive with common materials (e.g.,metals, adhesives, acids, bases) with which it may come into contact shall be assessed by comparison of the results for the candidate explosive in a 1:1 mixture with the material being tested for compatibility with the results for the candidate explosive alone (section 5.4.1.d) obtained using Group 1060 or 1070 test methods. Advisory criterion when using Test Method 1071 or 1072 is a change of no more than 10°C in the temperature of the exotherm peak temperature, measured at a heating rate of 10°C/minute or less.

5.5 Reporting requirements. All results reported for the tests conducted under the Test Methods described in this document shall include the following information regarding the material for which the results were obtained and the conditions of testing:

- a. Name of the material being tested
- b. Source of the material including
 - (1) manufacturer
 - (2) date of manufacture
 - (3) lot # or other specific identifier
- c. Material Specifics
 - (1) Composition
 - (2) Particle sizes or classes used, or particle size distribution (depending on the nature of the material)
- d. State of the sample at the time of test
 - (1) Density and % theoretical maximum density

MIL-STD-1751A

- (2) Sample dimensions and mass
- e. Statement about whether the material used in the testing was:
 - (1) a powder used as received
 - (2) ground before use
 - (3) sieved before use (if so, state what fraction was used)
 - (4) a single piece or multiple pieces
 - (5) a sample removed from a sheet or slab of cast material
 - (6) other physical condition
- f. Environmental conditions at time of test
 - (1) temperature
 - (2) % RH
- g. pre-test conditioning of the sample
- h. Test Method Number (e.g., Method 1011) and date test was conducted
- i. organization that conducted the test
- j. Specific information about the test
 - (1) Criteria for go/no-go
 - (2) Parameters for the specific test method (see test methods for details)
- k. Reference standard materials. For each reference standard, give the information specified in items 5.5.a through 5.5.e above.
- l. Date on which test was conducted on the standard

5.5.1 Recommended reference standard and comparison materials for test groups 1010 through 1030. The day-to-day variations in the small-scale tests in Groups 1010 through 1030 make it necessary to report results for reference standard materials that were collected contemporaneously with the material under study for qualification. It is recommended that the reference materials chosen include at least one pure material (Class 5 RDX, the standard of comparison for booster and main charge explosives), and another material similar in processing or handling technique to the type of material being tested. The frequency of testing of the standards should be determined by the reproducibility of the reported values for the standards at each laboratory, but should be conducted within at least 30 days of the test conducted for the material under study. Some examples are:

- a. Powders: Class 1 or Class 5 RDX, Class V HMX,
- b. Pressed materials: molding powder such as Composition A-5, Composition A-3, Composition CH-6
- c. Melt-cast material: TNT, or a TNT-based material such as Composition B, or Octol
- d. Cast-cured material: a rubbery PBX or composite propellant, such as PBXN-110 or other HMX/HTPB PBX at 88% solids loading
- e. Liquid: n-propyl nitrate

MIL-STD-1751A

6. NOTES

(This section contains information of a general or explanatory nature that may be helpful but is not mandatory.)

6.1 Intended use. The data generated from the test methods presented herein will be used to assess an explosive's characteristics. This assessment will aid in determining whether an explosive should be qualified for use by the military.

6.2 Issue of DODISS. When this standard is used in acquisition, the applicable issue of the DODISS must be cited in the solicitation (see 2.2.1).

6.3 Tailoring guidance for contractual application. To ensure proper application, invitation for bids, requests for proposals, and contractual statements of work should tailor the requirements in sections 4 and 5 of this standard to exclude any unnecessary requirements. Contractual documents should specify:

- a. Whether a report documenting the test results is required (see 4.2)
- b. Whether a material specification is required (see 4.3)
- c. Whether a qualification request report is required (see 4.4)
- d. Whether test procedures and equipment must be described (see 4.5).

6.4 Coordinating DOD national authority. The coordinating DOD national authority for explosive technology and the implementation of this standard is:

Office of the Undersecretary of Defense (Acquisition, Technology, and Logistics)/
Strategic and Tactical Systems, Munitions
Room 3B 1060
3090 Defense Pentagon
Washington, D.C. 20301-3090

6.5 Service qualification authorities. Each military service has identified the authority responsible for the qualification of explosives, ensuring the requirements herein are met, and maintaining the repository for all qualified explosives. The specific authorities for each service are:

Air Force: For explosives developed for use in AF Munitions:

Executive Secretary
USAF Nonnuclear Munitions Safety Board
Air Armaments Center
1001 N. 2nd St., Suite 366
Eglin Air Force Base, FL 32542-6838

Navy/Marine Corps:

Commander
Naval Ordnance Safety and Security Activity
23 Strauss Avenue
Bldg. D-323
Indian Head, Maryland 20640-5035

MIL-STD-1751A

Army: For explosives developed by the U.S. Army Tank-Automotive and Armaments Command:

Commander
TACOM-ARDEC
ATTN: AMSTA-AR-WEE
Picatinny Arsenal, NJ 07806-5000

For explosives developed by the U.S. Army Missile Command:

Commander
U.S. Army Aviation and Missile Command
Redstone Arsenal, AL 35898-5249

6.5.1 Specific responsibility of a service qualification authority. Each service qualification authority is responsible for the following:

a. Defining the tests required to determine the safety and performance characteristics of explosives used by that service and the associated requirements for qualification.

b. Receiving and assessing data for qualification generated by the various technical organizations involved in the development of explosive materials. Determines whether an explosive should be qualified based on test results indicating whether that material is safe and suitable for consideration in a particular role. Ensures that all explosives incorporated in fielded weapon systems are qualified for use.

c. Qualifying explosives by issuing the appropriate documentation and promulgating this information into the various activities.

d. Maintaining records of all qualified explosives including the data on which qualification was based and for providing such information to other services for their consideration in qualification.

e. Determining whether explosives qualified by other services are suitable for use in their own applications.

6.6 Subject term (keyword) listing.

Primary explosives
Booster explosives
Main charge explosives
Solid propellants
Liquid propellants

6.7 International standardization agreements. MIL-STD-1751 implements NATO STANAG 4170, "Principles and Methodology for the Qualification of Explosive Materials for Military Use." When change notice, revision, or cancellation of this standard is proposed that will modify the international agreement concerned, the preparing activity will take appropriate action through international standardization channels, including departmental standardization offices, to change the agreement or

MIL-STD-1751A

make other appropriate accommodations. Other NATO STANAGs which provide guidance relative to the various test groups are identified in Table IV.

Table IV. STANAGs related to mil-std-1751 test groups

Test Group	NATO STANAG
1010 - Impact Sensitivity	4489
1020 - Friction Sensitivity	4487
1030 - Electrostatic Discharge Sensitivity	4490
1040 - Explosive Shock Sensitivity	4488
1060 - Thermal Stability (Constant Temperature)	4556
1070 - Self-heating	4515/4491

6.8 Changes from previous issue. Marginal notations are not used in this revision to identify changes with respect to the previous issue due to the extensiveness of the changes.

Custodians:
 Army - AR
 Navy - OS
 Air Force - 99

Preparing activity:
 Navy - OS
 (Project 13GP-0076)

MIL-STD-1751A

Numerical index of test methods.

Test Method #	Date	Title
Group 1010 Impact sensitivity		
1011		Impact test (laboratory scale) — Bureau of Explosives apparatus
1012		Impact sensitivity test — ERL (Explosives Research Lab)/ Bruceton apparatus
1013		Impact test (laboratory scale) — Los Alamos National Laboratory
1014		Impact test (drop hammer) — Bureau of Mines
1015		BAM impact test apparatus
1016	7/25/01	Ball drop impact test
1017	7/25/01	Olin-Mathieson impact test
Group 1020 Friction sensitivity		
1021		Friction sensitivity — ABL sliding friction test
1022		Friction, steel/fiber shoe test
1023		Roto-friction test
1024		BAM friction test
Group 1030 Electrostatic discharge sensitivity		
1031		Electrostatic discharge sensitivity test — NSWC method
1032		Electrostatic discharge sensitivity test - ARDEC (Picatinny Arsenal) method
1033		Electrostatic discharge sensitivity test - NAWC method
1034		Electrostatic discharge sensitivity test — large scale
Group 1040 Explosive shock sensitivity		
1041		Explosive shock sensitivity test - NOL large scale gap test (LSGT)
1042		Explosive shock sensitivity test - NOL small scale gap test (SSGT)
1043		Explosive shock sensitivity test - expanded large scale gap test (ELSGT)
1044		Explosive shock sensitivity test - super large scale gap test
1045		Explosive shock sensitivity test - insensitive high explosive (IHE) gap test
1046		Explosive shock sensitivity test - wedge test
Group 1050 Unused		

MIL-STD-1751A

Numerical index of test methods (continued).

Test Method #	Date	Title
Group 1060 Thermal Stability (Constant Temperature)		
1061		Vacuum thermal stability (VTS)
1062		Chemical Reactivity Test
1063	3/9/01	Modified Vacuum Thermal Stability Test (MVTS)
Group 1070 Self-heating: Thermal Stability (Variable Temperature)		
1071		Differential thermal analysis (DTA)
1072		Differential scanning calorimetry (DSC)
1073		Thermogravimetric analysis (TGA)
1074		Determination of critical temperature and self-heating properties
1075	3/9/01	One-Liter Cookoff Test
Group 1080 Unused		
Group 1090 Critical diameter		
1091		Critical diameter
1092		Very small critical diameter
Group 1100 Detonation velocity		
1101		Detonation velocity test
Group 1110 Unused		
Group 1120 Flash point		
1121		Flash point — liquid explosives
Group 1130 Detonability of fuel-air explosives		
1131		Detonability of fuel-air explosives
Group 1140 Minimum pressure for vapor ignition		
1141		Minimum pressure for vapor phase ignition — liquid propellants
Group 1150 Ignition sensitivity		
1151		Hot-wire ignition
Group 1160 Exudation and Growth		
1161	7/25/01	Exudation
1162	7/25/01	Growth

MIL-STD-1751A

Notes about test methods:

1. **Mandatory Data.** The test methods in this table are deemed satisfactory for obtaining the mandatory data required by the service qualification authorities for qualifying explosives.
2. **Test Equipment Variations.** Test equipment used to obtain the mandatory data vary, and data for specific stimuli obtained at different sites are expected to vary as well. Thus it is necessary to obtain data on reference comparison or reference standard explosives (see 3.18 and 3.19) at the same site and under the same test conditions.

MIL-STD-1751A

Group 1010
Test Methods
Impact Sensitivity

MIL-STD-1751A

Method 1011**Impact Test (Laboratory Scale) - Bureau of Explosives Apparatus****1. TYPE OF TEST:** Impact

2. PURPOSE: This test determines the sensitivity to a normal impact of explosives in powder and liquid form.

3. BACKGROUND: Both solid and liquid materials may be tested using this apparatus although the sample assemblies vary for the two. The test setup and assembly is identical to the one described in Test Series 3a(i) for the United Nations classification of explosive substances for transportation as described in reference (a).

4. TEST ARRANGEMENT:

4.1 Solid materials: The test apparatus, as shown in Figure 1, consists of an 8-lb weight suspended between two cylindrical guide rods. The weight is allowed to fall freely from a maximum height of 33 inches (\approx 84 cm) onto a plunger and plug assembly which is in contact with the explosive sample. The explosive sample is confined in a cylindrical case of 0.20 ± 0.02 inch in diameter by 0.10 ± 0.02 inch in length. This case is designed to allow free movement of the plug and plunger. The confined sample rests on a die and anvil assembly. The die, casing, anvil, plug and plunger are all fabricated of tool steel, hardened to 50-55 HRC. Mating surfaces and those in contact with the explosive sample are ground to a finish of 0.8 microns (32 μ inches).

5. PROCEDURE:

5.1 For solid materials: A 10-mg sample is loaded onto the die. Powdered samples are used in bulk form. Solid samples can either be tested as a solid wafer or ground into a powder. When reporting results, the final form of the test sample should be reported. The anvil and die are placed in the housing and the casing screwed down over them. The plug and plunger are then inserted on top of the sample. The drop weight is then released from a predetermined height. A measurement is considered positive if either an audible report or flame is observed. A minimum of 25 tests are run to determine the 50% point using a Bruceton procedure.

5.2 For liquid materials: One drop of the test liquid is placed in the copper cup which has been fixed in the cup positioning block. The striker housing is placed over the cup and into the positioning block. The end of the striker should fit part of the way into the cup, but the positioning block should prevent the striker from actually touching the liquid in the cup. (Friction will hold the cup on the end of the striker when the housing is raised from the positioning block.) The striker housing is then screwed into the anvil housing. The bottom of the copper cup should just touch the anvil when the striker housing is screwed into place. This entire assembly is then placed in the same mechanism used for solid materials. A measurement is considered positive if either an audible report, smoke, or flame is observed. A minimum of 25 tests are run to determine the 50% point using a Bruceton procedure.

MIL-STD-1751A

6. RESULTS AND DATA:

6.1 The following information shall be reported for this test:

- a. Sample weight
- b. Method of endpoint detection, such as:
 - i. Sound – Microphone/recorder Arrangement, Ear
 - ii. Go/no Go determination methodology
 - iii. Smell
 - iv. Sight – Flash, Smoke, Etc.
 - v. All or combination of above
- c. Number of drops per test
- d. Number of test replications
- e. Method of data analysis
- f. Experimental material result with standard deviation
- g. Reference material result with standard deviation

6.2 Typical test data obtained on this apparatus is shown below:

Test Sample	(H ₅₀)* Drop Height	
	(cm)	(in.)
HMX, Grade B (12μ)	7.9	3.1
RDX (850μ - 30%; 300μ - 30%; 150μ - 15%; 75μ - 25%)	9.4	3.7
HNS-II	15.8	6.2

* H₅₀ is the value (from the Bruceton Up and Down Method) at which 50% of the samples react.

7. SUPPLEMENTARY INFORMATION:

7.1 References (a) and (b) provide specific pass-fail criteria for transportation.

7.2 A more detailed description of the test apparatus may be obtained from reference (c)

8. NATIONAL REFERENCES:

a. *Recommendations on the Transport of Dangerous Goods, Tests and Criteria*, United Nations, New York.

b. TB 700-2, *Department of Defense Explosives Hazard Classification Procedures*. Also known as NAVSEAINST 8020.8B, Air Force TO 11A-1-47, and DLAR 8220.1.

c. Walker, G. R., Whitbread, E. G., and Hornig, D. C., ed. *Manual of Sensitiveness Tests*, Valcartier, Quebec, Canada: Canadian Armament Research and Development Establishment. Published for Tripartite Technical Cooperation Program (TTCP), Panel 0-2 (Explosives), Working Group on Sensitiveness, February 1966, pp. 46-50.

MIL-STD-1751A

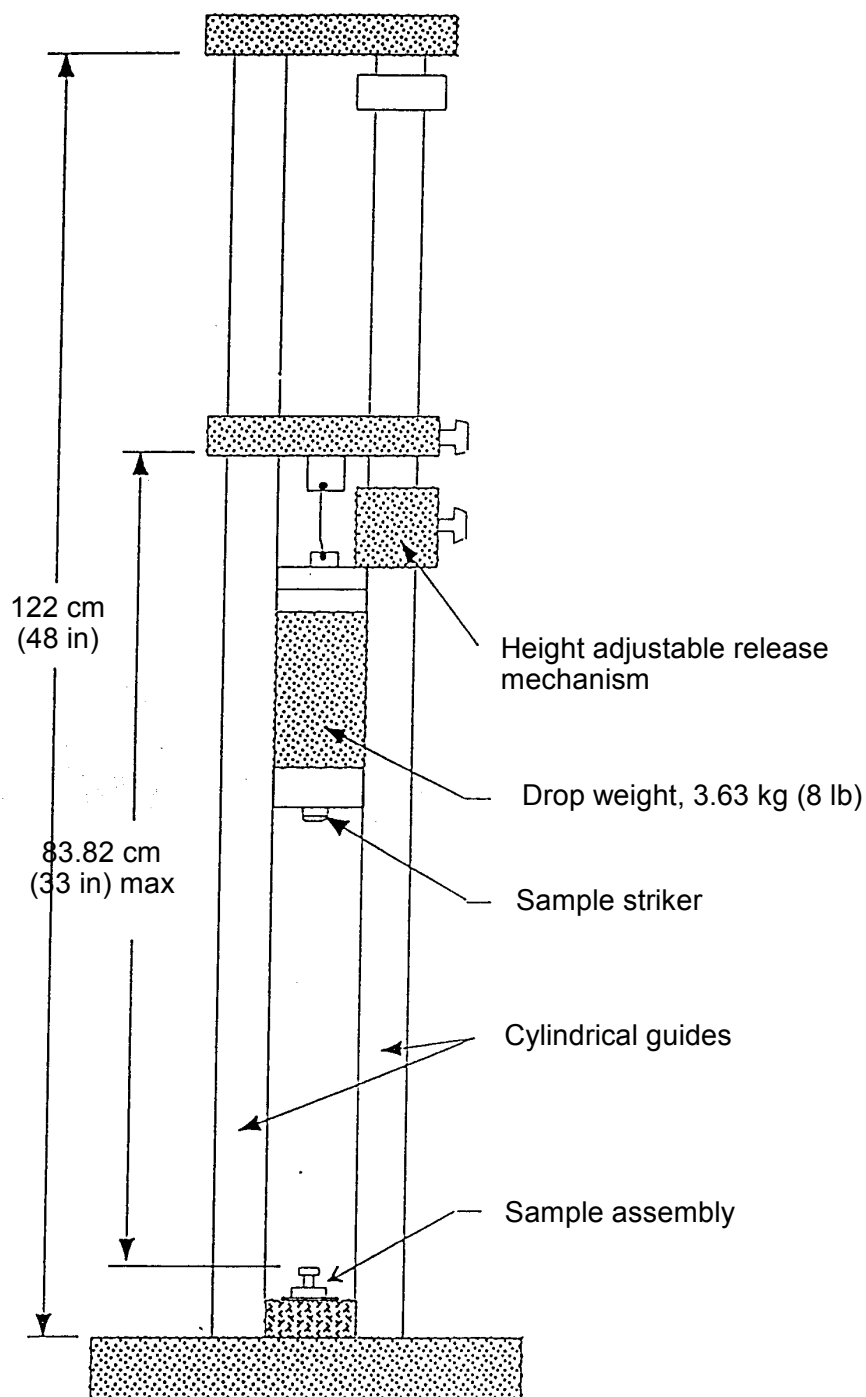

FIGURE 1. Impact test apparatus assembly (Bureau of Explosives design).

MIL-STD-1751A

Method 1012

Impact Sensitivity Test - ERL (Explosives Research Laboratory)/Bruceton Apparatus**1. TYPE OF TEST:** Impact

2. PURPOSE: This test is designed to measure the sensitivity of an energetic material to impact.

3. BACKGROUND: The apparatus is based on the design developed during World War II by the Explosive Research Laboratory of the National Defense Research Committee, located at Bruceton, PA. A more detailed description is provided in references (a) and (b).

4. TEST ARRANGEMENT: The test equipment consists of the following components:

4.1 Guide frame: A vertical framework of rods or rails designed to guide the drop weight during free-fall. This frame should provide a minimum of interference with the drop weight reducing external influences on the drop weight velocity.

4.2 Drop weight: The shape and construction of the drop weight may vary, but it must provide a 5.5-lb. (2.5-kg) mass capable of free-falling repeatedly from the maximum height of the guide frame. The impacting surface should be steel, hardened and suitably treated to avoid brittleness. Due to the changes in impulse duration, "dead-blow" or shot filled weights are not recommended.

4.3 Anvil: A solid metal base upon which the sample is placed during impact. The anvil should be solidly supported and contained to prevent it from moving during impact. The upper surface should be flat, hardened and perpendicular to the line followed by the drop weight. Multiple sections stacked together are permitted provided the joining faces are parallel, the contact is solid and lateral motion of all segments is restricted. A maximum of two segments is recommended. A diameter of 1.00 to 1.25 inches is recommended. The usual usage employs a disk of 180 grit sandpaper or garnet paper that nearly covers the face of the anvil as the surface upon which the sample is placed. This is referred to as "Type 12 Tools." When the sandpaper is omitted and the sample is placed directly on the anvil, the arrangement is referred to as "Type 12B Tools," and the striker and anvil are roughened by sandblasting them with No. 40 carborundum.

4.4 Striker: A solid tool steel mass designed to rest on the sample and transfer the impulse from the drop weight to the sample during impact. The striker should be supported to ensure that it does not move laterally during impact. The support should not restrict vertical motion. The striker and anvil should be aligned and centered under the drop weight. The upper face of the striker should be slightly convex. The lower face of the striker should be flat, hardened and parallel to the upper face of the anvil when in place. Multiple segments stacked together are permitted, provided joining faces are parallel, contact is solid and all segments are supported as described. If multiple segments are used, maximum of two segments is recommended. The diameter of the striker should match the diameter of the anvil.

4.5 Drop weight support: A mechanism shall be included to permit the drop weight to be suspended above the striker at a selectable height and released when desired. This support shall be capable of holding the drop weight at any point along the guide frame. The height of the drop weight when supported shall be measured from the lower face of the weight to the upper face of the striker when properly positioned on a sample. A scale may be attached or inscribed on the guide frame. Units of measure shall be in centimeters. The maximum height of the apparatus shall permit at least 100 cm of free fall. Although an electromagnet may be used to secure the drop weight, a mechanical catch is preferred due to the increased safety provided in a power loss situation.

MIL-STD-1751A

4.6 Optional components:

4.6.1 A remote and/or powered drop weight lift may be used provided it does not interfere with the weight when released.

4.6.2 Indents, stops or other preset height selectors may be incorporated into the design of the drop weight support. An electronic scale may be used for positioning.

4.6.3 Instrumentation to assist the operator in determining the presence of an energetic reaction may be employed. The use of such a device will be included with reported data. Any such method will include a method of verifying proper function. Complete documentation of the principle used and the basis for interpreting the output shall be kept for the life of the apparatus on which it is used.

4.6.4 Alternative configurations for the anvil and striker for the express purpose of evaluating liquids.

4.6.5 A device to measure velocity of drop weight at impact may be used to eliminate variability introduced by drag on the weight by the guides. It should be noted, however, that the calculations of the 50% height may be greatly complicated by this device and full documentation of the calculation method used must be maintained.

5. **PROCEDURE:**

5.1 A 35 ± 5 mg sample of material is placed on a square or disk of 180 grit sandpaper. The sandpaper should nearly cover the face of the anvil. Ground or granular materials should form a small pile. Solid materials may be cut into pieces for testing, with each piece weighing 35 ± 5 mg.

5.2 Drop weight heights intervals are based on the log of the height in centimeters, and are adjusted by 0.1 log intervals. A partial table of typical heights follows:

<u>Height (cm)</u>	<u>Log Interval</u>
10.0	1.0
12.6	1.1
15.8	1.2
20.0	1.3
25.1	1.4
31.6	1.5
39.8	1.6
50.1	1.7
63.1	1.8
100.0	2.0
—	—
—	—
—	—
316.2	2.5

5.3 The drop weight is adjusted to the desired height and secured. The sandpaper with the sample is placed on the anvil. The striker is inserted into its holder and gently lowered onto the sample. While observing the sample area, the drop weight is released. After recording the reaction, the drop weight is removed from the striker and the anvil and striker faces are cleaned.

MIL-STD-1751A

5.4 An examination of the sample remains and tooling is used to help determine whether or not an energetic response occurred.

5.5 The response is recorded as "FIRE" or "No-FIRE" and the height changed for the next shot. If a "FIRE" is detected, decrease the drop height one interval (0.1 log units). If a "No-FIRE" is detected, increase the height one interval. If the drop height is at the upper or lower limit and a change out of range is indicated, perform the next trial at the same height.

5.6 A minimum of 20 shots per sample is used to determine a 50% point.

6. RESULTS AND DATA:

6.1 The following information shall be reported for this test:

- a. Type of Apparatus
- b. Hammer Description
- c. Striker Description
- d. Dimensions
- e. Mass of impactor
- f. Type of tools used (12, 12b, or modified type 12)
 - i. Description of any grit that is used under the sample
- g. Sample Weight
- h. Method of Endpoint Detection, such as:
 - i. Sound – Microphone/recorder arrangement, ear
 - ii. Go/no Go determination methodology
 - iii. Smell
 - iv. Sight – flash, smoke, etc.
 - v. All or combination of above
- i. Method of Data Reduction, e.g., Bruceton Up/down
- j. Number of Drops per Test
- k. Number of Test Replications
- l. Experimental Material Result (H_{50}) with Standard Deviation
- m. Reference Material Result (H_{50}) with Standard Deviation

6.2 The Bruceton (or "stair-case") method of statistical analysis shall be used to determine a 50% point. Reference (c) provides a description of the statistical approach. Typical test data obtained on this apparatus at NSWC, White Oak is shown below:

<u>Explosive</u>	<u>50% Impact Height (cm)</u>
RDX, Type I or II, Class 1	21
RDX, Type I or II, Class 5	18
HMX, Grade B, Class 1	19
HMX, Grade B, Class 5	28
PETN, Class 4	13
TNT, Type I or II	78

7. SUPPLEMENTAL INFORMATION: The results shall be compared against Type I or II, Class 5 RDX, conforming to MIL-DTL-398, as the reference standard material. A second reference material is required.

MIL-STD-1751A

It should be chosen so that the 50% point for the candidate explosive falls between the values for the two references.

8. NATIONAL REFERENCES:

a. Walker, G. R., Whitbread, E. G., and Hornig, D. C., ed. *Manual of Sensitiveness Tests*, Balcartier, Quebec, Canada: Canadian Armament Research and Development Establishment. Published for Tripartite Technical Cooperation Program (TTCP), Panel O-2 (Explosives), Working Group on Sensitiveness, February 1966.

b. NATO STANAG 4489, *Explosives, Impact Sensitivity Test(s)*.

c. Dixon, W. J., and Massey, F. M. Jr., *Introduction to Statistical Analysis*. 4th ed. New York: McGraw-Hill Co., Inc., 1983.

MIL-STD-1751A

Method 1013**Impact Test (Laboratory Scale) - Los Alamos National Laboratory****1. TYPE OF TEST:** Impact

2. PURPOSE: This test determines the sensitivity to a normal impact of explosives in powder and liquid form. Results are reported at the 50% point using a Bruceton analysis and are compared to a Type I or II, Class 5 RDX standard conforming to MIL-R-398.

3. BACKGROUND:

3.1 The machine was originally similar to the ERL/Bruceton apparatus described in Test Method 1012. About 1957, some mechanical modifications were introduced for the purpose of improving test reproducibility. Reports indicated that the sensitivity scale was unchanged, however. Reference (a) provides a detailed description of the test.

3.2 The original drop weight was a hollow, conical, truncated nose-tipped cylinder fabricated of tool steel hardened to 60 HRC. The redesigned drop weight has the same general external appearance and the same weight of 5.5 pounds (2.5 kg). It consists of a steel core hardened to 55-58 HRC surrounded by a solid case of Dural (aluminum alloy). The redesign concentrates more of the mass centrally, along the line of impact.

4. TEST ARRANGEMENT:

4.1 The Los Alamos striker is a hardened steel rod, 1.25 inches in diameter and 5.125 inches in length. Like other strikers used in the ERL design, the upper round end of 2.50 inches radius is struck by the drop weight. The lower end is close to the ground such that it is flat and parallel to the upper surface of the anvil. Typically, a piece of sandpaper or garnet paper is placed beneath the sample. This combination of tooling and sandpaper is referred to as "Type 12 tools".

4.2 Los Alamos uses both Type 12 tools and also a tooling variation which is designated as "Type 12B." Type 12B is different from Type 12 in the following:

- a. No sandpaper is used to hold the explosive sample.
- b. The striker and anvil surfaces are prepared by sandblasting them with No. 40 Carborundum grit, or an equivalent abrasive.

4.3 Sample response is measured with an electronic noise meter with which a threshold is established to differentiate between explosions (go's) and non-explosions (no-go's). By a series of trials, the drop weight which causes 50% of the test samples to explode is determined. An Altec Model 21BR-180 microphone, Model 165A base and Model 527A power supply (or equivalent microphone), and power supply is connected to the noise meter so that these conditions can be recorded. The microphone is very stable over long periods of time and is not overloaded by the loudest explosions encountered in the test.

4.4 Each test sample consists of about 40 mg explosive. When sandpaper is used (Type 12 tools), a shallow depression is made in the center of the sandpaper so that spherical-grained materials do not roll off while the samples are prepared.

5. PROCEDURE:

5.1 In the standard impact test, 40 mg samples of loose powder are placed in the center of 1-inch squares

MIL-STD-1751A

of garnet paper which is centered on the anvil. To save time, individual samples are not weighed. Instead, the test explosive is volumetrically loaded with a small scoop. Equivalent scoop loads are then used for subsequent shots. By careful application of this method, 40 ± 2 mg samples can be quickly dispensed. When sufficient material is available, it is blended and sieved. Test samples are then taken from that portion of the bulk sample which passes through a No. 100 sieve but is retained on a No. 200 sieve. However, when only limited quantities are available, explosives are tested "as received." Solid samples can either be tested as a solid wafer or ground into a powder. When reporting results, the final form of the test sample shall be reported.

5.2 The impact sensitivity of a test explosive is reported as H_{50} , the drop weight in centimeters, which causes a sample to explode 50% of the time. This is determined from a test series with drop heights chosen by the Bruceton stair-step plan. A minimum of 25 shots are conducted to establish the H_{50} level. The striker and anvil are cleaned with an appropriate solvent and inspected for damage after each shot. Drop height steps are selected to have equal 0.1 intervals on a logarithmic scale, with a 10-cm drop height taken as 1.0. Development of the data reduction method is described in reference (b).

6. RESULTS AND DATA:

- 6.1 The following information shall be reported for this test:
- a. Type of Apparatus (e.g., BOE, NOL, ERL, etc)
 - b. Hammer Description
 - c. Striker Description
 - d. Dimensions
 - e. Mass of impactor
 - f. Type of tools used (12 or 12b)
 - i. Description of any grit that is used under the sample
 - ii. Finish on anvils, if no sandpaper/grit is used
 - g. Sample Weight
 - h. Method of Endpoint Detection, such as
 - i. Sound – Microphone/recorder arrangement,
 - ii. Go/no Go determination methodology
 - iii. Smell
 - iv. Sight – flash, smoke, etc.
 - v. All or combination of the above
 - i. Method of Data Reduction, E.g., Bruceton
 - j. Number of Drops per Test
 - k. Number of Test Replications
 - l. Experimental Material Result (H_{50}) with Standard Deviation
 - m. Reference Material Result (H_{50}) with Standard Deviation

6.2 The drop weight which causes an explosive sample to explode 50% of the time is measured in centimeters. M , the logarithm of the 50% height (H_{50}), is calculated as followed. The lowest drop height step at which shots were fired during the stair-step sequence is assigned an i value of 0. Successive higher steps are assigned values of 1, 2, 3, etc. Then:

$$N = \sum n_i = \text{total no-go's during series, including step 0}$$

$$A = \sum i = n_i$$

$$B = \sum i^2 n_i$$

where n_i is the number of no-go's at step i . Then:

MIL-STD-1751A

$$M = C + D (A/N \pm 0.5) \text{ and}$$

$$S = 1.620 D \left(\frac{NB - A^2}{N^2} \right)$$

where C is the logarithm of step height 0, D is the step interval in logarithm units, and S is the standard deviation of M. The value of H_{50} is obtained by taking the antilog of M. Table I tabulates H_{50} values for eight common explosives. Long-time control charts are maintained on explosives used as standards in group tests and on other frequently tested materials.

7. **SUPPLEMENTARY INFORMATION:** Type I or Type II, Class 5 RDX, conforming to MIL-DTL-398, shall be used as a standard reference material against which the results will be compared.

8. NATIONAL REFERENCES:

a. Walker, G. R., Whitbread, E. G., and Hornig, D. C., ed. *Manual of Sensitiveness Tests*. Valcartier, Quebec, Canada: Canadian Armament Research and Development Establishment. Published for Tripartite Technical Cooperation Program (TTCP), Panel 0-2 (Explosives), Working Group on Sensitiveness, February 1966, pp. 24-26.

b. *Statistical Analysis for a New Procedure in Sensitivity Experiments*, AMP Report No. 101.1R, SRG-p, No. 40, July 1944, Statistical Research Group, Princeton University. Submitted to Applied Mathematics Panel, National Defense Research Committee.

TABLE I. Results of analysis of impact data (Type 12 tools).

	No. of 25-shot tests	H_{50} (cm)	σ (cm)
PETN	14	12.0	1.1
RDX	96	22.2	1.0
HMX	62	26.0	1.8
Cyclotol	15	36.6	2.0
Octol (75/25)	12	38.1	2.2
Tetryl	6	41.6	1.3
Comp B	25	59.1	3.6
TNT	23	154.0	7.6

MIL-STD-1751A

Method 1014

Impact Test (Drop Hammer) - Bureau of Mines**1. TYPE OF TEST:** Impact

2. PURPOSE: This test is designed to measure the sensitivity to initiation of an explosive in powder form to the types of mechanical stimuli encountered during manufacture or rough handling.

3. BACKGROUND: None

4. TEST ARRANGEMENT:

4.1 The Bureau of Mines impact apparatus subjects an explosive sample to an impact of a free-falling 5-kg drop hammer. This hammer is guided within a steel T-beam framework which rises 150 inches vertically from a steel base resting on a concrete pier. The hammer is held, prior to dropping, by an electromagnet within a movable yoke. This yoke can be moved up or down, on the hammer's guide rails, by a windlass at the base of the machine. A recording device on the windlass measures the drop height which is 130 inches maximum. The hammer is released by a manual push-button which cuts the current to the electromagnet.

4.2 The anvil assembly, mounted on the base of the machine, consists of a hardened steel anvil and a plunger, 1.25 inches in diameter and 6 inches in length, machined to give a sliding fit through a steel guide ring. The drop hammer, when released, strikes the plunger which transmits the force developed on impact to a small striking pin that fits into a steel cup containing the test sample.

4.3 For tests in which the sample explosive is confined, the striking pin, 0.5 inch in diameter by 0.94 inch in length, Type 440 stainless steel, hardened to 55-60 HRC, is ground and polished to give a snug, freely sliding fit in the sample cup. The striking face of the pin is chamfered to clear the radius at the bottom of the sample cup. The sample cup, which is approximately 0.5 inch in diameter by 0.28 inch deep, Type 302 stainless steel with a wall thickness of 0.005 inch. Reference (a) provides a more detailed description of the test apparatus.

4.4 Figures 1 through 4 provide diagrams of the test setup.

5. PROCEDURE:

5.1 The test sample of approximately 35 mg is placed in the stainless steel sample cup, and the striking pin is gently pressed down on the sample. This assembly is then centered on the anvil by a shallow socket at the lower end of the plunger. The hammer is dropped from a given height onto the plunger. If no explosion or reaction occurs, the test is repeated with a fresh charge from successively greater heights until a reaction occurs or until the maximum range of the equipment is reached. If a reaction does occur, fresh samples are tested at successively lower heights of fall until a point of no reaction is reached. Thereafter, a sample will be tested at a given increment below the level at which the previous sample was tested if that sample reacted, and a given increment above the level at which the previous one was tested if it did not react.

5.2 By using this up-and-down method and analyzing the data statistically, a height for 50% ignition probability is attained. The procedure for determining this height for 50% probability of ignition, and the

MIL-STD-1751A

error therein at a 95% confidence level, is discussed by Dixon and Mood, reference (b), and Dixon and Massey, reference (c).

5.3 The determination of an "explosion or reaction" is based on visual observation. Any indication of decomposition (explosion, burning, flash, smoke or charring) is considered a "go".

6. RESULTS AND DATA:

6.1 The following information shall be reported for this test:

- a. Type of Apparatus
- b. Hammer Description
- c. Striker Description
- d. Dimensions
- e. Mass of impactor
- f. Type of tools used (12 or 12b)
 - i. Description of any grit that is used under the sample
 - ii. Finish on anvils, if no sandpaper/grit is used
- g. Sample Weight
- h. Method of Endpoint Detection, such as
 - i. Sound – Microphone/recorder arrangement,
 - ii. Go/no Go determination methodology
 - iii. Smell
 - iv. Sight – flash, smoke, etc.
 - v. All or combination of the above
- i. Method of Data Reduction, E.g., Bruceton
- j. Number of Drops per Test
- k. Number of Test Replications
- l. Experimental Material Result (H_{50}) with Standard Deviation
- m. Reference Material Result (H_{50}) with Standard Deviation

6.2 Typical results for standard explosives are provided below:

Explosive	50% Probability Height	
	(inch)	(cm)
PETN, Class 7	16.93	43
RDX, Class 5	31.10	79
Tetryl	37.00	94
TNT, Type I or II	72.05	183

7. SUPPLEMENTARY INFORMATION:

7.1 The principal difference between this test and the NOL impact - ERL/Bruceton test is the use of sandpaper in the NOL test and the size of the drop weight.

MIL-STD-1751A

7.2 The results shall be compared against Type I or II, Class 5 RDX, conforming to MIL-DTL-398, as the reference standard material. A second reference material is required. It should be chosen so that the 50% point for the candidate explosive falls between the values for the two references.

8. NATIONAL REFERENCES:

a. Becker, K.R., *Bureau of Mines Instrumented Impact Tester*. U.S. Department of Interior, Bureau of Mines, Report of Investigations 7670, 1972.

b. Dixon, W.J., and Mood, A.M., "Method for Obtaining and Analyzing Sensitivity Data." *Journal of the American Statistics Association*. 43: 109-126, 1948.

c. Dixon, W.J., and Massey, A.M. Jr. *Introduction to Statistical Analysis*. 4th ed., New York: McGraw-Hill Co., Inc., 1983, pp. 318-327.

MIL-STD-1751A

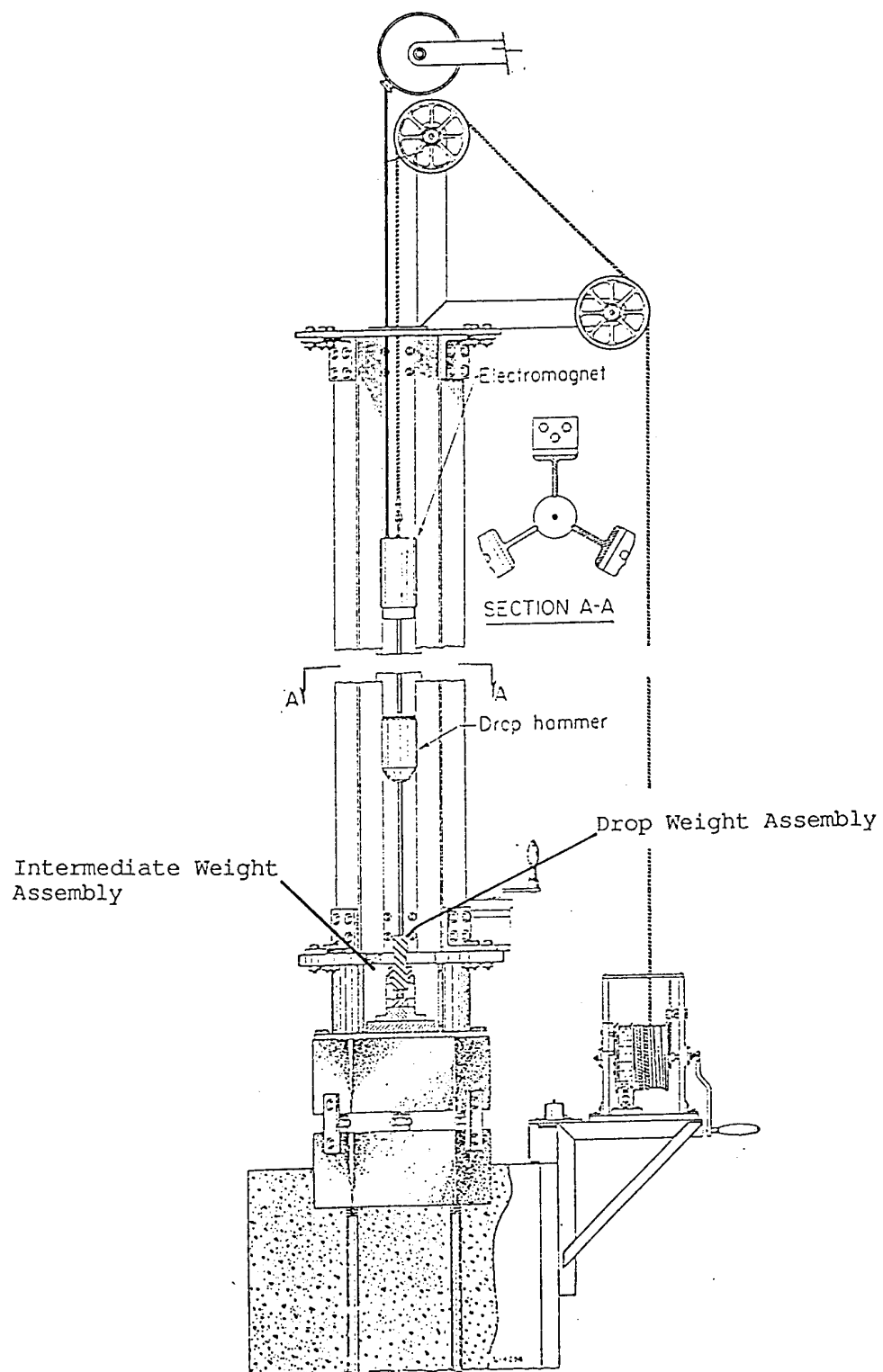
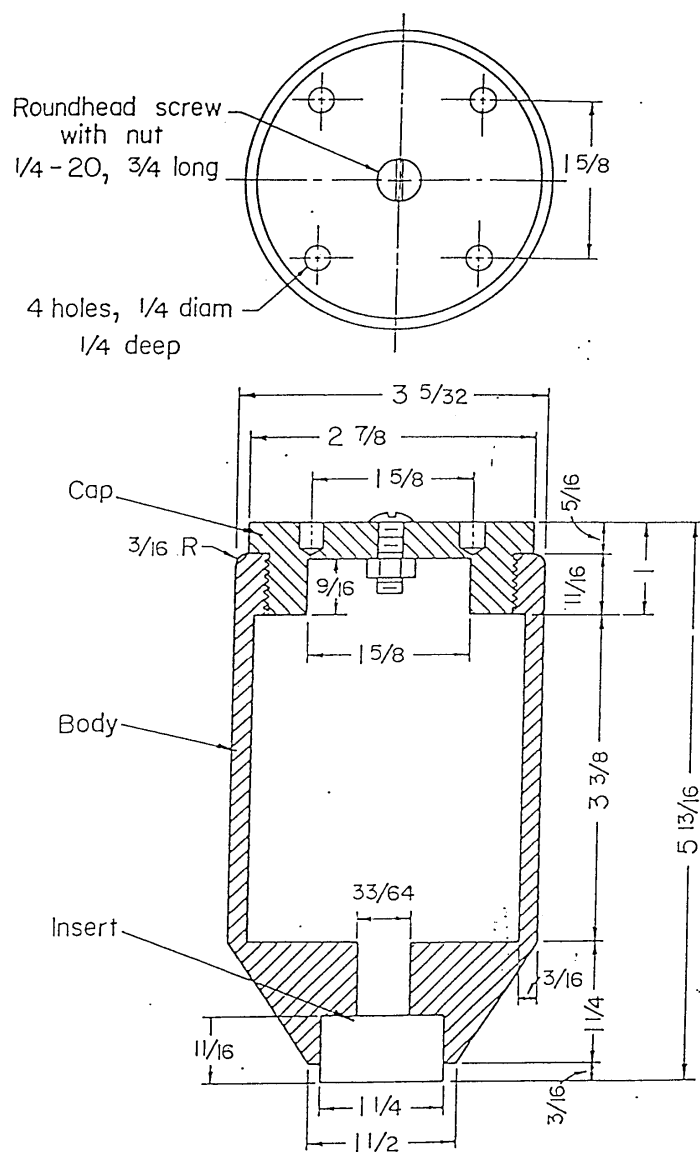

FIGURE 1. Impact test apparatus assembly (Bureau of Mines design).

MIL-STD-1751A

FIGURE 2. Drop weight assembly (Bureau of Mines design).

MIL-STD-1751A

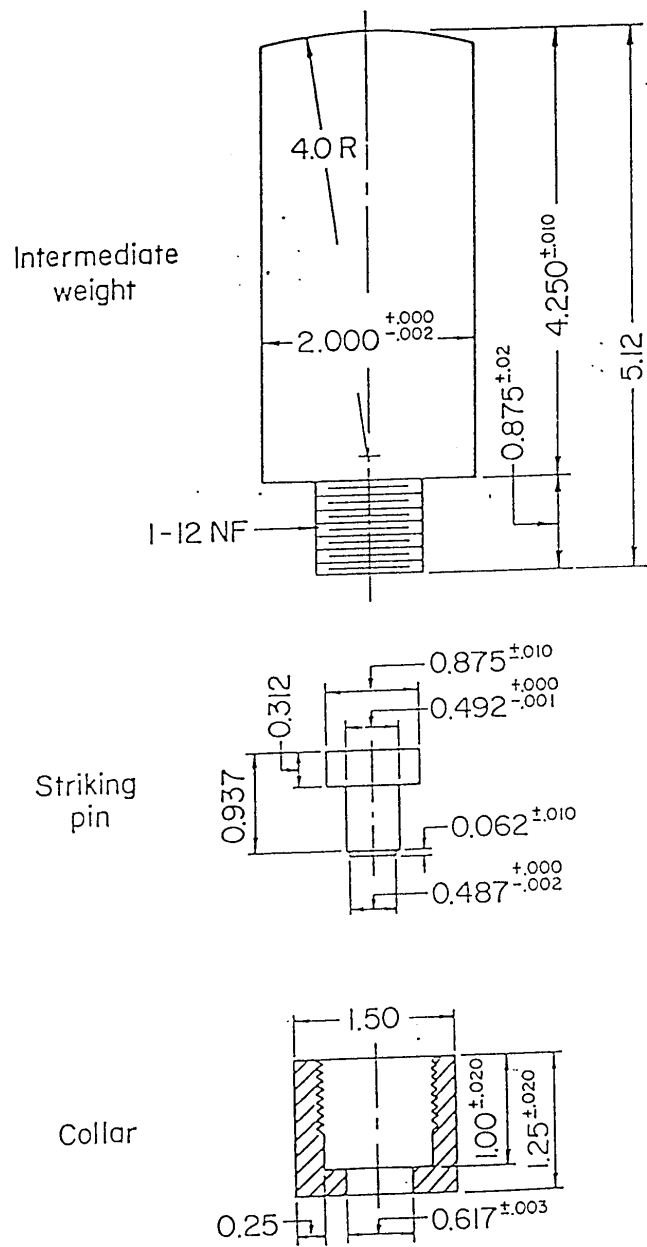
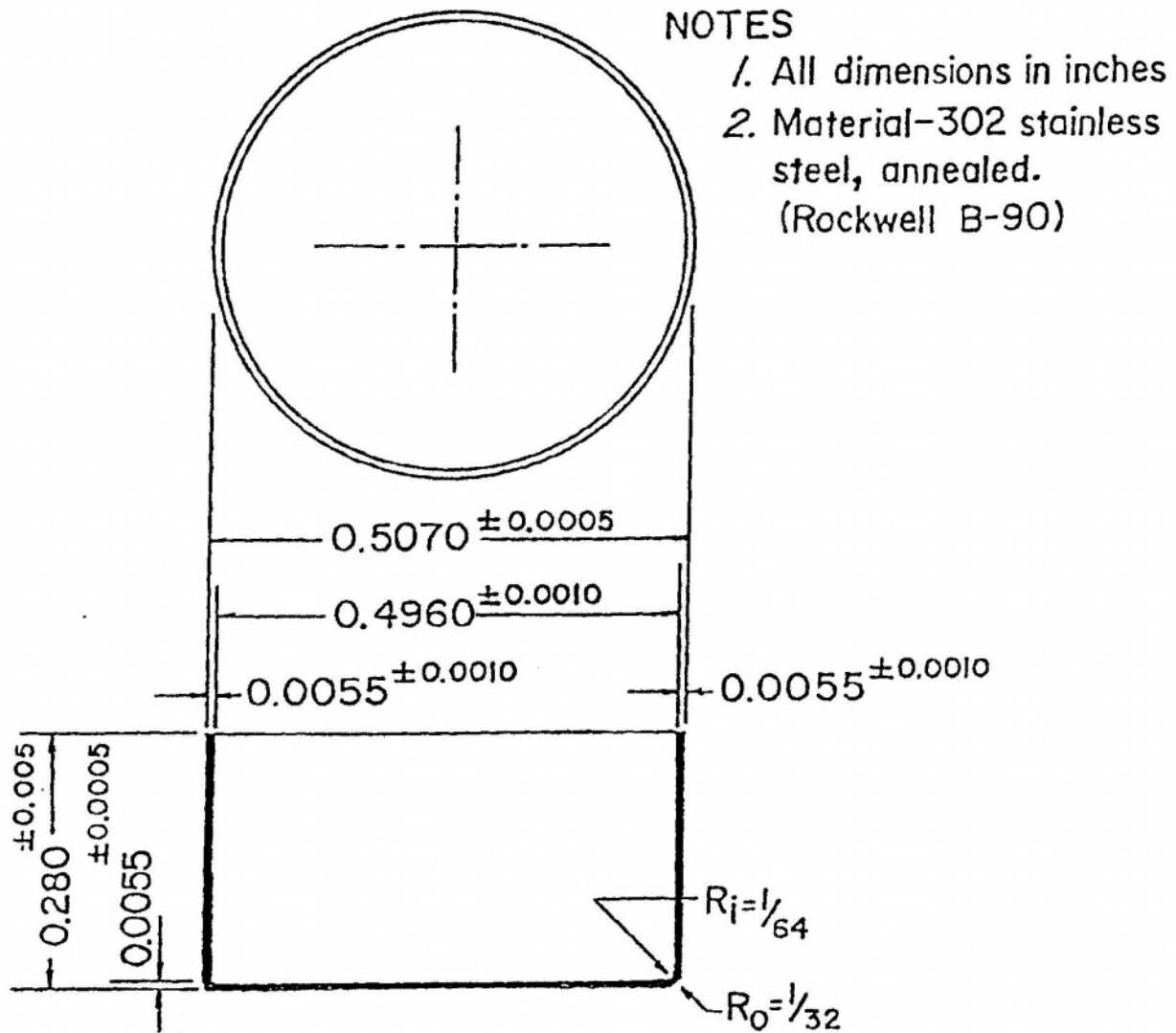

FIGURE 3. Intermediate weight assembly (Bureau of Mines design).

MIL-STD-1751A

FIGURE 4. Sample confinement cup assembly (Bureau of Mines design).

MIL-STD-1751A

Method 1015

BAM Impact Test Apparatus

1. TYPE OF TEST: Impact

2. PURPOSE: The BAM drop weight test was developed for the evaluation of solid or liquid substances to a normal impact.

3. BACKGROUND: The test has been agreed upon to be used as a standardized NATO qualification test procedure complying with reference (a).

4. TEST ARRANGEMENT:

4.1 The device consists of a cast steel block whose base is bolted to a concrete block. Imbedded in the steel block is the main anvil on which an intermediate anvil holding the impact device rests. Guide rails, which are attached to the steel block, facilitate free vertical movement of the drop weight and release mechanism. A toothed rack is incorporated into one of the guide rails to arrest the rebounding drop weight. The drop weight is positioned at various heights by means of a motor driven winch.

4.2 The impact device consists of two coaxially arranged steel cylinders held in place by a cylindrical steel guide ring. The cylinders are roller bearings approximately 10 mm in diameter x 10 mm in height with polished surfaces and rounded edges. Hardness is 58 to 65 HRC. The impact device rests on the intermediate anvil, a steel cylinder approximately 26 mm in diameter x 26 mm in height. It is centered there by means of a steel ring containing six concentrically arranged holes that permit the escape of reaction gases.

4.3 Drop weights of 1, 2, 5, and 10 kg are available for testing. The body of each drop weight has two guide grooves in which it moves between the guide rails. It is equipped with suspension spigot that arrests the weight in the release mechanism, a rebound catch, a height marker, and the cylindrical striker. The striker is made of steel with a hardness of 60 to 63 HRC. Figures 1 through 4 of reference (a) provide schematics of the test set-up and associated hardware drawings.

5. PROCEDURE:

5.1 Solid explosive substances are tested in the dry state. Powdered materials are sieved and the fraction with a particle size ranging from 0.5 to 1.0 mm is used for testing. Pressed, cast, and otherwise compacted substances are crushed and then sieved. Liquid explosive substances are tested without preparation.

5.2 The impact device is prepared by pushing one of the cylinders partially into a guide ring. This open impact device is then positioned on the intermediate anvil fitted with the locating ring. Using a measuring spoon, approximately 35 mg of the substance is placed inside the open impact device making sure that a center heap is formed. The impact device is then closed with a second cylinder by pressing it into a guide ring until it touches the sample. When testing liquids, a pipette is used to transfer 40 mm³ on the lower cylinder. In this case, care must be taken to allow a 10-mm gap between the two cylinders when the impact device is closed.

5.3 The initial starting impact height is selected based on previous experience. A limited number of tests are performed to ensure that results group together fairly well. A 25-shot test is then performed using a Bruceton analysis to determine a 50% point. In judging test results, reactions are classified as either

MIL-STD-1751A

"no reaction," decomposition, or explosion. Decomposition can be recognized by flame, smoke, or by the deposition of soot on the impact device. Both decompositions and explosions are considered positive reactions for the purposes of conducting the statistical analysis.

6. RESULTS AND DATA:

6.1 The following information shall be reported for this test:

- a. Type of Apparatus
- b. Mass of impactor
- c. Sample Weight
- d. Method of Endpoint Detection, such as
 - i. Sound – Microphone/recorder arrangement,
 - ii. Go/no Go determination methodology
 - iii. Smell
 - iv. Sight – flash, smoke, etc.
 - v. All or combination of the above
- e. Method of Data Reduction, E.g., Bruceton
- f. Number of Drops per Test
- g. Number of Test Replications
- h. Experimental Material Result (H_{50}) with Standard Deviation
- i. Reference Material Result (H_{50}) with Standard Deviation

6.2 Typical results for standard explosives are provided below:

Explosive	50% Probability Height	
	(inch)	(cm)
PETN	14	36
RDX, Class 5	23	58
TNT	68	173

7. SUPPLEMENTARY INFORMATION: The results shall be compared against Type I or II, Class 5 RDX, conforming to MIL-DTL-398, as the reference standard material. A second reference material is required. It should be chosen so that the 50% point for the candidate explosive falls between the values for the two references.

8. REFERENCES:

- a. NATO STANAG 4489, *Explosives, Impact Sensitivity Test(s)*.

MIL-STD-1751A

Method 1016

Ball Drop Impact Test

1. TYPE OF TEST: Impact

2. PURPOSE: This test determines the sensitivity to impact of primary explosives.

3. BACKGROUND: This method is the test that is appropriate for determining the impact sensitivity of primary explosives. It was developed at U. S. Army TACOM ARDEC (Picatinny Arsenal).

4. TEST ARRANGEMENT: The Ball Drop Impact Test apparatus, shown in Figure 1, subjects a primary explosive to an impact of a free-falling steel ball.

4.1 Sample size: The standard sample size is 30 mg for each trial.

4.2 Weight: The drop weight is a 0.500-inch diameter steel ball weighing 8.35 grams

4.3 Drop-weight Assembly: The steel ball is guided on a ball track which rises 32-inches vertically from a steel base. The ball track may be moved up or down and locked in place.

5. PROCEDURE:

5.1 The test sample of approximately 30 mg is placed on the impact block. The sample is spread into a thin layer by moving a straight-edged conductive spatula along the top of the shoulders of the impact block. The steel ball guide is raised to the desired height and locked in place. The loaded impact block is positioned beneath the ball track. A ball track metal shield is used to keep the steel ball in place. The ball track shield is in the lowered position and the steel ball is placed in the track. The ball shield is raised using a cord and the steel ball is allowed to fall onto the sample. If no explosion or reaction occurs, the test is repeated with a fresh sample from successively greater heights until a reaction occurs or until the maximum range of the equipment is reached. If a reaction does occur, fresh samples are tested at successively lower heights until a point of no reaction is reached. Thereafter, a sample will be tested at 1 inch below the level at which the previous sample was tested if that sample reacted, and 1 inch above the level at which the previous one was tested if it did not react.

5.2 A Bruceton up-down method is employed to determine the height, H_{50} , at which the probability of reaction is 50%

5.3 The determination of an explosion or reaction is based on visual observation. Any indication of decomposition (explosion, burning, flash, smoke or charring) is considered a positive reaction.

6. RESULTS AND DATA:

6.1 The following information shall be reported for this test:

- a. Sample weight
- b. Method of endpoint detection, such as:

MIL-STD-1751A

- i. Sound – Microphone/recorder Arrangement, Ear
- ii. Go/no Go determination methodology
- iii. Smell
- iv. Sight – Flash, Smoke, Etc.
- v. All or combination of above
- c. Number of drops per test
- d. Number of test replications
- e. Method of data analysis
- f. Experimental material result with standard deviation
- g. Reference material result with standard deviation

6.2 Typical test data obtained on this apparatus are shown below:

Explosive	H ₅₀ (in)
Lead azide, dextrinated	25.6 ± 2.8
Lead styphnate	13.9 ± 2.9
NOL-130	11.1 ± 3.9

* H₅₀ is the value (from the Bruceton Up and Down Method) at which 50% of the samples react.

7. **SUPPLEMENTARY INFORMATION:** None.

8. **NATIONAL REFERENCES:** None.



FIGURE 1. Ball Drop Impact Apparatus

MIL-STD-1751A

Method 1017**Impact Test - JANNAF Method****1. TYPE OF TEST:** Impact

2. PURPOSE: This test determines the sensitivity to a normal impact of explosives in liquid or solid form.

3. BACKGROUND: This method is the test that has been adopted by the American Society for Testing and Materials (ASTM) as a standard test method for determining the impact sensitivity of liquid monopropellants. It has also been adapted for use in determination of the impact sensitivity of solids. Reference (a) is the ASTM standard method. It is identical in substance to the JANNAF method g, "Drop Weight Test," Test Number 4, given in reference (b).

4. TEST ARRANGEMENT:**4.1 Liquid materials:**

a. **Sample Cup Assembly:** The sample cup assembly is shown in Figure 1. It comprises a body, which surrounds the sample cup; a sample cup; an expendable o-ring; an expendable diaphragm, which covers the sample; a piston, which rests on the diaphragm; a ball, which is struck by the drop weight; and a cap to secure the parts of the assembly.

b. **Sample size:** The standard sample size is 0.03 mL. Tests in which the sample volume is varied (at constant cavity volume of 0.06 mL) show that the degree of filling affects the result.

c. **Weight:** The drop weight is an integral assembly weighting $2 \text{ kg} \pm 1 \text{ g}$. It is held suspended by an electromagnet.

d. **Drop-weight Assembly:** The drop-weight assembly consists of a base plate with four leveling screws; a column; two guide rods (one graduated); a body retainer; a release mechanism, adjustable to retain the magnet; and a top plate. The maximum height for a drop is 50 cm.

4.2 Solid materials:

a. **Sample holder:** An adapter, shown in Figure 2, is available for handling solid materials in this test. It is based on an adaptation of a design by the Bureau of Mines. The assembly consists of a stainless steel body, a hardened steel anvil and plunger, a plunger guide and retaining ring, and a brass sample cup. The plunger tip diameter is 0.304 inches.

b. **Sample size:** The standard sample size for solids is 0.020 g.

c. **Weight:** The weight used for solids is a 1 kg weight. If no reaction is observed at the 50 cm height with a 1 kg weight, other weights are used to determine E_{50} .

d. **Drop-weight assembly:** The drop-weight assembly is the same as that used for liquids.

MIL-STD-1751A

5. PROCEDURE:**5.1 For liquid materials:**

- a. The drop-weight is set at the desired height and secured in place with the safety latch.
- b. Sample preparation: The O-ring is inserted into the bottom of the cavity in the sample cup, and a 0.03 mL sample of the material to be tested is injected into the bottom of the cavity. A diaphragm is slid across the top surface of the cup so that it drops flat onto the O-ring. The piston is placed in the cup and the cup is inserted into the body. The ball is placed on top of the piston and secured in place by the cap, which is screwed onto the body and tightened with a torque wrench to 7 lb-in.
- c. The body assembly is placed into the retainer on the stand. The weight is released by de-energizing the electromagnet.
- d. The test result is recorded as positive or negative, the body disassembled and cleaned, the height selected for the next drop, and steps 5.1.a through 5.1.c are repeated for a minimum of 20 trials, using a Bruceton up-down method.
- e. If ten (10) successive trials at the maximum height are negative, the test is discontinued and the result reported as negative.
- f. If a trial at 2 cm is positive, the trial is repeated six (6) times. If any negative results occur, up-down method should be employed to determine the 50% point. If six positive results occur within ten (10) trials at the minimum height (2 cm), the testing is discontinued and the 50% point reported as less than 1 cm.

5.2 For solid materials:

- a. The drop-weight is set at the desired height and secured in place with the safety latch. For the first trial, the 1-kg weight is set at the maximum height of the apparatus (50 cm).
- b. Sample preparation: For granulated materials, the sample used is that portion which will pass through a No. 50 and be retained by a No. 100 U. S. Standard Sieve. For non-granular material, a disc may be cut from a sheet of proper thickness by pressing a brass sample cup onto a sheet of the material resting on a brass plate. Prepared sample should be kept desiccated until tested. A brass cup containing the sample is placed on the anvil, and the plunger tip is carefully inserted into the cup.
- c. The Sample holder is placed on the Drop-Weight Tester and the weight is gently lowered onto the plunger to compact the sample and ensure contact between the parts of the apparatus. The weight is released by de-energizing the electromagnet. The test result is recorded as positive or negative.
- d. If the first result (1 kg at 50 cm) is negative, the drop weight is increased to 6 kg, and steps 5.2.a through 5.2.c are repeated.
 - i. If the results are negative for ten (10) trials, testing is stopped and the result reported as negative at 300 kg-cm.
 - ii. If the result at 300 kg-cm is positive, the weight is decreased and increased successively by halves in a Bruceton up-down approach until a 50% point is bracketed. The minimum increment should be equal to approximately 5% of the total value.
- e. If the first result 50 kg-cm is positive, the height is selected for the next drop, and steps 5.1.a through 5.1.c are repeated for a minimum of 20 trials, using a Bruceton up-down method.

6. RESULTS AND DATA:**6.1 The following information shall be reported for this test:**

- a. Sample weight
- b. Method of endpoint detection, such as:
 - i. Sound – Microphone/recorder Arrangement, Ear
 - ii. Go/no Go determination methodology
 - iii. Smell

MIL-STD-1751A

- iv. Sight – Flash, Smoke, Etc.
- v. All or combination of above
- c. Number of drops per test
- d. Number of test replications
- e. Method of data analysis
- f. Experimental material result with standard deviation
- g. Reference material result with standard deviation

6.2 Typical test data obtained on this apparatus is shown below:

* H_{50} is the value (from the Bruceton Up and Down Method) at which 50% of the samples react.

7. SUPPLEMENTARY INFORMATION:

7.1 Results of this test have been found to be temperature-dependent. It is therefore very important to provide means to thermostat the sample, cups, pistons, body of the assembly, and the liquid to be tested unless the whole apparatus is kept in a constant-temperature room.

7.2 A more detailed description of the test apparatus for solids testing may be obtained from reference (c)

8. NATIONAL REFERENCES:

a. *ASTM Method D 2540-70, Standard Method for Drop-Weight Sensitivity of Liquid Monopropellants*, American Society for Testing and Materials, Philadelphia, PA.

b. "Liquid Propellant Test Methods, Recommended by the Joint Army-Navy-Air Force Panel on Liquid Propellant Test Methods," Chemical Propulsion Information Agency, Applied Physics Laboratory, the Johns Hopkins University, Silver Spring, MD.

c. *Data Bulletin # 61770: Technoproducts Drop-Weight Tester Procedure for Testing Solids*, Technoproducts, Inc., Saratoga California.

MIL-STD-1751A

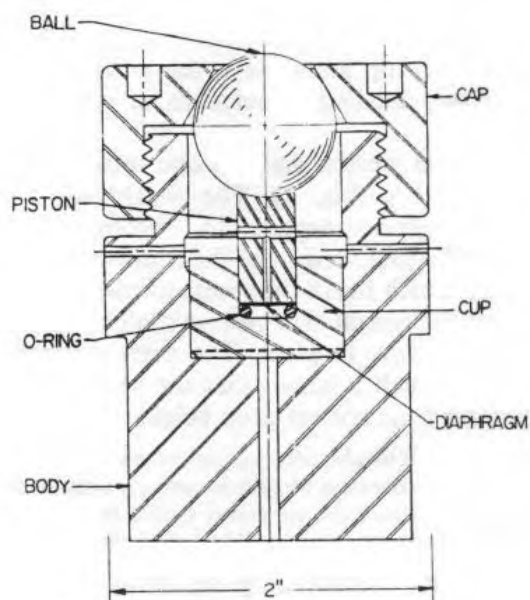

FIGURE 1. Sample cup assembly for liquids

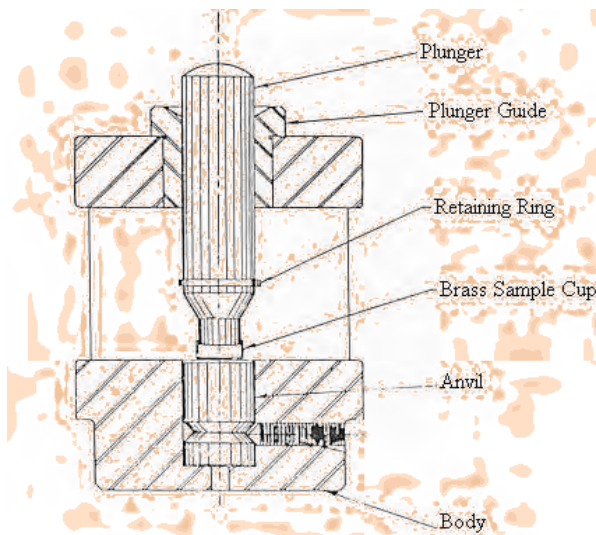

FIGURE 2. Sample cup assembly for solids

MIL-STD-1751A

Group 1020
Test Methods
Friction Sensitivity

MIL-STD-1751A

Method 1021**Friction Sensitivity- ABL Sliding Friction Test****1. TYPE OF TEST:** Friction Sensitivity

2. PURPOSE: This test is used to determine the sensitivity of a substance when subjected to a sliding frictional force.

3. BACKGROUND: None.

4. TEST ARRANGEMENT

4.1 Figure 1 provides a schematic of the test apparatus. The wheel, whose position is fixed, and anvil are constructed of steel (Rockwell hardness "C" 58 ± 4) with a finish of $1.6 \mu\text{m}$ ($63 \mu\text{inches}$) with finish lines normal to the direction of motion. To conduct the test, force is applied hydraulically through the non-rotating wheel to the sample which rests on the anvil. A pendulum impacting on the edge of the anvil propels the anvil at a known velocity, perpendicular to the compressive force that is applied to the sample. Normally, the anvil slides one inch. The compressive force is measured by a gauge and the initial velocity determined by calibration.

4.2 Test conditions will vary depending on the requirements. However, a temperature range of $25 \pm 5^\circ\text{C}$ is normally used. Relative humidity should range between 15 to 85% but should not exceed a level that could cause deliquescence of the test sample

4.3 Samples may either be tested as solid wafer, a bulk powder, or liquid. Sample weight is approximately 50 mg. Powders are sieved to pass through a #60 screen ($\approx 0.25 \text{ mm}$) while solid samples are cut into 0.25 inch width x 1.0 inch length specimens which are placed along the sliding contact surface. A uniform sample thickness of approximately 0.03 inches is generally employed. The top and bottom surfaces of each sample should not contain any portion of the original cast-cure surface.

5. PROCEDURE:

5.1 As shown in figure 1, the wheel is lowered onto the substance and force is applied to the wheel. An initial force of 1000 lb is typically used although a range of 10 to 1800 lb is available. A pendulum is used to strike the anvil which is normally propelled at a velocity of 8 ft/sec. The anvil and sample are then slid across the wheel at which the test result is noted. The velocity of the anvil may be changed by altering the angle from which the pendulum is released.

5.2 A trial is considered positive if any of the following results are obtained; visible sparks, visible flame, audible explosion, loud crackling, or the detection of reaction products by a gas analyzer.

5.3 A twenty-shot sample is used to determine a 50% point by the Bruceton method using a 0.1 log-pound ram force as the test variable. This is then compared to results obtained using a Type I or II, Class 5 RDX standard conforming to MIL-DTL-398.

MIL-STD-1751A

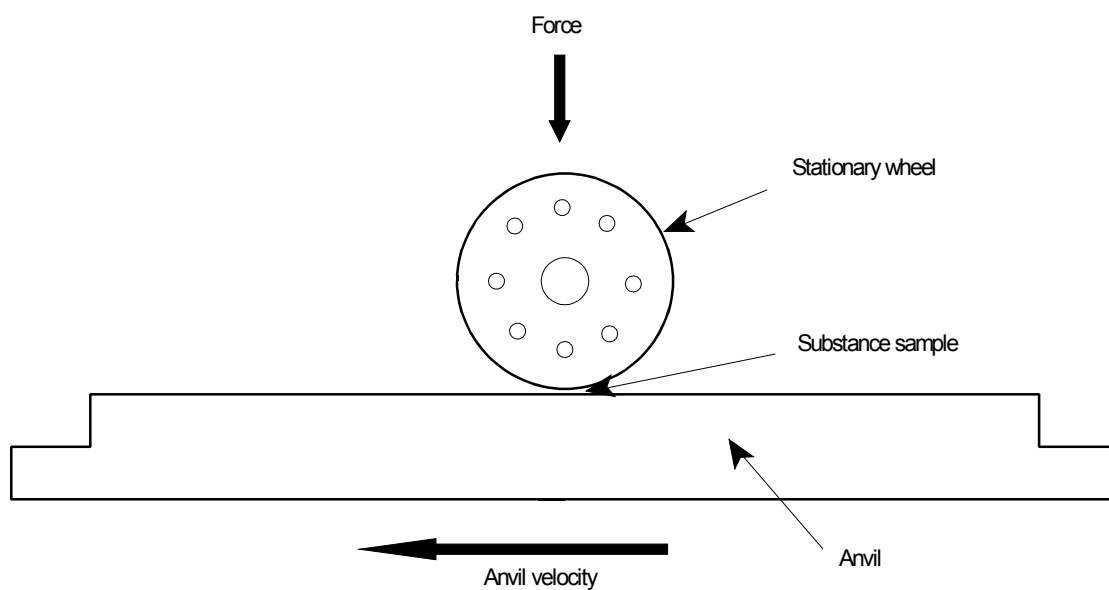

FIGURE 1. ABL sliding friction test assembly.

MIL-STD-1751A

6. RESULTS AND DATA:

6.1 The following information shall be reported for this test:

- a. Finish on the anvil
- b. Metric being reported (50% initiation level or threshold initiation level (TIL))
- c. Criterion for determining go vs. no-go
- d. Velocity of the anvil
- e. Number of trials per test result
- f. Number of replications of the test
- g. Sensitivity, in terms of force applied to the wheel, of the candidate material
- h. Sensitivity, in terms of force applied to the wheel, of reference standards.

6.2 A propellant or explosive with a 50% initiation level less than 250 pounds should be regarded as unusually sensitive to initiation by friction. A propellant or explosive which fires at 50 pounds should not be handled unless special safety precautions are taken.

7. SUPPLEMENTARY INFORMATION:

7.1 This test has also been adopted by the United Nations as a standardized procedure used for the hazard classification of explosive substances. References (b) and (c) provide specific pass-fail criteria for transportation.

7.2 Rather than a 50% point, in some cases the maximum force level at which 20 consecutive "No-Fires" occurs may be required. In this instance, the test preparation is identical but force levels are increased or decreased on a linear scale.

8. NATIONAL REFERENCES:

a. Allied Ordnance Publication -7 (AOP-7), Annex 1, *Description of Tests Used for the Qualification of Explosive Materials for Military Use*.

b. TB 700-2, *Department of Defense Explosives Hazard Classification Procedures*. Also known as NAVSEAINST 8020.8B, Air Force TO 11A-1-47, and DLAR 8220.1.

c. *Recommendations on the Transport of Dangerous Goods: Manual of Tests and Criteria*, United Nations, New York.

MIL-STD-1751A

Method 1022

Friction, Steel/Fiber Shoe

1. TYPE OF TEST: Friction

2. **PURPOSE:** This test is used to determine the sensitivity of a substance when subjected to a sliding frictional force.

3. **BACKGROUND:** None.

4. TEST ARRANGEMENT:

4.1 This pendulum friction device developed by the Bureau of Mines consists of a steel swinging shoe which is the bob of a pendulum. The "A" frame which supports the pendulum has two free bases which can be raised or lowered simultaneously. This allows the friction between the shoe and anvil and, hence, the number of swings of the pendulum to be controlled.

4.2 The anvil is a plate of steel with an upper face consisting of a smooth, polished surface. Across the central portion of this surface, three parallel grooves have been cut to prevent the test sample, which has been spread on the anvil, from being brushed off the anvil by the movement of the shoe across it.

4.3 A steel shoe or one faced with red-hair fiber (called the "hard-fiber-faced shoe") may be used. This facing is fixed permanently to the face of the particular shoe to which it is attached.

4.4 An automatic tripper is used to allow the shoe to be dropped upon the anvil from any desired vertical height ranging from 50 to 200 cm. Height of drop normally used is 100 cm.

4.5 This test should be conducted in a temperature controlled room so that the temperature of the anvil and shoe is $70 \pm 5^{\circ}\text{F}$.

5. PROCEDURE:

5.1 Before beginning the trials with the test explosive, test the shoe using the empty anvil to ensure that the shoe is adjusted squarely with the anvil. The apparatus should be adjusted such that, when loaded with weights, the shoe shall swing across the face of the anvil 18 ± 1 times before coming to rest. The adjustment is made by operating the turnbuckle that raises or lowers the "A" frame.

5.2 With the device properly adjusted, spread 7.0 ± 0.1 grams of the test explosive in an even layer in and about the three grooves in the anvil. The shoe is then released and the test result is noted.

5.3 Twenty trials should be conducted using the steel shoe or fiber shoe. To pass, the test material using the steel shoe should not react in any of the twenty trials.

5.4 After the pendulum has stopped swinging, any explosive remaining is brushed off and the faces of the shoe and anvil are cleaned thoroughly with a suitable solvent. The shoe and the anvil are rubbed with Carborundum cloth to remove any adherent gritty matter or to smooth any roughness caused by the impact of the shoe on the soft steel anvil.

MIL-STD-1751A

6. RESULTS AND DATA:

6.1 The following information shall be reported for this test:

- a. Shoe type (steel or fiber)
- b. Initial height of the pendulum
- c. Metric being reported (usually threshold initiation level (TIL))
- d. Criterion for determining go vs. no-go
- e. Number of trials per test result
- f. Number of replications of the test
- g. Sensitivity, in terms of reaction observed, of the candidate material
- h. Sensitivity, in terms of reaction observed, of reference standards.

6.2 Any type of explosion, burning, crackling, or scorching is considered a positive reaction.

6.3 Some typical results (reference (b)) are listed below:

<u>Material</u>	<u>Steel Shoe</u>	<u>Fiber Shoe</u>
Ammonium Perchlorate	Snaps	Unaffected
RDX	Explodes	Unaffected
Lead Azide	Explodes	N/A

7. SUPPLEMENTARY INFORMATION: None

8. NATIONAL REFERENCES:

a. Munroe, Charles E. and Tiffany, J.E., *Physical Testing of Explosives at the Bureau of Mines Explosives Experiment Station, Bruceton, PA.* U.S. Dept. of Commerce, Bureau of Mines, Bulletin 346, 1931. pp.78-84.

b. *Engineering Design Handbook Explosive Series Properties of Explosives of Military Interest.* U.S. Army Material Command, Washington, D.C. AMCP-706-177. January 1971, pp 26, 69, 182.

MIL-STD-1751A

Method 1023

Roto-Friction Test

1. TYPE OF TEST: Friction

2. PURPOSE: This test is used to determine the sensitivity of a substance when subjected to a sliding frictional force.

3. BACKGROUND: The test was developed at the Naval Surface Warfare Center, Crane Division as an improved test for measuring friction sensitivity. Reference (a) provides a detailed description of the test.

4. TEST ARRANGEMENT: The test equipment consists of the following components:

4.1 Sample holder: 1-inch tool steel cube (or similar shape with equivalent mass) with 0.25 ± 0.01 -inch diameter, 0.25 ± 0.01 -inch-deep recess bored centered in one side. If the shape of the block permits, recesses may be placed on multiple sides to increase life of the block.

4.2 Friction rod: 0.25 ± 0.01 -inch-diameter tool steel, powered by a drill press or similar mechanism capable of permitting vertical motion without affecting the rotational velocity, capable of turning the rod at a free-running speed of 4800 ± 100 RPM, and with sufficient power to maintain this speed to within 100 RPM when the rod is lowered onto the sample

4.3 Normal force weights: 25.0 ± 0.5 pounds of weight shall be added to the spindle which lowers the friction rod. Any mechanism that is designed to automatically return the spindle to its upper position shall be disabled, but the ability to raise and lower the spindle shall remain. The weights shall be permanently mounted.

4.4 Torque measurement device: The measurement of applied force transmitted through the sample is made by measuring the torque applied to the sample holder. This measurement may be made by using a torque meter or other direct torque measuring device, a counter-weighted torque cam (reading in degrees deflection or scaled to read torque), a load cell fitted to a torque arm, or other similar method. Observations may be made directly by the operator, by computer, by chart recorder or other suitable means. In the event that instrumented measurement and/or observation is used, a method for ensuring the accuracy of the readings shall be included. The torque measurement device shall include a dock for the sample holder which will securely hold the sample holder and keep it aligned with the friction rod.

4.5 Timer: The time from contact between the sample and the friction rod and the end of test shall be measured with a minimum accuracy of 0.1 second. This measurement may be made using a stop watch, electronic timer, computer, or other suitable means. A calibrated stop watch or electronic timer shall be used as a reference to verify accuracy if an instrumented method is used

4.6 Optional components:

- a. Robotic pick-and-place unit for sample insertion and removal.
- b. Pneumatic, electric or other remotely powered mechanism for raising the spindle, provided such mechanism does not interfere with spindle when fully lowered.

5. PROCEDURE:

5.1 Place a 30 ± 5 mg sample of the composition in the recess of the sample holder. Raise the spindle and place the sample holder in the dock on the torque measurement device. Activate the drive motor for the friction rod. Slowly lower the friction rod until it rests on the sample with full force of the normal force

MIL-STD-1751A

weights. Start the timer at the moment the rod contacts the surface of the sample. Observe and record the output of the torque measurement device until the sample reacts or 60 seconds has elapsed. Stop the timer at that moment and raise the spindle. Stop the friction rod and remove the sample holder. The sample rod should be cleaned between runs to ensure a uniform surface is presented to each specimen. If the torque measurement is not being recorded automatically, record the operator's observations immediately.

5.2 In the event that an initiation occurs within 2 seconds, the speed of the friction rod may be reduced. The use of an alternate speed, and the speed employed, shall be a part of the reported data and of any historical records.

6. RESULTS AND DATA:

6.1 The following information shall be reported for this test:

- a. Dimensions of sample holder cavity and friction rod
- b. Mass of normal force weights
- c. Method of measuring torque
- d. Method of obtaining time to reaction
- e. Metric being reported (e.g., 50% initiation level or threshold initiation level (TIL))
- f. Number of trials per test result
- g. Number of replications of the test
- h. Sensitivity, in terms of energy and level of reaction, of the candidate material
 - i. The energy value is calculated by multiplying the time to reaction by the torque observed. In the event that the torque reading is unstable during the test, the average torque should be used whenever possible. If it is not possible to obtain an average value then the reading at the moment of reaction shall be used. Integration of the area under a Time-vs-Force curve is preferable, and any such data plots obtained, or the means to readily reproduce them, should be kept as permanent historical data.
 - ii. Reaction levels for "Fire"
 - (a) Fire = Total or nearly total rapid consumption of sample, usually accompanied by an audible report
 - (b) Spark = Partial consumption which throws off spark(s) and may or may not have some audible component
 - (c) Burn = Slow consumption of some or all of sample with no audible report
 - iii. Reaction levels for "No-Fire"
 - (a) Melt = Sample material melts but does not initiate; considered a physical state change only
 - (b) Glaze = Surface of material glazes or hardens over; considered a physical state change only
 - (c) None = No detectable initiation or change in physical state occurs
- i. Sensitivity, in terms of energy and level of reaction, of reference standards

6.2 The results are reported as "No-Fire..." or "Fired at a torque of ___ lbf-foot and at ___seconds."

7. SUPPLEMENTARY INFORMATION: Class 7 PETN can be used as a reference standard material against which the results will be compared. A second reference material is required. It should be chosen so that the 50% point for the candidate explosive falls between the values for the two references.

MIL-STD-1751A

8. NATIONAL REFERENCES:

a. Armour, Carl, and Smith, Lloyd A., *The Invention of a New Type of Friction Sensitivity Apparatus*, U. S. Naval Weapons Support Center, Crane, Indiana RDTR No. 60, 11 June 1965. U.S. National Technical Information Service, Springfield, VA, AD 617382.

MIL-STD-1751A

Method 1024**BAM Friction Test****1. TYPE OF TEST:** Friction

2. PURPOSE: This test is used to determine the sensitivity of a substance when subjected to a sliding frictional force.

3. BACKGROUND: The BAM (Bundesanstalt für Materialprüfung) small friction tester, manufactured by the Julius Peters Company of Berlin, Germany, is used to measure the response of energetic materials to a friction stimulus generated between two roughened porcelain surfaces. Results are expressed numerically (as a 50% point in newtons (N)) which allows for a relative sensitivity ranking. Liquids and pasty substances are generally not tested due to their lubricating tendencies and resulting low heat development that is usually insufficient to cause a reaction.

4. TEST ARRANGEMENT:

4.1 The BAM apparatus, as shown in Figure 1, consists of a reciprocating sample table which holds a porcelain sample plate and a lever arm to which is attached a porcelain pin. Weights of varying mass are attached at different distances on the lever arm to adjust the force applied between the porcelain pin and plate. The sample is placed between the pin and plate. The sample table is driven by an eccentric arm attached to a geared-down electric motor which executes one revolution of the eccentric arm (one full cycle of reciprocating motion in the horizontal direction) when the motor is actuated

4.2 The porcelain pin is 15 mm long and 10 mm in diameter, with rounded ends of approximately 10 mm radius of curvature. The porcelain plates are 25-mm square and 5-mm thick. The total (peak-to-peak) displacement of the horizontal motion is 10 mm with the full cycle taking about one second to complete.

4.3 Weights supplied with the standard BAM apparatus provide a force on the pin of 0.5, 1, 2, 3, 4, 6, 8, 12, and 18 kg when suspended from the position nearest the pin. This can be increased by factors of 1.2, 1.4, 1.6, 1.8, and 2.0 by suspending the weights from successively more distant positions. Loads varying from 5 to 360 N can thus be realized.

4.4 Weights supplied with the small BAM apparatus provide a force on the pin of 0.01, 0.02, 0.05, 0.1, 0.2, 0.25, 0.3, 0.35, 0.4, 0.45 and 0.5 kg when suspended from the position nearest the pin. This can be increased by factors of 1.5 and 2.0 by suspending the weights from successively more distant positions. Loads varying from 0.1 to 10 N can thus be realized.

5. PROCEDURE:

5.1 Powdered samples are prepared by first sieving through a 0.5 mm mesh screen. Pressed, cast, and otherwise solid samples are crushed with a mortar and pestle prior to sieving. In some cases, shavings

MIL-STD-1751A

or thin machined disks of approximately 10 mm³ are also used. The sample weight in all cases is approximately 50 mg.

5.2 In conducting the test, the porcelain plate is secured on the sample table with the surface striations perpendicular to the direction of motion. The test sample is placed on a portion of the porcelain plate and the pin placed in the pin holder and lowered so that it is in contact with the sample. A major portion of the test sample is set in front of the pin so that most of it will come under the pin after the plate is set in motion. After the appropriate weight has been placed in the desired position on the load arm, the apparatus is actuated and the test conducted.

5.3 A positive result is judged to have occurred if there is evidence of ignition (flash or smoke), crackling, an explosion, or sparking. Negative results are indicated by a decomposition (slight black smear on the porcelain plate) and naturally, by no physical evidence of a reaction. A Bruceton method is then used with a sample size of 30 shots to determine a 50% point. This level is reported as a load in newtons.

6. RESULTS AND DATA:

6.1 The following information shall be reported for this test:

- a. Method of placing sample on the porcelain plate
- b. Metric being reported (50% initiation level or threshold initiation level (TIL))
- c. Criterion for determining go vs. no-go
- d. Number of trials per test result
- e. Number of replications of the test
- f. Sensitivity, in terms of force applied to the load arm, of the candidate material
- g. Sensitivity, in terms of force applied to the load arm, of reference standards.

6.2 Test results are compared to a Type I or II, Class 5 RDX standard conforming to MIL-DTL-398. Table I provides the results for several common explosives.

TABLE I. Friction sensitivity test results.

Explosive	Initiation Level 50% Point (N)*	Threshold Initiation Level, N (10/10 No-Fires)**
PETN, Class 4	56	60
Lead azide, Type I or II	10	
RDX, Type I or II, Class 1	96	115
RDX, 2.5 μ	128	
HMX, Grade B, Class 1	80	108
TNT, Type I or II	> 360	112
Composition B, Type I	> 360	112 (8/8TIL)

* Data from AFRL/MNME

MIL-STD-1751A

7. SUPPLEMENTARY INFORMATION:

7.1 This test has also been adopted by the United Nations as a standardized procedure, reference (b), for the hazard classification of explosive substances. Reference (b) provides specific pass-fail criteria for transportation.

7.2 Rather than a 50% point, in some cases the maximum force level at which 10 consecutive "No-Fires" occurs may be reported. Representative values of the threshold initiation limit (TIL) are given in Table I. Reference (c) states that the 50% point shall be reported.

7.3 Table II provides the friction load table for the various combinations of weights and notches available for the standard BAM friction apparatus. Table III provides the friction load table for various combinations of weights and notches available for the small BAM friction apparatus.

8. NATIONAL REFERENCES:

a. Harris, J., *Friction Sensitivity of Primary Explosives*, ARLCD-TR-82012, Picatinny Arsenal, Dover, NJ, September 1982.

b. *Recommendations on the Transport of Dangerous Goods, Tests and Criteria*, United Nations, New York.

c. NATO STANAG 4487, *Friction Sensitivity Tests for the Qualification of Explosives for Military Use*.

MIL-STD-1751A

TABLE II. Standard BAM friction load table.

Weight No.	Notch	Load (N)	Weight No.	Notch	Load (N)
1	1	5	4	6	60
1	2	6	5	4	64
1	3	7	5	5	72
1	4	8	5	6	80
1	5	9	6	3	84
1	6	10	6	4	96
2	2	12	6	5	108
2	3	14	7	3	112
2	4	16	6	6	120
2	5	18	7	4	128
2	6	20	7	5	144
3	2	24	7	6	160
3	3	28	8	3	168
4	1	30	9	1	180
3	4	32	8	4	192
3	5	36	8	5	216
3	6	40	8	6	240
4	3	42	9	3	252
4	4	48	9	4	288
4	5	54	9	5	324
5	3	56	9	6	360

Weight No.	1	2	3	4	5	6	7	8	9
Mass (g)	213	493	1053	1614	2174	3293	4414	6655	10005

MIL-STD-1751A

TABLE III. Small BAM friction load table.

Weight No.	Notch	Load (N)	Weight No.	Notch	Load (N)
1	1	0.1	8	1	3.5
1	2	0.15	6	2	3.75
1	3	0.2	5	3	4
2	3	0.3	7	2	4.5
2	3	0.4	6	3	5
3	1	0.5	8	2	5.25
3	2	0.75	7	3	6
3	3	1	10	2	6.75
4	2	1.5	8	3	7
4	3	2	9	3	8
6	1	2.5	10	3	9
5	2	3	11	3	10

Weight No.	1	2	3	4	5	6	7	8	9	10	11
Mass (g)	5.3	10	25	49.8	99.3	124.2	149.4	174.7	199.8	224.4	249.4

MIL-STD-1751A

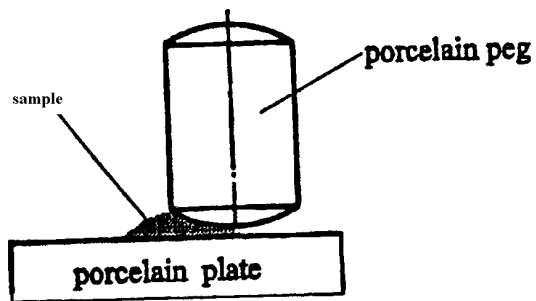
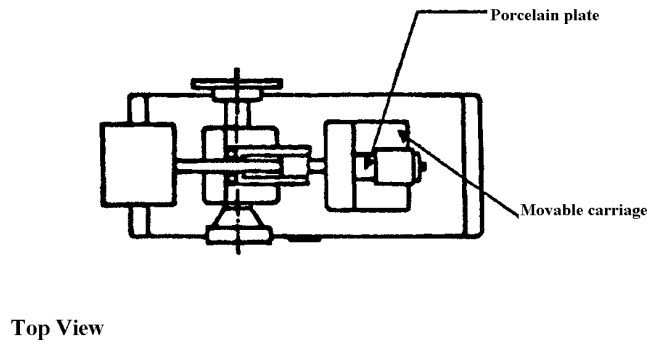
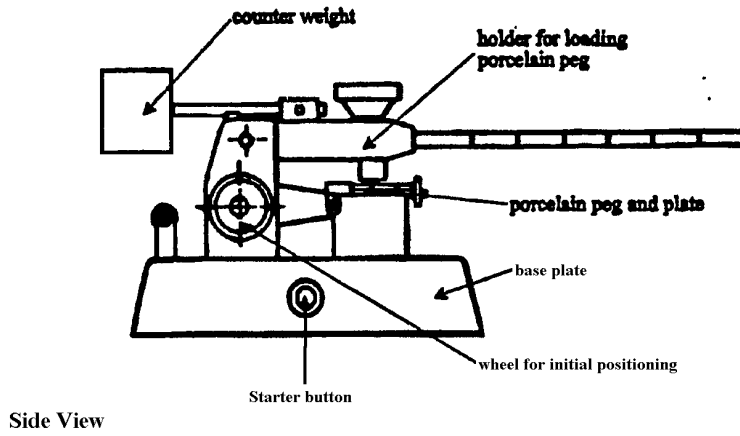

FIGURE 1. BAM friction test assembly.

MIL-STD-1751A

Group 1030
Test Methods
Electrostatic Discharge Sensitivity

MIL-STD-1751A

Method 1031

**Electrostatic Discharge Sensitivity Test
(Naval Surface Warfare Center (NSWC) Method)****1. TYPE OF TEST:** Electrostatic Discharge

2. PURPOSE: This test determines the energy threshold required to ignite explosives by electrostatic stimuli of varying intensities. Material response data obtained can then be used to characterize the probability of initiation due to electrostatic discharge (ESD) events.

3. BACKGROUND: The test apparatus described herein is identical to the Model 150 ESD sensitivity tester developed by Hercules Aerospace Company.

4. TEST ARRANGEMENT:

4.1 The apparatus consists of a series of capacitors, an electrode control assembly with a pointed steel electrode, and a sample holder where the explosive is loaded. After being placed in the sample chamber, the explosive is subjected to an electrostatic spark discharge which generates a consistent energy level for each discharge capacitance selected. By varying the capacitance in the discharge circuit, the energy level of the spark discharge may be controlled over approximately three orders of magnitude. Both the energy level below which there is no decomposition reaction and the probability of initiation for a given energy level can be determined for the explosive sample.

4.2 The power supply is designed to provide a single, regulated output of 5 kilovolts direct current (kVdc) at 10 milliamperes to charge the capacitors. The capacitor bank consists of up to 12 capacitors which vary in capacitance from 0.0001 to 0.5 μ F and are rated for 10 kV working voltage. Each of the capacitors is wired to a capacitor selector switch which allows only one of the capacitors to discharge at a time. The discharge apparatus consists of a needle electrode and a grounded sample post which form a point-to-plane electrode geometry. The needle electrode is connected to a Teflon push rod which allows movement of the electrode towards the sample holder post.

5. PROCEDURE:

5.1 Approximately 50 mg of the explosive sample should be placed in a thin layer in the sample holder. Solid samples should be cut to a minimum dimension of 0.625-inch square or 0.625-inch diameter and microtomed to a thickness of 0.033 ± 0.004 inch. Powder samples should be sieved to determine the particle size of the sample. Hygroscopic or granular materials should be dried in an oven at 120°F or vacuum desiccated to remove any moisture prior to testing.

5.2 The selected capacitor is charged to the selected voltage by means of the power supply. The test is begun at the 8.33 joule (0.5 μ F) level. The needle is set a fixed distance from the cathode. If results are negative, i.e., no reaction, the test is continued until 20 consecutive no-gos are reported. If the test sample has a positive result, i.e., flash, spark, burn, odor, or noise other than instrument noise, then testing should be performed at the next lower level until 20 consecutive no-gos are reported. The test is normally conducted at 5 kVdc at an ambient temperature between +65 and +90°F, and a relative humidity not exceeding 40 percent. In conjunction with the test sample, a reference standard such as Class 5 RDX or PETN should be

MIL-STD-1751A

tested at the same time.

6. RESULTS AND DATA:

- 6.1 The following information shall be reported for this test:
- a. Method of loading the sample into the test fixture
 - b. Description of the test fixture, including materials of construction and dimensions
 - c. Specific procedure for conducting the test, including the method for setting the position and the distance of the needle from the cathode when discharge occurs
 - d. Criteria used to determine go/no-go
 - e. Circuit diagram for the apparatus used
 - f. Actual or nominal capacitance associated with the energy levels tested
 - g. Maximum energy level (Threshold Initiation Level (TIL)) in joules that can be applied without causing a reaction in twenty consecutive trials.
 - h. Metric being reported (50% initiation level or threshold initiation level (TIL))
 - i. Number of trials per test result
 - j. Number of replications of the test
 - k. Method of data analysis (e.g., Bruceton)
 - l. Sensitivity, in terms of energy, of the candidate material
 - m. Sensitivity, in terms of energy, of reference standards
 - n. Summary of results of all other energy levels tested

6.2 After the capacitor has been charged to the applied potential (5kV), the capacitor will hold that charge for a significant period of time provided that the unit is functioning normally and the relative humidity is low. In high humidity conditions, surface moisture on the wires and capacitors in the unit may produce sufficient surface currents to partially discharge the capacitors before the sample can be tested. The energy, E , available for discharge may be determined by the relationship $E = CV^2/2$ where C = capacitance (μF) and V = applied voltage (kV). The total capacitance in the circuit is the combined values of the capacitor, wires, and electrode. The effective capacitance of the discharge circuit should be checked periodically to correct calculated energy levels for any significant changes in capacitance. Changes could be caused by deterioration of the capacitors over time or changes in the configuration of the electrodes. Table I provides actual capacitance and energy levels of the specific test apparatus located at the NSWC site. Table II presents typical test results when using the apparatus described herein.

7. **SUPPLEMENTARY INFORMATION:** None.

8. NATIONAL REFERENCES:

- a. Operating Manual for Model 150 ESD Sensitivity Tester, Hercules Aerospace Company, Allegany Ballistics Laboratory, Rocket Center, West Virginia

TABLE I. Energy levels for specific capacitor size.

MIL-STD-1751A

Nominal Capacitance (μF)	Actual Capacitance (μF)	Energy Level (joules) @ 5kV
0.5	0.498	6.225
0.25	0.251	3.140
0.1	0.103	1.290
0.05	0.051	0.640
0.02	0.0195	0.240
0.01	0.0099	0.120
0.005	0.0057	0.070
0.002	0.0022	0.030
0.001	0.0014	0.017
0.0005	0.0009	0.011
0.0001	0.0005	0.006

TABLE II. Typical test data.

Test Sample	Threshold Level (joules)	50% Point (joules)
HMX, Class 1	0.165	NA
RDX, Class 1	0.095	0.162
TNT	1.72	NA
PETN	0.095	NA

MIL-STD-1751A

Method 1032**Electrostatic Discharge Sensitivity Test
(ARDEC (Picatinny Arsenal) Method)****1. TYPE OF TEST:** Electrostatic Discharge

2. PURPOSE: This test determines the energy threshold required to ignite explosives by electrostatic stimuli of varying intensities. Material response data obtained can then be used to characterize the probability of initiation due to electrostatic discharge (ESD) events.

3. BACKGROUND: This test is designed to screen candidate booster and main charge explosives for ESD sensitivity and not to rank the sensitivities of such materials.

4. TEST ARRANGEMENT:

4.1 The approaching electrode electrostatic apparatus consists of a charging circuit and an approaching electrode assembly. The approaching electrode assembly is a spring-operated device in which the upper electrode (needle) is lowered to a preset distance above the lower (cathode) electrode and immediately raised again to its initial position. Adjustments to the gap length are made by raising or lowering the lower electrode.

4.2 The upper portion of the lower electrode is a detachable solid cylinder of hardened steel which serves as the sample holder. A nylon or polyethylene washer of 0.049 ± 0.014 inch thick by 0.13 to 0.16 inch inner diameter is fastened to the top of the steel cylinder (double adhesive tape may be used). The powder sample is placed in the center of the washer. Electrical insulating or mylar tape approximately 0.075 inch thick is placed over the sample opening to confine the powder.

4.3 The charging circuit consists of a variable high-voltage power supply (25 kV), a capacitor-charging circuit, and an electrostatic voltmeter. The circuit is designed so that the appropriate low-inductance, high voltage capacitance, from 0.00025 to 0.02 μF , can be connected in the circuit. The storage capacitors are connected to the high-voltage source only when the approaching electrode is in the raised position. As soon as the approaching electrode starts to move downward, the high voltage contact is broken, thus disconnecting the high side of the capacitor from the charging source during discharge. The capacitor output is connected to the approaching electrode assembly.

5. PROCEDURE:

5.1 The electrostatic sensitivity test is divided into two parts. Part I is a screening test devised to distinguish between those materials which are relatively insensitive to electrostatic discharges from those which are relatively sensitive. Part II is a more intensive procedure used to rank or to determine the energy required to ignite the sensitive materials.

5.2 *Part I:*

5.2.1 The energy for this test is fixed at 0.25 joules. In this case, a 0.02 μF capacitor is connected to the discharge circuit and charged to 5.0 kV. The electrode spacing (gap) is set to 0.007 inch. Approximately 30 mg of the test sample is placed into the hole of the washer fastened to the top of the

MIL-STD-1751A

sample holder. In general, there should be sufficient sample to fill the washer. Electrical insulating or mylar tape is then placed over the sample opening to confine the powder.

5.2.2 The charged upper electrode is released and moves downward to the preset gap distance. The needle will puncture the tape, penetrate the sample materials, discharge through the interstices of the material, and rise again to its initial position. (The threshold voltage for gap breakdown will determine the distance where the needle will be above the base electrode when the discharge occurs.) A positive result is defined as a flash, spark, burn, or noise other than instrument noise.

5.2.3 If no reaction occurs, repeat the procedure until no reaction is obtained in 20 trials. The material is recorded as having passed the electrostatic test if there are no reactions in the 20 consecutive trials at the 0.25 joule level (0.02 microfarad capacitor charged to 5.0 kV). If a reaction is obtained at any point in the above mentioned test, the test is discontinued and the procedure of 5.3 is used.

5.3 *Part II*: The starting capacitance is usually the largest value and the starting voltage is 5.0 kV unless more efficient values based on experience are known. Repeat the procedure in Part I, 5.2 above. If a reaction is obtained, the energy is reduced by decreasing the potential on the capacitor in 500 V increments and the above procedure repeated. The voltage is reduced until the charging voltage is 2500 V and then the next lower capacitance is selected. When an energy is reached where there is no reaction, repeat the procedure at that energy until no reaction is obtained in 20 consecutive trials. The results are reported as "no reaction at XX joules."

6. RESULTS AND DATA:

6.1 The following information shall be reported for this test:

- a. the method of loading the sample into the test fixture
- b. a description of the test fixture, including materials of construction and dimensions
- c. a circuit diagram for the apparatus used.
- d. criteria used to determine go/no-go
- e. metric used for reporting sensitivity (e.g., 50% point, threshold initiation limit)
- f. protocol used for conducting the test (Part I or Part II above)
- g. number of trials per test series
- h. number of replications of the test series
- i. results for the candidate material
- j. results for reference standards

6.2 Test results for protocol performed according to Part I (Section 5.2) shall be pass or fail at 0.25 joules. No reaction in twenty out of twenty trials is a pass. Any reaction in 20 trials is a fail.

6.2 Test results for sensitive materials, tested with the protocol given in Part II (Section 5.3 above) are reported as the maximum energy level in joules that can be applied without causing a reaction in 20 consecutive trials. The energy, E , available for discharge may be determined by the relationship $E = CV^2/2$ where C = capacitance (μF) and V = applied voltage (kV). The total capacitance in the circuit is the combined values of the capacitor, wires, and electrode. The effective capacitance of the discharge circuit should be checked periodically to correct calculated energy levels for any significant changes in capacitance. Values for three primary explosives are:

MIL-STD-1751A

<u>Primary Explosive</u>	<u>Energy for 0/20 (Millijoules)</u>
Basic Lead Styphnate	<0.2
RD 1333 Lead Azide	4.7
Tetracene	28.0

7. SUPPLEMENTARY INFORMATION: Test results can also be reported as the 50 percent point in joules which causes a sample to fire 50 percent of the time. This is determined by the Bruceton "Up-and-Down" procedure. In this case, the voltage is raised or lowered in 500 V increments.

8. NATIONAL REFERENCES:

a. Kirshenbaum, M. S., *Response of Primary Explosives to Gaseous Discharges in an Approved Approaching Electrode Electrostatic Sensitivity Apparatus*, PATR-4955, Picatinny Arsenal, October 1976.

MIL-STD-1751A

Method 1033**Electrostatic Discharge Sensitivity Test
(Naval Air Warfare Center (NAWC) Method)****1. TYPE OF TEST:** Electrostatic Discharge

2. PURPOSE: This test determines the energy threshold required to ignite explosives by electrostatic stimuli of varying intensities. Material response data obtained can then be used to characterize the probability of initiation due to electrostatic discharge (ESD) events.

3. BACKGROUND: The electrostatic test machine was designed and fabricated at China Lake, and was based on the research work undertaken under U.S. Bureau of Mines Sponsorship. The test is designed to simulate an electrostatically charged person or object discharging through a thin layer of sample to a grounded conductive surface.

4. TEST ARRANGEMENT:

4.1 The apparatus, shown in Figure 1, consists of a single capacitor, an electrode control assembly with a pointed steel electrode, and a sample holder where the explosive is loaded. After being placed in the sample chamber, the explosive is subjected to an electrostatic spark discharge which generates a consistent energy level for each discharge capacitance selected. By varying the capacitor in the discharge circuit, the energy level of the spark discharge may be controlled over approximately three orders of magnitude. Both the energy level below which there is no decomposition reaction and the probability of initiation for a given energy level can be determined for the explosive sample.

4.2 The power supply is designed to provide a single, regulated output of 5 kilovolts direct current (kVdc) at 10 milliamperes to charge a 0.02 μ F capacitor. The capacitor is wired to a capacitor selector switch which allows the capacitor to discharge. The discharge apparatus consists of a needle electrode and a grounded sample post which form a point-to-plane electrode geometry. The needle electrode is connected to a Teflon push rod which allows movement of the electrode towards the sample holder post.

5. PROCEDURE:

5.1 Approximately 50 mg of the explosive sample should be placed in a thin layer in the sample holder. Solid samples should be cut to a minimum dimension of 0.625 inch square or 0.625 inch diameter and microtomed to a thickness of 0.033 ± 0.004 inch. Powder samples should be sieved to determine the particle size of the sample. Hygroscopic or granular materials should be dried in an oven at 120°F or vacuum desiccated to remove any moisture prior to testing.

5.2 The selected capacitor is charged to the selected voltage by means of the power supply. The test is begun at the 8.33 joule (0.02 μ F) level. If results are negative, i.e., no reaction, the test is continued until 20 consecutive failures are reported. If the test sample has a positive result, i.e., flash, spark, burn, odor, or noise other than instrument noise, then testing should be performed at the next lower level until 20 consecutive failures are reported. The test is normally conducted at 5 kVdc at an ambient temperature of between +72

MIL-STD-1751A

and +80°F, and a relative humidity not exceeding 40 percent. In conjunction with the test sample, a reference standard such as Class 5 RDX or PETN should be tested at the same time.

6. RESULTS AND DATA:

6.1 The following information shall be reported for this test:

- a. a description of the test fixture, including materials of construction and dimensions
- b. the method of loading the sample into the test fixture
- c. a circuit diagram for the apparatus used.
- d. the actual or nominal capacitance associated with the energy levels
- e. specific procedure for conducting the test, including :
 - i. the method for setting the needle position
 - ii. the distance of the needle from the cathode when discharge occurs
- f. criteria used to determine go/no-go
- g. number of trials per test
- h. number of test replications
- i. sensitivity of the candidate explosive, in terms of the maximum energy level in joules that can be applied without causing a reaction in twenty consecutive trials.
- j. sensitivity of reference explosives, as above
- k. a summary of results of all other energy levels tested

6.2 Representative data for several explosives are given in Table I.

7. SUPPLEMENTARY INFORMATION: After the capacitor has been charged to the applied potential (5kV), the capacitor will hold that charge for a significant period of time provided that the unit is functioning normally and the relative humidity is low. In high humidity conditions, surface moisture on the wires and capacitors in the unit may produce sufficient surface currents to partially discharge the capacitors before the sample can be tested. The energy, E, available for discharge may be determined by the relationship $E = CV^2/2$ where C = capacitance (μ F) and V = applied voltage (kV). The total capacitance in the circuit is the combined values of the capacitor, wires, and electrode. The effective capacitance of the discharge circuit should be checked periodically to correct calculated energy levels for any significant changes in capacitance. Changes could be caused by deterioration of the capacitors over time or changes in the configuration of the electrodes.

8. NATIONAL REFERENCES: None.

MIL-STD-1751A

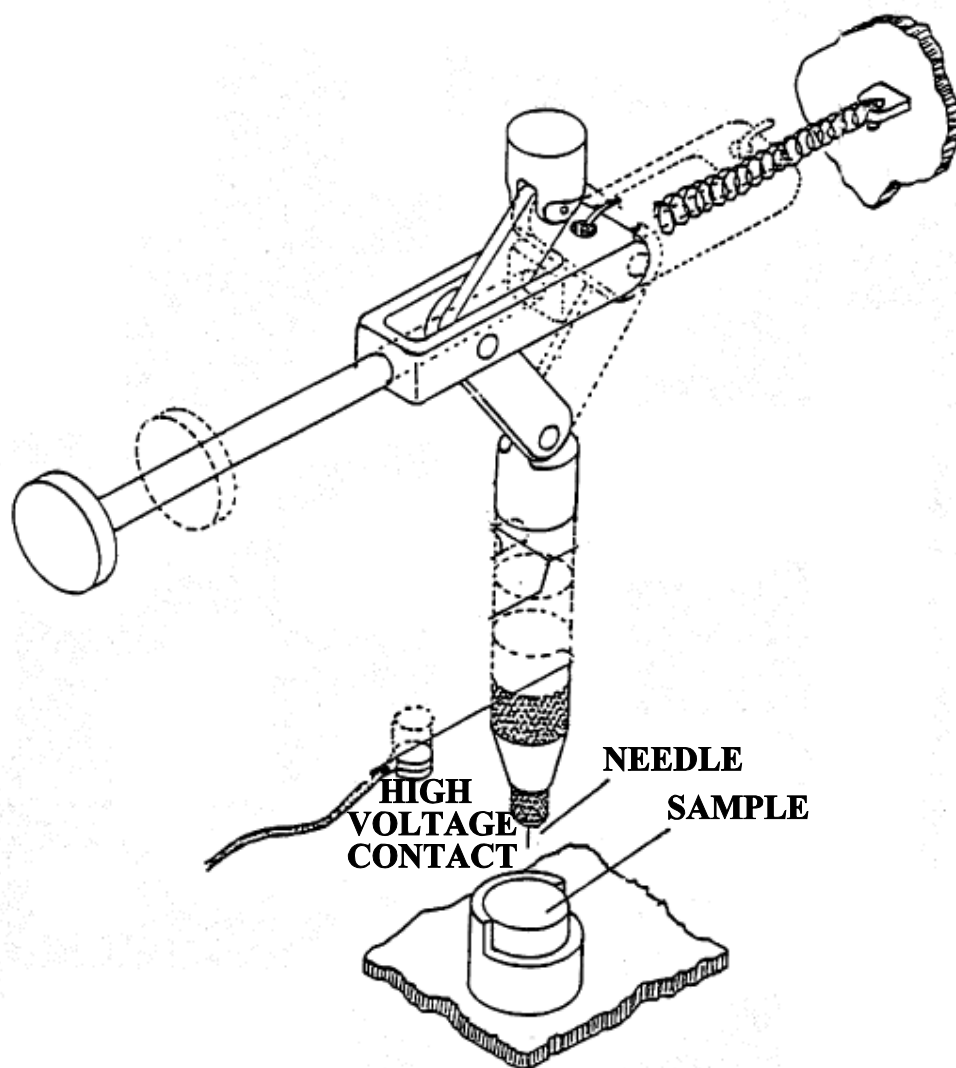

Figure 1. NAWC ESD Apparatus

MIL-STD-1751A

TABLE I. Results for several explosives tested by Method 1033.

Capacitance: 0.02 μ F Voltage: 5000 V	
Explosive	Result
RDX, Class I	10/10 No Fires @ 0.25J
RDX, Class II	10/10 No Fires @ 0.25J
RDX, Class V	10/10 No Fires @ 0.25J
PETN, Dupont Superfine (12 μ m)	10/10 No Fires @ 0.25J
HMX, Class I	10/10 No Fires @ 0.25J
TNT	10/10 No Fires @ 0.25J
Tetryl, Dup404	10/10 No Fires @ 0.25J
CH-6	10/10 No Fires @ 0.25J
TATB	10/10 No Fires @ 0.25J

MIL-STD-1751A

Method 1034

Electrostatic Discharge Sensitivity Test - Large Scale

1. **TYPE OF TEST:** Electrostatic Discharge - Large Scale

2. PURPOSE: This test determines the energy threshold required to ignite explosive billets by electrostatic stimuli of varying intensities. This test differs significantly from other procedures in that it evaluates electrostatic discharge (ESD) effects on processed charges orders of magnitude larger than those normally tested in the milligram size. The effect of multiple ESD pulses is also examined. Material response data obtained can then be used to characterize the probability of initiation due to ESD events.

3. BACKGROUND: This test was developed in France to characterize the response of explosive charges to single and multiple ESD pulses. It has been incorporated in a NATO standardization agreement for energetic material qualification (see reference (a)).

4. **TEST ARRANGEMENT:**

4.1 The test setup consists of a high voltage power supply, a high efficiency capacitor (34.7 nF) with independent coupling, an explosive sample, negative and positive brass electrodes, and high voltage cables. The positive electrode is a 10 mm diameter by 210 mm long brass rod, tapered to a 60° conical shape (see Figure 3), with the end in contact with the test charge. The negative electrode is a brass disk 110 mm in diameter by 5 mm thick.

4.2 Explosive samples are tested in one of two ways:

4.2.1 Bare billets, 90 mm in diameter by 90 mm long, with one face painted with a conductive silver lacquer. Cast explosive samples should be processed as they normally would be prepared in production. Pressed samples should be tested at the nominal working density at which they are expected to be used in applications.

4.2.2 Granular or powder samples should be placed in a polymethylmethacrylate (PMMA) container with 90 mm I.D., 102 mm O.D., and a length of 125 mm. A polyvinylchloride cover plate with a center hole for the electrode is then glued on top of the container.

4.2.3 Figures 1 through 4 provide diagrams of the test setup, power supply, electrodes, and sample containers

5. PROCEDURE: The explosive material is placed between a conical positive electrode and a negative plane electrode. The bare explosive sample or the one contained in the PMMA holder is subjected

MIL-STD-1751A

to a series of electrostatic discharges with a fixed intensity of 15.6 joules. This energy level is obtained by charging the selected capacitor to 30kV. After each discharge, the explosive material behavior is noted. Consecutive discharges are then repeated until an explosive reaction is observed or up to 30 discharges, whichever comes first. The test is then repeated in triplicate on two additional samples of the same energetic component.

6. RESULTS AND DATA:

- 6.1 The following information shall be reported for this test:
- a. the method of loading the sample into the test fixture
 - b. a description of the test fixture, including materials of construction and dimensions
 - c. a circuit diagram for the apparatus used.
 - d. protocol used for conducting the test
 - e. number of replications of the test series
 - f. results for the candidate material
 - i. number of discharges performed
 - ii. sample behavior (see below)
 - g. results for reference standards

6.2 Sample behavior is defined according to the following reaction levels:

- a. No reaction
- b. Rising of the cover with flash
- c. Fragmentation of the explosive billet
- d. Combustion/burning
- e. Detonation

6.3 The explosive sample is judged to have failed the test if the results of 6.2.c, 6.2.d, or 6.2.e above are noted on any one of the three samples after 30 ESD pulses are performed on each.

7. SUPPLEMENTARY INFORMATION: None

8. NATIONAL REFERENCES:

- a. NATO STANAG 4490, *Explosives, Electrostatic Discharge Sensitivity Test, Large Scale.*

MIL-STD-1751A

Group 1040
Test Methods
Explosive Shock Sensitivity

MIL-STD-1751A

Method 1041

**Explosive Shock Sensitivity Test
(NOL Large Scale Gap Test (LSGT) Method)****1. TYPE OF TEST:** Shock Sensitivity

2. PURPOSE: This procedure is applicable to explosives with an unconfined critical diameter of less than 1.4 inches. If there is any question as to whether the explosive to be tested meets this criterion, the critical diameter should be measured prior to conducting the LSGT.

3. BACKGROUND: This test has been used extensively for over thirty years to characterize the shock sensitivity of energetic compounds. To some extent, it is considered the “baseline” from which most other shock sensitivity tests have been developed.

4. TEST ARRANGEMENT:

4.1 A standard donor explosive provides an explosive shock pressure of uniform magnitude. The shock is transmitted to the explosive test sample (acceptor) through a barrier of inert material which functions as a well-calibrated attenuator. By varying the thickness of the barrier between the donor and the acceptor, the barrier length required to allow or prevent detonation of the acceptor is determined. A steel plate is used at the base of the acceptor to provide a clear indication of whether or not the acceptor detonates in the trial. By a series of trials, the thickness of barrier (gap) material that permits 50% of the acceptor samples to detonate is determined.

4.2 Specific details of the normal experimental assembly are shown in Figure 1. A detonator (#8 blasting cap or equivalent output) is used to initiate the standard donor which consists of two pressed 50/50 pentolite pellets with a density of 1.56 ± 0.01 g/cm³. The approximate weight of each pellet is 80.3 g. The gap between the acceptor and donor is provided by a series of polymethylmethacrylate (PMMA) disks or cards with variable thickness. Standard attenuator sizes are 0.010, 0.050, 0.100, 0.250, 0.500, 0.750, 1.00, and 1.50 inches. The acceptor is cast, pressed, or machined to fit a cold drawn, mild steel (SAE 1015-1040) seamless tube with 0.22-inch-thick walls and a length 5.5 inches. The ends of the acceptor are machined or cut so that they are flat and flush with the ends of the tube. A mild steel (e.g., SAE 1015 - 1026) witness plate is placed 0.063 inches below the end of the acceptor.

4.3 To assemble the test, a cardboard spacer is placed around the end of the acceptor tube. The spacer, (measuring 1.875-inch inside diameter, 2.0-inch outside diameter, and 0.75 inch long) is used to center the acceptor in a cardboard container into which all the test components (donor, PMMA spacers, and wooden block used to hold the detonator) are placed. The cardboard container measures 2.0-inch inside diameter by 2.23-inch outside diameter by 8.5 inches long. The spacer serves to hold the acceptor

MIL-STD-1751A

firmly in the center of the larger container and also to provide a stand-off of the charge from the witness plate. The entire assembly is then placed on a 6-inch square by 0.375-inch-thick steel witness plate which is used to determine whether a detonation has occurred

4.4 The test arrangement shown in Figure 1 is fully described in reference (a) and its calibration procedure is described in reference (b).

5. TEST PROCEDURE:

5.1 If possible, prior to testing, acceptor charges should be conditioned for a minimum of 8 hours at 75°F. A #8 blasting cap or equivalent output device is used to initiate the pentolite donor which transmits a shock wave through the PMMA gap and into the acceptor. If the transmitted shock initiates a reaction in the test material, the effect of that reaction is shown as damage to the witness plate. The plate is inspected after each shot with a positive result or "go" defined as a neat hole punched in the plate. An example of a negative result or "no-go" is a broken plate or one with a poor quality hole. Twelve charges are usually required to obtain the mean or 50% point.

5.2 For an unknown material, the first test is generally conducted at zero gap. If no detonation occurs, two additional tests are performed at zero gap. If a detonation occurs, the next test is conducted at 50 cards; and thereafter, the number of cards is doubled until a negative result, "no-go," is obtained. Subsequent tests are made by dividing in half the gap between the closest "go" and "no-go" until one positive and one negative result, differing by one card, can be obtained.

6. RESULTS AND DATA:

- 6.1 The following information shall be reported for this test:
- a. description of the initiation train (detonator, booster (if any) and donor charge)
 - b. material used for steel tube
 - c. gap material used (PMMA, cellulose acetate, or a combination)
 - d. result for the candidate explosive for 50% detonation probability
 - i. gap thickness in cards or inches
 - ii. pressure at the end of the gap
 - e. dimensions of the witness plate

6.2 The pressure in the gap material at the end of the gap is obtained from the calibration of the gap thickness for the donor system employed. The calibration data for a pentolite donor and PMMA gap are given in Table I, which can be used to convert from a gap length in inches to a pressure in kilobars.

6.3 The pressure at the end of the gap can be converted to a pressure in the acceptor explosive by the use of the shock Hugoniot relationship of the gap material and of the acceptor explosive.

MIL-STD-1751A

6.4 Results for some common explosives are shown in Table II. Reference (a) provides additional data on the results of shock sensitivity tests on a wide variety of compositions.

7. SUPPLEMENTARY INFORMATION:

7.1 The small stand-off (.063-inch gap) between the acceptor and the witness plate was introduced to prevent the witness plate from shattering and thereby facilitate interpretation of test results. The presence of the stand-off has no effect on the 50% point for Composition B although the punched witness plate from the standard test is somewhat more bent than that from the test run without the stand-off. PMMA was initially chosen as the gap material because (1) it is stable to changes in temperature and humidity, (2) it matches the impedance of solid non-porous test materials better than most other commonly used attenuators, and (3) it is much more convenient to use than molded wax. Additional advantage of PMMA, particularly over metal gaps, is that PMMA forms no damaging fragments. The latter situation complicates the estimation of the shock wave transmitted from the gap to the test material which has already been pre-compressed by the elastic wave. The disadvantage of PMMA is its viscoelastic behavior and the resultant uncertainty of its relaxation times. Hence, in the low pressure range there is still some uncertainty about whether a pressure lower than the equilibrium value should be used.

7.2 Some laboratories prefer to use witness plates with larger length and width, e.g., 9" square, to reduce the likelihood of shattering the witness plate. This is an acceptable variation.

7.3

8. NATIONAL REFERENCES:

a. Price, D, Clairmont, A. R., Jr., and Erkman, J.O., *The NOL Large-Scale Gap Test*. III. Compilation of Unclassified Data and Supplementary Information for Interpretation of Results, NOLTR 74-40, March 1974.

b. Erkman, J.O., Edwards, D.J., Clairmont, A.R., Jr., and Price, D., *Calibration of the NOL Large-Scale Gap Test; Hugoniot Data for Polymethyl Methacrylate*, NOLTR 73-15, April 1973.

MIL-STD-1751A

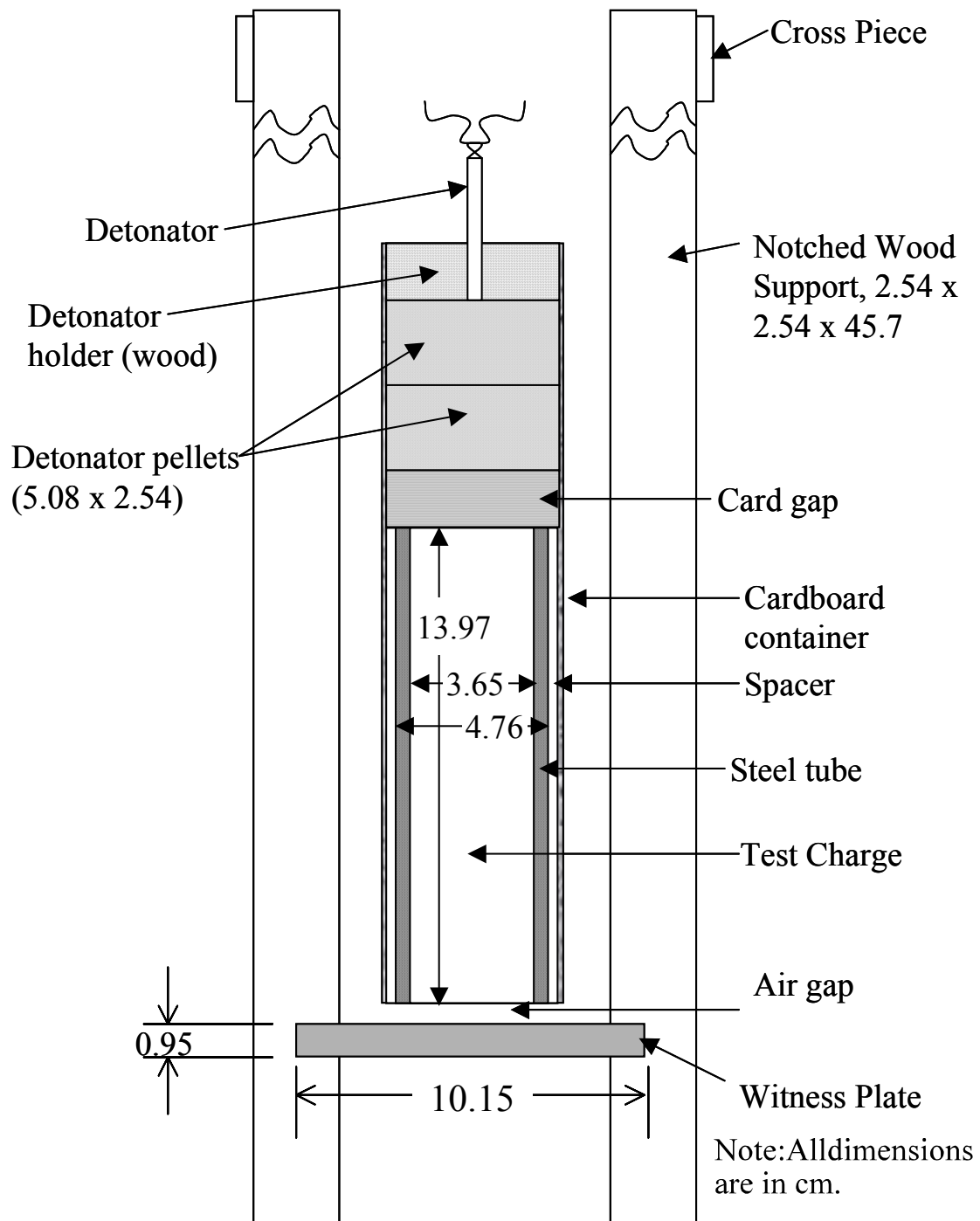

FIGURE 1. Cross-section of large-scale gap test assembly.

MIL-STD-1751A

TABLE I. NOL large scale gap test calibration data.

Calibration of NOL Large Gap Test for Lot 718 Pentolite

Number of cards in gap is sum of a number in first row and a number in the first column. One card is 0.01 inch; pressure in kilobars.

	0	1	2	3	4	5	6	7	8	9
0	213.1	202.5	192.9	184.2	176.3	169.2	162.7	156.8	151.4	146.5
10	142.0	137.9	134.1	130.6	127.3	124.3	121.6	119.0	116.6	114.4
20	112.3	110.4	108.5	106.8	105.2	103.7	102.2	100.9	99.6	98.3
30	97.2	96.0	95.0	93.9	92.9	92.0	91.1	90.2	89.3	88.5
40	87.7	86.9	86.2	85.4	84.7	84.0	83.3	82.6	82.0	81.3
50	80.7	80.1	79.5	78.9	78.3	77.7	77.1	76.6	76.0	75.5
60	74.9	74.4	73.9	73.3	72.8	72.3	71.8	71.3	70.8	70.3
70	69.8	69.3	68.9	68.4	67.9	67.5	67.0	66.6	66.1	65.7
80	65.2	64.8	64.3	63.9	63.5	63.1	62.6	62.2	61.8	61.4
90	61.0	60.6	60.2	59.8	59.4	59.0	58.6	58.2	57.8	57.4
100	57.1	56.7	56.3	55.9	55.6	55.2	54.9	54.5	54.1	53.8
110	53.4	53.1	52.7	52.4	52.1	51.7	51.4	51.0	50.7	50.4
120	50.1	49.7	49.4	49.1	48.8	48.5	48.2	47.8	47.5	47.2
130	46.9	46.6	46.3	46.0	45.7	45.4	45.2	44.9	44.6	44.3
140	44.0	43.7	43.4	42.8	42.2	41.6	41.0	40.5	39.9	39.4
150	38.9	38.3	37.8	37.3	36.8	36.3	35.8	35.4	34.9	34.4
160	34.0	33.6	33.1	32.7	32.3	31.8	31.4	31.0	30.6	30.2
170	29.9	29.5	29.1	28.7	28.4	28.0	27.7	27.3	27.0	26.7
180	26.3	26.0	25.7	25.4	25.1	24.8	24.5	24.2	23.9	23.6
190	23.3	23.0	22.8	22.5	22.2	22.0	21.7	21.5	21.2	21.0
200	20.7	20.5	20.3	20.1	19.8	19.6	19.4	19.2	19.0	18.8
210	18.6	18.4	18.2	18.1	17.9	17.7	17.5	17.4	17.2	17.0
220	16.9	16.7	16.5	16.4	16.2	16.1	15.9	15.8	15.6	15.5
230	15.3	15.2	15.1	14.9	14.8	14.7	14.5	14.4	14.3	14.1
240	14.0	13.9	13.8	13.7	13.5	13.4	13.3	13.2	13.1	13.0
250	12.9	12.7	12.6	12.5	12.4	12.3	12.2	12.1	12.0	11.9
260	11.8	11.7	11.6	11.5	11.4	11.3	11.3	11.2	11.1	11.0
270	10.9	10.8	10.7	10.6	10.6	10.5	10.4	10.3	10.2	10.2
280	10.1	10.0	9.9	9.8	9.8	9.7	9.6	9.5	9.5	9.4
290	9.3	9.3	9.2	9.1	9.1	9.0	8.9	8.9	8.8	8.7
300	8.7	8.6	8.6	8.5	8.4	8.4	8.3	8.3	8.2	8.1
310	8.1	8.0	8.0	7.9	7.9	7.8	7.8	7.7	7.7	7.6
320	7.6	7.5	7.5	7.4	7.4	7.3	7.3	7.2	7.2	7.1
330	7.1	7.0	7.0	7.0	6.9	6.9	6.8	6.8	6.7	6.7
340	6.7	6.6	6.6	6.6	6.5	6.5	6.4	6.4	6.4	6.3
350	6.3	6.3	6.2	6.2	6.2	6.1	6.1	6.1	6.0	6.0
360	6.0	5.9	5.9	5.9	5.8	5.8	5.8	5.8	5.7	5.7
370	5.7	5.6	5.6	5.6	5.6	5.5	5.5	5.5	5.5	5.4
380	5.4	5.4	5.4	5.3	5.3	5.3	5.3	5.2	5.2	5.2
390	5.2	5.1	5.1	5.1	5.1	5.1	5.0	5.0	5.0	5.0
400	5.0									

Note: Results are nominal for 0 to 39 cards.

MIL-STD-1751A

TABLE II. NOL large scale gap test results.

Explosive	Density (g/cm ³)	% TMD	50% Point Number of Cards	50 % Point Pressure* (kbar)
CH-6	1.70	95.5	267	11.0
COMP A-3	1.61	96.2	242	13.8
COMP B (Cast)	1.69 to 1.70	98.5 to 98.7	201 to 220	16.9 to 20.5
COMP C-4	1.56	98.4	192	22.8
H-6 (Cast)	1.75	97.6	197	21.5
LX-14	1.80	97.3	199	21.0
NQ	1.61	90.6	47	82.6
OCTOL 85/15	1.81	97.7	236	14.5
PBXN-7	1.79	95.0	217	17.4
PBXN-9	1.73	98.1	166 to 201	20.5 to 31.4
Pentolite 50/50 (Cast)	1.64	95.9	301	8.6
RDX	1.64	91.0	323	7.4
TATB	1.82	94.2	78	66.1
TETRYL	1.64	94.9	238	14.3
TNT (Cast)	1.58 to 1.61	95.7 to 98.1	108 to 198	21.2 to 54.1

* In the gap material

MIL-STD-1751A

Method 1042

**Explosive Shock Sensitivity Test
(NOL Small Scale Gap Test (SSGT) Method)****1. TYPE OF TEST:** Shock Sensitivity

2. PURPOSE: This test measures the sensitivity to detonation of an explosive exposed to an explosive-induced shock. This procedure is applicable to explosives with a critical diameter of less than 0.2 inch.

3. BACKGROUND:

3.1 The present small-scale gap test (SSGT) has evolved through several improvements. The original test used dextrinated lead azide as the donor explosive, an air gap as the attenuator, and "complete shatter" of a witness plate as the go/no-go criterion. The donor output was too small, the gap spacing was difficult to maintain, and the method of determining the result was ambiguous. In 1961, the test was redesigned to use an RDX donor and polymethylmethacrylate (PMMA) attenuator. In the original RDX donor, a 0.1 inch gap was left at the top for insertion of the detonator. Later in 1973, the donor was modified such that the RDX was pressed and then cut off flush with the top of the containing cylinder. Tests showed that this change had no significant effect on the donor output

3.2 A standard donor explosive system provides a small diameter explosive shock pressure of uniform magnitude. The shock is transmitted to the explosive test sample (acceptor) through a barrier of inert material which functions as a well-calibrated attenuator. By varying the thickness of the barrier between the donor and the acceptor, the barrier thickness required to allow or prevent detonation of the acceptor is determined. A steel dent block is placed at the base of the acceptor to provide an indication of whether or not the acceptor detonates in the trial. By a series of trials, the thickness of barrier (gap) material that permits 50% of the acceptor samples to detonate is determined.

4. TEST ARRANGEMENT:

4.1 Specific details of the experimental assembly are shown in Figure 1. The donor charge assembly consists of a brass cylinder 1.50 inches long, 1.00-inch outside diameter and 0.20-inch inside diameter, filled with Type II, Class 2 RDX, conforming to MIL-DTL-398, in eight increments. Seven increments of approximately 200 mg are pressed at 10,000 pounds per square inch (psi) to a density of $1.56 \pm 0.03 \text{ g/cm}^3$. The eighth increment or top-off weight of RDX is pressed to be flush with the top of the donor charge.

4.2 The eighth increment is also pressed at 10,000 psi. The donor charge is initiated by a No. 6 electric detonator (or equivalent output) positioned at one end in a plastic holder. The attenuator (gap) consists of PMMA disks, 1.00 inch in diameter, of varied thickness. The test explosive (acceptor) is pressed or extended into a brass cylinder identical to that containing the donor charge. The steel dent block is a disk, 3.00 inches in diameter and 1.50 inches thick.

4.3 For assembly, the donor, attenuator and acceptor are secured together with a peripheral wrap of

MIL-STD-1751A

masking tape. Other pieces of the tape are bridged over the whole assembly to prevent motion of the detonator and to keep the components aligned on the dent block.

5. PROCEDURE:

5.1 At firing, the detonation of the RDX donor charge sends a shock through the gap into the acceptor. If the transmitted shock initiates a reaction in the test material, the effect of that reaction is shown as damage to the dent block, which is recovered after the shot. The criterion for a positive result or "go" depends on the damage potential of the explosive under the test. A dent more than half the depth of the average dent produced by the test explosive, fired with no gap, is regarded as a "go". A smaller dent is a negative or "no-go". Dent depths are measured as the distance below the undisturbed metal behind the ring upset around the dent.

5.2 Usually, 25 charges are prepared for one shock sensitivity determination and assigned to the firing sequence in random order. First, two charges are fired with zero gap to determine a provisional dent threshold. Then 20 charges are fired in a Bruceton stair-step plan. If a shot is a "go", the next shot is fired with a thicker attenuator. If it is a "no-go", the next step is fired with a thinner attenuator. The remaining three are reserved in case of mistakes during the 20-shot run. If not required as replacements, they are also fired with zero gap.

5.3 Data are treated and results are given in gap reducing units, decibangs (dBg), defined as follows:

$$Y = 30 - 10 \log X$$

where Y is the shock strength in dBg and X is the PMMA gap in mils (0.001 in). The step size for the Bruceton sequence is 0.125 dBg. Some typical values for dBg vs. gap are listed in table I. Data are reduced by the "maximum likelihood" method described in reference (e) and briefly outlined in paragraph 7 below. This method uses actual barrier thicknesses, measured with a micrometer and converted to dBg, for each shot rather than the nominal dBg value of the corresponding level. This is an important improvement to the precision of the sensitivity measurement because the practical tolerances in the PMMA spacer thicknesses is about ± 0.05 dBg.

5.4 Acceptors are filled with the explosive under the test in eight equal increments pressed at the same pressure. The increment weight is selected so that the eighth increment partially fits into the cylindrical container. The excess is cut off flush with the end of the container. The container is weighed before and after filling, and the acceptor charge density is calculated to three decimal places.

5.5 When the SSGT is performed as part of the qualification of a pressed booster explosive, the acceptor charges are loaded at $16,000 \pm 1,000$ psi. In this case, 20 shots are fired at the 3.5 dBg level, and the explosive passes the test if no charge produces a dent greater than 0.002 inches deep.

5.6 When the SSGT is conducted to evaluate the shock sensitivity of a pressed granular explosive composition, test sequences are performed for each of a number of acceptor densities. A typical set would be the densities produced by pressing pressures of 4, 8, 16, 32, and 64 psi ($\times 10^3$), respectively.

MIL-STD-1751A

6. RESULTS AND DATA:

- 6.1 The following information shall be reported for this test:
- a. description of the initiation train (detonator, booster (if any) and donor charge)
 - b. pressure at which the sample pellets were pressed.
 - c. number of trials per test series
 - d. number of test series conducted
 - e. sensitivity of the candidate explosive
 - f. sensitive of reference explosives

6.2 Results are reported in terms of decibangs (dBg) required to produce 50% detonation probability. Table I shows dBg vs. gap thickness. A graph of this data is presented in Figure 2.

6.3 Results for some common explosives are shown in Table II. Reference (d) lists additional data on the results of the SSGT for several typical explosives over a range of pressed densities.

7. SUPPLEMENTARY INFORMATION:

7.1 A calibration of the shock wave pressure transmitted by various PMMA gap thicknesses is reported in reference (d). The results are summarized in the following equation:

$$\log P = 0.14 Y + 0.5232$$

where P is the shock pressure in kbar, and Y is the donor/attenuator value in dBg. This relationship holds in the range of 2 through 10 dBg. Values of the shock sensitivity (50% point) determined by the SSGT correlate well with those determined by the large-scale gap test (LSGT) at charge densities below 90% TMD. At lower porosities, the SSGT gives lower sensitivities and some reversals when comparing different explosive compositions.

8. NATIONAL REFERENCES:

a. Walker, G. R., Whitbread, E. G., and Hornig, D. C., ed. *Manual of Sensitiveness Tests*, Valcartier, Quebec, Canada: Canadian Armament Research and Development Establishment. Published for Tripartite Technical Cooperation Program (TTCP), Panel 0-2 (Explosive), Working Group on Sensitiveness, February 1966, pp. 144-151.

b. Ayres, J. N., *Standardization of the Small Scale Gap Test Used to Measure the Sensitivity of Explosives*, NAVWEPS Report 7342, 16 January 1961, Naval Surface Warfare Center, White Oak, MD 20903-5000.

c. Price, D. and Liddiard, T. P. Jr., *The Small-Scale Gap Test: Calibration and Comparison with the Large Scale Gap Test*, NOLTR 66-87, 7 July 1966, Naval Surface Warfare Center, White Oak, MD 20903-5000.

MIL-STD-1751A

d. Ayres, J. N., Montesi, L. J., and Bauer, R. J., *Small-Scale Gap Test (SSGT) Data Compilation: 1959-1972: Volume I, Unclassified Explosives*, NOLTR 73-132, 26 October 1973, Naval Surface Warfare Center, White Oak, MD 20903-5000.

e. Hampton, L. D. and Blum, G. D., *Maximum Likelihood Logistic Analysis of Scattered Go/No-Go (Quantal) Data*, NOLTR 64-238, 26 August 1965, Naval Surface Warfare Center, White Oak, MD 20903-5000.

TABLE I. dBg vs. gap thickness.

dBg	Gap Thickness (in.)
2.0	0.6310
2.5	0.5623
3.0	0.5012
3.5	0.4467
4.0	0.3981
4.5	0.3548
5.0	0.3162
5.5	0.2818
6.0	0.2519
6.5	0.2239
7.0	0.1995

MIL-STD-1751A

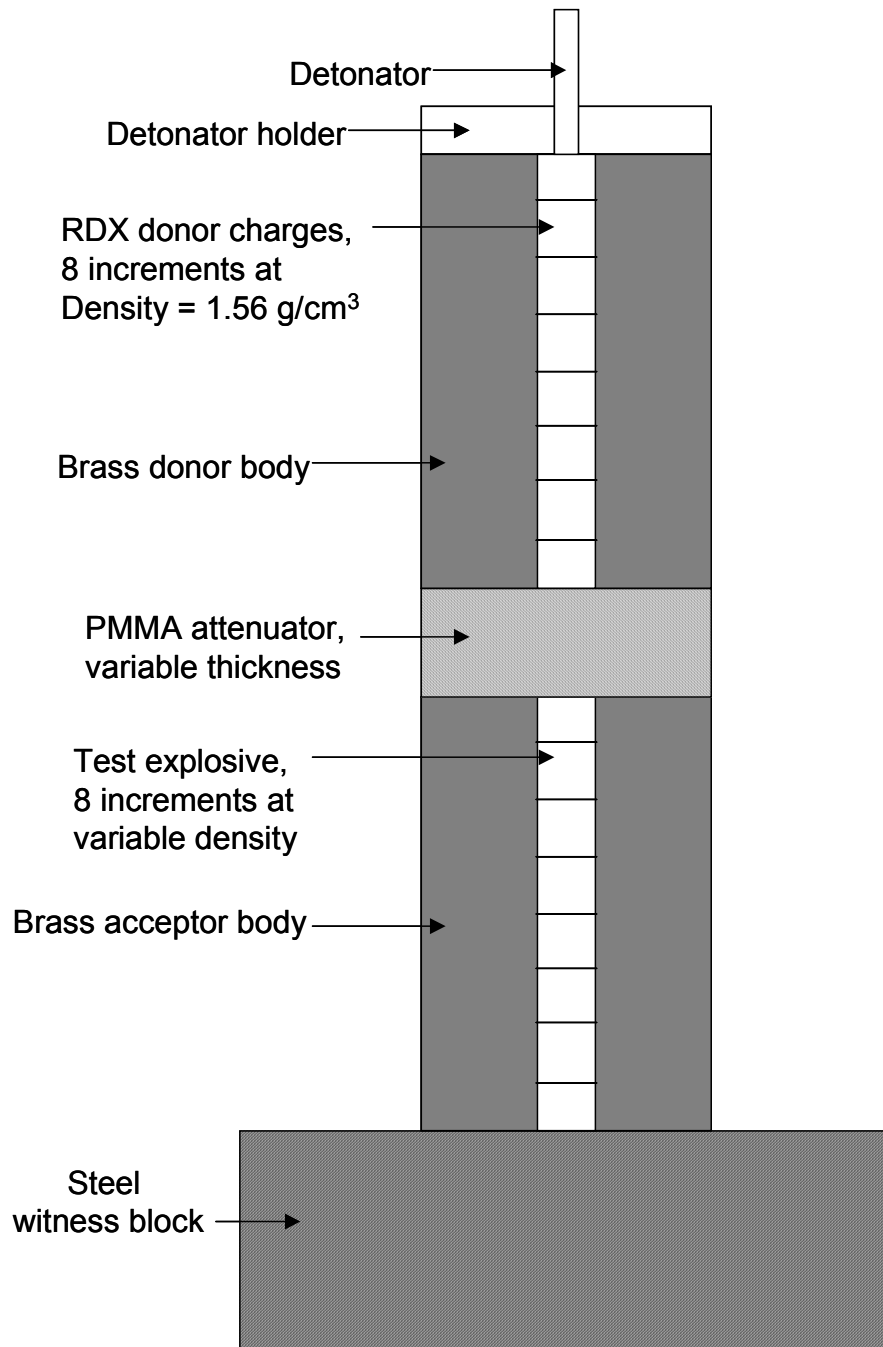

FIGURE 1. Small Scale gap test assembly.

MIL-STD-1751A

dBg vs. gap thickness

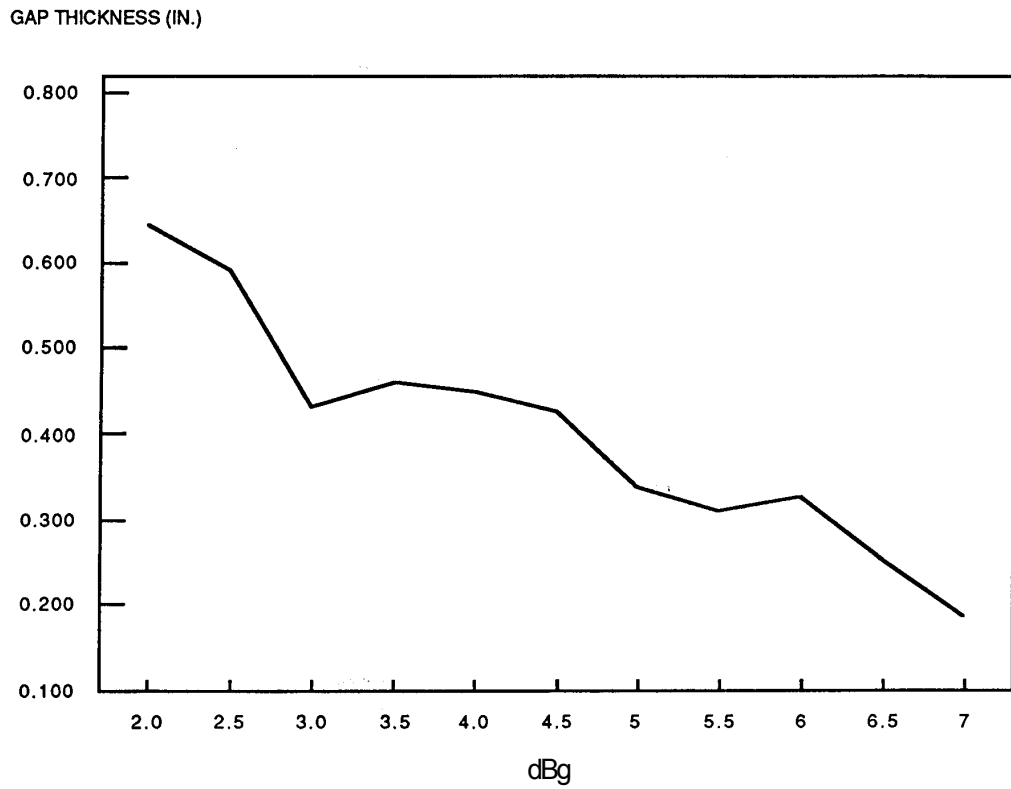

FIGURE 2. dBg vs. gap thickness.

MIL-STD-1751A

TABLE II. Small-scale gap test results.

Explosive	Load Pressure (psi x10 ³)	Density (g/cm ³)	% TMD	50% Point (dBg)
Lead Azide	4	2.535	53.8	-3.622
	8	2.775	58.9	-0.302
	16	3.074	65.3	-0.239
	32	3.361	71.4	-0.227
	64	3.663	77.8	-0.303
PETN	8	1.499	84.2	1.725
	16	1.600	89.9	2.468
	32	1.708	96.0	3.555
	64	1.775	99.7	4.998
RDX	10.0	1.546	85.8	3.250
	18.3	1.618	89.8	3.762
	31.0	1.702	94.5	4.413
	38.2	1.717	95.3	5.073
HMX	8	1.517	79.7	3.526
	16	1.627	85.5	3.475
	32	1.718	90.3	3.508
	64	1.814	95.3	4.644
Tetryl	4	1.434	82.9	3.267
	8	1.535	88.7	3.458
	16	1.623	93.8	4.360
	32	1.687	97.5	5.133
	64	1.732	100.1	6.093
TNT	4	1.353	82.0	5.067
	8	1.446	87.6	5.316
	16	1.549	93.8	5.877
	32	1.623	98.3	6.703
	64	1.561	100.0	8.066
PBXN-7	8	1.711	90.8	5.474
	16	1.792	95.1	5.910
	32	1.850	98.1	6.730
TATB	4	1.519	78.7	7.918
	8	1.645	85.2	8.573
	16	1.762	91.3	9.626
	32	1.840	95.3	11.091
	64	1.887	97.8	13.604

MIL-STD-1751A

Method 1043

**Explosive Shock Sensitivity Test
Expanded Large Scale Gap Test (ELSGT)****1. TYPE OF TEST:** Shock Sensitivity

2. PURPOSE: This test measures the sensitivity of an explosive exposed to an explosive induced shock. This procedure is applicable to explosives that have unconfined critical diameters less than 2.875 inches. If there is any question about whether the test explosive meets this criterion, the critical diameter should be determined before the Expanded Large Scale Gap Test is conducted.

3. BACKGROUND:

3.1 The test is a scaled version of the NOL Large Scale Gap Test (LSGT). It was developed to provide a means for evaluating the shock sensitivity of insensitive explosive compositions which could not be evaluated in the LSGT because of critical diameter constraints.

4. TEST ARRANGEMENT:**4.1 General description:**

4.1.1 The Expanded Large Scale Gap Test (ELSGT) is based on the Large Scale Gap Test (LSGT) described in Test Method 1041. The dimensions of the acceptor system of the ELSGT apparatus are twice the dimensions of the acceptor system of the LSGT apparatus. The dimensions of the donor system of the ELSGT are 1.875 times larger than the dimensions of the donor system of the LSGT system. The witness plate thickness is scaled by a factor of 2.

4.1.2 A standard donor explosive provides an explosive shock pressure of uniform magnitude. The shock is transmitted to the explosive test sample (acceptor) through a barrier of inert material which functions as a well-calibrated acceptor. By varying the thickness of the barrier between the donor and the acceptor, the barrier length required to allow or prevent a detonation of the acceptor is determined. A mild steel (e.g., SAE 1015 - 1026) witness plate is used at the base of the acceptor to provide a clear indication of whether or not the acceptor detonated in the trial. By a series of trials, the thickness of the barrier (gap) material that permits 50% of the acceptor samples to detonate is determined. For a schematic of the test arrangement see figure 1.

4.2 Donor assembly: A Hercules J-2 blasting cap (or equivalent) is used to initiate the donor charge. The donor charge is composed of two stacked 50/50 pentolite pellets, pressed to a density of 1.56 ± 0.01 g/cm³. Each pellet is 3.75 inches in diameter and 1.875 inches thick.

4.3 Gap assembly: The main gap components are cut from a 3.75-inch diameter cast polymethylmethacrylate (PMMA) rod stock having a density of 0.0078 lb/in³ (1.185 g/cm³). The gap size is prepared by stacking various component thicknesses of standard PMMA blocks. Standard thicknesses are 4.0, 2.0, 1.0, 0.5, 0.25, 0.2, 0.1, .050, .025, and .010 inches. As required, circular layers of 0.010-inch thick cellulose acetate are used to adjust the gap to the desired thickness. The use of cellulose acetate as a substitute for PMMA has been determined to have a negligible effect on ELSGT results (see reference (a)).

MIL-STD-1751A

4.4 Acceptor assembly: Acceptors are cast directly into the charge body or machined to a diameter that is small enough to enable them to slide into the cold-drawn, mild-steel tubes. If required, chilling the acceptor to permit a slip fit into the tubes is permissible. The tubes are fabricated from seamless tubing with the ends machined to ± 0.010 inch of the desired length. The tube has an inner and outer diameter of 2.88 inches and 3.75 inches, respectively, while the length is 11.00 inches.

4.5 Witness plate and air space: The dimensions of the cold-rolled, mild-steel witness plate are nominally 12.0 x 12.0 x 0.75 inch. The acceptor is air-spaced 0.125 inch from the witness plate in the test set-up.

5. PROCEDURE:

5.1 Twelve charges are usually required to establish a 50% gap thickness adequately (critical gap). The larger the critical gap, the more sensitive the test material. For an unknown material, the first test is conducted at zero gap. If no detonation occurs, two additional tests are performed at zero gap. If a detonation occurs, the next test is conducted at 50 cards; and thereafter the number of cards is doubled until a negative result, "no-go," is obtained. Subsequent tests are made by dividing in half the gap between the closest "go" and "no-go" until one positive and one negative result, differing by one card, can be obtained.

5.2 At firing, the detonation of the pentolite sends a shock through the gap and into the acceptor. If the transmitted shock initiates a reaction in the test material, the effect of that reaction is shown as damage to the witness plate. The plate is recovered after the shot and then evaluated.

5.3 Interpretation of the witness plate damage is similar to that used in the LSGT method, Test Method 1041. In the LSGT test, a positive result or "go" is recorded when a neat hole is punched in the plate and a broken plate or one with a poor quality hole is considered a "no-go". When a detonation occurred in the ELSGT series used to establish the test method, the plates were broken into 2 to 7 pieces, usually into 4 or 5 unequal pieces (see reference (b)).

6. RESULTS AND DATA:

- 6.1 The following information shall be for this test:
- a. description of the initiation train (detonator, booster (if any) and donor charge)
 - b. material used for steel tube
 - c. gap material used (PMMA, cellulose acetate, or a combination)
 - d. number of trials per test series
 - e. number of test series conducted
 - f. sensitivity of candidate explosive
 - (a) gap thickness in cards or inches for 50% probability of initiation
 - (b) pressure in the gap material at the end of the gap
 - g. sensitivity of reference explosives

6.2 The pressure in the gap material at the end of the gap is obtained from the calibration of the gap thickness for the donor system employed. Reference (c) gives a calibration for the ELSGT with a pentolite donor and PMMA gap.

MIL-STD-1751A

6.3 The pressure at the end of the gap can be converted to a pressure in the acceptor explosive by the use of the shock Hugoniot relationship of the gap material and of the acceptor explosive.

6.4 Results for some common explosives are shown in Table I.

7. SUPPLEMENTARY INFORMATION:

7.1 It is recommended that acceptor charges having the poorest quality, such as those with the highest or lowest densities, the largest repressed section, or the most flaws, be fired first. Thus, the highest quality acceptor charges are available for firing toward the end of the test series where the greatest reproduction is required.

7.2 A comparison of the ELSGT and LSGT (Test Method 1041) test results is discussed in reference (b).

8. NATIONAL REFERENCES:

a. Jaffe, I., Beauregard, R.L., and Amster, A.B., *The Attenuation of Shock in Lucite*, NAVORD 6876, May 1960.

b. Liddiard, T.P. and Price, D., *The Expanded Large-Scale Gap Test*, NSWC TR 86-32, March 1987.

c. Tasker, D.G. and Baker, R.N., *Experimental Calibration of the NSWC Expanded Large Scale Gap Test*, NSWC TR 92-54, January 1992.

Table I. Typical expanded large scale gap test results.

Explosive	Density (g/cm ³)	50% Point (Cards)	50% Point (kbar)
PBXN-109	1.64	405 to 456	12.0 to 14.7
Comp B	1.69	489	10.0
PBXW-126	1.79	164	58.1

MIL-STD-1751A

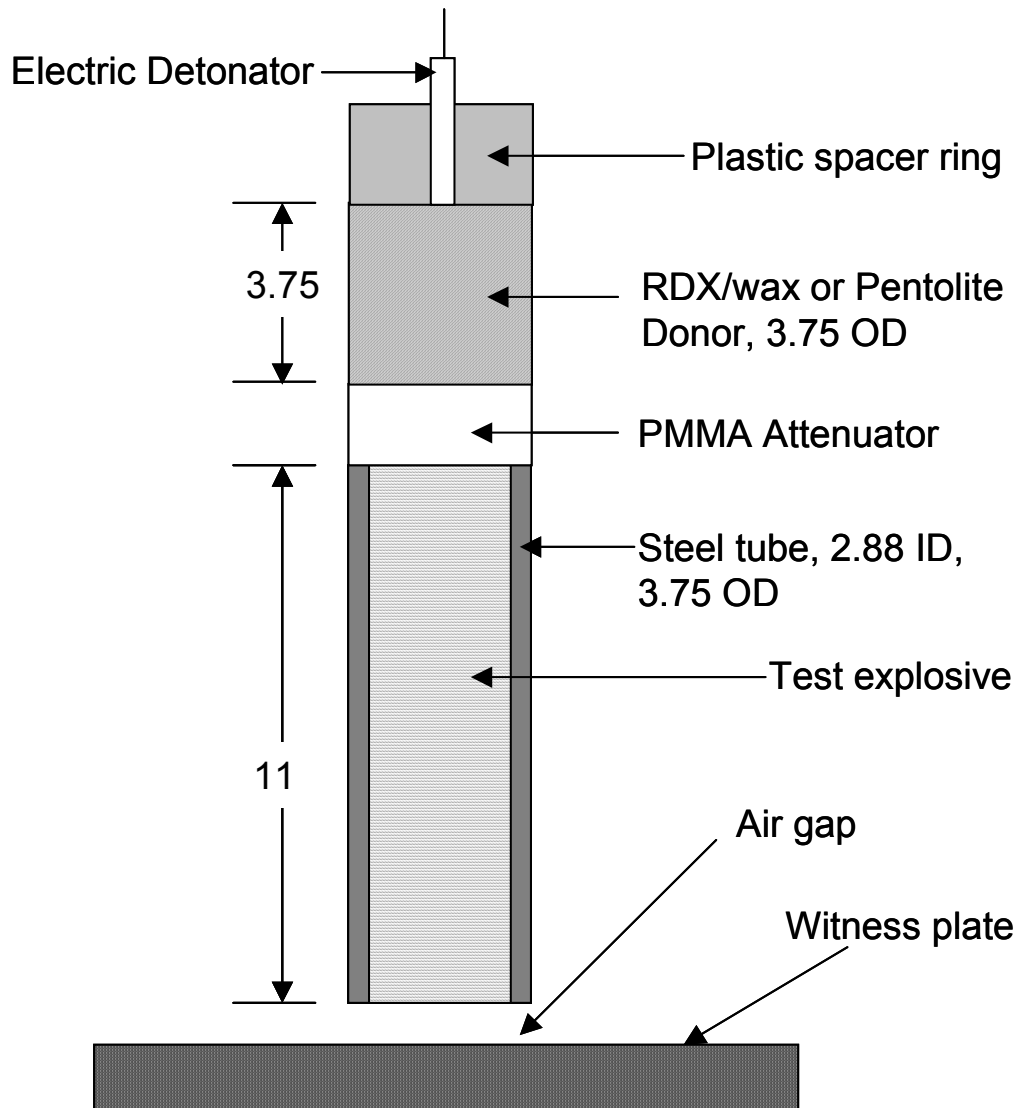

Note: All dimensions are in inches.

Figure 1. Typical Expanded Large Scale Gap Test Set-up

MIL-STD-1751A

Method 1044

Super Large Scale Gap Test

1. TYPE OF TEST: Shock Sensitivity

2. PURPOSE: This test measures the sensitivity to detonation of an explosive exposed to an explosive-induced shock. This procedure is applicable to explosives with large critical diameters ranging up to 7.0 inches.

3. BACKGROUND: None.

4. TEST ARRANGEMENT:

4.1 A schematic of the super gap test is shown in Figure 1. The donor charge in this test is an 8-inch diameter by 8-inch long unconfined Composition B cylinder. The donor charge is initiated with an electric detonator boosted with a 1-inch Composition A-5 pellet. Polymethylmethacrylate (PMMA) cards are used to attenuate the input shock. These cards, stacked to various thicknesses behind the donor charge, are disks of 8 inches in diameter and range from .063 to 2.00 inches thick. The acceptor charge is generally cast into a 0.50 inch thick 1018 mild steel seamless case with an O.D. of 8 inches and a length of 16 inches. Charges should be X-rayed prior to testing to ensure adequate quality of the cast charge. In the test set-up, piezoelectric pins, used to measure detonation velocity, are spaced every 2 inches along the acceptor charge with the first pin being 1/2 inch from the forward explosive metal interface.

4.2 A mild steel (e.g. SAE 1015 - 1026) witness plate, 16" x 16" x 0.75", is used to evaluate whether a detonation has occurred. The evaluation is similar to that used in performing the LSGT and ELSGT tests.

5. PROCEDURE:

5.1 An electric detonator or equivalent exploding bridgewire detonator is used to initiate the Composition A-5/Composition B donor which transmits a shock wave through the PMMA gap and into the acceptor. If the transmitted shock initiates a reaction in the test material, the effect of that reaction is shown as damage to the witness plate. The plate is inspected after each shot with a positive result or "go" defined as a neat hole punched in the plate. An example of a negative result or "no-go" is a broken plate or one with a poor quality hole. Twelve charges are usually required to obtain the mean or 50% point.

5.2 For an unknown material, the first test is generally conducted at zero gap. If no detonation occurs, two additional tests are performed at zero gap. If a detonation occurs, the next test is conducted at 50 cards; and thereafter, the number of cards is doubled until a negative result, "no-go," is obtained. Subsequent tests are made by dividing in half the gap between the closest "go" and "no-go" until one positive and one negative result, differing by one card, can be obtained.

6. RESULTS AND DATA:

MIL-STD-1751A

- 6.1 The following information shall be reported for this test:
- a. description of the ignition train (detonator, booster (if any) and donor charge)
 - b. type of case material used
 - c. criteria for determining go/no-go
 - d. number of trials per test series
 - e. number of test series conducted
 - f. results for candidate explosive
 - i. gap thickness in cards or inches for 50% probability of initiation
 - ii. pressure in the gap material at the end of the gap
 - g. results for reference comparison explosives

6.2 The pressure in the gap material at the end of the gap is obtained from the calibration of the gap thickness for the donor system employed. The calibration data for the Composition A-5/Composition B donor and PMMA gap, which can be used to convert from a gap length in inches to a pressure in kilobars, are given in reference (b).

6.3 The pressure at the end of the gap can be converted to a pressure in the acceptor explosive by the use of the shock Hugoniot relationship of the gap material and of the acceptor explosive.

6.4 Detonation velocity data can also be used to measure whether a steady-state detonation is achieved along the length of the acceptor. In the detonating charge, sufficient data points may be obtained to calculate a detonation velocity. Increasing gap thickness, which corresponds to a weaker input shock, can be shown to result in increased run distance to detonation.

6.5 Results for selected explosives are shown in Table I. Since this is a relatively new test, the database is limited.

Table I. Typical Super Large Scale Gap Test Results.

Explosive	Density (g/cm ³)	50% Point (Inches)	50% Point (kbar)
TNT	1.58	12.0	7.5
PBXN-109	1.64	9.40	13.1
H-6	1.69	9.54	12.5
AFX1100 Mod II	1.529	6.5	31.5
PBXW-126	1.78	4.10	58.1

7. SUPPLEMENTARY INFORMATION: For some materials, the length-to-diameter ratio (L/D) of 2 may be inadequate to resolve the type of reaction of the candidate substance. An L/D of 4 is recommended.

MIL-STD-1751A

Furthermore, the nature of the effect on the witness plate could be ambiguous. Instrumenting the sample with velocity pins is desirable in order to provide for determining whether the shock wave velocity is decaying to a sustained detonation velocity, or it is decaying to the sonic velocity of the sample. With such modifications, when applied to a solid propellant, and using the pass/fail criterion provided in reference (d), the SLSGT may serve to demonstrate that a large rocket motor qualifies for assignment to hazard division 1.3.

8. NATIONAL REFERENCES:

a. Foster, Craig, Parsons and Gunger, "Suppression of Sympathetic Detonation," *Proceedings of the 22nd Explosive Safety Seminar*, Houston, TX, August 1983 (held under the sponsorship of the Department of Defense Explosive Safety Panel).

b. Glenn, J. G., Aubert, S. A., and Gunger, M. E., "Development and Calibration of a Super Large Scale Gap Test," WL-TR-96-7039, August 1996.

c. NATO STANAG 4488, *Explosives, Shock Sensitivity Tests*.

d. TB 700-2, *Department of Defense Explosives Hazard Classification Procedures*. Also known as NAVSEAINST 8020.8B, Air Force TO 11A-1-47, and DLAR 8220.1.

MIL-STD-1751A

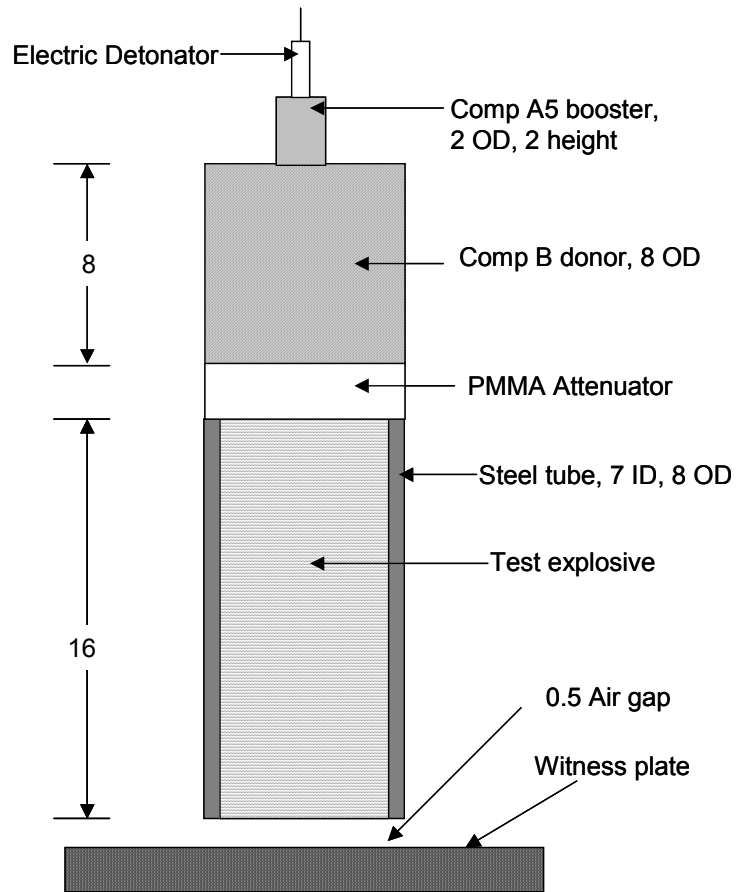

Note: All dimensions are in inches

FIGURE 1. Typical super large scale gap test set-up.

MIL-STD-1751A

Method 1045**Insensitive High Explosive (IHE) Gap Test****1. TYPE OF TEST:** Shock Initiation

2. PURPOSE: This test measures the sensitivity to detonation of an explosive exposed to an explosive-induced shock. This procedure is applicable to explosives with large critical diameters ranging up to 0.75 inch.

3. BACKGROUND: The test was developed to provide a means for measuring the shock sensitivity of insensitive high explosives. The technical objective was to develop a procedure that subjects the test explosive to stresses of 15-80 kbar with a pulse width of several microseconds.

4. TEST ARRANGEMENT: A schematic of the test setup is shown in Figure 1. The test uses a pressed pentolite explosive (density of 1.56 g/cm³) donor system. This consists of two stacked pellets, each 1.0-inch thick and 2.0 inches in diameter. These are the same as the pentolite boosters used in the Large Scale Gap Test described in Test Method 1041. Polymethylmethacrylate (PMMA) spacers are used as the attenuator material between the donor and acceptor charges. Attenuators are machined from 2-inch diameter PMMA stock and are used in standard thicknesses of 0.010, 0.050, 0.100, 0.250, 0.500, 0.750, 1.00, and 1.50 inches. Explosive test samples are cast into a steel cylinder 2 inches long with a 0.5 inch inner diameter and an outer diameter of 0.75 inch. Pressed samples are generally fabricated outside of the test assembly and slid into the acceptor test body. To minimize density gradients, four samples 0.50 inch thick are incorporated into the acceptor body. Unless otherwise specified, powders are sieved and the fraction ranging from 37 to 75 μm is used. Samples, however, may also be pressed directly into the acceptor body. A 0.59 inch thick PMMA spacer is used to separate the base of the acceptor charge and the witness block. The assembly is placed on a steel witness block (3.0 inches in diameter and 1.5 inches thick) which is used to determine whether a detonation has occurred.

5. PROCEDURE:

5.1 In general, a minimum of eight acceptor test bodies are prepared for each explosive test series. The test samples are conditioned at 25°C for 4 hours prior to testing to minimize temperature variation effects on shock sensitivity. "A detonator (E1A, No. 8 blasting cap, or equivalent EBW detonator) is used to initiate the pentolite donors which transmit a shock wave through the PMMA gap and into the acceptor. If the transmitted shock initiates a reaction in the test material, the effect of that reaction is shown as damage to the witness plate and break up of the acceptor confining sleeve. For the first test, no attenuator is used in order to obtain a representative example of a "go". The plate is inspected after each shot with a positive result or "go" defined as a dent exceeding half the depth of the result obtained without an attenuator. Conversely, a negative result or "no-go" is defined as a dent less than half the depth of that obtained with the calibration shot.

5.2 For an unknown material, the first test is generally conducted at zero gap. If no detonation occurs, two additional tests are performed at zero gap. If a detonation occurs, the next test is conducted at 50 cards;

MIL-STD-1751A

and thereafter, the number of cards is doubled until a negative result, "no-go," is obtained. Subsequent tests are made by dividing in half the gap between the closest "go" and "no-go" until one positive and one negative result, differing by one card, can be obtained.

5.3 References (a) and (b) provide a more detailed description of the test procedure and typical test results obtained in the test.

6. RESULTS AND DATA:

- 6.1 The following information shall be reported for this test:
- a. description of the initiation train (detonator, booster (if any) and donor charge)
 - b. method for loading the test hardware (e.g., sample cast directly into steel tube, pressed pellets slipped into tube, molding powder pressed directly into tubes)
 - c. criteria for determining go/no-go
 - d. number of trials per test series
 - e. number of test series conducted
 - f. results for candidate explosive
 - i. gap thickness in cards or inches for 50% probability of initiation
 - ii. pressure in the gap material at the end of the gap
 - g. results for reference explosives

6.2 The pressure in the gap material at the end of the gap is obtained from the calibration of the gap thickness for the donor system employed. The calibration data for a pentolite booster and PMMA gap are given in Table I, which can be used to convert from a gap length in inches to a pressure in kilobars

6.3 The pressure at the end of the gap can be converted to a pressure in the acceptor explosive by the use of the shock Hugoniot relationship of the gap material and of the acceptor explosive.

6.4 Results for some common explosives are shown in Table II.

7. SUPPLEMENTARY INFORMATION: None

8. NATIONAL REFERENCES:

- a. Adolph, Horst, *The Insensitive High Explosives Gap Test*, NSWC TR 86-058, January 15, 1987.
- b. Spivak, Timothy, et al., *Insensitive High Explosives Gap Test Data*, NSWC TR 88-282, September 30, 1988.
- c. Erkman, J.O., Edwards, D.J., Clairmont, A.R., Jr., and Price, D., Calibration of the NOL Large-Scale Gap Test; Hugoniot Data for Polymethyl Methacrylate, NOLTR 73-15, April 1973.

MIL-STD-1751A

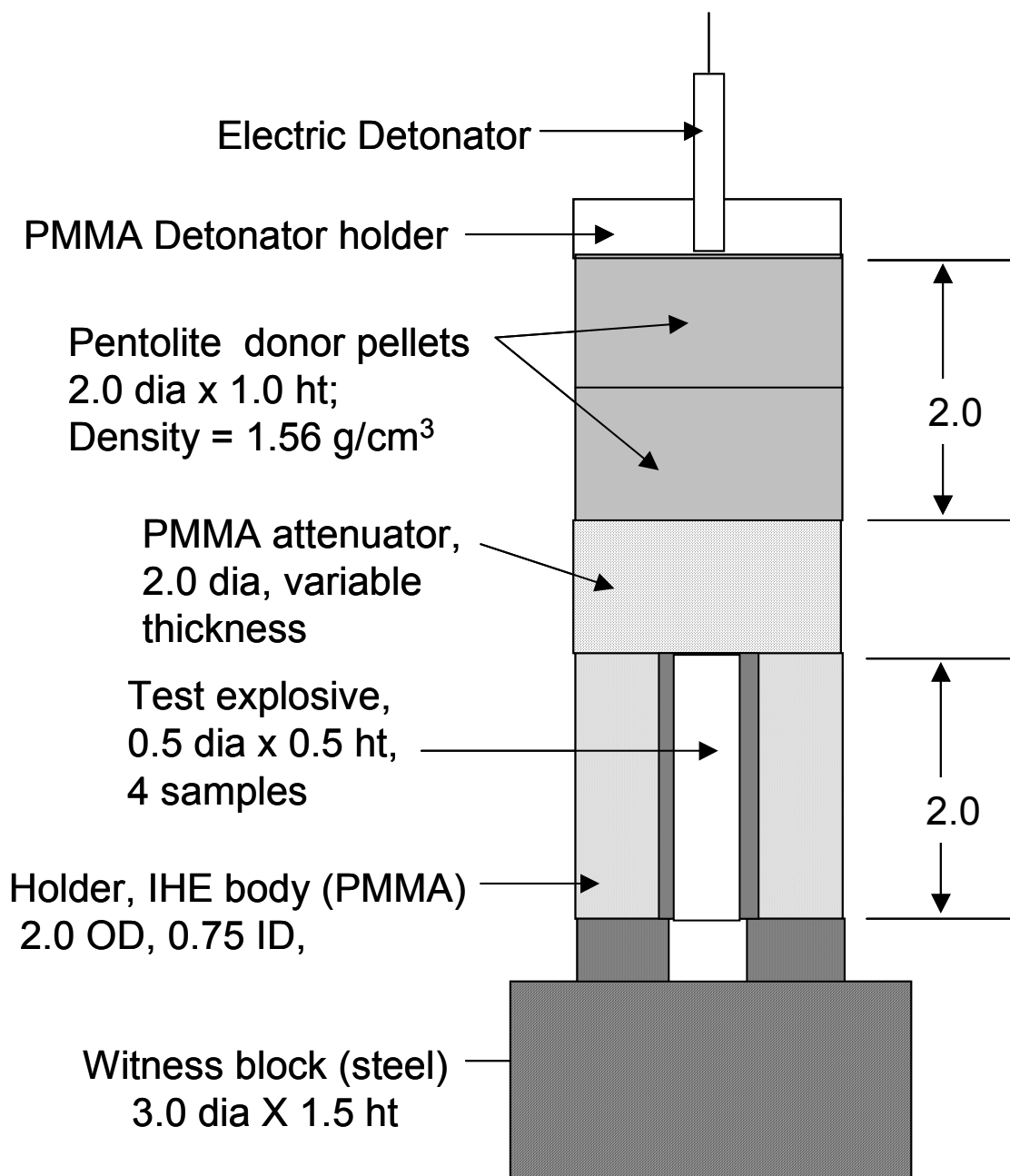

Note: All dimensions are in inches.

FIGURE 1. Insensitive high explosives gap test set-up.

MIL-STD-1751A

TABLE I. NOL large scale gap test calibration data.

Calibration of NOL Large Gap Test for Lot 718 Pentolite

Number of cards in gap is sum of a number in first row and a number in the first column. One card is 0.01 inch; pressure in kilobars.

	0	1	2	3	4	5	6	7	8	9
0	213.1	202.5	192.9	184.2	176.3	169.2	162.7	156.8	151.4	146.5
10	142.0	137.9	134.1	130.6	127.3	124.3	121.6	119.0	116.6	114.4
20	112.3	110.4	108.5	106.8	105.2	103.7	102.2	100.9	99.6	98.3
30	97.2	96.0	95.0	93.9	92.9	92.0	91.1	90.2	89.3	88.5
40	87.7	86.9	86.2	85.4	84.7	84.0	83.3	82.6	82.0	81.3
50	80.7	80.1	79.5	78.9	78.3	77.7	77.1	76.6	76.0	75.5
60	74.9	74.4	73.9	73.3	72.8	72.3	71.8	71.3	70.8	70.3
70	69.8	69.3	68.9	68.4	67.9	67.5	67.0	66.6	66.1	65.7
80	65.2	64.8	64.3	63.9	63.5	63.1	62.6	62.2	61.8	61.4
90	61.0	60.6	60.2	59.8	59.4	59.0	58.6	58.2	57.8	57.4
100	57.1	56.7	56.3	55.9	55.6	55.2	54.9	54.5	54.1	53.8
110	53.4	53.1	52.7	52.4	52.1	51.7	51.4	51.0	50.7	50.4
120	50.1	49.7	49.4	49.1	48.8	48.5	48.2	47.8	47.5	47.2
130	46.9	46.6	46.3	46.0	45.7	45.4	45.2	44.9	44.6	44.3
140	44.0	43.7	43.4	42.8	42.2	41.6	41.0	40.5	39.9	39.4
150	38.9	38.3	37.8	37.3	36.8	36.3	35.8	35.4	34.9	34.4
160	34.0	33.6	33.1	32.7	32.3	31.8	31.4	31.0	30.6	30.2
170	29.9	29.5	29.1	28.7	28.4	28.0	27.7	27.3	27.0	26.7
180	26.3	26.0	25.7	25.4	25.1	24.8	24.5	24.2	23.9	23.6
190	23.3	23.0	22.8	22.5	22.2	22.0	21.7	21.5	21.2	21.0
200	20.7	20.5	20.3	20.1	19.8	19.6	19.4	19.2	19.0	18.8
210	18.6	18.4	18.2	18.1	17.9	17.7	17.5	17.4	17.2	17.0
220	16.9	16.7	16.5	16.4	16.2	16.1	15.9	15.8	15.6	15.5
230	15.3	15.2	15.1	14.9	14.8	14.7	14.5	14.4	14.3	14.1
240	14.0	13.9	13.8	13.7	13.5	13.4	13.3	13.2	13.1	13.0
250	12.9	12.7	12.6	12.5	12.4	12.3	12.2	12.1	12.0	11.9
260	11.8	11.7	11.6	11.5	11.4	11.3	11.3	11.2	11.1	11.0
270	10.9	10.8	10.7	10.6	10.6	10.5	10.4	10.3	10.2	10.2
280	10.1	10.0	9.9	9.8	9.8	9.7	9.6	9.5	9.5	9.4
290	9.3	9.3	9.2	9.1	9.1	9.0	8.9	8.9	8.8	8.7
300	8.7	8.6	8.6	8.5	8.4	8.4	8.3	8.3	8.2	8.1
310	8.1	8.0	8.0	7.9	7.9	7.8	7.8	7.7	7.7	7.6
320	7.6	7.5	7.5	7.4	7.4	7.3	7.3	7.2	7.2	7.1
330	7.1	7.0	7.0	7.0	6.9	6.9	6.8	6.8	6.7	6.7
340	6.7	6.6	6.6	6.6	6.5	6.5	6.4	6.4	6.4	6.3
350	6.3	6.3	6.2	6.2	6.2	6.1	6.1	6.1	6.0	6.0
360	6.0	5.9	5.9	5.9	5.8	5.8	5.8	5.8	5.7	5.7
370	5.7	5.6	5.6	5.6	5.6	5.5	5.5	5.5	5.5	5.4
380	5.4	5.4	5.4	5.3	5.3	5.3	5.3	5.2	5.2	5.2
390	5.2	5.1	5.1	5.1	5.1	5.1	5.0	5.0	5.0	5.0
400	5.0									

Note: Results are nominal for 0 to 39 cards.

MIL-STD-1751A

TABLE II. IHE gap test results.

Explosive	Density (g/cm ³)	% TMD	50% PT (inch)	50% PT (kbar)
HMX	1.81	95.1	2.23	16.4
DATB	1.74	94.6	1.48	39.9
TATB	1.84	94.9	0.85	63.1
TNT (pressed)	1.55	93.8	2.03	20.1
PBXN-7	1.81	95.8	1.93	22.5
PBXN-5	1.75	92.1	2.01	20.5

MIL-STD-1751A

Method 1046**Wedge Test****1. TYPE OF TEST:** Shock Sensitivity

2. PURPOSE: The wedge test is used to determine the shock initiation characteristics of an energetic material.

3. BACKGROUND:

3.1 A planar shock wave is introduced into the explosive to be tested. As the shock progresses through the explosive it generates hot-spots that build up to a detonation. The objective of the wedge test is to determine the run to detonation point at which the detonation wave overtakes the shock wave. This point is characterized by a unique time and distance to detonation for a specific set of input conditions.

3.2 It should be noted that this is just one test for sensitivity and the relative sensitivity rankings between energetic materials may vary for different tests. For example, the NOL Large Scale Gap Test Method gives markedly different sensitivity rankings for the same energetic materials.

4. TEST ARRANGEMENT:

4.1 A streak camera (reference (a)) is used to record the wedge test event. The surface of the wedge is mirrored to reflect light into the camera. A laser is used to align the test fixture and the light sources to the streak camera axis. When either the shock wave or detonation wave reaches the surface, the surface distorts so that light is no longer reflected into the camera. As the detonation wave overtakes the shock wave, the slope of the reflected light trace on the film changes. Thus, the run to detonation point can be determined from the film record.

4.2 The results of a series of wedge tests are usually presented as plots of input pressure versus distance to detonation and time to detonation (Pop-plots). With these plots energetic materials may be compared with regard to relative sensitivity. This is done by assuming that for a given distance to detonation, the energetic material that requires the lower input pressure to achieve this distance is the more sensitive.

4.3 A schematic of the wedge test set-up is shown in Figure 1. A plane wave generator introduces a planar shock wave into the booster charge. The booster charge detonates, introducing a shock wave into the attenuator plates and hence, into the explosive wedge sample. Different booster/attenuator combinations can be used to vary the input pressure into the sample.

4.4 The test arrangement described herein uses plane wave generators which are Los Alamos National Laboratory P-081 lenses, 8 inches in diameter. All of the attenuator systems terminate in Plexiglas. The booster attenuator systems used for this test set-up are listed in Table 1.

MIL-STD-1751A

5. PROCEDURE:

5.1 The wedges are prepared by casting the explosive into the Plexiglas mold shown in Figure 2. The wedges are radiographed for defects to check for density variations. It should be noted that relatively large grains may result in shock and detonation velocity variations.

TABLE 1. Booster attenuator combinations for a wedge test series.

Shot	Wedge height	Booster charge ^{1/}	Driver system
1	1.81 inch (46.0 mm)	Comp B	0.965 inch (24.5 mm) PMMA
2	1.81 inch (46.0 mm)	Comp B	0.839 inch (21.3 mm) 304 S.S. 0.724 inch (18.4 mm) PMMA
3	1.79 inch (45.5 mm)	BARATOL	0.965 inch (24.5 mm) PMMA
4	1.81 inch (46.0 mm)	BARATOL	0.992 inch (25.2 mm) 304 S.S. 0.882 inch (22.4 mm) PMMA
5	1.81 inch (46.0 mm)	Emulsion explosive ^{2/}	1.00 inch (25.4 mm) 304 S.S. 0.882 inch (22.4 mm) PMMA
6	1.79 inch (45.5 mm)	Emulsion explosive ^{2/}	0.996 inch (25.3 mm) PMMA

^{1/} All the booster charges were 1.00 inch thick, and 8 inches in diameter.

^{2/} Nelson Brothers ammonium nitrate/oil emulsion sensitized with microballoons, density = 1.02 g/cm³.

Note: S.S. means stainless steel; PMMA means polymethylmethacrylate.

5.2 A shock is introduced into the wedge sample using the plane wave generator. A streak camera is used to record the wedge test event. The surface of the wedge is mirrored to reflect light into the camera. When either the shock wave or detonation wave reaches the surface, the surface distorts so that the light is no longer reflected in the camera. As the detonation wave overtakes the shock wave the slope of the reflected light trace on the film changes. Thus, the run to detonation point can be determined from the film record. A representative streak camera record is given in Figure 3.

5.3 Further details on procedure are discussed in reference (a).

6. RESULTS AND DATA:

6.1 The following information shall be reported for this test:

- a. description of the initiation train (detonator, plane wave generator, booster material)
- b. dimensions of the plane wave generator
- c. dimensions of the test charge

MIL-STD-1751A

d. data analysis as described below for candidate explosive

6.2 The film records are subsequently digitized on an optical comparator, and the required parameters for reduction of the film data in the order they were analyzed are outlined below.

6.3 FREE SURFACE VELOCITY: To determine the input conditions at the terminal attenuator/explosive sample interface, one needs to measure the free surface velocity ($U_{f.s.}$) of the terminal attenuator by observing the reflection of the needle off the mirrored surface as it moves toward the actual needle. With the defined viewing angle, the magnification, and the camera writing speed, the free surface velocity can be calculated by using the following equation:

$$U_{f.s.} = U_c \tan A/2M \sin B$$

where

- U_c = camera writing speed (mm/ μ s)
- A = angle formed between moving image and real needle
- M = magnification
- B = viewing angle (fixed at 45°)

6.4 FILM DATA CONVERSION

6.4.1 The film records of the wedge traces are typically read in 0.0098 or 0.0197 inch (0.250 or 0.500 mm) increments along the time axis. They are converted to real times using the following equation:

$$t = Y_f/U_c$$

where

- t = real time (μ s)
- Y_f = incremental film time (mm)
- U_c = camera writing speed (mm/ μ s)

6.4.2 The film space data associated with the time readings are then reduced using a similar triangle methods described by Craig (reference (b)). In this method, one only needs to know the actual wedge height and to measure the total film trace width to convert film space to real space. The data are converted using the equation below:

$$X_r = (W_h/W_f)X_f$$

where

- X_r = real space (mm)
- W_h = wedge height (mm)

MIL-STD-1751A

W_f = wedge film trace width (mm)
 X_f = film trace measurements (mm)

6.5 TRANSITION TO DETONATION AND SHOCK VELOCITY:

6.5.1 The transition to detonation is assumed to occur at the region of maximum acceleration along the film trace. These points were read directly from the film records.

6.5.2 To determine the initial shock velocity (U_{so}) in the explosive wedge sample, a plot is made of incremental average velocities (x/t) versus time (t) up to the transition point. Inconsistent data points at the ends of the trajectory are often discarded. The data are then fitted, by a least-squares method, as listed below:

$$X = U_{so}t + 1/2 bt^2$$

where

X = real space (mm)
 t = real time (μs)
 b = acceleration of shock wave ($mm/\mu s^2$)

6.5.3 The derivative evaluated at $t = 0$ is taken as the initial shock velocity (see reference (c)).

6.6 SHOCK HUGONIOT:

6.6.1 To determine the shock Hugoniot of the explosive, only two parameters are needed. These are the shock velocity in the terminal attenuator and the shock velocity in the explosive. To determine the shock velocity in the terminal attenuator, one needs to know its particle velocity and its shock Hugoniot. The particle velocity in the terminal attenuator is defined by assuming that it is one-half of the free surface velocity. The shock Hugoniot for Plexiglas has been well defined by the equation below:

$$U_s = 2.598 + 1.516 U_p \text{ (see reference (d))}$$

6.6.2 Since the shock velocity in the explosive is known from the film records, the particle velocity and initial pressure in the explosive can be calculated using the impedance matching technique which derives the following equations:

$$\begin{aligned}
 P_e &= [Z_a \cdot Z_e / (Z_a + Z_e)] \cdot U_{f.s.} \\
 U_{pe} &= [Z_a / (Z_a + Z_e)] \cdot U_{f.s.}
 \end{aligned}$$

where

P_e = pressure in explosive sample (GPa)
 Z_i = shock impedance = $U_{si} \rho_{oi}$
 U_{si} = shock velocity ($mm/\mu s$)

MIL-STD-1751A

- ρ_{oi} = initial density (g/cm³)
 U_{pe} = particle velocity in explosive (mm/ μ s)
 $U_{f.s.}$ = free surface velocity of attenuator (mm/ μ s)

6.6.3 The impedance matching technique is not accurate as the reflected attenuator Hugoniot and the explosive's Hugoniot are defined by their respective Rayleigh lines. However, the use of other techniques does not substantially increase the accuracy of the shock Hugoniot in this wedge test series.

7. SUPPLEMENTARY INFORMATION:

7.1 The traditional method for plotting the data from the wedge test is known as the Pop-plot. Popolato found that over a range of input pressures, log-log plots of run to detonation, or time to detonation versus pressure, are linear. The equation of the Pop-plot over the linear range, in run to detonation versus pressure form, is then:

$$\log P = A + B \log X^*$$

7.2 In this form, P is in gigapascals, X* is in millimeters, and A and B are determined from a least squares fit in the log-log plane. Similarly, Time to Detonation versus Pressure takes on the same form with different constants.

7.3 Pop-plots provide distance to detonation versus input pressure and time to detonation versus input pressure of a sample explosive. At very low input pressures, the Pop-plot becomes non-linear and pressure approaches a vertical asymptote. This implies that below a certain pressure the run distance can be considered to be infinite and the explosive will not detonate.

7.4 The interpretation of sensitivity behavior of an explosive using these plots is done by observing the behavior of the constants A and B for various explosives. The intercept value A defines the vertical positioning of the Pop-plot; thus it defines the shock region of interest, and B is the slope of the line. Hence, an explosive with a low intercept and shallow slope would be more sensitive at higher pressures and less sensitive at lower pressures compared to a second explosive with higher intercept and steeper slope.

8. NATIONAL REFERENCES:

- a. Davis, W. C. and Craig, B. G., "Smear Camera Technique for Free Surface Velocity Measurement," *Review of Scientific Instruments*, Vol. 32, No. 5, May 1961, p. 579.
- b. Craig, B. G., Personal Communication, May 1987.
- c. Gibbs, T. R. and Popolato, A., eds., *LASL Explosive Property Data*, University of California Press, Berkeley, CA, 1980, pp. 295-296.

MIL-STD-1751A

d. Los Alamos Scientific Laboratory, *Selected Hugoniots*, by Group GMX-6, Report LA-4167MS, Los Alamos, NM, May 1969.

e. Lindfors, Allen J. and Sandstrom, Frederick W., *Wedge Test Results for PBXN-107 Type II*, NWC TM 6792, Naval Weapons Center, China Lake, CA, July 1990.

MIL-STD-1751A

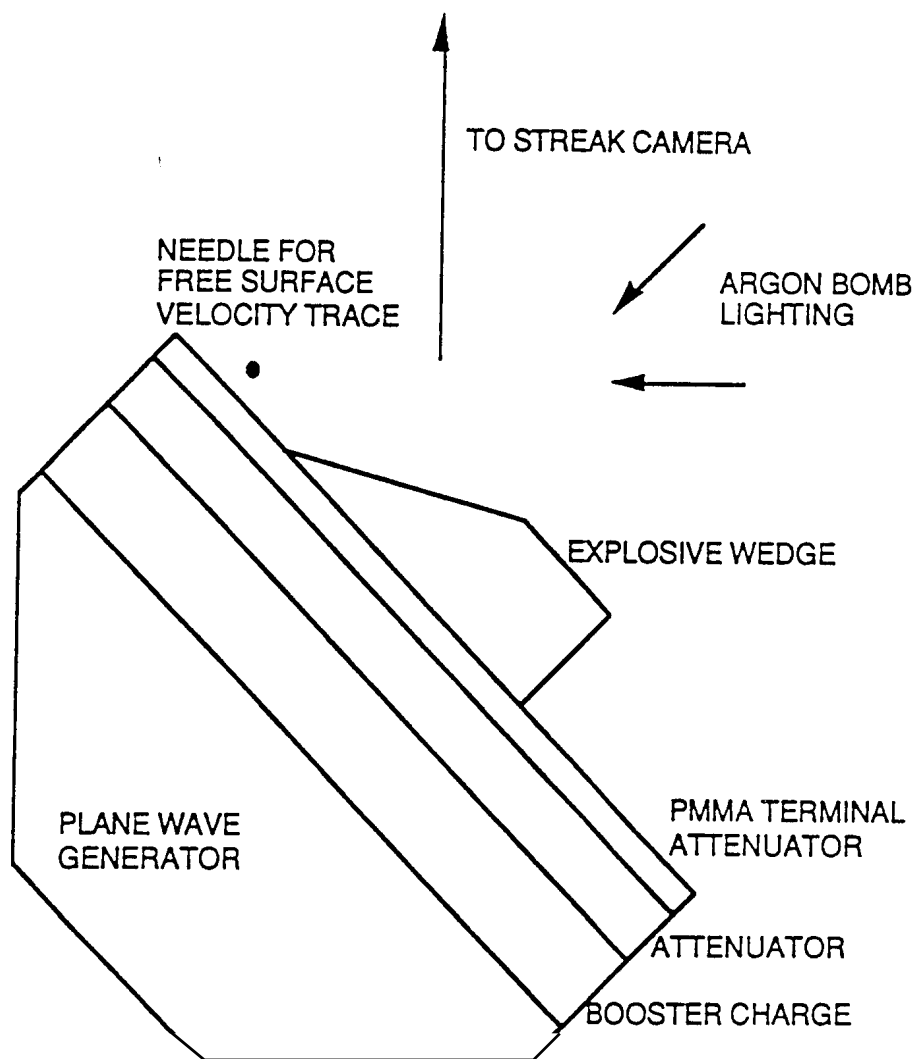
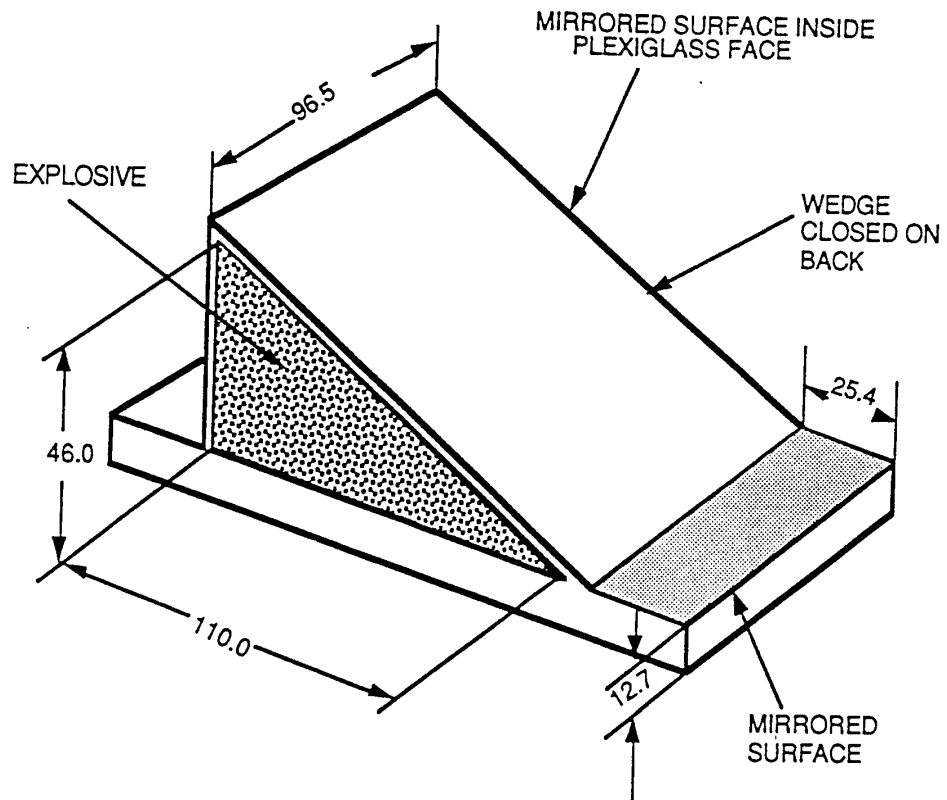

FIGURE 1. Schematic of the wedge test set-up.

MIL-STD-1751A



NOTE: All dimensions are in millimeters.

FIGURE 2. Explosive wedge plexiglas holder.

MIL-STD-1751A

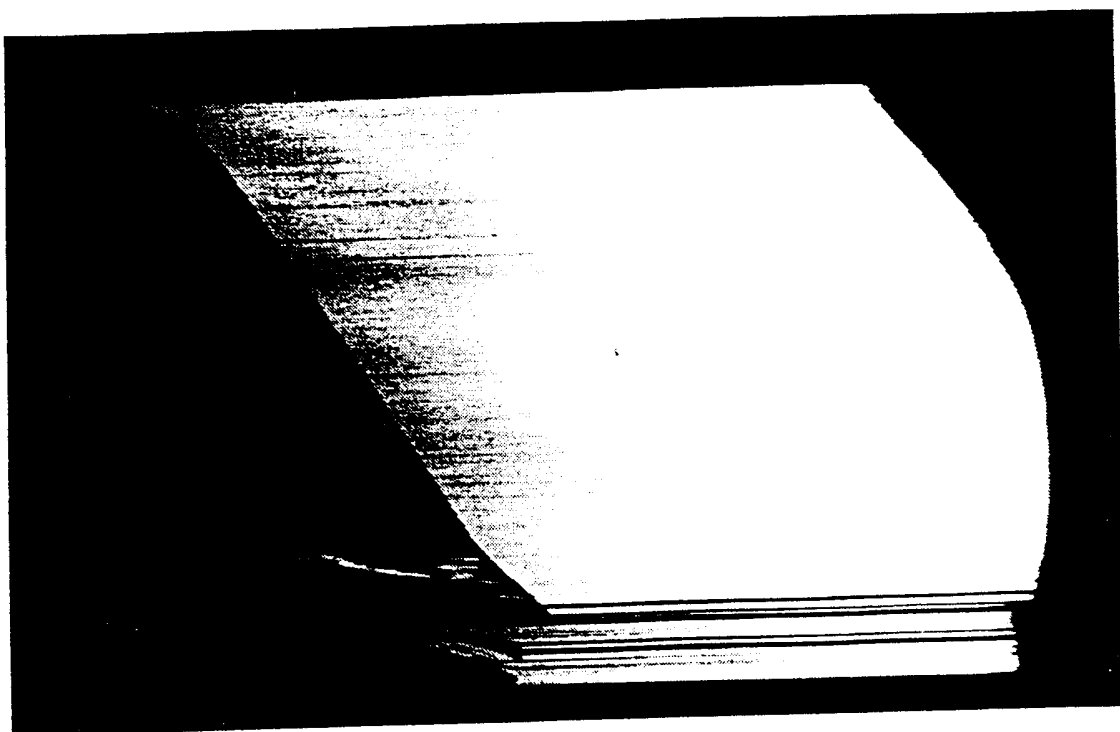

FIGURE 3. Streak camera record of a wedge test of PBXN-107 Type II.

MIL-STD-1751A

Group 1060
Test Methods
Chemical Stability

MIL-STD-1751A

Method 1061**Vacuum Thermal Stability (VTS) Test**

1. TYPE OF TEST: Thermal Stability (Constant Temperature)

2. PURPOSE: This test measures the stability of an explosive at an elevated temperature under vacuum.

3. BACKGROUND:

3.1 In this test, a weighed explosive sample in a measured evacuated volume is heated at a constant elevated temperature for a specified time. The gas pressure in the sample container is measured before, during, and after the test with an attached mercury manometer. The reported result is the volume of gas at standard temperature and pressure produced by the explosive sample. Sample size, container volume, glassware design, and test duration vary among the laboratories conducting the test depending on the purpose for which the test is conducted. Reference (a) provides the NATO-agreed standardized procedures and apparatus.

3.2 Duplicate or triplicate samples, prepared for each test, are heated at 100°C for 48 hours. (Reference (e) requires only 40 hours for propellants.) Staff members at some centers report that samples are heated for 1 hour and then the initial reading is taken. The tests are then run for 48 hours making the total heating time 49 hours.) Sample size is 5.00 ± 0.05 g for booster and main charge explosives and propellants, and 0.200 ± 0.001 g for primary explosives. Propellant samples are ground or rasped to approximately 12 mesh. All samples except solvent propellants should be dried at 65°C for 2 hours; solvent propellants should be dried at 60 to 65°C for 2 to 3 hours.

3.3 An advisory criterion of 2 ml of gas evolved per gram of explosive heated for 48 hours at 100°C applies for main charge and booster explosives. However, main charge explosives which will be subjected to higher temperatures in the application for which they are being qualified, must also be tested at higher temperatures

4. TEST ARRANGEMENT: Figure 1 shows one version of the glass heating container manometer apparatus for VTS measurements. The heating container is connected to the manometer by a ground joint sealed with mercury. This is convenient and can remain leak-free during measurements at 100°C. However, measurements above 200°C on thermally stable explosives require a one-piece version, consisting of glycerin and water (specific gravity 1.05 for 100°C test) or temperature controlled block (oven) such as described in references (c) and (d) and, briefly, in section 7 herein.

5. PROCEDURE:

5.1 Method 1:

5.1.1 The apparatus shown in figure 1 is first calibrated by determining the volume of the heating chamber by filling with mercury from a burette to the level at which the ground glass joint of the capillary tube will make contact with the mercury. (Some test centers report using distilled water in the heating chamber for calibration only). The volume of the capillary tube in ml/mm, symbol C, is determined by averaging the length occupied by a weighed sample of mercury (about 10 g) at three different positions:

MIL-STD-1751A

$$C = \frac{W}{DL}$$

where:

C = volume of capillary in ml/mm

W = weight of mercury in g

D = density of mercury at test temperature in g/ml

L = average length of mercury column in mm

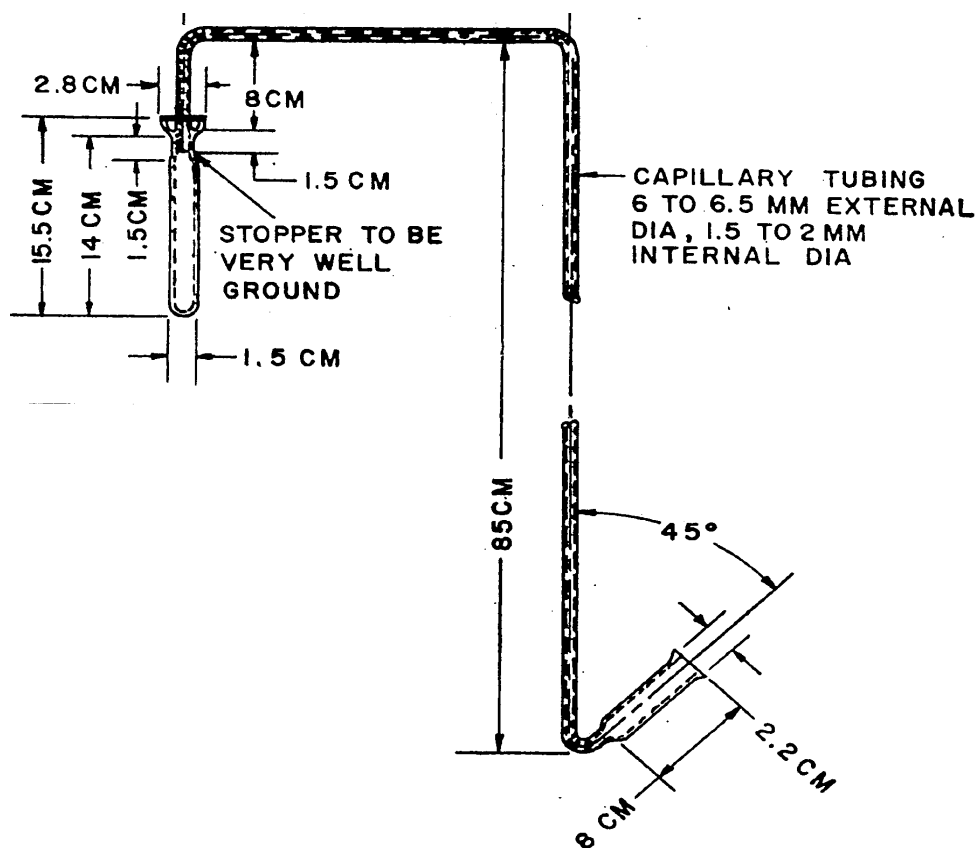

FIGURE 1. Vacuum thermal stability test apparatus.

5.1.2 A dried sample is then added to the heating chamber of the calibrated apparatus. The capillary tube is connected and sealed using a light film of petroleum jelly such as silicone stopcock grease. Press the tube up against the capillary. With the long section of the capillary in a vertical position, 7.0 ml of mercury is added to the lower cup, and the system is evacuated to a pressure of about 0.2 in. (5 mm) of mercury. The vacuum pump is disconnected and the mercury is allowed to enter the capillary. The vertical height of the mercury column minus the height of mercury in the cup is recorded as H_1 . The room temperature is recorded as t_1 , and P_1 is the barometric pressure in mm minus H_1 . The heating chamber is

MIL-STD-1751A

placed in a constant temperature bath or block (oven), maintained at $100.0 \pm 0.5^\circ\text{C}$ for 48 hours (or 49 hours), then it is removed and allowed to cool to room temperature. H is defined as the height of mercury in the capillary minus the cup; P is the barometric pressure minus H; and t is the room temperature. The volume of gas, at standard conditions, evolved by the sample is then calculated with the following formula:

$$V = [A + C (B - H)] \frac{273P}{760 (273 + t)} - [A + C (B_1 - H_1)] \frac{273P_1}{760 (273 + t_1)}$$

where:

- A = the volume of the tube minus the volume of the sample
- B₁ = the total length of the capillary tube minus the measured heights to which 7.0 ml of mercury rises when added to the lower cup 1 inch (about 25 mm)
- B = the total capillary length minus the height of the mercury column at the end of test

The volume of gas per gram (VTS value) is V divided by the weight of the sample in grams.

5.2 Method 2:

5.2.1 The procedure developed for screening explosives at the Naval Surface Warfare Center (NSWC) is somewhat different and more versatile. When the one-piece glass apparatus and a specially designed heating block (oven) are used, measurements have been made at temperatures as high as 300°C ; however, 400°C should present no problem. The main difference is that the heating chamber is smaller (about 10 ml) and sealed to the manometer. The heated volume is measured as the volume of the 1.0 cm outside diameter sample tube plus the capillary out to a reference mark 10.2 cm from the center of the sample tube. This volume is determined by adding water from a burette until the water fills the capillary to the reference mark. The vertical length of the capillary is about 92 cm long with a reference mark 28 cm from the bottom

5.2.2 Although the NSWC apparatus is also used for standard 100°C tests, it was developed for high temperature evaluation of thermally stable explosives.

5.3 **Method 3:** This method is used for thermally stable materials. The most common test, 260°C for 2 hours, is conducted as follows

5.3.1 An accurately weighed, dried 0.2 g sample is transferred to the heating chamber of a calibrated apparatus, which is then placed behind a safety shield and sealed off with a hand-held torch just above the junction with the capillary. The system is evacuated to a pressure of 0.04 inch (0.1 cm) or less with a pump attached to the lower cup. Then 4 ml of mercury is added, atmospheric pressure returned, and the pump is disconnected.

5.3.2 The height of the mercury in the capillary is measured, relative to the reference mark, and the apparatus set aside as a check for leaks. Room temperature and barometric pressure readings are taken. The sample chamber is placed in the 260°C heating block, and the mercury height is measured. This measurement is repeated after 20 minutes and again after an additional 2 hours (140 minutes total). Although this concludes the usual test, samples are often left in the heating block to monitor further decomposition.

MIL-STD-1751A

5.3.3 The first 20 minutes of the test, referred to as the 20-minute surge, is usually excluded from the VTS result as not indicative of the stability of the test material. Eleven minutes are required for the sample to reach the test temperature. The system degasses, and occluded or strongly absorbed solvents are evolved. However, the gas volume of this surge is usually also reported.

5.3.4 The VTS gas evolution volume (corrected to 0°C and 760 mm pressure) is calculated as follows:

$$V = \frac{(273)(Z)(\Delta P)}{(533) (760) (W) (t)}$$

where:

V	=	ml of gas/gram of sample/hour at 260°C
Z	=	volume of hot zone minus volume of sample in ml
ΔP	=	pressure change (change of mercury height) in mm
W	=	sample weight in g
t	=	time in hours

5.4 The VTS test can be run at any temperature appropriate to the explosive application. It can also be used to determine the compatibility of materials in contact in proposed military applications by comparing the gas evolved by an appropriate mixture with that evolved by each of the separate components.

5.5 If excess gassing occurs at 100°C or if 100°C greatly exceeds intended operating requirements, a lower temperature may be used. Commonly used test conditions for various types of materials are given in Annex A of reference (f).

5.6 Reference (a) states that compatibility of materials that decompose too rapidly at 100°C may be tested at 80°C for 240 hours.

6. RESULTS AND DATA:

6.1 The following information shall be reported for this test:

- a. which of the three variations given in Method 1061 was used
- b. period of time for which the sample is heated
- c. temperature at which the test is conducted
- d. the volume of the sample chamber
- e. statement of whether an initial surge volume of gas was excluded from the calculations; if it was, the time period covering the surge and the surge gas volume must also be reported.
- f. number of replicate samples tested.
- g. results for candidate explosive
- h. results for reference explosives

MIL-STD-1751A

6.2 The results shall be reported for each sample tested as the volume at 760 mm of pressure and 0°C of gas evolved per unit mass of the sample. If more than one sample is tested, the average of the replicate determinations shall also be reported.

7. SUPPLEMENTARY INFORMATION:

7.1 The design, construction, and use of a heating block for tests at any temperature between 35 and 400°C is described in references (b) and (c). Significant design features include sample wells in an aluminum block which maintain both the sample chamber and part of the horizontal capillary at controlled temperatures. Separate controls and electric heaters are used so that when sublimation of the sample is a problem, the top and capillary portions of the hot zone can be 5 to 10°C warmer than the rest. The temperature control is designed to shift from low to high power settings (instead of off and on) to reduce temperature fluctuations. The high and low power settings are set to come to equilibrium a few degrees above and below the test temperature, so that during control, the high power is on 50% of the time. The block is arranged symmetrically to contain several samples, but the top is designed so that the insulation is removed only over the position where an apparatus is being inserted or removed.

7.2 Before the sample heating chambers containing explosive samples are sealed, they are lowered into a length of thick-walled steel pipe capped at both ends. The upper cap contains a hole just large enough to accommodate the glass sample tube. Liquid or tacky solid samples must be placed in the bottom of the sample tube with none adhering to upper walls. This is accomplished by weighing them into smaller tubes of known wall volume which are then lowered into the heating container.

7.3 The volume of gas evolved in this test is valid as a measure of the thermal stability of the material being tested only insofar as the gases evolved are the products of the decomposition of the test material. Independent determination that this is the case may be obtained by subjected the evolved gases to analysis by IR spectrometry, GC or GC/MS, or another method that provides information about the identity of the gases.

7.4 There is evidence that, for some explosives, the VTS result depends on the ratio of the sample weight and the volume of the heated chamber. In these cases, the VTS value generally (but not always) decreases as the ratio increases. The effect seems to result from two competing processes: solid state decomposition of the explosive, and slow chemisorption of product gases by the explosive. Therefore, when possible, VTS values should be compared with others obtained under similar conditions. Values of common explosives are given in Table I.

8. NATIONAL REFERENCES:

a. NATO STANAG 4147, *Chemical Compatibility of Ammunition Components with Explosives and Propellants (Non-Nuclear Applications)*.

b. Rosen, A. H. and Simmons, H. T., *Improved Apparatus and Technique for the Measurement of the Vacuum Stability of Explosives at Elevated Temperatures*, NAVORD Report 6629, 12 Mar 1959, Naval Surface Warfare Center, White Oak, Silver Spring, MD 20903-5000.

MIL-STD-1751A

- c. Simmons, H. T., *The Vacuum Thermal Stability Test for Explosives*, NOLTR 70-142, 28 Oct 1970, Naval Surface Warfare Center, White Oak, Silver Spring, MD 20903-5000.
- d. MIL-STD-650, *Explosive: Sampling, Inspection and Testing*, Method 503.1.1.
- e. MIL-STD-286C, *Propellants, Solid: Sampling, Examination and Testing*, Method 403.1.3.
- f. NATO STANAG 4556, *Explosives: Vacuum Stability Test*.

TABLE I. Common explosive values.

Explosive	Temperature (°C)	Test Duration (hrs)	VTS Value (ml/g)
COMP B	100	48	0.30
DATB	200	48	0.11
DATB	230	2	0.21
DIPAM	260	2	2.68
HMX	100	48	0.50
HNX	260	2	0.34
PETN	100	48	0.21
RDX	100	48	0.12
TETRYL	100	48	0.24
TNT	100	48	0.10

MIL-STD-1751A

Method 1062
Chemical Reactivity Test

1. TYPE OF TEST: Thermal Stability (Constant Temperature)

2. PURPOSE: This test evaluates the stability of an explosive at an elevated temperature under vacuum. Both the volume of gas evolved and the composition of these gases are determined.

3. BACKGROUND: The Chemical Reactivity Test (CRT) was developed to provide a means for measuring both the type and volume of gas evolved by a substance or mixture of substances when subjected to elevated temperatures in a fixed volume under vacuum. As such, it provides significantly more information than the vacuum thermal stability test procedure as described in Test Method 1061.

4. TEST ARRANGEMENT:

4.1 Apparatus:

4.1.1 A Hewlett Packard Model 5890 Series II gas chromatograph with a Model 3396 integrator is used to analyze the gas sample. A 20' by 1/8" OD Porapak Q 50-80 mesh molecular sieve is used in the chromatograph. Helium which has been passed through a liquid nitrogen cold trap is used as the carrier gas.

4.1.2 A tank containing heated silicone brake fluid is used to heat the sample under test. Silicone brake fluid is used because it has low volatility and is thermally stable. A temperature control unit which heats and circulates the fluid is attached to the tank. Temperature of the bath is maintained up to 120°C by the control unit to within 1°C of the set point.

4.1.3 Sample holder vessels called "loops" comprise the following stainless steel components: a sample holder with a valve, a diffusion plug (used as a weight), a diffusion upper spacer, a crucible, and a lower spacer. Figure 1 provides a schematic of the CRT sample holder loop assembly.

4.1.4 Vacuum is applied by a vacuum pump system capable of evacuation down to approximately 10 millitorr.

4.2 Materials:

4.2.1 A pressurized gas bottle containing small percentages of N₂, NO, N₂O and CO₂ which are used as calibration gases.

4.2.2 A pressurized gas bottle containing ultra pure (99.999%) helium which is used as a carrier gas.

4.2.3 PBX-9404 is used as the standard reference explosive for the system. PBX-9404 contains 95% TATB and 5% Kel-F as the binder.

MIL-STD-1751A

5. PROCEDURE:**5.1 Sample preparation:**

5.1.1 The CRT is normally run on an explosive composition as a powder unless it is a paste or cast/cure PBX. Consolidated powders (pressed pellets) are generally not attempted. The sample size for the material being tested is 0.250 g. For compatibility tests, both ingredients are weighed to 0.250 g and then blended together. In general, duplicate samples are prepared and run for all materials being tested.

5.1.2 Samples are placed in the loop assembly and the loop is evacuated with vacuum until all outgassing quits. If necessary, the sample may be flushed with helium. The sample loop is then backfilled with one atmosphere of helium.

5.1.3 The sample loop is removed from the vacuum system and placed into the silicon bath holder at 120°C. At the end of the 22-hour heating cycle, the sample loop is removed from the bath and allowed to come to ambient temperature prior to running the gas analysis.

5.2 Sample gas analysis:

5.2.1 The gas chromatograph is calibrated with a calibration gas containing a small percentage of each of the gases being analyzed. In addition, PBX-9404 is routinely run as the standard explosive composition.

5.2.2 The sample loop is connected to the chromatograph and after the chromatograph has stabilized, the sample loop valve is opened and the analysis started. Prior to running a duplicate sample, the air must also be evacuated in the sample loop holder.

6. RESULTS AND DATA:

6.1 Criteria and methods for assessing results: A test result is considered positive, i.e., thermally unstable, if ignition or an explosion occurs. If the CRT gas volumes produced are in excess of 4 cm³/g (approximately 0.8% decomposition), additional tests may be required to determine if the material is thermally unstable. This includes running the test at 100°C and/or increasing the time to 48 hours. If the gas volume produced is less than 4 cm³/g, the material is considered thermally stable. For reference purposes, 1 cm³ of evolved gas/gram of explosive represents about 0.2% decomposition (see reference (a)).

6.2 Compatibility:

6.2.1 If the CRT gas volume of the mixture is equal to or less than the sum of the individual components, there is no evidence of chemical reactivity and the mixture is considered chemically compatible and unreactive.

6.2.2 If the CRT gas volume of the mixture is significantly greater than the sum of the individual components, there is evidence of chemical reactivity and the mixture should be considered incompatible. Generally, total gas volumes of the mixture that are greater than 1.0 cm³/g are moderately reactive and the materials are considered incompatible.

6.3 Typical results: Typical individual gas evolution results for several energetic materials are provided in table I. Units are listed in cm³/0.25 g @ 120°C for 22 hours.

MIL-STD-1751A

7. SUPPLEMENTARY INFORMATION: None.

8. REFERENCES

a. Prokosch, David W., et al., *Chemical Reactivity Test for Thermal Stability*, UCRL-JC-117941, July 1994.

TABLE I. Typical test results.

Explosive Material	N ₂	O ₂	CO	NO	CO ₂	N ₂ O	Total
PETN (powder)	0.046	0	0.038	0.080	0.131	0.014	0.309
PETN (pellet)	0.013	0	0.011	0.028	0.069	0.005	0.126
Comp B (powder)	0.011	0	0	0.024	0.039	0.018	0.092
Comp B (pellet)	0.014	0	0	0.021	0.018	0.020	0.073
LX-14 (powder)	0	0	0	0	0.053	0.006	0.059
LX-14 (pellet)	0	0	0	0.004	0.016	0.006	0.026
LX-17 (powder)	0	0	0	0	0.023	0	0.023
LX-17 (pellet)	0	0	0	0	0.042	0	0.042
PBX-9404 (powder)	0.020	0	0.039	0.244	0.137	0.023	0.463
PBX-9404 (pellet)	0.056	0	0.049	0.171	0.198	0.039	0.513

MIL-STD-1751A

Method 1063**Modified Vacuum Thermal Stability (MVTs) Test**

1. TYPE OF TEST: Thermal Stability (Constant Temperature)

2. PURPOSE: This test provides an indication of the thermal stability of an explosive at an elevated temperature under initial vacuum.

3. BACKGROUND:

3.1 The standard vacuum thermal stability (VTS) test, developed in the early 1900s, measures the chemical stability of an explosive at an elevated temperature under an initial vacuum for a specific time period. Generally, a weighed sample of explosive (5.00 ± 0.05 g) is sealed in an all-glass apparatus designed to measure gas pressure by the mercury manometric method. The system is evacuated and that portion containing the sample is heated at 100°C for 48 hours. The pressure generated by the decomposition gases is measured after the entire system has equilibrated to ambient temperature. The procedure for this standard VTS test is described in Method 1061. Some of the problems associated with this simple system have been described in reference (a). Specifically, these problems include (1) the toxic characteristics of mercury and the fragility of the all-glass system, (2) condensation of water due to the experimental setup, (3) potential inaccuracies associated with corrections and (4) time/labor requirements associated with the test.

3.2 The Modified Vacuum Thermal Stability (MVTs) Test provides a continuous pressure/time record for the specific time period of the test. From this the total volume of gas generated at STP can be calculated. Gas chromatographic analysis of this gas provides the identity of the components and their individual volumes. This allows one to distinguish between those gases associated with thermal decomposition and those resulting from the evolution of adsorbed water/solvent.

3.3 An advisory criterion of 2 cm³ of gas (STP) per gram of sample tested applies for this test. Any explosive which generates more gas than this should be scrutinized carefully before being qualified. Any explosive that is expected to be subjected to temperatures greater than 100°C during the course of its normal use must be tested at those temperatures.

4. TEST ARRANGEMENT: The energetic material is contained in a glass tube that is inserted in a calibrated, stainless steel reaction vessel assembly that is connected to a pressure sensor. The entire system is heated in an oven and the real-time pressure/time data are recorded by a computerized data acquisition system. Total gas volume is computed, reduced to STP and supported by gas chromatographic (GC) analysis. Both dynamic and iso-DSC experiments should be carried out on materials believed to be unstable at the standard test temperature (100°C). This procedure minimizes the possibility of a catastrophic event taking place in the test apparatus.

The apparatus specifications and Operating Instructions for this test method are documented in AFRL/MNME Technical Memorandum 98-60 (reference (b)).

MIL-STD-1751A

4.1 Modified Vacuum Thermal Stability Apparatus Description

4.1.1 Reaction Vessel Assembly: The reaction vessel assembly is composed of a lower reaction vessel subassembly and an upper connector subassembly equipped with two sealed valves. One valve is attached to a pressure sensor and the other to a vacuum pump/helium source. The lower subassembly is attached to the upper subassembly through an O-ring face sealed fitting. The upper subassembly is also connected to the helium and vacuum piping systems with the same type fittings. The reaction vessel volume referred to in a later section is that volume below valves A and B in Figure 1.

4.1.2 Pressure Sensor/Heater Assembly: The pressure sensor/heater assembly is composed of a sensor with a calibrated pressure range of 0 to 100 mm of Hg (full scale) and an upper temperature limit of 200 °C. Each sensor is housed in its own oven which is located external to the main oven where the actual samples are heat treated. The temperature of each pressure sensor is maintained at the same temperature as that programmed for the experiment, almost always 100 °C. During the setup for each experiment, which includes at least two evacuation sequences and one helium refill sequence, the oven temperature may drop to around 50 °C and the pressure sensors to 98°C. After this operation, the sensor temperatures equilibrate to 100°C in about 60 to 70 minutes and the sensor pressure readings to a constant minimum value at full vacuum in 30 to 40 minutes. The overall pressure change, however, is less than 0.05 mm.

4.1.3 Primary MVTS Oven: The primary oven used to heat soak the MVTS samples is a mechanical convection oven, such as the Model 625 oven manufactured by Precision Scientific. The upper temperature limit of the oven is 325 °C. All MVTS experiments are carried out at 100°C unless otherwise specified. The maximum temperature variation over the 48-hour time period of the test is ± 0.1 °C.

5. PROCEDURE:

5.1 Heating Operation

5.1.1 Pre-test Drying/Conditioning: Relatively non-volatile powdered energetic materials, e.g., RDX, HMX, NTO, etc., are dried at temperatures between 40 and 60°C for a minimum of two hours under vacuum. Drying of volatile powders or PBX-type formulations is not mandatory, but may be accomplished in the same temperature range at atmospheric pressure. Reaction vessels and glass tube inserts are dried prior to use. Pre-test exposure of the reaction vessel and inserts to the laboratory atmosphere during sample loading is kept to a minimum.

5.1.2 MVTS Test Procedure: Three samples, either powdered or pieces (PBX formulations), are weighed into glass sample tubes, placed into stainless steel reaction vessels and connected to the three pressure transducers and the vacuum system. These are then evacuated to a pressure less than 10 microns and refilled to atmospheric pressure with helium a minimum of three times. In addition, the power to the oven is in the off position with the oven door open while the pressure transducer heaters are maintained at 100 °C. If samples with volatile components are being tested, the reaction vessels are cooled with an ice and water bath during this procedure. After the final refill the reaction vessels are re-evacuated to a pressure of less than 10 microns and closed off from the vacuum pump. Upon completion of the start-up procedure the oven door is closed and the power returned to the oven (temperature setting is preset). The samples are heated for a total of 2910 minutes (one-half hour to reach 100 °C and 48 hours at temperature). During this 2910-minute

MIL-STD-1751A

time period pressure and temperature data are recorded every 5 minutes by the computerized data acquisition system. At the completion of the test the reaction vessels are cooled to $<-15\text{ }^{\circ}\text{C}$ by use of a salt/ice bath. This latter procedure ensures that all energetic material is removed from the dead volume and condensed into the sealed portion of the reaction vessel.

5.2 Gas Analysis

5.2.1 The gaseous content of the reaction vessels is analyzed by gas chromatography, using a standard gas chromatograph. This test procedure was developed by using a Varian Model 3400 gas chromatograph equipped with a thermal conductivity detector and a stainless steel column, 9 feet long by 0.125 inch in diameter. The column is packed with Porapak Q (100/120 mesh). Helium is used as the carrier gas (flow rate of $40\text{ cm}^3/\text{min}$). The total volume of gas generated during the 48-hour heating period is pushed onto the column by using the carrier gas. The column is maintained at $-98\text{ }^{\circ}\text{C}$ for 8 minutes then heated at $5\text{ }^{\circ}\text{C}/\text{min}$ to $200\text{ }^{\circ}\text{C}$.

5.2.2 The volumes of gases typically observed during vacuum thermal stability testing were calibrated by using the external standard method and a 1 cm^3 sample loop. Standard calibration gases are: H_2 (4.03 %), N_2 (4.98 %), O_2 (5.01 %), CO (4.98 %), CH_4 (4.03 %) and CO_2 (4.99 %) in helium and N_2O (10.00 %) and NO (100.00%). The volume of water generated/desorbed from the energetic sample is calculated by difference ($\text{Volume}_{\text{pressure}} - \text{Volume of Calibrated Gases}_{\text{GC}}$).

6. VOLUME CALCULATION PROCEDURE: The total gas volume, obtained at $100\text{ }^{\circ}\text{C}$ then reduced to standard conditions, is calculated from the total pressure by using equation (1):

$$V_{\text{STP}} = (P_f - P_i)(273.2)(V_{\text{rt}} - V_s)/(760)(T_{\text{oven}} + 273.2) \quad (1)$$

where:

P_f = final pressure (mm)

P_i = initial pressure (mm)

V_{rt} = reaction tube volume (cm^3)

V_s = sample volume (cm^3)

T_{oven} = oven temperature ($^{\circ}\text{C}$).

7 DATA COMPARISON USING RDX CLASS 1 AND HMX CLASS 2

7.1 RDX Class 1. Fifteen samples of RDX Class 1, obtained from Holston Army Ammunition Plant (Lot # HOL86E515-086), were subjected to MVTs testing. Eight tests were carried out with one-gram samples and seven with quarter-gram samples. Nine of the samples were vacuum dried [72 hours at $33\text{ }^{\circ}\text{C}$ (3 each) and at $40\text{ }^{\circ}\text{C}$ (6 each)] and six were used without pretest drying. The results are shown in Table I. The mean gas volume from the one-gram samples was $0.032 \pm 0.003\text{ cm}^3/\text{g}$, where the deviation is of the mean. The mean gas volume from the quarter-gram samples was $0.025 \pm 0.003\text{ cm}^3/\text{g}$, where the deviation is of the mean. The average volume of gas per unit mass of RDX (no class specified) reported by Holston AAP (reference (d)) is $0.08\text{ cm}^3/\text{g}$. Holston AAP uses the standard vacuum thermal stability test method (mercury

MIL-STD-1751A

manometric). Additional vacuum thermal stability data from four classes (1,3,4 and 5) of RDX are shown in Table III (reference (d)).

7.2 HMX Class 2. Nine samples of HMX Class 2, obtained from Holston Army Ammunition Plant, were subjected to MVTS testing. Six of the samples were from Lot # HOL86E515-086. All of the samples were subjected to pre-test drying under vacuum. The test results are shown in Table II. The mean gas volume was 0.044 ± 0.004 cm³/g, where the deviation is of the mean. The average volume of gas per unit mass of HMX (Class 1) reported by Holston AAP (reference (c)) is 0.06 cm³/g. Holston AAP uses the standard vacuum thermal stability test method (mercury manometric).

8. REFERENCES:

a. M. Benchabane, The Discontinuous Vacuum Stability Test (DVST), J. Energetic Materials, **11** (2), 89-100, June 1993.

b. McKenney, Robert L., Jr., AFRL/MNME Technical Memorandum 98-60, Modified Vacuum Thermal Stability Apparatus, 18 December 1998.

c. Personal communication from Mr. Charles Smith of Holston Defense Corporation, Kingsport TN dated 11/796.

d. D.T. Knutson and K.E. Newman, Processing and Vulnerability Evaluation of Batch Manufactured RDX, IHTR 1802, Indian Head Division, Naval Surface Warfare Center, Indian Head, MD, 24 March 1995.

MIL-STD-1751A

Table I. Modified Vacuum Thermal Stability Data for RDX Class 1 (Holston AAP Lot # HOL86E515-086).

Expt #	Sample Weight (g)	Gas ¹ Volume _(GC) (cm ³ /g)	Gas ² Volume _(Pressure) (cm ³ /g)	Water ³ Volume (cm ³ /g)
656 ⁴	1.0020	0.026	0.35	0.33
657 ⁴	1.0033	0.032	0.40	0.37
668 ⁵	1.0005	0.030	0.12	0.09
669 ⁵	1.0003	0.023	0.12	0.10
670 ⁵	0.9999	0.027	0.13	0.10
650 ⁶	1.0024	0.025	0.39	0.37
653 ⁶	1.0032	0.044	0.79	0.75
654 ⁶	1.0034	<u>0.046</u>	0.88	0.83
	Average:	0.032 s _m = ± 0.003		
658 ⁴	0.2510	0.030	0.28	0.25
665 ⁵	0.2508	0.017	0.07	0.05
666 ⁵	0.2501	0.016	0.07	0.05
667 ⁵	0.2502	0.020	0.07	0.05
651 ⁶	0.2410	0.028	0.33	0.30
652 ⁶	0.2510	0.025	0.27	0.25
655 ⁶	0.2502	<u>0.038</u>	0.63	0.59
	Average:	0.025 s _m = ± 0.003		

1. Gases detected and quantified by gas chromatography were N₂, O₂, CO₂ and N₂O. O₂ is assumed to have resulted from trapped air that was evolved during the 48-hour test. The gas volume shown in column three above is not corrected for the assumed presence of air. All H₂O is assumed to have been desorbed from open, microporosity during the test and is also not included in column three.

2. This volume (corrected to STP) is computed from the gas pressure measured at 100 °C. It includes all volatiles.

3. H₂O volume is calculated by subtracting the total gas volume in column 3 from that in column 4.

4. Dried at 33 °C.

5. Dried at 40 °C.

6. Not dried.

MIL-STD-1751A

Table II. Modified Vacuum Thermal Stability Data for HMX.

Expt #	Sample Weight (g)	Gas ¹ Volume _(GC) (cm ³ /g)	Gas ² Volume _(Pressure) (cm ³ /g)	Water ³ Volume (cm ³ /g)		
528 ⁴	1.0020	0.059	0.45	0.39		
529 ⁴	1.0033	0.043	0.62	0.58		
530 ⁴	1.0005	0.052	0.65	0.60		
659 ^{5,6}	1.0003	0.047	0.72	0.67		
660 ^{5,6}	0.9999	0.054	0.76	0.71		
661 ^{5,6}	1.0024	0.057	0.74	0.68		
671 ^{6,7}	1.0032	0.024	0.19	0.17		
672 ^{6,7}	1.0034	0.032	0.20	0.17		
673 ^{6,7}	1.0010	<u>0.028</u>	0.19	0	1	6
Average:		0.044	$s_m = \pm 0.004$			

1. Gases detected and quantified by gas chromatography were N₂, O₂, CO₂ and N₂O. O₂ is assumed to have resulted from trapped air that was evolved during the 48-hour test. The gas volume shown in column three above is not corrected for the assumed presence of air. All H₂O is assumed to have been desorbed from open, microporosity during the test and is also not included in column three.

2. This volume (corrected to STP) is computed from the gas pressure measured at 100 °C. It includes all volatiles.

3. H₂O volume is calculated by subtracting the total gas volume in column 3 from that in column 4.

4. Dried at 57 °C for 96 hours under vacuum.

5. Dried at 33 °C for 72 hours under vacuum.

6. Class 2 (Holston AAP Lot # HOL77G240-002).

7. Dried at 40 °C for 144 hours under vacuum.

MIL-STD-1751A

Table III. RDX Vacuum Thermal Stability Test Data (Reference 3)

<u>RDX¹</u> <u>Class</u>	<u>RDX Process/Type²</u>	<u>Volume³</u> <u>(cm³/g)</u>
1	Continuous	0.33
	Batch	0.39
3	Continuous	0.32
	Batch	0.36
4	Continuous	0.19
	Batch	0.27
5	Continuous	0.18
	Batch	0.11
3	Arbitrary control sample	0.18

1. RDX obtained from Holston Army Ammunition Plant.
2. Refers to continuous and batch processed RDX.
3. 100 °C for 48 hours.

MIL-STD-1751A

Group 1070
Test Methods
Self-Heating

MIL-STD-1751A

**Method 1071
Differential Thermal Analysis (DTA)**

1. TYPE OF TEST: Thermal stability (variable temperature)

2. PURPOSE: The test is used to evaluate the behavior of energetic materials when subjected to a temperature rise. Characteristics displayed on thermograms can be used to monitor samples in comparison to controls and to examine if changes have occurred in a sample which may affect stability. Results provide onset temperature and peak maxima of any endothermic or exothermic events.

3. BACKGROUND: DTA records the difference in temperature between a substance and a thermally inert reference material when both are subjected to the same thermal conditions. Sample and reference holders are each fitted with their own temperature sensing device, usually thermocouples connected in opposition. Sample and reference holders are fitted in a heat sink, i.e., a metal block, which is surrounded by a heat source which can be programmed to raise the temperature of both the sample and reference material at a predetermined rate.

3.1 Principle of operation: If, upon heating, there are no transitions or reactions occurring within the test sample, the difference in temperature between the sample and reference (ΔT) is effectively zero. Temperature differences between the sample and reference are brought about by either endothermic or exothermic transitions or reactions within the sample pan. During "endothermic transitions," the sample undergoes "isothermal arrests" whereby its temperature remains relatively constant during the transition although there is an input of heat into the sample during this transition. The reference temperature continues to rise at the predetermined rate over this period, hence a differential temperature exists between sample and reference with the sample lagging the reference.

3.2 Conversely, during exothermic reactions, the heat evolved from the sample gives rise to a temperature difference between the sample and reference where the ΔT signal has the opposite polarity. These changes lead to a departure from the $\Delta T = 0$ baseline during transitions resulting in a peak in the output signal. When the transition is over, the sample "catches up" with the reference and the signal returns to the steady state as was observed before the transition. A gradual return to the baseline is observed due to the relatively low thermal conductivity of the sample crucible material. When the technique is used in conjunction with a photodetector system, the ignition temperature may also be recorded.

4. TEST ARRANGEMENT:

4.1 Apparatus:

4.1.1 Some Differential Thermal Analyzers are capable of heating rates up to $50^{\circ}\text{C}/\text{min}$, although a typical heating rate for this experiment is $10^{\circ}\text{C}/\text{min}$. The analyzer used in this method should automatically record the differential temperature between the sample and reference materials. It should

MIL-STD-1751A

have an upper temperature capability of at least 500°C.

4.1.2 Sample crucibles are required which should be manufactured from materials which are inert to the material under test. They should be large enough to be able to accommodate up to 30 mg of sample and be robust enough to withstand the mechanical forces and high temperatures encountered during ignition reactions. Materials such as alumina and platinum are generally suitable. Alumina is the preferred material since the crucibles are readily cleaned by boiling in concentrated acids.

4.1.3 Purge gas supply and an associated flow controller.

4.1.4 Inert reference material which is not thermally active over the temperature range to be used. For most applications, alumina has been found to be suitable.

4.1.5 Balance capable of measuring to an accuracy of ± 0.01 mg.

4.1.6 Additional apparatus required for temperature of ignition studies

- a. Dead weight press (1 kg) with a ram diameter slightly smaller than the internal diameter of the sample crucible
- b. Photodetector and associated signal amplification circuitry

4.2 Calibration: Since a DTA instrument is used only semiquantatively for measurement of endothermic and exothermic transitions, accurate calibration of the heat of transition reaction is not generally necessary. However, if heat of transition/reaction is to be measured, calibration can be achieved through the measurement of the heat of fusion of standard reference materials.

4.2.1 Because of the robustness of construction and the relatively low thermal conductivity of the sample crucible materials, temperature calibration to within $\pm 2\%$ is considered acceptable. Generally, calibration shall be performed at two points using standard reference materials with melting point onsets close to the limits of the temperature range of interest. Calibration should be carried out using the same type of crucible, heating rate, purge gas, and purge gas flow rates that will be used for test measurements.

4.2.2 Typical standard reference materials used for temperature and enthalpy calibration are shown in the table below:

Material	Melting point (°C)	Heat of fusion (J/g)
Indium	156.6	28.42
Zinc	419.5	108.0
Aluminum	660.2	397.0

MIL-STD-1751A

5. PROCEDURE:

5.1 Sample preparation: Samples should be representative of the material in the final form anticipated for service use. Cast cure materials shall be fully cured. Powders may be consolidated to a density similar to that proposed for a final configuration if deemed necessary to achieve good contact between the sample and the crucible.

5.2 The energetic material being evaluated should be weighed accurately and placed in one sample crucible while the reference material should be placed in another. These should then be loaded into the instrument. Reference (a) provides recommended sample sizes for different types of explosive materials. There should be intimate contact between the sample or reference material and the sensors.

5.3 The sample chamber should be purged with an appropriate gas and the flow rate recorded. If, however, temperature of ignition studies are being performed, the experiment is generally conducted in a static air environment.

5.4 The sample is then heated at the chosen heating rate over the temperature range of interest. Reference (a) provides recommended heating rates for different types of explosive materials. A thermogram is produced showing heat flow versus temperature. The evaluation of the curve associated with the exothermic event may require a different approach if the curve has multiple peaks or peaks with complex structure. The temperature associated with all peaks should be reported.

6. RESULTS AND DATA:

- 6.1 The following information shall be reported for this test:
- a. instrument
 - b. heating
 - c. purge gas and flow rate
 - d. sample
 - e. method of loading into sample
 - f. type of sample pan used (material of construction; open or closed; crimped or uncrimped; lid bulged up or down; etc)
 - g. atmosphere in which pan was prepared and sealed
 - h. thermogram
 - i. onset temperatures, peak temperatures, and temperature at which the trace returns to the baseline for all endotherms and exotherms.

7. SUPPLEMENTARY INFORMATION: None.

MIL-STD-1751A

8. REFERENCES:

- a. NATO STANAG 4515, *Thermal Characterization of Explosives*.
- b. ASTM E537-86, *Standard Test Method for Assessing the Thermal Stability of Chemicals by Methods of Differential Thermal Analysis*, Philadelphia: American Society for Testing and Materials, 1986.

MIL-STD-1751A

Method 1072
Differential Scanning Calorimetry (DSC)

1. TYPE OF TEST: Thermal stability (variable temperature)

2. PURPOSE: The test is used to evaluate the behavior of energetic materials when subjected to a temperature rise. Characteristics displayed on thermograms can be used to monitor samples in comparison to controls and to examine if changes have occurred in a sample which may affect stability. Results provide onset temperature and peak maxima of any endothermic or exothermic events.

3. BACKGROUND: This technique measures the heat flow to/from a sample as it undergoes transitions in a thermally controlled environment. Two types of instrumentation are generally used for measuring heat flow - power compensation DSC and heat flux DSC.

3.1 Power compensation DSC consists of individual sample reference holders, identical in size and material of construction, each fitted with its own heater and platinum resistance thermometer. In normal operation, the sample pan contains the explosive while the reference pan is either left empty or is filled with an inert reference material. The system is operated by two electronic control loops. One is for the average temperature control so that the temperature of sample and reference can be increased at a predetermined rate. The second loop ensures that if a temperature differential develops between reference and sample (due to exothermic or endothermic reaction in the sample), the power input is adjusted to remove this difference. Thus the temperature of sample and reference is kept the same by the continuous and automatic adjustment of the heater power for either the sample or the reference element depending on whether the sample undergoes exothermic or endothermic changes. Therefore, a signal is produced which is directly proportional to the difference between the heat input to the sample and that to the reference. The area beneath the curve is a direct measure of the heat involved in bringing about the transition, i.e., heat flow to/from the sample (dH/dt). This is usually measured in milliwatts. Figure 1 provides a schematic diagram of a power compensation DSC.

3.2 Heat flux DSC instruments operate on the DTA principle (see Test Method 1071) as shown in Figure 2. Mathematical manipulation of the measured DTA signal is used to obtain values of heat flow to/from the sample to bring about the transition. The thermal analog of Ohm's law is used:

$$dH/dt = \Delta T/R_{th}$$

where dH/dt is the heat flow

ΔT is the differential temperature

R_{th} is the thermal resistance to heat flow between the sample pan and holder

MIL-STD-1751A

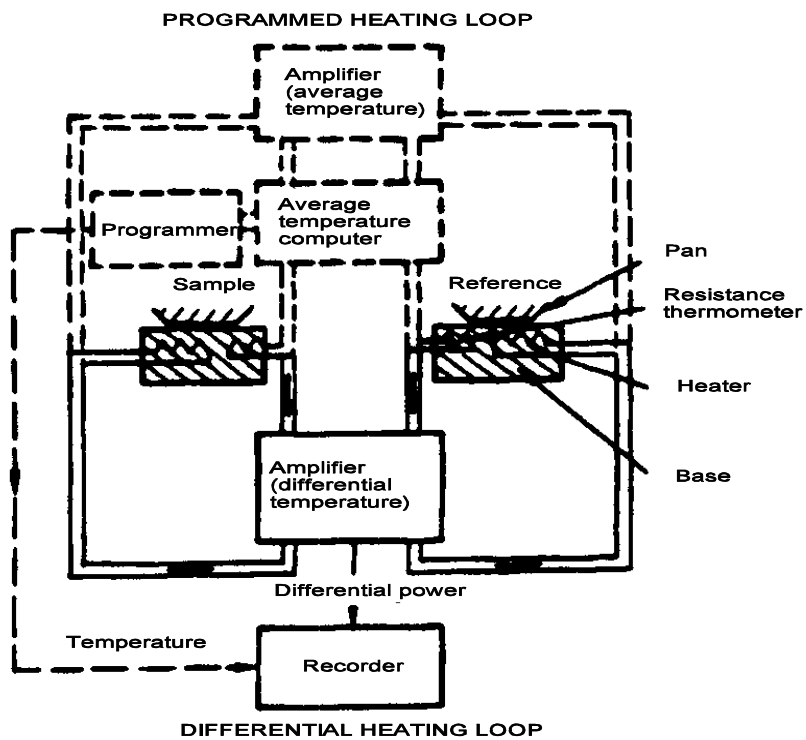

FIGURE 1. Power compensation DSC schematic diagram.

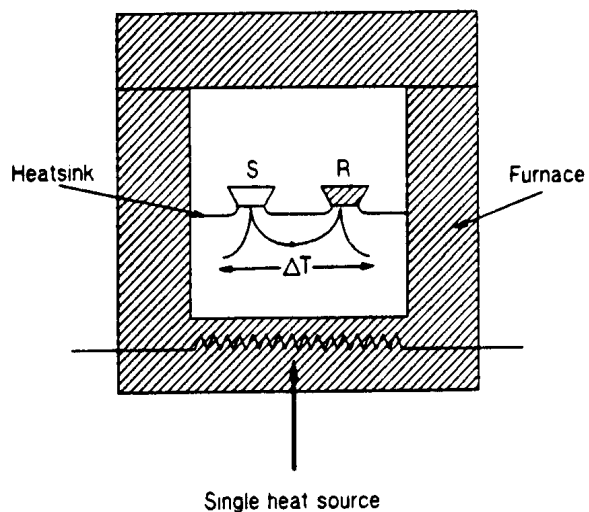

FIGURE 2. Heat flow DSC schematic diagram.

MIL-STD-1751A

3.2.1 The heat flow to/from the sample given by the difference in heat flows to the reference and sample holders.

$$dH/dt = dQ_S/dt - dQ_R/dt$$

where dQ_S = heat flow to sample
 dQ_R = heat flow to reference

3.2.2 Applying the "thermal" Ohm's law:

$$dH/dt = -(T_S - T_R)/R_{th}$$

where T_S and T_R are the temperatures of the sample and reference, respectively

The temperature difference given by the output from the two thermocouples connected in opposition is given by:

$$\Delta T = \Delta U/S$$

where ΔU is the thermocouple potential (μV)
 S is the thermocouple sensitivity ($\mu V/K$)

It follows that:

$$dH/dt = \Delta U/R_{th}S$$

dH/dt has a -ve value for exothermic reactions and a +ve value for endothermic reactions.

3.2.3 Both R_{th} and S are functions of temperature and can be combined as the calorimetric sensitivity. This is determined by calibration using the known heat of fusion of the reference material and gives a value of the measuring cell sensitivity in $\mu V/mW$. This term is also referred to as the cell constant.

4. TEST ARRANGEMENT:

4.1 Apparatus:

4.1.1 A Differential Scanning Calorimeter is required which is capable of providing heating rates up to $20^\circ C/minute$ with the capability to automatically record the differential heat flow between the sample and reference materials with the required precision and accuracy. It should have an upper temperature capability of at least $500^\circ C$.

4.1.2 Sample crucibles must be manufactured from material that is inert to the material under test and has high thermal conductivity. Aluminum is the most typically used material.

MIL-STD-1751A

4.1.3 A purge gas supply with an associated flow controller.

4.1.4 If a reference material is used, it must be thermally inert over the temperature range to be used. For many applications, alumina is a suitable inert reference material.

4.1.5 Crucible sealing press for sample preparation.

5. PROCEDURE:

5.1 Sample preparation: Samples should be representative of the material in the final form anticipated for service use. Cast cure materials shall be fully cured. Powders should be consolidated to a density similar to that proposed for a final configuration.

5.2 Calibration should be performed by measurements of the heats of fusion and melting points of standard reference materials. The instrument should be calibrated using the same type of sample crucible, heating rate, purge gas, and flow rates as will be used for the test instruments. Typical standard reference materials are shown in the table below:

Material	Melting point (°C)	Heat of fusion (J/g)
Indium	156.6	28.42
Lead	327.5	23.10
Zinc	419.5	108.0

Melting point onsets within $\pm 0.5^\circ\text{C}$ and heats of fusion within $\pm 2\%$ are generally considered acceptable.

5.3 Samples should be accurately weighed and placed in the sample and reference material crucibles. The sample chamber should be purged with the inert gas at the flow rate recommended by the DSC apparatus manufacturer.

5.4 The sample should be heated at the recommended rate ($10^\circ\text{C}/\text{minute}$, maximum) over the temperature range of interest and a recording of the thermogram should be produced.

6. RESULTS AND DATA:

- 6.1 The following information shall be reported for this test:
- Instrument used
 - Heating rate
 - Purge gas and flow rate
 - Sample mass
 - Type of sample pan used (material of construction; open or closed; crimped or uncrimped; lid bulged up or down; etc)
 - Atmosphere in which pan was prepared and sealed
 - Thermogram

MIL-STD-1751A

h. Onset temperatures, peak temperatures, and temperature at which the trace returns to the baseline for all endotherms and exotherms.

7. SUPPLEMENTARY INFORMATION: None.

8. NATIONAL REFERENCES:

- a. NATO STANAG 4515, *Thermal Characterization of Explosives*.
- b. ASTM E537-86, "Standard Test Method for Assessing the Thermal Stability of Chemicals by Methods of Differential Thermal Analysis," Philadelphia: American Society for Testing and Materials, 1986.

MIL-STD-1751A

METHOD 1073

Thermogravimetric Analysis (TGA)

1. TYPE OF TEST: Thermal Stability

2. PURPOSE: This test is used primarily to determine the weight loss (or gain) associated with an energetic material when it is subjected to isothermal conditions or increasing temperature in a flowing inert or oxidizing atmosphere. Kinetics parameters can be obtained from TGA experiments.

3. BACKGROUND: Thermogravimetric analysis measures the change in weight of a test sample as a function of temperature and time. The technique can be useful in distinguishing between phase changes (solid-state, melting) and weight changes resulting from chemical reactions (thermal degradation, metal oxidation, etc.). Data acquired from this technique can be more useful if used in conjunction with other techniques, such as DTA, DSC, FTIR., i.e., TGA/DSC on the same sample.

4. TEST ARRANGEMENT:

4.1. Apparatus:

a. Thermogravimetric analyzer capable of heating rates of up to 20°C/minute, with a weighing accuracy of ± 0.01 mg, and automatic recording capability of sample weight loss/gain as a function of temperature.

b. Sample crucibles manufactured from material that is chemically inert to the material under test. Typical materials of construction are aluminum and platinum.

c. Purge gas supply (usually nitrogen, argon or helium) and an associated flow controller. Argon is recommended, since nitrogen can react with some metal surfaces.

5. PROCEDURE:

5.1. Sample preparation: Samples should be representative of the material in the final form anticipated for service use. Cast-cured materials shall be fully cured. Powders can be used as such or consolidated to a density similar to that proposed for a final configuration.

5.2. Temperature calibration shall be performed by a procedure described by the manufacturer.

5.3. The sample chamber is purged with an inert gas at all times. The flow rate can be adjusted for periods when the instrument is not in use.

5.4. The test sample is placed in the sample crucible and the weight recorded.

5.5. The heating rate (dynamic experiment) shall be determined by the objective of the experiment. Some energetic materials are volatile and will volatilize from the sample pan during this test, sometimes prior to reaching the melting temperature

MIL-STD-1751A

6. RESULTS AND DATA:

6.1. The following information shall be reported for this test:

- a. instrument used to conduct the test
- b. calibration standards used
- c. gas used for purging
- d. gas flow rate
- e. heating
- f. material of construction of crucible
- g. weight losses and gains between start and end of reactions, as percentages
- h. physical processes associated with weight loss steps, if possible, e.g.,
 - i. loss of volatile matter
 - ii. decomposition
- i. derivative weight loss trace

6.2. Figure 1 provides a typical format for reporting of the data from a TGA.

6.3. The derivative weight loss trace is a measure of the weight loss as a function of time/temperature and is characteristic of the material or composition. It generally consists of a series of peaks, each corresponding to a weight loss or gain step. It can be used as a thermogravimetric fingerprint for characterization purposes.

7. SUPPLEMENTARY INFORMATION: None.

8. REFERENCES:

- a. NATO STANAG 4515, *Thermal Characterization of Explosives*.
- b. ASTM E1641-99, *Standard Test Method for Decomposition Kinetics by Thermogravimetry*, Philadelphia: American Society for Testing and Materials, 2000.

MIL-STD-1751A

Method 1074
Determination of Critical Temperature and Self-Heating Properties

1. TYPE OF TEST: Thermal Stability

2. PURPOSE: The analyses described in this Method can be used both to predict and to experimentally determine the critical temperature and self-heating properties associated with a given energetic material. In general, the assumed geometry for self-heating should always take into account the worst case scenario for any given charge size.

3. BACKGROUND: When an energetic material is slowly subjected to an elevated temperature for a prolonged period of time, the material may undergo the phenomenon of self-heating. In this process, thermal energy is liberated in the interior of the explosive as a result of slow chemical decomposition. At some point, a state of equilibrium exists at which the energy released by the thermal decomposition process is equal to the energy dissipated by the system. If the thermal energy is released at a faster rate than it is dissipated, the temperature of the explosive will increase until a catastrophic event occurs. This event, generally referred to as slow cookoff, is associated with the material's critical temperature. The critical temperature is defined as the lowest constant surface temperature above which a given energetic material of a specific size and shape will catastrophically self-heat. Critical temperature is a heat balance between heat generated and heat lost for a given mass and geometry of an explosive or propellant.

4. TEST ARRANGEMENT:

4.1 The experimental data obtained from DTA/DSC/TGA experiments described in Methods 1071 through 1073 can be used to determine the various kinetics parameters required in this method, i.e., Arrhenius activation energy and pre-exponential. These parameters may be associated with a given chemical decomposition reaction or may describe the global process. Numerous methods for calculating kinetics parameters by using the thermal data acquired from Test Methods 1071 through 1073 are available (References a through h). These parameters can then be used to calculate the critical temperature and self-heating properties associated with a particular explosive of a given size and geometry

4.2 The experimental critical temperature for an explosive of a given size and geometry may be determined by carrying out a variety of tests where the explosive may be confined or unconfined. These tests include an isothermal cookoff (ICO), slow cookoff (SCO), one-liter cookoff (1-LCO) and the isothermal Time-To-Explosion (Henkin TTE), where the ICO and SCO are large-scale and confined, the 1-LCO is large-scale and unconfined and the Henkin TTE is very small-scale and moderately confined. The design of the first three tests must incorporate the use of at least one thermocouple placed at the geometrical center of the explosive and one to monitor the temperature of the heat source.

5. PROCEDURE:

5.1 The critical temperature, T_c , associated with an explosive can be calculated for a given size and shape by using equation 1, which is commonly referred to as the Frank-Kamenetskii (F-K) equation (Reference (e)). Two equivalent forms of this equation are given below:

$$(1) \quad T_c = E_a / R \ln((a^2 Q Z E_a) / (c \delta R T_c^2 \Omega)) \quad \text{or} \quad T_c = E_a / R \ln(a^2 \rho Q Z E_a / T_c^2 \lambda \delta R)$$

(a)

(b)

where

MIL-STD-1751A

T_c	=	critical temperature ($^{\circ}\text{K}$)
E_a	=	Arrhenius activation energy (cal mol^{-1})
Z	=	pre-exponential (s^{-1})
a	=	a dimension (e.g., radius of a sphere or infinite cylinder or half-thickness of an infinite slab)
Q	=	heat of the self-heating reaction (not detonation or combustion) (cal g^{-1})
c	=	specific heat ($\text{cal g}^{-1} \text{ } ^{\circ}\text{C}^{-1}$)
δ	=	shape factor (2.0 for infinite cylinders, 3.32 for spheres, 0.88 for infinite slabs and 2.7-2.8 for cylinders with length equal to diameter)
Ω	=	thermal diffusivity ($\text{cm}^2 \text{ s}^{-1}$)
R	=	gas constant ($1.987 \text{ cal mol}^{-1} \text{ } ^{\circ}\text{K}^{-1}$)
ρ	=	density ($\text{g (cm}^3\text{)}^{-1}$)
λ	=	thermal conductivity ($\text{cal cm}^{-1} \text{ s}^{-1} \text{ } ^{\circ}\text{C}^{-1}$)
$(c\Omega)^{-1}$	=	$\rho\lambda^{-1}$

5.2 Arrhenius activation energies (E_a) and associated pre-exponentials (Z) for global thermal decomposition processes may be determined in a time-efficient manner by using variable heating rate (DSC) methods as described in references (a) and (h). Other methods, as deemed appropriate by the researcher, may also be used to determine these parameters. While these methods for determining global parameters generally provide adequate data, the most accurate critical temperature will be predicted by using kinetics parameters that actually correspond to the component reaction involved. Some specific examples of data acquisition and use are provided in reference (g).

5.3 Thermal diffusivity (Ω) of the explosive to be tested may be determined by the method described in reference (g) and used in equation 1(a). Thermal conductivity of the explosive can be determined from the thermal diffusivity measurement, obtained under non-steady state conditions, by the relationship, $\lambda = \rho c \Omega$. On the other hand, the thermal conductivity can be estimated to be in the range 2 to $13 \times 10^{-4} \text{ cal cm}^{-1} \text{ s}^{-1} \text{ } ^{\circ}\text{C}^{-1}$ and then the critical temperature reported as a range (Reference e). For the most part, the critical temperature calculated by using global kinetics parameters and the above stated thermal conductivity range is a conservative value. A conservative value is useful when used in conjunction with safety characteristics associated with scaling up a melt casting operation.

5.4 An experimental critical temperature for a particular size and geometry can be obtained from isothermal tests, such as the ICO (see 4.2 above). Test conditions in which the charge surface temperature, T , exceeds that of the T_c value are described by the relationship:

$$(2) \quad 1/T_c = 1/T + X/E_a$$

where the value of X is defined in reference (f).

Experimental cookoff data are plotted as logarithm of the time-to-explosion, $\log t_c$, versus the reciprocal of the temperature of explosion (T_c). A straight line is then fitted to the data and a point on the line is located that corresponds to $t_c = \Pi$, the thermal time constant. This constant is defined as:

$$(3) \quad \Pi = a^2/\Omega$$

The experimental critical temperature, T_c , is then calculated by using equations (2) and (3). Figure 1 provides an example of how T_c is determined.

5.5 Another method for determining an experimental critical temperature is the isothermal Henkin TTE test as described in reference (k). The critical temperature, T_c , of an experimental explosive is defined as the lowest temperature at which an explosion can be obtained. This simple test provides both times-to-explosion, t_c , and the associated temperature, T_c . It has been reported in reference (k) that a safe failure criterion (no explosion observed) for 40 mg samples in the Henkin TTE configuration, is no explosion in a minimum of 1000 seconds. The Energetic Materials Branch of the Air Force Research Laboratory uses four consecutive tests with no explosion in a 2000-second

Method 1074

MIL-STD-1751A

time period. Data acquired from this test can also be plotted as logarithm of the t_c versus the reciprocal of T_c . This graphical presentation of the data generally yields a linear section at relatively low T_c values (approaching the T_c), then bending sharply upward near the T_c . The plot becomes vertical at the T_c indicating an infinitely long induction period. This data plot sometimes yields a curve with two linear sections with that section at the higher temperatures having longer than anticipated times to explosion (lesser slope). This experimental T_c can be compared to that calculated by using the F-K equation, where a relatively close comparison provides confidence in the parameters used in the equation.

5.6 Dynamic tests that are equipped with at least one thermocouple located at the geometrical center of the explosive and one located in the oven, will also provide an experimental T_c for these specific experimental conditions. Examples of this type of test are the SCO and 1-LCO. The heating rate used in these tests is 3.3 °C/hour and these real-time temperature-time data are acquired by a computerized system. A description of the SCO units is provided in reference (1). Other data gleaned from these tests are the initiation temperature (T_{sh}) associated with the self-heating process and severity of the catastrophic reaction.

5.7 Kinetics parameters may also be obtained from experimental isothermal cookoff temperature-time data obtained from the adiabatic rise of the center temperature of the sample leading to cookoff by using the equation:

$$(4) \quad \rho c dT/dt = \rho Qk = \rho QZ \exp(-E_a/RT)$$

where dT/dt = slope of the center time-temperature trace at a given temperature, T

When the slopes of the center time-temperature traces, $\log(dT/dt)$, versus the reciprocal of the temperature ($1/T$) are plotted for a series of isothermal cookoff tests with differing temperatures, a straight line is obtained. The line will have a slope of $-E_a/2.303R$ and an intercept of $\log QZ/c$. E_a and Z (with knowledge of Q and c) can be calculated from the equations:

$$(5) \quad m(\text{slope}) = -(E_a/2.303R)$$

$$(6) \quad \text{intercept} = \log QZ/c$$

Critical temperature can then be calculated by using equation (1).

6. RESULTS AND DATA:

6.1 The format for reporting calculated and experimental data is at the discretion of the researcher. As a minimum, the calculated critical temperature should be accompanied by the various parameters used in the F-K equation.

6.2 Typical test results for a Navy explosive composition are shown in the table below:

Explosive	Critical temperature (°C)	Diameter, inch	500-day cookoff temp. (°C) (MK 84 bomb)
PBXN-9	233	0.5	129
PBXN-9	201	2.0	
PBXN-9	179	6.0	
PBXN-9	166	12.0	

MIL-STD-1751A

6.3 The calculated and experimental critical temperatures for octol (65/35) in one-liter spherical Henkin TTE geometries, along with input parameters to the F-K equation are shown in the table below (USAF):

Parameter	Value
E_a (cal mol ⁻¹)	50200 ¹
Z (s ⁻¹)	1.49e19 ¹
a (cm) (Henkin TTE/1-LCO)	0.032/6.123
Q (cal g ⁻¹)	500 ²
δ	3.32
R (cal mol ⁻¹ °K ⁻¹)	1.987
ρ (g (cm ³) ⁻¹)	1.67 ³
λ (cal cm ⁻¹ s ⁻¹ °C ⁻¹)	4e-4 ⁴
T_c (°C) (Henkin TTE/1-LCO)	236/154
T_c (°C) (Henkin TTE/1-LCO) ⁵	236/167 ⁶
T_{sh} (°C) (1-LCO)	142

(1) Determined by using the using the method described in reference (h) and the peak temperatures associated with the decomposition of the HMX component.

(2) Assumed value (Reference (h)).

(3) Measured value at 82.6 °C (Reference (i)).

(4) Value adjusted to fit Henkin TTE experimentally determined T_c .

(5) Experimental data, the catastrophic reaction was a combustion that consumed the sample, the one-liter flask was deformed, but in one piece.

(6) Determined by using the one-liter cookoff test (References (i) and (j)). The raw data from reference (i) have been re-evaluated and the values shown in the above table reflect this process.

7. SUPPLEMENTARY INFORMATION:

7.1 Self-heating requirements, as defined in reference (m), provide the acceptance criteria for Navy explosives. This criterion requires that an explosive should have a calculated critical temperature greater than 82°C (180°F) for a given geometry and size, and that the time-to-explosion at 82°C exceeds 500 days. Unless other specific requirements are identified, the assumed charge size for self-heating calculations is that of the MK 84 2,000-pound bomb

7.2 As described in reference (g), two equations are generally used to calculate the 500-day cook-off temperature. Equation (7) allows for the calculation of the Arrhenius rate constant and then the 500-day isothermal cook-off temperature may be calculated from solving equation (8).

$$\ln(1-F^*) = -tk$$

where F^* = fraction or amount of material that reacted during the warm-up period
 t = time to cook off, 4.32×10^7 seconds (500 days)
 k = Arrhenius rate constant

The fraction of material that reacts during the warm-up time (time required to bring the sample up to the oven temperature) is calculated by summing the fractions reacted during 10° increments prior to the center of the sample reaching the oven temperature. This fraction, F^* , can be calculated from experimental isothermal cook-off data and is usually found to be 0.06 ± 0.02 .

7.3 The value for k , the Arrhenius rate constant, can then be substituted into equation (8) to determine the 500-day cook-off temperature.

$$k = A \exp(-E_a/RT)$$

Method 1074

MIL-STD-1751A

where

A = frequency factor
T = cook-off temperature

8. NATIONAL REFERENCES:

- a. Kissinger, H. E., *Journal of Research*, National Bureau of Standards, Vol. 57 (1956), p.217.
- b. Balarin, M. J., *Journal of Thermal Analysis*, Vol. 12 (1977), p. 169.
- c. Petty, M. R. *et al.*, *Journal of Thermal Analysis*, Vol. 11 (1977), p.
- d. Coats, A. N., and Redfern, J. P., *Nature*, Vol. 201 (1964), p. 68.
- e. Rogers, R. N., *Thermochimica Acta*, Vol. 11 (1975), p. 131.
- f. Zinn, J. and Rogers, R.N., "Thermal Initiation of Explosives," *Journal of Physical Chemistry*, Vol. 66 (1962), p. 2646.
- g. Pakulak, J. M., *NWC Standard Methods for Determining Thermal Properties of Propellants and Explosives*, NWC TP 6118, March 1980.
- h. ANSI/ASTM E698-79, "Standard Test Method for Arrhenius Kinetic Constants for Thermally Unstable Materials."
- i. Sprague, C., Aubert, S. and Reich, R., "Characterization of the Sensitivity Properties of (65/35) Fine Grain Octol," AFRL-MN-EG-TR-1998-7031, Air Force Research Laboratory, Munitions Directorate, Eglin AFB, FL 32542-5910, April, 1998.
- j. R.L. McKenney, Jr. and T.R. Krawietz, "One-Liter Test: A Mid-Scale Safety Characterization Test For Melt-Castable Explosives", AFRL-MN-EG-TR-1999-7049, Air Force Research Laboratory, Munitions Directorate, Eglin AFB, FL, July 1999.
- k. Gibbs, T. and Popolato, A. (ed.), "LASL Explosive Property Data," p. 231, University of California Press, Berkeley, CA,
- l. McKenney, R., Summers, P., Schomber, P. and Whitney, S., "Small-Scale Testing of High Bulk Cubical and Spherical Nitroguanidine for Comparative Evaluation," WL/MN-TR-91-44, Wright Laboratory, Armament Directorate, Eglin AFB, FL 32542-5910, February 1991.
- m. NAVSEAINST 8020.5C, Qualification and Final (Type) Qualification Procedures for Navy Explosives, 5 May 2000.

MIL-STD-1751A

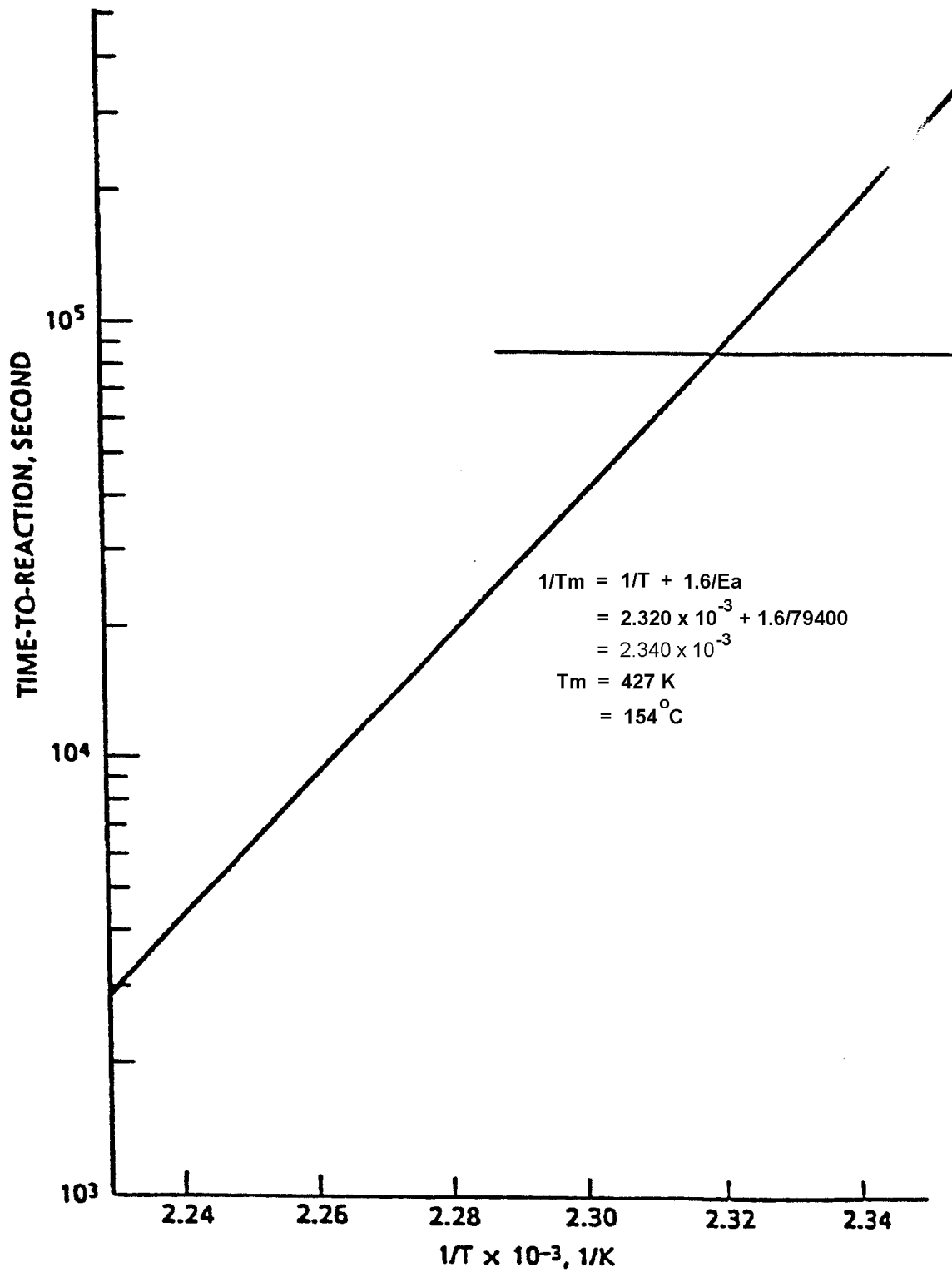
FIGURE 1. Critical temperature determination for 5-inch diameter ICO sample.

Method 1074

MIL-STD-1751A**METHOD 1075****ONE-LITER COOKOFF TEST**

1. TYPE OF TEST: Self-heating: Thermal Stability (Variable Temperature)

2. PURPOSE: A dual-purpose, safety-oriented test designed to determine the self-heating temperature associated with melt-castable energetic materials/formulations and the severity of the unconfined, catastrophic, thermal decomposition reaction. These data are used in conjunction with small-scale safety data to predict the response of the energetic material/formulation to the thermal insult associated with scale-up operations.

3. BACKGROUND: All energetic materials decompose exothermically when exposed to elevated temperature for prolonged times, such as during melt casting operations with large quantities of material. When the decomposition process produces heat faster than it can be dissipated to the surroundings, the energetic material will begin to self-heat. This process may lead to a violent or catastrophic event (explosion). Prior to this test the energy of activation (E_a) and pre-exponential (Z) of the material will have been determined (e.g., through variable heating DSC) and the critical temperature (T_c) for larger scale geometry predicted. The accuracy of a T_c prediction for larger geometry, which is made by using the Frank-Kamenetskii equation along with data generated by small-scale tests, can be determined by conducting the 1-liter test. The latter test will provide insight into the severity of the thermal decomposition reaction, as well as the temperature associated with self-heating.

4. TEST ARRANGEMENT:

4.1 Sample Holder: The sample holder is a 1-liter, Pyrex, round-bottom flask equipped with a thermocouple bundle inserted into the center of the sample and extending to the bottom of the flask. The neck of the flask protrudes through a fitted circular opening in the top of the oven that effectively secures the flask in place during the test. The oven top is sectioned through the centerline of this opening thereby allowing removal of the front section of the top so the neck of the flask can be placed in the opening.

4.2 Thermocouple Bundle: The thermocouple bundle can be constructed with as many as six and as few as two Type k, Inconel encased thermocouples. It is important that one thermocouple touch the bottom of the flask and that the tip of another is located at the center of the flask. If more than two thermocouples are used, one should be located at the top of the spherical portion of the flask and the others, if any, at the mid-point(s) between the

MIL-STD-1751A

bottom/center and/or the top/center. A sixth thermocouple can be located in the neck of the flask if deemed necessary. The bundle can be held in place by any type of clamping device placed on top of the oven. The internal oven temperature is controlled and monitored by two separate thermocouples. All thermocouples are randomly calibrated by using an ice/water bath.

4.3 Disposable Oven: The method used for heating the flask is optional. The method used at AFRL/MNME utilizes a disposable, plywood (5/8-inch thick) oven equipped with a four-element electric resistive heater that is driven by an Omega, Model 650, proportional temperature controller. The four elements are mounted horizontally between the back wall of the oven and a baffle separating them from the main section containing the sample flask. The height of the baffle is 14 inches thereby allowing a one-inch wide gap at the bottom and top for air circulation through the main oven chamber. The elements are placed approximately 8 inches above the floor in a rectangular volume with width, height and depth dimensions of 16, 16 and 6 inches. The inner blade assembly of a small, disposable, double-bladed fan circulates air through the main chamber of the oven by pushing the air through the heated elements. The upper portion of the oven-circulating fan is outside of the oven proper and is designed to cool the fan motor that is positioned on the top of the oven. **It is important that the opening at the top of the one-liter flask is shielded from the draft caused by this cooling fan.** The front door of the oven consists of two 0.375-inch thick glass panes positioned 0.5-inch apart. The panes are held in place by grooves cut into the plywood. The glass front allows the reaction flask to be observed by video camera during the test. The oven is pre-conditioned prior to the test by holding the internal portion at approximately 110 °C for 24 hours. This procedure essentially degasses and slightly chars the internally exposed wood, thus preventing the inside surface of the internal glass pane from clouding over early in the test. After heat conditioning, all seams in the oven are sealed with a heat-resistant, siliconized caulking material.

4.4 Lighting: The inside of the oven is lighted by using an externally placed floodlight

4.5 Data Acquisition: Thermocouple data are collected by using a commercially available program capable of measuring voltage that is converted to temperature (°C). The data are grabbed at predetermined time intervals (time interval is at the discretion of the researcher). The recommended grab time is every 15 seconds. Temperature data should be supported by video data that are acquired for the length of the test. This combination helps in data interpretation.

5. PROCEDURE:

MIL-STD-1751A

5.1 Sample Loading/Preparation: A predetermined amount of sample can either be cast directly into the one liter flask or can be loaded in chunk or powder form. The thermocouple bundle is then inserted into the center of the flask, either in the molten or dry sample. A material with a low coefficient of thermal expansion can be cast directly into the flask, but a sample such as Composition B must be loaded in chunk form in several operations. As is indicated in Section 5.2 below, the oven temperature is raised rapidly to a temperature slightly above the melting temperature of the formulation. A pre-cast formulation with a high coefficient of thermal expansion will expand and crack the flask, hence the need for loading in chunk or powder form. Also, it is desirable, but not mandatory, that the volume of the liquid or liquid/solid mixture match the volume of the spherical portion of the one liter flask at the self-heating temperature to maintain one-dimensionality.

5.2 Sample Conditioning: The sample is heated rapidly (minimum 10 °C/min) to a temperature that is 10 to 20 °C above its melting point and held for approximately 5 hours. This generally provides sufficient time for the sample to be in the molten state and the sample and oven temperatures to have equilibrated.

5.3 Frank-Kamenetskii (F-K) Equation: This Frank-Kamenetskii equation (2) is used to predict the self-heating temperature (estimated temperature leading to the initiation of catastrophic thermal decomposition) for an energetic material of a specific size and configured in a specific geometry. It is used to predict the self-heating temperature for the larger kettles used in melt-casting operations. The various components of the equation, some of which are measured and some estimated, are shown below. The energy of activation, E_a , and pre-exponential factor, Z , are determined by using ANSI/ASTM E698-79. By this method they are global values and, as such, probably do not represent the specific chemical decomposition step responsible for the self-heating event. This will affect the accuracy of the calculated value, but usually leads to a conservative predicted self-heating temperature. Another important component of this equation is the thermal conductivity of the sample at or near the self-heating temperature. While a measured value is preferred, it is generally not available for the desired sample state and temperature of interest. An estimated thermal conductivity range can be used, usually 2 to 13e-4 cal·s⁻¹·cm⁻¹·°C⁻¹, or a value can be extracted from the F-K equation by inserting the experimentally found self-heating temperature (for the one-liter geometry) and the other specific experimental conditions. This extracted value can then be used to predict the self-heating temperature for a specific melt-kettle geometry and casting condition.

$$T_c = E/R \ln(A^2 \rho Q Z E / T_c^2 \lambda \delta R) \quad (1)$$

Where

MIL-STD-1751A

R = gas constant (1.987 cal/mol),
A = radius of sphere, cylinder, or half-thickness of a slab,
Q = heat of decomposition reaction,
Z = pre-exponential factor,
 E_a = energy of activation,
 ρ = density,
 λ = thermal conductivity,
 δ = shape factor (0.88 for infinite slabs, 2.0 for infinite cylinders, 3.32 for spheres).

5.4 Heating Rate: After the equilibration period, the sample is heated at a rate of 3.3 °C/hour until decomposition occurs or the test is terminated for other reasons, e.g., cracking of the flask due to expansion of the sample.

5.5 Self-Heating Initiation Temperature: The oven temperature trace during that portion of the experiment after the equilibration period will be increasing linearly. Ideally, the temperature traces from the thermocouples in the sample will parallel, and generally be located below, that of the oven. Self-heating or thermal lag associated with the sample will cause these temperature traces to veer towards or away from that of the oven, respectively. This change can be magnified by subtracting the temperature associated with any given thermocouple located within the sample from that of the oven for the dynamic portion of the test. This technique allows one to easily detect the temperature at which self-heating initiates. The delta-temperature values generally form a line with an upward slope when plotted against time until self-heating. At this point the delta-temperature/time plot (referred to as a delta-thermogram) will bend downward, usually very sharply. The self-heating initiation temperature is the temperature at which the slope changes from positive to negative. This initial self-heating is not believed to be a catastrophic event, but a time-dependent process producing decomposition products that lead to a catastrophic event.

5.6 Catastrophic Self-Heating: The temperature readings from the thermocouple located at the center of the sample will increase sharply once the catastrophic self-heating process begins, but the temperature associated with this process may not easily be determined directly from the temperature/time trace. This process is no doubt time-dependent and may require isothermal experiments to be adequately described.

5.7 Thermal Decomposition Reaction Severity: The response of the energetic material to this thermal insult may vary from a simple expulsion of material from the flask, probably with associated burning, to a more violent process, e.g., explosion or detonation. Sample expulsion may result from simple thermal expansion to mild to violent bubbling due to gases formed during a relatively slow decomposition process.

MIL-STD-1751A

6. RESULTS AND DATA:

6.1 The following information shall be reported for this test:

- a. Temperature/time data from at least two thermocouples for the sample and one for the oven
- b. Graphical representation of temperature-time data.
- c. Delta-thermogram
- d. Self-heating initiation temperature, determined from the thermocouple in the center of the flask
- e. Final event temperature
- f. The qualitative characteristics of the thermal decomposition reaction

6.2 Representative data for several explosives are given below.

Explosive	Self-Heating Temperature (°C)	Final Event Temperature (°C)	Severity of Final Reaction
Composition B	143-144	199-206	Partial Detonation
Octol (65/35)	142	167	Burn
RDX Classes 1/5 (80/20) Particulate $\rho = 1.2 \text{ g/cm}^3$	154	208	Partial Detonation

7. Supplemental Information: None.

8. National References:

a. McKenney, R.L., Jr. and Krawietz, T.R., One-Liter Test: A Mid-Scale Safety Characterization Test for Melt-Castable Explosives, AFRL-MN-EG-TR-1999-7049, Air Force Research Laboratory, Eglin AFB, FL, July 1999.

MIL-STD-1751A

Group 1090
Test Methods
Critical Diameter

MIL-STD-1751A

Method 1091

Critical Diameter

1. TYPE OF TEST: Performance assessment

2. PURPOSE: This test defines the threshold, d_c , for the propagation of steady-state detonation.

3. BACKGROUND:

3.1 This test measures the failure threshold; therefore, it is far more easily affected by small variations in the physical properties of the charge. Consequently, charges must be of good quality if reproducible results are to be obtained. The charge preparation recommendations of this document should be used. In general, critical diameter should be reported for unconfined explosive charges.

3.2 There are three closely related techniques for measuring the critical diameter. In the first method, a conical charge is initiated at the large end, and the detonation is followed optically or electronically until it fails. In the second method, a stepped cylinder is initiated at the large end and the progress is followed through various sections. In the third method, a series of cylindrical charges of different diameters are used to map the detonation velocity versus the diameter relationship. By keeping the difference between the diameters small, the average of the smallest diameter charge that gives a steady-state detonation and the largest charge that does not, will give a reasonably accurate value of failure diameter. The first two methods will tend to give estimates of the critical diameter that are smaller than the true critical diameter.

4. TEST ARRANGEMENT: The specific procedure to be used, as described in section 5 below, is at the discretion of the experimenter. In all cases, the sample should be representative of the anticipated service use configuration.

5. PROCEDURE:

5.1 Method 1:

5.1.1 For the conical charge with continuous wire electronic method, an explosive charge is prepared with embedded continuous resistive wires. A copper wire of essentially zero resistance is placed parallel to a nichrome wire (No. 40 wire with a resistance of about 2.3 ohms/cm) of known resistance within the cast explosive. A constant current source of about 200 mA is connected between the copper and the nichrome wires. The detonation front, which has a low resistance, completes the circuit. A voltmeter (oscilloscope) reads the potential difference between the copper and the nichrome wires (see figure 1).

5.1.2 From Ohm's Law ($R=E/I$), the resistance R of the nichrome wire remaining in the circuit can be obtained. Since the resistance of the nichrome wire per unit length is known, the distance to the detonation front can be determined. The embedded wires, however, do cause perturbations in the threshold conditions and are a source of error for this technique. From the resistance versus time record, the distance versus time data can be calculated. The distance-time data is differentiated to obtain the detonation velocity. Figure 2 displays the detonation velocity versus the position in the cone for a particular charge and shows the decrease in the detonation velocity down to the value at the critical diameter. When the cone angle is known, the value of the critical diameter can be calculated.

MIL-STD-1751A

5.1.3 To avoid the problems associated with the embedded wires, the detonation may be followed optically with the smear camera. For a steady detonation, the streak is straight. For a failing detonation, the streak is curved and may disappear altogether. With this technique it is not necessary to determine the instantaneous velocity of the detonation from the curved traces. The observation that the trace is definitely curved in the direction of decreasing velocity is sufficient to show that the test diameter is d_c . This prevents the requirement of differentiation of experimental data. It is important to have a sufficiently long charge because as d approaches d_c , the shock-induced reaction may run for long distances at apparently constant velocity before failure can be seen. Reference (a) provides a detailed description of this test method.

5.2 Method 2: The most direct method of determining d_c is to fire a series of different diameter charges and obtain the smear camera record of each. For castable materials which can easily be prepared as conical charges, the record of the reaction initiated at the cone base will show failure at some diameter of the cone. This measured d_c is always too small because in a base initiated conical charge the detonation is overboosted as it progresses to the smaller diameters. The use of a stepped cylinder, instead of a cone, avoids this problem but introduces others. The length of each step or diameter must be about $4d$ or greater to allow the overboosting to fade out and a sufficient length of steady state propagation to measure detonation velocity (D). The camera cannot view an extremely long charge and still give a record that can yield an accurate value of D . Hence, the stepped cylinder, like the cone, is best suited for obtaining a preliminary and approximate value of d_c . Both of these methods should be followed by more precise measurements on cylindrical charges.

5.3 Method 3: For measurements on cast cylindrical charges, the charges should be prepared from one uniform batch of explosives. If the charges are prepared from a melt cast explosive, conditions must be carefully controlled to ensure that all charges have the same physical properties. If the charges are pressed, isostatic pressing is recommended in preference to ram pressing. However, this method requires machining the pressings to make cylinders of the required dimensions.

6. RESULTS AND DATA:

- 6.1 The following information shall be reported for this test
- a. geometry and dimensions of the charge
 - b. nature of any confinement
 - c. method of initiation
 - i. booster explosive
 - ii. booster geometry and dimensions
 - iii. weight of booster
 - iv. density of
 - d. method of recording the progress of the detonation (e.g., streak camera, framing camera, ionization pins).
 - e. criterion for determining that the detonation has failed.
 - f. critical diameter of the candidate

6.2 Table I lists critical diameters reported in references (b) and (c) for several explosives

MIL-STD-1751A

7. SUPPLEMENTARY INFORMATION:

7.1 The range in d_c over all explosives is very large. Common pressed explosives have a d_c of about 1 cm or less whereas voidless composite propellants may exhibit a d_c of several meters. Very sensitive and energetic explosives usually have very small critical diameters. It is very difficult to make cylinders of sufficiently small diameter for measurement purposes. These small cylinders may also be difficult to initiate properly. For these materials, the use of Test Method 1092 is recommended. Another technique for sensitive explosives is the measurement of the so-called initial height of a wedge of explosives and to relate the critical height to critical diameter. Use of this procedure is discussed in Test Method 1046.

7.2 From the discussions of this test and the references cited herein, it is clear that there is no well-defined test for critical diameter that is applicable to all explosives at all diameters. Therefore, the evaluator of a material may investigate and use other techniques to characterize and define the critical diameter. If other methods are used, a description of that technique should also be provided with the test results.

8. NATIONAL REFERENCES:

a. Jaffe, I. and Price, D., *Progress Report on Adaptation of Continuous Wire Method for Measuring Transient Phenomena*, NOLTR 63-163 (Sep 1963), U.S. Naval Ordnance Laboratory, White Oak, Silver Spring, MD (now Dahlgren Division, Naval Surface Warfare Center, White Oak Detachment).

b. Hall, Thomas N. and Holden, James, NSWC MP88-116, *Explosion Effects and Properties*, Navy Explosives Handbook, Part III, October 1988.

c. Dobratz, B., *LLNL Explosives Handbook, Properties of Chemical Explosives and Explosive Simulants*, Lawrence Livermore National Laboratory, UCRL-52997, January 1985.

MIL-STD-1751A

TABLE I. Critical diameters for various unconfined charges.

Material	Density (g/cm ³)	d _c (mm)
50/50 Pentolite (cast)	1.70	6.7
Comp B (A) (cast)	1.71	4.3
Comp B-3 (cast)	1.73	6.2
75/25 Cyclotol (cast)	1.75	6.0 to 8.0
DATB (pressed)	1.72	5.3
PBX-9404 (pressed)	1.82	1.2
Comp A-3 (pressed)	1.63	<2.2
TNT (pressed)	1.63	2.6
PBXN-9 (pressed)	1.73	<2.8
PBXN-7 (pressed)	1.70	<6.4
PBXN-301 (extruded)	1.53	0.36
PBXN-110 (cast)	1.67	6.1

MIL-STD-1751A

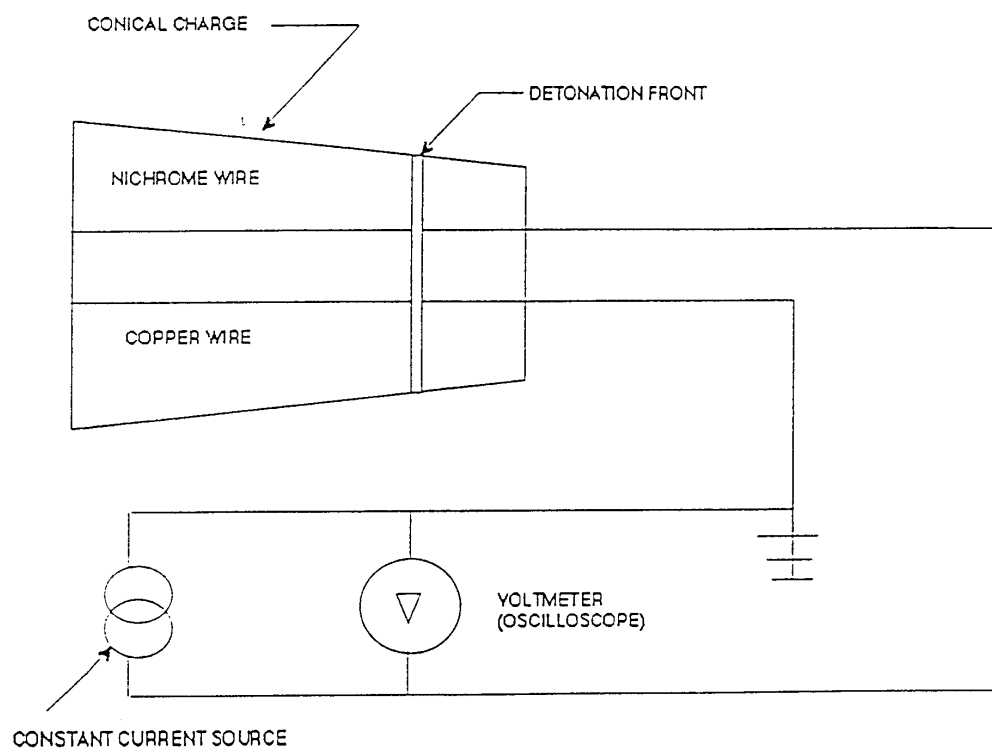

FIGURE 1. Oscilloscope reads the potential difference between the copper and nichrome wires.

MIL-STD-1751A

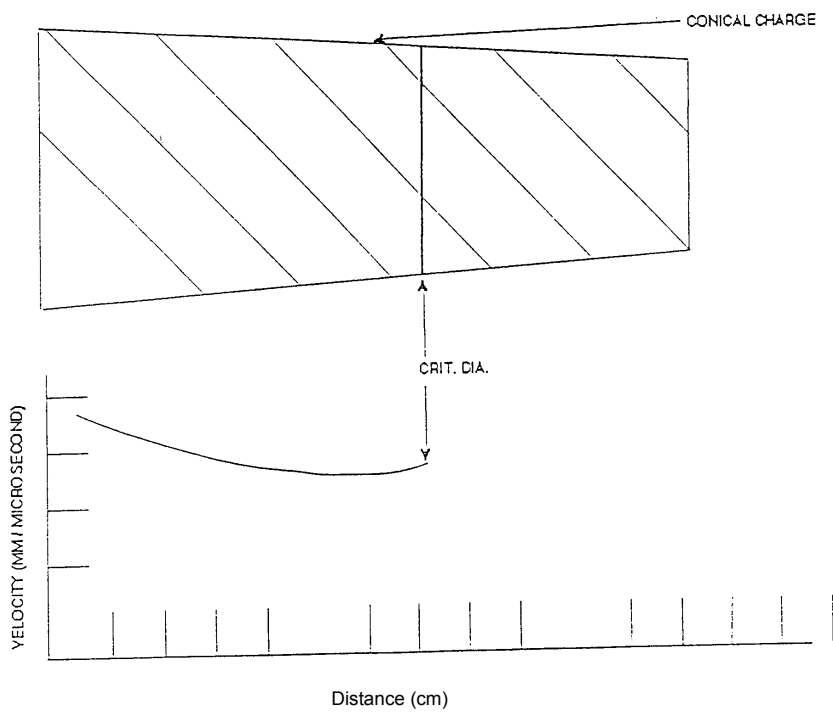
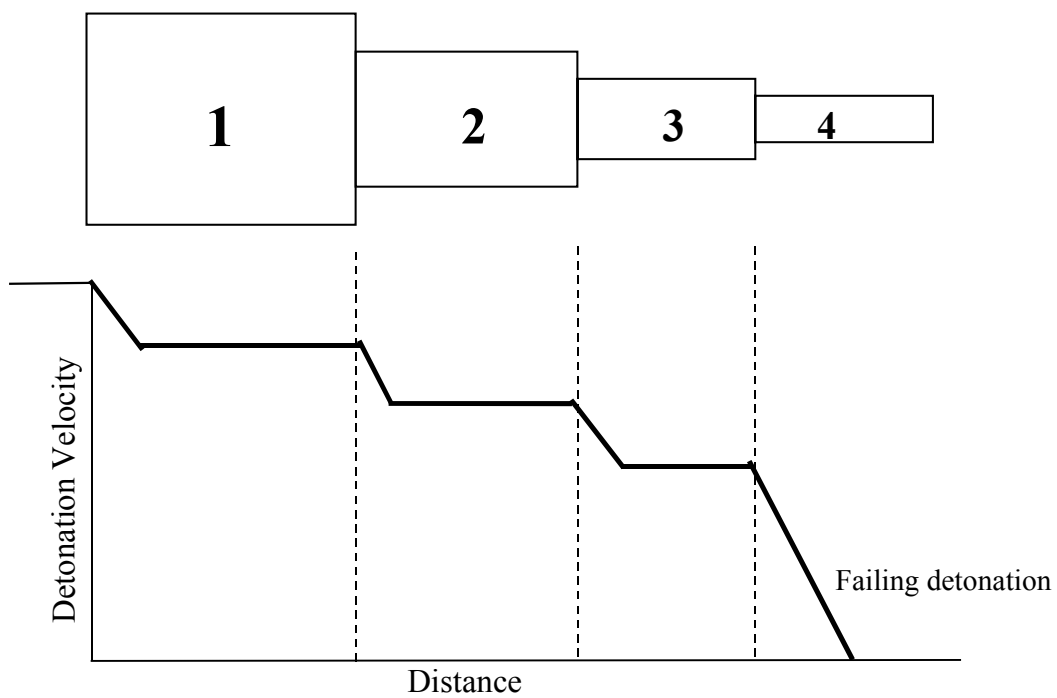

FIGURE 2. Detonation velocity vs. position in the cone.

MIL-STD-1751A



Critical diameter is between the diameters of sections 3 and 4.

FIGURE 3. Change in detonation velocity with decreasing diameter.

MIL-STD-1751A

Method 1092

Very Small Critical Diameter

1. TYPE OF TEST: Performance Assessment

2. PURPOSE: This test defines the threshold, d_c , for the propagation of a steady-state detonation. This procedure is applicable to injection loaded explosives that have a critical diameter in the order of 0.010 inch (0.025 cm) or less.

3. BACKGROUND: This test is a failure threshold; therefore, it is more easily influenced by small variations in the physical properties of the charge than is the value of the detonation velocity at larger diameters. Consequently, charges must be of good quality if reproducible results are to be obtained. The test was specifically developed for performing quality assurance studies on the explosive

4. TEST ARRANGEMENT: The failure thickness is determined by firing three samples in the test arrangement as depicted in figures 1 and 2.

5. PROCEDURE:

5.1 Prior to loading, the base and cover plates should be cleaned to remove any contaminants. The groove of the test item is filled with explosive so that there are no gaps, voids, or inclusions in the loaded channels and that the entire length of the groove is filled with the test material flush to the top. If the explosive composition is a curable explosive, the uncured explosive will be loaded into the test hardware and fully cured prior to testing.

5.2 Mount the cover plate on the test sample using an appropriate adhesive. Care shall be taken to ensure that the flat face of the cover plate is in full contact with the surface of the base plate and the test explosive

5.3 Install the mild detonating fuse (MDF) and shock absorbing tubing in the cover plate to ensure that the end of the MDF is in contact with the test explosive.

5.4 After firing the test item, the distance from the reference end of the aluminum cover plate to the end of the detonation imprint (D in figure 2) shall be determined to ± 0.001 inch.

MIL-STD-1751A

6. RESULTS AND DATA:

- 6.1 The following information shall be reported for this test:
- a. dimensions of the test unit (A, B, and C in Figure 2) to within ± 0.001 inch
 - b. materials of construction of the test fixture
 - c. failure thickness for candidate explosive

6.2 The failure thickness is calculated as follows:

$$\text{Failure Thickness } (d_f), \text{ inch} = \frac{C}{A} (D - B)$$

7. SUPPLEMENTARY INFORMATION: None

8. NATIONAL REFERENCES:

- a. MIL-E-82740, dated 15 Oct 1986, *Explosive, Plastic-Bonded, Injection Moldable (PBXN-301)*, para. 4.5.6, Failure Thickness.

MIL-STD-1751A

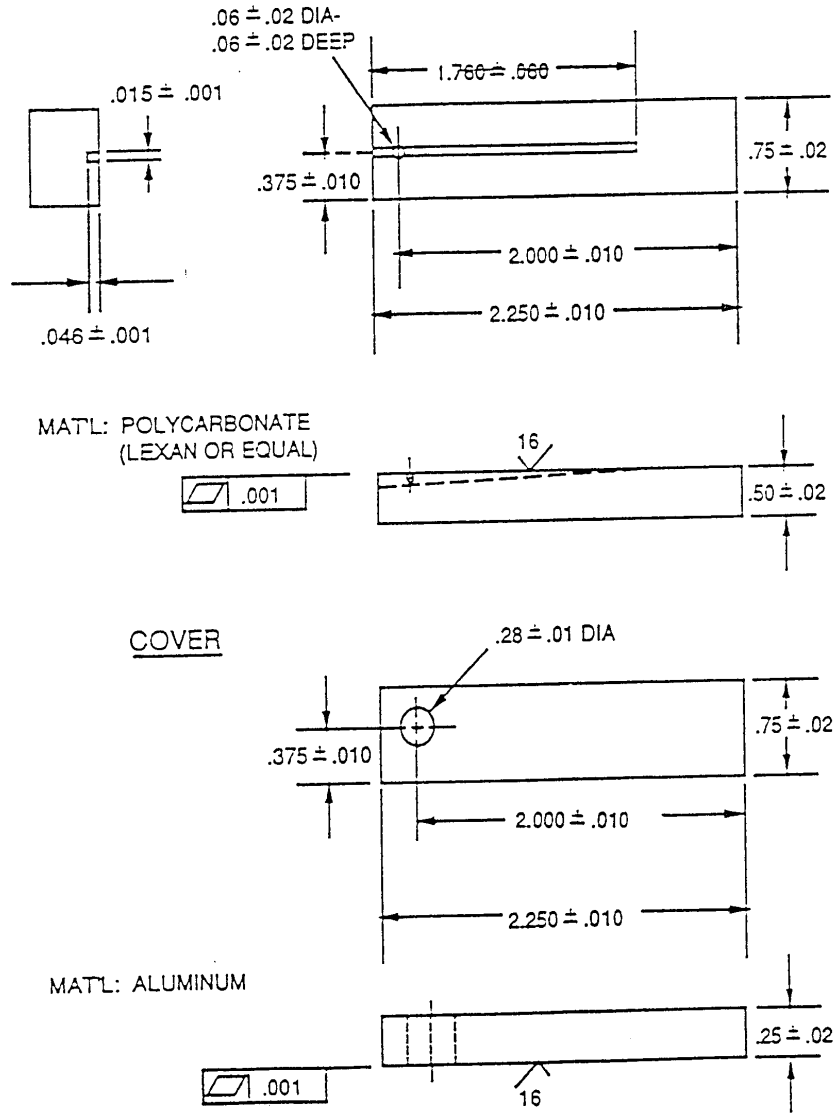

NOTE: All dimensions are in inches.

FIGURE 1. Test item, d_c.

MIL-STD-1751A

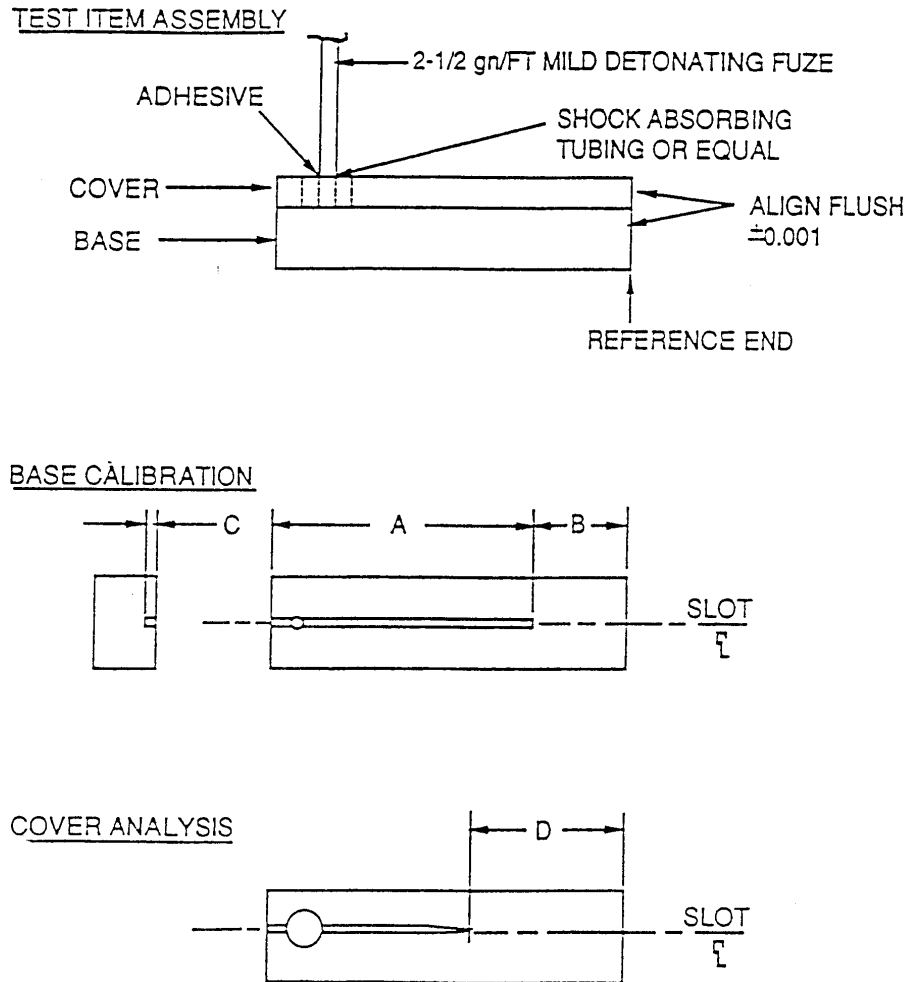

FIGURE 2. Failure thickness test item assembly and analysis.

MIL-STD-1751A

Group 1100
Test Methods
Detonation Velocity

MIL-STD-1751A

Method 1101

Detonation Velocity Test

1. TYPE OF TEST: Performance

2. PURPOSE: To determine the detonation velocity of an explosive and to characterize the explosive for application, performance, and safety.

3. BACKGROUND: One of the characteristic properties of an explosive composition is its detonation velocity, i.e., the velocity at which a steady state detonation wave will propagate through the material. The detonation velocity depends on the material composition of the explosive, the density at which it is tested, the geometry and dimensions of the test, the presence or absence of confinement, and the nature of any confinement around the charge. The relationship between detonation velocity and charge diameter for cylindrical charges is given by equation 1.

$$D(d) = D_{\infty} \left(1 - \frac{a}{d}\right) \quad (1)$$

$D(d)$ = *detonation velocity at diameter d*

d = *charge diameter*

D_{∞} = *detonation velocity at infinite diameter*

a = *constant*

4. TEST ARRANGEMENT: Numerous methods currently exist for the measurement of the detonation velocity of energetic materials. Rather than provide a description of all tests which are suitable, the following recommendations are provided which can be applied to any of the methods.

4.1 Cast or pressed samples should be prepared in sufficiently large size to minimize the charge diameter effect. If a measurement of the critical diameter has been made, this can give direction to the selection of a suitable charge size. If not, an estimate may be obtained by analogy to known explosives. Detonation velocities may be measured on bare charges or confined charges, but the conditions should always be specified.

4.2 Detonation velocities may be measured either by methods that give a continuous record (e.g.,

MIL-STD-1751A

streak camera), or by methods that give measurements at discrete points, as when pin switches are used to record arrival time of the detonation wave. In the latter case more than two pins should be used to give multiple intervals over which to determine the velocity.

4.3 The length of the charge (l) should be sufficient to allow a steady state velocity to be achieved in the charge for a significant fraction of the charge length. In general, a length to diameter ratio of 3/1 is preferred.

5. PROCEDURE:

5.1 As noted above, there are many ways to measure detonation velocity, and the specific procedure to be followed will depend on the test set-up selected.

5.2 Test results should be reported describing average and individual measured velocities, test charge configuration including dimensions, confinement (if any), %TMD, charge density, and boosting design. Table I provides a summary of the detonation velocity of several commonly used unconfined explosives.

6. RESULTS AND DATA:

6.1 The following information shall be reported for this test:

- a. geometry and dimensions of the
- b. nature of any confinement (materials of construction and thickness)
- c. method of initiation
 - i. booster explosive
 - ii. booster geometry and dimensions
 - iii. weight of
 - iv. density of
- d. method of recording the progress of the detonation (e.g., streak camera, framing camera, ionization pins)
- e. number of charges for which detonation velocity was measured
- f. section of the charge over which detonation velocity was measured
- g. individual and average velocities, if multiple measurements were made.

6.2 Table I lists detonation velocities reported for several explosive compositions.

7. SUPPLEMENTARY INFORMATION: None.

MIL-STD-1751A

8. NATIONAL REFERENCES:

a. Hall, Thomas N. and Holden, James , NSWC MP88-116, Explosion Effects and Properties, Navy Explosives Handbook, Part III, October 1988.

b. Dobratz, B., Explosives Handbook, Lawrence Livermore National Laboratory, UCRL-52997, January 31, 1985.

TABLE I. Detonation velocity test results.

Explosive	Charge Diameter (cm)	Density (g/cm ³)	Detonation Velocity (m/s)
TNT (cast)	5.08	1.62	6850
TNT (cast)	6.0	1.62	6980
Pentolite (pressed)		1.71	7750
Pentolite (cast)		1.64	7530

MIL-STD-1751A

Group 1120
Test Methods
Flash Point

MIL-STD-1751A

Method 1121

Flash Point - Liquid Explosives

1. TYPE OF TEST: Ignition

2. PURPOSE: This test is designed to measure the temperature where the sample will emit vapors that may be ignited by an open flame. The test methods, references (a) and (b), cover the determination of the flash and fire points of organic liquids except those having an open cup flash point below 175 °F.

3. BACKGROUND: This test is used for hazard classification in storage, shipping, and operational conditions.

4. TEST ARRANGEMENT:

4.1 A test cup is filled to a specific level with the sample. The temperature of the sample is increased rapidly at first and then at a slow constant rate as the flash point is approached. At specific intervals a small test flame is passed across the cup. The lowest temperature where the application of the test flame causes the vapors above the surface of the liquid to ignite is recorded as the flash point. To determine the fire point the test is continued until the application of the test flame causes the sample to ignite and burn for at least 5 seconds. The apparatus should be supported on a level steady table in a draft-free room or compartment. The top of the apparatus should be shielded from strong light by any suitable means to permit ready detection of the flash point. The draft of the hood must be adjusted so that the vapors may be withdrawn without causing air currents over the test cup during the final 100 F degree rise in temperature.

4.2 The test cup should be washed with solvent to remove any oil or residue from previous tests. Carbon deposits, if any, should be removed with steel wool. The cup should then be washed with water and dried over a flame or hot plate to remove any traces of water or solvent. The cup should be cooled to at least 100 F degrees below the expected flash point before using.

4.3 Support the thermometer in a vertical position with the bottom of the bulb 1/4 inch from the bottom of the cup. This is located halfway between the center and side of the cup on a diameter perpendicular to the arc of the sweep of the test flame and on the side opposite the test flame burner arm.

5. TEST PROCEDURE:

5.1 Fill the cup at any convenient temperature so that the top of the meniscus is exactly at the filling line. If too much sample has been added to the cup, remove the excess amount by using a medicine dropper. However, if there is sample on the outside of the cup, empty, clean, and refill it. Destroy any air bubbles on the surface of the sample. Viscous samples may be heated (at a temperature not to exceed 100 F degrees below the probable flash point) until they are reasonably liquified before being poured into the cup.

5.2 Light the test flame and adjust it to a diameter of 1/8 to 3/16 inch. A comparison bead is mounted on the commercial apparatus. Apply heat initially so that the rate of temperature rise of the sample

MIL-STD-1751A

is 25 to 30 F degrees/min. When the sample is approximately 100 F degrees below the anticipated flash point, decrease the heat so that the rate of temperature rise of the last 50 F degrees before the flash point is 9 to 11 F degrees/min.

5.3 Starting at least 50 F degrees below the flash point, apply the test flame when its temperature reaches each successive 5 F degree mark. Pass the test flame across the center of the cup at right angles to the diameter which passes through the thermometer. With a smooth continuous motion, apply the flame either in a straight line or along the circumference of a circle having a radius of at least 6 inches. The center of the test flame must move in a horizontal plane not more than 5/64 inch above the plane of the upper edge of the cup and passing in one direction only. At the time of the next test flame application, pass the flame in the opposite direction. The time consumed in passing the test flame across the cup shall be about 1 second. (For consistent results the details of flame size, rate of temperature increase, rate of passing the test flame over the sample, etc., must be followed meticulously.)

5.4 Record the temperature when a flash appears at any point on the surface of the sample as the observed flash point. Be careful not to confuse the true flash with a bluish halo that sometimes surrounds the test flame.

6. **RESULTS AND DATA:** The results of the test and the barometric pressure are recorded at the time of test. When the pressure differs from 760 mm Hg correct the flash point by means of the following equation:

$$\begin{aligned} \text{Corrected flash point} &= F + 0.06(760-P) \\ &\text{or,} \\ &= C + 0.03(760-P) \end{aligned}$$

where:

F = observed flash point to the nearest 5 °F
 C = observed flash point to the nearest 2 °C
 P = barometric pressure in mm Hg

Record the corrected flash point to the nearest 5 °F (2 °C). Report the recorded flash point value as the Cleveland open cup (COC) flash point of the sample tested (see reference (a)). Results should be evaluated if they differ by more than 15 °F and the test was conducted by the same operator. The results submitted by each of two laboratories should be reevaluated if they differ by more than 30 °F.

7. **SUPPLEMENTARY INFORMATION:** None

8. **NATIONAL REFERENCES:**

a. ASTM D92-90, *Standard Test Method for Flash and Fire Points by Cleveland Open Cup*. Philadelphia: American Society for Testing and Materials, 1990.

b. ASTM D93-90, *Standard Test Methods for Flash Point by Pensky-Martens Closed Tester*.

MIL-STD-1751A

Philadelphia: American Society for Testing and Materials, 1990.

MIL-STD-1751A

Group 1130
Test Methods
Detonability of Fuel-Air Explosives

MIL-STD-1751A

Method 1131**Detonability of Fuel-Air Explosives**

1. **TYPE OF TEST:** Detonability
2. **PURPOSE:** To determine the detonability of a fuel-air explosive (FAE) fuel as a function of fuel-air concentration and size of the initiating explosive.
3. **BACKGROUND:** None.
4. **TEST ARRANGEMENT:** A detonation tube is used to determine the detonability of FAE fuels on a small scale. The minimum dimensions of the tube are 60 cm diameter by 180 cm long. A longer tube is desirable, especially for solid fuels. The tube is open on both ends and has the following attachments: hoops at each end for sealing the tube with plastic film, a detonator holder at one end for initiating the fuel-air mixture, pressure transducers and/or velocity gauges along the side of the tube for detecting the passage of the detonation wave, and a fuel dispersal system. For liquid fuels, the fuel dispersal system typically consists of a spray manifold along the top of the tube for spraying the fuel under nitrogen or air pressure. For solid fuels, a manifold along the bottom of the tube is used. Jets of air from the manifold are used to entrain the powdered fuel. In use, the fuel is introduced into the tube. After a short wait to allow time for mixing, the detonating charge is initiated. The signals from the pressure transducers and/or the velocity gauges are used to determine if a stable detonation wave was established in the fuel-air mixture. A typical tube designed for liquid fuels is shown in Figure 1.
5. **PROCEDURE:** The same general procedure is used for both liquid and solid fuels although the fuel dispersal systems are different. The operator should:
 - a. Conduct initial tests at a stoichiometry of 1;
 - b. Use the largest initiator charge that is compatible with the test apparatus; and
 - c. Use three replications.
6. **RESULTS AND DATA:**
 - 6.1 The data recorded for each test is generally as follows: fuel type; fuel quantity; concentration; spray or mix time; ambient temperature, pressure, and humidity; temperature drop caused by evaporation of fuel (optional); type and size of initiator; data records showing closure time for detonation velocity gauges; and data records of the pressure transducer outputs. The data records are assessed to determine the detonation velocity and detonation pressure.
 - 6.2 If a detonation is not obtained, the fuel is not considered a practical fuel for FAE applications.
 - 6.3 If a detonation is obtained, the testing is continued with decreased initiator size and/or off-stoichiometric concentrations until the detonability limits are established as a function of both fuel-air ratio

MIL-STD-1751A

and initiator energy. A typical detonation limit curve that can be developed from this data is shown in figure 2.

7. **SUPPLEMENTARY INFORMATION:** None

8. **NATIONAL REFERENCES:** None

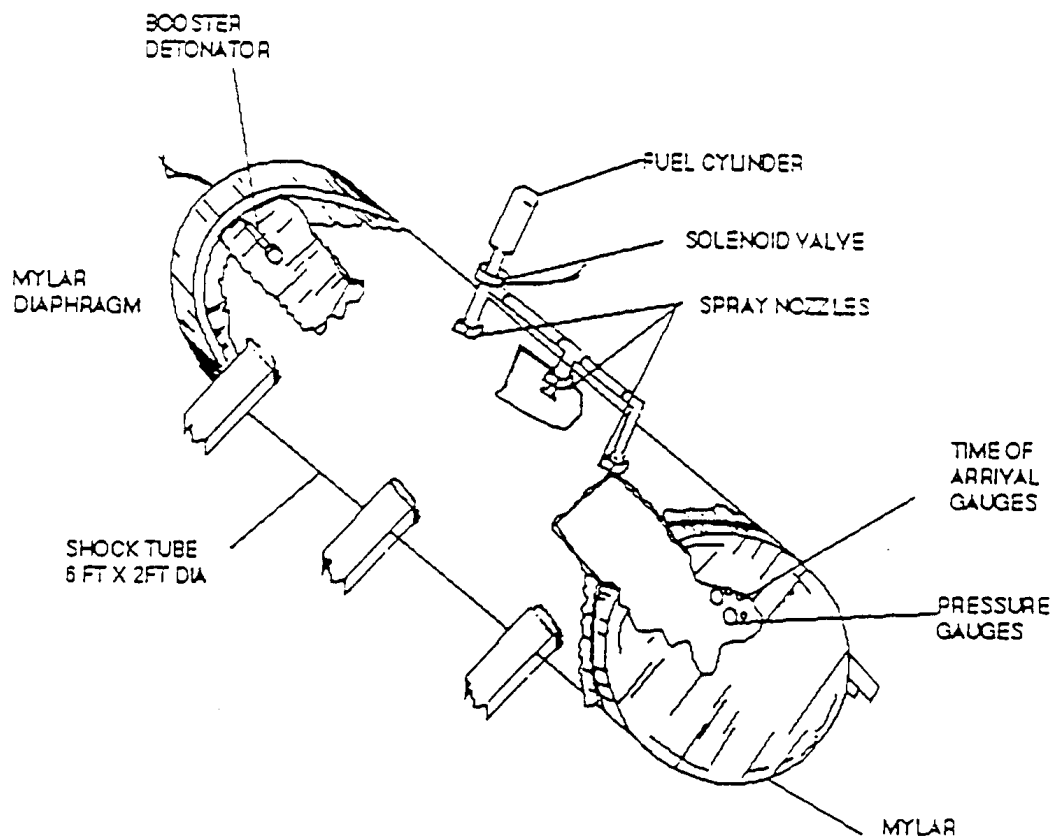

FIGURE 1. Type detonation tube for liquid fuels.

MIL-STD-1751A

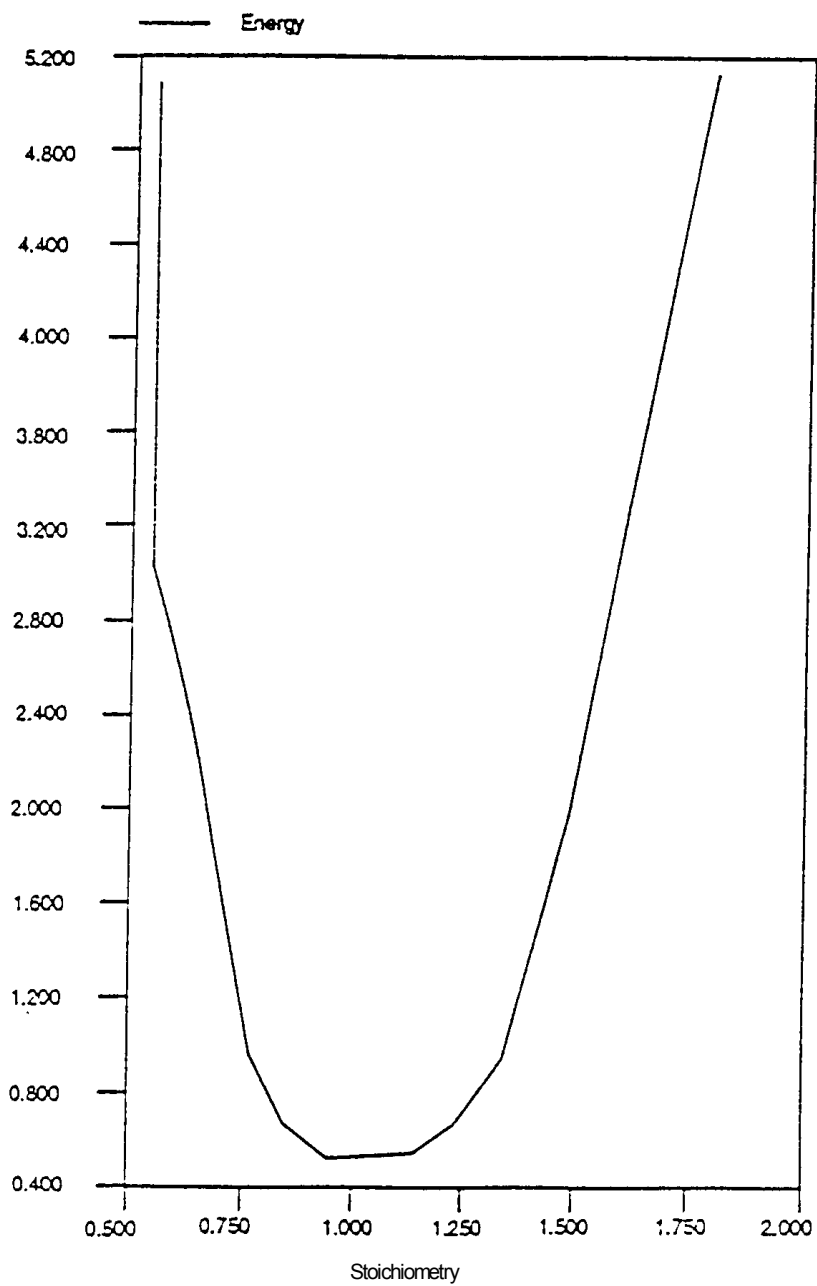

FIGURE 2. Typical detonation limit curve.

MIL-STD-1751A

Group 1140
Test Methods
Minimum Pressure for
Vapor Ignition

MIL-STD-1751A

Method 1141

Minimum Pressure for Vapor Phase Ignition - Liquid Propellants**1. TYPE OF TEST:** Sensitivity

2. PURPOSE: To determine the pressure below the point where it is impossible to ignite a monopropellant vapor or fuel vapor-air mixture by using a fixed quantity of energy applied in a well-defined manner.

3. BACKGROUND: None

4. TEST ARRANGEMENT:

4.1 The test apparatus consists of a thermostat-equipped stainless-steel bomb where the monopropellant vapor or vapor-air mixture is introduced. The temperature and pressure of the internal volume of the bomb can be varied. Vapor ignition is accomplished by the electrical fusion of 0.0025 inch diameter Nichrome V wires. Figure 1 displays a schematic drawing of the test apparatus which consists of the following: (1) a thermostat-equipped stainless steel bomb where the monopropellant vapor is placed, (2) a means of holding the small wires, (3) a means of removing carbonaceous material formed in the explosive decomposition (many of the substances which have been evaluated by this technique have been acetylenic compounds which give large quantities of carbonaceous residue), and (4) an electric current supply. In the present apparatus the wire-fusion time is determined by the voltage applied to the wire and the characteristics of the fuse wire.

4.2 The bomb (figures 2 and 3) was designed with an internal volume of 25 cm³ (liner in) and 45 cm³ (liner out) to permit testing small quantities of fuel. The overall internal volume, including leads and pressure transmitter (figures 4 and 5) is 98 cm³. The stainless steel removable liner also permits sampling and weighing of residual solids after an explosion. The bomb is electrically heated and capable of being regulated from ambient temperature to 260°C by a Fenwal thermostwitch. In this temperature range, sufficiently high pressures can be obtained with most of the higher molecular weight compounds to determine the minimum pressures for vapor-phase ignition.

5. PROCEDURE:

5.1 The sample is introduced in the gas phase from a conventional-heated manifold for handling organic vapors. Fuels with less than adequate vapor pressure are introduced as liquids by means of a syringe-type injector through hypodermic tubing. The tubing site is determined by the physical properties of the liquid fuel. The wire holders are spring loaded, and the wire is threaded through small holes in each post. The spring holds a plunger firmly against the wire so that good electrical contact is made. It becomes necessary when carbonaceous products are formed to clean the holes and the plunger face each time a new wire is threaded.

MIL-STD-1751A

5.2 All measurements have been made with Nichrome V wires, 0.118 inch long, with a diameter of 0.0025 inch.

5.3 In an experiment, the appropriate fusion time and energy are fixed by setting the applied voltage and resistance. Ignition trials are then made at different pressures while the critical pressures between ignition and non-ignition are observed. Occurrence of ignition is indicated by the flash observed through the Pyrex window in the bottom of the bomb by means of a mirror.

5.4 The first operation in making a determination of the minimum pressure for vapor-phase ignition is the adjustment of the Fenwal thermostats (in all parts of the system in contact with fuel vapors) to the setting necessary to maintain the desired temperature. The fuse wire is threaded into the wire holder and the bomb head secured by means of the lock ring. When liquid fuels are being evaluated, the hypodermic tubing is then connected to the fuel injector. When the bomb assembly and all leads have come to equilibrium temperature, the bomb is evacuated. The bomb and leads are flushed and evacuated several times with the fuel to be tested and then evacuated again. The bomb is then filled with vapor to a pressure approximating the estimated minimum pressure for vapor-phase ignition, and the ignition is attempted by fusion of the wire. The voltage and resistance in the igniting circuit have previously been set to give the desired energy and fusion time. If ignition is not obtained, the pressure is increased until ignition occurs. In order to ascertain the point accurately, several additional shots are always carried out at slightly higher and lower pressures. A judicious choice of test pressures reduces the number of tests. The output from the strain gauges is recorded on a voltmeter (a recording potentiometer or oscilloscope is used when the dynamic pressure in the reaction is measured).

5.5 At the completion of each minimum pressure determination, the exact value of pressure is verified by calibrating the pressure transmitter with nitrogen pressure in the bomb and using Bourdon tube gauges which have been standardized by means of a dead weight tester. These gauges are also checked periodically with a Heise test gauge. A vacuum cleaner and stiff brush are used to remove any excess carbon from the bomb. The pressure transmitter is cleaned by flushing it with a high-pressure air jet. Fuels which have vapor pressures above 1.0 atmosphere are admitted to the bomb through the "hot fuel" inlet. The fuel is contained in a small stainless-steel cylinder. A hot oil bath is raised so that the fuel tank is immersed in the oil until the required vapor pressure is obtained in the bomb. The oil bath is lowered immediately to avoid possible decomposition in the fuel tank

6. RESULTS AND DATA:

6.1 Variation in bomb size appears to have an effect on minimum ignition pressure (see table I). The data shown were obtained in an ignition bomb, at 15 to 17°C, similar to that described herein. The ignition source in these experiments was a 10-mm length and 0.5-mm diameter platinum wire with an ignition current sufficient to cause an "instantaneous fusion" of the wire ($H =$ approximately 15 joules).

6.2 If the fuse-wire ignition energy is plotted as a function of the pressure, loops are sometimes obtained in the curve which are dependent upon the fusion time. An increase in energy (applied voltage

MIL-STD-1751A

in the fuse wires) decreases the fusion time. As the fusion time increases, heat loss from the wire due to thermoconductivity and convection effects can be expected to become significant.

6.3 The unusual shape of the ignition energy-pressure curves can probably be explained by a detailed consideration of some of the effects just discussed.

TABLE I. Minimum ignition pressure of acetylene.^{1/}

Bomb Diameter, mm	Minimum Ignition Pressure, atm _{abs}
50	1.80
100	1.60
150	1.45
200	1.40
270	1.40

^{1/} Data extracted from *Acetylene and Carbon Monoxide Chemistry*, Copenhagen, J.W. and Bigelow, M.H., p. 315, New York, Reinhold Publishing Corporation, 1949.

6.4 For comparison of monopropellants, it is necessary to fix some experimental conditions. Thus, the fusion time and ignition energy are held constant (approximately 5 milliseconds and 0.07 joules) and the minimum ignition pressure determined. The results might thus be regarded as giving the lower pressure limit at a given energy level and time for the wire to fuse. Data obtained in this bomb (and in a larger bomb) gave equivalent relative results in comparing the different fuels. Some typical data are reproduced in table II. This table contains the value normally considered for the minimum ignition pressure (the value at $t = 5$ milliseconds and $H = 0.07$ joules). The fusion time and actual energy are indicated. Most work has been attempted at a temperature of 100°C ; however, this is frequently impossible as with n-propyl nitrate because of the lack of sufficient vapor pressure at 100°C to obtain the minimum pressure.

7. SUPPLEMENTARY INFORMATION: Further details on procedures and test equipment may be obtained from reference (a).

8. NATIONAL REFERENCES:

a. *Liquid Propellant Test Methods*, Chemical Propulsion Information Agency (CPIA), July 1969. (Obtainable through the Defense Technical Information Center, DTIC).

MIL-STD-1751A

TABLE II. Comparison of monopropellant ignition characteristics obtained at Experiment Incorporated.

Characteristic	Ethylene Oxide	N-Propyl Nitrate	Acetylene	
	100°C	160°C	100°C	150°C
Minimum Ignition Pressure, atm	2.18	2.2	3.50	5.26
Fusion Time, milliseconds	1.15 to 5.20	2.3	1.2 to 16.0	1.20
Ignition Energy, joules	0.065 to 0.080	0.10	0.074 to 0.090	0.12
Minimum Ignition Pressure, atm, at t = 5 milliseconds, H = 0.07 joules	2.2	2.5 to 3.0	3.5	3.6

MIL-STD-1751A

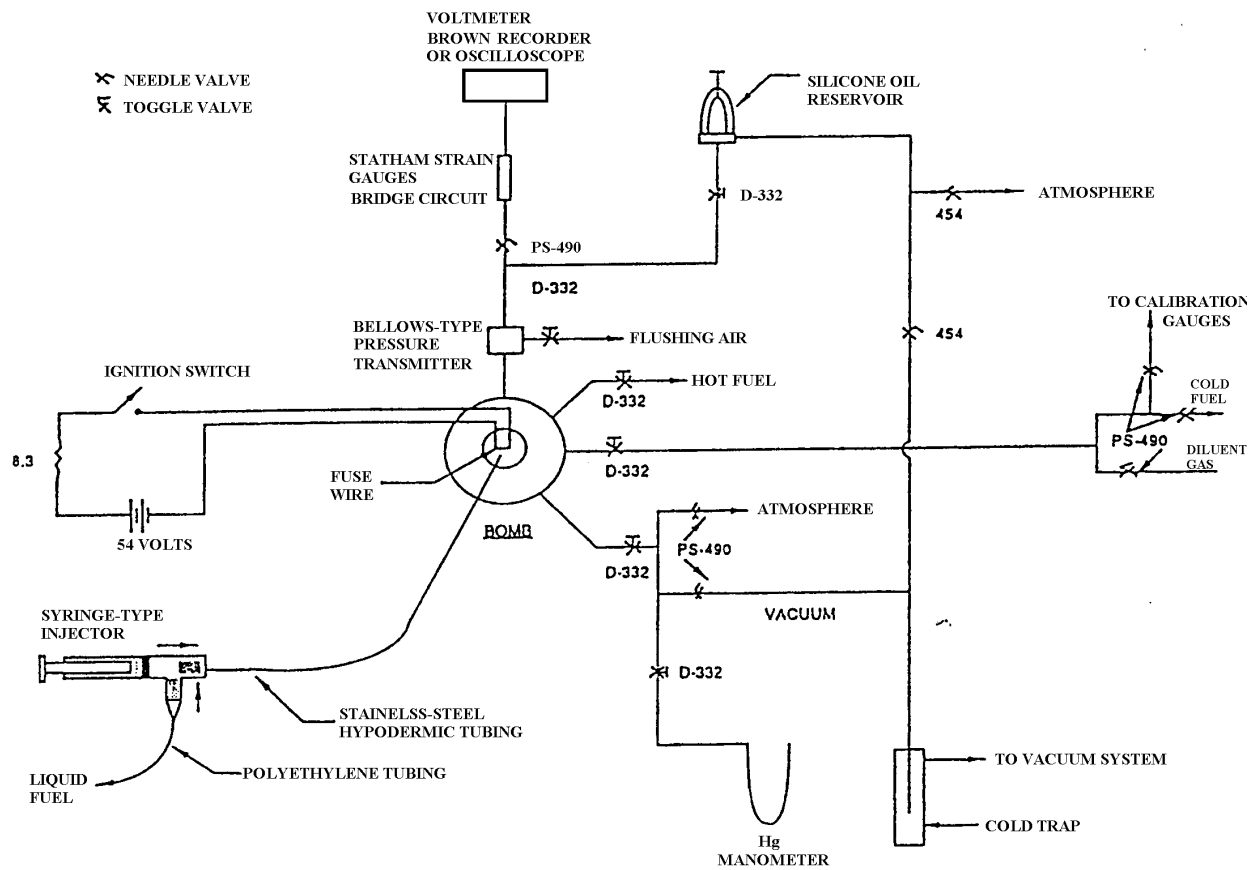

FIGURE 1. Minimum pressure for vapor phase ignition apparatus.

MIL-STD-1751A

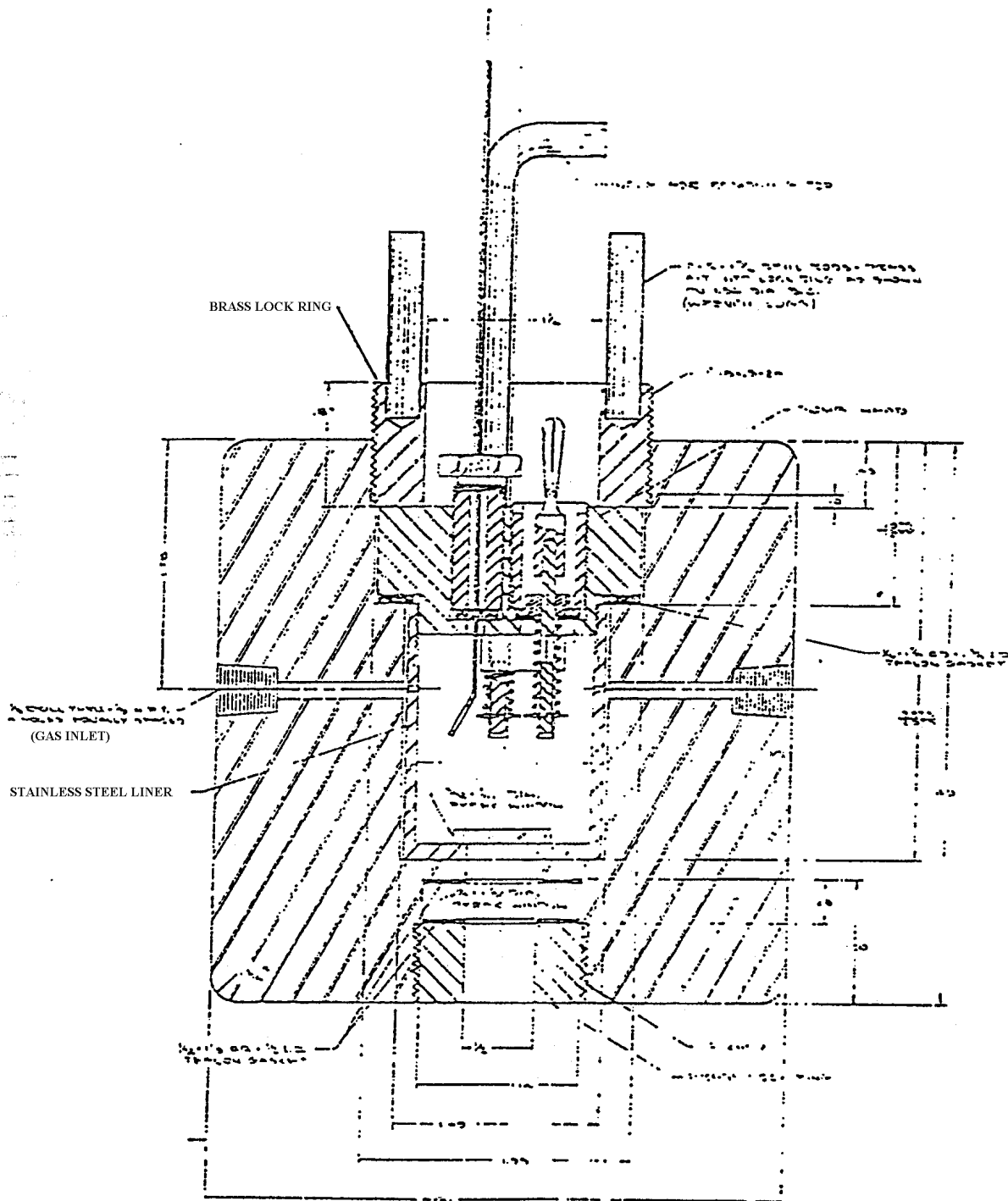
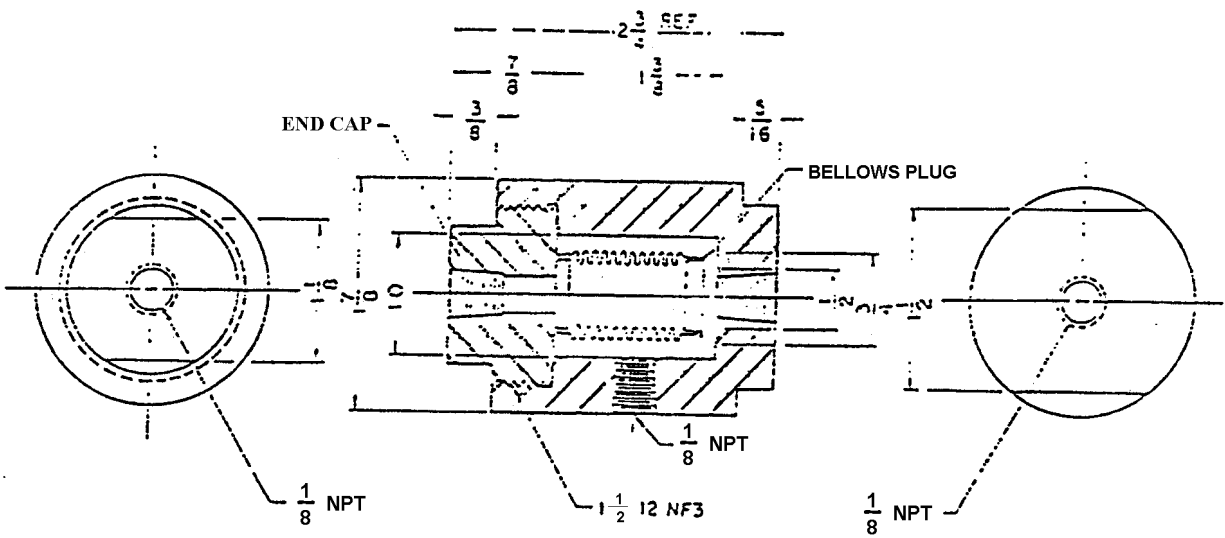

FIGURE 2. Stainless Steel Ignition Bomb.

MIL-STD-1751A



FULL SCALE

NOTE: ALL STAINLESS STEEL ELECTRICALLY WELDED, USE $\frac{1}{2} \times \frac{3}{4}$ SS BELLOWS WITH 12 CONVOLUTIONS, USE ONE PLY- (CHICAGO METAL HOSE CORP)

FIGURE 4. Pressure transmitter.

MIL-STD-1751A

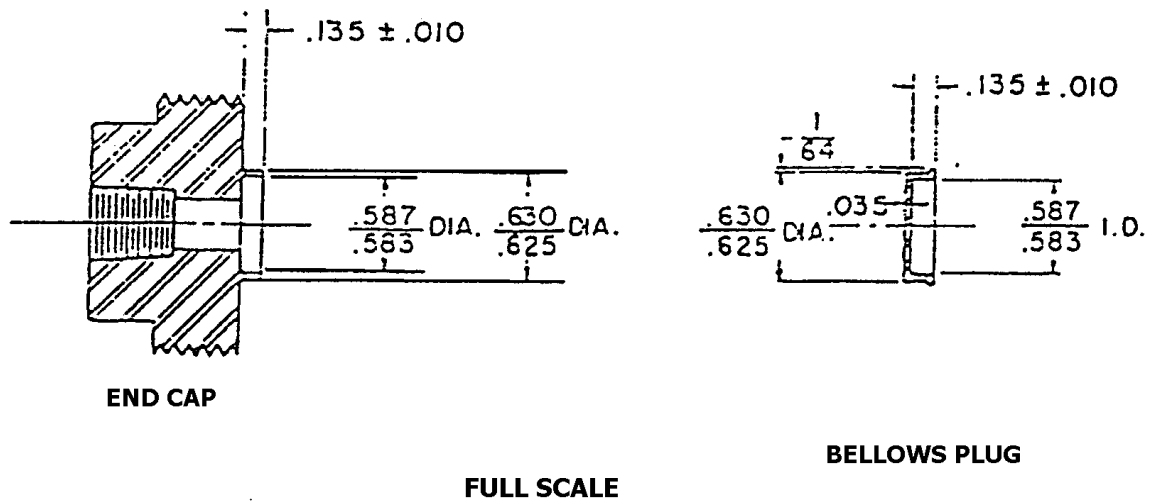

FIGURE 5. Pressure transmitter details.

MIL-STD-1751A

Group 1150
Test Methods
Ignition Sensitivity

MIL-STD-1751A

Method 1151**Hot-wire Ignition Test**

1. TYPE OF TEST: Ignition sensitivity

2. PURPOSE: This test determines the ignition sensitivity of an explosive material in contact with an electrically energized (hot) wire.

3. BACKGROUND: None

4. TEST ARRANGEMENT: The explosive material particle size for this test must be small compared to the diameter of the ignition wire. Therefore, only explosive passing through a 325-mesh sieve shall be used. (There is an exception for extrudable non-curing explosives which shall be extruded directly into the charge holder and onto the bridge wire.) If a minimum of 90% of the explosive as submitted does not pass through a 325-mesh sieve, a representative sample shall be taken and milled. Milling should be conducted under a non-combustible wetting agent that will neither appreciably dissolve nor react with the explosive. The milling shall be accomplished using stainless steel balls or flint pebbles. Milling shall be continued until at least 98% of the sample passes through the 325-mesh sieve. Only that portion passing through the 325-mesh sieve shall be used for this test. The explosive shall be dried to a constant weight at 55°C before being loaded in accordance with 5.1 below.

5. PROCEDURE:

5.1 Loading procedure. Bridge 40 plug subassemblies, drawing 457454 (reference (a)), with a 2-mil-diameter tungsten wire flush with the plug surface (see Figure 1). Firmly attach the spacer, drawing 652246 (reference (b)), to the bridged plug subassembly. Twenty bridged plug subassemblies each shall be loaded with the dry explosive prepared in accordance with section 4 above by pressing the explosive flush to within ± 0.010 inch of the spacer at pressures of 4,000 and 20,000 psi, respectively.

5.2 Firing procedure. Each loaded unit shall be tested with an ohmmeter prior to firing to determine that the tungsten bridge wire is intact. The test unit shall then be placed explosive-side down on an aluminum witness plate, 1.5" x 1.5" x 0.5", and fired in a safety chamber. Firing voltage shall be supplied by a fully charged 12-volt lead-acid automotive storage battery of at least 45 ampere-hours capacity. The battery shall be connected to the test unit by a plunger-type mercury relay (Macke electrical devices or equivalent) through appropriate wiring and safety interlocks. The total circuit resistance, including the relay, wiring, and interlocks, but not the battery or test unit, shall not exceed 0.4 ohm. Testing shall continue until all 40 samples (only 20 samples are necessary for extrudable non-curing explosives) are tested, unless an individual test sample does not meet the requirements of section 6 below.

6. RESULTS AND DATA: The candidate explosive shall be reported to have passed the hot-wire ignition test if none of the 40 samples show any evidence of reaction in the form of visible, audible, or measurable external change to the test explosive, the test unit, or the witness plate. However, the tungsten wire shall have been burned out as determined by an ohmmeter test.

MIL-STD-1751A

7. SUPPLEMENTARY INFORMATION: None

8. NATIONAL REFERENCES:

- a. Naval Sea Systems Command (CAGE Code 10001) drawing 457454 *Plug Subassembly*.
- b. Naval Sea Systems Command (CAGE Code 10001) drawing 652246 *Spacer*.

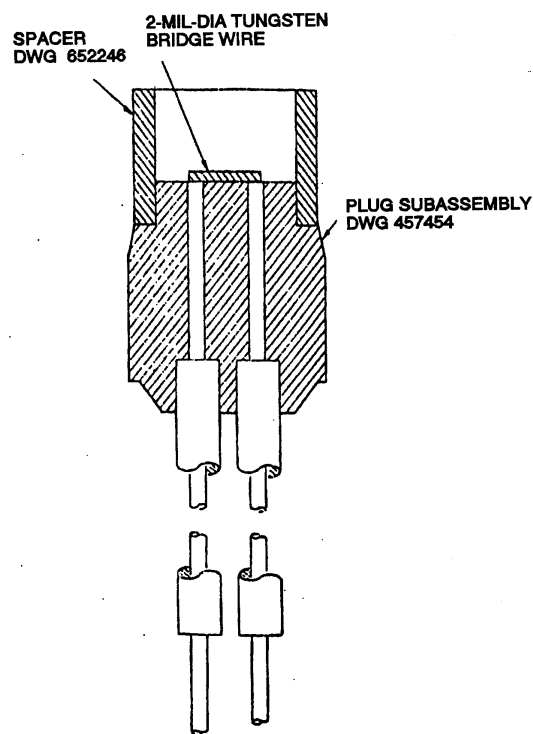

FIGURE 1. Hot-wire ignition arrangement.

MIL-STD-1751A

Group 1160
Test Methods
Exudation and Growth

MIL-STD-1751A

Method 1161**Exudation**

1. TYPE OF TEST: Exudation characteristics

2. PURPOSE: This test is designed to measure the exudation of energetic materials.

3. BACKGROUND: When explosives contain liquids as impurities, the liquids may exude during storage. In explosives containing TNT the dinitrotoluenes form a low-melting eutectic that may cause problems, such as damaging the fuze well or leaking into the detonator areas. Munitions loaded with explosives containing liquid plasticizers have also experienced problems when the plasticizer migrates into the booster charge.

4. TEST ARRANGEMENT:

4.1 The test apparatus consists of an aluminum sleeve (machined from 7075-T6), as shown in Figure 1, with a 26.4mm (1.04 inch) I.D. and 51.8mm (2.04 inch) O.D. by 127.0mm (5.0 inch) long. The sleeve is closed off and sealed at each end by Velumoid or equivalent automotive gaskets, 50.8mm (2.0 inch) dia. by 0.5mm (0.20 inch) thick, and aluminum discs (machined from 7075-T6), 50.8mm (2.0 inch) dia. by 12.7mm (0.5 inch) thick. The aluminum discs are attached to the sleeve by four ¼ “-20, ½” long socket head cap screws equally spaced around a 1.5” diameter bolt circle.

4.2 The test sample is wrapped in a sheet of Watman No. 1 Qualitative or equivalent filter paper, 127.0mm (5.0 inch) wide by 161.9mm (6.375 inch) long. Four discs, 25.4 mm (1.0 inch) in diameter, are cut from the filter paper and placed at each end of the test sample after it is wrapped and inserted into the test fixture.

4.3 A conditioning chamber which operates at the specified temperature and suitable for energetic materials is used to conduct this test.

4.4 The test samples are cylinders 25.4 – 0.0254 mm (1.0 – 0.001 inch) diameter by 125.73 – 0.0508 mm (4.950 – 0.002 inches) long. The test sample may be made up of stacked pellets when pressed explosives are tested. Three test samples are required.

5. PROCEDURE:

5.1 Each test sample is weighed to the nearest 0.0001 gram using an analytical balance, and the mass of each sample is recorded. The filter paper sheets and discs (one sheet and eight discs for each test sample) are placed in a desiccator at room temperature until constant weight is achieved. The filter paper sheets and discs are weighed to the nearest 0.0001 gram using an analytical balance and mass recorded.

5.2 After the weights have been recorded, one sheet of filter paper is removed from the desiccator and tightly wrapped around test sample. The wrapped test sample is then tightly inserted into the aluminum sleeve. Four filter paper discs followed by a Velumoid gasket are placed at each open end of the aluminum sleeve; the aluminum cover discs are then bolted snugly to each end of the sleeve to seal (Figure 1). This procedure is repeated for each test sample.

5.3 The test fixtures are placed in a conditioning chamber at $71 \pm 0.5^{\circ}\text{C}$ ($160 \pm 1^{\circ}\text{F}$) for a period

MIL-STD-1751A

of 320 hours. A continuous recording is made of the chamber temperature. At the conclusion of 320 hours the test fixtures are removed from the conditioning chamber, insulated, cooled to room temperature and disassembled.

5.4 For each test sample, the filter paper wrap and discs are placed in a desiccator at room temperature until constant weight is achieved. The filter paper sheets and discs are reweighed to the nearest 0.0001 gram using an analytical balance and mass recorded. The test samples are reweighed to the nearest 0.0001 gram using an analytical balance and mass recorded.

5.5 The loss in weight for each test sample is recorded as the amount of exudate. The percent exudation is obtained by dividing the amount of exudate by the original sample weight and multiplying by 100. The gain in weight of the filter paper sheet and discs for each test sample is used to confirm the exudate value.

6. RESULTS AND DATA:

- 6.1 The following information shall be recorded from this test
- a. Type of conditioning chamber used to conduct the test (programmable, manual)
 - b. Method used to prepare the test samples (pressing, casting)
 - c. Initial mass, length, diameter and percent of theoretical maximum density of each test sample
 - d. Initial mass of the filter paper sheets and disks
 - e. Time the samples were conditioned at temperature, including temperature record of conditioning chamber
 - f. Final mass of the test samples after 320 hours at temperature
 - g. Final mass of the filter paper sheets and discs for each test sample
 - h. Photographs of the test samples, filter paper and discs after disassembly of the test fixtures
 - i. Description of the appearance of the test samples, filter paper sheets and discs after the conclusion of the test (discoloration, blotches ...)
 - j. Loss in weight for each test sample (amount of exudate)
 - k. The percent exudation values for each test sample based on weight loss of samples
 - l. Weight gain in the filter paper sheets and discs for each test sample
 - m. The percent exudation for each test sample based on weight gain in filter paper sheets and disks
 - n. Average exudation of the three test samples

7. SUPPLEMENTARY INFORMATION: None

8. NATIONAL REFERENCES:

- a. Voigt, H.W., *Exudation Test for TNT Explosive Under Confinement: Exudation Control and Proposed Standards*, ARLCD-TR-83004, Picatinny Arsenal, NJ, February 1983.

MIL-STD-1751A

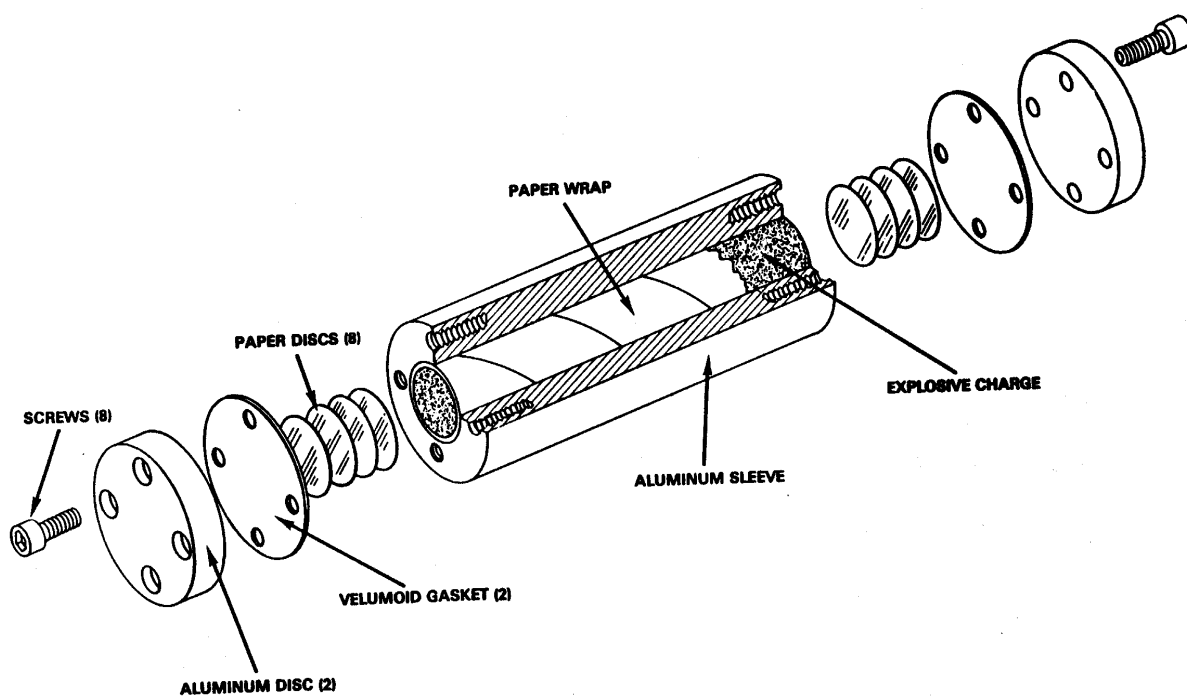

FIGURE 1. Apparatus for exudation test

MIL-STD-1751A

Method 1162

Irreversible Growth

1. TYPE OF TEST: Growth Characteristics

2. PURPOSE: This test is designed to measure the irreversible growth of solid energetic materials.

3. BACKGROUND: When explosives contain liquids as impurities, they often undergo irreversible dimensional changes when subjected to many temperature cycles between -54 and $+71^{\circ}\text{C}$ (-65 and $+160^{\circ}\text{F}$). In explosives containing TNT, the dinitrotoluenes form a low-melting liquid eutectic that can cause problems. Mononitrotoluenes added as anti-cracking agents give large irreversible growth in TNT-based explosives. Another cause for irreversible dimensional change is solid-state polymorphic transformation, such as occurs in ammonium nitrate.

4. TEST ARRANGEMENT:

4.1 A programmable conditioning chamber that operates within the specified temperature range and suitable for energetic materials is used to conduct this test.

4.2 Acceptable test samples are cylinders at least 1.27 cm (0.5 inch) diameter by 1.27 cm (0.5 inch) high, the preferred sample size is 2.54 cm (1.0 inch) diameter by 2.54 cm (1.0 inch) high.

5. PROCEDURE:

5.1 Three test samples are conditioned to $20 \pm 2^{\circ}\text{C}$ ($70 \pm 3^{\circ}\text{F}$) weighed and carefully measured to the nearest 0.01mm (0.0005 inches) using a micrometer or calipers. The initial mass, length and diameter (measured at the center) of each pellet are recorded. The pellets are then placed in the conditioning chamber and temperature cycled between -54 and 71°C (-65 and $+160^{\circ}\text{F}$) for 30 or more cycles. The test samples are maintained at each temperature long enough for the entire sample to reach equilibrium with the conditioning chamber. An additional pellet of the test explosive equipped with a thermocouple at its center may be used to track the internal temperature of the test samples.

5.2 At the conclusion of 30 or more cycles the pellets are slowly conditioned to $20 \pm 2^{\circ}\text{C}$ ($70 \pm 3^{\circ}\text{F}$) weighed and carefully measured to the nearest 0.01mm (0.0005 inches) using a micrometer or calipers. The final mass, length and diameter (measured at the center) of each pellet are recorded.

5.3 The change in volume (in percent of original volume) of each pellet is calculated using the measured dimensions. Alternatively, the change in volume may be determined by density change.

6. RESULTS AND DATA:

- 6.1 The following information shall be reported for this test:
- Method used to prepare the test samples (pressing, casting)
 - Type of conditioning chamber used to conduct the test (programmable, manual)
 - Initial sample mass, length, diameter and percent of theoretical maximum density (TMD) for each sample
 - Number of temperature cycles
 - Duration of conditioning of the samples at each temperature
 - Temperature profile; i.e., rate at which temperature was changed from maximum to minimum, dwell time at extreme temperatures, heating or cooling rate to return samples to 20°C
 - Percent volume change for each sample
 - Average percent volume change

MIL-STD-1751A

- i. Observations of change in appearance, e.g., cracking, discoloration, etc.

7. **SUPPLEMENTAL INFORMATION:** None.

8. **NATIONAL REFERENCES:** None.

STANDARDIZATION DOCUMENT IMPROVEMENT PROPOSAL

INSTRUCTIONS

1. The preparing activity must complete blocks 1, 2, 3, and 8. In block 1, both the document number and revision letter should be given.
2. The submitter of this form must complete blocks 4, 5, 6, and 7.
3. The preparing activity must provide a reply within 30 days from receipt of the form.

NOTE: This form may not be used to request copies of documents, nor to request waivers, or clarification of requirements on current contracts. Comments submitted on this form do not constitute or imply authorization to waive any portion of the referenced document(s) or to amend contractual requirements.

I RECOMMEND A CHANGE:	1. DOCUMENT NUMBER MIL-STD-1751A (OS)	2. DOCUMENT DATE (YYMMDD) 011211
3. DOCUMENT TITLE Safety and Performance Tests for The Qualification of Explosives (High Explosives, Propellants, and Pyrotechnics)		
4. NATURE OF CHANGE (<i>Identify paragraph number and include proposed rewrite, if possible. Attach extra sheets as needed.</i>)		
5. REASON FOR RECOMMENDATION		
6. SUBMITTER		
a. NAME (<i>Last, First, Middle Initial</i>)	b. ORGANIZATION	
c. ADDRESS (<i>Include Zip Code</i>)	d. TELEPHONE (<i>Include Area Code</i>) (1) Commercial (2) DSN (<i>If applicable</i>)	7. DATE SUBMITTED (YYMMDD)
8. PREPARING ACTIVITY		
a. NAME Commander, Indian Head Division Naval Surface Warfare Center	b. TELEPHONE (<i>Include Area Code</i>) (1) Commercial 301-744-4700 (2) DSN 354-4700	
c. ADDRESS (<i>Include Zip Code</i>) Engineering Documentation Branch (Code 4230) 101 Strauss Avenue Indian Head, MD 20640-5035	IF YOU DO NOT RECEIVE A REPLY WITHIN 45 DAYS, CONTACT: Defense Standardization Program Office (DLSC-LM) 8725 John J. Kingman Road, Suite 2533 Fort Belvoir, VA 22060-6221 Telephone (703) 767-6888 DSN 427-6888	