

**MIL-STD-1312 B**  
**19 OCTOBER 1984**

**SUPERSEDING**  
**DOD-STD-1312A**  
**26 March 1984**

# MILITARY STANDARD

FASTENER TEST METHODS



**FSC 53GP**

MIL-STD-1312B

DEPARTMENT OF DEFENSE  
Washington, DC 20301

FASTENER TEST METHODS

MIL-STD-1312B

1. This Military Standard is approved for use by all Departments and Agencies of the Department of Defense.

2. Beneficial comments (recommendations, additions, deletions) and any pertinent data which may be of use in improving this document should be addressed to: Commanding Officer, Naval Air Engineering Center, Systems Engineering and Standardization Department (SESD), Code 93, Lakehurst, NJ 08733, by using the self-addressed Standardization Document Improvement Proposal (DD Form 1426) appearing at the end of this document or by letter.

## MIL-STD-1312B

## FOREWORD

1. Background. The selection of fasteners in the design and construction phase of weapons systems and equipments and the analysis of fasteners used therein for parameters, such as suitability, standardization, and simplification requires the evaluation and correlation of test data and criteria. In evaluating these functions, it has become increasingly evident that the data and criteria received from prime contractors, fastener producers, private laboratories, military documents, and military laboratories cannot be adequately correlated. The chief reason for this is the absence of unified standards prescribing test methods, procedures, fixtures, data analysis, and data presentation. This disparity encourages and often requires duplication of testing and reduces reliability of weapons systems and equipments, thereby impairing operations involving engineering control, design maintenance, quality assurance, standardization, and logistics simplification. To correct this situation it was established that a unified set of test methods and procedures is required to serve as a basic engineering tool for obtaining and presenting engineering data. As a result, this document was developed and prepared to satisfy this vital need. This standard delineates standard test methods, procedures, conditions, fixtures, and methods of recording, analyzing and presenting test data. The purpose of the resulting test data is to determine the capability of fasteners to withstand the various environmental and mechanical conditions encountered when used in military weapons systems.

2. Benefits. Many benefits are to be expected by unified standard tests for fasteners. The following is a list of benefits that can be expected to accrue from using this standard.

a. Availability of testing techniques and criteria necessary for the design and development of increasingly superior structural fasteners. In the past, when a new fastener was needed to solve a problem, the necessary test procedures had to be developed and written; also, the necessary fixtures had to be designed. This always imposed delays, additional expenses, variations in test methods and in test results.

b. Increasing incidences of correlation among fastener test data and design engineering techniques and design criteria for weapons systems and equipments. As new systems are designed to achieve higher performance for a given volume and mass of material, it is essential that design data for structural joints (a large portion of which is obtained by testing fasteners) maintain a close correlation with engineering techniques and design criteria. Where weight is of importance, such as in aircraft structures, such close correlation will provide a substantial reduction in weight.

c. Availability of testing techniques and criteria necessary to maintain consistent quality in the procurement of fasteners.

## MIL-STD-1312B

d. Reduction in the time and effort required for the development of procurement specifications for fasteners by having a series of standard tests available.

e. Elimination of duplication in the development of test methods and documents by individual fastener producers, Government contractors, and military activities.

f. Elimination of duplication of effort in research and evaluation due to lack of unified standard test methods. When test methods are not standard, results cannot be correlated; therefore, producers, prime contractors, and military activities will not accept each other's results and will duplicate research, development, and evaluation work.

g. For logistics simplification, fastener attributes must be reduced to a common denominator so that variation in type can be compared. Data and the presentation thereof, by means of this standard, will be provided in such form that various types and variations in types of fasteners may be compared to determine their degree of interchangeability, substitutability, and replaceability.

h. Time and effort required to reach agreement in regard to specific engineering changes will be reduced by providing unified standard tests for use in evaluating new fasteners.

i. This standard will provide a means for establishing guidelines for evaluating fastener test data and engineering techniques.

j. Industry and Government design personnel will become thoroughly indoctrinated in the use of a single standard prescribing unified standard test methods.

## ACKNOWLEDGEMENT

This standard was prepared by the Fastener Testing Development Group (FTDG), consisting of representatives of Government agencies, engineering societies, trade associations, independent testing laboratories, the using industry, and the fastener producing industries.

With the increased implementation of the International System of Units (SI) or metric system in military specifications and standards, the Department of Defense (DoD) has approved its usage in this standard. Therefore, this issue, prepared under DoD Project Number 53GP-0142-20 by the FTDG, includes test methods in the SI and inch-pound (I-P) units.

## MIL-STD-1312B

## TABLE OF CONTENTS

<u>Paragraph</u>		<u>Page</u>
1.	SCOPE .....	1
1.1	Applicability .....	1
2.	REFERENCED DOCUMENTS .....	1
2.1	Government documents .....	1
2.1.1	Specifications, standards and handbooks .....	1
3.	DEFINITIONS .....	1
4.	GENERAL REQUIREMENTS .....	1
4.1	Test method numbering system .....	1
4.2	Document format structure .....	2
4.3	Method of revision .....	2
4.3.1	Revision to test method number .....	3
4.4	Selection of tests .....	3
4.5	Method of reference .....	3
5.	DETAIL REQUIREMENTS .....	4

## APPENDICES

<u>Appendix</u>		<u>Page</u>
A	List of Available Test Methods in Inch-Pound (I-P) Units .....	5
B	List of Available Test Methods in International System (SI) Units .....	6
C	Alignment and Load Verification of Axial-Load Fatigue Testing Machines .....	7

## 1. SCOPE

1.1 Applicability. This standard establishes methods for testing fasteners, covering both the SI and I-P units, to determine their physical and mechanical properties. These standard test methods will yield reproducible data for use in research, development, procurement or product application. These test methods shall be observed when specifically referenced in the applicable documents. In case of conflict between the provisions of these methods and the individual test procedure in the specification for a particular item, the latter shall take precedence. This document exists as a dynamic standard subject to addition and change as reflected by the "state-of-the-art."

## 2. REFERENCED DOCUMENTS

2.1 Government documents.

2.1.1 Specifications, standards and handbooks. Unless otherwise specified, the following specifications, standards and handbooks of the issue listed in the current Department of Defense Index of Specifications and Standards (DoDISS) and the supplement thereto (if applicable), form a part of this standard to the extent specified herein.

## STANDARDS

## MILITARY

MIL-STD-962                      Outline of Forms and Instructions for the Preparation of Military Standards and Military Handbooks

2.1.2                      Documents applicable to a particular test method bookform standard part or section shall be listed therein.

(Copies of specifications, standards, handbooks, drawings, and publications required by contractors in connection with specific acquisition functions should be obtained from the contracting activity or as directed by the contracting officer.)

## 3. DEFINITIONS

3.1                      SI - The International System of Units (from the French "Le Systeme International d'Unites"), as modified for use in the United States by the Secretary of Commerce.

Inch-pound units - Units based upon the yard and the pound commonly used in the United States of America and defined by the National Bureau of Standards. Note that units having the same names in other countries may differ in magnitude.

3.2                      Definitions applicable to a particular test method bookform standard part or section shall be listed therein.

## 4. GENERAL REQUIREMENTS

4.1 Test method numbering system. This standard consists of a general basic document and supporting parts or sections. Each part addresses a specific test method which is designated by a dash number commencing with number 1 for the I-P system of measurement and number 101 for the SI system of measurement. A different dash number is assigned to each test method.

4.2 Document format structure. Each test method is prepared as an individual document in the format of a bookform standard in accordance with the guidelines of MIL-STD-962. The individual bookform standard part is identified by the basic document identifier, MIL-STD-1312 for the I-P system of measurement and DOD-STD-1312 for the SI system of measurement, followed by a sequential dash number. The dash number is identical to the number of the test method. Examples:

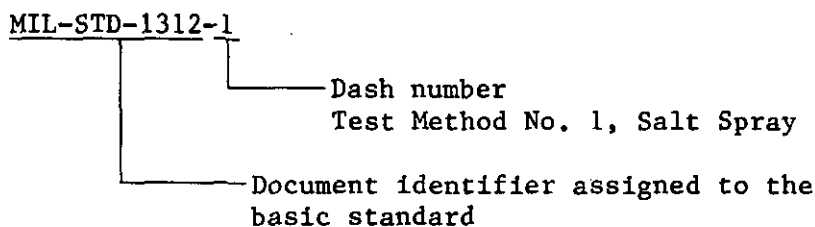
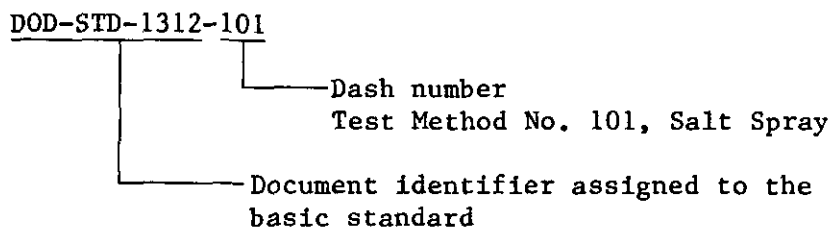
I-P SystemSI System

4.3 Method of revision. The individual bookform standard part is revised and issued independent of the other parts. Revisions are identified by a capital Gothic letter immediately following the document identifier dash number. Examples:

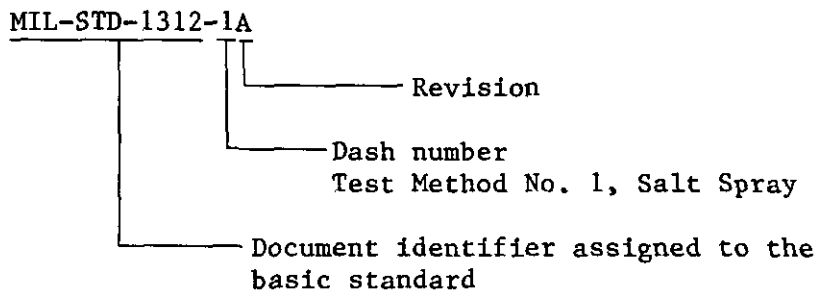
I-P System

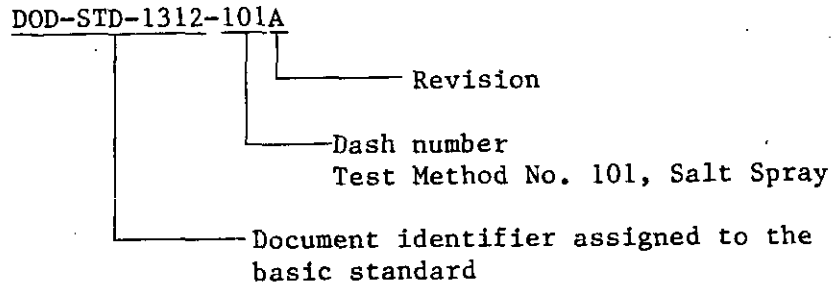
SI System

Changes to individual pages shall be accomplished in accordance with the change notice guidelines of MIL-STD-962.

4.3.1 Revision to method number. Revision to the document will also reflect a change to the test method number. The revision to the test method shall be denoted by a letter following the original number. For example: The original test method number assigned "Test Method 1, Salt Spray" shall be changed to "Test Method 1A, Salt Spray" or "Test Method 101, Salt Spray" shall be changed to "Test Method 101A, Salt Spray" when revised.

4.4 Selection of tests. The tests contained herein are intended to be used to provide uniform testing methods and presentation of data for fasteners and fastening. These tests shall be applicable for research, development and procurement of weapons systems, equipments, and fasteners. In selecting the tests that are to be applicable to fasteners in a specific category or type, it is required that those fastener properties be determined that are needed for incorporation of specific fasteners in specific types of weapons systems and equipments and those properties that are essential for fabrication of a satisfactory fastener. After these essential properties have been determined, the appropriate test shall be selected and specified for each property. Care shall be taken to specify only those tests that are needed.

4.4.1 The test methods available for reference and selection are outlined in the following Appendices:

- a. APPENDIX A - List of available test methods in the I-P system of measurement.
- b. APPENDIX B - List of available test methods in the SI system of measurement.

4.5 Method of reference. This standard shall be referenced in general and detailed specifications or other documentation for military weapons systems. Tests shall be referenced in the individual fastener specification, fastener specification control drawing, etc., by specifying:

MIL-STD-1312B

- a. The standard number with the applicable dash number but without the revision letter. For example: "the fastener shall be tested for stress durability in accordance with MIL-STD-1312-5."
- b. Test criteria or property values required.

5. DETAIL REQUIREMENTS

5.1 Detail requirements shall be incorporated in the individual test method bookform standard part or section.

Custodians:

Army - AR  
Navy - AS  
Air Force - 11

Preparing activity:

Navy - AS  
(Project No. 53GP-0152)

Reviewer activities:

Army - AV, AR  
Navy - AS, SH  
Air Force - 11  
DLA - IS

## APPENDIX A

LIST OF AVAILABLE TEST METHODS  
IN I-P SYSTEM OF MEASUREMENT

10. Test methods. The following test methods in the I-P system are available for selection and reference:

MIL-STD-1312-1	Salt Spray
MIL-STD-1312-2	Interaction
MIL-STD-1312-3	Humidity
MIL-STD-1312-4	Lap Joint Shear
MIL-STD-1312-5	Stress Durability
MIL-STD-1312-6	Hardness
MIL-STD-1312-7	Vibration
MIL-STD-1312-8	Tensile Strength
MIL-STD-1312-9	Stress Corrosion
MIL-STD-1312-10	Stress Rupture
MIL-STD-1312-11	Tension Fatigue
MIL-STD-1312-12	Thickness of Metallic Coatings
MIL-STD-1312-13	Double Shear
MIL-STD-1312-14	Stress Durability (Internally Threaded Fasteners)
MIL-STD-1312-15	Torque-Tension
MIL-STD-1312-16	Clamping Force for Installation Formed Fasteners
MIL-STD-1312-17	Stress Relaxation
MIL-STD-1312-18	Elevated Temperature Tensile Strength
MIL-STD-1312-19	Fastener Sealing
MIL-STD-1312-20	Single Shear
MIL-STD-1312-21	Shear Joint Fatigue, Constant Amplitude
MIL-STD-1312-22	Receptacle Push-out, Panel Fasteners
MIL-STD-1312-23	Tensile Strength of Panel Fasteners
MIL-STD-1312-24	Receptacle Torque-out, Panel Fasteners
MIL-STD-1312-25	Driving Recess Torque (Quality Conformance Test)
MIL-STD-1312-26	Structural Panel Fastener Lap Joint Shear
MIL-STD-1312-27	Panel Fastener Sheet Pull-up
MIL-STD-1312-28	Elevated Temperature Double Shear
MIL-STD-1312-29	Shank Expanding
MIL-STD-1312-30	Sheet Pull-up of Blind Fasteners

## APPENDIX B

LIST OF AVAILABLE TEST METHODS  
IN SI SYSTEM OF MEASUREMENT

10. Test methods. The following test methods in the SI system are available for selection and reference.

DOD-STD-1312-105	Stress Durability
DOD-STD-1312-107	Vibration
DOD-STD-1312-108	Tensile Strength
DOD-STD-1312-109	Stress Corrosion
DOD-STD-1312-111	Tension Fatigue
DOD-STD-1312-113	Double Shear

## MIL-STD-1312B

## APPENDIX C

ALIGNMENT AND LOAD VERIFICATION OF  
AXIAL-LOAD FATIGUE TESTING MACHINES

## 10. SCOPE

- 10.1 This procedure covers the techniques and equipment to be used to verify proper machine and fixture alignment and cyclic-load application for axial-load fatigue testing machines. Examples of typical fixtures are included.
- 10.2 General Procedure. The general procedure for alignment and load verification of axial-load fatigue testing machines consists of the following steps:
- a. Select proper equipment for static alignment.
  - b. Check calibration of equipment.
  - c. Check machine alignment and make adjustments as required.
  - d. Select proper equipment for dynamic load verification and install in test machine.
  - e. Apply static loads and verify.
  - f. Operate machine dynamically, record indicated loads, and compute amplitude and maximum load errors.

## 20. APPLICABLE DOCUMENTS

MIL-S-8879	Screw Threads, Controlled Radius Root with Increased Minor Diameter, General Specification for
MIL-C-15074	Corrosion Preventive, Fingerprint Remover
AMS 6280	Steel Bars, Forgings, and Rings, 0.50 Cr 0.55 Ni 0.20 Mo (0.28-0.33 C) (SAE 8630)
AMS 6304	Steel Bars, Forgings, and Tubing, Low Alloy Heat Resistant 0.95 Cr - 0.55 Mo - 0.3V (0.40-0.50 C)
AMS 6485	Steel, 5 Cr - 1.3 Mo - 0.5V (0.38-0.43 C)
AMS 6487	Steel Bars and Forgings, 5 Cr - 1.3 Mo - 0.5V (0.38-0.43 C) Premium Quality, Consumable Electrode Vacuum Melted
ASTM E4	Verification of Testing Machines

## MIL-STD-1312B

ASTM E74	Verification of Calibration, Devices for Verifying Testing Machines
ANSI B46.1	Surface Texture (Surface Roughness, Waviness, and Lay)

## 30. SIGNIFICANCE OF ALIGNMENT AND DYNAMIC VERIFICATION

- 30.1 While it is relatively easy to measure the forces applied to a specimen under static condition, it is essential to ensure that excessive bending loads are not induced and to verify that the amplitude of the dynamic forces applied to the specimen agrees with the amplitude of the indicated loads within acceptable limits.
- 30.2 The presence of unknown and undesirable bending loads induced through fatigue machine and/or fixture misalignment may severely reduce the fatigue life of test specimens and, hence, must be controlled within reasonable limits.
- 30.3 The accuracy of the indicated loads may be dependent upon several factors which include:
- Configuration of the specimen, including dimensions.
  - Configuration of the testing machine fixtures and specimen adapters.
  - Specimen material properties, including density, static and dynamic stress-strain characteristics, and material damping coefficient.
  - Load settings of the testing machine controls.
  - The waveform of the load cycle.
  - The frequency of the load cycle.
- 30.4 Ideally, the loads applied to a specimen in a fatigue test should be verified for each combination of the above factors. It is recognized, however, that within certain limits of variation, the effects of an individual factor on the loads may be small or reasonably predictable.

## 40. DEFINITIONS

- 40.1 Fatigue-testing machine. A device for applying repeated load cycles to a specimen.
- 40.2 Load. The force applied to the specimen. In the case of fatigue-testing machines, load is usually measured in units of pound-force or newtons.

- 40.3 Load cycle. The smallest segment of the load-time function which is repeated periodically.
- 40.4 Maximum load. The load having the highest algebraic value in the load cycle, tensile load being considered positive and compressive load being considered negative.
- 40.5 Minimum load. The load having the lowest algebraic value in the load cycle, tensile load being considered positive and compressive load being considered negative.
- 40.6 Mean load. The algebraic average of the maximum and minimum loads in the load cycle.
- 40.7 Load amplitude. One half of the algebraic difference between the maximum and minimum loads in the load cycle.
- 40.8 Set loads. The maximum and minimum loads (or the mean load and the load amplitude) that relate to the settings and adjustments of the controls of a fatigue-testing machine, according to an existing set of guidelines. These guidelines may have been furnished by the manufacturer of the machine or they may have been developed by the user.
- 40.9 Indicated loads. The maximum and minimum loads (or the mean load and the load amplitude) that relate to the readings obtained from the indicating or recording equipment associated with the fatigue testing machine, according to an existing calibration. This calibration may have been furnished by the manufacturer of the machine, or may have been developed by the user. In the case of fatigue-testing machines having no provision for load readout, the indicated loads shall be determined by introducing an appropriate sized dynamometer into the load chain.
- 40.10 Dynamometer. An elastic calibration device for use in verifying the indicated loads applied by a fatigue testing machine. It shall consist of an instrumented member having mass, stiffness, and end displacements such that the inertial effects of the specimen and its attachments to the test machine, for which the verification of loads is desired, are duplicated as nearly as is reasonable. The instrumentation shall permit an accurate determination of the magnitude of the average strain, in a region of uniform transverse cross section, when the dynamometer is subjected to a tensile or compressive force along its longitudinal axis.
- 40.11 Dynamometer range. The range of loads for which the dynamometer may be used for verification purposes. A dynamometer for use in tension and in compression will have two dynamometer ranges, one in tension and one in compression.

## MIL-STD-1312B

- 40.12 Alignment cell. An elastic device, normally cylindrical in cross section, with strain gages affixed to the outer surface so as to provide indications of axial strain at 90 degree intervals around the circumference. Comparison of strain readings at a constant load provides a measure of bending induced by the loading system.

## 50. FATIGUE TEST MACHINES

- 50.1 Load measuring system. The dynamic load measuring system shall be accurate within  $\pm 2$  percent of the indicated maximum load and amplitude, for loads greater than 10 percent of the maximum capacity of the dynamometer.
- 50.2 Loading maintaining system. The load maintaining system shall be capable of maintaining the required load within  $\pm 2$  percent. Machines operating without load maintainers shall be monitored at intervals by the operator. The intervals shall be determined according to the expected cycle life and equipment capability.
- 50.3 Static alignment. Static alignment of each fatigue test machine shall be verified at any time necessary to ensure meeting the alignment requirements of this appendix. Alignment check may be accomplished by mechanical or strain gaged alignment cell systems. The method employed (see Section 7) shall be capable of proving that the stress caused by misalignment (eccentric loading) shall not exceed 6 percent of the average stress.
- 50.4 Dynamic load verification. The load accuracy of each machine shall be verified after each 1000 hours of operating time or every 6 months, whichever occurs first, and after any machine modification which could affect the load accuracy. The verification procedure shall be in accordance with Section 8.

## 60. EQUIPMENT AND CALIBRATION OF ALIGNMENT AND DYNAMIC LOAD VERIFICATION EQUIPMENT

- 60.1 General. A dynamometer of any suitable configuration and material may be used. The dynamometer should normally have dimensions such that a strain in the range from 0.0012 to 0.0015 in./in. is obtained at the maximum load of the dynamometer range. The dynamometer shall have a length of uniform cross section for attachment of the transducer (see Figure 1).
- a. The verification procedure consists of the following principal steps:

1. Obtain the static load - strain (or a quantity proportional to strain) relationship for the dynamometer using a static testing machine or dead weights.

NOTE 1: Whenever the term "strain" is used in this recommended practice, it is understood that any quantity proportional to strain is acceptable.

2. Measure the strains in the dynamometer during cyclic loading at each of the desired maximum and minimum loads and test frequencies in the fatigue testing machine.
3. Convert the measured strains or appropriate instrumentation readings to loads using the static load-strain relationship. This approach assumes that the load strain relationship for the dynamometer is the same under cyclic loading as it is under static loading. The extent to which this assumption is justified is not known precisely at this time.

60.2 Strain transducer. The dynamometer shall be instrumented with a transducer in such a way as to permit a determination of the average strain in the uniform section of the dynamometer and determination of the amount or percent of bending applied to the dynamometer when it is subjected to an axial load. The transducer shall be sensitive to force changes of 0.2 percent of the maximum load of the dynamometer range.

- a. One acceptable transducer consists of not less than four nominally identical electrical resistance strain gages mounted longitudinally on the uniform section of the dynamometer, at points equally distributed around the section and equidistant from the ends of the section. Provision shall be made for recording the strain sensed by each gage individually for evaluating the amount of bending in the dynamometer. For determination of average strains, provision shall be made for connecting diametrically opposed gages in series, each pair in opposite arms of a Wheatstone bridge. In the other two arms of the bridge, four gages identical to the four gages above shall be mounted transversely on the dynamometer and connected in pairs so as to provide temperature compensation (see Figure 2).

NOTE 2: The use of 90-degree rosette gages is acceptable.

NOTE 3: Transducers for use on electromagnetic systems should be made from nonmagnetic materials such as titanium.

- 60.3 Measurement of static strains. The instrumentation used to record the static strains shall be the same as that to be used to record the dynamic strains.
- a. To achieve high resolution and accuracy, a null-reading method may be employed in which the output from the transducer can be adjusted to be zero at any particular load. It is then necessary only to detect zero output of the transducer at any load. When using the electrical resistance strain gage transducer, a convenient method is to have the strain gages in the adjustable bridge circuit fed from a direct current (dc) supply and to observe the output on an oscilloscope which is switched rapidly between the bridge output and ground. When the switching produces no change, the bridge is in balance and the adjustment made to produce a balance relates to the applied load. The oscilloscope must be sensitive to load changes of 0.2 percent of maximum load when the strain gage bridge is in a nearly balanced condition. It is necessary to ensure that the output of the bridge circuit and any amplifier between the bridge and the oscilloscope is linear with amplitude and independent of frequency throughout the frequency range over which the force will be cycled (see Figure 3 for typical equipment).
  - b. If a null method is not used, the oscilloscope used must be capable of measuring loads with an accuracy of 0.2 percent of the maximum load. Use of a pen-type recorder is discouraged due to the inertia of the writing pen; however, light beam oscillographs are acceptable.
  - c. A preferred method is to use a dual-channel oscilloscope where one channel records the output of the bridge and the other channel is grounded. The bridge is then balanced when the null is observed, that is, the two signals are coincident.
- 60.4 Static calibration. The dynamometer shall be statically calibrated using dead weights, a static testing machine, or a fatigue machine using a loading range that complies with ASTM E4. Calibration of the dynamometer is to be performed at a minimum of five loads, consisting of a low load not lower than 10 percent of the dynamometer range, the highest load of the dynamometer range, and a minimum of three additional loads spaced at approximately equal intervals through the dynamometer range. The dynamometer shall be mounted in the testing machine in such a way as to minimize bending. The sequence for the calibration procedure is as follows:

- a. Connect the associated instrumentation, such as the adjustable bridge circuit power supply, amplifier, and oscilloscope, etc., to the dynamometer transducer and, after switching on, allow the requisite period for stabilization.
- b. Minimize bending by mounting the dynamometer in such a way that the strain measured by any one of the measuring elements of the transducer attached to the dynamometer does not differ by more than 6 percent from the average of the strain measured by all the elements at any load in the dynamometer range. Measure output for zero load with only one end of the dynamometer gripped in the testing machine.
- c. Prior to static calibration, apply and remove loads at least three times from zero load to the maximum load of the dynamometer range. The change in axial strain recorded after a period of not less than 1 minute at the minimum load, on consecutive readings, shall not exceed  $\pm 0.2$  percent of the axial strain at the maximum load.
- d. Apply static loads in not less than five approximately equal increments up to the maximum of the dynamometer range. At each increment, simultaneously record the transducer strain readings and load.
- e. Unload the dynamometer in not less than five approximately equal increments to zero load. At each increment, simultaneously record the transducer strain readings and load.
- f. Repeat operations c, d and e twice to obtain three series of calibration readings. Between each two series of readings, rotate the dynamometer approximately 30 degrees to facilitate the detection of maximum bending. Between the second and third series of readings disconnect the associated transducer instrumentation and remove the dynamometer from the testing machine, and then remount it as above. The average strain measured during any one series shall not differ by more than 1 percent from the average strain of all three series.
- g. Obtain the static calibration of the dynamometer from the mean of the three series of transducer and indicated loads of the static or fatigue testing machine or dead weights. The relationship between load and strain should be essentially linear.

## 70. PROCEDURE FOR STATIC ALIGNMENT

- 70.1 Equipment. Equipment described in Section 6 may be used for static alignment and dynamic load verification, as applicable.

- a. Strain gaged dynamometers (load cells) of appropriate size may be used for alignment adjustment (Figures 3a and 4).
- b. A bridge amplifier (or equivalent) is used to condition and amplify the load (strain) signal (Figure 3b).
- c. A multichannel switch and balance is used for strain gage element selection and basis signal balance (Figure 3c).
- d. A high quality oscilloscope or light beam galvanometer recording device is used to display the load (strain) signal.

70.2 Alignment cells. Static alignment cells should be designed to operate between 15 and 60 ksi at the verification load. The verification load shall be at least 10 percent of the maximum machine capacity. Typical alignment cells, the material from which they were made, and verification loads that cover maximum machine capacities from 440 pounds to 250,000 pounds are shown in Figure 4. Tubular cells or actual test bolts of appropriate load range may be used.

70.3 Procedure. Four strain gages shall be bonded 90 degrees apart around the circumference on a common plane perpendicular to the axis of the cell. Each active strain gage shall be wired into a separate channel of the switch and balance unit so it can be individually balanced and switched into the strain indicator.

70.4 Alignment example.

- a. To check the alignment on a 24,000 pound fatigue machine, take 10 percent of 24,000 = 2400 pounds. From Figure 4 select cell no. 7, rated for use between 2400 and 9600 pounds.
- b. Assemble the alignment cell into the test machine using equipment that meets the specified fixture requirements.
- c. Load the alignment cell to 2400 pounds and record the strain in order from gages 1, 2, 3 and 4. Unload the machine, and rotate the alignment cell 45 degrees; load the cell again to 2400 pounds and record the readings from gages 1, 2, 3 and 4.
- d. Sample calculations of strain gage results from the 2400 pound test loadings;

Strain readings from

Parameter	<u>Gage 1</u>	<u>Gage 2</u>	<u>Gage 3</u>	<u>Gage 4</u>	
2400 lb load	573	570	604	603	Mean strain = 587
Minus mean	<u>587</u>	<u>587</u>	<u>587</u>	<u>587</u>	
Difference	14	17	17	16	

Average difference of gages 1 plus 3 from mean:  $\frac{14 + 17}{2} = 15.5$

Average difference of gages 2 plus 4 from mean:  $\frac{17 + 16}{2} = 16.5$

Maximum value from mean =  $\sqrt{15.5^2 + 16.5^2} = 22.64$

Percent bending =  $\frac{\text{Maximum value from mean} \times 100}{\text{MEAN}} = \frac{2264}{587} = 3.86\%$

Rotate Alignment Cell 45 Degrees:

Strain readings from

Parameter	<u>Gage 1</u>	<u>Gage 2</u>	<u>Gage 3</u>	<u>Gage 4</u>	
2400 lb load	610	609	580	578	Mean strain = 594.3

Calculate as above for percent bending = 3.62%

Average bending =  $\frac{3.86 + 3.62}{2} = 3.75\%$ ; i.e., less than 6%

80. PROCEDURE FOR DYNAMIC VERIFICATION OF FATIGUE MACHINES

80.1 General. Dynamic verification of the fatigue machine is required over the entire load range and frequency range where fatigue information is desired for each type of specimen to be tested. The overall verification consists of procedures covering both static alignment and dynamic operating conditions.

80.2 Measurement of dynamic strains. The instrumentation used to record the dynamic output of the transducer shall be the same as that used to record the static strains. Using the null-balance method, adjust the bridge so that the peak of the load signal is tangent to the ground trace on the oscilloscope when the signal is switched rapidly between the dynamometer and ground. When using the dual beam oscilloscope, adjust the bridge so that the peak of the strain signal is tangent to the ground signal and the adjustment to achieve a tangent relative to the applied dynamic load.

80.3 Procedure. For the verification of each minimum load and maximum load at each test frequency desired, adopt the following procedure:

- a. Mount the dynamometer in the fatigue machine, connect the associated transducer instrumentation and allow sufficient time for stabilization of all instruments.
- b. Ensure that the strain measured by any one of the measuring elements of the transducer attached to the dynamometer does not differ by more than 6 percent from the average of the strain measured by all of the elements at any load in the dynamometer range.
- c. Apply the desired minimum load statically and record the strain output of the transducer. Increase the load statically to the desired maximum and again record the transducer strain output.
- d. Operate the machine dynamically and adjust the machine controls to the programmed load level and frequency. Record the actual minimum and maximum operating strains from the transducer output.
- e. Compute the machine error as a percent of cyclic amplitude and maximum load as follows:

Static Comparison				Dynamic Comparison			
Machine Programmed Load - Lb		Dynamometer Indicated Strain Microinches		Machine Programmed Load - Lb		Dynamometer Indicated Strain Microinches	
<u>Min</u>	<u>Max</u>	<u>Min</u>	<u>Max</u>	<u>Min</u>	<u>Max</u>	<u>Min</u>	<u>Max</u>
300	3000	18	187	300	3000	19	185

Amplitude Error:

$$\frac{(185-19) - (187-18)}{(187-18)} \times 100 = 1.77\%$$

Maximum Load Error:

$$\frac{185-187}{187} \times 100 = -1.07\%$$

- f. With the instrumentation stabilized (for example, bridge balanced) at the maximum output level of one element of the transducer, stop the cyclic load. After a period of not less than 5 minutes, restart the cyclic load, observing the output of the transducer during the first cycle. Estimate the time interval before the output stabilizes at the steady state cyclic level.

NOTE 4: This indicates the magnitude of any start-up load transients which may have effects on the fatigue life of specimens tested in the machine.

- g. Repeat step f for each condition of maximum output level and frequency.

80.4 Note that changes in the ambient temperature of the room in which the verification is being carried out will adversely affect the precision of the measurements. The room temperature shall not change more than 5°F (2.8°C) during the verification.

90. REPORT.

80.1 The report shall contain the following:

a. Description of equipment:

1. Serial numbers and names of the manufacturers of all equipment used, including the fatigue-testing machine, the static-testing machine, the transducer, and each item of associated transducer instrumentation.
2. The information contained in the verification certificate for the static testing machine.
3. Complete, detailed description of the dynamometer.

b. For the static dynamometer calibration:

1. Method of mounting the dynamometer in the testing machine.
2. Complete record of the load and strain in the dynamometer calibration test and date performed.
3. Strain transducer excitation including chopper or carrier frequency, if applicable.

c. For each dynamic verification test condition:

1. Strain transducer excitation including chopper or carrier frequency, if applicable.
2. The load and the frequency settings.
3. The shape of the waveform.
4. Load and strain readings from the dynamometer readout equipment.

5. Load readings from the readout equipment associated with the fatigue testing machine, if any.
  6. The estimated value of the maximum startup overshoot or undershoot at each dynamic condition and the time to reach a steady state cyclic condition.
  7. The date of calibration.
100. FIXTURES. Standard fixturing has been developed for various types of fatigue machines (resonant, spring/mass, servo-hydraulic, direct-stress, etc.). Examples of typical fixtures are included for reference only.
- 100.1 Hole details. Head-to-shank fillet clearances, countersink head details, spacers, and adapters are shown in Figure 5.
- 100.2 Threaded fasteners.
- a. Example fixtures for use with threaded fasteners in spring/mass, servo-hydraulic and direct stress machines are shown in Figures 6 through 12.
  - b. Example fixtures for use with threaded fasteners in Amsler resonant frequency machines are shown in Figures 13 through 15.
- 100.3 Installation formed fasteners.
- a. Example fixtures for use with installation formed fasteners in spring/mass, servo-hydraulic and direct stress machines are shown in Figures 16 through 18.
  - b. Example fixtures for use with installation formed fasteners in Amsler resonant frequency machines are shown in Figures 19 and 20.

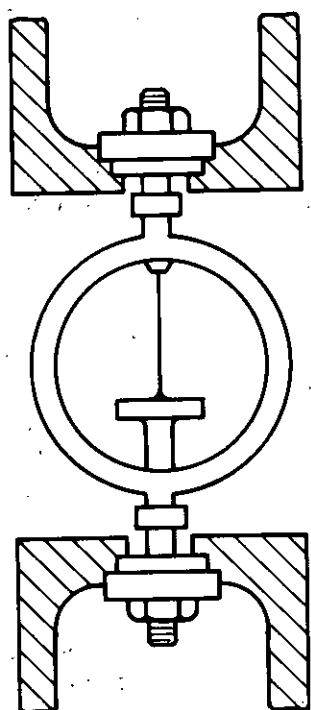

RING TYPE

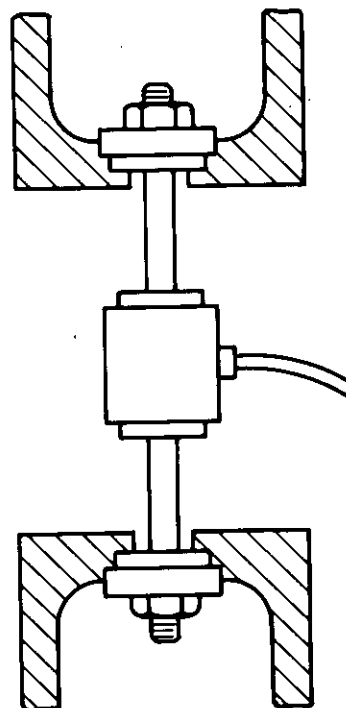

STRAIN GAGE TYPE

FIGURE 1. Elastic calibration devices.

MIL-STD-1312B

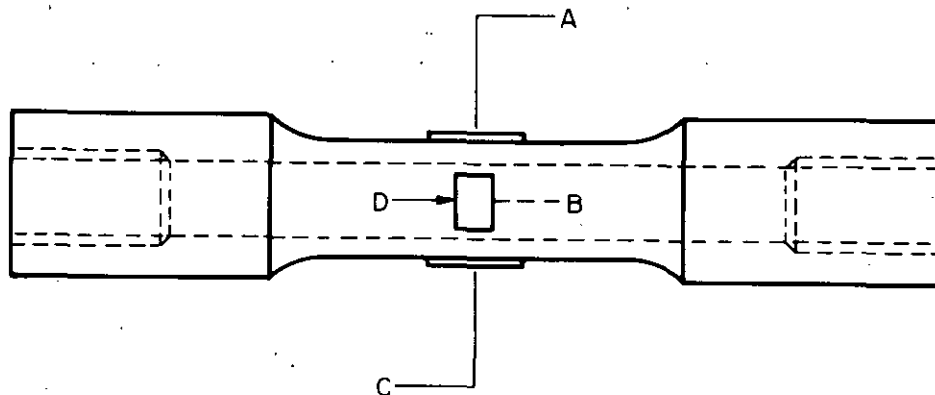

(A) LOAD CELL

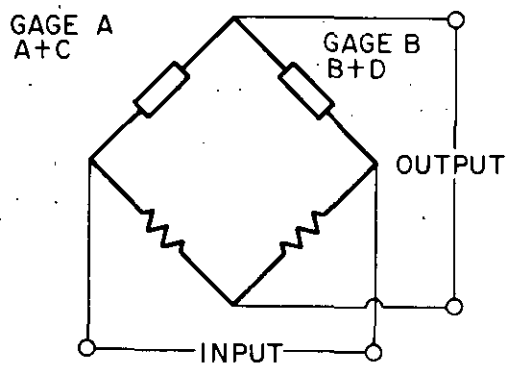

(B) HALF BRIDGE

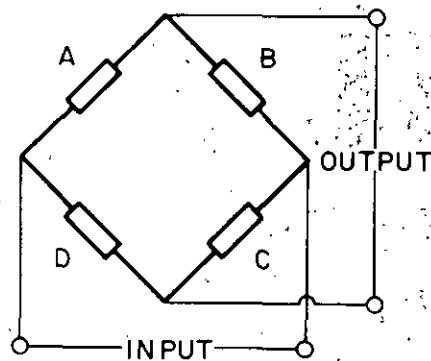

(C) FULL BRIDGE

FIGURE 2. Typical load cell circuits.

MIL-STD-1312B

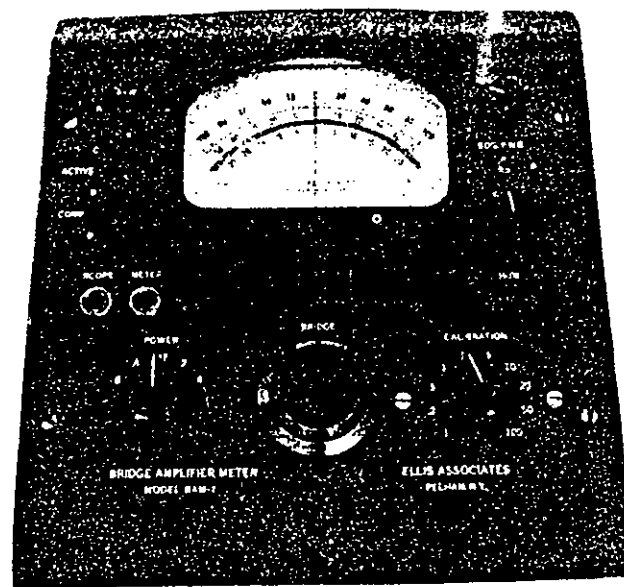
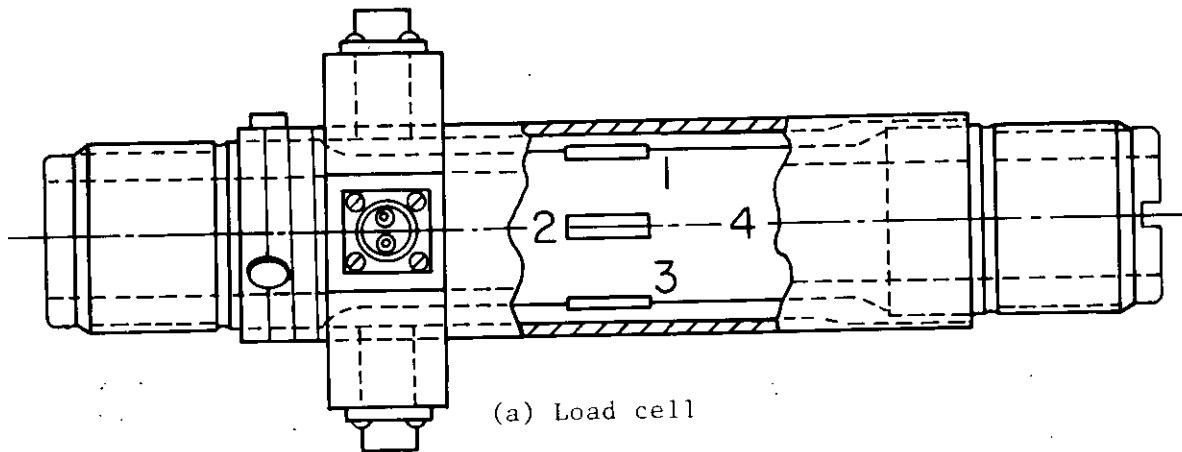
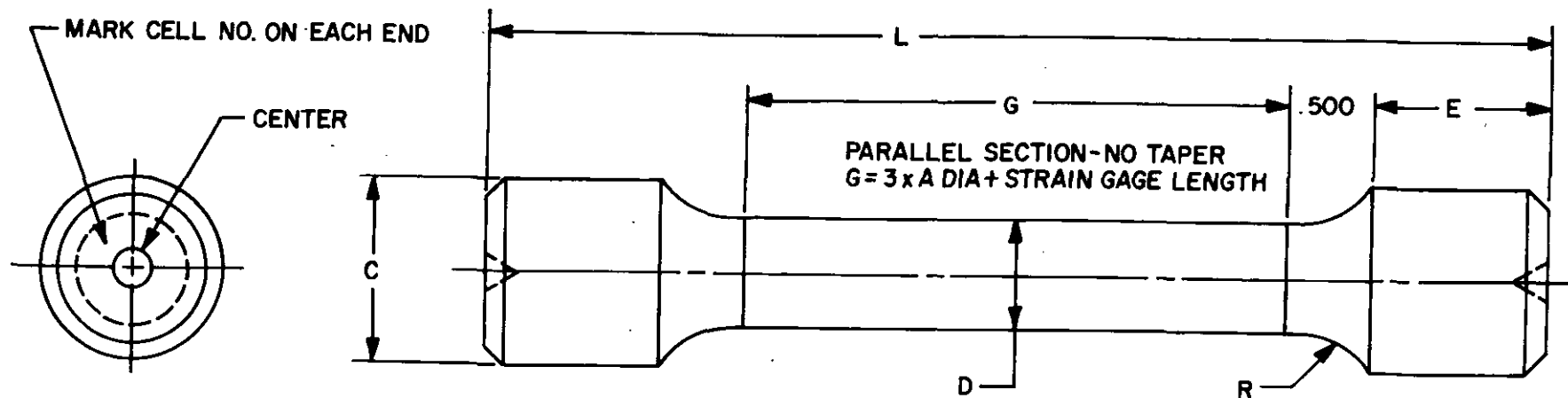

FIGURE 3. Typical equipment used for checking alignment and dynamic load verification.



Cell	D $\pm .001$	G $\pm .005$	C Class 3A	L Ref	E Note 1	+ .000 R - .100	Area Sq. In.	Minimum Load-Lbs (Based on 15 Ksi)	Maximum Load-Lbs (Based on 60 Ksi)
1	1.366	5.000	1.5000-12	10	2.000	.500	1.466	21,990	87,960
2	1.129	3.900	1.5000-12	10	2.500		1.000	15,000	60,000
3	1.050	3.650	1.5000-12	10	2.675		.866	12,990	51,960
4	.714	2.650	1.0000-14	7	1.675		.400	6,000	24,000
5	.652	2.500	1.0000-14	7	1.750		.333	5,000	20,000
6	.552	2.156	1.0000-14	7	1.900		.240	3,600	14,400
7	.452	1.860	1.0000-14	7	2.000		.160	2,400	9,600
8	.375	1.570	.7500-16	5.5	1.465		.100	1,500	6,000
9	.204	1.220	.7500-16	5.5	1.640	.500	.0326	489	1,960

## NOTES:

1. Blend thread into radius R.
2. All cylindrical surfaces to be ground on common center
3. Thread to be ground per Note 2.
4. Material: Alloy steel 36 HRC minimum.

FIGURE 4. Typical alignment cells.

## MIL-STD-1312B

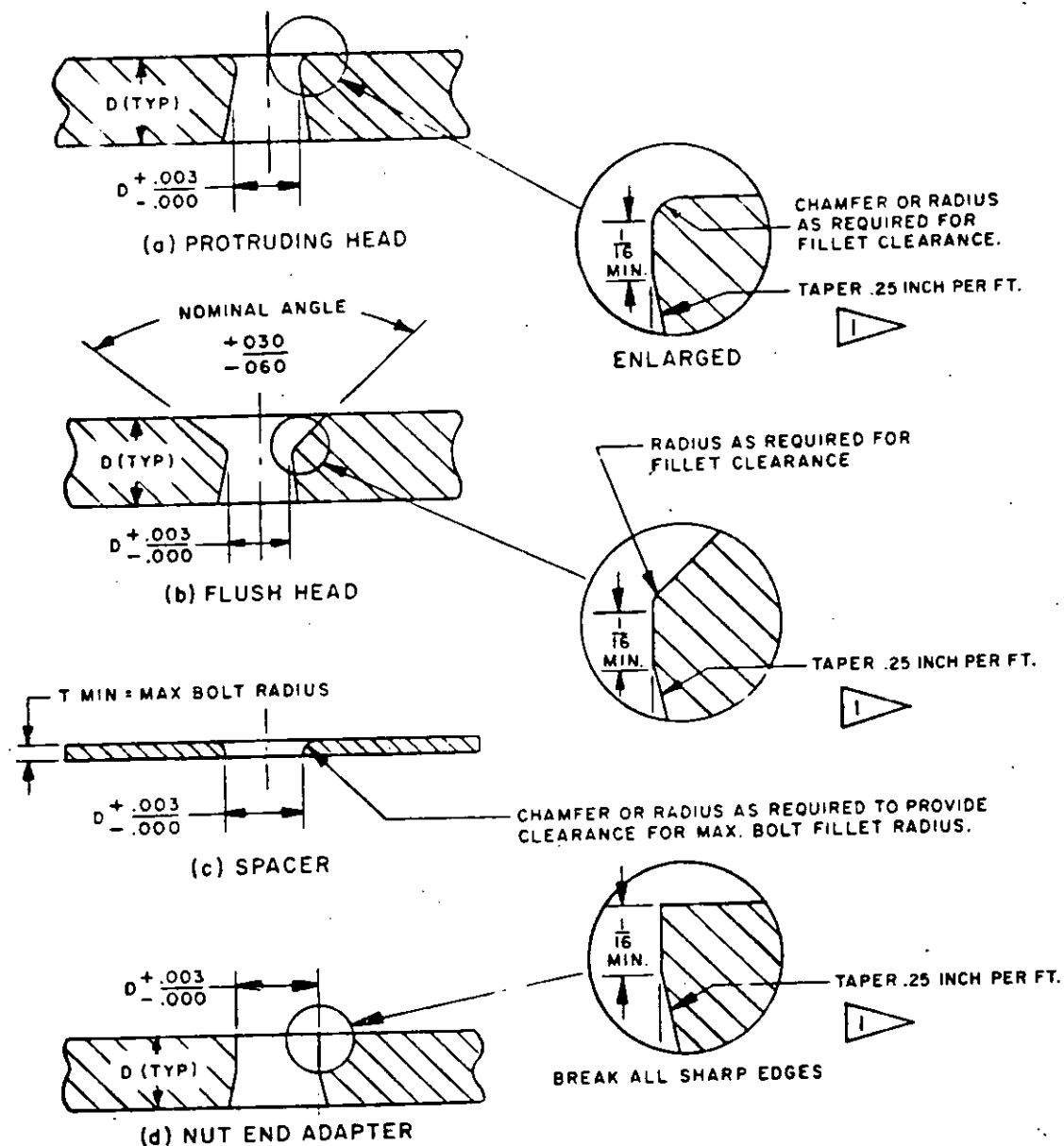

## NOTES:

1. Material: Steel, HRC 43 minimum.
2. Clean as required to maintain 32 microinch finish and required tolerances on load bearing surfaces.
3. All diameters to be square and concentric within .001" FIM.
4. Unless otherwise specified, dimensions in inches.

1 Taper Optional

FIGURE 5. Loading cups.

## MIL-STD-1312B

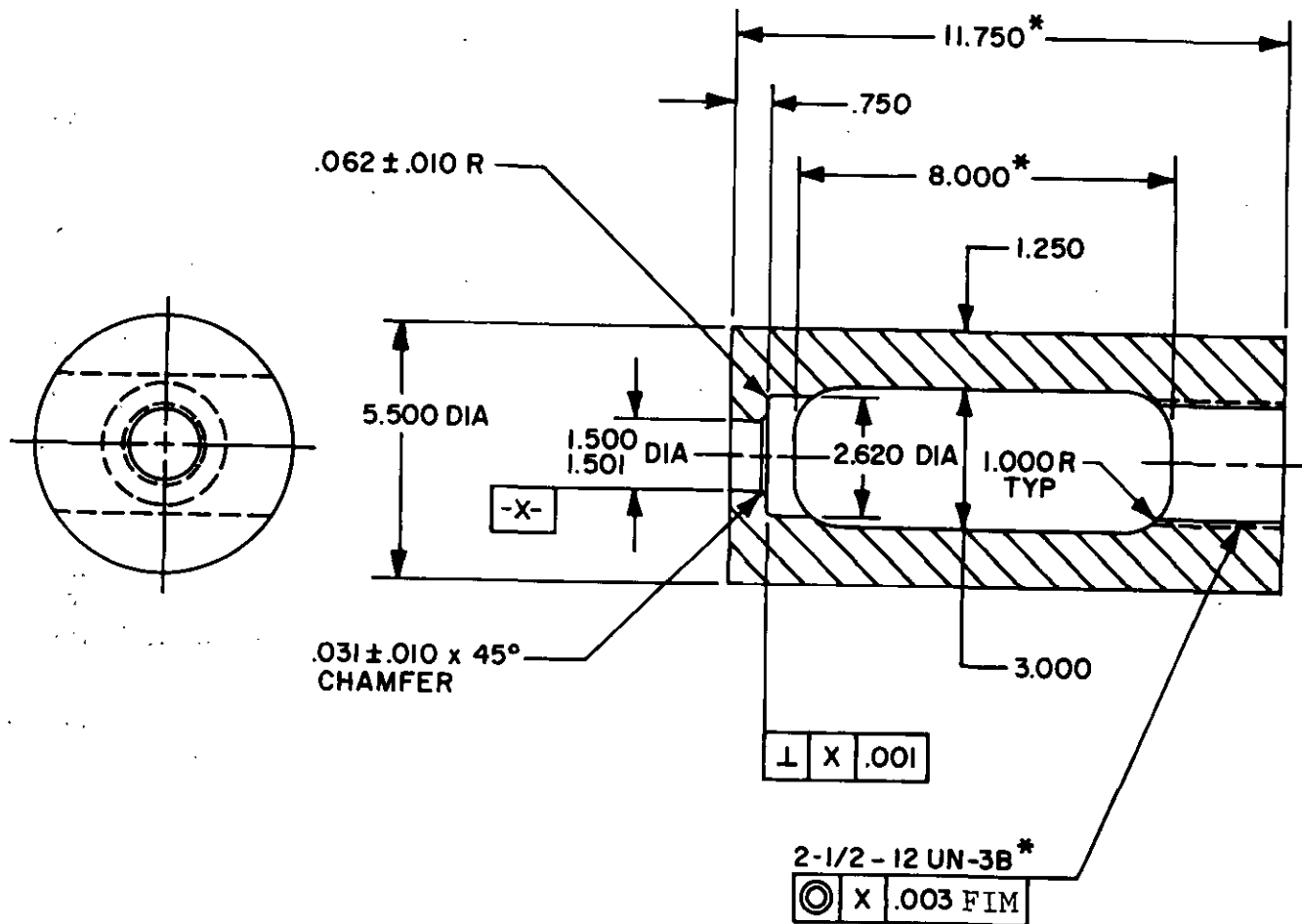

## NOTES:

1. Unless otherwise specified, tolerances  $\pm .030$ , angles  $\pm 2^\circ$ .
2. Surface texture: 125 microinches, in accordance with ANSI B46.1.
3. Material: AISI 4340, H-11, Maraging, or 17-4PH.
4. Heat treat: 35 HRC minimum.
5. Dimensions marked with an asterisk are optional.
6. Unless otherwise specified, dimensions in inches.

FIGURE 6. Holding fixture, fatigue 60,000 pounds capacity.



MIL-STD-1312B

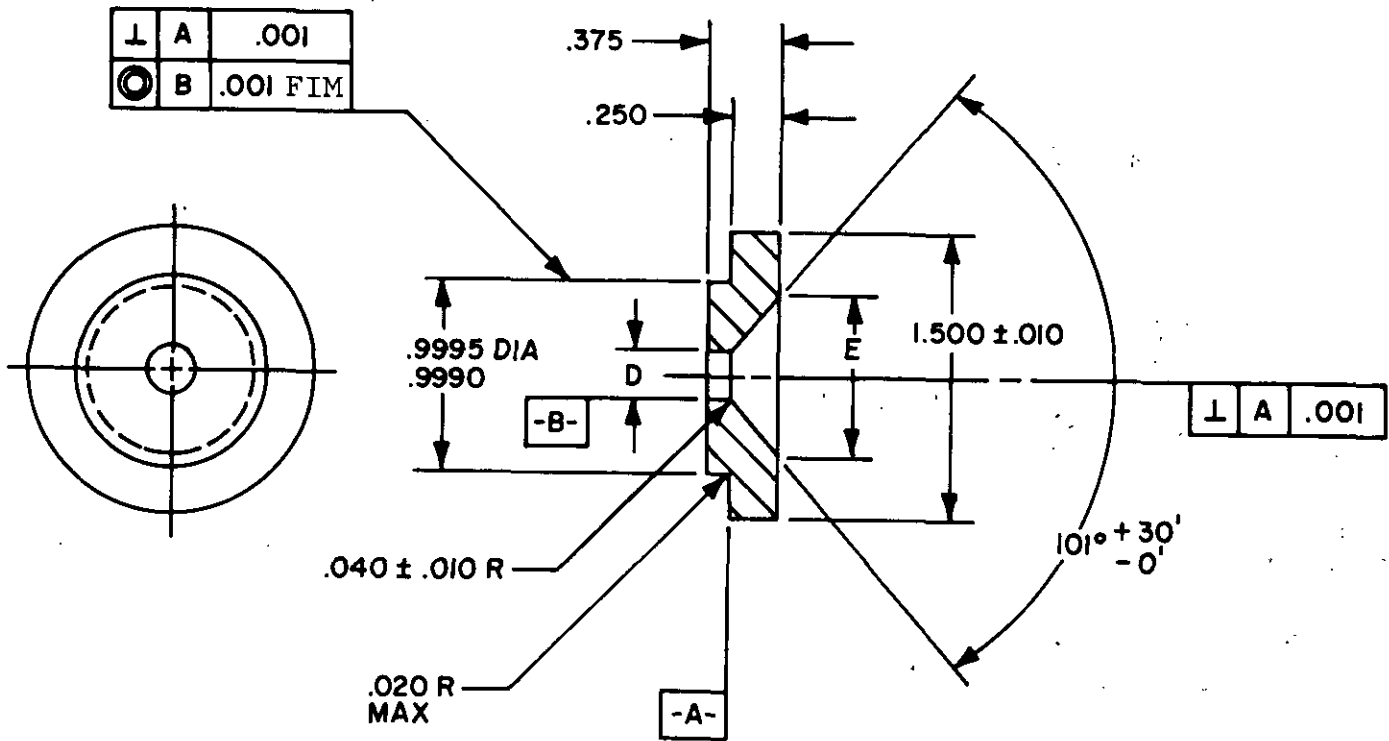

Nominal Fastener Diameter	D		E
	Max	Min	
#6	.140	.139	.360
#8	.166	.165	.420
0.190	.192	.191	.470
0.250	.252	.251	.588
0.313	.314	.313	.716

NOTES:

1. Unless otherwise specified, tolerances  $\pm .030$ .
2. Surface texture: 125 microinches, in accordance with ANSI B46.1.
3. Material: AISI 4340, H-11, maraging, or 17-4PH.
4. Heat treat: 35 HRC minimum.
5. Unless otherwise specified, dimensions in inches.

FIGURE 8. 100° Adapter, 5,000 pound capacity holding fixture.

MIL-STD-1312B

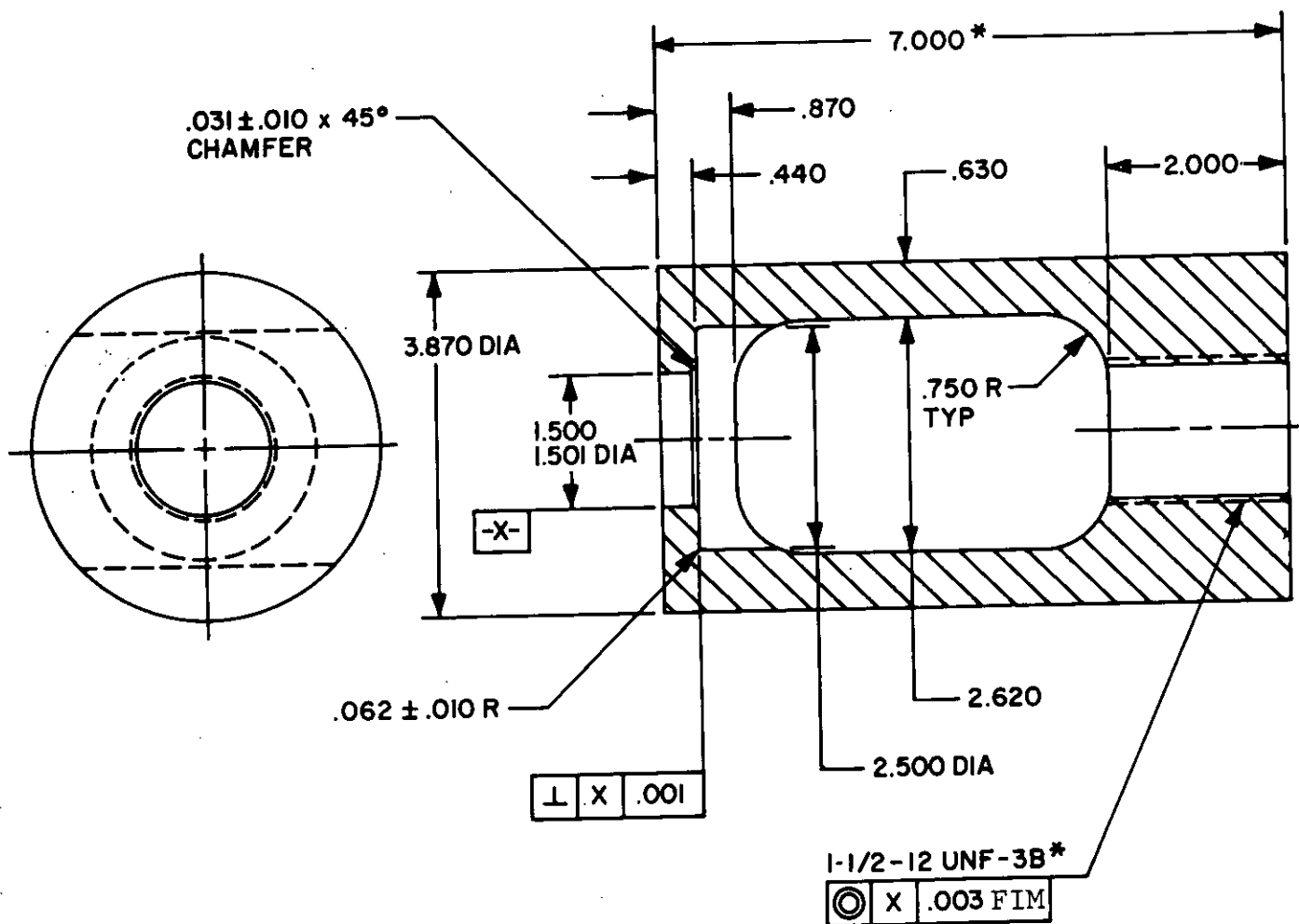

## NOTES:

1. Unless otherwise specified, tolerances  $\pm .030$ , angles  $\pm 2^\circ$ .
2. Surface texture: 125 microinches, in accordance with ANSI B46.1.
3. Material: AISI 4340, H-11, maraging, or 17-4PH.
4. Heat treat: 35 HRC minimum.
5. Dimensions marked with an asterisk are optional.
6. Unless otherwise specified, dimensions are in inches.

FIGURE 9. Holding fixture, fatigue 15,000 pound capacity.

MIL-STD-1312B

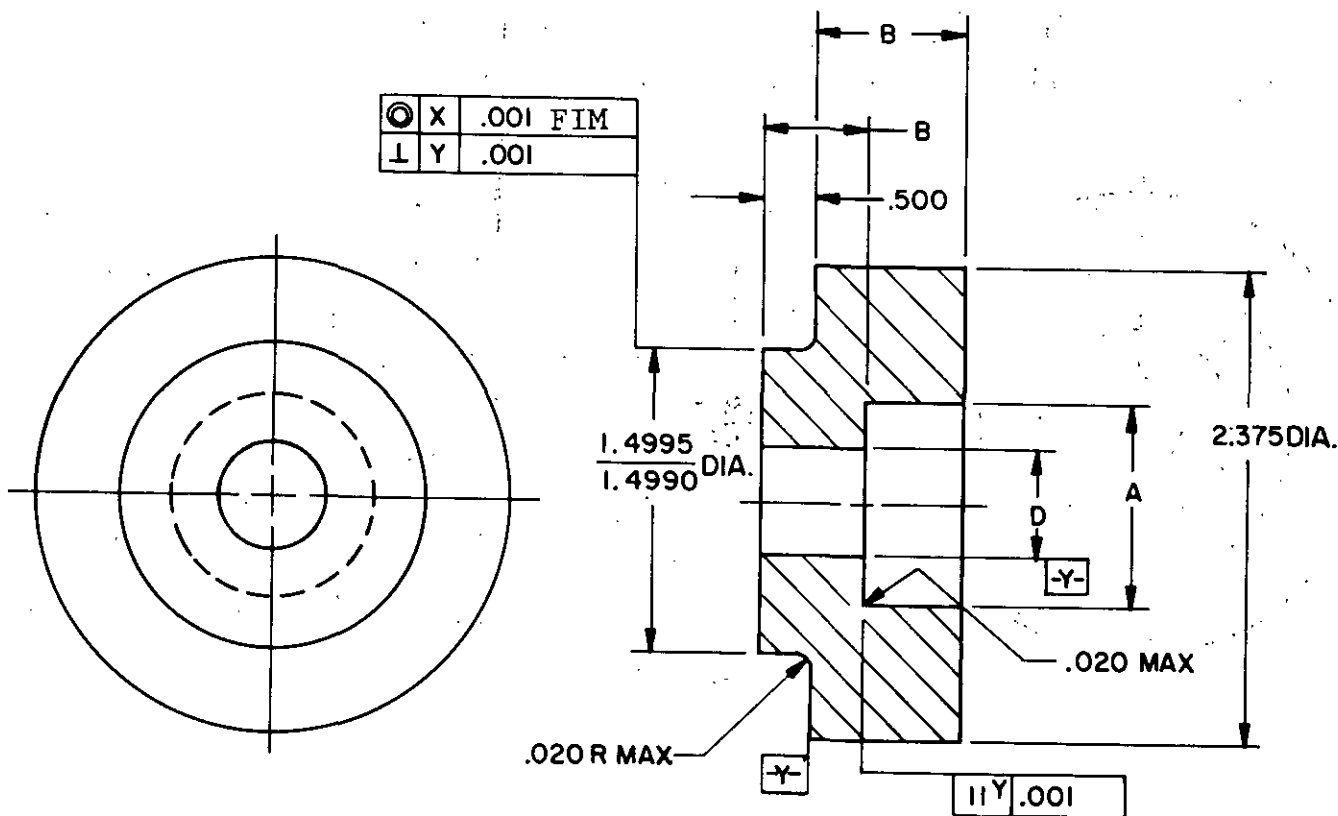

Fastener Size	A	B	D	
			Max	Min
#10	.505	.190	.192	.191
0.250	.562	.250	.252	.251
0.3125	.625	.312	.314	.313
0.375	.750	.375	.377	.376
0.4375	.875	.437	.439	.430
0.500	1.000	.500	.502	.501
0.5625	1.125	.562	.564	.564
0.625	1.250	.625	.627	.626
0.750	1.500	.750	.752	.751
0.875	1.7500	.875	.877	.876
1.000	2.000	1.000	1.002	1.001

NOTES:

1. Unless otherwise specified, tolerances  $\pm .030$ .
2. Surface texture: 125 microinches, in accordance with ANSI B46.1.
3. Material: AISI 4340, H-11, maraging or 17-4PH.
4. Heat treat: 35 HRC minimum.
5. Unless otherwise specified, dimensions in inches.

FIGURE 10. Plain adapter, 15,000 and 60,000 pound capacity holding fixture.

MIL-STD-1312B

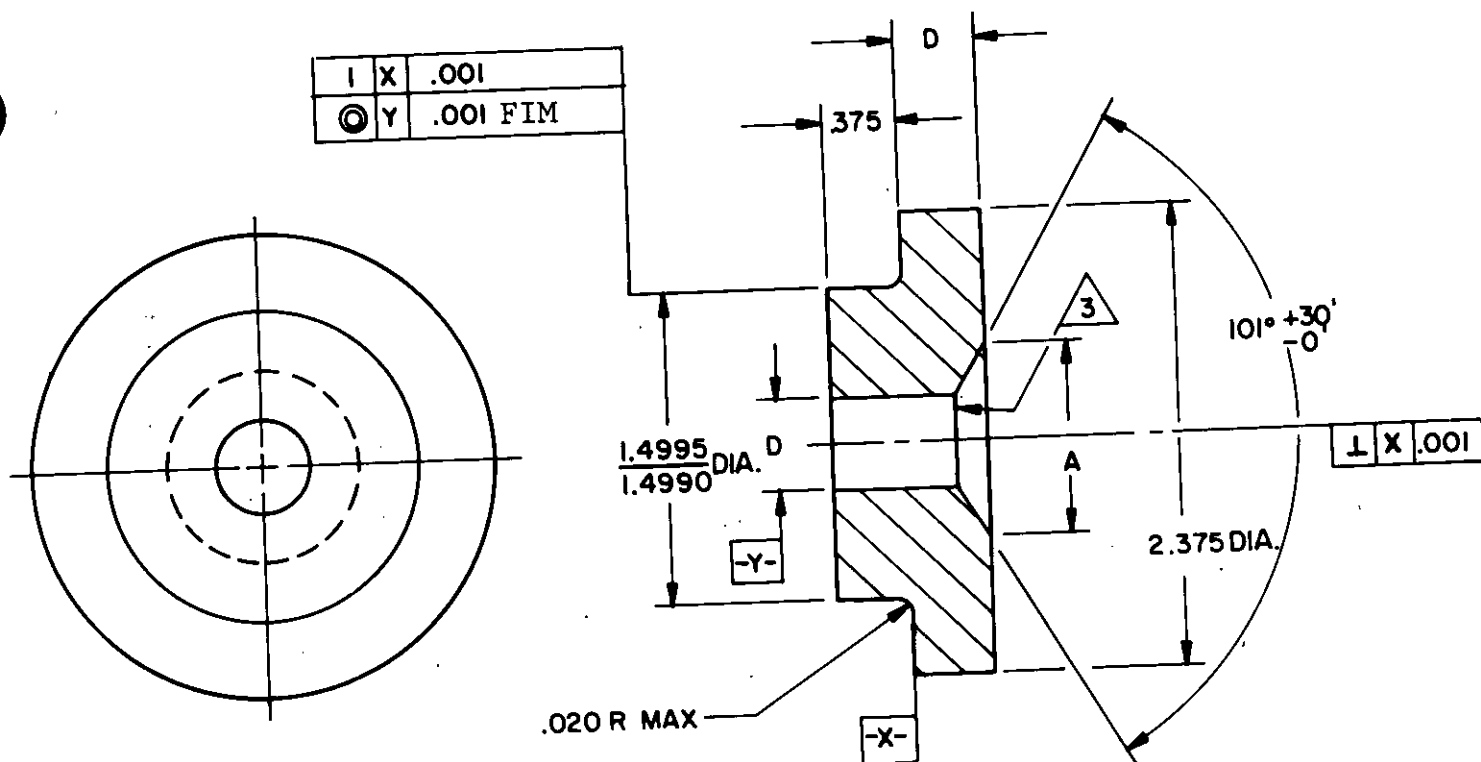

Bolt Size	A + .010	D	
		Max	Min
0.0190	.347	.192	.191
0.250	.463	.252	.251
0.3125	.591	.314	.313
0.375	.718	.377	.376
0.4375	.846	.438	.438
0.500	.973	.502	.501
0.5625	1.101	.564	.563
0.625	1.222	.627	.626

## NOTES:

1. Unless otherwise specified, tolerances  $\pm .030$ .
2. Surface texture: 125 microinches, in accordance with ANSI B46.1.
3. Break edge to a .030R
4. Material: AISI 4340, (UNS G43400) H-11, maraging or 17-4PH.
5. Heat treat: 35 HRC minimum.
6. Unless otherwise specified, dimensions in inches.

FIGURE 11. 100° adapter, 15,000 and 60,000 pound capacity holding fixture.

30

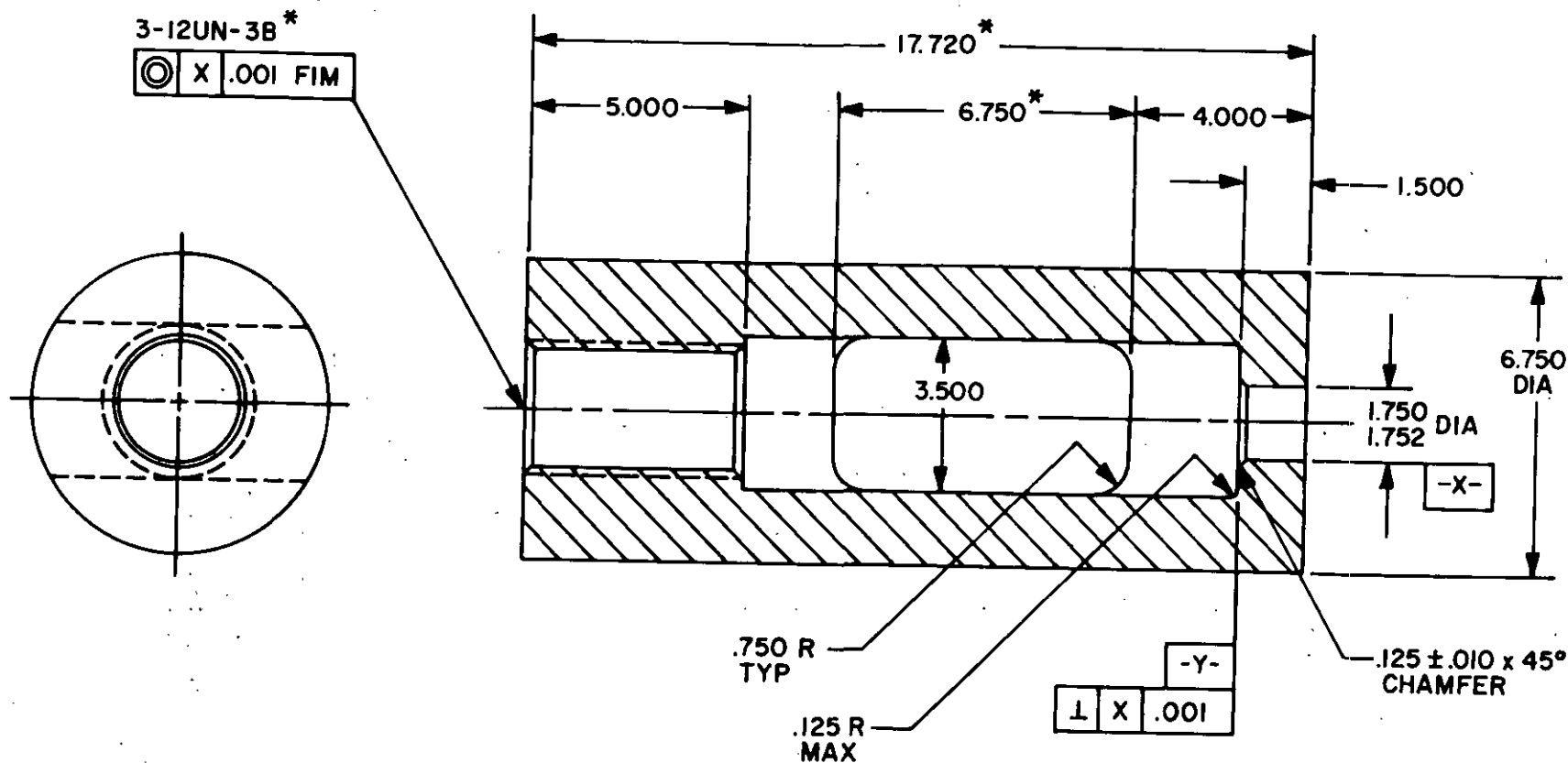

MIL-STD-1312B

NOTES:

1. Unless otherwise specified, tolerances  $\pm .030$ , angles  $+2^\circ$ .
2. Surface texture 125 microinches in accordance with ANSI B46.1.
3. Material: AISI 4340, (UNS G43400) H-11, maraging, or 17-4PH.
4. Heat treat: 35 HRC minimum.
5. Dimensions marked with an asterisk are optional.
6. Unless otherwise specified, dimensions in inches.

FIGURE 12. Holding fixture, fatigue 132,000 pound capacity.

## MIL-STD-1312B

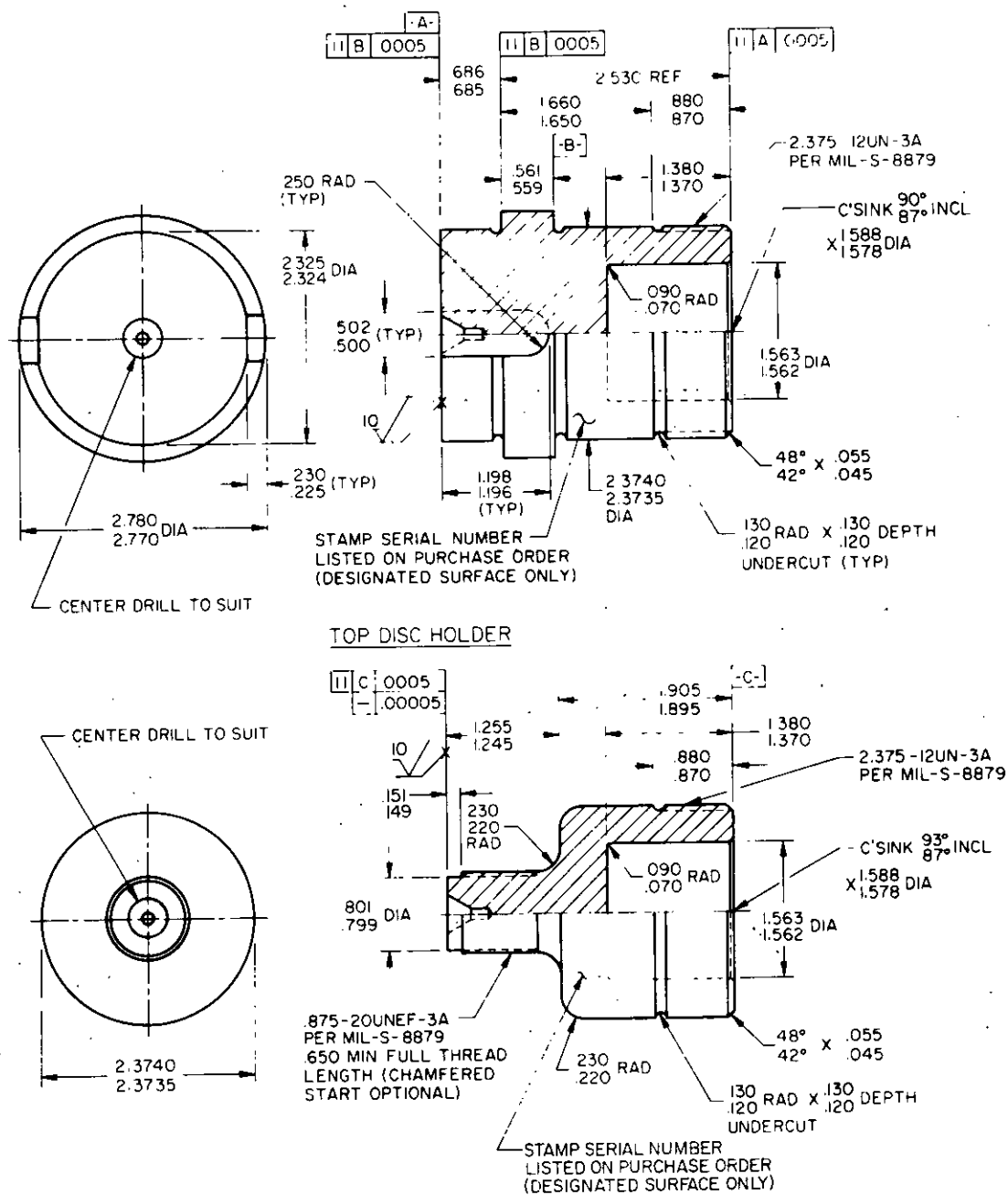

## GENERAL NOTES:

Material: Alloy steel

Heat treat: 46-51 HRC (De-Carb free condition)

Finish: Black oxide

Concentricity: All diameters concentric within .001 FIM.

Dimensions in inches.

Surface texture: Unless otherwise specified, 125 microinches, in accordance with ANSI B46.1.

FIGURE 13. Holding fixture, fatigue Amsler.

MIL-STD-1312B

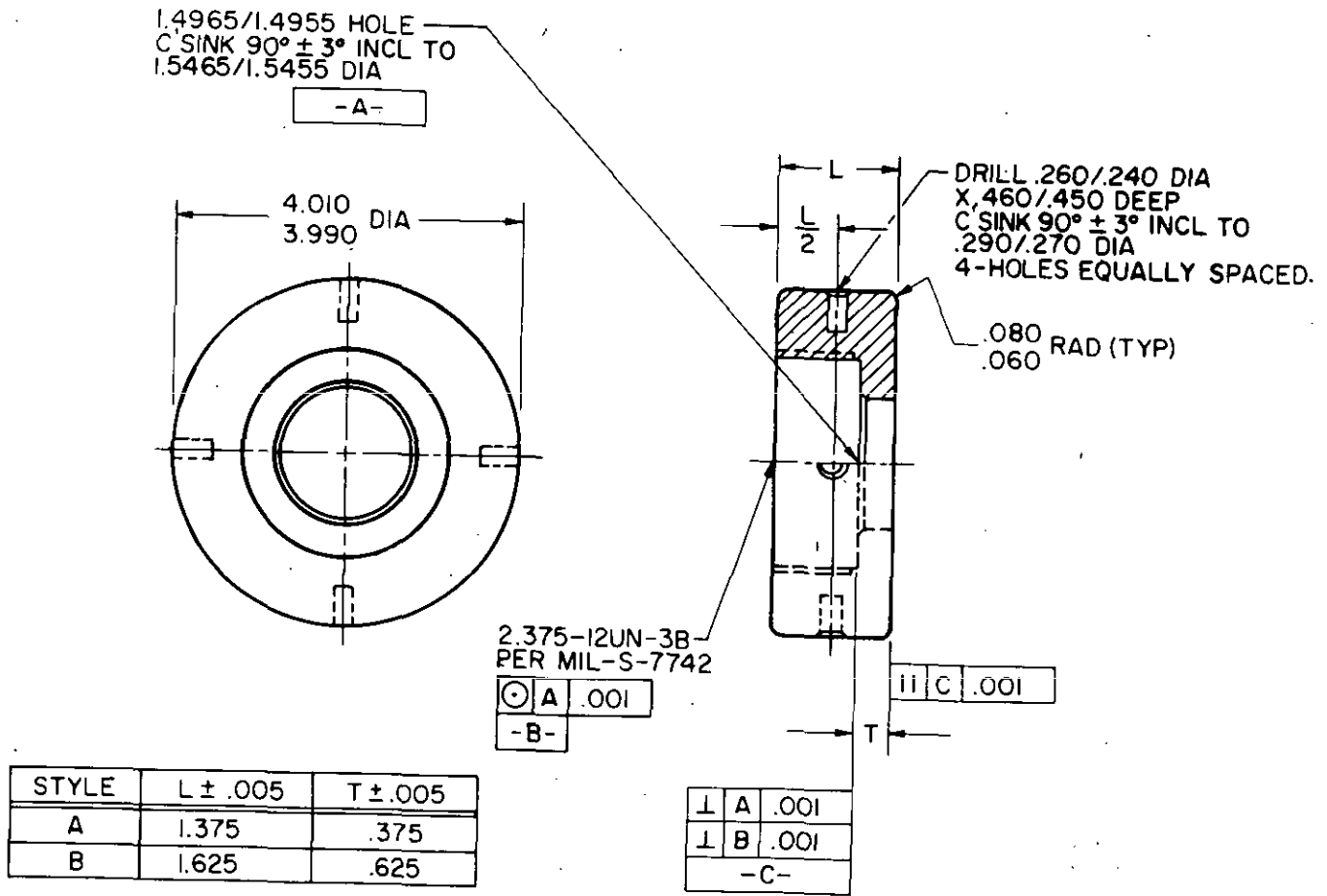

NOTES:

Material: Alloy steel.  
 Heat treat: 41-46 HRC (De-Carb free condition).  
 Finish: Black oxide  
 Unless otherwise specified, dimensions in inches.  
 Surface Texture: 125 microinches, in accordance with ANSI B46.1.

FIGURE 14. Disc holding nut fatigue fixture, Amsler.

MIL-STD-1312B

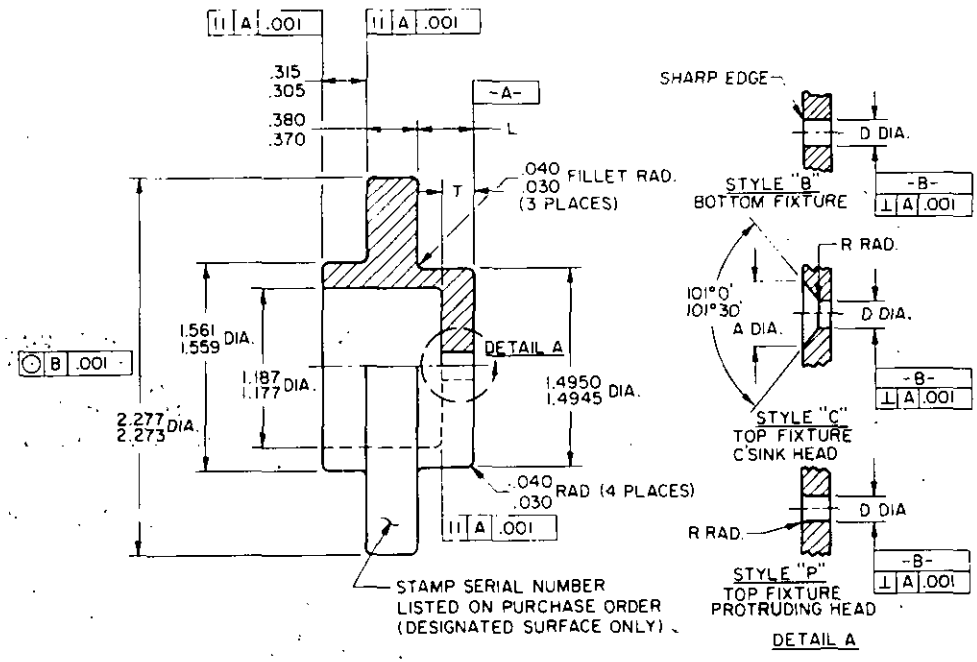

Nom Size	A Dia +.010 Style "C" Only	D DIA <sup>+.002</sup> <sub>-.000</sub>			L <sup>+.002</sup> <sub>-.000</sub>	R RAD	T <sub>+.005</sub>
		(a)	(b)	(c)			
#8	.320	.165			.375	(d)	.141
0.1875	.360	.190	.205	.221	.375		.172
0.250	.485	.250	.267	.284	.375		.172
0.3125	.610	.313	.330	.346	.375		.281
0.375	.735	.375	.392	.408	.375		.343
0.4375	.860	.437	.455	.470	.625		.406
0.500	.990	.500	.517	.533	.625		.468
0.5625	1.120	.562	.580	.595	.625		.530
0.625	1.250	.625	.642	.658	.625		.593
0.750		.750	.767	.784	.750		.688

- (a) "D DIA" for standard size fasteners.
- (b) "D DIA" for 1/64 oversize fasteners.
- (c) "D DIA" for 1/32 oversize fasteners.
- (d) "R RAD" to be designated by purchase order (e.g., .267 DIA x .040 RAD)

NOTES:

Material: 4340 alloy steel.  
 Heat treat: 41-46 HRC (De-Carb free condition)  
 Finish: Black oxide.  
 All radii to blend with adjacent surfaces.  
 Surface texture: In accordance with ANSI B46.1. All surfaces 63.  
 Dimensions in inches.  
 Identification example:

100 094 - Style "C" - .267 DIA x .040 RAD (Serial # CF40-26710)



FIGURE 15. Adapter, fatigue fixture.

MIL-STD-1312B

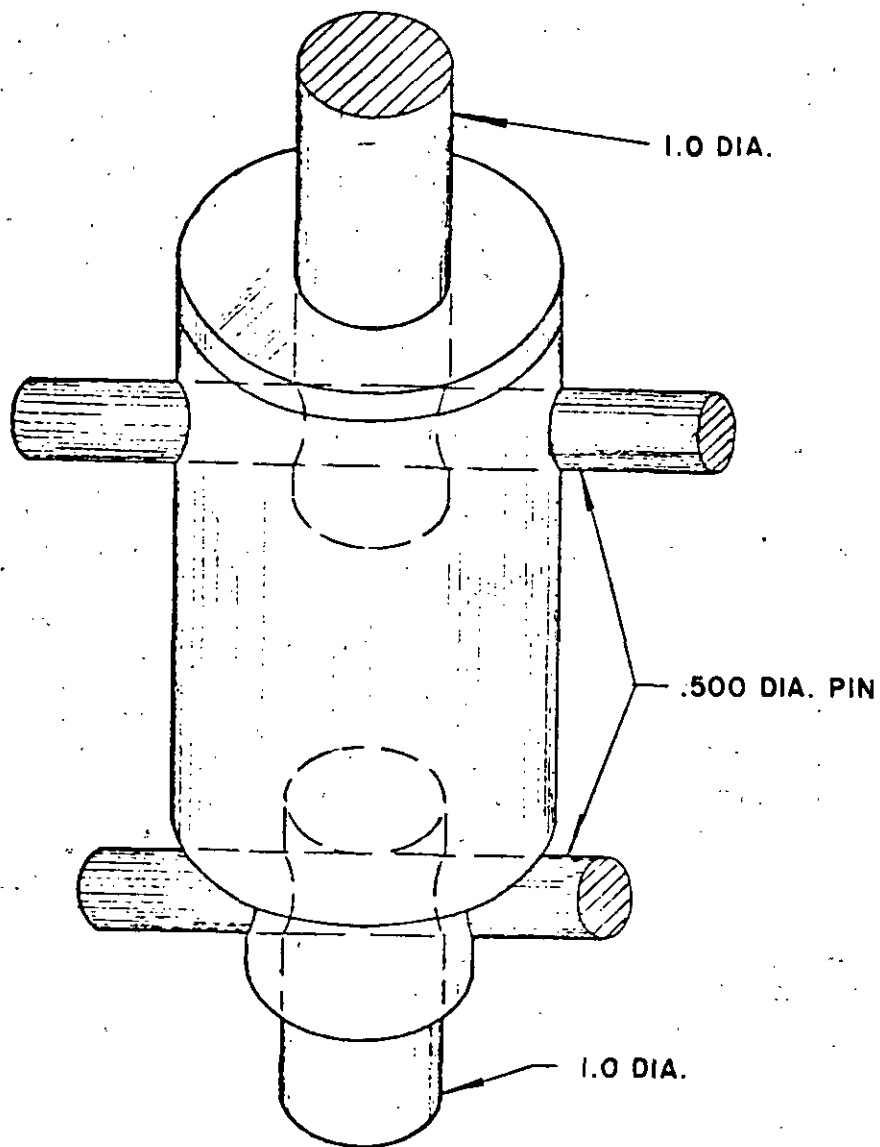
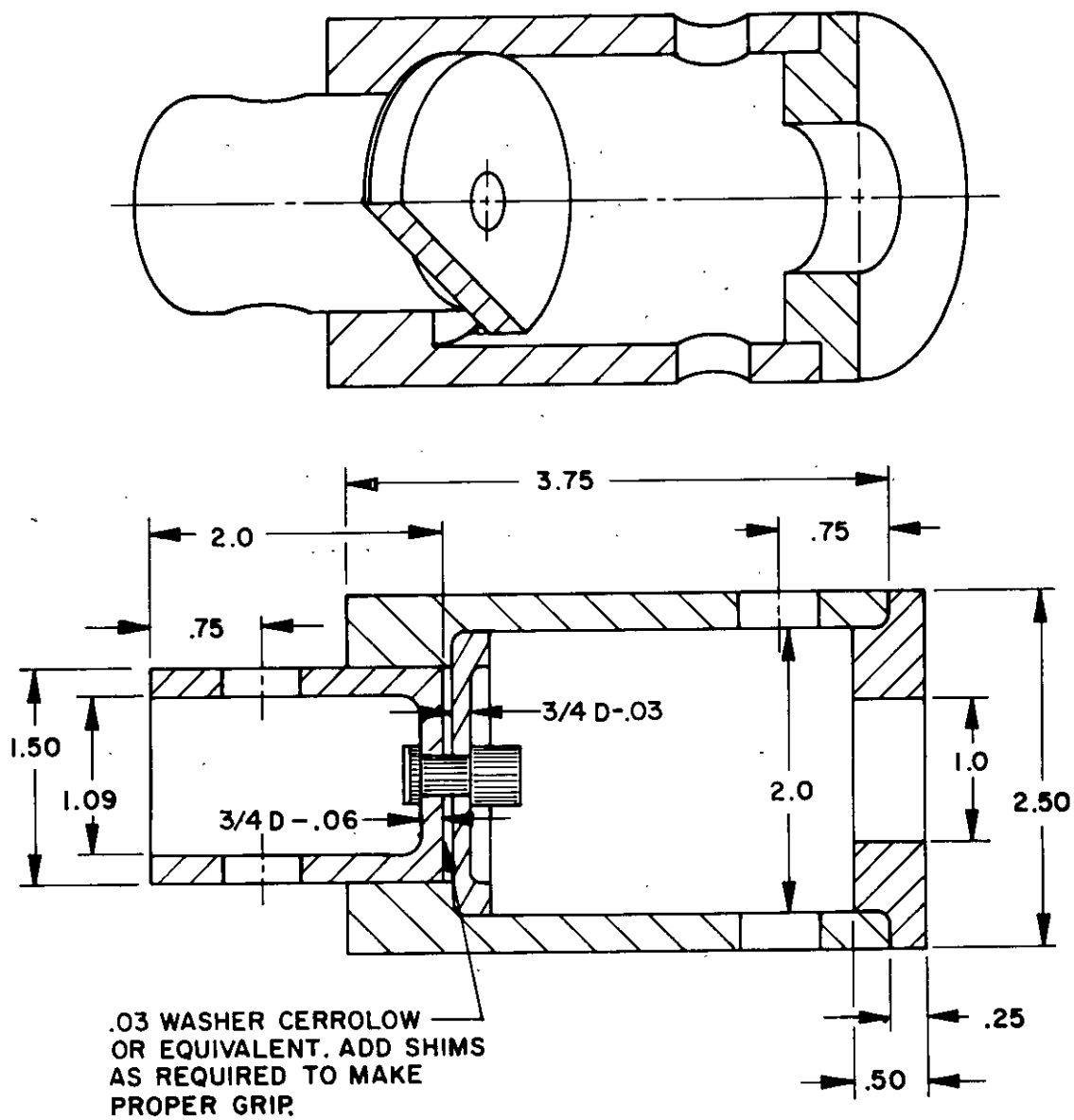
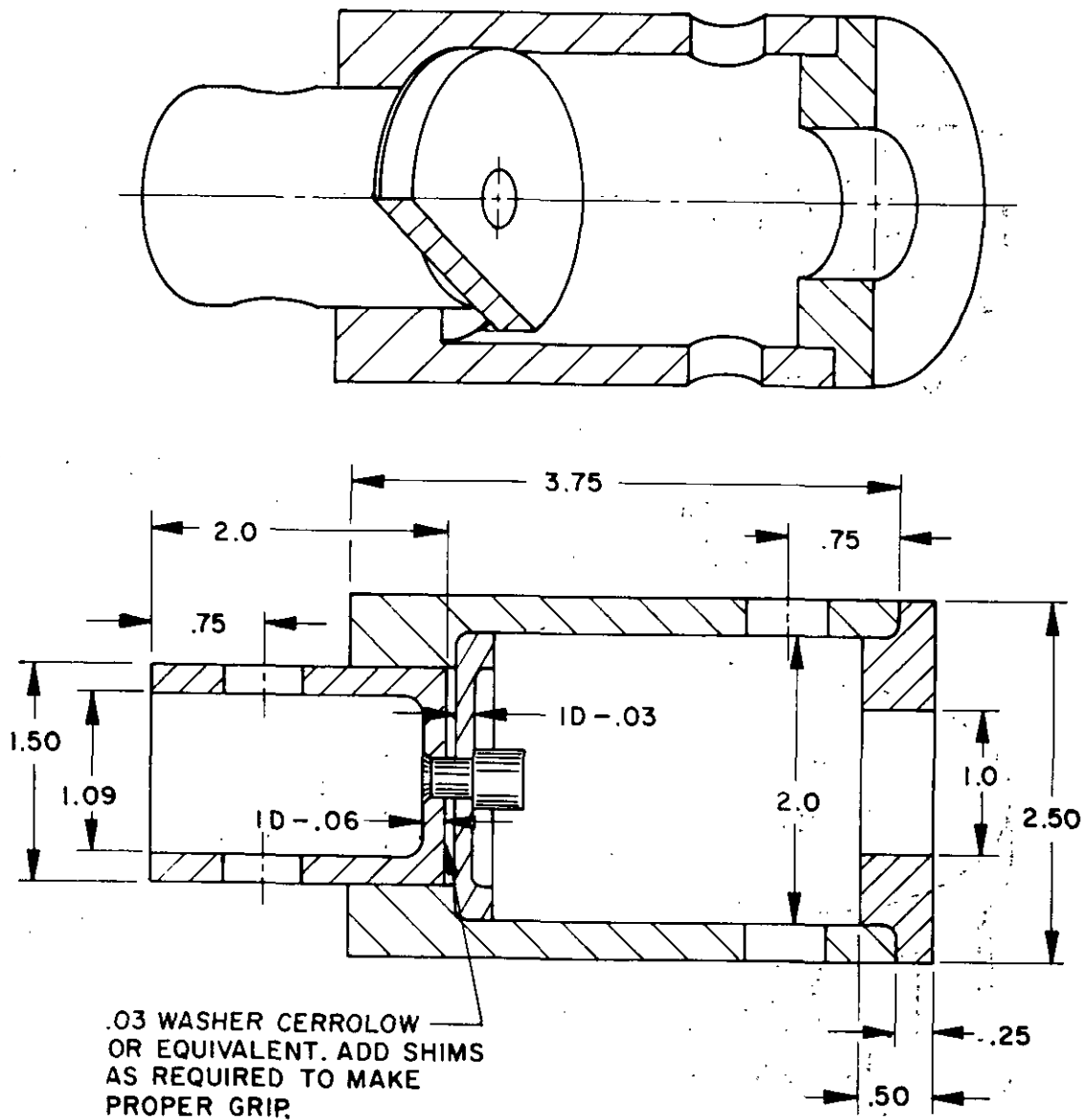

FIGURE 16.. Holding fixture.

MIL-STD-1312B

FIGURE 17. Protruding head adapter.

MIL-STD-1312B

FIGURE 18. Flush head adapter.

MIL-STD-1312B

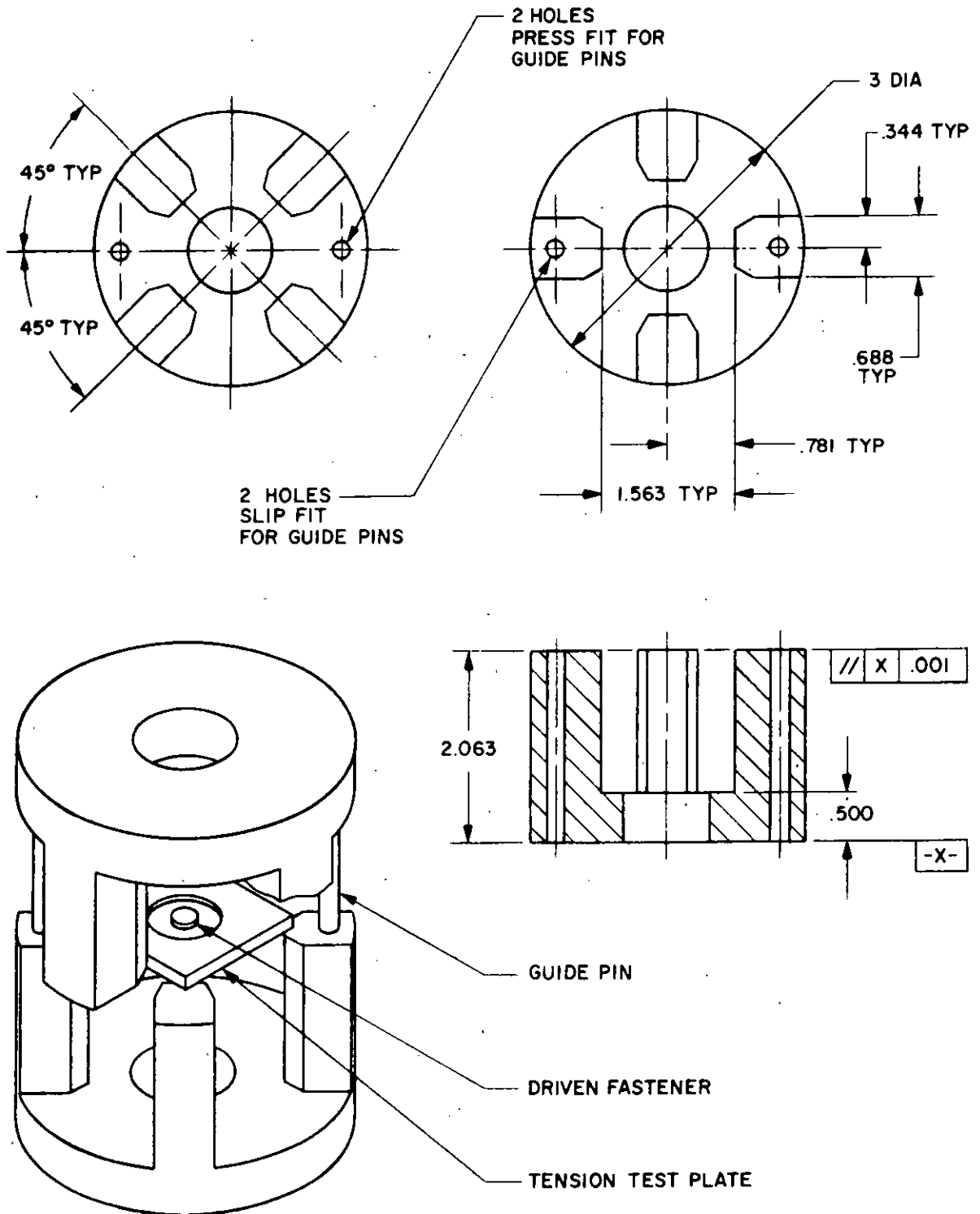
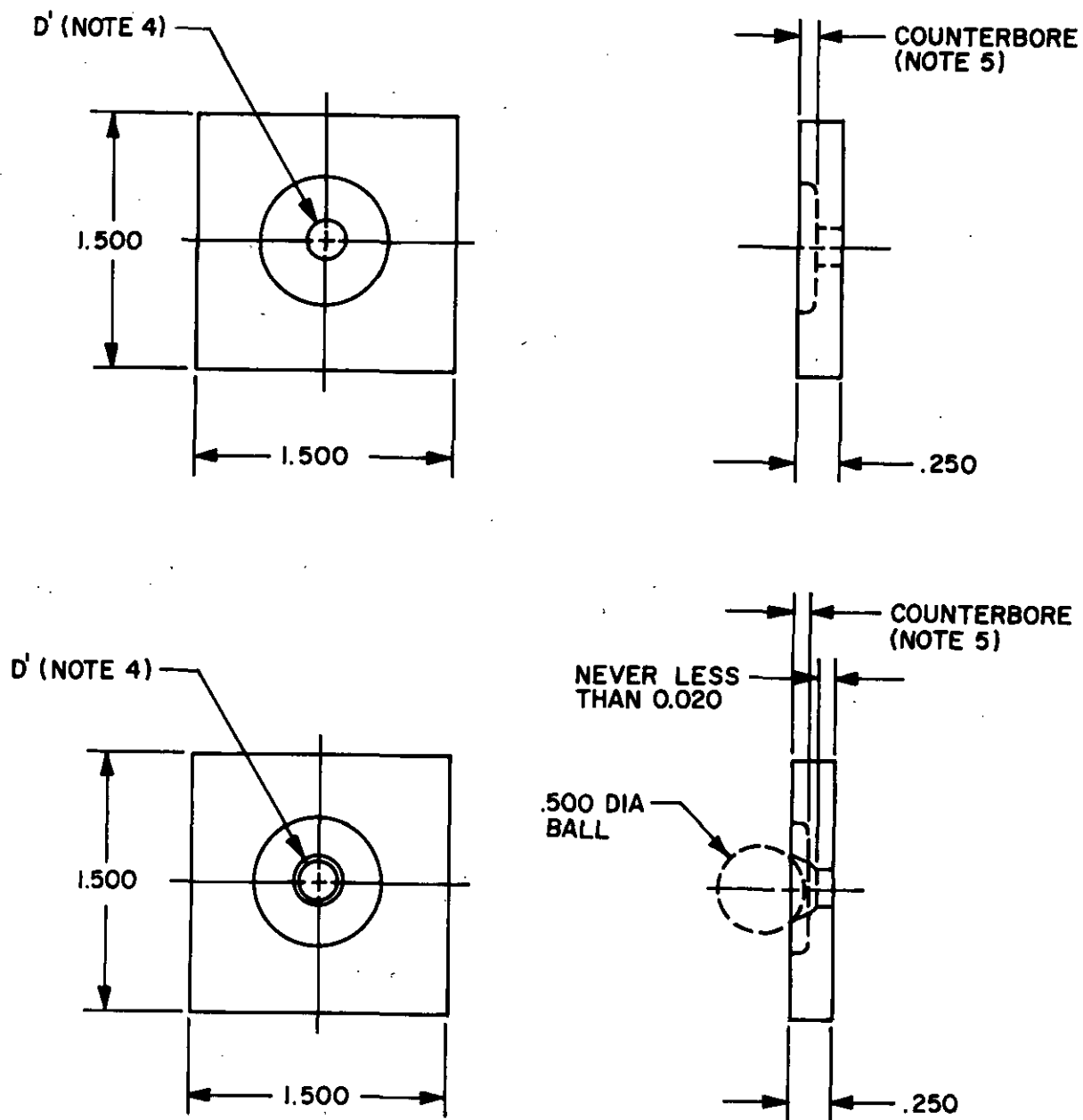

FIGURE 19. Compression loading fixture assembly.

## MIL-STD-1312B



## NOTES:

1. Material: Alloy steel.
2. Heat treat: 48-50 HRC
3. Machine or grind edges square with face.
4.  $D' = (D + .001) + .004 - .000$  where D equals the fastener maximum shank diameter.
5. Counterbore as required for grip.

FIGURE 20. Test plate.

# STANDARDIZATION DOCUMENT IMPROVEMENT PROPOSAL

(See Instructions - Reverse Side)

1. DOCUMENT NUMBER MIL-STD-1312B	2. DOCUMENT TITLE Fastener Test Methods
3a. NAME OF SUBMITTING ORGANIZATION	4. TYPE OF ORGANIZATION (Mark one) <input type="checkbox"/> VENDOR <input type="checkbox"/> USER <input type="checkbox"/> MANUFACTURER <input type="checkbox"/> OTHER (Specify): _____
5. PROBLEM AREAS	
a. Paragraph Number and Wording:	
b. Recommended Wording:	
c. Reason/Rationale for Recommendation:	
6. REMARKS	
7a. NAME OF SUBMITTER (Last, First, MI) - Optional	b. WORK TELEPHONE NUMBER (Include Area Code) - Optional
c. MAILING ADDRESS (Street, City, State, ZIP Code) - Optional	8. DATE OF SUBMISSION (YYMMDD)

(TO DETACH THIS FORM, CUT ALONG THIS LINE.)