

MIL-N-8984
28 January 1972

MILITARY SPECIFICATION

NUT, SELF-LOCKING, STEEL, 260 KSI F_{tu}, 450° F

This specification is mandatory for use by all
Departments and Agencies of the Department
of Defense

1. SCOPE

1.1 This specification covers self-locking, alloy steel nuts for use in temperatures up to and including 450° F, in conjunction with tensile bolts and screws having class UNJF-3A threads conforming to MIL-S-8879.

2. APPLICABLE DOCUMENTS

2.1 The following documents, of the issue in effect on date of invitation for bids or request for proposal, form a part of this specification to the extent specified herein:

SPECIFICATIONS

Federal

QQ-P-416	Plating, Cadmium (Electrodeposited)
TT-E-751	Ethyl Acetate, Technical, Organic Coatings Use
TT-I-735	Isopropyl Alcohol
TT-M-261	Methyl-Ethyl-Ketone (for use in Organic Coatings)
TT-N-97	Naphtha; Aromatic
PPP-B-566	Boxes, Folding, Paperboard
PPP-B-601	Boxes, Wood, Cleated-Plywood
PPP-B-621	Boxes, Wood, Nailed and Lock-Corner

FSC 5310

MIL-N-8984

SPECIFICATIONS

Federal (Contd)

PPP-B-636 Box, Fiberboard

PPP-B-665 Boxes, Paperboard, Metal Stayed (including Stay Material)

PPP-B-676 Boxes, Set-Up, Paperboard

Military

MIL-P-116 Preservation, Methods of

MIL-S-5000 Steel, Chrome-Nickel-Molybdenum (8740) Bars and Reforging Stock

MIL-C-5541 Chemical Films for Aluminum and Aluminum Alloys

MIL-S-6049 Steel, Chrome-Nickel-Molybdenum (E4340) Bars and Reforging Stock

MIL-I-6868 Inspection Process, Magnetic Particle

MIL-F-7179 Finishes and Coatings; General Specification for Protection of Aircraft and Aircraft Parts

MIL-S-7502 Sealing Compound, Integral Fuel Tanks and Fuel Cell Cavities, High Adhesion, Accelerator Required

MIL-A-8625 Anodic Coatings, for Aluminum and Aluminum Alloys

MIL-S-8802 Sealing Compound, Temperature-Resistant, Integral Fuel Tanks and Fuel Cell Cavities, High Adhesion

MIL-S-8879 Screw Threads, Controlled Radius Root with Increased Minor Diameter; General Specification for

SPECIFICATIONS

Military (Contd)

MIL-B-8907	Bolt, Tensile, Steel, 260 KSI Ftu, 450 ^o F, External Wrenching, Flanged Head
MIL-W-8982	Wrenches, Splined Socket and Box, Square Drive, High Strength, Thin Wall
MIL-L-10547	Liners, Case, and Sheet, Overwrap, Water- Vaporproof of Waterproof, Flexible
MIL-C-81562	Coating, Cadmium and Zinc (Mechanically Deposited)

STANDARDS

Military

MIL-STD-105	Sampling Procedures and Tables for Inspection by Attributes
MIL-STD-129	Marking for Shipment and Storage
MIL-STD-1312	Fasteners, Test Methods
MS21085	Nut, Self-Locking, Steel, 260 KSI Ftu, 450 ^o F, Flanged, MS33787 Wrenching Element
MS21296	Bolt, Tensile, Steel, 260 KSI Ftu, 450 ^o F, External Wrenching, Flanged Head
ANSI(USAS)B-46.1	Surface Texture Waviness, and Lay

(When requesting applicable documents, refer to both title and number. Copies of unclassified documents may be obtained from the Commanding Officer, Naval Publications and Forms Center, 5801 Tabor Avenue, Philadelphia, Pennsylvania 19120. Requests for copies of classified documents should be addressed to the Naval Publications and Forms Center, via the cognizant Government representative.)

MIL-N-8984

3. REQUIREMENTS

3.1 Qualification - The MS21085 nut furnished under this specification shall be a product which is in accordance with the applicable approved standard and has been tested and has passed the qualification tests specified herein, and is listed on or is approved for listing on the applicable Qualified Products List (see 6.2).

3.1.1 Requalification - Requalification will be required in the event any change is made in the product design, material, heat treatment, finish, or lubrication.

3.2 Definitions - For definitions of terms used in this specification (see 6.4).

3.3 Materials - The nuts shall be fabricated from material as specified on the nut standard.

3.3.1 Decarburization - The permissible depth of decarburization (partial plus full) shall not exceed 0.003 inch. Heat-treating furnace atmospheres shall not increase the surface carbon content above that allowed for the core.

3.4 Construction - Nuts shall be of the prevailing torque-type. The locking device shall not operate by means of separate movement as a result of installation and shall not depend upon pressure on the bearing surface for locking action.

3.4.1 Wrenching element - Wrenching element shall be in accordance with applicable standard.

3.4.2 Bearing surface - The bearing surface shall be normal to the axis of the pitch diameter of the threads within the values specified on the applicable standard or drawing.

3.4.3 Threads - Unless otherwise specified, thread dimensions shall be in accordance with MIL-S-8879. Threads used on the locking device may be displaced in any manner which will provide self-locking nuts conforming to this specification. Thread gaging shall be performed after plating in accordance with the applicable thread specification, (except that the nut with locking device incorporated but without lubricant shall allow the go plug gage members to enter a minimum of three-fourths turn before engagement of the locking device). When lubricant prevents use of standard gages, the nut shall permit free rotational (finger torqued) bolt engagement of at least three-fourths turn.

3.5 Plating - The nuts shall be cadmium plated in accordance with the applicable standard or drawing.

3.6 Dry film lubricant - The nut when provided with a dry film lubricant coating shall pass the applicable tests specified in 4.5.8. The qualified products list shall identify the lubricant coating and it shall not be changed without requalification of the nut.

3.7 Axial strength - The nuts shall have a minimum axial strength of not less than the values specified in table I when tested as specified in 4.5.2.

3.8 Torque -

3.8.1 Wrench torque - The nuts shall withstand the wrench torque values specified in table I, when tested as specified in 4.5.3.1. Upon completion of the test, the nut shall show no indications of permanent deformation which may prevent its proper application and removal with a socket-type wrench conforming to MIL-W-8982. The nuts shall show no evidence of cracking when tested in accordance with 4.5.7.

3.8.2 Torque effectivity, room temperature - The nuts shall not exceed the room temperature maximum locking torque nor produce less than the minimum breakaway torque specified in table III, when tested as specified in 4.5.3.2.

3.8.2.1 Torque effectivity, 450° F - The nuts shall not exceed the room temperature after bake maximum locking torque nor produce less than the minimum breakaway torque specified in table III, when tested as specified in 4.5.3.2.1.

3.8.3 Locking torque - The nuts shall not exceed the room temperature maximum locking torque nor produce less than the 1st cycle minimum breakaway torque specified in table III, when tested as specified in 4.5.3.3.

3.8.4 Permanent set - The nuts shall not exceed the maximum locking torque nor be less than the minimum breakaway torque specified in table III, when tested as specified in 4.5.3.4.

3.9 Accelerated vibration - The nuts shall withstand the vibration test specified in 4.5.4.

MIL-N-8984

TABLE I. Axial Strength and Wrench Torque

Cross Sectional Area (Sq-In)	Nominal Size	Axial Strength Minimum (Lbs.)	Wrench Torque Minimum (In-Lbs.)
.0226	10-32	5,880	100
.0404	1/4-28	10,500	250
.0640	5/16-24	16,600	560
.0951	3/8-24	24,700	860
.1288	7/16-20	33,500	1,300
.1717	1/2-20	44,600	1,750
.2176	9/16-18	56,600	2,350
.2724	5/8-18	70,800	3,050
.3952	3/4-16	103,000	5,000
.5392	7/8-14	140,000	8,500
.7027	1 -12	183,000	12,000
.9007	1-1/8-12	234,000	15,300
1.1232	1-1/4-12	292,000	19,000
1.3703	1-3/8-12	356,000	22,000
1.6420	1-1/2-12	427,000	26,000

Axial Strength Values determined from Formula $W_a = F_{tu} A$;
Where A = Cross sectional area (Sq-in) as tabulated.

Area based on maximum P. D of bolt thread.

$F_{tu} = 260$ KSI

$W_a =$ Axial Strength (lbs.)

TABLE II. Stress Durability and Stress Corrosion

Nominal Size	Nominal Grip Length of Bolt (In.)	Bolt Elongation (In.)
10-32	2.00	.0083
1/4-28	2.00	.0099
5/16-24	2.00	.0091
3/8-24	2.00	.0096
7/16-20	2.50	.0115
1/2-20	2.50	.0122
9/16-18	2.50	.0125
5/8-18	2.75	.0139
3/4-16	2.75	.0147
7/8-14	2.75	.0153
1 -12	3.00	.0169
1-1/8-12	3.00	.0178
1-1/4-12	3.00	.0185
1-3/8-12	3.00	.0191
1-1/2-12	3.00	.0198

TABLE II (Cont'd)

MIL-N-8984

- (a) Test bolt shall be stressed by torquing the nut until elongation is within .0005 of value specified. This elongation will indicate a stress of 50% of the minimum axial strength.
- (b) Bolt elongations are calculated using bushing assembly lengths "A" (dimensions "L" per table IX).
- (c) Other bolt grip lengths permissible. Calculate elongation per Test 14, MIL-STD-1312, using values for "A" equal to nominal grip length plus three times the thread pitch.

3.10 Stress durability - The nuts shall show no evidence of cracking when tested as specified in 4.5.5.

3.11 Stress corrosion - The nuts shall show no evidence of cracking when tested as specified in 4.5.6.

3.12 Discontinuities - Discontinuities in the nuts shall not exceed the depth limitations shown in table IV when examined as specified in 4.5.7. Care shall be exercised not to confuse cracks with discontinuities. A crack is defined as a clean crystalline break passing through the grain or grain boundary without the inclusion of foreign elements. Cracks are not permitted in any location.

3.13 Hardness - Hardness shall be as specified on the applicable standard or drawing.

3.14 Workmanship - Workmanship shall be consistent with the type of product, finish, and the class of thread fit specified. Sharp edges shall be broken; hanging burrs and slivers shall be removed.

4. QUALITY ASSURANCE PROVISIONS

4.1 Responsibility for inspection - Unless otherwise specified in the contract or purchase order, the supplier is responsible for the performance of all inspection requirements as specified herein. Except as otherwise specified in the contract or order, the supplier may use his own or any other facilities suitable for the performance of the inspection requirements specified herein, unless disapproved by the Government. The Government reserves the right to perform any of the inspections set forth in the specification where such inspections are deemed necessary to assure supplies and services conform to prescribed requirements.

4.2 Classification of tests - The inspection and testing of nuts shall be classified as follows:

MIL-N-8984

- (a) Qualification Tests (4.3)
- (b) Quality Conformance Tests (4.4)

4.3 Qualification tests -

4.3.1 Sampling instructions - Qualification test samples (see table V) shall consist of 50 nuts for each size upon which qualification is desired. All bolts, screws, and mandrels necessary for tests specified herein shall be furnished by the manufacturer. Complete description and name of lubricating material used on the nuts shall be furnished. Samples shall be identified as required and forwarded to the activity responsible for qualification, designated in the letter of authorization from that activity (see 6.3).

4.3.2 Tests - The qualification tests shall consist of all the tests and examinations of this specification as specified under 4.5.

4.3.3 Certified test report - The manufacturer shall furnish a certified test report showing that the manufacturer's product satisfactorily conforms to this specification. The test report shall include, as a minimum, actual results of the tests specified herein. When this report is submitted, it shall be accompanied by a dated drawing which describes the manufacturer's product by specifying pertinent dimensions and tolerances, composition of material selected, coating or plating applied, and the heat treatment. The manufacturer's part number for each size shall be included on the above drawing.

4.4 Quality conformance tests - The quality conformance tests shall consist of those examinations and tests listed in 4.4.2 on samples selected in accordance with sampling plans A, B, and C

4.4.1 Selection of samples - Sample nuts shall be selected at random from each lot as specified herein.

4.4.1.1 Lot - A lot shall consist of finished nuts of the same type and diameter fabricated by the same process, from one heat of material, heat treated in the same manner, and produced as one continuous run, order, or part thereof.

4.4.1.2 Sampling plan A - Sampling sizes for examination of product and thread fit (4.5.1), and bearing surface squareness (4.5.1.1) shall be in accordance with MIL-STD-105 inspection level I, as specified in table VI. The acceptance and rejection criteria shall be applied for the following acceptance quality levels (AQL's) pertaining to the corresponding class of characteristics:

Major AA	0.0 percent
Major A	0.4 percent
Major B	1.5 percent
Major C	2.5 percent
Major D	4.0 percent

TABLE III. Torque

Nominal Size	Seating Torque For Torque Effectivity Test (In-Lbs.)	Maximum Locking Torque <u>1/</u>		Minimum Breakaway Torque (In-Lbs.)	Minimum Breakaway 1st Cycle (In-Lbs.)	Assembly Torque Vibration (In-Lbs.)
		Room Temperature (In-Lbs.)	Room Temperature After Bake (In-Lbs.)			
10-32	75	18	36	2.0	3.5	36
1/4-28	190	30	60	3.5	7	60
5/16-24	410	60	120	6.5	12	120
3/8-24	650	80	160	9.5	18	160
7/16-20	1,000	100	200	14.0	26	200
1/2-20	1,500	150	300	18.0	34	300
9/16-18	1,900	200	400	24.0	46	400
5/8-18	2,550	300	600	32.0	60	600
3/4-16	4,500	400	800	50.0	90	
7/8-14	7,650	600	1,200	70.0	135	
1-12	10,800	800	1,600	90.0	180	
1-1/8-12	13,800	900	1,800	117.0	234	
1-1/4-12	17,100	1,000	2,000	143.0	285	
1-3/8-12	20,000	1,100	2,200	165.0	330	
1-1/2-12	23,000	1,250	2,500	195.0	386	

1/ Values apply to nuts as lubricated by manufacturer.

4.4.1.2.1 Classification of Defects - The classification of defects for self-locking nuts shall be

Major AA

Visual inspection of package marking.

Major A

Visual presence of locking configuration.
Bearing surface squareness.

MIL-N-8984

Major B

Thread Fit
Surface Plating

Major C

Wrench Size - Height of wrenchable portion
Overall Height - Diameter of bearing surface
Loose or hanging burrs - Concentricity of threads
to base diameter.
All dimensional characteristics not covered above.

Major D

Part identification per applicable standard or drawing.

4.4.1.3 Sampling plan B - For the axial strength test (4.5.2), hardness test (4.5.2.1), locking torque test (4.5.3.3), and permanent set (4.5.3.4), the samples shall be selected in accordance with table VII.

TABLE IV. Discontinuity Depth Limits, Maximum, Inch 1/

Nominal Thread Size	Limits	Rejectable Criteria
10-32	.005	Any crack, regardless of location. Discontinuities in excess of specified limits.
1/4-28	.005	
5/16-24	.005	
3/8-24	.006	
7/16-20	.007	
1/2-20	.008	
9/16-18	.009	
5/8-18	.010	
3/4-16	.010	
7/8-14	.010	
1 -12	.011	
1-1/8-12	.011	
1-1/4-12	.012	
1-3/8-12	.012	
1-1/2-12	.012	

1/ Samples of nuts having indications may be sectioned and microexamined to determine whether the indications are due to tool or die marks, or due to discontinuities, and to determine conformance of discontinuities to the depth limits specified in table IV.

TABLE V. Qualification Test Plan

Test	Paragraph	Nuts Required	Bolts or Studs Required
Examination of Product	4.5.1	All	0
Thread Fit	4.5.1	All	0
Bearing Surface Squareness	4.5.1.1	3	0
Axial Strength	4.5.2	5	5
Hardness	4.5.2.1	6	0
Wrench Torque	4.5.3.1	5	5
Torque Effectivity, Room Temp. (Locking Element)	4.5.3.2	5	5
Torque Effectivity, 450 ⁰ F (Locking Element)	4.5.3.2.1	5	5
Locking Torque	4.5.3.3	3	3
Permanent Set	4.5.3.4	3	3
Stress Corrosion	4.5.6	6	6
Accelerated Vibration	4.5.4	5	5
Stress Durability	4.5.5	6	6
Discontinuities	4.5.7	All	0
Suitability of Lubricant Coatings	4.5.8		

4.4.1.4 Sampling plan C - For Stress Durability (4.5.5), sample size shall be 5 for each lot and the acceptance number zero.

4.4.2 Test - The quality conformance tests shall consist of:

- (a) Examination of Product (4.5.1 and 4.5.1.1)
- (b) Axial Strength (4.5.2)
- (c) Locking Torque (4.5.3.3)
- (d) Discontinuities (4.5.7)
- (e) Hardness (4.5.2.1)

In addition, the nuts shall pass any of the other tests specified herein which are considered necessary by the procuring activity to determine conformance to this specification.

4.5 Test methods -

MIL-N-8984

TABLE VI. Inspection Sampling Plan A Normal Inspection (Single Sampling)

Lot Size	0.4% AQL			1.5% AQL			2.5% AQL			4.0% AQL		
	Sample Size	Ac	Re	Sample Size	Ac	Re	Sample Size	Ac	Re	Sample Size	Ac	Re
Under 26	25	0	1	8	0	1	5	0	1	3	0	1
26 thru 50	32	0	1	8	0	1	5	0	1	13	1	2
51 thru 90	32	0	1	8	0	1	20	1	2	13	1	2
91 thru 150	32	0	1	32	1	2	20	1	2	20	2	3
151 thru 280	32	0	1	32	1	2	32	2	3	32	3	4
281 thru 500	32	0	1	50	2	3	50	3	4	50	5	6
501 thru 1,200	125	1	2	80	3	4	80	5	6	80	7	8
1,201 thru 3,200	125	1	2	125	5	6	125	7	8	125	10	11
3,201 thru 10,000	200	2	3	200	7	8	200	10	11	200	14	15
10,001 thru 35,000	200	2	3	315	10	11	315	14	15	315	21	22
Over 35,000	200	2	3	500	14	15	500	21	22	315	21	22

Where sample size is equal to or greater than lot size 100% inspect.

TABLE VII. Sampling Plan B

Lot Size	Sample Size	Acceptance Number
Under 10,000	5	0
10,000 to 50,000	10	0
50,001 to 100,000	15	0
Over 100,000	27	1

4.5.1 Examination of product - The nuts shall be examined for conformance to this specification and applicable approved standards with respect to material, workmanship, dimensions, design and construction, and finish.

4.5.1.1 Bearing surface - Bearing surface values shall be measured by means of a table squareness gage, with a seating surface diameter equal to or greater than the base diameter of the nut being examined, in conjunction with a feeler gage, with a class 3A threaded member at engagement in the locking device, and turned finger tight.

MIL-N-8984

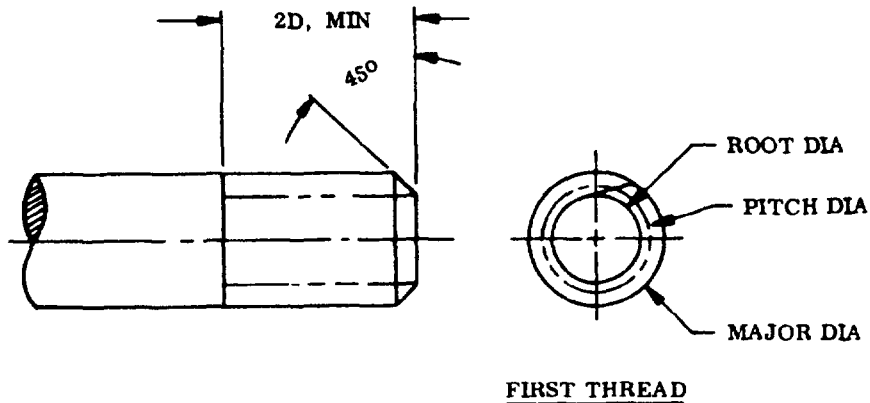
**DETAILS:****MATERIAL:** STEEL**HARDNESS:** HEAT TREATED TO ROCKWELL C60 to 64.**THREADS:** THE THREAD FORM SHALL CONFORM TO THAT SHOWN IN MIL-S-8879. THE THREADS SHALL BE RIGHT HAND. THE THREAD DIMENSIONS SHALL BE AS SHOWN IN TABLE XI.**SURFACE ROUGHNESS:** 20 MICRONS MAXIMUM IN ACCORDANCE WITH ANSI (USAS) B46.1-1962.

THE MANDREL END SHALL HAVE A 45-DEGREE CHAMFER EXTENDING BELOW THE ROOT DIAMETER. THE RESULTING SHARP FEATHER EDGE OF THE INCOMPLETE THREAD SHALL BE REMOVED BY STONING.

NOTE: LUBRICANT SHALL BE USED ONLY WHEN THE MANDREL IS USED WITH CORROSION-RESISTING STEEL NUTS.

FIGURE 1. Mandrel

MIL-N-8984

4.5.2 Axial strength - The nuts shall be assembled on test bolts as specified in table VIII, having minimum grip length equal to three times the bolt diameter, and subjected to the axial strength load specified in table I. Test method and fixtures shall be in accordance with Test 8, MIL-STD-1312. The nuts shall support the axial strength load without rupture. For qualification, apply load until nut or bolt failure occurs. For quality conformance, tests may be discontinued after minimum load has been achieved. Bolt failure below the rated axial strength of the nut due to defective bolt is not cause for rejection. In the event of such bolt failure, this test shall be repeated.

4.5.2.1 Hardness - The nuts shall be tested for hardness in accordance with Test 6, MIL-STD-1312.

4.5.3 Torque -

4.5.3.1 Wrench torque - The nuts shall be installed on test bolts as specified in table VIII with a steel test fixture in accordance with figure 2 and torqued to the wrench torque test values specified in table I. The nuts shall then be removed and reinstalled to this torque fourteen additional times. Wrenches shall be of the socket type conforming to MIL-W-8982. Deformation which interferes with the proper application and removal of the nut with the wrench is sufficient cause for rejection.

4.5.3.2 Torque effectivity - room temperature - The nuts shall be installed on test bolts as specified in table VIII with test fixtures in accordance with figure 2 and torque to the seating torque values specified in table III. The nuts shall then be removed and reinstalled (seated) fourteen additional times. The maximum locking torque and minimum breakaway torques for the 1st, 7th and 15th cycles shall be recorded. The minimum breakaway torque shall be that torque required to start relative motion, between the nut and bolt after the nut has been unseated and backed off one-half turn.

4.5.3.2.1 Torque effectivity - after 450° bake - The nuts shall be installed on test bolts as specified in table VIII with test fixtures in accordance with figure 2 and torqued to the seating torque values specified in table III. The assemblies shall then be baked for one hour at 450° F (-0° + 25°) and cooled to room temperature. The nuts shall then be removed and reinstalled (seated and baked) four additional times. The maximum locking torque and minimum breakaway torques for the 1st and 5th cycles shall be recorded. The minimum breakaway torque shall be that torque required to start relative motion, between the nut and bolt, after the nut has been unseated and backed off one-half turn.

TABLE VIII. *Type of Test Bolt or Stud

Type	Test	Reference
II	Axial Strength, Room Temperature	(4.5.2)
II	Stress Durability	(4.5.5)
II	Torque Effectivity, Room Temperature (Locking Element)	(4.5.3.2)
II	Wrench Torque	(4.5.3.1)
I	Locking Torque	(4.5.3.3)
III	Permanent Set	(4.5.3.4)
II	Torque Effectivity, 450° F (Locking Element)	(4.5.3.2.1)
II	Stress Corrosion	(4.5.6)
I	Accelerated Vibration	(4.5.4)

*Type: 1/I Rolled threads in accordance with MIL-S-8879 thread form, having 160 KSI (minimum) strength level. If bolts are used, head configuration is optional.

1/II Rolled threads in accordance with MIL-S-8879 thread form, having 260 KSI (minimum) strength level. If bolts are used, head configuration is optional.

III A. Maximum Stud - Cadmium plated 125 KSI (minimum) strength level with rolled threads in accordance with MIL-S-8879, except that the pitch diameter shall be established at 75%, +.0000-.0004 of the tolerance range of class 3A, above the minimum pitch diameter subject to check with functional pitch diameter tri-roll gages (see table XI).

B. Minimum Mandrel - In accordance with figure 1. Threads shall conform to table XI. It shall be checked with pitch diameter tri-roll gages.

1/ Test bolts specified in this table are for referee purposes. Bolts or threaded studs may be used for routine testing. Threads may be rolled before or after heat treatment and shall be cadmium plated.

MIL-N-8984

Test Fixture For Torque
Effectivity and Wrench
Torque.

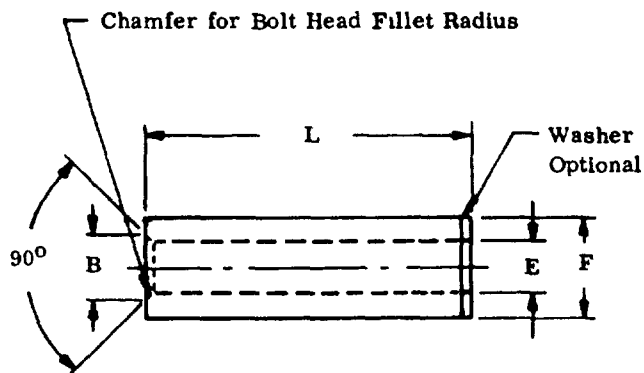

Ends of bushing and bushing plus washer to be flat and parallel within .002. Surface texture of ends: 32 microinches per ANSI B46.1

Material 8740 steel per
MIL-S-6049 or
AMS6322 or 43-0
steel per
MIL-S-5000

Heat Treat. Rockwell C45 to
51

Finish Cadmium Plate per
QQ-P-416 Type II,
Class 2, except
embrittlement
test per QQ-P-416
does not apply

FIGURE 2. Test Fixture

TABLE IX. Dimensions for Torque Test Bushing Assembly

Nut Nominal Thread Size (Ref.)	B Diameter ±.005	E Diameter +.000 -.010	F Diameter Minimum	L ±.010 (a)
.1900-32	.285	.205	Diameter of Nut Base or Twice the Diameter of the Bolt Whichever is Greater	2.125
.2500-28	.345	.265		2.125
.3125-24	.407	.327		2.125
.3750-24	.502	.390		2.125
.4375-20	.564	.452		2.625
.5000-20	.627	.515		2.625
.5625-18	.689	.577		2.625
.6250-18	.783	.640		2.875
.7500-16	.908	.765		2.938
.8750-14	1.033	.890		2.938
1.0000-12	1.158	1.015		3.188
1.1250-12	1.283	1.140	3.188	
1.2500-12	1.440	1.265	3.188	
1.3750-12	1.565	1.390	3.188	
1.5000-12	1.690	1.565	3.188	

This table applies to figure 2.

(a) Length "L" may include one washer of equal material and hardness.
Length "L" may vary to accommodate other bolt lengths - see
table 11 note b.

4.5.3.3 Locking torque - The nuts shall be installed and removed on test bolts, as specified in table VIII, one time recording maximum locking torque and minimum breakaway torque during the one cycle.

4.5.3.4 Permanent set - Permanent set shall be subjecting the nut at room ambient temperature, to one complete installation and removal cycle on a maximum stud in accordance with table VIII and then repeating the test cycle with the same clean nut on a minimum pitch mandrel, in accordance with table VIII. Three of the nuts submitted shall be subjected to this test.

4.5.4 Vibration - Sample nuts with bolts of the size and quantities specified in table X shall be vibrated in accordance with Test 7, MIL-STD-1312. Vibration life, for each lot of five specimens tested in accordance with Test 7, MIL-STD-1312, of less than 45,000 cycles shall be cause for rejection.

TABLE X. Vibration Requirements

Nut Size	Bolt Grip (Inch)	Test 7, MIL-STD-1312 Bolts and Nuts Required (Min. of each) 450° F
10-32	1.125	10
1/4-28	1.188	10
5/16-24	1.188	10
3/8-24	1.188	10
7/16-20	1.188	10
1/2-20	1.188	10
9/16-18	1.188	10
5/8-18	1.188	10

4.5.4.1 Vibration tests on nuts larger than 5/8-inch size are waived, provided that 5/8-inch nuts and smaller of the same type and design of locking device have satisfactorily passed the vibration test.

4.5.4.2 Preparation for vibration test to Test 7, MIL-STD-1312 -

4.5.4.3 Accelerated vibration - The nuts shall be assembled in accordance with figure 2, of Test 7, MIL-STD-1312, with bolts and torque values as specified in table X. The nuts shall then be removed and reinstalled to this torque four additional times before being vibrated.

MIL-N-8984

4.5.4.4 Baking of test specimens - Half of the nuts shall be assembled on the appropriate bolts and baked for six hours at 450° F. The baked specimens shall be allowed to cool slowly in air to room temperature. The nuts shall then be removed and reinstalled to torque values specified in table X for four additional times before being vibrated.

4.5.4.5 Method - Use procedure of Test 7, MIL-STD-1312.

4.5.4.5.1 Determination shall be made throughout the test to guarantee that assembly is traversing the entire length of the slots in the test fixture. The test shall be run for 45,000 cycles except that it shall be stopped prior to the completion of the 45,000 cycles in the event a nut becomes disassembled from the bolt. The nut samples shall be examined under 10X magnification for cracks.

4.5.4.5.2 The nuts shall be considered to have failed to pass the vibration test under the following conditions:

(a) If any structural failure, such as broken segments, locking inserts falling out, or cracks occurring in the nuts during the test, provided failure is not the result of failure of the bolt.

(b) If any nut comes completely off the bolt or can be turned completely on or off the bolt with the fingers during or after completion of 45,000 cycles.

(c) If relative rotation between any nut and bolt exceeds 360 degrees.

4.5.5 Stress durability - Test in accordance with Test 14, MIL-STD-1312 as specified in table VIII and torqued until the bolt elongates the amount specified in table II. The assemblies shall then be baked for 96 hours at 450° F (-0° +25°) and cooled to room temperature. After removing nuts, polish bearing surface of nuts and examine, at 10X to 50X magnification, for cracks.

4.5.6 Stress corrosion - Test in accordance with Test 9, MIL-STD-1312 The nuts shall be installed on test bolts as specified in table VIII and torqued until the bolt elongates the amount specified in table II. After 500 hours of alternate immersion, the parts shall be disassembled and the nut bearing surface shall be polished and examined, at 10X to 50X magnification, for cracks.

4.5.7 Discontinuities - The presence of discontinuities, such as laps, seams, and inclusions shall be determined by magnetic particle inspection in accordance with MIL-I-6868 on 100 percent of the nuts. Such inspection shall

be performed on finished nuts, free of lubrication, subsequent to any processing operations which could adversely affect the part. The magnetizing field shall be normal to the longitudinal axis of the nut. Magnetic indications in themselves shall not be cause for rejection. Sample nuts with indications in other locations may be sectioned and measured microscopically to determine conformance to the requirements specified in table IV. Nuts shall not be dyed or marked for identification of magnetic particle inspection.

4.5.8 Suitability of lubricant coatings -

4.5.8.1 Effect of the coating on the ability of cadmium plating to prevent galvanic corrosion - Lubricant coated and unlubricant coated "scratch panels", made of the same material as the finished fastener product, and cadmium plated in accordance with QQ-P-416, shall be scratched through to the base metal. The unlubricated panel shall be cadmium plated in accordance with type II, class 2 of QQ-P-416. These panels shall be subjected to salt spray test in accordance with Test 1, MIL-STD-1312. After exposure, no significant difference in corrosion shall be found when a comparison is made between the panels with the lubricant and the unlubricated panels.

4.5.8.2 Effect of the coating on structural materials in contact with the fastener - Corrosion test specimens will be panels with four test fasteners per panel. Two fasteners of each specimen panel shall be cadmium plated in accordance with type II, class 2 of QQ-P-416 without lubricant coating. The other two fasteners shall be plated in accordance with the applicable standard and shall be lubricant coated. Duplicate specimen sets of the following alloys and finishes shall be subjected to salt spray test in accordance with Test 1, MIL-STD-1312.

(a) Bare 7075-T6 and 2024-T6 aluminum-alloy surfaces treated in accordance with MIL-C-5541 and anodized in accordance with MIL-A-8625.

(b) Clad 7075-T6 and 2024-T6 aluminum alloy

(c) Titanium alloy. (6AL-4V)

(d) Corrosion-resistant steel. (AISI 300 Series)

(e) Magnesium alloy wherein the fasteners are insulated from the magnesium in accordance with MIL-F-7179.

M... -8984

TABLE XI. Thread Dimensions for Maximum Stud and Minimum Mandrel for Permanent Set Test

Maximum 3A Stud			Minimum 3A Mandrel			
Size	Pitch Diameter		+0.0000 -0.0004 Major Diameter	+0.0000 -0.0004 Pitch Diameter	Tolerance in lead (per inch)	Tolerance on half angle of thread (in minutes)
	Maximum	Minimum				
10-32	.1691	.1687	.1840	.1674	±.0003	±15
1/4-28	.2261	.2257	.2435	.2243	±.0003	±15
5/16-24	.2847	.2843	.3053	.2827	±.0003	±15
3/8-24	.3471	.3467	.3678	.3450	±.0003	±15
7/16-20	.4042	.4038	.4294	.4019	±.0003	±15
1/2-20	.4667	.4663	.4919	.4643	±.0003	±15
9/16-18	.5255	.5251	.5538	.5230	±.0003	±10
5/8-18	.5880	.5876	.6163	.5854	±.0003	±10
3/4-16	.7084	.7080	.7406	.7056	±.0003	±10
7/8-14	.8275	.8271	.8647	.8245	±.0003	±10
1 -12	.9448	.9444	.9886	.9415	±.0003	±10
1-1/8-12	1.0697	1.0693	1.1136	1.0664	±.0003	±10
1-1/4-12	1.1947	1.1943	1.2386	1.1913	±.0003	±10
1-3/8-12	1.3197	1.3193	1.3636	1.3162	±.0003	±10
1-1/2-12	1.4447	1.4443	1.4886	1.4411	±.0003	±10

After exposure, the specimens shall be disassembled and no significant difference in corrosion shall be found on either the fasteners or panel faying surface when a comparison is made between the fasteners with lubricant and fasteners without lubricant

4.5.8.3 Behavior of coating with paint - Corrosion test specimens shall be of aluminum alloy, similar to those specified in 4.5.8.2, and painted including the fasteners with wash primer zinc-chromate primer system in accordance with MIL-F-7179. These specimens shall be subjected to salt spray test in accordance with Test 1, MIL-STD-1312. After exposure, no significant difference in corrosion, blistering, or loss of adhesion of the paint shall be found when a comparison is made between the fasteners with lubricant and fasteners without lubricant.

4.5.8.4 Effect of coating on sealing materials - Corrosion test specimens shall be of aluminum alloy similar to those specified in 4.5.8.2, except that MIL-S-8802 and MIL-S-7502 fuel tank sealant material shall be applied to the fasteners. A specimen panel shall be prepared for each sealant material. Before the application of the sealant material, the fasteners and panels shall be cleaned by scrubbing and rinsing with solvent formulated in accordance with table XII. After rinsing, and while still wet, the specimens shall be wiped dry with clean, nonoily wiping cloths or tissue. These specimens shall be subjected to salt spray test in accordance with Test 1, MIL-STD-1312.

After exposure, no significant difference in loss of adhesion or degradation of sealant material shall be found when a comparison is made between the fasteners with lubricant and fasteners without lubricant.

TABLE XII. Formulation of Cleaner

Ingredient	Specification	Percent by Volume
Aromatic Petroleum Naphtha	TT-N-97, Type I, Grade B	50
Ethyl Acetate	TT-E-751	20
Methyl-ethyl-ketone	TT-M-261	20
Isopropyl alcohol	TT-I-735	10

4.5.8.5 Effect of coating on stress corrosion resistance of fasteners - The lubricated threaded fastener shall be scratched through to the base metal. Torque shall be applied against the aluminum-alloy panels to induce 90,000 pounds per square inch in mating bolt. The assembly shall be salt spray tested in accordance with Test 1, MIL-STD-1312. After exposure, the lubricated fastener shall not have any cracks which can be determined by visual inspection under 10X magnification.

MIL-N-8984

4.6 Preservation, packaging, packing and marking - Preparation for delivery shall be inspected for conformance to section 5.

5. PREPARATION FOR DELIVERY

5.1 Preservation and packaging - Packaging shall be level A or C as specified (see 6.2).

5.1.1 Level A - Unless otherwise specified, self-locking nuts shall be preserved and packaged in accordance with Method III of MIL-P-116. If the net contents exceed 5 pounds, nuts shall be packaged within interior containers conforming to PPP-B-566, PPP-B-665, or PPP-B-676.

5.1.2 Level C - Self locking nuts shall be preserved and packaged to afford adequate protection against deterioration and physical damage during shipment from supply source to the first receiving activity for immediate use.

5.2 Packing - Packing shall be level A, B or C as specified (see 6.2).

5.2.1 Level A - Self locking nuts shall be packed in overseas, class or type shipping containers conforming to PPP-B-601 or PPP-B-621. Insofar as practicable, containers shall be of uniform shape and size, be of minimum cube and tare consistent with the protection required and contain identical quantities. The gross weight of each pack shall be limited to approximately 200 pounds. Containers shall be provided with a case liner conforming to MIL-L-10547 and shall be sealed in accordance with the appendix thereto. Containers shall be closed and strapped in accordance with the applicable specification or appendix thereto.

5.2.2 Level B - Self locking nuts shall be packed in domestic-type shipping containers conforming to PPP-B-601, PPP-B-621, or PPP-B-636, class weather-resistant. Insofar as practicable, containers shall be of uniform shape and size, be of minimum cube and tare consistent with the protection required and contain identical quantities. Containers shall be closed and strapped in accordance with the applicable container specification or appendix thereto.

5.2.3 Level C - Self locking nuts, packaged as specified in 5.1.2, shall be packed to afford adequate protection against damage during direct shipment from supply source to the first receiving activity for immediate use. Containers shall comply with the Uniform Freight Classification Rules or regulations of other common carriers as applicable to the mode of transportation.

MIL-N-8984

5.3 Marking of shipments - In addition to any special requirements of the contract or order, shipments shall be marked in accordance with MIL-STD-129.

6. NOTES

6.1 Intended use - The nuts are intended for use in airframes and airborne mechanical systems in combination with high fatigue 260 KSI bolt applications where the maximum temperatures do not exceed 450⁰ F.

6.2 Ordering data - Procurement documents should specify:

- (a) Title, number, and data of this specification.
- (b) MS Part Number (see 3.1).
- (c) Applicable levels of packaging and packing (see 5.1 and 5.2).

6.3 Qualification - With respect to products requiring qualification, awards will be made only for such products as have, prior to the time set for opening of bids, been tested and approved for inclusion in the applicable Qualified Products List whether or not such products have actually been so listed by that date. The attention of the suppliers is called to this requirement, and manufacturers are urged to arrange to have the products that they propose to offer to the Federal Government, tested for qualification in order that they may be eligible to be awarded contracts or orders for the products covered by this specification. The activity responsible for the Qualified Products List is the Naval Air System Command, Navy Department, Washington, D.C. 20360. However, information pertaining to qualification of products may be obtained from the Naval Air Development Center, Code (MAEM) Warminster, Pennsylvania, 18974.

6.3.1 Qualification tests will be authorized only upon presentation of certified test reports indicating that the nuts conform to this specification (see 4.3.3) and the applicable MS standard or a standard approved by the activity responsible for qualification.

6.4 Definitions applicable to the tests under this specification -

6.4.1 Installed - A nut is considered installed when a minimum of two thread pitches plus the chamfer of the male thread extend beyond the top of the nut.

6.4.2 Removal cycle - The removal cycle is considered complete when the locking device is disengaged.

MIL-N-8984

6.4.3 Crack - A crack is a clear break passing through the grain or grain boundary with inclusion of foreign elements.

6.4.4 Minimum breakaway torque - The minimum breakaway torque is that torque required to start nut rotation from a fixed position during a removal cycle with no load on the base of the nut.

6.4.5 Maximum locking torque - The maximum locking torque is the highest self locking torque encountered in any installation or removal cycle with no load on the base of the nut.

Custodians

Navy - AS
Air Force - 11
Army - AV

Preparing Activity.

Navy - AS
(Project No. 5310-0721)

Reviewer Activity:

Navy - AS
Air Force - 11
Army - AV, AT DSA-IS

User Activity

Navy - AS
Air Force - 11
Army - MI

Review/user information is current as of the date of this document. For future coordination of changes to this document, draft circulation should be based on the information in the current DoD Index of Specifications and Standards

SPECIFICATION ANALYSIS SHEET		Form Approved Budget Bureau No 22-R255
<p>INSTRUCTIONS This sheet is to be filled out by personnel, either Government or contractor, involved in the use of the specification in procurement of products for ultimate use by the Department of Defense. This sheet is provided for obtaining information on the use of this specification which will insure that suitable products can be procured with a minimum amount of delay and at the least cost. Comments and the return of this form will be appreciated. Fold on lines on reverse side, staple in corner, and send to preparing activity. Comments and suggestions submitted on this form do not constitute or imply authorization to waive any portion of the referenced document(s) or serve to amend contractual requirements.</p>		
<p>SPECIFICATION MIL-N-8984 NUT, SELF-LOCKING, STEEL, 260 KSI F_{tu}, 450°F</p>		
<p>ORGANIZATION</p>		
<p>CITY AND STATE</p>		<p>CONTRACT NUMBER</p>
<p>MATERIAL PROCURED UNDER A <input type="checkbox"/> DIRECT GOVERNMENT CONTRACT <input type="checkbox"/> SUBCONTRACT</p>		
<p>1 HAS ANY PART OF THE SPECIFICATION CREATED PROBLEMS OR REQUIRED INTERPRETATION IN PROCUREMENT USE? A GIVE PARAGRAPH NUMBER AND WORDING</p>		
<p>B RECOMMENDATIONS FOR CORRECTING THE DEFICIENCIES</p>		
<p>2 COMMENTS ON ANY SPECIFICATION REQUIREMENT CONSIDERED TOO RIGID</p>		
<p>3 IS THE SPECIFICATION RESTRICTIVE? <input type="checkbox"/> YES <input type="checkbox"/> NO (If "yes", in what way?)</p>		
<p>4. REMARKS (Attach any pertinent data which may be of use in improving this specification. If there are additional papers, attach to form and place both in an envelope addressed to preparing activity.)</p>		
<p>SUBMITTED BY (Printed or typed name and activity - Optional)</p>		<p>DATE</p>

DD FORM 1426
1 JAN 60

REPLACES EDITION OF 1 OCT 64 WHICH MAY BE USED

FOLD

DEPARTMENT OF THE NAVY

Naval Air Engineering Center
Philadelphia, Pennsylvania 19112

POSTAGE AND FEES PAID
NAVY DEPARTMENT

OFFICIAL BUSINESS

Engineering Specifications and Standards Department (Code X)
Naval Air Engineering Center
Philadelphia, Pennsylvania 19112

NOTICE OF
VALIDATION

INCH - POUND
MIL-N-8984
NOTICE 1
31 July 1989

MILITARY SPECIFICATION SHEET

NUT, SELF-LOCKING, STEEL, 260 KSI FTU, 450°F

MIL-N-8984, dated 28 January 1972, has been reviewed and determined to be valid for use in acquisition.

Custodians:

Army - AV
Navy - AS
Air Force - 99

Preparing Activity:

Navy - AS

AMSC N/A

FSC 5310

DISTRIBUTION STATEMENT A Approved for public release; distribution is unlimited.