

INCH-POUND

MIL-C-172C
AMENDMENT 6
15 February 2001
SUPERSEDING
AMENDMENT 2
20 October 1966

MILITARY SPECIFICATION

CASES; BASES, MOUNTING; AND MOUNTS VIBRATION (FOR
USE WITH ELECTRONIC EQUIPMENT IN AIRCRAFT)

INACTIVE FOR NEW DESIGN AFTER 18 SEPTEMBER 1996

This amendment forms a part of MIL-C-172C, dated 9 December 1958, and is approved for use by all Departments and Agencies of the Department of Defense.

The USAF Interim Amendments 3, 4, and 5; dated 16 Jan 1970, 1 Oct 1971, and 14 Feb 1977 respectively, were canceled by Notice 1, dated 15 January 1995.

PAGE 3

* 3.2: Delete and substitute:

“3.2 First article inspection. When specified (see 6.2), a sample shall be subjected to first article inspection in accordance with 4.4.”

PAGE 5

3.5.2.1: Delete and substitute:

“3.5.2.1 Locking devices.

“3.5.2.1.1 Safety wiring. Safety wiring, passing through holes provided for that purpose in the thumb nuts or wing nuts of the fastener assembly and in the mounting base, shall be used to prevent loosening thereof under vibration.

MIL-C-172C
AMENDMENT 6

“3.5.2.1.2 Automatic locking devices. For all Air Force procurement only automatic locking devices shall be use in all cases, bases, and mounts to prevent loosening thereof under vibration. Dimensions shall be within the envelope shown in figure 6. For Army and Navy procurement automatic looking may be used provided they are specified by the procuring activity.”

Insert figure 6:

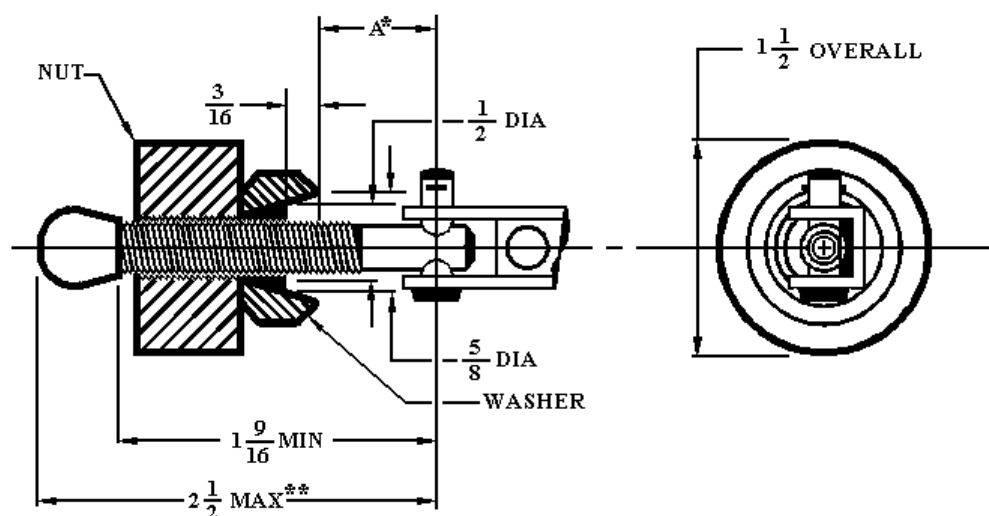

* CLEARANCE ON OPEN OR EXTENDED POSITION 1-3/8 MINIMUM FOR DIMENSION A

** THIS DIMENSION SHALL BE NO GREATER THAN NECESSARY TO MEET THE MINIMUM CLEARANCE OF DIMENSION A

MATERIAL: CORROSION-RESISTANT STEEL

ALL DIMENSIONS IN INCHES

FIGURE 6. Automatic locking device.

MIL-C-172C
AMENDMENT 6

- * 4.1(b)1: Delete “Qualification” and substitute “First article.”

PAGE 11

- * 4.4: Delete “Qualification” and substitute “First article.”

Table I: Delete “Qualification” and substitute “First article.”

PAGE 18

6.2: Insert the following:

“(l) For mounting bases, the type of locking device shall be specified (see 3.5.2.1).”

- * “(m) When first article is required (see 3.2).”

PAGE 19

- * 6.3: Delete.

PAGE 22

30.2(a): Insert the following:

“5. If the submission includes front clamp assemblies equipped with automatic locking devices, and further includes a tray and vibration mounts which have already been tested together as a mounting base with conventional front clamp assemblies, as a result of a previous submission under the provisions of 30.2, first article inspection of the base will consist only of visual and dimensional inspection, salt spray, and shock (4.6.5.3 only).”

NOTE: The margins of this amendment are marked with asterisks to indicate where changes from the previous amendment were made. This was done as a convenience only and the Government assumes no liability whatsoever for any inaccuracies in these notations. Bidders and contractors are cautioned to evaluate the requirements of this document based on the entire content irrespective of the marginal notation and relationships to the last previous amendment.

MIL-C-172C
AMENDMENT 6

Custodians:

Army - CR
Navy - AS
Air Force - 11

Preparing activity:

Navy - AS

(Project 5975-1336)

Review activities:

Army - AR, AV, MI
Air Force - 99
DLA - GS