

INCH-POUND

MIL-PRF-49142B
27 October 2004
SUPERSEDING
MIL-PRF-49142A
27 November 1996

PERFORMANCE SPECIFICATION

CONNECTOR, TRIAXIAL, RADIO FREQUENCY GENERAL SPECIFICATION FOR

This specification is approved for use by Department and Agencies of the Department of Defense.

1. SCOPE

1.1 Scope. This specification covers the general requirements and tests for radio frequency (RF), triaxial, connectors (see 6.1).

1.2 Classification. Connectors are of the following classes and Part or Identifying Number (PIN), as specified (see 3.1).

1.2.1 Classes. The class of connectors consists of the following:

- a. Class 1: A class 1 connector is a connector which is intended to provide superior RF performance at specified frequencies, and for which all RF characteristics are completely defined.
- b. Class 2: A class 2 connector is intended to provide mechanical connection within an RF circuit providing specified RF performance.

Comments, suggestions, or questions on this document should be addressed to Defense Supply Center Columbus, ATTN: VAI, P.O. Box 3990, Columbus OH 43218-3990 or email to RFConnectors@dsccl.dla.mil. Since contact information can change, you may want to verify the currency of this address information using the ASSIST Online database at <http://assist.daps.dla.mil>.

MIL-PRF-49142B

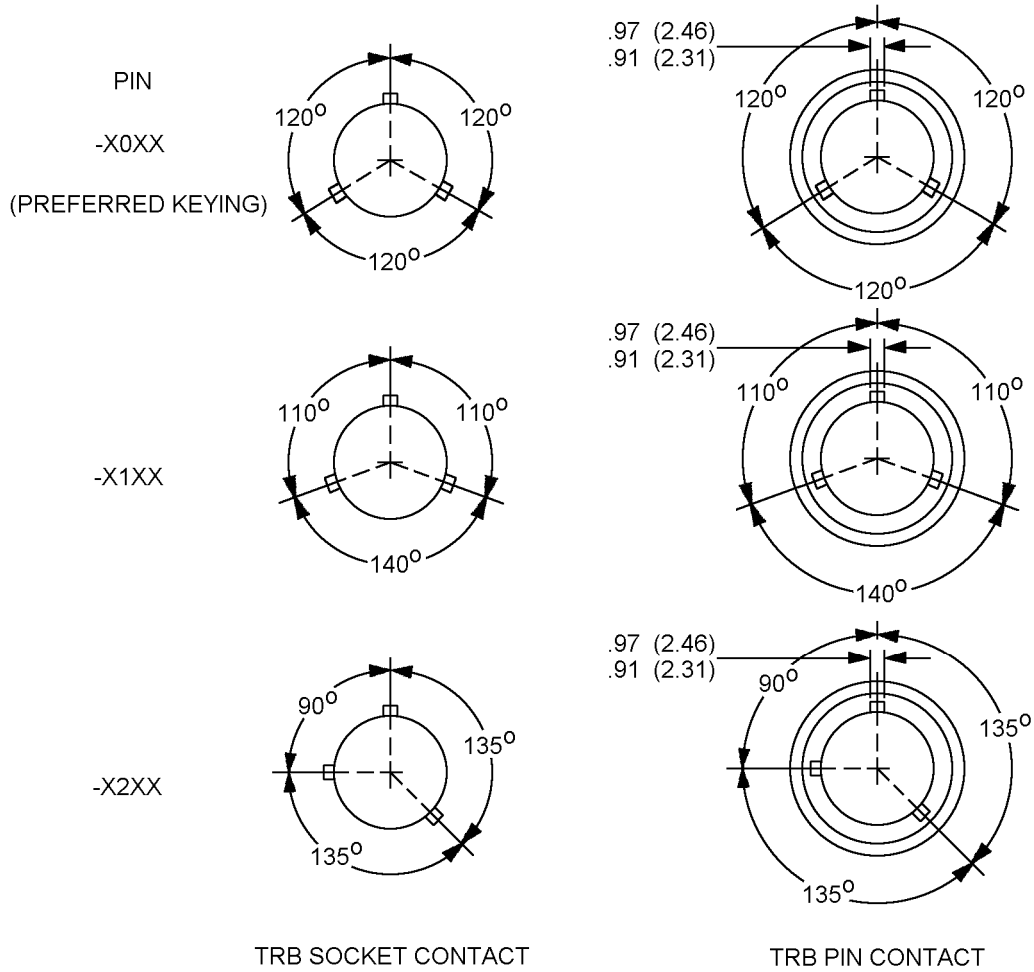

NOTES:

1. Bayonets are dimensioned in accordance with MIL-STD-348, unless otherwise specified.
2. All angle tolerances are $\pm 1^\circ$.

FIGURE 1. Keying configurations (TRB) only.

MIL-PRF-49142B

2. APPLICABLE DOCUMENTS

2.1 General. The documents listed in this section are specified in sections 3, 4, or 5 of this specification. This section does not include documents cited in other sections of this specification or recommended for additional information or as examples. While every effort has been made to ensure the completeness of this list, document users are cautioned that they must meet all specified requirements of documents cited in sections 3, 4, or 5 of this specification, whether or not they are listed.

2.2 Government documents.

2.2.1 Specifications, standards, and handbooks. The following specifications, standards, and handbooks form a part of this document to the extent specified herein. Unless otherwise specified, the issues of these documents are those cited in the solicitation or contract.

FEDERAL STANDARDS

FED-STD-H28 - Screw Thread Standards for Federal Services

COMMERCIAL ITEM DESCRIPTIONS

A-A-59588 - Rubber, Silicone

DEPARTMENT OF DEFENSE STANDARDS

MIL-STD-202 - Test Methods for Electronic and Electrical Component Parts

MIL-STD-348 - Radio Frequency Connector Interfaces for MIL-C-3643, MIL-C-3650, MIL-C-3655, MIL-C-25516, MIL-C-26637, MIL-PRF-39012, MIL-PRF-49142, MIL-PRF-55339, MIL-C-83517

MIL-STD-889 - Dissimilar Metals

MIL-STD-1285 - Marking of Electrical and Electronic Parts

(Copies of these documents are available online at <http://assist.daps.dla.mil/quicksearch/> or <http://assist.daps.dla.mil> or from the Standardization Documents Order Desk, 700 Robbins Avenue, Building 4D, Philadelphia, PA 19111-5094.)

2.3 Non-Government publications. The following documents form a part of this document to the extent specified herein. Unless otherwise specified, the issues of these documents are those cited in the solicitation or contract.

MIL-PRF-49142B

ASTM INTERNATIONAL

- ASTM A342 - Magnetic materials, Permeability of Feebly
- ASTM A484 - Standard Specification for General Requirements for Stainless Steel Bars, Billets, and Forgings
- ASTM A582 - Standard Specification for Free-Machining Stainless Steel Bars
- ASTM B16 - Standard Specification for Free-Cutting Brass Rod, Bar and Shapes for Use in Screw Machines
- ASTM B36 - Standard Specification for Brass Plate, Sheet, Strip, and Rolled Bar
- ASTM B88 - Standard Specification for Seamless Copper Water Tube
- ASTM B121 - Standard Specification for Leaded Brass Plate, Sheet, Strip, and Rolled Bar
- ASTM B139 - Phosphor Bronze Rod, Bar and Shapes
- ASTM B152 - Copper Sheet, Strip, Plate and Rolled Bar
- ASTM B488 - Gold for Engineering Uses, Electrodeposited Coatings of
- ASTM B194 - Standard Specification for Copper-Beryllium Alloy Plate, Sheet, Strip, and Rolled Bar
- ASTM B196 - Standard Specification for Copper-Beryllium Alloy Rod and Bar
- ASTM B197 - Standard Specification for Copper-Beryllium Alloy Wire
- ASTM B700 - Electrodeposited Coatings of Silver for Engineering Use
- ASTM D2116 - FEP Fluorocarbon Molding and Extrusion Materials
- ASTM D4894 - Polytetrafluoroethylene (PTFE), Grandular Molding and Ram Extrusion Materials
- ASTM D4895 - Standard Specification for Polytetrafluoroethylene (PTFE), Resin Produced from Dispersion

(Copies of these documents are available online at <http://www.astm.org> or from the ASTM International, 100 Barr Harbor Drive, Conshohocken, PA 19428-2959.)

AMERICAN NATIONAL STANDARDS INSTITUTE (ANSI)

- ANSI B46.1 - Surface Texture

(Copies of these documents are available online at <http://www.sae.org> or from the American National Standards Institute, 25 West 43 Street, 4th Floor, New NY 10036.)

ELECTRONIC INDUSTRIES ALLIANCE (EIA)

- EIA 364 - Electrical Connectors/Socket Test Procedures Including Environmental Classifications

(Copies of these documents are available online at <http://www.eia.org> or from the Electronic Industries Alliance, Technology Strategy & Standards Department, 2500 Wilson Boulevard, Arlington, VA 22201.)

SOCIETY OF AUTOMOTIVE ENGINEERS (SAE)

- SAE-AMS-QQ-P-35 - Passivation Treatments for Corrosion-Resistant Steel
- SAE-AMS-QQ-N-290 - Nickel Plating (Electrodeposited)

(Copies of these documents are available online at <http://www.sae.org> of from the Society of Automotive Engineers, 400 Commonwealth Drive, Warrendale, PA 15096-001.)

MIL-PRF-49142B

2.4 Order of precedence. In the event of a conflict between the text of this document and the references cited herein (except for related specification sheets), the text of this document takes precedence. Nothing in this document, however, supersedes applicable laws and regulations unless a specific exemption has been obtained.

3. REQUIREMENTS

3.1 Specification sheets. The individual item requirements shall be as specified herein and in accordance with the applicable specification sheets. In the event of any conflict between the requirements of this specification and specification sheets, the latter shall govern.

3.2 Qualification. Connectors furnished under this specification shall be products that are authorized by the qualifying activity for listing on the applicable qualified products list before contract award (see 4.4 and 6.3.)

3.3 Critical interface material. Material shall be as specified herein (see table I). If materials other than those specified are used, the contractor shall certify to the qualifying activity that the substitute material enables the connectors to meet the requirements of this specification. Acceptance or approval of any constituent material shall not be construed as a guaranty of the acceptance of the product. When a definite material is not specified a material shall be used which will enable the connector to meet the requirements of this specification.

TABLE I. Materials.

Component material	Applicable specification
Phosphor bronze	ASTM B139
Soft copper	ASTM B152
Copper	ASTM B88
PTFE fluorocarbon	ASTM D4894 and ASTM D4895
FEP fluorocarbon	ASTM D2116
Silicon rubber	A-A-59588

3.3.1 Critical interface materials and finish. Unless otherwise specified (see 3.1), connector center contacts and bodies shall be plated in the following manner in order to meet the requirements of this specification and avoid detrimental interactions between dissimilar metals.

3.3.1.1 Recycled, recovered, or environmentally preferable materials. Recycled, recovered, or environmentally preferable materials should be used to the maximum extent possible, provided that the material meets or exceeds the operational and maintenance requirements, and promotes economically advantageous life cycle costs.

3.3.1.2 Center contacts. The male pin shall be plated to a minimum gold thickness of 50 micro inches (1.27 μm) in accordance with ASTM B488, type II code C, class 1.27, over 50 micro inches (1.27 μm) minimum of nickel in accordance with SAE-AMS-QQ-N-290, class 1, measured anywhere along the mating surface, for all series. The socket contact shall be plated to a minimum of 50 micro inches (1.27 μm) of gold in accordance with ASTM B488, type II, code C, class 1.27, over 50 micro inches (1.27 μm) of nickel in accordance with SAE-AMS-QQ-N-290, class 1, including the I.D., measured at a depth of .040 inch (1.01 mm) minimum. The plating on non-significant surfaces in the I.D. shall be of sufficient thickness to ensure plating continuity and uniform utility and protection. This plating may consist of an underplate only. A silver underplate shall not be permitted.

MIL-PRF-49142B

3.3.1.3 Connector bodies. All brass bodied connectors in accordance with ASTM B16, ASTM B36 or ASTM B121 shall be silver plated in accordance with ASTM B700 to a minimum thickness of 0.000200 inch (0.005 mm) over a copper underplate or nickel plated to a minimum thickness of .000200 inch (0.005 mm) as defined in the PIN on the individual specification sheet. All corrosion resistant steel bodied connectors in accordance with ASTM A484 or ASTM A582 shall be passivated in accordance SAE-AMS-QQ-P-35, unless otherwise specified (see 3.1). The requirements of MIL-STD-889 must be met in 3.3.1.

3.3.2 Dissimilar metals. Dissimilar metals between which an electromotive couple may exist shall not be placed in contact with each other. Reference is made to MIL-STD-889 for definition of dissimilar metals.

3.3.3 Nonmagnetic materials. All parts (except hermetic sealed connectors) shall be made from materials which are classed as nonmagnetic (see 3.8).

3.3.4 Spring members. Unless otherwise specified (see 3.1), center contact spring members shall be made of copper beryllium in accordance with ASTM B194, ASTM B196, and ASTM B197.

3.4 Configuration and features. Connectors shall be of the configuration and physical dimensions specified (see 3.1).

3.4.1 Engineering parameters. The parameters of nominal impedance, voltage rating, frequency range and temperature range shall be as specified (see 3.1).

3.4.2 Mating (visual indication). When applicable (see 3.1), a visual means shall be provided to indicate when two mating connectors are properly mated.

3.4.3 Screw threads. Screw threads shall be in accordance with FED-STD-H28 unless otherwise specified (see 3.1).

3.4.4 Connector interfaces. Connector interfaces shall be in accordance with MIL-STD-348 unless otherwise specified (see 3.1).

3.5 Force to engage/disengage (see 4.6.2).

3.5.1 Bayonet and threaded types. When tested as specified in 4.6.2.1, the torque necessary to completely couple or uncouple the connectors shall not exceed that specified (see 3.1). Also the longitudinal force necessary to initiate the engaging or disengaging cycle shall not exceed that specified (see 3.1).

3.5.2 "Push on" connector types. When tested as specified in 4.6.2.2, the forces necessary to fully engage or disengage the connectors shall not exceed that specified (see 3.1).

3.6 Coupling proof torque (threaded types only). When connectors are tested as specified in 4.6.3, the coupling mechanism shall not be dislodged and the connector shall meet the requirements of 3.5.1. The interface dimensions of the connectors shall remain as specified (see 3.4.4).

3.7 Mating characteristics. When connectors are tested as specified in 4.6.4, the mating dimensions shall be gaged as specified (see 3.1) and the dimensions shall remain within the specified tolerances (see 3.1).

3.8 Permeability of nonmagnetic materials. When connectors (except hermetic sealed) are tested as specified in 4.6.5, the permeability (μ) shall be less than 2.0.

MIL-PRF-49142B

3.9 Hermetic seal (pressurized connectors). When connectors are tested as specified in 4.6.6, the leakage rate shall not exceed that specified (see 3.1).

3.10 Leakage (pressurized connectors). When connectors are tested as specified in 4.6.7, there shall be no leakage as detected by escaping air bubbles.

3.11 Insulation resistance. When connectors are tested as specified in 4.6.8, the insulation resistance shall not be less than 5.000 megohms (M Ω) minimum. Following the environmental tests insulation resistance shall not change from the initial requirement.

3.12 Conductor retention. When all class 1 and class 2 connectors are tested (when applicable see 3.1) as specified in 4.6.9, the center conductor must not be displaced from the specified interface dimensions in the uncabled connector by the application of the specified axial force (see 3.1) in either direction.

3.13 Salt spray (corrosion). Unless otherwise specified (see 3.1), connectors shall be tested as specified in 4.6.10. There shall be no exposure of the base metal on the interface or mating surface, and they shall meet the requirements of 3.5.1 or 3.5.2 as applicable. Following the test, connectors shall meet the requirements of 3.11.

3.14 Dielectric withstanding voltage. When connectors are tested as specified in 4.6.11, there shall be no evidence of breakdown.

3.15 Vibration, high frequency. When the cabled (or wired, as applicable) connector is tested as specified in 4.6.12, there shall be no electrical interruptions exceeding 1 microsecond (μ s), unless otherwise specified (see 3.1). There shall be no evidence of visual mechanical damage after the test.

3.16 Shock (specified pulse). When the cabled (or wired, as applicable) connector is tested as specified in 4.6.13, there shall be no electrical interruptions exceeding 1 microsecond (μ s), unless otherwise specified (see 3.1). There shall be no evidence of visual or mechanical damage after the test.

3.17 Thermal shock. When connectors are tested as specified in 4.6.14, there shall be no evidence of visual mechanical damage to the connector and it shall meet the dielectric withstanding voltage requirements (see 3.14).

3.18 Moisture resistance. Unless otherwise specified (see 3.1), connectors shall be tested as specified in 4.6.15 and there shall be no evidence of damage. Insulation resistance shall be as specified in 3.11.

3.19 Conductor resistance. When connectors are tested as specified in 4.6.16, the conductor resistance of the center conductor, immediate conductor, and outer conductor to body shall be as specified (see 3.1).

3.20 Corona level. When connectors are tested as specified in 4.6.17, at the altitude and voltage specified (see 3.1), there shall be no evidence of sustained corona discharge.

3.21 RF high potential withstanding voltage. When connectors are tested as specified in 4.6.18, there shall be no breakdown, and the leakage current specified shall not be exceeded (see 3.1).

3.22 Cable retention force. When applicable (see 3.1) connectors shall be tested as specified in 4.6.19, and there shall be no evidence of mechanical failure, loosening, rupture, or discontinuity.

MIL-PRF-49142B

3.23 Coupling mechanism retention force. When tested as specified in 4.6.20, the coupling mechanism shall not be dislodged from the connector and shall be capable of meeting the requirements of 3.5.1 immediately after the test.

3.24 RF leakage. When connectors are tested as specified in 4.6.21, the total leakage cable to cable shall not exceed that specified (see 3.1).

3.25 Risetime degradation. When connectors are tested as specified in 4.6.22, the risetime degradation shall be less than 400 picoseconds (ps).

3.26 Connector durability. When connectors are tested as specified in 4.6.23, they shall show no evidence of severe mechanical damage and the coupling device shall remain functional. Connectors shall meet the applicable requirements of 3.5 and 3.7.

3.27 Marking. Connectors and associated fittings shall be permanently and legibly marked in accordance with the general marking requirements of MIL-STD-1285 with the military PIN and the manufacturer's federal supply code. The marking location is optional when practicable, a location should be picked that will least likely be covered in cable assembly or installation.

3.28 Workmanship. Connectors and associated fittings shall be processed in such a manner as to be uniform in quality and shall be free from sharp edges, burrs and other defects that will affect life, serviceability or appearance.

3.29 Assembly instructions. Complete assembly instructions shall be furnished by the vendor with each connector supplied under this specification (see 6.2).

4. VERIFICATION

4.1 Classification of inspections. The inspection requirements specified herein are classified as follows:

- a. Qualification inspection (see 4.3).
- b. Conformance inspection (see 4.5).
- c. Periodic inspection (see 4.5.2).

4.2 Inspection conditions. Unless otherwise specified, all inspections shall be performed in accordance with the test conditions specified in the 'GENERAL REQUIREMENTS of MIL-STD-202 or EIA 364. For each test of threaded coupling connectors, where the test is performed on mated pairs, the pair shall be torqued to the specified value (see 3.1).

4.3 Qualification inspection. Qualification inspection shall be performed at a laboratory acceptable to the Government (see 6.3) on sample units produced with equipment and procedures normally used in production.

4.3.1 Sample size. Twenty five class 1 connectors of the same PIN with its mating connector or fifteen class 2 connectors of the same PIN with its mating connector (see 1.2.1) shall be subjected to qualification inspection.

4.3.2 Group qualification. For group qualification of all series of connectors covered by this specification (see 3.1). Group qualification will be limited to those connectors for which evidence of manufacturing capability is demonstrated by providing engineering drawings to the qualifying agency. The Government reserves the right to authorize performance of any or all qualification inspection of additional types in the group that are considered necessary for qualification within each group.

MIL-PRF-49142B

4.3.3 Inspection routine. The sample shall be subjected to the inspections specified in table II. All sample units shall be subjected to the inspection of group I. The sample units shall then be divided equally into six groups of 5 units (class 1) or three units each (class 2) and subjected to the inspection for their particular group and in the sequence given for that group.

4.3.4 Failures. One or more failures shall be cause for refusal to grant qualification approval.

4.4 Retention of qualification. To retain qualification, the contractor shall verify in coordination with the qualifying activity the capability of manufacturing products which meet the performance requirements of this specification. Refer to the qualifying activity for the guidelines necessary to retain qualification to this particular specification. The contractor shall immediately notify the qualifying activity at any time that the inspection data indicates failure of the qualified product to meet the performance requirements of this specification.

MIL-PRF-49142B

TABLE II. Qualification inspection.

Examination or test	Requirement paragraph	Test method paragraph
<u>Group I</u>		
Visual and mechanical examination	3.1	4.6.1
Material	3.3	4.6.1
Finish	3.3.1	4.6.1
Dissimilar metals	3.3.2	4.6.1
Configuration and features (dimensions)	3.4	4.6.1.1
Marking	3.27	4.6.1
Workmanship	3.28	4.6.1
Mating (visual indications)	3.4.2	4.6.1
Force to engage/disengage	3.5	4.6.2
Bayonet and threaded type	3.5.1	4.6.2.1
"Push-on" connector types	3.5.2	4.6.2.2
Coupling proof torque <u>1/</u>	3.6	4.6.3
Force to engage/disengage	3.5	4.6.2.1
Connector interfaces	3.4.4	4.6.1
Mating characteristics	3.7	4.6.4
Permeability of nonmagnetic materials	3.8	4.6.5
Hermetic seal <u>2/</u>	3.9	4.6.6
Leakage <u>2/</u>	3.10	4.6.7
Insulation resistance	3.11	4.6.8
<u>Group II</u>		
Conductor retention <u>3/</u>	3.12	4.6.9
Salt spray (corrosion)	3.13	4.6.10
<u>Group III</u>		
Dielectric withstanding voltage	3.14	4.6.11
Vibration, high frequency <u>4/</u>	3.15	3.6.12
Shock (specified pulse) <u>4/</u>	3.16	4.6.13
Thermal shock	3.17	4.6.14
Moisture resistance	3.18	4.6.15
Conductor resistance	3.19	4.6.16
<u>Group IV</u>		
Corona level <u>4/</u>	3.20	4.6.17
RF high potential withstanding voltage <u>4/</u>	3.21	4.6.18
Cable retention force	3.22	4.6.19
Coupling mechanism retention force	3.23	4.6.20
<u>Group V</u>		
RF leakage <u>4/</u>	3.24	4.6.21
Risetime degradation	3.25	4.6.22
Connector durability	3.26	4.6.23
<u>Group VI</u>		
Conductor resistance	3.19	4.6.16

1/ Threaded connectors only.

2/ Pressurized connectors only.

3/ Captivated center conductor only.

4/ These tests to be performed only during initial qualification as long as the qualifying design and manufacturing process has not been changed.

MIL-PRF-49142B

4.5 Conformance inspection.

4.5.1 Inspection of product for delivery. Inspection of product for delivery shall consist of groups A and B inspection.

4.5.1.1 Inspection lot. An inspection lot shall consist of all connectors of the same PIN produced under essentially the same conditions, and offered for inspection at one time.

4.5.1.2 Group A inspection. Group A inspection shall consist of the inspections specified in table III in the order shown.

4.5.1.2.1 Sampling plan (group A). Table III tests shall be performed on a production lot basis. Samples shall be selected in accordance with table IV. If one or more defects are found, the lot shall be screened for that particular defect and defects removed. A new sample of parts shall be selected in accordance with table IV and all group A tests again performed. If one or more defects are found in the second sample, the lot shall be rejected and shall not be supplied to this specification.

TABLE III. Group A inspection.

Inspection	Requirement paragraph	Test method paragraph	Sampling procedure
Visual and mechanical examination	3.1	4.6.1	See table IV
Material	3.3	4.6.1	
Finish <u>1/</u>	3.3.1	4.6.1	
Dissimilar metals	3.3.2	4.6.1	
Configuration and features (dimensions)	3.4	4.6.1.1	
Marking	3.27	4.6.1	
Workmanship	3.28	4.6.1	
Mating (visual indication)	3.4.2	4.6.1	
Dielectric withstanding voltage	3.14	4.6.11	
Hermetic seal (pressurized connectors only) <u>2/</u>	3.9	4.6.6	
Leakage (pressurized connectors only) <u>2/</u>	3.10	4.6.7	

1/ Verification of finish may be accomplished using the manufacturers process controls providing these controls are clearly equal to or more stringent than the requirements of this specification.

2/ Pressurized connectors only.

4.5.1.2.2 Visual inspection (group A inspection). Each connector shall be visually examined for completeness, workmanship, and identification requirements. Attention shall be given to those assemblies that require a gasket to determine the condition of the gasket. Gaskets missing, twisted, buckled, kinked, or damaged in any way shall be cause for rejection.

MIL-PRF-49142B

TABLE IV. Inspection level.

Lot size	Sample size
1 to 20	All
21 to 280	20
281 to 1,200	47
1,201 to 3,200	53
3,201 to 10,000	68
10,001 to 35,000	77
35,001 to 150,000	96
150,001 to 500,000	119
500,001 and over	143

4.5.1.3 Group B inspection. Group B inspection shall consist of the inspections specified in table V in the order shown, and shall be made on sample units which have been subjected to and passed the group A inspection. Connectors having identical piece parts may be combined for lot purposes and shall be in proportion to the quantity of each PIN numbered connector produced.

4.5.1.3.1 Group B sampling plan. A sample of parts shall be randomly selected in accordance with table VI. If one or more defects are found, the lot shall be screened for that particular defect and defects removed. After screening and removal of defects, a new sample of parts shall be randomly selected and subjected to all tests in accordance with table V. If one or more defects are found in the second sample, the lot shall be rejected and shall not be supplied to this specification.

TABLE V. Group B inspection.

Inspection	Requirement paragraph	Test method paragraph
Force to engage/disengage	3.5	4.6.2
Bayonet and threaded types	3.5.1	4.6.2.1
"Push-on" connector types	3.5.2	4.6.2.2
Coupling proof torque	3.6	4.6.3
Force to engage/disengage	3.5.1	4.6.2.1
Connector interfaces <u>1/</u>	3.4.4	4.6.1
Mating characteristics	3.7	4.6.4
Permeability of nonmagnetic materials	3.8	4.6.5
Insulation resistance	3.11	4.6.8

1/ Threaded connectors only.

MIL-PRF-49142B

TABLE VI. Inspection level.

Lot size	Sample size
1 to 90	5
91 to 150	11
51 to 280	13
281 to 500	16
501 to 1,200	19
1,201 to 3,200	23
3,201 to 10,000	29
10,001 to 35,000	35
35,001 and over	40

4.5.1.3.2 Disposition of sample units. Sample units which have passed all the group B inspection may be delivered on the contract or order, if the lot is accepted. Any connector deformed or otherwise damaged during testing shall not be delivered on the contract or order.

4.5.2 Periodic inspection. Periodic inspection shall consist of group C. Except where the results of these inspections shown noncompliance with the applicable requirements (see 4.5.2.1.4), delivery of products which have passed groups A and B shall not be delayed pending the results of these periodic inspections.

4.5.2.1 Group C inspection. Group C inspection shall consist of the inspections specified in table VII in the order shown. Group C inspection shall be made on sample units selected from inspection lots which have passed the groups A and B inspection.

4.5.2.1.1 Sampling plan. Fifteen sample units of the same PIN shall be selected from the first lot produced after the date of notification of qualification. Thereafter, 15 sample units of the same PIN shall be selected from current production after 200,000 connectors have been produced, or not less than once every three years, whichever occurs first. The sample units shall be divided equally and subjected to the inspections of the five subgroups.

4.5.2.1.2 Failures. If one or more sample units fail to pass group C inspection, the lot shall be considered to have failed.

4.5.2.1.3 Disposition of sample units. Sample units which have been subjected to group C inspection shall not be delivered on the contract or order.

4.5.2.1.4 Noncompliance. If a sample fails to pass group C inspection, the manufacturer shall notify the qualifying activity and the cognizant inspection activity of such failure and take corrective action on the materials or processes, or both, as warranted, and on all units of product which can be corrected and which are manufactured under essentially the same materials and processes, and which are considered subjected to the same failure. Acceptance and shipment of the product shall be discontinued until corrective action acceptable to the qualifying activity has been taken. After the corrective action has been taken, group C inspection shall be repeated on additional sample units (all tests and examinations, or the test which the original sample failed, at the option of the qualifying activity). Groups A and B inspections may be reinstated however, final acceptance and shipment shall be withheld until the group C inspection has shown that the corrective action was successful. In the event of failure after reinspection, information concerning the failure shall be furnished to the cognizant inspection activity and the qualifying activity.

MIL-PRF-49142B

TABLE VII. Group C Inspection.

Inspection	Requirement paragraph	Test method paragraph
Subgroup 1		
Conductor retention <u>1/</u>	3.12	4.6.9
Salt spray (corrosion)	3.13	4.6.10
Subgroup 2		
Dielectric withstanding voltage	3.14	4.6.11
Vibration, high frequency <u>2/</u>	3.15	4.6.12
Shock (specified pulse) <u>2/</u>	3.16	4.6.13
Thermal shock	3.17	4.6.14
Moisture resistance	3.18	4.6.15
Conductor resistance	3.19	4.6.16
Subgroup 3		
Visual and mechanical	3.1	4.6.1
Material	3.3	4.6.1
Finish	3.3.1	4.6.1
Dissimilar metals	3.3.2	4.6.1
Corona level <u>2/</u>	3.20	4.6.17
RF high potential withstanding voltage <u>2/</u>	3.21	4.6.18
Cable retention force	3.22	4.6.19
Coupling mechanism retention force	3.23	4.6.20
Subgroup 4		
RF leakage <u>2/</u>	3.24	4.6.21
Risetime degradation	3.25	4.6.22
Connector durability	3.26	4.6.23
Subgroup 5		
Conductor resistance	3.19	4.6.16

1/ Captivated center conductor only.

2/ These tests to be performed only during initial qualification as long as the qualifying design and manufacturing process has not been changed.

MIL-PRF-49142B

4.6 Methods of inspection. The following identified tests and test methods assure connector integrity within typical operating conditions and applications. Alternate commercial industry standard test methods are allowed however; when an alternate method is used the qualifying activity must be notified prior to the performance of the test. The test methods described herein are proven methods and shall be the referee method in case of dispute.

4.6.1 Visual and mechanical examination. Connectors and associated fittings shall be examined to verify that the design, construction, physical dimensions, marking and workmanship are in accordance with the applicable requirements (see 3.1, 3.3, 3.4, 3.27, and 3.28).

4.6.1.1 Dimensional examination. Mating dimensions shall be examined by mating the connector with its applicable mating gages or other suitable means acceptable to the Government.

4.6.2 Force to engage/disengage (see 3.5).

4.6.2.1 Bayonet and threaded types (see 3.5.1). The connector shall be engaged with its mating standard part (see 3.1). During the entire coupling/uncoupling cycle (until the connector is fully engaged/disengaged) the forces and/or torques necessary shall not exceed those specified (see 3.1). A thread coupled connector is fully engaged with its mating standard part when their reference planes (see 3.1) coincide. A bayonet coupled connector is fully engaged with its mating standard part when the bayonet studs have passed the detent and their reference planes coincide. No additional tightening torque shall be applied. The mating standard part is a steel jig containing the critical interface dimensions finished to the tolerances specified (see 3.1). As an option for this test, a qualified mating connector may be used in place of the standard steel jig with the approval of the qualifying agency (see 3.1). Its spring members when applicable shall be heat treated beryllium copper. The surface finish or mating surfaces shall be 16 microinches maximum, in accordance with ANSI B46.1.

4.6.2.2 "Push-on" connector types (see 3.5.2). The connector under test shall be engaged with its standard mating part (gage). As an option for this test, a qualified mating connector may be used in place of the standard steel jig with the approval of the qualifying agency. During this engaging cycle the force necessary to fully engage the connectors shall not exceed that specified (see 3.1). Upon completion of engagement, an opposite force necessary for disengagement shall be applied. This force shall be within the limits specified, and shall include any unlatching forces required.

4.6.3 Coupling proof torque (threaded types only) (see 3.6). The connector under test shall be engaged with its mating standard part (gage). As an option for this test, a qualified mating connector may be used in place of the standard steel jig with the approval of the qualifying agency, and their reference planes (see 3.1) shall coincide. The coupling nut shall be tightened to the torque value specified (see 3.1). After 1 minute the connector under test and its mating standard part shall be disengaged.

4.6.4 Mating characteristics (see 3.7). After insertion of the specified oversize pin the specified number of times (see 3.1), the contact to be tested shall be held rigid by means of a suitable jig or fixture. As an option for this test, a qualified mating connector may be used in place of the standard steel jig with the approval of the qualifying agency. A gage containing the test pin or test ring and a suitable force indicating dial shall be aligned to within 0.004 total indicator reading (T.I.R) of any plane passing through the axis of the contact under test. Engagement or withdrawal of the test pin or test ring shall be made smoothly and at such a rate that the dial does not bounce or otherwise give a false reading. The test pin or test ring may be chamfered to facilitate entry, but the specified engagement length shall not include the chamfer length and the finish shall be as specified and in accordance with ANSI B46.1.

4.6.5 Permeability of nonmagnetic materials (see 3.8). The permeability of the connector shall be measured with an indicator conforming to ASTM A342.

MIL-PRF-49142B

4.6.6 Hermetic seal (pressurized connectors only) (see 3.9). Connectors shall be tested in accordance with method 112 of MIL-STD-202. The following details shall apply:

- a. Test condition letter: C.
- b. Procedure number: III.
- c. Leakage rate sensitivity: 10^8 cubic centimeters (cm^3) per second.

4.6.7 Leakage (pressurized connectors only) (see 3.10). Connectors shall be subjected to air pressure specified (see 3.1), applied to one end, and the whole assembly immersed in water at a temperature of 15° to 25°C . The connector shall remain immersed for at least 2 minutes.

4.6.8 Insulation resistance (see 3.11). When applicable, (see 3.1), the connector shall be tested in accordance with test procedure 021 of EIA 364. The following details shall apply:

Points of measurement:

1. Between center conductor anti intermediate conductor.
2. Between intermediate conductor and outer conductor and/or body.

4.6.9 Conductor retention (captivated center conductor only) (see 3.12). An axial force (see 3.1), shall be applied first in one direction and then the other, to the center contact of an assembled and uncabled connector utilizing a method and force measuring device suitable to the Government. The intermediate conductor shall be inspected after the force has been applied in one direction and again after the force has been applied in the opposite direction to determine if the conductor has been displaced from the specified interface dimensions.

4.6.10 Salt spray (corrosion) (see 3.13). Unless otherwise specified (see 3.1), unmated and uncabled connectors shall be tested in accordance with method 101 of MIL-STD-202. The following details shall apply:

- a. Test condition letter-B.
- b. Measurements after exposure: Connectors shall be washed, shaken, and lightly brushed, then permitted to dry for 24 hours at 40°C . Connectors shall then be examined for evidence of corrosion, pitting, and shall be tested as specified in 4.6.2.1 or 4.6.2.2, as applicable.

4.6.11 Dielectric withstanding voltage (see 3.14). Connectors shall be tested in accordance with method 301 of MIL-STD-202. The following details shall apply:

- a. Special preparations or conditions:
 1. The maximum relative humidity shall be 50 percent. When facilities are not available at this test condition, connectors shall be tested at room ambient relative humidity. In case of dispute, if the test has been made at room ambient relative humidity, retest shall be made at 50 percent maximum relative humidity.
 2. The center contact of the plug connectors and receptacle connectors shall be positioned in such a manner as to simulate actual assembly conditions.
 3. Precaution shall be taken to prevent air-gap voltage breakdowns.
 4. The voltage shall be metered on the high side of the transformer.
- b. Magnitude of test voltage (see 3.1). The voltage shall be instantaneously applied.
- c. Nature of potential - Alternating current
- d. Points of application of test voltage:
 1. Between the center conductor and intermediate conductor.
 2. Between intermediate conductor and outer conductor.

MIL-PRF-49142B

4.6.12 Vibration, high frequency (see 3.15). A complete assembly shall be tested in accordance with test procedure 028 of EIA 364, condition III. The measurements shall be by visual examination and shall be made as specified in 4.6.1.

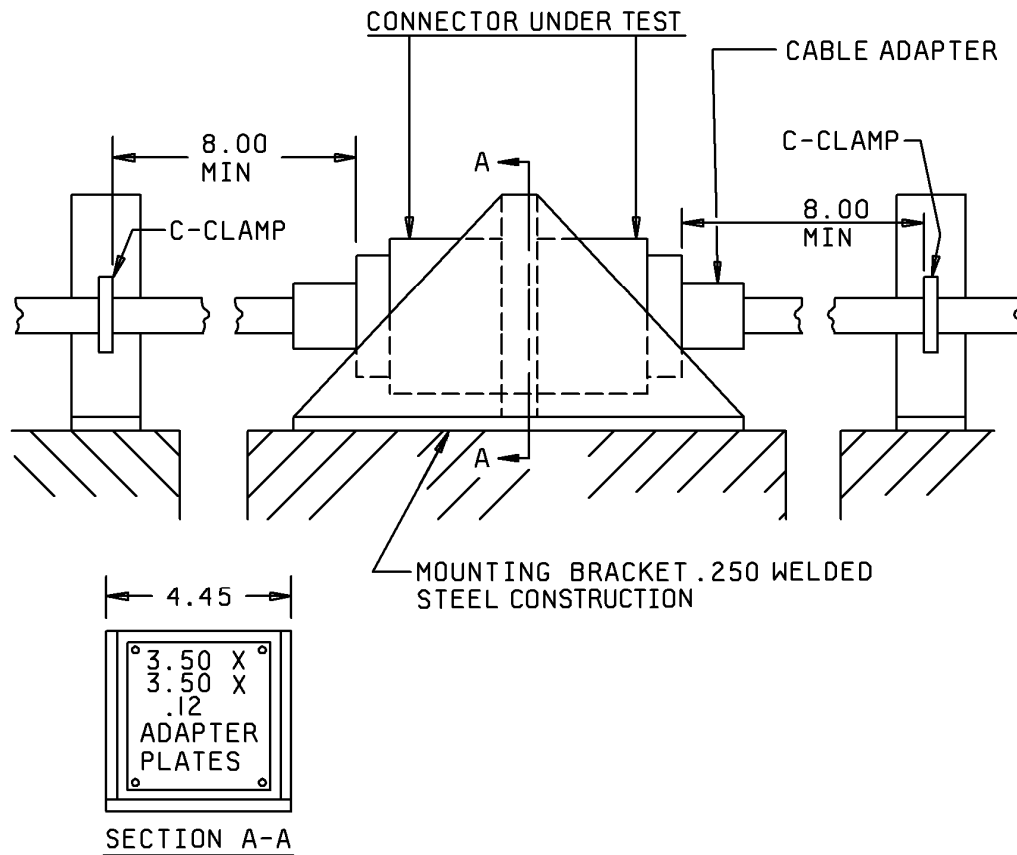

FIGURE 2. Typical vibration testing setup.

4.6.13 Shock (specified pulse) (see 3.16). The connector shall be mated with its mating connector (see 3.1) and subjected to test procedure 027 of EIA 364. The following details shall apply:

- a. Mounting - Receptacles and panel or bulkhead mounted connectors and shall be mounted by normal means. Other connectors shall be rigidly clamped to the shock test table.
- b. Test condition letter - E

4.6.14 Thermal shock (see 3.17). Unmated connectors shall be subjected to method 107 of MIL-STD-202. The following details and exception shall apply:

- a. Test condition letter - B, except test high temperature shall be +85°C.
- b. Final measurements - Dielectric withstanding voltage shall be measured as specified in 4.6.11 after the test an examination for mechanical damage shall be made.

MIL-PRF-49142B

4.6.15 Moisture resistance (see 3.18). Unless otherwise specified (see 3.1), connectors shall be mated and cabled with its mating connector and subjected to test procedure 031 of EIA 364. The following details and exception shall apply:

- a. Initial measurements - None.
- b. Loading voltage - No load.
- c. Procedure - Type IV.
- d. Final measurements:
 - 1. At high humidity - None.
 - 2. After the drying period - Insulation resistance, shall be measured as specified in 4.6.8.

4.6.16 Conductor resistance (see 3.19). All conductor resistance tests shall be conducted with the apparatus shown on figure 3. Circuit adjustments and the measurement procedures for all conductor resistance tests shall be in accordance with 4.6.16.1. The conductor resistance to be measured as follows:

- a. Conductor resistance of the mated center conductor contact from terminal end to terminal end.
- b. Conductor resistance of the mated intermediate conductor contact from terminal end to terminal end.
- c. Conductor resistance of mated outer conductor contact between points on the cable braid, or outer conductor, close to the terminal ends of the outer conductor contacts. The coupling nut must be removed for this test or from appropriate wires for uncabled connectors.

4.6.16.1 General procedure. The apparatus shall be assembled as shown on figure 3. The contacts, C1- C2, shown on the figure represent the mating contacts upon which millivolt (mV) drop tests are to be conducted.

MIL-PRF-49142B

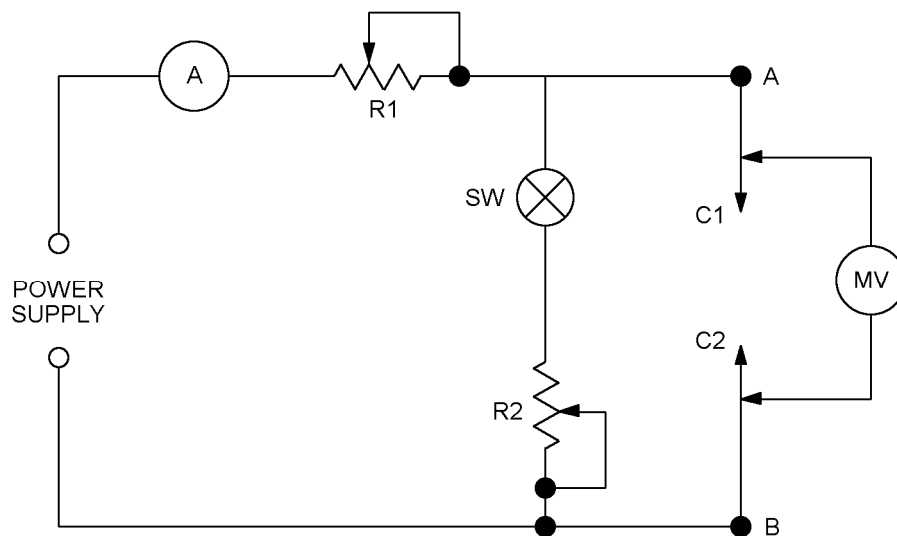

- a. Remove contacts $C_1 - C_2$ from the measuring circuit.
- b. Close switch SW.
- c. Adjust R_2 for a voltmeter reading of 50 millivolts.
- d. Connect contacts $C_1 - C_2$ to the measuring circuit and mate.
- e. Check to see that the voltmeter reading drops significantly prior to opening switch in "f".
- f. Open switch SW.
- g. Adjust R, for a circuit current (A) of one ampere.
- h. Measure the mV drop across contacts C, - C, and call this V.
- i. Compute contact resistance, contact resistance (milliohms) (mQ) = $mV \div 1A$.

FIGURE 3. Typical diagram for contact resistance.

MIL-PRF-49142B

4.6.17 Corona level (see 3.20). The test sample shall be connected to a mating connector and arranged in a suitable test circuit such as indicated on figure 4. For this test tie both the intermediate and outer conductors (shields) to ground. Components of the test circuit shall be corona free to the extent that a discharge of 5 pico coulombs (pc) or less can be measured when the 60 hertz (Hz) test potential is increased to the value specified at the reduced pressure specified (see 3.1). The type and length of cable used shall be as specified (see 3.1). No grease or similar compounds shall be used in or on the test item. After the sample is purged of air, the 60 Hz voltage shall be slowly increased until the detector, operated at a sensitivity of 5 pc, indicates a sustained corona discharge. The voltage shall then be decreased until corona is at 5 pc level or less. The latter value is the corona level of the connector under test. The manufacturer may at his option, use a corona detector (which has been approved by the Government) for performing the test in lieu of the test set up on figure 4.

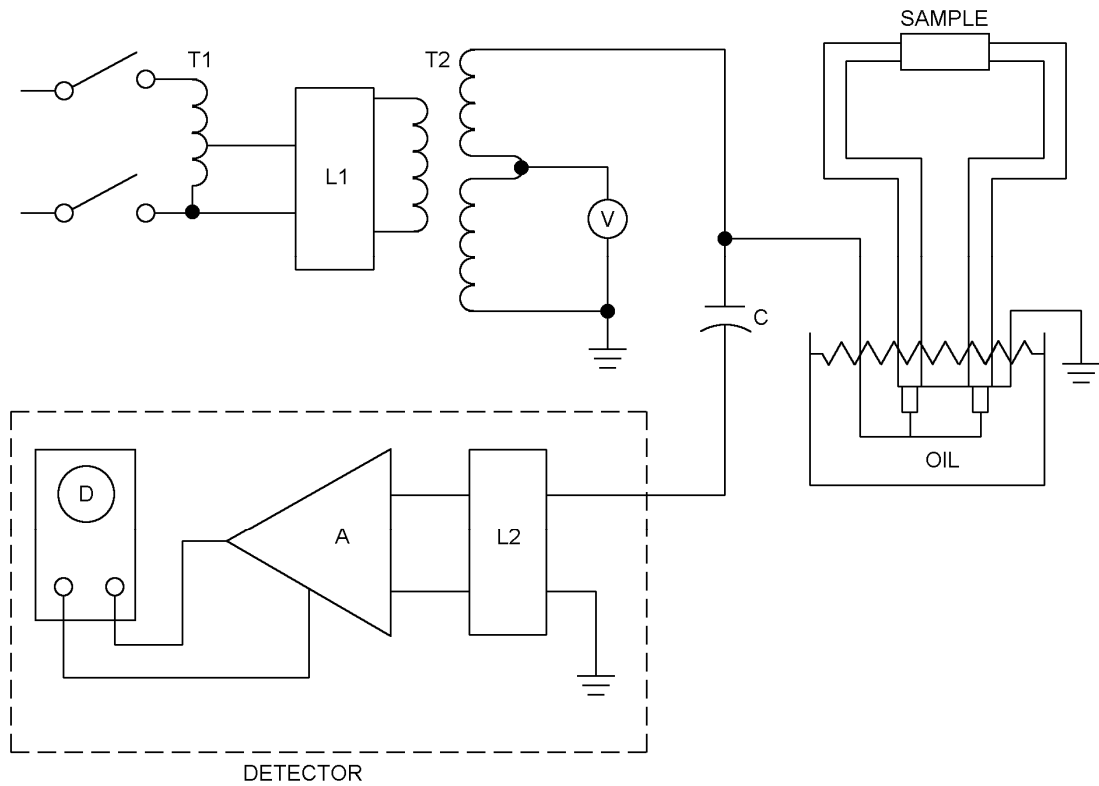

C - Corona free coupling capacitor (Note 1).
 L1 - Input line filter (see note 2).
 A - Detector amplifier.
 T2 - High voltage transformer (corona free,
 less than 5 picocoulombs).

D - Discharge display.
 L2 - 10-50 kHz detector input filter.
 T1 - 0-1 30V Variable transformer.
 V - Voltmeter.

NOTES:

1. Equal to or greater than total circuit capacitance.
2. 100 dB 14 kHz to 10 GHz.

FIGURE 4. Typical equipment and schematic for measuring corona level.

MIL-PRF-49142B

4.6.18 RF high potential withstanding voltage (see 3.21). Connectors shall be mated with their mating connectors and cable appropriately attached. This assembly shall then be inserted into the high impedance circuit as shown on figure 5, or equivalent, and instantaneously subjected to the RF voltage and frequency specified, (see 3.1). The RF voltage shall be applied in turn between the center conductor and intermediate conductor and at a different level between the intermediate conductor and outer conductor. The duration of the test shall be 1 minute. The RF voltage source shall be frequency stabilized and have an approximate pure sine wave output with minimum harmonic content. Means shall be provided to indicate disruptive discharge and leakage current

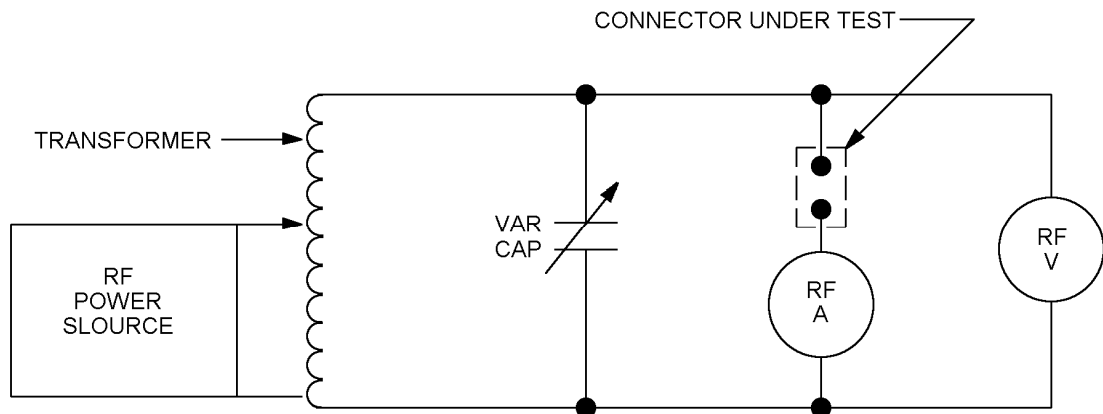

FIGURE 5. Typical circuit diagram for RF high potential withstanding voltage.

4.6.19 Cable retention force (see 3.22). When applicable (see 3.1), the connector shall be assembled to its standard mating test cable. The connector shall be firmly fixed and a movable sleeve attached to the cable. The sleeve is then moved longitudinally away from the fixed connector gradually and in such a manner that the cable remains unbent and untwisted. A scale for measuring the retention force (see 3.1) shall be attached to the sleeve. The force shall be held for 30 seconds minimum. The assembly shall then be examined for mechanical failure, loosening, or rupture and tested with a suitable low voltage continuity circuit. With the connector still in the fixed position, the cable shall be held at a point 10 times the diameter of the cable from the connector and a torque shall be applied in both directions as specified (see 3.1). The cable shall then be bent at a radius of 10 times the diameter of the cable starting at the connector at an angle of $90^\circ \pm 5^\circ$ from the axis of the connector, then reversed $180^\circ \pm 10^\circ$. Repeat this procedure four times, then retest and reexamine as outlined above.

MIL-PRF-49142B

4.6.20 Coupling mechanism retention forces (see 3.23). The connector body and coupling mechanism shall be respectively secured to the lower and upper jaws of a tensile tester in an appropriate manner. A tensile load shall be applied at a rate of approximately 100 pounds per minute up to the force as specified and held at that value for 1 minute (see 3.1). During the 1 minute of steadily applied force, the coupling mechanism shall be rotated with respect to the connector body, two full revolutions in each direction.

4.6.21 RF leakage (see 3.24). The mating connector pair to be tested shall be assembled as shown and tested on figure 6. The close fitting brass tubing shall be machined to thread into connector in lieu of compression nut. This test setup between 500 MHz and 11 GHz, shall have a dynamic range from 20 dBm to better than 100 dBm or a difference of 90 dB. Using a + 20 dBm RF source with 10 dB isolation, an additional 30dB range can be obtained by use of attenuator pads or a step attenuator producing a total range of 120 dB. The shorting plunger is adjusted to produce a maximum reading in the detector with the triaxial assembly inserted. The insertion loss caused by the insertion of the triaxial assembly adjusted as shown is a measure of the total leakage of the mated connector pair both at its interface as well as at the damping points to both cables.

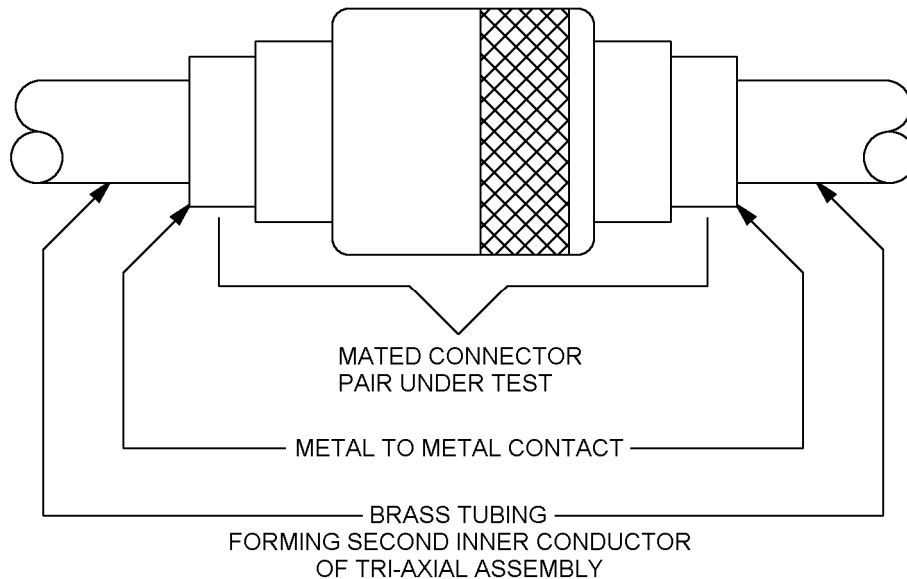
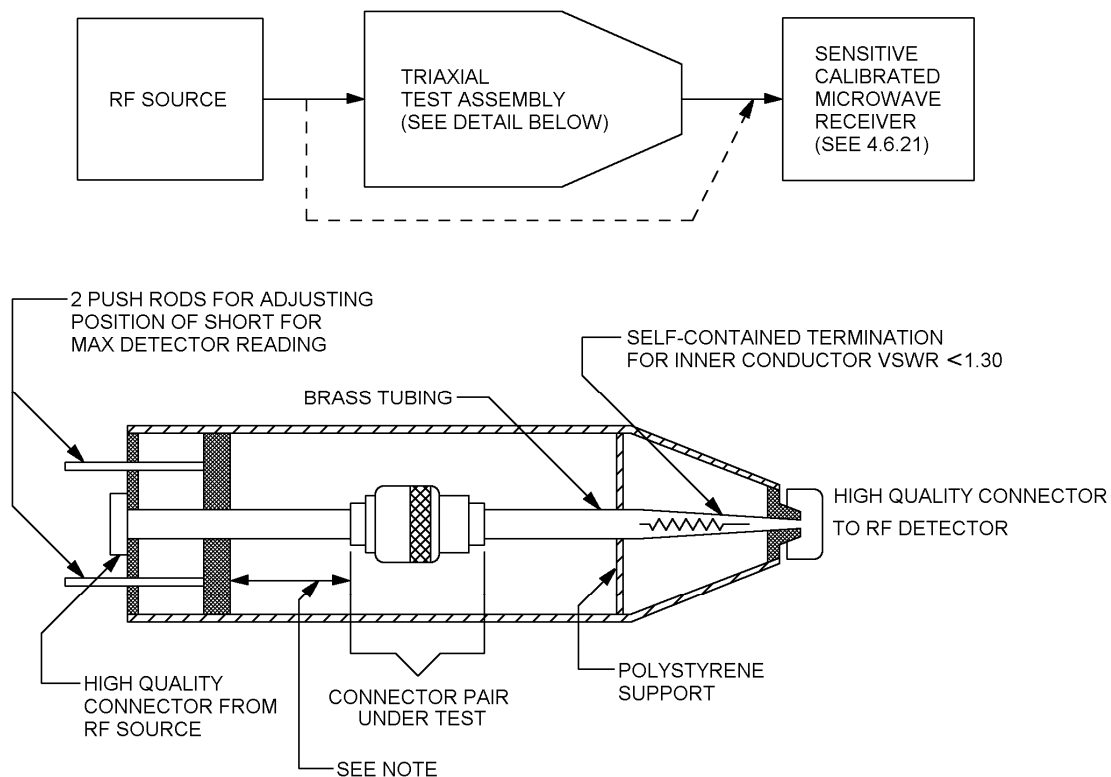

FIGURE 6. Connector assembly for RF leakage test.

MIL-PRF-49142B



NOTE: Travel of the short must exceed 1/2 wavelength.

FIGURE 6. Connector assembly for RF leakage test - Continued.

4.6.22 Risetime degradation (see 3.25). When applicable (see 3.1), the connector shall be assembled to a minimum of 10 feet of its standard mating test cable and tested to determine the amount of wave form distortion.

4.6.22.1 Equipment.

- a. Pulse generator having a risetime of 200 ps.
- b. A receiver capable of measuring to the required limits specified.
- c. Termination corresponding to the characteristic of cable tested.

MIL-PRF-49142B

4.6.22.2 Method. The test signal is to be a square wave pulse having a pulse width of 2 nanoseconds (ns) and pulse repetition frequency of 1 MHz. The risetime shall be measured from the 20 percent to 80 percent levels of the pulse edge. The generator output pulse shall be measured and recorded as T1. The specimen shall be inserted between the pulse source and the sampling lead; the output risetime shall be recorded as T2. The negative degradation, T3 shall be found from the following formula:

$$T3 = \sqrt{T2^2 - T1^2} \text{ reported in 10 foot lengths } T3 = \text{psi per 10 feet.}$$

4.6.23 Connector durability (see 3.26). Each cabled connector under test shall be mated with a typical production connector per this specification. The connector shall be subjected to the number of cycles of mating and unmating specified (sec 3.1). The connector and its mating part shall be completely engaged and completely disengaged during the cycle. Lubrication of the threads or rotational parts shall not be employed for this test unless specified (see 3.1). It is permissible to shake or blow debris from the threads or interface surfaces at intervals of not less than 50 cycles. Solvents or tools shall not be used for cleaning.

5. PACKAGING

5.1 Packaging. For acquisition purposes, the packaging requirements shall be as specified in the contract or order (see 6.2). When packaging of materiel is to be performed by DoD or in-house contractor personnel, these personnel need to contact the responsible packaging activity to ascertain packaging requirements. Packaging requirements are maintained by the Inventory Control Point's packaging activities within the Military Service or Defense Agency, or within the Military Service's System Commands. Packaging data retrieval is available from the managing Military Department's or Defense Agency's automated packaging files, CD-ROM products, or by contacting the responsible packaging activity.

6. NOTES

(This section contains information of a general or explanatory nature that may be helpful, but is not mandatory.)

6.1 Intended use. Connectors and fittings covered by this specification as intended for use with biaxial cable and can be used for RF applications when more shielding is required. It can also be used for serial digital transfer.

6.2 Acquisition requirements. Acquisition documents should specify the following:

- a. Title, number and date of the specification.
- b. Title, number and date of the applicable detail specification.
- c. Packaging requirements (see 5.1).
- d. The complete PIN of the connector or fitting ordered (see 3.27).
- e. Specific finish when required (see 3.3.1).
- f. Assembly instructions (see 3.29).

MIL-PRF-49142B

6.3 Qualification. With respect to products requiring qualification, awards will be made only for products which are, at the time of award of contract, qualified for inclusion in the applicable Qualified Products List 49412 whether or not such products have actually been so listed by that date. The attention of the contractors is called to these requirements, and manufacturers are urged to arrange to have the products that they propose to offer to the Federal Government tested for qualification in order that they may be eligible to be awarded contracts or orders for the products covered by this specification. Information pertaining to qualification of products may be obtained from the Defense Supply Center Columbus (DSCC-VQ), P.O. Box 3990, Columbus Ohio 43218-3990.

6.4 Subject term (keyword) listing.

Copper beryllium
Lead

6.5 Environmentally preferable material. Environmentally preferable materials should be used to the maximum extent possible to meet the requirements of this specification. Table VIII lists the Environmental Protection Agency (EPA) top seventeen hazardous materials targeted for major usage reduction. Use of these materials should be minimized or eliminated unless needed to meet the requirements specified herein (see section 3).

TABLE VIII. EPA top seventeen hazardous materials.

Benzene	Dichloromethane	Tetrachloroethylene
Cadmium and Compounds	Lead and Compounds	Toluene
Carbon Tetrachloride	Mercury and Compounds	1,1,1-Trichloroethane
Chloroform	Methyl Ethyl Ketone	Trichloroethylene
Chromium	Methyl Isobutyl Ketone	Xylenes
Cyanide and Compounds	Nickel and Compounds	

6.6 Changes from previous issue. Marginal notations are not used in this revision to identify changes with respect to the previous issue due to the extent of the changes.

CONCLUDING MATERIALS

Custodians:

Army - CR
Navy - EC
Air Force - 11
NASA - NA
DLA - CC

Preparing activity:
DLA - CC

(Project 5935-1783-000)

Review activities:

Army - AR, AT, MI
Navy - AS, MC, OS, SH
Air Force - 19, 99

NOTE: The activities listed above were interested in this document as of the date of this document. Since organizations and responsibilities can change, you should verify the currency of the information above using the ASSIST Online database at <http://assist.daps.dla.mil>.