

INCH-POUND

MIL-HDBK-844(AS)
20 October 1992

MILITARY STANDARDIZATION HANDBOOK

**AIRCRAFT REFUELING
HANDBOOK**



ASMC NA

DISTRIBUTION STATEMENT A.

Approved for public release; distribution is unlimited.

FSC-9130

MIL-HDBK-844(AS)

(This page intentionally left blank).

AIRCRAFT REFUELING HANDBOOK

TABLE OF CONTENTS

CHAPTER 1 INTRODUCTION	1-1
1.1 PURPOSE.	1-1
1.2 SCOPE.	1-1
1.3 COPIES.	1-1
1.4 CHANGES.	1-1
 CHAPTER 2 ORGANIZATION AND TRAINING	 2-1
2.1 ORGANIZATION	2-1
2.1.1. General.	2-1
2.1.2 Responsibilities and Duties.	2-1
2.1.2.1 Fuel Management Officer (FMO)	2-1
2.1.3.2 Assistant Fuel Management Officer (AFMO).	2-1
2.1.3.3 Fuel Delivery.	2-1
2.1.3.4 Storage and Transfer.	2-1
2.1.3.5 Quality Surveillance (QS).	2-2
2.1.3.6 Inventory.	2-2
2.1.3.7 Training.	2-2
2.2 TRAINING.	2-2
 CHAPTER 3 CHARACTERISTICS OF AVIATION FUELS	 3-1
3.1 INTRODUCTION.	3-1
3.2 TURBINE ENGINE FUELS.	3-1
3.2.1 JP-5 (NATO Code F-44).	3-2
3.2.2 JP-4 (NATO Code F-40).	3-2
3.2.3 JP-8 (NATO Code F-34).	3-2
3.2.4 Turbine Fuel Additives.	3-2
3.2.4.1 Fuel System Icing Inhibitor (FSII)	3-2
3.2.4.1.1 Icing Protection.	3-3
3.2.4.1.2 Biostat.	3-3
3.2.4.1.3 FSII Materials.	3-3
3.2.4.2 Lubricity Additive.	3-3
3.2.4.3 Antioxidant Additives.	3-3
3.2.4.4 Static Dissipator Additive (SDA) (JP-4/JP-8).	3-4
3.3 AVIATION GASOLINE.	3-4
 CHAPTER 4 CONTAMINATION OF AIRCRAFT FUELS	 4-1
4.1 GENERAL.	4-1
4.2 TYPES AND SOURCES OF CONTAMINATION.	4-1
4.2.1 PARTICULATE MATTER.	4-1
4.2.2 WATER.	4-2
4.2.3 CHEMICAL CONTAMINATION.	4-3
4.2.4 MICROORGANISMS.	4-3
4.3. COMMON SOURCES OF CONTAMINATION.	4-4
4.4 PROCEDURES FOR PREVENTING CONTAMINATION.	4-4
4.5 DETERIORATION OF AIRCRAFT FUELS.	4-5
4.6 SAMPLING OF AVIATION FUELS.	4-5

MIL-HDBK-844(AS)

CHAPTER 5 FLEET QUALITY SURVEILLANCE TESTS	5-1
5.1	5-1
5.2 PARTICULATE CONTAMINATION.	5-1
5.2.1 CFD Test Technique.	5-1
5.2.2 CFD Operating Procedure	5-2
5.2.3 Alternate Methods.	5-2
5.3 WATER CONTAMINATION.	5-3
5.3.1 FWD Test Technique.	5-3
5.3.2 FWD Operating Procedure.	5-3
5.3.3 Alternate Method	5-3
5.4 FUEL SYSTEM ICING INHIBITOR (FSII) CONTENT.	5-4
5.4.1 B/2 Test Technique.	5-4
5.4.2 B/2 Operating Procedures.	5-4
5.5 CONDUCTIVITY.	5-4
 CHAPTER 6 SAFETY IN FUEL HANDLING OPERATIONS	 6-1
6.1 INTRODUCTION.	6-1
6.2 ABNORMAL FUEL OPERATIONS.	6-1
6.3 FIRE AND EXPLOSION.	6-1
6.3.1 FLAMMABLE FUEL-AIR MIXTURES.	6-1
6.3.1.1 LOW VAPOR PRESSURE PRODUCTS.	6-1
6.3.1.2 INTERMEDIATE VAPOR PRESSURE PRODUCTS	6-2
6.3.1.3 HIGH VAPOR PRESSURE PRODUCTS.	6-2
6.3.2 FLAME SPREAD RATES	6-2
6.4 SOURCES OF IGNITION.	6-4
6.4.1 STATIC ELECTRICITY.	6-4
6.4.1.1 INTERNAL STATIC.	6-5
6.4.1.1.1 Charge Generation	6-5
6.4.1.1.2 Charge Accumulation.	6-5
6.4.1.1.3 STATIC DISCHARGE OR IGNITION.	6-5
6.4.1.1.4 CONTROL MEASURES.	6-6
6.4.1.2 EXTERNAL STATIC	6-6
6.4.1.2.1 Charge Generation.	6-6
6.4.1.2.2 Charge Accumulation and Dissipation	6-6
6.4.1.2.3 Control Measures for External Static	6-7
6.4.2 OPERATING ENGINES.	6-7
6.4.3 ARCING OF ELECTRICAL CIRCUITS.	6-7
6.4.4 OPEN FLAMES.	6-7
6.4.5 ELECTROMAGNETIC ENERGY.	6-7
6.4.6 HOT SURFACES OR ENVIRON-MENT.	6-7
6.5 EXTINGUISHMENT.	6-7
6.5.1 Fire Chemistry.	6-8
6.5.2 Classification of Fires.	6-8
6.5.2.1 Class A Fires.	6-8
6.5.2.2 Class B Fires.	6-8
6.5.2.3 Class C Fires.	6-8
6.5.2.4 Class D Fires.	6-8
6.5.3 Fire Extinguisher Types, Agents, and Methods of Application.	6-8
6.5.3.1 Halon 1211	6-8
6.5.3.1.1 Definition.	6-8
6.5.3.1.2 Application.	6-9

6.5.3.2 Carbon Dioxide (CO ₂)	6-9
6.5.3.2.1 Definition.	6-9
6.5.3.2.2 Application.	6-9
6.5.3.3 Purple-K-Powder (PKP)	6-10
6.5.3.3.1 Definition.	6-10
6.5.3.3.2 Application.	6-10
6.6 HEALTH HAZARDS.	6-10
6.6.1 TOXIC VAPOR EFFECT.	6-10
6.6.2 LEAD POISONING.	6-13
6.6.3 INJURY TO SKIN AND EYES.	6-13
6.6.4 SWALLOWING AVIATION FUELS.	6-13
6.6.5 FUEL TANK AND FILTER/SEPAR-ATOR WATER BOTTOMS	6-13
6.6.6 SPECIFIC PROCEDURES FOR AVOIDING THE HEALTH HAZARDS OF AIRCRAFT FUELS.	6-13
APPENDIX A VISUAL CONTAMINATION TABLE	A-1
APPENDIX B PETROLEUM TESTING LABORATORIES	B-1
APPENDIX C AIRCRAFT INFORMATION SUMMARIES	C-1
A-6	C-2
AV-8B	C-7
E-2/C-2	C-12
F-14	C-16
F-18	C-20
S-3	C-25
P-3	C-29
H-1	C-33
H-2	C-37
H-3	C-41
H-46	C-45
H-53	C-49
SH-60	C-54
APPENDIX D GLOSSARY	D-1

MIL-HDBK-844(AS)

(This page intentionally left blank).

CHAPTER 1

INTRODUCTION

1.1 PURPOSE. This handbook provides basic information on the properties and characteristics of aviation fuels along with general information on the standards, equipment, and operating principals related to the handling of these fuels at Navy and Marine Corps activities. It is designed to supplement the NATOPS AIRCRAFT REFUELING MANUAL, NATOPS 00-80T-109, by providing background information and guidance on the requirements and procedures contained in the NATOPS Manual.

1.2 SCOPE. The contents of this handbook are limited to technical and operational information of a general nature. Specific operating procedures and equipment requirements are contained in the NATOPS AIRCRAFT REFUELING MANUAL, NATOPS 00-80T-109. Accounting and stock control procedures are not included in this handbook or the NATOPS Manual.

1.3 COPIES. Copies of this Military Handbook are from:

Standardization Documents Order Desk
Bldg 4D
700 Robbins Avenue
Philadelphia, PA 19111-5094

1.4 CHANGES. The information contained herein has been derived from a number of diverse sources including the fueling experience of the Navy, Marine Corps, and commercial companies; the recommended practices of the American Petroleum Institute and the American Society for Testing and Materials; and the published findings of research activities.

Operating activities are encouraged to submit corrections, recommended changes, or innovations for this handbook by letter to:

Commander
Naval Air Systems Command
AIR-5363C
Washington, D.C. 20361-5360

MIL-HDBK-844(AS)

(This page intentionally left blank).

CHAPTER 2

ORGANIZATION AND TRAINING**2.1 ORGANIZATION**

2.1.1. General. The allowances for a Fuel Division should include personnel in adequate quantities and with sufficient grade structure, training, and seniority to ensure responsible operation of facilities and equipment in response to any operational demand.

The organization should be flexible enough to efficiently handle increased workload on short notice. This can best be accomplished by cross training and cross manning. Leave schedules and school attendance can be adjusted to accommodate workload peaks. Scheduled leave can be deferred if unexpected peaks are encountered. Lengthening working shifts and non-standard duty section, including stand-by duty section assignments, should be last resort measures.

Chapter 8 of the NATOPS Aircraft Refueling Manual, NAVAIR 00-80T-109, outlines a recommended standard organizational structure for Navy and Marine Corps fuel operations division. Shipboard organizational structures are established by applicable regulations and/or standard operating procedures instructions.

2.1.2 Responsibilities and Duties. The NATOPS Aircraft Refueling Manual, NAVAIR 00-80T-109, delineates fuels responsibilities at shore activities. For Shipboard operations, consult Shipboard Operation Regulation Manual 3120.32.

The following paragraphs list the normal duties assigned to various personnel within a typical shore activity fuels organization.

2.1.2.1 Fuel Management Officer (FMO). Directs and supervises the completely integrated fuel operations. An FMO typically:

- a. Estimates quantities of fuel products to be consumed and fuel service requirements.
- b. Develops proposed fuel budget.
- c. Performs contract administration services.
- d. Prepares and revises the activity fuel

instruction in accordance with the NATOPS Aircraft Refueling Manual and other applicable documents.

e. Prepares an oil spill prevention and counter-measure plan.

f. Prepares environmental impact statement for the U.S. Coast Guard on any procedural change and modification to plant facilities.

g. Plans and initiates military construction, repair, and improvement fuel projects.

h. Performs liaison with fuel service customers, activity departments, other governmental agencies, community official and commercial concerns.

i. Represents fuel interests on boards and committees.

2.1.3.2 Assistant Fuel Management Officer (AFMO). The AFMO assists the FMO in the supervision of the integrated fuel operations and performs the following special duties:

a. Directs the quality assurance program for fuel products.

b. Manages the petroleum laboratory.

c. Directs entire fuel training program.

d. Supervises inspections.

e. Maintains inventory control.

2.1.3.3 Fuel Delivery. The employee placed in charge of the fuel delivery section or branch is normally delegated the following specific duties:

a. Delivery of aviation POL products alongside aircraft.

b. Operation of hydrants to fuel aircraft with engines idling (hot refueling).

c. Operation of aircraft defuelers.

d. Dispatching of personnel and/or equipment and maintenance of dispatch log.

e. Delivery of ground products on automatic fill basis or as requested.

f. Pickup of waste oil.

g. Operational maintenance of facilities and equipment.

2.1.3.4 Storage and Transfer. The branch or section head in charge of fuel storage and delivery usually is assigned the following duties:

MIL-HDBK-844(AS)

- a. Receipt of POL products by pipeline tanker, barge, tank car or tank truck
- b. Storage of products.
- c. Operation of the distribution systems and transferring of products.
- d. Operation of vehicle service stations.
- e. Grass cutting in hazardous areas.
- f. Receipt and storage of packaged POL products.
- g. Operational maintenance of facilities and equipment.

2.1.3.5 Quality Surveillance (QS). The QS branch normally performs the following.

- a. Sampling POL products at point of receipt, in storage, when transferred in aircraft refuelers and aircraft tanks.
- b. Surveillance of fuel handling operations.
- c. Surveillance of POL filtration, water removal and monitoring equipment including the maintenance of pressure differential graphs.
- d. Operation of the POL laboratory.
- e. Inspection and surveillance of facilities and equipments including contract-owned equipment.

2.1.3.6 Inventory. The Inventory branch usually performs the following functions:

- a. Estimates of POL requirements.
- b. Scheduling of product deliveries.
- c. Preparation of fuel requisitions for replenishments.
- d. Maintenance of daily inventory records.
- e. Processing of receipt and issue documents.
- h. Monitoring of contract refueling fuel deliveries

2.1.3.7 Training. The branch assigned the training function normally performs the following duties:

- a. Preparation of training guide.
- b. Conducting classroom and on-the-job training.
- c. Certifying qualifications and issuing certificates.
- d. Maintenance of training and qualification records.
- e. Reviewing and supplementing contractors' training program.

2.2 TRAINING. It is essential to the safety of fuel handling operations that the personnel involved be properly trained. Historical records disclose that the instinctive reactions of experienced fuel operators during emergency situations have minimized personnel injuries, fuel losses, and the destruction of government property including aircraft. Conversely, the records show that the reactions of relatively untrained personnel, under similar situations, cannot be relied upon. The importance of proper training can not be over-emphasized.

CHAPTER 3

CHARACTERISTICS OF AVIATION FUELS

3.1 INTRODUCTION. There are basically two different types of aircraft fuels in use at Navy and Marine Corps air activities - turbine engine fuels and aviation gasolines (AVGAS). A knowledge of some of the basic properties and characteristics of these fuels is necessary in understanding the importance of delivering the proper fuel to the aircraft. Such knowledge is also valuable in understanding the need for safety and caution in handling aviation fuels.

Turbine engine fuels and aviation gasolines are petroleum products manufactured from crude oil by refineries. Both are classified as flammable liquids and will burn when ignited. Under the right conditions, they will explode with forces similar to those of dynamite. Death can result if the vapors of either type fuel are inhaled in sufficient quantities and serious skin irritation can result from contact with the fuels in the liquid form. In the liquid form, aircraft fuels are lighter than water and in the vapor form they are heavier than air. Consequently, any water present in the fuels will usually settle to the bottom of the container. On the other hand, vapors of these fuels, when released in the air, tend to remain close to the ground, thus increasing the danger to personnel and property. For safety and health considerations, both aviation gasolines and turbine engine fuels must be handled with equal caution. Additional information of the properties and characteristics of aviation fuels and their effects on the safe handling of these materials is contained in Chapter 6 of this handbook.

All aviation fuels are extremely good solvents. For example, AVGAS will dissolve common lubricants (such as oils and greases used in pumps, valve, packing, and other equipment) and can cause serious deterioration of many rubber materials. It is therefore extremely important that only materials specially designed, tested, and approved for use with aviation fuels be allowed to come into contact with them. Never use substitute greases, lubricants, packing, etc. on or with fuel handling equipment without first obtaining agreement from the cognizant

technical authority for the piece of equipment in question.

Aviation gasolines are used for piston-type (reciprocating) engines which are similar to automotive engines in terms of their basic operating principle. Turbine engine fuels, on the other hand, are intended for use in an entirely different type of engine. In place of the pistons found in reciprocating engines, turbine engines have an air compressor, a combustor, and a turbine which they use to turn fuel into usable propulsion energy. Since these are completely different types of engines, they require different types of fuels for proper operation. The following paragraphs provide some specific information on each type of fuel.

3.2 TURBINE ENGINE FUELS. While aircraft piston engines are sensitive to the fuel used and will only operate safely and satisfactorily on one grade of aviation gasoline, most aircraft turbine engines can use a variety of grades of aviation turbine fuels. The difference between the grades of turbine fuels is their volatility. Table 3-1 lists the more common grades of military and commercial aviation turbine fuels and gives a rough comparison of their volatilities through their flash points (a measure of the temperature at which the fuel can be ignited when sitting in a pool) and freeze points (the temperature at which the fuel forms solid crystals). Detailed information on the properties and requirements of each grade of fuel is contained in the applicable specification.

Although kerosene type turbine fuels, JP-5 and JP-8, are much less volatile than JP-4 and AVGAS, under the right conditions, such as severe agitation, mists can form which are as flammable and explosive as AVGAS. All aviation fuels must be handled carefully.

MIL-HDBK-844(AS)

	Grade	Specification	Fuel Type	NATO CODE	Freeze Point	Flash Point	Density (*API Gravity)
Military	JP-5	MIL-T-5624	Kerosene (High Flash)	F-44	-51°F -46°C	140°F 60°C	36 0-48 0
	JP-4	MIL-T-5624	Wide-Cut	F-40	-72°F -58°C	below -4°F -20°C	45 0-57 0
	JP-8	MIL-T-83133	Kerosene	F-34	-53°F -47°C	100°F 38°C	37 0-51.0
Commercial	Jet A	ASTM D 1655	Kerosene	none	-40°F -40°C	100°F 38°C	37 0-51.0
	Jet A-1	ASTM D 1655	Kerosene	F-35	-53°F -47°C	100°F 38°C	37 0-51 0
	Jet B	ASTM D 1655	Wide-Cut	none	-72°F -58°C	below -4°F -20°C	45 0-57 0

Table 3-1. Grades of Turbine Engine Fuels.

3.2.1 JP-5 (NATO Code F-44) JP-5 is a kerosene fuel with an especially high flash point facilitating safety in shipboard handling. It is the only fuel that can be used for turbine engine aircraft aboard ships and is used widely at USN and USMC air stations. Because it has the highest density of all the aviation fuels, JP-5 has the greatest affinity for dirt, rust, and water contaminants.

3.2.2 JP-4 (NATO Code F-40). JP-4 is the primary fuel used at Air Force and Army bases in CONUS. JP-4 is a wide boiling range petroleum product including both gasoline and kerosene boiling range components. JP-4 exhibits better low temperature starting than JP-5. JP-4 fuel is intermediate between AVGAS and JP-5 with respect to its tendencies to acquire and hold dirt, rust, and water contaminants. It is an alternate fuel to JP-5 for USN and USMC jet aircraft. Both JP-4 and JP-5 fuels are procured under Military Specification MIL-T-5624.

3.2.3 JP-8 (NATO Code F-34). JP-8, procured under Military Specification MIL-T-83133, is a kerosene fuel similar to commercial jet fuel, ASTM Jet A-1, except JP-8 contains fuel system icing inhibitor as well as other fuel additives. It is also similar to JP-5 with respect to most fuel properties except flash point and freeze point. Since its flash point is not as high as JP-5's it cannot be used for shipboard operations. The Air Force is currently in the process of converting operations to JP-8 fuel in

order to take advantage of its similarity to commercial aviation turbine fuel and improved safety (lower volatility)

3.2.4 Turbine Fuel Additives. Although JP-5 and JP-8 are quite similar to commercial turbine fuels Jet A and Jet A-1 and JP-4 is basically the same fuel as Jet B, there are some very important differences. In addition to small but significant differences in volatility, all three military fuels contain the following additives which commercial jet fuels normally do not.

- a. Fuel System Icing Inhibitor (FSII)
- b. Lubricity Additive (corrosion inhibitor)
- c. Antioxidants (storage stability additives)
- d. Static Dissipator Additive (JP-4 and JP-8 fuels only)

JP-4 and JP-8 fuels also contain static dissipater additive (SDA) to improve their relaxation of static charges created by filtration and fuel movement. Since certain approved SDA additives adversely affect the performance of filter/separators, SDA is not added to JP-5. JP-5 handling systems must therefore have static charge relaxation chambers at appropriate points in order to eliminate static charges.

3.2.4.1 Fuel System Icing Inhibitor (FSII). FSII is added to the fuel for two reasons, it provides icing protection and also acts as a biostat.

3.2.4.1.1 Icing Protection. Even when the free water content of the fuel is maintained below the 5 ppm level, FSII is essential because, in addition to free water, aviation fuel contains a significant amount of dissolved water. In general, the amount of dissolved water a fuel will hold in parts per million (ppm) is approximately equal to the temperature of the fuel in degrees fahrenheit. For example, a fuel which is 70°F contains approximately 70 ppm dissolved water. If this fuel were cooled to 20°F it would then contain 50 ppm free water and 20 ppm dissolved water. When an aircraft is exposed to cold temperatures such as high altitudes or very cold weather conditions at sea level, the fuel contained in its tanks will drop in temperature allowing the water which is dissolved in the fuel to condense out into tiny droplets of free water. If the temperature of the fuel drops low enough (below 32°F) these droplets will form ice crystals which will collect on screens or filters in the fuel system quickly blocking them. In addition, the ice crystals can cause fuel system valves to stick or malfunction preventing the aircraft pilot from using or distributing his fuel load.

The result of using fuel without sufficient FSII can be the loss of an aircraft. Certain aircraft are more susceptible to these problems than others because of differences in their fuel system design as well as possible flight profiles. These aircraft are the S-3A, US-3A, and SH-60. For this reason they require a minimum FSII level of 0.03 percent by volume in their fuel. All other USN and USMC aircraft do not require FSII and may use JP-5 or other approved fuel even if it does not contain any FSII.

3.2.4.1.2 Biostat. FSII prevents the growth of fungi and other microorganisms which can develop at the interface between the fuel and any water which collects at the bottom of the tank (aircraft as well as fuel storage). Since these microbiological growths can form rapidly, clog filters, and degrade the fuel, every effort should be made to maintain FSII levels as high as possible in order to maximize its biostatic effect. The best way of maintaining these levels is to minimize contact of the fuel with water which tends to leach out the FSII from the fuel. F-44 tanks must therefore be stripped of water frequently - daily if any significant amount of water accumulates within a 24 hour period.

3.2.4.1.3 FSII Materials. There are currently two approved FSII materials. Both FSII materials are

considered mutagenic in the neat state but are considered safe once blended into the fuel. Most FSII is injected at the refinery or Defense Fuel Supply Depot. Shoreside personnel involved in the handling and injection of these additives are advised to follow all instructions, wear gloves and aprons, and minimize their exposure as much as possible. Since FSII materials tend to become concentrated in the water which collects at the bottoms of fuel tanks (aircraft as well as fuel storage) and filter/separators, personnel handling these waterbottoms are advised to follow similar precautions.

3.2.4.1.3.1 EGME, Ethylene Glycol Monomethyl Ether, defined by MIL-I-27686, is the approved FSII material for use in both JP-4 and JP-8 fuels. It is also the original FSII material used in JP-5. Older stocks of JP-5 may contain EGME since complete conversion of all FSII injection facilities to DiEGME was only recently accomplished.

3.2.4.1.3.2 DiEGME, Diethylene Glycol Monomethyl Ether, procured to MIL-I-85470, is currently the only approved FSII additive for use in JP-5 because of its high flash point. Since DiEGME is also considered significantly less mutagenic than EGME, JP-4 and JP-8 are currently being converted to the use of this FSII additive.

3.2.4.2 Lubricity Additive. A combination lubricity improver and corrosion inhibitor additive, procured under MIL-I-25017, is injected in all Military turbine fuels at the refinery in order to improve the lubricating characteristics of the fuel. A series of several contiguous (one immediately following another) flights with fuel which does not contain one of these additives may cause abnormal wear or malfunctions of aircraft and/or engine fuel system components. A few flights (one or two) will not contribute to such problems since the additives tend to leave a protective coating on the components.

3.2.4.3 Antioxidant Additives. These materials, which are injected into the fuel at the refinery, are particularly important for fuels which have been processed at the refinery with hydrogen. They insure that the fuel will be stable when placed in long term storage (a few months to several years). Commercial fuels do not need these additives since they are usually consumed within a few weeks to a couple of months. The first fuel property to drop below specification minimums in an unstable fuel is usually its thermal stability. Other properties such as

MIL-HDBK-844(AS)

total acid number, copper strip corrosion, and existent gums can also fall below acceptable minimums.

3.2.4.4 Static Dissipator Additive (SDA) (JP-4/JP-8). JP-4 and JP-8 fuels are injected with a special additive which increases the fuel's conductivity and helps relax static electric charges which are produced during fuel handling operations (filtration, pipeline movement, etc.). Static Dissipator Additive (SDA), as this additive is now called, was originally added to these fuels to prevent small static initiated explosions which were occurring during refueling of polyester foam filled USAF aircraft tanks. The USN and USMC have never experienced similar problems with foam filled tanks probably due to aircraft tank and refueling equipment design differences. In addition, limited laboratory testing of SDA in JP-5 indicates one of the currently approved SDA additive materials has an adverse effect on the performance of filter/separators in their removal of particulates and free water from the fuel. SDA has therefore not been added to JP-5.

When USAF or foreign government aircraft are refueled with JP-4 or JP-8, the fuel must exhibit conductivity above 100 pS/m as measured by a portable conductivity meter, NSN 6630-01-115-2398. An upper use limit of 700 pS/m has been established to protect the accuracy of certain sensitive aircraft fuel quantity gauging systems. Since SDA is depleted in the supply distribution system, USAF policy has been to add the additive as close as possible to the using activity or base. SDA is therefore most often being added at Defense Fuel Support Points (DFSP's).

It is not necessary for USN or USMC activities to frequently test the conductivity levels of their stocks of JP-4 or JP-8 fuel when they are only refueling USN or USMC aircraft. However, occasional testing of the conductivity of these fuels is recommended in order to ensure that SDA is being injected at the proper level, especially since excessively high levels can affect the accuracy of certain aircraft gauging systems. If on such checks the fuel is found to be out of the specification conductivity range, the injecting facility (DFSP or refinery) should be informed immediately so that the injection rate can be adjusted accordingly. In some instances where the refueling of USAF aircraft is involved, manual addition of SDA at base level may

be necessary in order to prevent aircraft damage. More information and assistance on this subject may be obtained from the USAF Technical Support Team located at Kelly Air Force Base, TX (DSN 945-4617).

In a couple of special situations where very large numbers of USAF aircraft are frequently refueled it may be necessary to have the JP-5 supplied to a naval air station injected with SDA. The above deterioration use limits are then applicable to JP-5.

3.3 AVIATION GASOLINE. Very little aviation gasoline (AVGAS) is currently being used by the U.S. Military services. For this reason the Military AVGAS Specification, MIL-G-5572, was cancelled in 1988 and Military needs are being satisfied via the commercial specification, ASTM D 910.

Aviation gasolines are graded according to their performance in a similar manner to the "octane" ratings used for automotive gasolines. "Performance Numbers," as they are called for aviation gasoline, are also based on the performance of the fuel in preventing engine knock, an extremely serious problem in aircraft engines due to the continuous high power demands placed upon them. The grades of AVGAS were formerly designated by two numbers i.e. 100/130. The first number indicated the performance rating with a lean fuel-air mixture while the second number indicated the knock rating with a rich fuel-air mixture. The new ASTM designations for these fuels now only refer to the lean knock rating. As listed in Table 3-2, the three grades of AVGAS are dyed various colors in order that they can be easily distinguished.

Grade 100 (high lead) and 100LL (low lead) have exactly the same performance characteristics and can be used interchangeably. The refining industry in the U.S. has been changing over to the lower lead version in order to meet Environmental Protection Agency requirements. Grade 100 and Grade 100LL may also be commingled in storage tanks at air stations. Please note that if these two fuels are mixed an unusual color may result. Grade 80 is a very low lead fuel with a lower performance rating. The very high performance fuel, 115/145, has almost completely disappeared and aircraft which used to demand this fuel have been modified to accept 100LL.

MIL-HDBK-844(AS)

Since Avgas is the lightest (lowest density) naval aviation fuel, it has the least tendency to acquire and hold in solution dirt, rust, and water contaminants making it the easiest aviation fuel to keep clean.

All AVGAS contains some tetra-ethyl lead for the improvement of its anti-knock performance. The presence of this fuel additive makes it very deleterious to turbine engines so it is extremely important that turbine fuels not be contaminated with even small amounts of AVGAS.

ASTM D 910	MIL-G-5572	Color	NATO Symbol
Grade 80	80/87	Red	
Grade 100	100/130	Green	
Grade 100LL	100/130 Low Lead	Blue	F-18
	115/145	Purple	

Table 3-2. Grades of Aviation Gasoline

MIL-HDBK-844(AS)

(This page intentionally left blank.)

CHAPTER 4

CONTAMINATION OF AIRCRAFT FUELS

4.1 GENERAL. Basic information and minimum requirements pertaining to the quality control of aviation fuels at Navy and Marine Corps air activities are contained in Chapters 3 and 9 of the NATOPS Aircraft Refueling Manual, NAVAIR 00-80T-109. This chapter provides a brief review of these requirements with amplifying information.

The major objective of fuel handling personnel is to deliver clean, water-free, and correct fuel to aircraft. The fuel systems of modern aircraft are complex and will not function properly if fuel is contaminated with dirt, water, or other foreign matter. Foreign matter in fuel can plug or restrict fuel pumping and metering equipment and accelerate the clogging of fuel filters. Fuel contaminated with water is harmful because ice may be formed at high altitudes also clogging aircraft components. The presence of water also permits the growth of microorganisms in aircraft fuel tanks which hinder the operation of components and cause corrosion in fuel systems.

Aircraft engine failure or poor performance may also be caused by incorrect fuel or by contamination of the proper fuel with other petroleum products. For example, a small amount of turbine engine fuel in aviation gasoline can significantly reduce its anti-knock quality. Similarly diesel fuel, lubricating oils and hydraulic fluids are harmful to the quality of both types of aviation fuels. Any contamination of aviation fuels is to be avoided

As a general rule, for aviation fuel to be acceptable to aircraft it must be clear, bright, and contain no free water. The terms "clear" and "bright" are independent of natural color of the fuel. The various grades of aviation gasoline have dyes added. Turbine fuels are not dyed and may be any color from water-white to straw yellow. "Clear" means the absence of any cloud, emulsion, readily visible particulate matter, or entrained water. "Bright" refers to the shiny appearance of clean, dry fuels. A cloud, haze, specks of particulate matter, or entrained water indicates that the fuel is unsuitable and points to a breakdown in fuel handling equipment or procedures.

4.2 TYPES AND SOURCES OF CONTAMINATION. Aircraft fuel can be contaminated with particulate matter, free water, foreign chemicals, microorganisms, or any combination of the four. In addition to the following paragraphs which discuss these various types of contamination, Appendix A is a guide to help in the detection and understanding of the consequences of the various types of contamination. In practice any significant (deleterious) amount of coarse material contaminant can usually be detected visually.

4.2.1 PARTICULATE MATTER. Particulate matter appears as dust, powder, grains, flakes, fibers, or stain. Particulate matter, or solid contamination, can be separated into two categories: (a) coarse matter and (b) fine matter.

(a) Coarse matter is matter that can be seen and that easily settles out of fuel or can be removed by adequate filtration. Ordinarily, Particles 10 microns in size and larger are regarded as coarse matter, (a micron is 1/1,000,000th of a meter or approximately 1/25,000th of an inch). Figure 4-1 illustrate just how small these particles can be. Coarse particles clog orifices and wedge in sliding valve clearances and shoulders, causing malfunctions of fuel controls and metering equipment. They are also effective in clogging nozzle screens and other fine screens throughout the aircraft fuel system.

(b) Fine matter may be defined as particles smaller than 10 microns. To a limited degree, fine matter can be removed by settling, filtration, and the use of centrifugal purifiers. Particles in this range accumulate throughout fuel controls, appearing as a dark shellac-like surface on sliding valves, and may also be settled out in rotating chambers as sludge-like matter, causing sluggish operation of fuel metering equipment. Fine particles are not visible to the naked eye as distinct or separate particles; they will, however, scatter light and may appear as point flashes of light or a slight haze in fuel. Occasionally a fuel contaminated with gross amounts of fine particulate matter may be encountered which does not respond to normal filtration and cleanup procedures. For shipboard applications notify TYCOM or higher

MIL-HDBK-844(AS)

authority for guidance. It may be necessary to install special 2 micron filters in order to bring such a fuel within deterioration use limits.

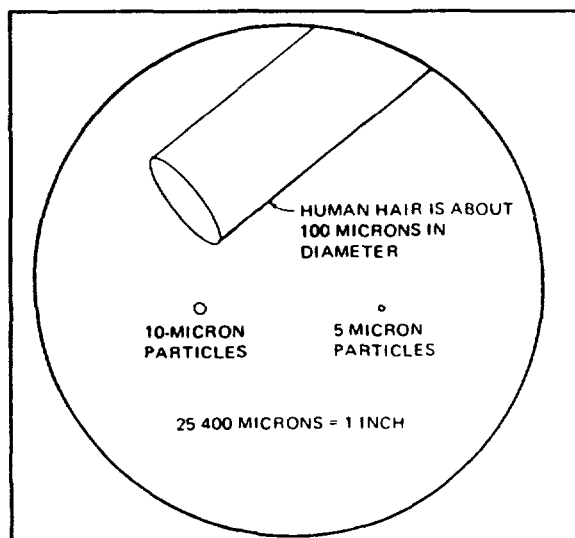

Figure 4-1. Enlargement of Small Particles and Comparison to Human Hair

Particulate matter contamination most prevalent in aircraft fuels are iron rust and scale, sand, and airborne dirt. The principal source of iron rust and scale is the corrosion in pipelines, storage tanks, and other fuel containers. Sand and dirt are particularly serious in extremely sandy or dusty areas.

Experience has shown that solid contaminants (rust and dirt) can be held well below a level of 1 milligram per liter (mg/liter) in a properly functioning fuel distribution system. If solid contaminants in fuel at aircraft dispensing points exceed 1 mg/liter when measured by the Contaminated Fuel Detector, or by laboratory analysis (ASTM Method D-2276), investigative and corrective action should be taken to improve fuel quality. If solid contaminants exceed 2 mg/liter, delivery of fuel to aircraft will be stopped and corrective measures completed prior to resumption of fueling operations.

Hose Talc can be a source of fuel contamination with some older types of hoses - especially the collapsible varieties. Talc (soapstone) material, which is applied to the interior of the hose by the manufacturer to aid the curing process, can be dislodged during normal handling and reeling operations. Prolonged soaking in fuel also tends to loosen talc. Fueling stations subjected to a reduced level of activity are particularly prone to talc

contamination. Although hose pickling is designed to prevent this type of contamination it is not always successful in doing so. Hoses manufactured to API 1529/NFPA 407 do not have a talc problem and do not need to be "pickled".

4.2.2 WATER. Free water (undissolved water) is a common contaminant of fuels and refueling personnel must be concerned with it in two forms: (1) entrained in the fuel and (2) as a separate phase (liquid water). Entrained water is found in fuels in the form of very small droplets, fog, or mist and it may or may not be visible. When large quantities of entrained water are present, the fuel will have a hazy or milky appearance. Water usually becomes entrained in the fuel when it is broken up into small droplets and thoroughly mixed with the fuel in equipment such as pumps or meters. Given sufficient time and the proper conditions, entrained water will settle and separate from aviation gasoline; however, since they are fairly dense compared to AVGAS or motor gasoline, turbine engine fuels will hold entrained water in suspension for long periods of time. Once separated and settled from the fuel, water will collect at the bottoms of tanks, pipes and other fuel system components.

Fuel will actually dissolve a small amount of water. Dissolved water is absorbed into the fuel and is not visible. The amount a fuel will hold in a dissolved state is dependent upon the fuel's temperature. A rough correlation can be made between a fuel's temperature in degrees Fahrenheit and the amount of water which can be dissolved in it. For example, a fuel at 60°F will hold approximately 60 parts per million (ppm) dissolved water, while at 30°F it will only hold 30 ppm. It is important to note that as a fuel cools down, the water which is dissolved in it at the higher temperature will come out of solution and become free water.

Free water may be fresh or saline. Free water may be in the form of a cloud, emulsion, entrained droplets, or in gross amounts in the bottom of a tank or container. Any form of free water can cause icing in the aircraft fuel system components. A Fuel System Icing Inhibitor (FSII) is added to JP-4, JP-5, and JP-8 to prevent the formation of ice in aircraft fuel systems when temperatures fall below the freezing point of water at high altitudes. Because FSII is preferentially soluble in water, prevention and elimination of water from fuel transportation and storage systems is essential. Failure to eliminate

water could result in the loss of FSII below an acceptable use limit.

Free water (water dispersed as a haze, cloud, or droplets) in fuel can be disastrous in aircraft fuel systems - particularly sea water. It can cause filter and fuel control icing, fuel quantity probe fouling, and corrosion of fuel system components. Water is also the one item essential for microbiological growth to develop in aircraft tanks.

The maximum allowable limit of free water in fuel at aircraft dispensing points is 5 ppm when tested by the Free Water Detector. A satisfactorily performing filter/separator will provide fuel containing less than 5 ppm of free water. Should the level of free water in fuel at an aircraft dispensing point exceed 5 ppm, a second sample will be taken immediately to ascertain if the second sample confirms that the free water exceeds 5 ppm. If so, fueling will be stopped until changes in procedure and equipment are effected which reduce the free water to 5 ppm or below.

4.2.3 CHEMICAL CONTAMINATION.

Chemical contamination usually results from the inadvertent mixing of petroleum products. This type of contamination affects the chemical and physical properties of the fuel and can generally be detected only by specific laboratory tests. These tests are conducted at refineries, bulk terminals, and petroleum testing laboratories. Chemical contamination is prevented by isolating fuels and providing separate handling systems. Pilots and personnel servicing aircraft will seldom be confronted with chemical or petroleum contamination and then will be able to detect it only by an unusual color, appearance or odor.

When doubts as to fuel quality cannot be resolved by application of the standard fleet test methods, fuel samples should be drawn and shipped immediately to at least one of the petroleum testing laboratories listed in Appendix B.

During transportation by truck, railroad, barge, tanker, or fleet oiler and during terminal or station storage there are frequent opportunities for contamination with other bulk petroleum products. In some instances it is not feasible to completely eliminate the possibility of some contamination occurring. The use limits for fuel chemical and physical properties listed in Appendix B of the

NATOPS Aircraft Refueling Manual should not be used to determine the acceptability of fuels from a commercial contractor. The procurement specification should be adhered to in determining acceptability of products from contractors. If the product no longer meets the procurement specification but conforms to the chemical and physical property limits in Tables I and II, a request for waiver will be submitted to NAVPETOFF together with pertinent facts concerning the circumstances and nature of the contamination. It is important to stress that the prescribed use limits are designed to serve as parameters in determining the quality of fuel in storage and not as procurement criteria. Known contamination with other products shall be limited to the percentages shown in Table 4-1.

The mixing of different grades or types of fuels is inexcusable and results from the careless operation of the fuel handling equipment and facilities. It is considered a sign of poor performance, poor management, and inattention to aviation safety by refueling personnel. All personnel must know and remember that small quantities of one fuel can seriously contaminate and render unusable another aircraft fuel. For example, the alternate use of a truck-mounted refueler for turbine fuel and aviation gasoline can contaminate aviation gasoline sufficiently to cause failure of an engine designed for high octane aviation gasoline.

4.2.4 MICROORGANISMS. Microbiological growth consists of living organisms that grow at the fuel-water interface. Fungus is the major source responsible for problems associated with microbiological contamination of jet fuels. Fungus is a form of plant life; it holds rust and water in suspension and acts as a stabilizing agent for fuel-water-sediment emulsion. It clings to glass and metal surfaces and can cause erroneous readings in fuel quantity gauging systems, sluggish fuel control operation, and sticking of flow dividers.

Microbiological growth is generally found wherever pockets of water exist in fuel tanks. Microorganism contamination appears as a brown slime-like deposit which adheres to the inner surfaces of fuel tanks. Although bacteria and fungi are present in most turbine fuels, the conditions necessary for their *growth* include water, fuel, and trace minerals. Water remains the key ingredient. Without free water there is no growth.

MIL-HDBK-844(AS)

		Product Being Handled			
		80/87	100LL 100/130	JP-4	JP-5
Contaminating Product	80/87		0.5%	5.0%	0.0
	100/130	5.0%		1.0%	0.0
	JP-4	0.5%	0.5%		0.0
	JP-5	0.5%	0.5%	10.0%	
	Diesel	0.5%	0.5%	0.5%	0.5%
	Naval Distillate	0.5%	0.5%	0.5%	0.5%

Table 4-1. Allowable Contamination with Other Products

The presence of microbiological growth in fuel being delivered to aircraft is a reliable indication of the presence of free water and the failure of fuel cleanup equipment. FSII in sufficient concentrations in the water bottoms of aircraft fuel tanks prevents the growth of micro-organisms; however, this does not alleviate the requirement for the daily removal of all water from the low point drains since this action is necessary to prevent corrosion and the deterioration of tank coatings. The growth of microorganisms and their resultant contamination is usually most severe in tropical climates where temperatures and humidities are high

4.3. COMMON SOURCES OF CONTAMINATION. Some of the most common sources of such contamination of fuel supplies are:

- a. Fuel storage tanks which contain water bottoms that cannot be completely drained.
- b. Floating roof tanks that allow the entry of rainwater and airborne dust.
- c. Pipeline water slugs that are used to separate products.
- d. Water introduced by ballasting or leaks during transport in, tanks, tankers or barges.
- e. Previously contaminated fuel being defueled from aircraft into storage tanks.

4.4 PROCEDURES FOR PREVENTING CONTAMINATION. Contamination of aircraft fuel can only be prevented by the use of proper equipment and by following proper operating procedures. Special "Retail" or "Ready Issue" fuel handling systems are to be used at all shore station aircraft refueling activities to contain and process the fuel immediately prior to issue to aircraft. These systems include an approximate ten day supply (based on normal base issues to aircraft) storage capacity. Storage tanks used in this system must have sloping bottoms, bottom suction (pick-up) and continuous recirculation through a filter/separators which removes both water and particulates. Additional filter/separators further clean and dry the fuel as it is loaded onto trucks at truck fill stands or as it enters and/or exits direct refueling or hydrant systems. Special fuel quality monitors which will actually shut off the flow of fuel if they are exposed to excessive water or particulates are used in conjunction with filter/separators at truck fill stands, on trucks and hydrant hose carts and at direct refueling stations. Proper care and operation of these systems will help assure that only clean dry fuel enters aircraft.

Even though retail fuel delivery systems are designed with multiple filtration steps, the success of these systems is dependent upon the manner in which they are operated and maintained. The pressure drops across filter/separators and monitors must be routinely observed and recorded in order to detect failures or problems. In addition, every precaution must be taken to prevent the introduction of any

particulate matter (dirt) into the fuel. All openings and connections, including refueling nozzles, must have dust-tight caps or covers which remain in place at all times except when in use.

The mixing of fuels or the delivery of the wrong fuel can be avoided only by alert and careful personnel who know and follow the proper procedures. Accidents caused by fuel mixing are solely the responsibility of fuel handling personnel. Fortunately most Navy and Marine Corp air facilities handle only two aviation fuels - F-44 (JP-5) and F-18 (AVGAS 100/130). While this situation helps to minimize the problem, it does not reduce the need for vigilance. Completely separate handling facilities and equipment for each grade and type of fuel are essential to preventing contamination.

4.5 DETERIORATION OF AIRCRAFT FUELS. The following conditions are some of the most frequently encountered situations in which some form of contamination leads to deterioration of an aircraft fuel.

Aviation Turbine Fuel

(a) Reduction in Flash Point (JP-5 and JP-8). The flash points of these fuels will be reduced when contaminated with other fuels having lower flash points.

(b) Contamination with Dirt, Rust, and Water. This is due to normal handling procedures. JP-5 and JP-8 have a greater affinity for these contaminants than AVGAS or JP-4, therefore contaminant removal is more difficult. If adequate surveillance is not practiced, contamination is almost certain to result.

(c) Contamination with Naval Distillate Fuel (F-76). This is a shipboard handling problem. Naval distillate in amounts of 0.5 percent or more may inactivate filter/separators.

Aviation Gasoline

(a) Lowering of Vapor Pressure. The change in this property is usually due to prolonged storage in vented tanks in warm climates.

(b) Loss of a Fuel's Performance Rating. The performance rating of a fuel will usually be degraded as a result of contamination with another petroleum product.

(c) Increase in Copper Corrosion. The corrosive properties of Avgas often increase as a result of storage in warm climates in tanks with water bottoms or sludge accumulations. Bacteria growing in the water bottoms and/or sludge generate hydrogen sulfide which dissolves in the fuel.

(d) Contamination with Dirt, Rust, and Water. These are due to normal handling and are not difficult to remove, utilizing settling or filtration methods.

4.6 SAMPLING OF AVIATION FUELS. Detailed information on sampling practices and techniques is contained in the American Society for Testing and Materials (ASTM) Standard Practice for Manual Sampling of Petroleum and Petroleum Products, ASTM D 4057. All activities which handle aviation fuel should have a copy of this document. It is available directly from ASTM:

American Society for Testing and Materials
1916 Race Street
Philadelphia, PA 19103-1187

Telephone: 215-299-5400
Telefax: 215-977-9679

This document is also available from:

Standardization Documents Order Desk
Bldg 4D
700 Robbins Avenue
Philadelphia, PA 19111-5094

MIL-HDBK-844(AS)

(This page intentionally left blank.)

CHAPTER 5

FLEET QUALITY SURVEILLANCE TESTS

5.1 GENERAL. Fleet activities must monitor the fuel they issue to aircraft for particulate and free water contamination and fuel system icing inhibitor (FSII) content. In some special situations, it may also be necessary for activities to monitor the conductivity of their fuel. This chapter describes the test equipment and general procedures used to monitor these fuel properties.

5.2 PARTICULATE CONTAMINATION. The Contaminated Fuel Detector (CFD), [sometimes referred to as the "AEL MK III"], procured under specification MIL-D-22612, is a portable unit for use in the field and aboard ship to determine the solid contamination existent in aviation fuels. The instrument has a range of 0-10 mg/liter of solids. Currently, there are two versions of this detector available: The regular CFD, NSN 6630-00-706-2302, and the Combined Contaminated Fuel Detector (CCFD), NSN 6640-01-013-5279, which includes a built-in FWD Viewer Kit. Current procurements are for the CCFD only.

5.2.1 CFD Test Technique. A sample of fuel to be tested is obtained in the sample bottle provided. This fuel is filtered through two membrane filters (NSN IH 6630-00-877-3157) placed in series. The solid contaminants will be collected on the top filter. A light is shown through each filter and a meter measures the decrease in transparency of the filters due to the trapped solids. Use of two filters eliminates errors due to variations in color of different fuels. A calibration chart is provided to convert the meter readings to contamination levels in mg/liter. The special filters which are used to calibrate the unit are available from the Navy Ships Parts Control Center, Mechanicsburg, PA under NSN IH 6630-00-849-5288.

It should be recognized that this instrument is only a secondary standard and does not replace the requirements for periodic laboratory analysis, but supplements the laboratory analysis. Extensive field tests have demonstrated that the calibration curve furnished with this unit is valid for the majority of fuel samples, but there are occasional samples which do not fit the normal pattern. It may become

necessary to establish a new or modified calibration curve in a few unusual cases where the contaminants in a particular system do not follow normal patterns. Duplicate samples sent to the laboratory for gravimetric analysis will give a cross check on the instrument and quickly pinpoint these unusual systems. In addition, CFD operators are requested to visually inspect the millipore filter pads for any large particles or unusual spots and stains which may cause erratic or erroneous CFD results. Any such situations which frequently reoccur should be reported to the NAWCADTRN (Code PE33) at the following address:

Naval Air Warfare Center
Aircraft Division, Trenton
Attn: Code PE33
P.O. Box 7176
Trenton, NJ 08628-0176

Telephone Numbers:

DSN 442-7859 or commercial 609-538-6859
DSN 442-7929 or commercial 609-538-6929

Telefax Numbers:

DSN 442-7562 or commercial 609-538-6562
DSN 442-7604 or commercial 609-538-6604

Message Address:

NAVAIRWARCENACDIV TRENTON
NJ//PE33// (Message must include
Accounting Symbol and Program Designator
Code (AS/PDC) NA-CRAFAA immediately
after the list of addressees.)

This unit provides operating activities with a capability of determining the solids content of aviation fuels. While the unit is comparatively simple to use, it is a precision instrument and should be treated accordingly. It is believed that the maximum value of this unit can best be realized by placing it in the hands of the person responsible for quality control and inspection of aviation fuels for the activity.

The accuracy and value of a unit of this nature will depend upon the personnel operating it. If the

MIL-HDBK-844(AS)

results are to be valid, the fuel samples must be truly representative and the whole operation conducted so that nothing extraneous is introduced. Normally it will prove easier to bring the fuel sample to the instrument than the instrument to the fuel.

5.2.2 CFD Operating Procedure. Complete details on the operation of the detector are contained in the technical manual which is supplied with each detector. The following procedure applies to all CFD's in general, and may be used in the event the manual is missing.

- (a) Turn the detector on and allow to warm up for 2-3 minutes.
- (b) Ensure the vacuum receiving flask is empty and the drain cock closed.
- (c) Place two membrane filters, one on top of the other, in the bottle receiver.

Note: The membrane filters are packaged with blue paper between the filters. Dispose of the blue paper dividers, do not use them for filtration.

- (d) Fill the sample bottle provided with 800 milliliters of fuel to be tested. Fit the bottle receiver onto the top of the sample bottle. Plug the grounding wire from the bottle receiver into the receptacle provided on the CFD.
- (e) Turn the vacuum pump on. Holding the bottle receiver snug against the sample bottle, invert the assembly and fit the bottle receiver into the top of the vacuum flask.
- (f) Gently swirl the fuel in the sample bottle while the fuel is being filtered to ensure any contaminants are washed down with the fuel through the filters. The movement of the bottle should also be sufficient to vent the bottle, allowing air bubbles into the bottle.
- (g) When the all of the fuel has passed through the filters, turn the pump off, and remove the sample bottle from the bottle receiver.
- (h) Drain the fuel from the vacuum receiving flask into an appropriate container for disposal.

- (i) With no filter in the tray, and the tray fully inserted, adjust the panel meter to a reading of 600 milliamperes.
- (j) Place a small amount of pre-filtered fuel in the wetting dish depression provided on the top of the detector. Open the bottle receiver and remove the top membrane filter with forceps. Gently lay the filter in the wetting dish so that the entire filter is wetted with fuel.
- (k) Place the wetted filter into the filter tray, insert the tray into the photocell housing and record the milliammeter reading. Remove the filter from the tray.
- (l) Confirm the meter still reads 600 milliamperes with no filter in place. Repeat the wetting process with the second membrane filter, and place it in the filter tray. Insert the tray in the photocell housing and record the milliammeter reading. Remove the filter from the tray and dispose of both filters.
- (m) Subtract the lower of the milliammeter readings from the higher allocated set. Locate the change in reading value on the vertical left axis of the calibration chart, and read the corresponding value of contamination (where the change in reading *intersects the curve*) in milligrams per liter from the horizontal bottom axis of the chart. Report the contamination in milligrams per liter.

Detailed instructions or assistance in operating or calibrating a specific model detector are available from NAWCADTRN at the address and telephone numbers listed in paragraph 5.2.1 above.

5.2.3 Alternate Methods. An alternate system for the field detection of particulate contaminants in aviation fuel, which is approved for use at shore facilities only, is the USAF's system of in-line sampling coupled with a visual assessment technique. Details on this method and the necessary equipment can be obtained from USAF Technical Manual T.O. 42B-1-1, Quality Control of Fuels and Lubricants, paragraph 5 - 27 through 5 - 46, copies of which are available from the NAVAIRHQ (AIR-5363). Another version of this visual particulate testing

technique which is also approved for use at shore activities is contained in the US Army's Aviation Fuel Test Kit.

5.3 WATER CONTAMINATION. The Viewer Kit, Free Water Detector (FWD) procured under Military Specification MIL-D-81227, NSN 6640-00-999-2786, is a simple, small unit for use in the field or the laboratory to determine the free water content of aviation fuels. It was designed for use in conjunction with the CFD and will accurately measure undissolved water in jet fuels. The current versions of this device are sometimes referred to as "AEL MK II" while an earlier version of was designated "AEL MK I". Many of the CFD's now include free water detector capability and may be used instead of a separate FWD.

5.3.1 FWD Test Technique. A sample of fuel to be tested is passed through a chemically treated filter pad (NSN 9L 6640-00-999-2785) by using the filter holder and vacuum pump of the CFD or CCFD. The chemical on the pad is sensitive to any free water in the fuel, producing a fluorescent pattern readily visible under ultra-violet light. After filtration, the pad is examined under the ultra-violet light contained in the FWD or CCFD. The amount of free water in the fuel sample is determined by the intensity of fluorescence on the test pad. Visual comparison is made with a series of standards representing known quantities of water. Standards, which are available under NSN 9L 6640-00-999-2784, tend to deteriorate with time and exposure to ultra-violet light. They should, therefore, be replaced every 6 months.

5.3.2 FWD Operating Procedure.

- (a) Turn the detector on and allow to warm up for 2-3 minutes.
- (b) Ensure the vacuum receiving flask is empty and the drain cock closed.
- (c) Place the 47mm free water pad into the bottle receiver.
- (d) Fill the sample bottle provided with 500 milliliters of fuel to be tested. Shake the sample vigorously for about 30 seconds. Fit the bottle receiver onto the top of the sample bottle. Plug the grounding wire from the bottle receiver into the receptacle provided.

- (e) Turn the vacuum pump on. Holding the bottle receiver snug against the sample bottle, invert the assembly and fit the bottle receiver into the top of the vacuum flask.
- (f) Gently swirl the fuel in the sample bottle while the fuel is being filtered to ensure any contaminants are washed down with the fuel through the filters. The movement of the bottle should also be sufficient to vent the bottle, allowing air bubbles into the bottle.
- (g) When the all of the fuel has passed through the filters, turn the pump off, and remove the sample bottle from the bottle receiver.
- (h) Drain the fuel from the vacuum receiving flask into an appropriate container for disposal.
- (i) Remove the free water pad from the bottle receiver and place in the free water detector slide. Insert the slide into the free water detector and turn on the ultra-violet light.
- (j) Visually compare the fluorescence on the free water pad with that on the free water standards inside the detector. The free water standards provided show the fluorescence at 0, 5, 10 and 20 parts per million (ppm) of free water. Estimate the corresponding free water content by fluorescence intensity and droplet pattern on the free water pad.

Note: If the result is greater than 20 ppm, take a new sample half the volume of the original (250 ml), read the fluorescence, and double the value.

- (k) Report the free water results in parts per million.

The free water test utilizing the FWD should be executed as soon as possible following sampling since the results are directly affected by any temperature change in the fuel sample. This test, conducted by the sampling activity, is the only free water determination now required and is more accurate than can be obtained from a sample sent to a laboratory.

5.3.3 Alternate Method. The Aqua Glo Water Detector (ASTM method D-3240) is an approved alternate instrument for determining the free water

MIL-HDBK-844(AS)

content of aviation fuels using 25mm pads. This instrument is included in the USA's Aviation Fuel Test Kit.

5.4 FUEL SYSTEM ICING INHIBITOR (FSII) CONTENT. The B/2 Anti-icing Additive Refractometer and Test Kit (NSN 6630-01-165-7133) provides a simple and accurate means of determining the FSII content of aviation fuels.

5.4.1 B/2 Test Technique. A sample of fuel to be tested is placed in a separatory funnel along with a small quantity of tap water. After agitation, a few drops of the water layer are placed on the cell of the refractometer and a reading is taken directly from the appropriate scale. During this process the FSII is "washed" from the fuel and collects in the water layer. Since the FSII content of the water changes its refractive index, the extent of this change is used to determine the concentration of FSII in the fuel.

5.4.2 B/2 Operating Procedures. Detailed instructions are provided with the test kit, the following procedure summarizes the operation of the kit.

- (a) Procure 1 pint of fuel to be tested in a clean and dry container.
- (b) Assemble the ring stand. Fill an aluminum dish one half full of water. Tap water is satisfactory.
- (c) Pretreat the graduated cylinder and separatory funnel with the test fuel. Place a small amount of fuel in the cylinder, swirl to wet the sides of the cylinder, then pour the fuel out. With the drain cock closed, place a small amount of fuel in the separatory funnel and swirl to wet the sides of the funnel. Pour the fuel out of the top of the funnel, do not use the drain cock for this step.
- (d) Transfer exactly 160 milliliters of the fuel from step (a) to the separatory funnel. (Some kits may have a separatory funnel with a line marking the 160 milliliters capacity instead of a graduated cylinder. Fill to that line if the kit is so equipped).
- (e) Using one of the piston pipets contained in the set, add exactly 2 milliliters of water to

the separatory funnel from the aluminum dish supply. Cap the funnel and shake vigorously for 3 minutes. Swirl funnel and place in ring stand.

- (f) Open the cover of the refractometer's window and make sure that it is clean. Apply several drops of water to it from the aluminum dish supply. Close the cover and observe through the eye-piece the location of the shadow in the viewer. Remove the plastic rod from the instrument's base and adjust the set screw (in the base) if necessary, so that the shadow line intersects the zero line of the scale. Clean and cover the refractometer's window.
- (g) Carefully rotate the separatory funnel's drain cock so that a trickle of fluid can be taken in a clean, dry aluminum dish. Two to three drops will be sufficient.
- (h) Using the same technique as step (f), transfer the fluid from the aluminum dish to the refractometer's window. Close the cover and observe the position of the shadow line. If testing JP-5 with DiEGME, read the scale on the left. If testing JP-4 with EGME, read the scale on the right. Record results.
- (i) Properly dispose of the fluids. Wash the apparatus in soap and water and properly dry all items. Treat the refractometer as an optical instrument and avoid damage to the lens and window elements.

5.5 CONDUCTIVITY. The EMCEE Fuel Conductivity Meter (NSN 6630-01-115-2398) provides a simple method of measuring the electrical conductivity of aviation fuel which is occasionally necessary with JP-4 and JP-8 fuels which have SDA injected in them. A sample of the fuel to be tested is extracted into a sampling bottle or can. The meter's probe is inserted into this fuel sample and its conductivity is read directly off of the meter. Detailed instructions for the calibration and use of this meter are available in USAF Technical Manual T.O. 42B-1-1, Quality Control of Fuels and Lubricants, paragraph 5-14, copies of which are available from the NAVAIRHQ (AIR-5363).

CHAPTER 6

SAFETY IN FUEL HANDLING OPERATIONS

6.1 INTRODUCTION. This chapter identifies and explains the more hazardous elements of aviation fuel handling with particular emphasis on electrostatic phenomena and its effects on fuel operations. The better these hazards are known and understood by refueling personnel, the better they will be at avoiding or correcting unsafe situations.

The development of safe and efficient fuel handling and aircraft refueling procedures is a continuously evolving process. Scientific investigations are coupled with actual field experience in order to establish the safest and simplest procedures possible. One of our most important sources of information in this process can be, and often is, the investigation of field accidents or problems. It is therefore extremely important that knowledgeable personnel be involved in accident investigations especially whenever explosions or fires have occurred. This section is designed to provide a basic education on the subject of the hazards of fuel handling; however, it is advisable to request the assistance and participation of experts whenever major fuels accidents are being investigated to insure that correct conclusions are drawn. NAVAIR and NAVPETOFF will assist in the identification of appropriate experts for any investigation.

6.2 ABNORMAL FUEL OPERATIONS. There shall be no departure from the requirements and operating procedures contained in the NATOPS Aircraft Refueling Manual, NAVAIR 00-80T-109, or of the activity fuel instruction without the full cognizance of the FMO. When in doubt, operators should contact the FMO. Furthermore, fuel operators should discontinue any fuel operation which does not appear to be progressing in a normal fashion (i.e. appears to be taking much longer than would normally be expected, pressures are too high, etc.) and immediately notify the FMO of his apprehension(s). This is not to say that a special or one time operation should not be conducted, but rather that it should be closely monitored and performed under the surveillance of the most knowledgeable fuel personnel available.

6.3 FIRE AND EXPLOSION. Three factors are necessary for combustion of fuel: fuel in the form of vapor; oxygen from the air; and sufficient heat to raise a material to the ignition temperature. These three factors must all be present to produce a fire. The removal of any one of the factors will prevent combustion. Since all refueling or defueling operations contain two essential factors, fuel and air, the elimination of sources of ignition is the most effective way of preventing fire. Reducing or controlling the generation of fuel vapor is extremely important in preventing fires and explosions. See the NATOPS manual for specific procedures which reduce the generation of fuel vapor

6.3.1 FLAMMABLE FUEL-AIR MIXTURES. The probability of a fuel vapor-air mixture being flammable is dependent of the vapor pressure and flash point of the product. Table 6-1 provides Reid vapor pressures for aviation fuels. These properties may be used to classify refined products into low, intermediate and high vapor pressure categories.

6.3.1.1 LOW VAPOR PRESSURE PRODUCTS. These materials usually have flash points above 100°F (38°C) such as JP-5, JP-8 commercial Jet A, diesel fuel, kerosene, furnace oil, safety solvents, etc. Since these products are normally handled at temperatures well below their flash points, no hazard is involved because no flammable vapors will develop. However, conditions for ignition may exist if these products are handled at temperatures above their flash points, if they are mixed with intermediate or high vapor pressure products, are loaded into tanks where flammable vapor may be present from previous usage (switch loading), or are splash loaded.

MIL-HDBK-844(AS)

Vapor Pressure Category	Fuel Type	Fuel Grades	NATO Code	Vapor Pressure, psi (kPa)	
				Minimum	Maximum
High	AVGAS	100LL (100, 80/87, 100/130, 115/145)	F-18	5.5 (38.5)	7.0 (49.0)
Intermediate	Wide-Cut Turbine Fuel	JP-4 (Jet B)	F-40	2.0 (14)	3.0 (21)
Low	Kerosene Turbine Fuel	JP-8 (Jet A-1, Jet A)	F-34	0.0	0.1 (0.7)*
	High Flash Kerosene Turbine Fuel	JP-5	F-44	0.0	0.035 (0.245)*

* These are approximate values. The vapor pressure of kerosene fuels is indirectly limited by the flash point.

Table 6-1. Vapor Pressures of Aviation Fuels

6.3.1.2 INTERMEDIATE VAPOR PRESSURE PRODUCTS. These materials may create flammable mixtures in the vapor space at some normal handling temperatures. Examples of these products are JP-4, commercial Jet B, and solvents such as xylene, benzene and toluene.

6.3.1.3 HIGH VAPOR PRESSURE PRODUCTS. These products are so volatile that under equilibrium conditions at normal handling temperatures (between 35°F and 100°F (2°C and 38°C)) they produce a "too rich" mixture to be flammable in a restricted vapor space. When high vapor pressure products are loaded into gas free tanks, the vapor space will pass through the flammable range, but vapor just above the surface becomes over-rich almost immediately. It is possible, in this and other tank filling operations, that a stratified layer of flammable vapor will be raised to the top of the tank by the filling process. Products which do not create flammable vapor mixtures in the normal handling temperature range could do so under extreme temperature conditions. Figure 6-1 which shows the approximate correlation of Reid Vapor Pressure (Rvp) and product temperature to the flammable range, may be useful in determining whether a flammable vapor-air mixture is likely to exist. The above information is important to understand from the safety standpoint, but in actual practice individual flammability determinations will not be made by operators. All fuel handling operations, regardless of the product, are conducted in accordance with established procedures which are designed for the most hazardous product or

combination thereof.

The mixing of different grades of aviation turbine fuels in ground handling operations is held to the minimum level practicable; however, all fuel defueled (removed) from aircraft is almost invariably a mixture of grades. For this reason defueled fuel must be handled as a separate grade of fuel designated "JP" or "jet fuel" and not "JP-5", "JP-8", "JP-4" or the equivalent analogous NATO Code Number until laboratory testing determines actual grade.

6.3.2 FLAME SPREAD RATES. The Naval Research Laboratory (NRL) has investigated the relationship between a fuel's flash point, temperature, and the speed with which a flame will spread across its surface. The results of this investigation are summarized in Figure 6-2. The data clearly disclosed a dramatic change in the behavior of a fuel once it has been heated 20 to 30°F above its flash point - the flame spread rate greatly increases. This is an important factor to keep in mind when handling the various types of fuels or aircraft containing them. If fuel spills onto a hot surface such as a flight deck, it will quickly assume the temperature of that surface and behave accordingly. Avoid introducing fuels into environments where the ambient or surface temperature exceeds the flash point of the fuel by greater than 20°F. Figure 6-3 illustrates the effects on flash point of mixing the different types of turbine fuels.

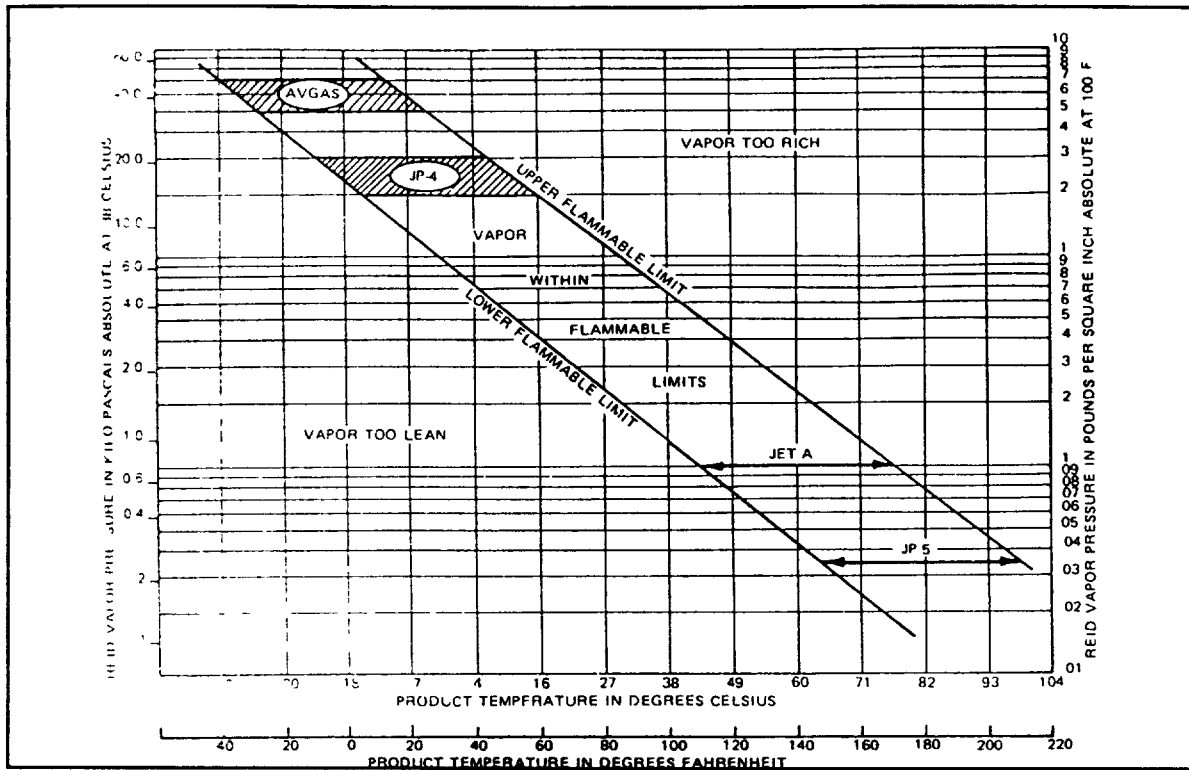

Figure 6-1. Relationship Between Temperature, Rvp, and Flammable Limits of Petroleum Products at Seat Level

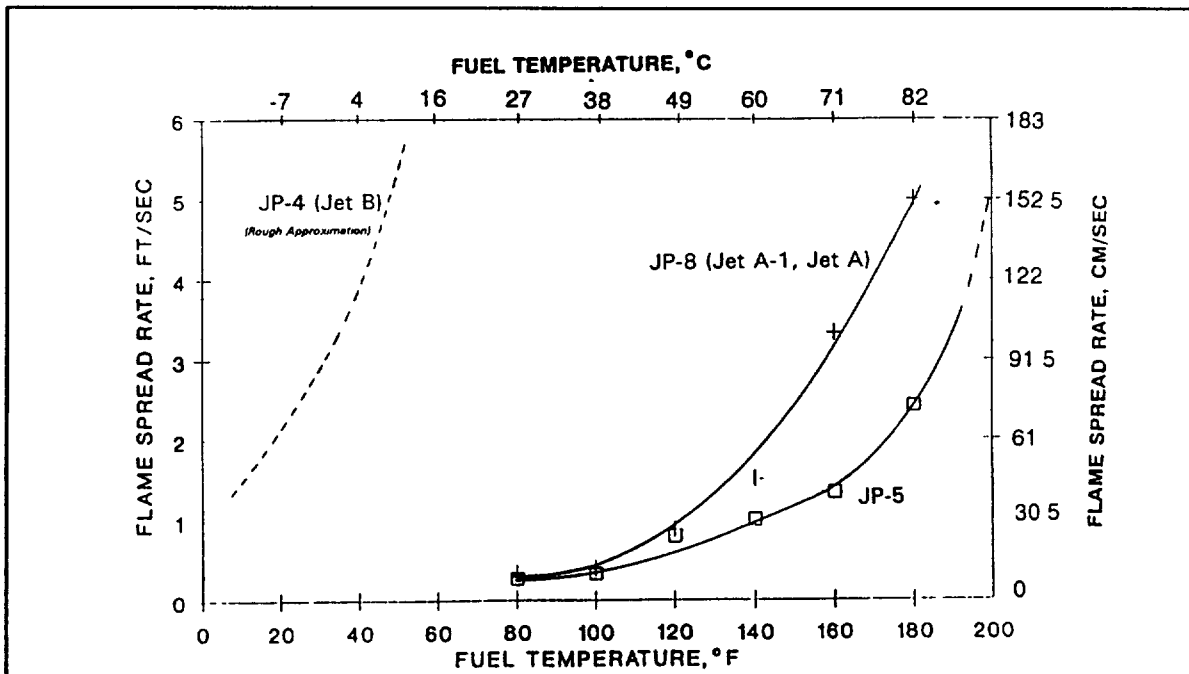

Figure 6-2. Flame Spread Rate Versus Fuel Temperature.

MIL-HDBK-844(AS)

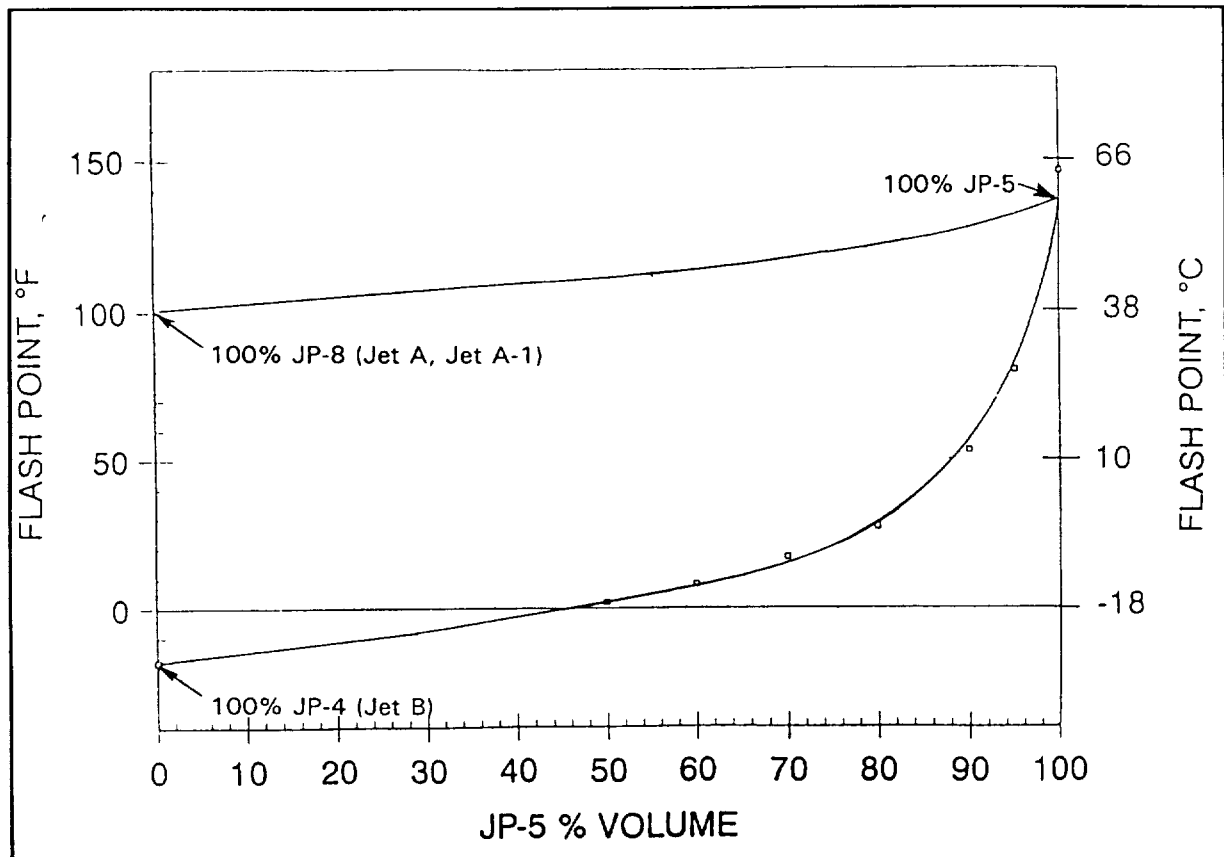

Figure 6-3. Flash Point of Turbine Fuel Mixtures.

NRL has also demonstrated a relationship between a fuel's flash point, temperature, and the degree of difficulty in extinguishing a fire. Similar to flame spread rates, the investigators found that the fire was significantly more difficult to extinguish if the temperature of the fuel was $\geq 20^{\circ}\text{F}$ above the fuel's flash point.

6.4 SOURCES OF IGNITION. There are many potential ignition sources, but the ones most likely to be present during the refueling and defueling operations are:

- a. Static electricity spark
- b. Operating engines
- c. Arcing of electrical circuits
- d. Open flames
- e. Electromagnetic energy
- f. Hot surfaces or environment

6.4.1 STATIC ELECTRICITY. Static electricity is the term applied to the accumulation of electrical charges on materials and objects and the subsequent recombination (relaxation or discharge) of these charges. Static charges are created when two materials (or objects of differing composition) are rubbed or passed across each other. Negative charges (electrons) migrate to one material while positive charges accumulate in the other. For significant charges to be developed, the bodies must become and remain insulated from one another so that the electrons, which have passed from one surface to the other, become trapped when separation occurs. Insulation may occur through complete physical separation of the bodies or because at least one of the bodies is a poor conductor. The development of electrical charges may not of itself be a potential fire or explosion hazard. There must be a discharge or sudden recombination of separated positive and negative charges (sparking). In order for static to be a source of ignition four conditions must be fulfilled:

- a. There must be an effective means of static generation.

b. There must be a means of accumulating the separated charges and maintaining a suitable difference of electrical potential.

c. There must be a spark discharge of adequate energy.

d. The spark must occur in an ignitable mixture.

6.4.1.1 INTERNAL STATIC. Since the mid 1950s, nearly 200 fires and explosions which occurred during aircraft fuel handling operations have been attributed to static discharges. Of all possible sources of static build-up which could occur during fueling and defueling operations, the real danger lies in those electrostatic charges generated by the movement of the fuel itself

6.4.1.1.1 Charge Generation. Internal static charges can be generated by the following:

a. **FILTRATION.** Whenever a hydrocarbon liquid, such as jet fuel, flows past any surface, a potential difference (electrical charge) is generated between the liquid and the surface. Filtration media provide tremendous amounts of surface area upon which such charge separation can take place as the fuel moves through them. For this reason filter/separators and fuel monitors are prolific charge generators.

b. **SPLASH FILLING.** Charges may be generated by splashing or spraying of a stream of fuel as it enters a tank, by the disturbance of the water bottom by the incoming stream, or by pumping substantial amounts of entrained air with the fuel. The amount of charge generated by splash filling depends on the configuration of the tank, the fuel inlet, the conductivity, foaming tendency and velocity of the fuel, and the existence in the fuel of pro-static agents. Pro-static agents are materials that greatly increase the charging tendency of the fuel without a corresponding increase in conductivity. Water, for example has been found to be an efficient pro-static agent.

c. **FOAM FILLED AIRCRAFT TANKS.** During the 1970s the USAF and Navy began placing polyurethane foam into aircraft tanks for fire protection purposes. The foam acts like a three-dimensional flame arrestor and suppresses ignition of fuel vapor by incendiary projectiles. Unfortunately

the polyurethane foam did not prove durable and was replaced with a polyester foam which has an approximately 10 times greater tendency to create a static charge when fuel flows across it. The designs of several USAF aircraft incorporate splash filling of their tanks through this foam medium. As a result, several of these aircraft have experienced small flash fires/explosions during refueling operations. While the damage to the aircraft is limited, repairs are usually expensive. Fortunately US Navy and Marine Corps aircraft do not incorporate splash filling in their tanks and have subsequently not had similar problems.

6.4.1.1.2 Charge Accumulation. Since hydrocarbon fuels are relatively poor conductors of electricity, the charges built up in them relax (dissipate) slowly. It is therefore possible to pump highly charged fuel into a tank or aircraft. Once the fuel is in the tank, the unit charges of similar sign within the liquid are repelled from each other toward the outer surfaces of the liquid, including not only the surfaces in contact with the tank walls, but also the top surface adjacent to the air space. It is this "surface charge" that is of concern in fuel operations. If fuel were a perfect insulator the charge would remain indefinitely. However, there are no perfect insulators and the isolated charges in the fuel are in a continuing process of leaking away to recombine with their counterparts on the tank shell (having migrated there from the filter/separator on the dispenser via the bonding cable). This leakage characteristic is called relaxation. Under the continuous influence of a charge generating mechanism, the accumulated voltage on the fuel (an insulated body) continues to increase. As the voltage becomes greater, the rate at which the charge will leak through the insulation (the fuel) to the tank shell will increase. At some voltage (if lower than the sparking potential) the leakage of the charge will be equal to the rate at which charge is being placed on the fuel and a stabilized condition will exist.

6.4.1.1.3 STATIC DISCHARGE OR IGNITION. When sparking potential is reached before stabilization, a spark discharges a portion of the fuel surface, the voltage immediately drops, and the entire process is resumed from the beginning. The fact that a spark occurs does not mean that a flammable mixture will ignite. For ignition, there must be sufficient energy transferred from the spark to the surrounding fuel vapor. Many factors such as material and shape of electrodes, the space of the

MIL-HDBK-844(AS)

gap, temperature, and pressure could decrease the availability of stored energy to the flammable mixture. The worst condition is a spark discharge from a floating, suspended, or attached but unbonded object in the tank since the entire amount of stored charge is released in a single discharge.

6.4.1.1.4 CONTROL MEASURES. The sizable static charges built up in fuel as it passes through filtration media can be effectively reduced to safe levels by passing the fuel through a relaxation chamber. Such devices slow down the velocity of the fuel and bring it into contact with metal surfaces bonded to the filter housing thus giving the fuel both the time (a minimum of 30 seconds after it has passed through the filter) and the means to have its static charges recombine with those produced on the filter medium. This is the control approach used by the US Navy and Marine Corps in fuel handling equipment. Relaxation chambers can be either an actual tank or a large diameter pipe; the exact dimensions of the chamber must be determined from the maximum flow rate of the system. Tanks used for relaxation chambers must be baffled to avoid a tunnelling effect as fuel enters and leaves. The relaxation chamber in a system does not negate the need for bonding the refueling equipment to the aircraft. The chamber only reduces the static charge on the fuel to safer levels - It does not completely eliminate the charge.

The USAF has taken a different approach to handling static charges generated in fuels. SDA is injected into JP-4 and JP-8 fuels to increase the fuel's conductivity and therefore the speed with which the static charges are relaxed. If the fuel's conductivity is high enough, charges will be sufficiently reduced prior to the fuel exiting the filter housing. Unfortunately, SDAs have serious side effects. The primary problem is that certain SDAs have a negative effect on the water separation and removal characteristics of the fuel. This is of particular concern since JP-5 often comes into contact with water throughout the supply system. The second problem with SDAs is that they tend to be lost in the supply system and must be periodically reinjected thus requiring frequent monitoring of the fuel's conductivity level as well as facilities for reinjection.

The NATOPS Aircraft Refueling Manual contains a detailed list of procedures and actions which can be followed to help insure the safe relaxation of internal static charges.

6.4.1.2 EXTERNAL STATIC. Accident records indicate that the fire and explosion hazard from exterior static discharges during fuel operations is minimal; however refueling personnel must be aware of the possible sources of external static and take proper precautions to further minimize and eliminate its impact.

6.4.1.2.1 Charge Generation. There are five possible sources of exterior electrostatic charges on aircraft:

- a. Movement of airborne charged particles, e.g. snow, ice crystals, dust or smoke.
- b. Aircraft engines turning or other systems operating on the aircraft
- c. Cloud induced fields. (The heavily charged clouds of an electrical storm set up an electrostatic field over a large area of the earth's surface below them. The "field" induces static on the earth, aircraft, refueler, etc.)
- d. Movement of a charged object onto aircraft. (Static from over-the-wing nozzles - probably transferred from personnel while nozzle was insulated from both refueler and aircraft - prior to the initiation of fuel flow fits into this category.)
- e. Lightning. Electrostatic currents resulting from both distant as well as direct lightning strikes are orders of magnitude more severe than those from any other source.

6.4.1.2.2 Charge Accumulation and Dissipation. The amount of electrostatic charge which can accumulate on an insulated body, such as a rubber-tired aircraft or refueler, depends upon the rate at which the static is generated and the resistance of the paths by which the charge leaks off. On concrete parking aprons the tire-surface contact-resistance paths will provide sufficient discharge capability to prevent the accumulation of static charges. Asphalt, especially when dry, is a much better insulator than concrete and therefore dissipates static charges much more slowly. The extremely large static charges which have accumulated on aircraft during flight are dissipated in short periods of time after landing; but fueling operations must not commence until adequate time has elapsed to assure the dissipation of accumulated charges. Turning engines and helicopter rotors are also strong static

generators and sufficient time must be allowed after they have been turned off for the charges created to dissipate. Since most refueling operations are conducted on concrete, less than a minute is needed to completely relax these charges; however waiting three minutes will insure safety. Any refueling operations conducted on asphalt or any surface other than concrete should be classified as abnormal and thus subject to special procedures including earthing (grounding) of the aircraft and refueler. Any refueling operations conducted with aircraft engines or other equipment operating (with the exception of fuel system switches) must be considered abnormal and also subject to special procedures including earthing.

6.4.1.2.3 Control Measures for External Static During normal fueling and defueling operations on concrete surfaces, tire-surface contact can be relied upon to prevent the accumulation of static charge. Specific procedures to be followed are contained in the NATOPS Aircraft Refueling Manual.

6.4.2 OPERATING ENGINES. The operation of aircraft engines, automobile engines, or other internal combustion engines can provide sources of ignition. Ignition of vapors may occur through the arcing of distributor points, arcing at spark plugs, loose spark plug wires, hot engine exhaust piping, and backfiring. The starting of engines with their susceptibility to false starts, malfunctions and fires during the cranking phase, are likely sources of fuel vapor ignition. Stopping an engine, as opposed to leaving it running, is more apt to provide an ignition source because of possible dieseling, backfiring or malfunctioning when the engine's ignition is turned off.

6.4.3 ARCING OF ELECTRICAL CIRCUITS. Arcing of electrical circuits is another common source of ignition in fuel handling operations. Sparks may occur when battery terminals are connected or when an electrical switch is operated. Other examples of sparks from electrical circuits are: arcing of generator brushes, arcing of welding machine brushes, arcing of brushes on electrical motors and tools, and tools, and the arcing which occurs in short circuits. Defective aircraft electrical circuits have been known to melt the plastic coatings on bonding and earthing cables during refueling operations; cables have even turned cherry-red, burned and disintegrated, moments after the earth cable was attached to the earth point. Static

earthing cables are not adequate protection against such stray currents.

6.4.4 OPEN FLAMES. Open flames and lights are obvious sources of ignition. These include cigarettes, cigars, pipes, exposed flame heaters, welding torches, blow torches, flare pots, gasoline or kerosene lanterns, matches, cigarette lighters, and others. Similar to this hazard of open flames is that of standard electric light bulbs. Should any of these bulbs break, the filament would become hot enough to ignite a vapor-air mixture and cause a fire or explosion.

6.4.5 ELECTROMAGNETIC ENERGY. High Frequency transmitting equipment, including radar, mounted in aircraft or mobile units, automotive equipment, or on the ground can provide sufficient electromagnetic energy to ignite fuel vapors. For this reason, refueling or defueling operations should not be conducted within 100 feet of operating airborne radar equipment, or within 300 feet of operating ground radar equipment installations.

6.4.6 HOT SURFACES OR ENVIRONMENT. Fuel or fuel vapors can come into contact with surfaces sufficiently hot to cause autoignition of the fuel or vapor. Examples are; a high pressure fuel leak hitting a hot brake or metal particles from a welding, filing or cutting operation contacting the fuel vapor. Some areas of the aircraft, such as the bombay, may provide a hot enough environment for autoignition of any fuel which may leak into the area. Although actual autoignition temperatures may vary a great deal depending on the specific fuel involved and its environment, the minimum temperatures can safely be assumed to be above 460°F for turbine fuels and 800°F for aviation and other gasolines.

6.5 EXTINGUISHMENT. Although the Air Station's Crash Crew (Crash, Fire, and Rescue) or Ships Crash Crew has prime responsibility for fire fighting, all fueling handling personnel should be aware of the basic principals involved in extinguishing fires as well as the equipment used. They should also make certain that appropriate fire fighting equipment, in good condition, is readily available whenever and wherever fuel handling operations are being conducted. For maximum effectiveness and safety, fire extinguishers must be operated in accordance with the specific procedures developed for each individual type. The following

MIL-HDBK-844(AS)

information has been extracted from the NATOPS U.S. Navy Fire Fighting and Rescue Manual, NAVAIR 00-80R-14, and is presented here to provide refueling personnel with general information on fire chemistry, classification, and methods of extinguishment.

6.5.1 Fire Chemistry. For many years, fire was considered to be the product of a combination of three elements: fuel, an oxidizing agent, and temperature. Research in the past 30 years has indicated the presence of a fourth critical element. The fourth element is the chemical chain reaction that takes place in a fire and allows the fire to both sustain itself and grow. For example, in a fuel fire, as the fire burns, fuel molecules are reduced within the flame to simpler molecules. As the combustion process continues, the increase in the temperature causes additional oxygen to be drawn into the flame area. Then, more fuel molecules will break down, enter into the chain reaction, reach their ignition point, begin to burn, cause a temperature increase, draw additional oxygen, and continue the chain reaction. As long as there is fuel and oxygen and as long as the temperature is sustained, the chain reaction will cause the fire to grow.

6.5.2 Classification of Fires.

6.5.2.1 Class A Fires. Class A fires (burning wood and wood products, cloth, textiles and fibrous materials, paper and paper products) are extinguished with water in straight or fog pattern. If fire is deep seated, aqueous film forming foam (AFFF) can be used as wetting agent.

6.5.2.2 Class B Fires. Class B fires (gasoline, jet fuels, oil, and other flammable/combustible liquids) are extinguished with AFFF, Halon 1211, purple-K-powder (PKP), and carbon dioxide (CO₂).

6.5.2.3 Class C Fires. A Class C fire involves energized electrical equipment. Extinguishment tactics are: deenergize and treat as a Class A, B, or D fire; attack with application of non-conductive agents (CO₂, Halon, PKP); or attack with application of fresh or salt water in fog patterns maintaining nozzle at least 4 feet from the energized object.

6.5.2.4 Class D Fires. Class D fires (combustible metals such as magnesium and titanium) are extinguished with water in large quantities such as high velocity fog. When water is applied to burning

Class D material, there may be small explosions. The firefighter should apply water from a safe distance or from behind shelter.

6.5.3 Fire Extinguisher Types, Agents, and Methods of Application. The best application technique varies with the type of extinguishing agent and associated hardware. Some fire extinguishers deliver their entire quantity of extinguishing agent within 10 seconds while others are designed to be operated for 30 seconds or longer. The agent must be applied correctly at the outset since there is seldom time to experiment. Using a portable extinguisher at too close a range may scatter the fire and using it at a distance beyond the effective range will simply waste the extinguishing agent.

WARNING

- Firefighters must use caution in fighting fuel fires and be prepared to back out well before the extinguisher contents are exhausted.
- Halon, PKP, and CO₂ are all rapidly dissipated and no vapor sealing property is developed, so the fuel is always subject to reignition. Discharge should be continued for a short time after the flames are extinguished to prevent possible reflash and to cool any ignition sources in or near the fire.
- Portable and wheeled halon, PKP, and CO₂ extinguishers must be discharged in an upright position. If the extinguisher is on its side or inverted, the siphon tube will not reach the agent and an unsatisfactory discharge will result.

6.5.3.1 Halon 1211 (Bromochlorodifluoromethane) Portable and Wheeled Unit Extinguishers

6.5.3.1.1 Definition. These extinguishers are intended primarily for use on Class B and C fires; however, Halon 1211 is effective on Class A fires. Halon 1211 is a colorless, faintly sweet smelling, electrically nonconductive gas which leaves no residue to clean up.

Halon 1211 extinguishes fires by inhibiting the chemical chain reaction of the combustion process. Halon 1211 is virtually noncorrosive, nonabrasive, and is at least twice as effective as CO₂ on Class B fires when compared on a weight of agent basis. Although the agent is retained under pressure in a liquid state and is self-expelling, a booster charge of nitrogen is added to ensure proper operation. Upon actuation, the vapor pressure causes the agent to expand so that the discharge stream consists of a mixture of liquid droplets and vapor. Halon 1211 extinguishers are marked with a reflective silver band around the tank.

WARNING

- Do not use Halon 1211 on Class D fires. It has no blanketing effect and, if it reaches a Class D fire in the liquid state, the possibility of an explosive reaction exists.
- The discharge of Halon 1211 to extinguish a fire creates a hazard to personnel (such as dizziness and impaired coordination) from the natural Halon 1211 product and from the products of decomposition that result through exposure of the agent to the fire. Exposure to the agent is of less concern than is the exposure to the products of decomposition. In using extinguishers of this type in unventilated spaces or confined areas, operators should use positive-pressure, self contained breathing apparatus.

6.5.3.1.2 Application. Initial application must start close to the fire. On all fires, the discharge should be directed at the base of the flames. Sweep the agent stream back and forth across the leading edge of the fire, overshooting on both sides, and continue to push the leading edge of the fire back until the fire is extinguished. These units have an effective discharge range of 10 to 30 feet, depending on ambient conditions, and a discharge time of 15 to 40 seconds, depending on the extinguisher size and application rate.

6.5.3.2 Carbon Dioxide (CO₂) 15-Pound Portable Units and 50-Pound Wheeled Extinguisher Units

6.5.3.2.1 Definition. These units are intended primarily for use on Class B and C fires. CO₂ is a colorless, odorless gas which is approximately one and one-half times heavier than air. It is stored in rechargeable containers designed to hold pressurized carbon dioxide in liquid form at atmospheric temperatures. Fire suppression is accomplished by the displacement of oxygen in the atmosphere to a level below the percent which is required to support combustion.

WARNING

- Exposure to CO₂ in high concentrations for extended periods of time can be fatal.
- The use of portable CO₂ extinguishers to inert flammable atmospheres is prohibited. When a portable CO₂ extinguisher is discharged, the liquid CO₂ expanding through the nozzle and cone becomes solid (commonly called "snow"). This "snow" contacting and separating from the extinguisher cone becomes electrically charged as does the extinguisher itself. If the charged "snow" contacts an insulated metal object, it will cause the object to become charged. Tests indicate that voltages greater than 15 kilovolts can be developed on insulated metal objects from a 1- to 2-second application of CO₂ from an extinguisher. This voltage is sufficient to cause a spark.

6.5.3.2.2 Application. Agent application should commence at the upwind edge and be directed slowly in a side-to-side sweeping motion, gradually moving toward the back of the fire. These extinguishers have a limited discharge range of 3 to 8 feet and a discharge time of 8 to 44 seconds, depending on the extinguisher size and application rate.

MIL-HDBK-844(AS)**6.5.3.3 Purple-K-Powder (PKP) Dry Chemical Powder Extinguishers**

6.5.3.3.1 Definition. These extinguishers are intended primarily for use on Class B fires. The principal base chemical used in the production of PKP dry chemical agent is potassium bicarbonate. Various additives are mixed with the base material to improve its stowage, flow, and water repellency characteristics. The ingredients used in PKP are nontoxic; however, the discharge of large quantities may cause temporary breathing difficulty, may seriously interfere with visibility, and may cause disorientation. Dry chemical agent does not produce a lasting inert atmosphere above the surface of flammable liquid; consequently, its use will not result in permanent extinguishment if reignition sources are present. These extinguishers are marked with a purple band around the tank

CAUTION

- Chemical agents may harden after being exposed to moisture. It is therefore important to avoid exposing them to any moisture during stowage, handling, and recharging evolutions.
- When PKP is used as the fire suppression agent on an aircraft fire and the agent is directed or ingested into an engine or accessory section, the fire chief, on-site personnel using the extinguisher, or senior fire official shall notify the maintenance officer of the unit involved or, in the case of a transient aircraft, the supporting facility. PKP injected into a jet engine cannot be completely removed without disassembly of the engine to remove deposits that penalize engine performance and restrict internal cooling air passages.

6.5.3.3.2 Application. These extinguishers have a discharge range of approximately 10 to 40 feet, depending on extinguisher size. Discharge time varies from 8 to 60 seconds. When used on flammable liquid fires, the stream should be directed at the base of the flame, gradually moving toward the

back of the fire while sweeping the nozzle rapidly from side to side.

Figure 6-2 lists the requirements for fire extinguishers around different types of operations. This figure has also been extracted from NAVAIR 00-80R-14 which is the controlling document and must be consulted for latest requirements.

6.6 HEALTH HAZARDS. Not only must aviation fuels be handled with caution because of the obvious dangers associated with possible fires and/or explosions, these materials also present a danger to the health of fuel handling personnel. These dangers are equally important as those of fires and explosions even though they are not so well known. In an attempt to comply with a recently enacted California law, Exxon Company U.S.A. has issued the following warning statement to inform people of the potential health hazards associated with all petroleum products including fuels

"Detectable amounts of 'chemicals known to the state of California to cause cancer, birth defects or other reproductive harm' may be found in petroleum products, intermediate products, by products, waste products and chemical products, and their vapors or result from their use. Read and follow label directions and other product safety and health information which you have been provided when handling or using these materials."

The following paragraphs discuss the principal health dangers from aviation fuels. Once these dangers are known and understood, they can be easily avoided by controlling or minimizing exposure of personnel to both the liquid and vapor forms of the fuels.

6.6.1 TOXIC VAPOR EFFECT. One of the greatest health hazards to fuel handling personnel is the toxic effect of the fuel vapors. Only a very small amount of fuel vapor in the air is sufficient to cause harmful effects. Since most fuel handling operations are usually conducted in the open, fuel vapors are sufficiently diluted by the ambient air so that there is no hazard to personnel. In the event of a fuel spill or a leak in an enclosed area, personnel must be very careful to avoid inhalation of the fuel vapors.

TYPE OF OPERATION	FIRE PROTECTION REQUIREMENT
Note	
All references to Halon 1211 extinguishers are for the 150-pound wheeled unit. Current in-service 150-pound PKP extinguishers are acceptable until Halon units can be placed in service.	
FLIGHT LINE PARKING AREA	
A. SMALL OR MEDIUM TYPE AIRCRAFT C-12, T-34, T-38, T-44, OV-10, A-3, A-4, A-6, A-7, AV-8, F-4, F-5, F-14, F/A-18, T-39, S-3, E-2, C-1, C-2, UH-1, AH-1, SH-2, H-3, H-57, H-46, H-60	1 Halon 1211 Extinguisher Per 3 Aircraft.
B. LARGE TYPE AIRCRAFT P-3, C-9, C-20, DC-10, C-130, C-131, C-141, KC-135, 707, 747, L-1011, KC-10, H-53	1 Halon 1211 Extinguisher Per 2 Aircraft.
Note	
<ul style="list-style-type: none"> • Two Halon 1211 extinguishers are required for each C-5 aircraft. • If any substitutions are required, the substituted unit should be approved by the fire department or CFR unit. As a general rule, any substitute portable extinguishing unit should have the same extinguishing capability as the Halon unit replaced. 	
C. HOT REFUELING – Transfer of fuel into aircraft tanks with one or more aircraft engines operating.	The minimum fire protection shall be two 150-pound Halon 1211 wheeled units positioned at each lane/island.
Note	
A crash fire vehicle (TAU) shall be on standby alert during multiple aircraft hot refueling operations. The location and response criteria will be determined by the Fire Chief/CFR Officer.	
D. CONCURRENT FUELING AND SERVICING OF AIRCRAFT WITHOUT PASSENGERS	1 Halon 1211 Extinguisher. Additionally, one major crash fire vehicle as specified in paragraph 5.2 shall be capable of responding to the scene within 3 minutes.
E. FUELING OF AIRCRAFT WITH PASSENGERS	1 Halon 1211 Extinguisher. Additionally, a TAU or major crash fire vehicle as specified in paragraph 5.2 shall be positioned at the aircraft.

N7/89

Figure 6-4. Airfield Fire Protection Requirements (Sheet 1 of 2)

MIL-HDBK-844(AS)

TYPE OF OPERATION	FIRE PROTECTION REQUIREMENT
Note	
Fire department/CFR unit shall be alerted at least 15 minutes prior to commencement of fueling operations. The number of passengers on board the aircraft shall be included in the notification	
F. FUELING OR SERVICING OF MEDICAL EVACUATION FLIGHTS WITH PASSENGERS/PATIENTS ONBOARD	1 150-pound Halon 1211 wheeled extinguisher. Additionally, one major CFR vehicle shall be positioned at the aircraft for optimum response. Turrets shall be manned and agent pumping equipment/systems ready for instant activation
Note	
Fire department/CFR unit shall be notified at least 15 minutes prior to commencement of concurrent servicing operations. The number of passengers/patients on board the aircraft shall be included in the notification	
G. HIGH POWER AND NEW ENGINE TURN-UP	2 Halon 1211 extinguishers located in immediate vicinity. One major CFR vehicle shall be capable of responding to the site within 3 minutes.
Note	
Fire department/CFR unit shall be notified at least 15 minutes prior to commencement of new engine turn-up	
H. COMBAT AIRCRAFT ORDNANCE LOADING AREA	1 Halon 1211 extinguisher Per 2 aircraft.
Note	
Fire department/CFR unit shall be notified of daily ordnance loading/unloading schedule.	

N12/85

Figure 6-4. Airfield Fire Protection Requirements (Sheet 2 of 2)

The first symptoms of the toxic effect of breathing fuel vapors are nausea, dizziness, and headaches. If any of these symptoms are noted while conducting fuel handling operations, personnel should immediately stop the operation and move to a fresh air location. If personnel are overcome by vapors, they should receive prompt medical attention. First aid procedures for personnel overcome by vapors include removal to fresh air, treatment for shock, and administering of artificial respiration if breathing has stopped.

6.6.2 LEAD POISONING. The tetraethyl lead which is added to all grades of aviation gasoline, is very poisonous. It is harmful if the vapors are inhaled or if the compound enters the body through the mouth by skin contact. The principal danger of lead poisoning occurs when it is necessary to enter or repair containers which have been used for leaded gasolines. Refueling and defueling personnel normally will not have to do such work, but it is important that they be aware of the danger, and that they know never to enter a tank or vessel which has contained leaded gasoline until the necessary safety precautions have been followed. The toxic effect of tetraethyl lead may also occur from prolonged exposure to gasoline vapors or liquids and, therefore, such exposure should be avoided. Another danger from leaded gasoline is from the fumes given off by stoves or lanterns burning a gasoline containing tetraethyl lead. For this reason, leaded gasoline shall never be used for such purposes.

6.6.3 INJURY TO SKIN AND EYES. Aviation gasoline and jet engine fuels may cause irritation if brought in contact with the skin. For this reason, direct skin contact with fuel should be avoided. If fuel is accidentally spilled on personnel, affected clothing should be removed immediately. Any skin areas exposed to fuel should be promptly washed with soap and water. If a person accidentally gets gasoline or jet fuel in the eyes, the fuel should be immediately removed by rinsing them with plenty of water. Medical attention must be administered as soon as possible.

6.6.4 SWALLOWING AVIATION FUELS. Swallowing even small amounts of aviation fuels is very harmful and medical attention should be obtained immediately.

6.6.5 FUEL TANK AND FILTER/SEPARATOR WATER BOTTOMS. The water that

collects in the bottom of fuel tanks and filter/separator often contains a high percentage (40 to 60%) of fuel system icing inhibitor (FSII). Since the FSII materials used in JP-5, DiEGME and especially JP-4, EGME are considered toxic in a pure or concentrated state, exposure of personnel to water bottoms of filter separators and tanks must be kept to the absolute minimum. If exposure occurs, wash with soap and water followed by a thorough fresh water rinse. Disposal of water bottoms must be accomplished in accordance with local environmental regulations.

6.6.6 SPECIFIC PROCEDURES FOR AVOIDING THE HEALTH HAZARDS OF AIRCRAFT FUELS. The NATOPS Aircraft Refueling Manual contains a list of procedures which will minimize the dangers to the health of fuel handling personnel.

MIL-HDBK-844(AS)

(This page intentionally left blank.)

APPENDIX A

VISUAL CONTAMINATION TABLE

MIL-HDBK-844(AS)

VISUAL CONTAMINATION TABLE

CONTAMINANT	APPEARANCE	CHARACTERISTICS	EFFECTS ON AIRCRAFT	ACCEPTABLE LIMITS
A. Water				
(1) Dissolved Water	Not Visible	Fresh water only Precipitates out as cloud when fuel is cooled	None unless precipitated out by cooling of fuel. Can then cause ice to form on low pressure fuel filter if fuel temperature is below freezing.	Any amount up to saturation
(2) Free Water	Light cloud. Heavy Cloud. Droplets adhering to sides of bottle. Gross amounts settled in bottom	Free water may be saline water or fresh water. Cloud usually indicates water-in-fuel emulsion.	Icing of fuel system - usually low pressure fuel filters. Erratic fuel gage readings. Gross amounts of water can cause flame-outs. Sea water will cause corrosion of fuel system components	Zero - fuel must contain no visually detectable free water.
B. Particulate Matter				
(1) Rust	Red or black powder, rouge, or grains. May appear as dye-like material in fuel.	Red rust (Fe_2O_3) - nonmagnetic Black rust (Fe_3O_4) - magnetic Rust generally comprises major constituent of particulate matter.	Will cause sticking and sluggish or general malfunction of fuel controls, flow dividers, pumps, nozzles, etc.	Fuel must contain less than 2 mg/liter.
(2) Sand or Dust	Crystalline, granular or glass-like	Usually present and occasionally constitutes major constituent	Will cause sticking, and sluggish or general malfunction of fuel controls, flow dividers, pumps, nozzles, etc.	Fuel must contain less than 2 mg/liter.
(3) Aluminum	White or grey powder or paste.	Sometimes very sticky or gelatinous when wet with water. Often present and occasionally represents major constituent	Will cause sticking, and sluggish or general malfunction of fuel controls, flow dividers, pumps, nozzles, etc.	Fuel must contain less than 2 mg/liter.

VISUAL CONTAMINATION TABLE (Cont'd)

CONTAMINANT	APPEARANCE	CHARACTERISTICS	EFFECTS ON AIRCRAFT	ACCEPTABLE LIMITS
C. Microbiological Growth	Brown, gray, or black. Stringy or fibrous.	Usually found with other contaminants in the fuel. Very light weight; floats or "swims" in fuel longer than water droplets or solid particles. Develops only when free water is present.	Fouls fuel quantity probes, sticks, flow dividers, makes fuel controls sluggish.	Zero.
D. Emulsions				
(1) Water-in-fuel Emulsions	Light cloud. Heavy cloud.	Finely divided drops of water in fuel. Same as free water could. Will settle to bottom in minutes, hours or weeks depending upon nature of emulsion.	Same as free water.	Zero - Fuel must contain no visually detectable free water.
(2) Fuel and water or "stabilized"	Reddish, brownish, grayish or blackish. Sticky material variously described as gelatinous, gummy or like catsup or mayonnaise.	Finely divided drops of fuel in water. Contains rust or microbiological growth which stabilizes or "firms" the emulsion. Will adhere to many materials normally in contact with the fuels. Usually present as "globules" or stringy, fibrous-like material in clear or cloudy fuel. Will stand from days to months without separating. This material contains half to three-fourths water, a small amount of fine rust or microbiological growth and is one-third to one-half fuel.	Same as free water and sediment, only more drastic. Will quickly cause filter plugging and erratic readings in fuel quantity probes.	Zero.
E. Miscellaneous				
(1) Interface Material	Lacy bubbles or scum at interface between fuel and water. Sometimes resembles jelly-fish.	Extremely complicated chemically. Occurs only when emulsion and free water is present.	Same as microbiological growth.	Zero - There should be no free water.
(2) Air Bubbles	Cloud in fuel.	Disperses upward within a few seconds.	None.	Any amount.

MIL-HDBK-844(AS)

(This page intentionally left blank).

APPENDIX B

PETROLEUM TESTING LABORATORIES

General. Aviation fuels require quality surveillance from the point of initial acceptance until they are actually used in the aircraft. Every activity and individual in the supply system that transports, stores, distributes, or issues these products is responsible for some phase of quality control. Two types of samples are required to ensure quality fuel for aircraft, these are **Special** and **Routine**. Definitions for each of these types of samples and procedures for field personnel to follow in submitting them are contained in the following paragraphs.

Special Samples. These are samples which are submitted for testing because the quality of the fuel is suspect either as a result of aircraft malfunctions or for other reasons.

Shipping Destinations: Special samples should be taken in duplicate and shipped to both the Naval Air Warfare Center, Aircraft Division, Trenton (NAWCADTRN) and to the nearest regional laboratory contained in the list which begins on the next page. NAWCADTRN is available to assist field personnel worldwide in the identification and resolution of quality problems and is responsible for determining the suitability of off-specification fuel for issuance to aircraft. NAWCADTRN's address and telephone numbers are listed in the table below.

Sample size: Each laboratory will require a minimum quantity of one gallon. This means two one gallon samples of fuel should be extracted from each problem location. Ship both samples by the fastest traceable means - the first gallon to NAWCADTRN and the second to the nearest regional laboratory.

Sample contains: Use the standard MIL-K-23714 specification red shipping containers.

Documentation: When a fuel quality problem is encountered the activity should contact NAWCADTRN via telephone immediately and follow up with a Naval message, telefax or letter which describes the problem and identifies a point of contact. *All samples should be properly labeled with all pertinent information (See paragraph 3.3.3 or 9.3.3 in the Aircraft Refueling NATOPS Manual, NAVAIR 00-80T-109).*

	Laboratory Shipping Address	Lab Mailing Address
	Naval Air Warfare Center Aircraft Division, Trenton Attn: Code PE33 1440 Parkway Avenue Trenton, NJ 08628-0176	Naval Air Warfare Center Aircraft Division, Trenton Attn: Code PE33 P.O. Box 7176 Trenton, NJ 08628-0176
Telephone Numbers:	DSN 442-7859 or commercial 609-538-6859 DSN 442-7929 or commercial 609-538-6929	
Telefax Numbers:	DSN 442-7562 or commercial 609-538-6562 DSN 442-7604 or commercial 609-538-6604	
Message Address:	NAVAIRWARCENACDIV TRENTON NJ//PE33// (Message must include Accounting Symbol and Program Designator Code (AS/PDC) NA-CRAFAA immediately after the list of addressees as discussed in paragraph 605 of the NTP 3 message instruction.)	

MIL-HDBK-844(AS)

Routine (monthly correlation) Samples. Routine Samples are the samples taken when no fuel problems or aircraft problems attributable to the fuel are known or suspected. These samples and their test results serve two purposes:

1. They assist the activity in monitoring the performance of their local fuel testing equipment and methods.
2. They provide TYCOM and SYSCOM cognizant offices with information on the general quality of the fuel delivered to aircraft and the performance of the fleet's quality control equipment.

The following laboratories are equipped to perform all tests required by aviation fuel specifications. Monthly correlation (routine) fuel samples should be shipped to the nearest or most convenient laboratory contained in the following list. Fuel quantities and sample locations are described in the Aircraft Refueling NATOPS Manual, NAVAIR 00-80T-109. *All samples should be properly labeled with all pertinent information (See paragraph 3.3.3 or 9.3.3 in the Aircraft Refueling NATOPS Manual, NAVAIR 00-80T-109).* Special samples (See paragraph on previous page) should be shipped to the closest laboratory annotated with an asterisk next to its location in the following list.

Location	Laboratory Shipping Address	Lab Mailing Address
<i>East Coast</i>		
* Norfolk, VA	Master Petroleum Laboratory Building W-388 Norfolk, VA 23512-5100	Director, Fuel Department Naval Supply Center Code 700 Norfolk, VA 23512-0700
Jacksonville, FL	Director, Fuel Department Navy Supply Center Code 700 8808 Somers Road Jacksonville, FL 32218-2600	(Same as Shipping Address)
* Searsport, ME	Director, Aerospace Fuels Laboratory Det 20, SA-ALC/SFTLB Trundy Rd, Bld 14 Searsport, ME 04974-0408	Det 20, SA-ALC/SFTLB P O. Box 408 Searsport, ME 04974-0408
* Dayton, OH	Director, Aerospace Fuels Laboratory Det 13, SA-ALC/SFTLA Area B Bldg 70 Wright-Patterson AFB OH 45433-6503	Det 13, SA-ALC/SFTLA Wright-Patterson Air Force Base Dayton, OH 45433-6503
* Tampa, FL	Director, Aerospace Fuels Laboratory Det 21, SA-ALC/SFTLC Bldg 1121 MacDill Air Force Base, FL 33608-0051	Det 21, SA-ALC/SFTLC P.O. Box 6051 MacDill AFB, FL 33608-0051

Location	Laboratory Shipping Address	Lab Mailing Address
<i>West Coast</i>		
* San Diego, CA	Fleet and Industrial Supply Center Point Loma Subbase Bldg. 50 199 Rosecranes San Diego, CA 92106	Director, Fuel Department Naval Supply Center Code 700 937 North Harbor Dr. San Diego, CA 92132
Seattle, WA	Naval Supply Center 7501 Beach Drive Port Orchard, WA 98366	Director, Fuel Department Naval Supply Center Code 700 P.O. Box 8 Manchester, WA 98353-0008
* Mukilteo, WA	Director, Aerospace Fuels Laboratory Det 35, SA-ALC/SFTLD Ten Park Avenue C, Bldg 1 Mukilteo, WA 98275-0046	Det 35, SA-ALC/SFTLD Ten Park Avenue C, Bldg 1 Mukilteo, WA 98275-0046
<i>Pacific</i>		
* Pearl Harbor, HI	Director, Fuel Department Naval Supply Center Code 700 Pearl Harbor, HI 96860	Director, Fuel Department Naval Supply Center Code 700 Box 300 Pearl Harbor, HI 96860-5300
<i>NOTE: NSC Pearl Harbor facilities should be used by units in the Central Pacific.</i>		
Guam, Marianas Island	Director, Fuel Department U.S. Naval Supply Depot Code 700 PSC 455 Box 190 FPO AP 96540-1500	(Same as Shipping Address)
Yokosuka, Japan	U.S. Navy Fuel Depot Yokosuka, Detachment Sasebo PSC 476 Box 7 FPO AP 96322-1504	(Same as Shipping Address)

MIL-HDBK-844(AS)

Location	Laboratory Shipping Address	Lab Mailing Address
<i>North Atlantic</i>		
* Keflavik, Iceland	Fuels Officer NAS Keflavik, IC Box 32 PSC 1003 FPO AE 09728-0332	Commanding Officer U.S. Naval Air Station Code 403 Box 32 PSC 1003 FPO AE 09728-0332PSC 1003
* Suffolk, England UK	Director, Aerospace Fuels Laboratory OL SA-ALC/SFTLF Bldg 725 RAF Mildenhall APO AE 09459	(Same as Shipping Address)
<i>Mediterranean and Middle East</i>		
* Venice, Italy	Director, Aerospace Fuels Laboratory OL SA-ALC/SFTLJ Bldg. 505 Aviano Airbase APO AE 09601	(Same as Shipping Address)
<i>Indian Ocean</i>		
* Diego Garcia	Commanding Officer U.S. Naval Support Facility Code 407 Box 4 FPO AA 96464-0004	(Same as Shipping Address)

Note: Additions, corrections or changes to the above list should be forwarded to:

Naval Air Systems Command
AIR-5363C
Washington, DC 20361-5360

APPENDIX C

**AIRCRAFT INFORMATION
SUMMARIES**

The following section provides general information about Navy and Marine Corps aircraft configurations, characteristics and requirements which can impact aircraft refueling operations. It is assembled here for use by fuel handling personnel in general planning and other purposes. The information has been extracted from individual aircraft NATOPS Aircraft Manuals which must be consulted for the most accurate, up-to-date information.

<u>Aircraft</u>	<u>Page Number</u>
A-6	C-2
AV-8B	C-7
E-2/C-2	C-12
F-14	C-16
F-18	C-20
S-3	C-25
P-3	C-29
H-1	C-33
H-2	C-37
H-3	C-41
H-46	C-45
H-53	C-49
SH-60	C-54

MIL-HDBK-844(AS)

AIRCRAFT: A-6 AIRCRAFT CONFIGURATION

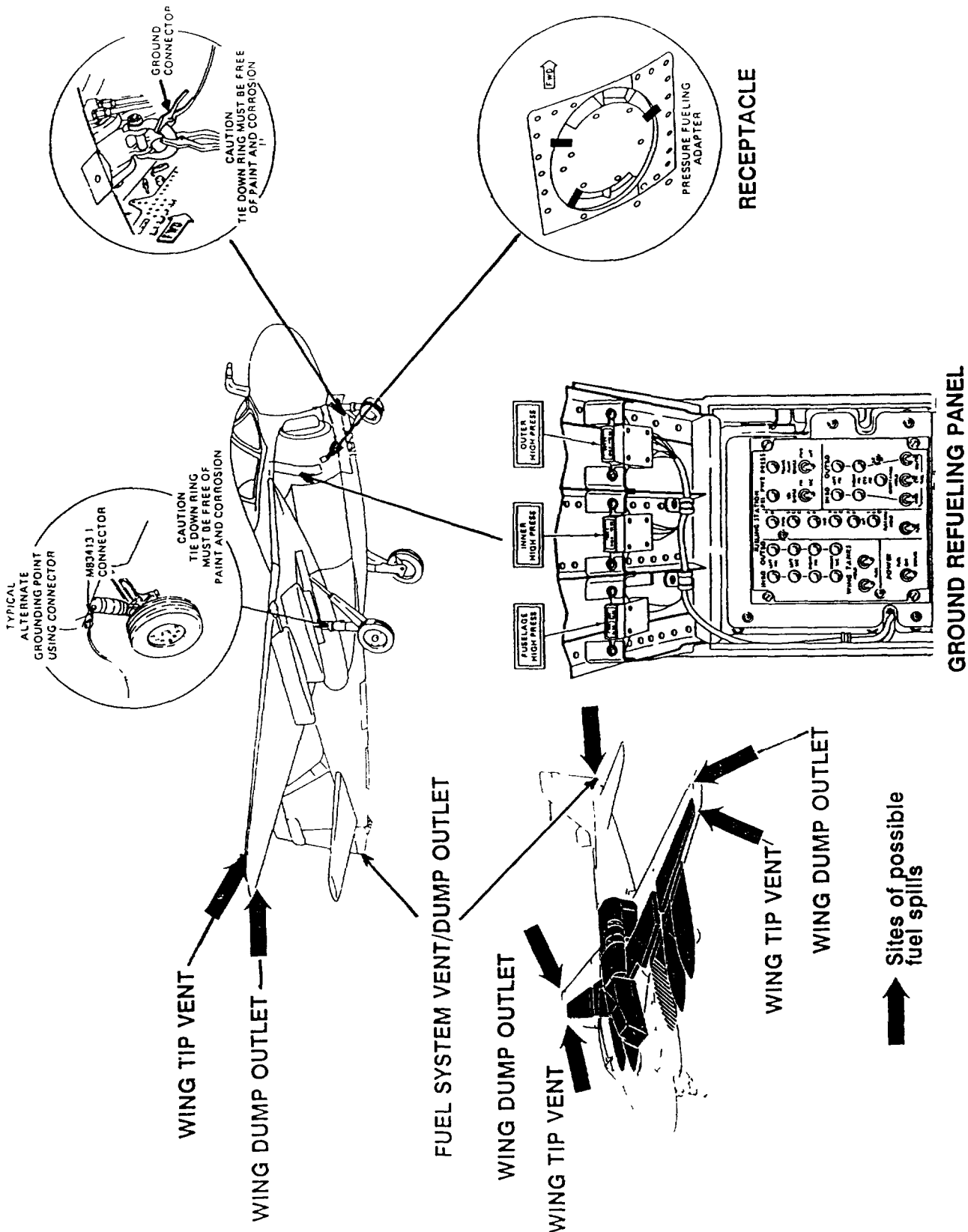

AIRCRAFT: A-6

TABLE OF FUEL CAPACITIES

Tank		Gallons
Internal	Fuselage	1,344
	Wing	1,028
	Total Internal	2,372
External	Drop Tank (Each)*	300
		400
	Air Refueling Store	300

* Two sizes of tanks are available

AIRCRAFT CHARACTERISTICS

Aircraft Dimensions		Aircraft Weight
Wing Span		Maximum Gross Weight 74,350 lbs
Spread	53 ft	
Folded	25 ft 4 in	
Length	54 ft 9 in	Maximum Footprint 230 psi
Height	16 ft 2 in	

A-6 REFUELING PROCEDURES

The following procedures cover only the refueling procedures which are unique to the A-6 aircraft, primarily the operation of the "pre-check" system. In addition to these specialized procedures, the applicable, basic refueling procedures contained in chapter 6 or 12 of the Aircraft Refueling NATOPS Manual, NAVAIR 00-80T-109, must be followed.

WARNING

A-6 aircraft are normally hot refueled with both engines operating. **DO NOT ASSUME RIGHT ENGINE TURNED OFF** until confirmation obtained.

1. Set "POWER" switch on ground refueling panel to "FUEL", and set "WING TANKS", "FUS TANKS",

and "DROP TANKS" switches to "FUEL".

2. On ground refueling panel access door, press "OUTER HIGH PRESS" indicator. All three "High Pressure" indicator lights on the door should light.

3. On ground refueling panel, momentarily press each "WING TANKS", "FUS TANKS", and "DROP TANKS" indicator that is not lighted; each indicator shall light.

CAUTION

If indicators checked in steps 2 and 3 malfunction, do not fuel aircraft.

4. Attach refueling nozzle to aircraft receptacle and

MIL-HDBK-844(AS)

AIRCRAFT: A-6

place nozzle flow control handle in the open position.

5 Initiate fuel flow and monitor tank "High Pressure" lights on door above ground refueling panel.

CAUTION

Immediately stop fuel flow if any of the three "High Pressure" indicators light during the refueling operation. Cause of vent system overpressure must be corrected before fueling is resumed

6. Exercise pre-check system Set and hold "SOL CHECK" switch to "PRI". All "WING TANKS PRI", "FUS TANKS PRI", and "DROP TANKS PRI" indicator lights shall go out and fuel flow into the aircraft stop prior to aircraft receiving 45 gallons of fuel

7. When fuel flow stops, check flow rate. If flow rate exceeds 3 gallons per minute, discontinue hot refueling operation.

8. On ground refueling panel, set "DROP TANKS" switches to "HOLD" and release "SOL CHECK" switch.

9 When fuel flow starts, immediately set and hold "SOL CHECK" switch to "SEC" All "WING TANKS SEC", and FUS TANKS SEC" indicator lights shall go out and fuel flow automatically stop prior to aircraft receiving 30 gallons of fuel

10. When fueling stops, check fuel flow rate. If flow rate exceeds 3 gallons or 20 pounds per minute, shut off fueling unit and disconnect fuel nozzle.

11. On ground refueling panel, set "WING TANKS" switches to "HOLD" and release "SOL CHECK" switch.

12. Fuel fuselage tanks until "FUS TANK" indicators on ground refueling panel go out.

13. On ground refueling panel, set "WING TANKS" switches to "FUEL"; on aircraft with external tanks, set "DROP TANKS" switches to "FUEL" When "WING TANKS", "FUS TANK", and "DROP TANKS" indicators are all out, aircraft is fueled.

14. Set "POWER" switch to "OFF" on ground refueling panel.

SPECIAL NOTES
AIRCRAFT FUEL SYSTEM

1. Under normal conditions, all air being displaced by fuel in the tanks, including external tanks, exits the aircraft through the common "Fuel System Vent/Dump Outlet".

2. If any high level shut-off valves fail to operate correctly, fuel may spill from the "Fuel System Vent/Dump Outlet" or the "Wing Tip Vents".

3. A malfunction within an external fuel tank may cause fuel to spill from the bottom center of tank (pressure relief vent)

AIRCRAFT: A-6

GROUND REFUELING PANEL

TANK HIGH PRESSURE LIGHTS

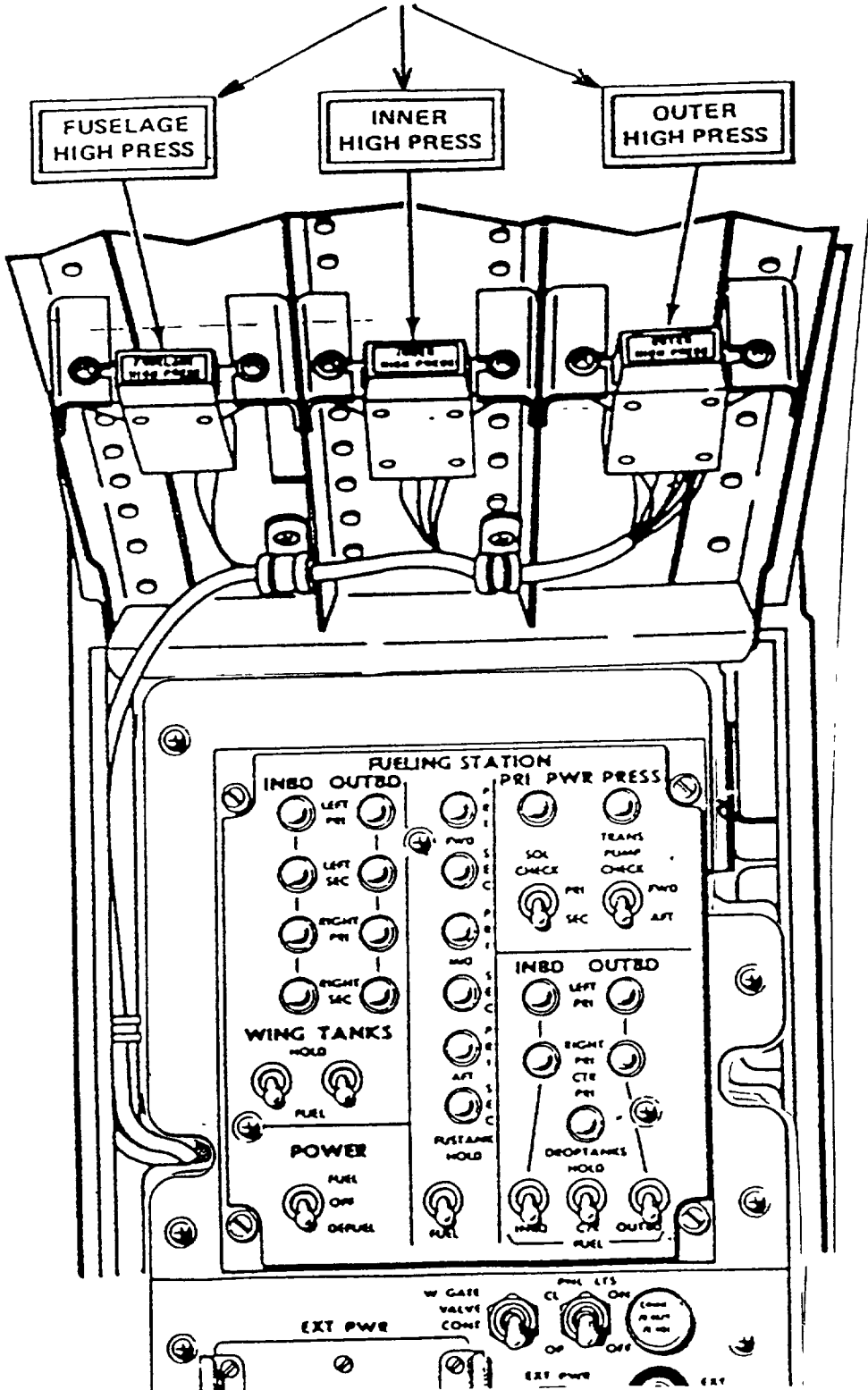

AIRCRAFT: A-6

PERSONNEL DANGER ZONES

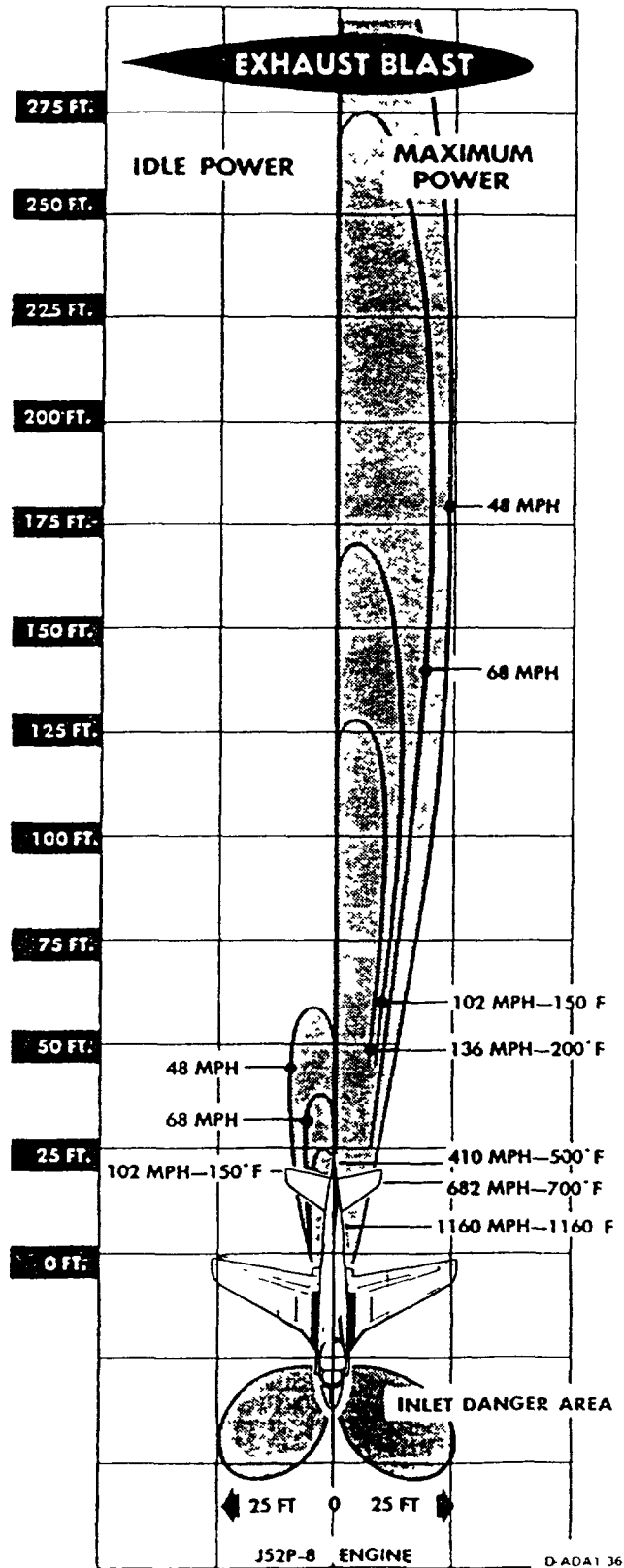

AIRCRAFT: AV-8B

AIRCRAFT CONFIGURATION

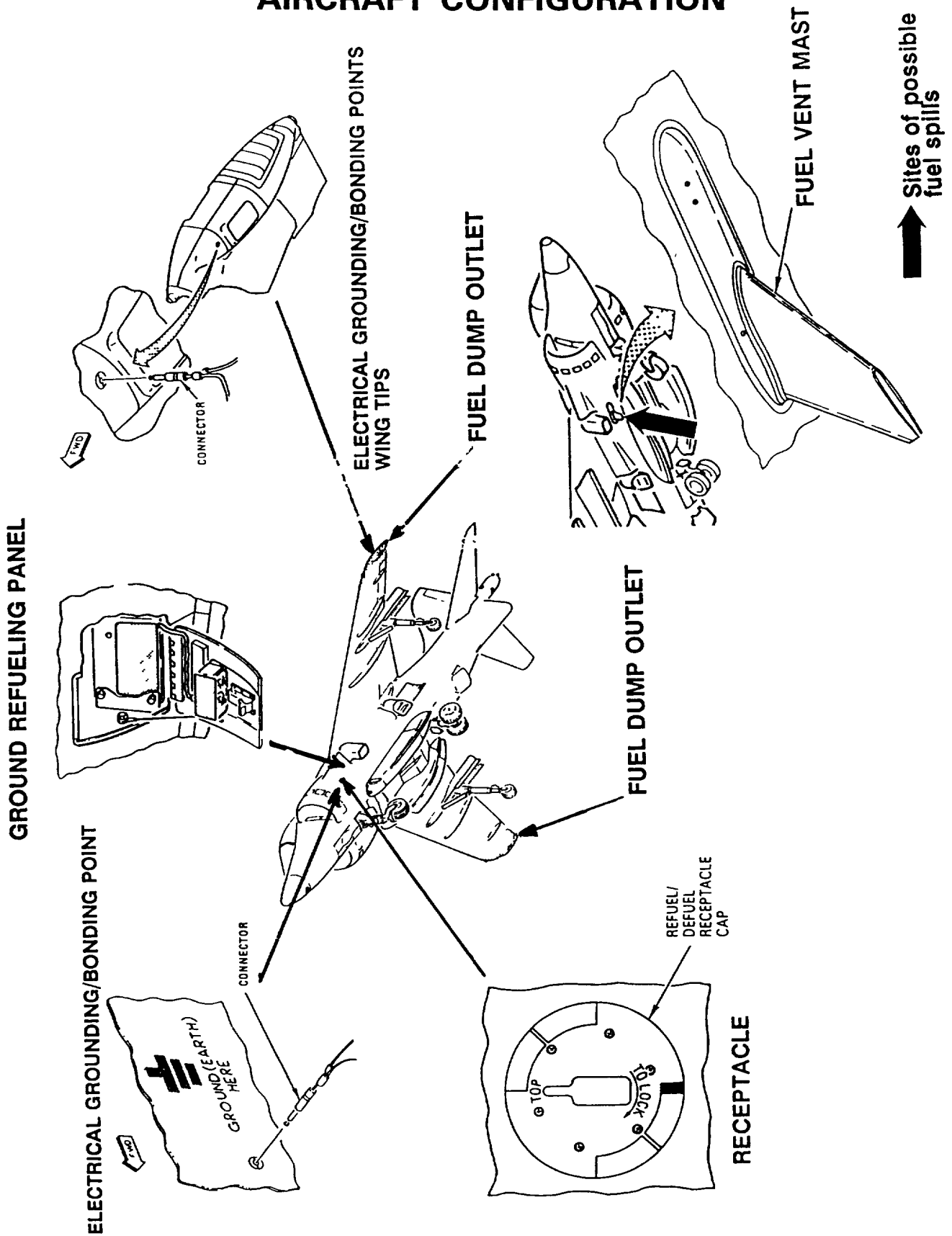

MIL-HDBK-844(AS)

AIRCRAFT: AV-8B**TABLE OF FUEL CAPACITIES**

Tank		Gallons	
Internal	Fuselage	Left Tank	47
		Left Front	80
		Right Front	80
		Right Center	47
		Rear	162
	Wing	Left	362
		Right	362
Total Internal		1,140	
External Tanks (Each)		300	
Totals	With 2 External Tanks	1,720	
	With 4 External Tanks	2,328	

AIRCRAFT CHARACTERISTICS

Aircraft Dimensions		Aircraft Weight
Wing Span Spread	30 ft 4 in	Maximum Gross Weight 21,500 lbs
Length	46 ft 4 in	Maximum Footprint 115 psi
Height	11 ft 9 in	

AV-8B REFUELING PROCEDURES

The following procedures cover only the refueling procedures which are unique to the AV-8B aircraft, primarily the operation of the "pre-check" system. In addition to these specialized procedures, the applicable, basic refueling procedures contained in chapter 6 or 12 of the Aircraft Refueling NATOPS Manual, NAVAIR 00-80T-109, must be followed.

1 Remove receptacle cap and attach refueling nozzle

2. Open door 22.

3. Press-to-test "TANK OVER PRESS" warning light on ground refueling panel for lamp operation.

4. Set "LEFT" and "RIGHT REFUEL" switches on the ground refueling panel (door 22) to the "REFUEL" position (toggles down) and start refueling.

5. Make sure "LEFT" and "RIGHT FUEL

AIRCRAFT: AV-8B

CONTENTS" lights are on.

CAUTION

- If any of the three lamps fails to operate in steps 3 and 5 above, discontinue refueling operation immediately. System failure must be investigated and resolved before hot refueling can be accomplished.

6 Fuel can be stopped from entering the external tanks by setting "EXT TANK LOCKOUT" switch to "LOCKOUT" position

7. Monitor the "TANK OVER PRESS" warning light

CAUTION

- Immediately stop fuel flow if "TANK OVER PRESS" indicator lights. "Hot refueling" can not be performed on the aircraft until problem is resolved.

8. After 60 to 120 gallons of fuel have entered the aircraft's tanks, make sure air is venting from FUEL VENT MAST.

9. Watch the "LEFT" and "RIGHT FUEL CONTENTS" lights. When the lights go off, the aircraft is full. Immediately stop fuel flow and close and lock the nozzle's flow control handle.

10. Set "LEFT" and "RIGHT REFUEL" switches to flight position (toggles up).

Note: If any of the high level shut off valves fail to operate correctly, fuel will spill from the vent mast. Turn off fuel flow immediately!

SPECIAL NOTES AIRCRAFT FUEL SYSTEM

- 1 This aircraft is NOT equipped with a pre-check system.
2. Under normal conditions, all air being displaced by fuel in the tanks, including external tanks, exits the aircraft through the common "Fuel Vent Mast".
3. If any high level shut-off valves fail to operate correctly, fuel may spill from the "Fuel Vent Mast".
4. A malfunction within an external fuel tank may cause fuel to spill from the bottom center of tank (pressure relief vent).

MIL-HDBK-844(AS)

AIRCRAFT: AV-8B

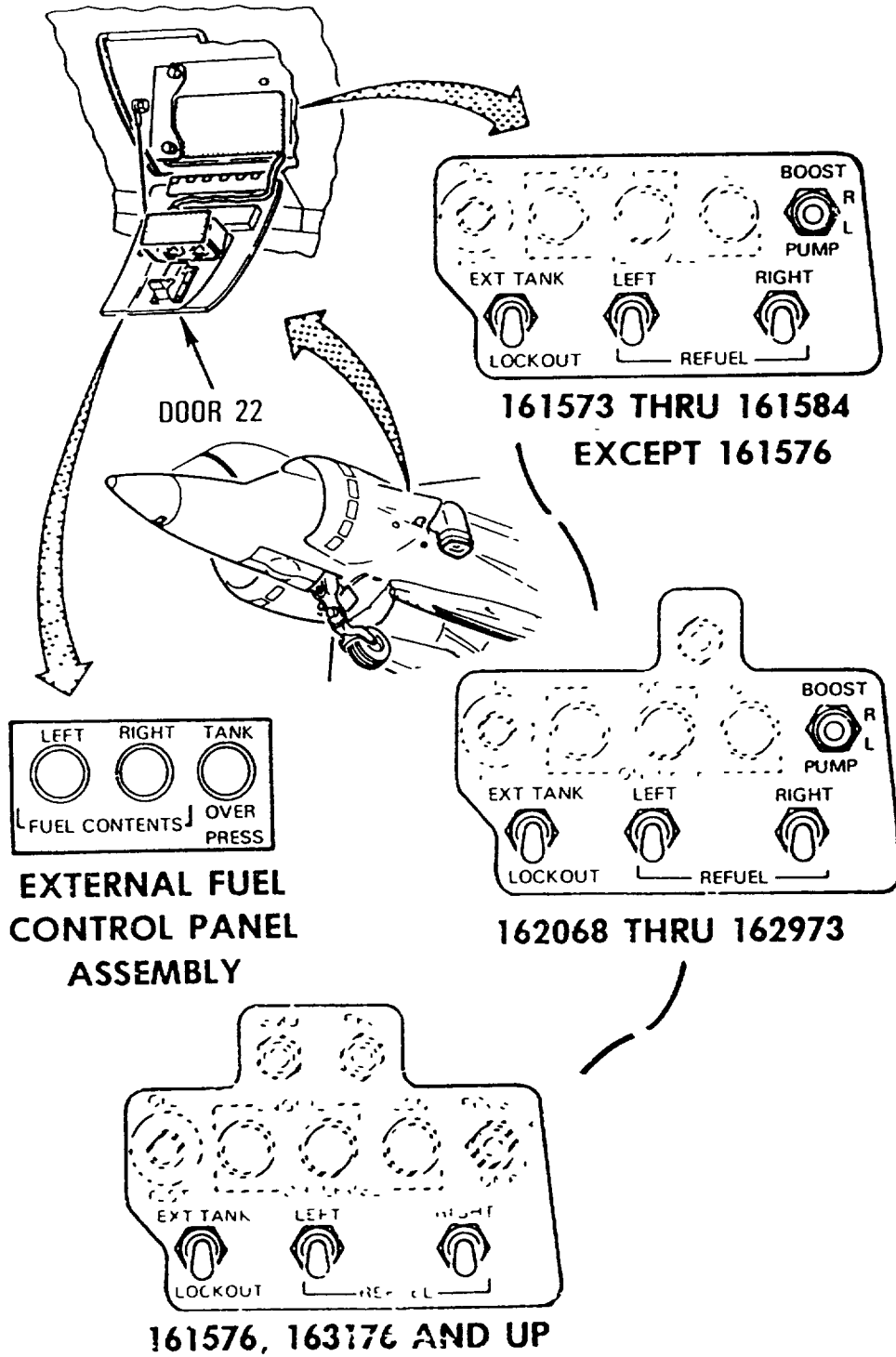

GROUND REFUELING PANEL



AIRCRAFT: AV-8B

PERSONNEL DANGER ZONES

LEGEND

-  DANGER AREA
-  AVOID AREA TO PREVENT FOREIGN OBJECT DAMAGE (FOD)

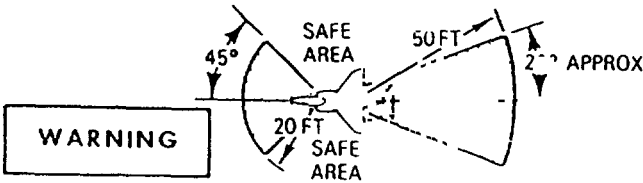

Areas immediately aft and adjacent to thrust nozzles and forward and adjacent to engine intakes must be avoided

IDLE POWER NOZZLES FULL AFT TO 10° DOWN

Safe area is safe for maintenance when engine is idling and nozzles are aft (0° to 10° nozzle deflection)

Personnel should avoid being out of the pilot's view during vertical take-off vertical landing or hovering unless they are by a fixed obstruction known to the pilot

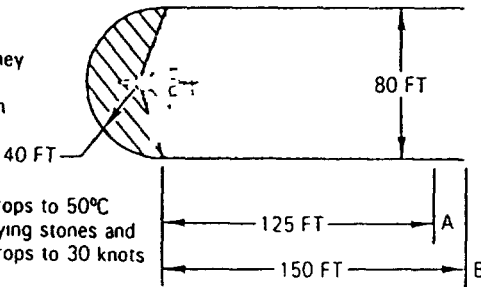

- A Temperature drops to 50°C
- B Danger from flying stones and earth Speed drops to 30 knots

THROTTLE SET ABOVE IDLE NOZZLES FROM FULL AFT TO 45°

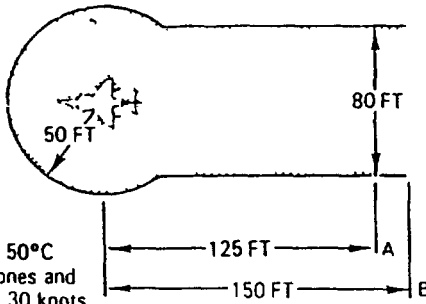

- A Temperature drops to 50°C
- B Danger from flying stones and earth Speed drops to 30 knots

THROTTLE SET ABOVE IDLE NOZZLES FROM 45° TO FULL DOWN

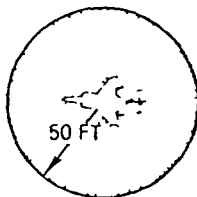

THROTTLE SET ABOVE IDLE NOZZLES DOWN

MIL-HDBK-844(AS)

AIRCRAFT: E-2 / C-2

AIRCRAFT CONFIGURATION

TANK PRESS RELIEF VALVES

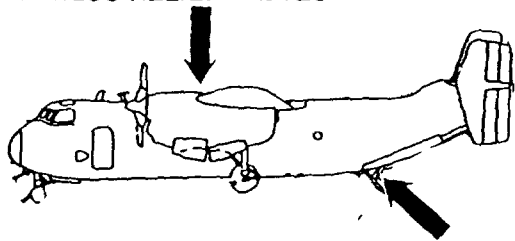

FUEL SYSTEM VENT/
DUMP PORT (C-2)

TANK PRESSURE
RELIEF VALVES

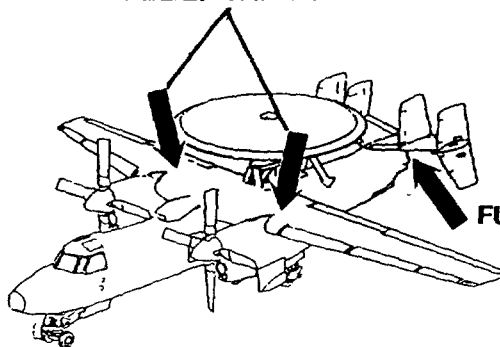

FUEL SYSTEM VENT/
DUMP PORT (E-2)

→ Sites of possible
fuel spills

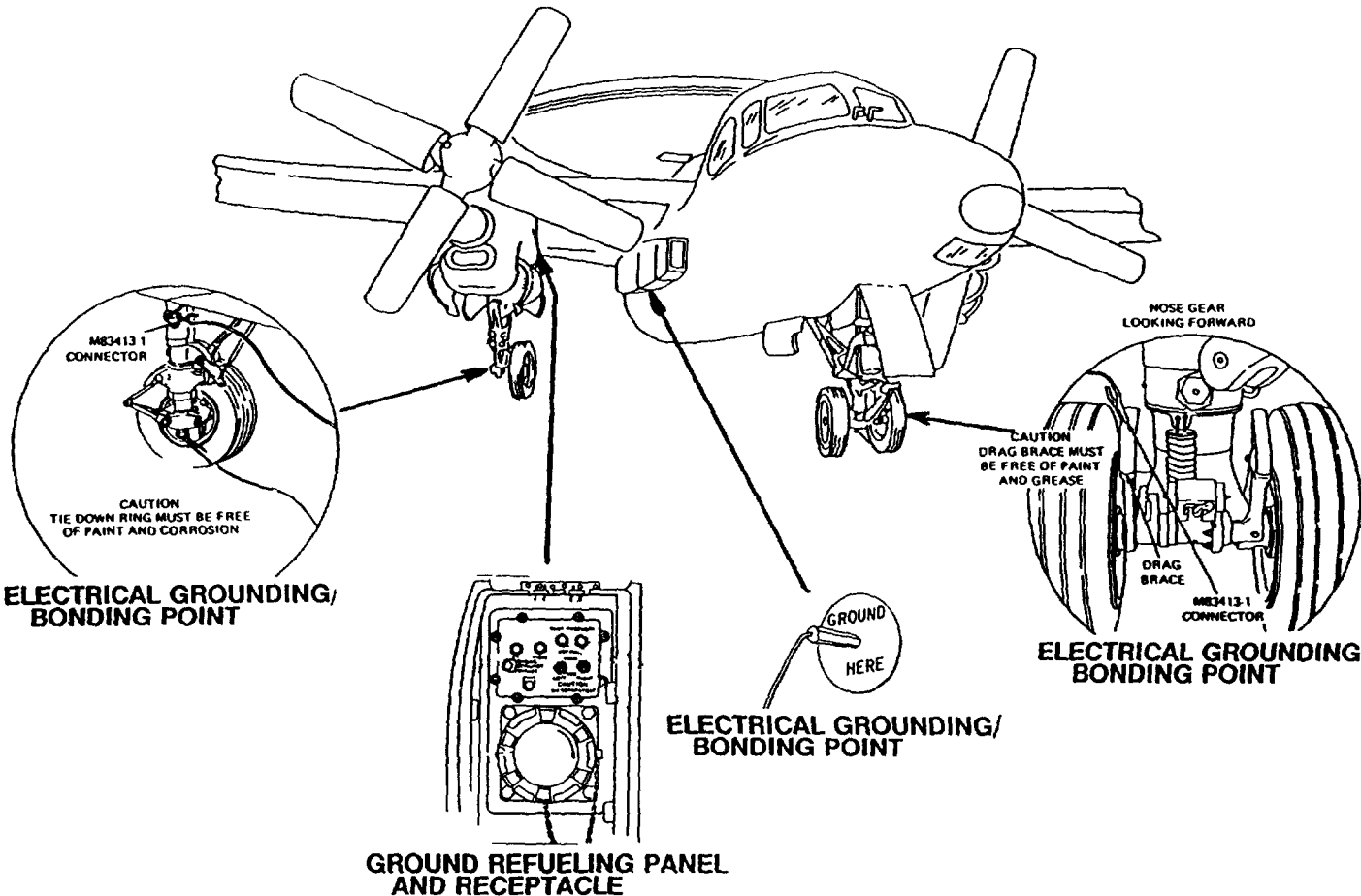

AIRCRAFT: E-2 / C-2

TABLE OF FUEL CAPACITIES

Tank		Gallons
Wings	Left	912
	Right	912
Total Internal		1,824

AIRCRAFT CHARACTERISTICS

Aircraft Dimensions		Aircraft Weight
Wing Span		Maximum Gross Weight 53,000 lbs
Spread	80 ft 7 in	
Folded	29 ft 4 in	
Length	57 ft 7 in	Maximum Footprint 260 psi
Height	18 ft 4 in	

E-2 / C-2 REFUELING PROCEDURES

The following procedures cover only the refueling procedures which are unique to the E-2 / C-2 aircraft, primarily the operation of the "pre-check" system. In addition to these specialized procedures, the applicable, basic refueling procedures contained in chapter 6 or 12 of the Aircraft Refueling NATOPS Manual, NAVAIR 00-80T-109, must be followed.

WARNING

E-2 aircraft are normally hot refueled with both engines operating. **DO NOT ASSUME RIGHT ENGINE TURNED OFF** until confirmation obtained.

1. Open "PRESS FUEL STA" access door.
2. Remove receptacle cap, attach refueling nozzle, open nozzle to the fully open and locked position and initiate fuel flow. "NOT FULL" lights on pressure fueling station should illuminate.

CAUTION

- Discontinue Hot Refueling operation immediately if "NOT FULL" lights fail to illuminate.
 - Ensure that vent at tail of aircraft is clear and that tanks are venting during fueling. If no venting is indicated, cease fueling operation immediately.
3. Hold left "TANK PRECHECK" switch to "PRIM". After the left "NOT FULL" light goes off (approximately 3 seconds later) hold the right "TANK PRECHECK" switch to "SEC". After the right "NOT FULL" light goes off fuel flow into the aircraft should stop.
 4. Release switches and fuel flow should resume.
 5. Repeat the precheck process in step three above, this time holding the left "TANK PRECHECK"

MIL-HDBK-844(AS)

AIRCRAFT: E-2 / C-2

switch to "SEC" and the right "TANK PRECHECK"
switch to "PRIM".

WARNING**CAUTION**

- Aircraft should not be completely filled during hot refueling operations since failure of a high level shut-off valve will result in fuel flowing out of the pressure relief valve and onto a engine exhaust pipe

SPECIAL NOTES
AIRCRAFT FUEL SYSTEM

- If fuel flow does not stop when "NOT FULL" lights go off in either step 3 or 5 above, discontinue hot refueling operation immediately. System failure must be investigated and resolved before hot refueling can be accomplished.
6. Release switches and refuel aircraft until pilot gives hand signal indicating aircraft is full or he wishes refueling terminated

1. Under normal conditions, all air being displaced by fuel in the tanks exits the aircraft through the common "Fuel System Vent/Dump Port" (in the tail on the E-2 and on the fuselage on the C-2)

2. If any high level shut-off valves fail to operate correctly, fuel may spill from special pressure relief valves on the tops of the wings.

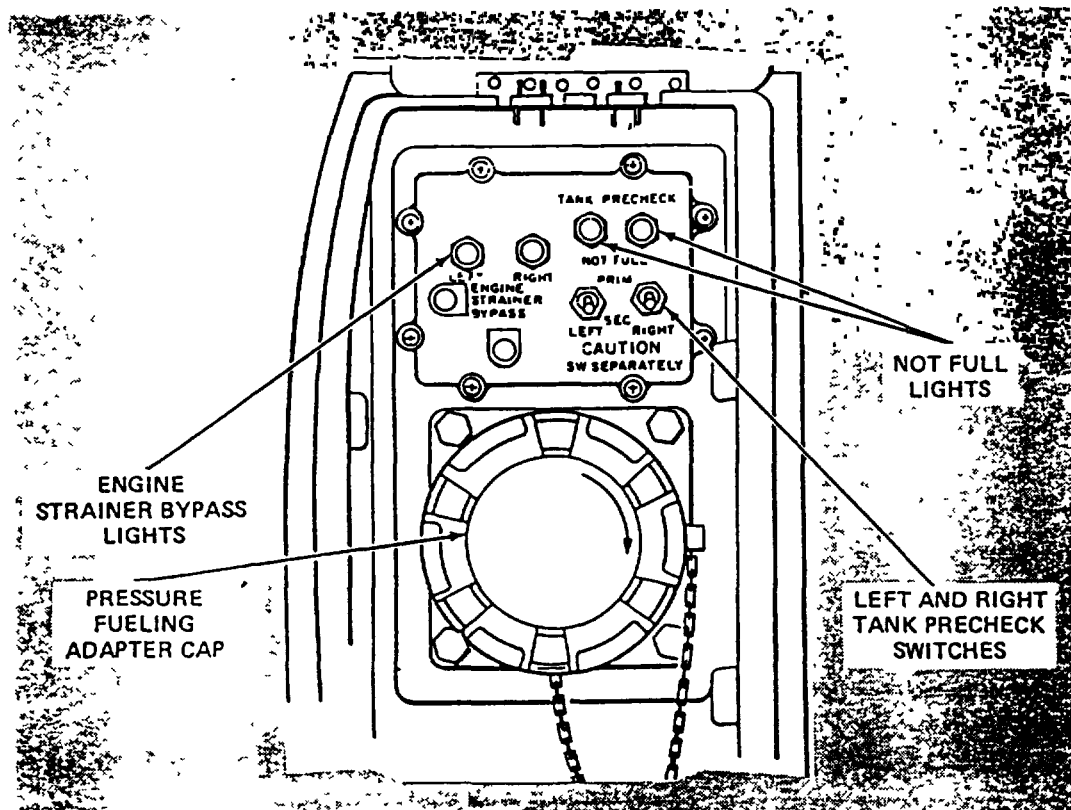
GROUND REFUELING PANEL

AIRCRAFT: E-2 / C-2

PERSONNEL DANGER ZONES

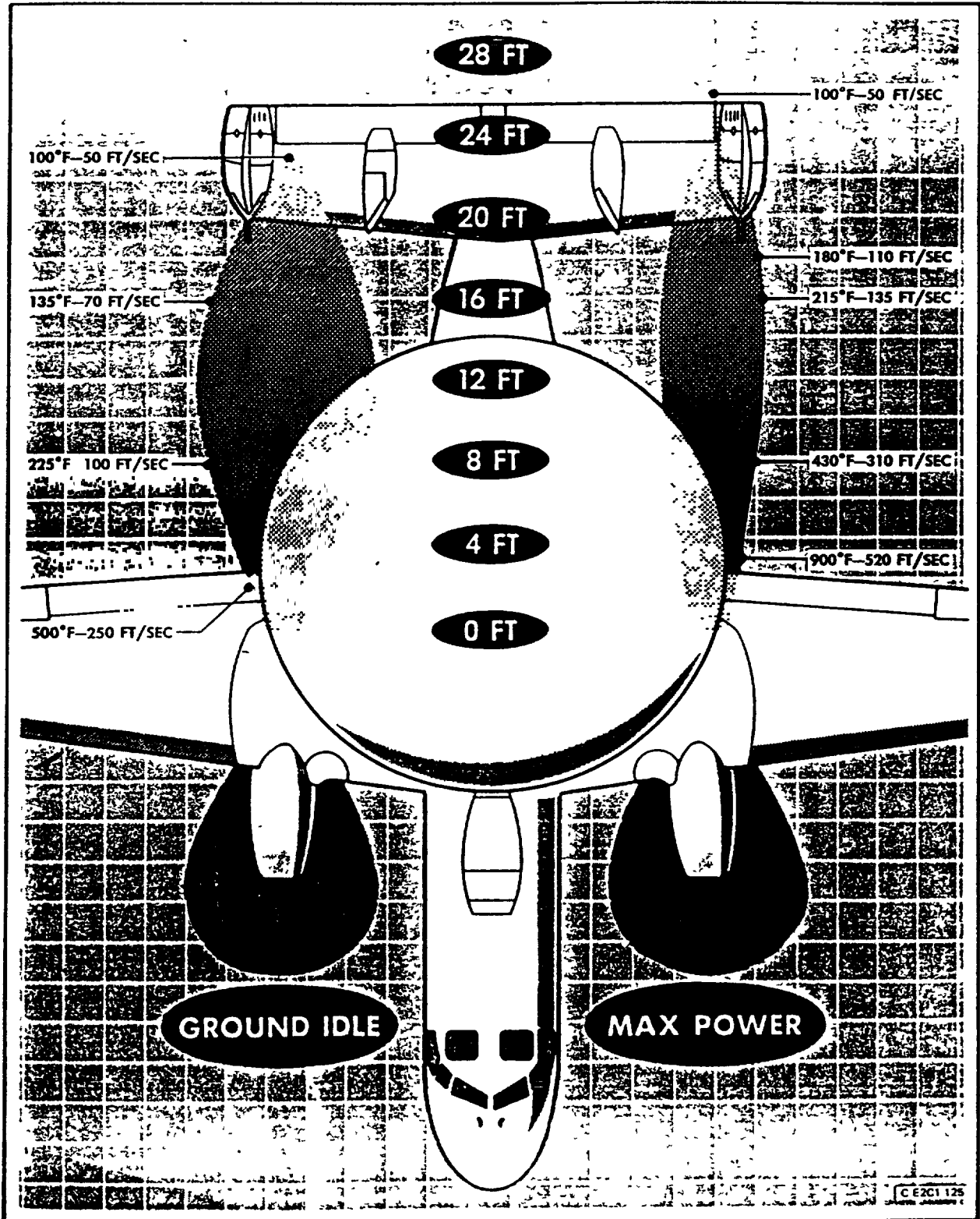

MIL-HDBK-844(AS)

AIRCRAFT: F-14

AIRCRAFT CONFIGURATION

GROUND REFUELING PANEL AND RECEPTACLE

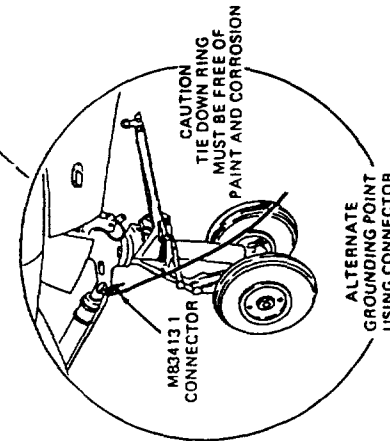
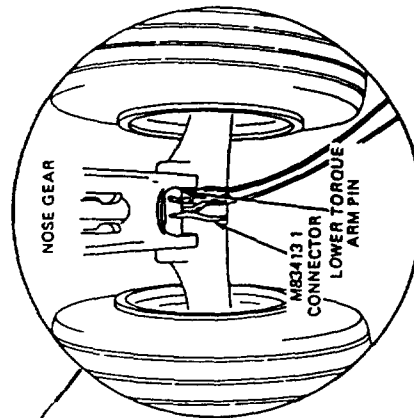
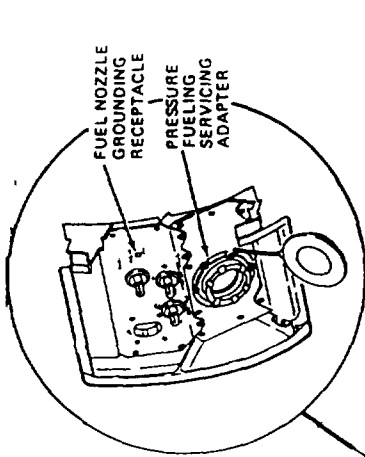

ELECTRICAL GROUNDING/BONDING POINTS

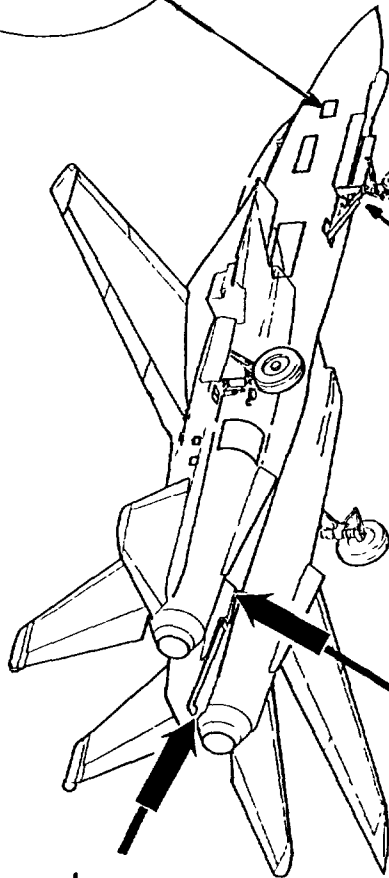

DUMP MAST

FUEL SYSTEM VENT

Sites of possible fuel spills



AIRCRAFT: F-14

TABLE OF FUEL CAPACITIES

Tank			Gallons
Internal	Fuselage	Forward	691
		Aft	648
		Right Feed	235
		Left Feed	221
	Wing	Left	295
		Right	295
Total Internal			2,385
Total External			534
Total Capacity			2,919

AIRCRAFT CHARACTERISTICS

Aircraft Dimensions		Aircraft Weight
Wing Span		Maximum Gross Weight 74,349 lbs
Spread	64 ft 1½ in	
	Folded	38 ft 2½ in
Length	62 ft 8½ in	Maximum Footprint 314.5 psi
Height	16 ft 1½ in	

F-14 REFUELING PROCEDURES

The following procedures cover only the refueling procedures which are unique to the F-14 aircraft, primarily the operation of the "pre-check" system. In addition to these specialized procedures, the applicable, basic refueling procedures contained in chapter 6 or 12 of the Aircraft Refueling NATOPS Manual, NAVAIR 00-80T-109, must be followed.

1. Attach refueling nozzle to aircraft and place nozzle flow control handle in the open position.
2. Initiate fuel flow and observe vent pressure gage on ground refueling panel.

CAUTION

- Immediately stop fuel flow if indicator moves to "STOP FUEL" or red position.
3. Exercise pre-check system by switching both the "FUSE TANKS" and "WING EXT TANKS" handles to the "STOP FUEL" position. Fuel flow into the aircraft should stop within a few seconds.

MIL-HDBK-844(AS)

AIRCRAFT: F-14**CAUTION**

- If fuel flow does not stop, discontinue refueling operation immediately. System failure must be investigated and resolved before hot refueling can be accomplished.
- 4 Return pre-check handles to the "FUEL" position and continue fueling until aircraft tanks are filled and fuel flow automatically stops.

**SPECIAL NOTES
AIRCRAFT FUEL SYSTEM**

1. Under normal conditions, all air being displaced by fuel in the tanks, including external tanks, exits the aircraft through the common "Fuel System Vent".
2. If any high level shut-off valves fail to operate correctly, fuel may spill from the "Fuel System Vent".
3. A malfunction within the external fuel tanks may cause fuel to spill from the bottom center of the external tank (pressure relief vent).

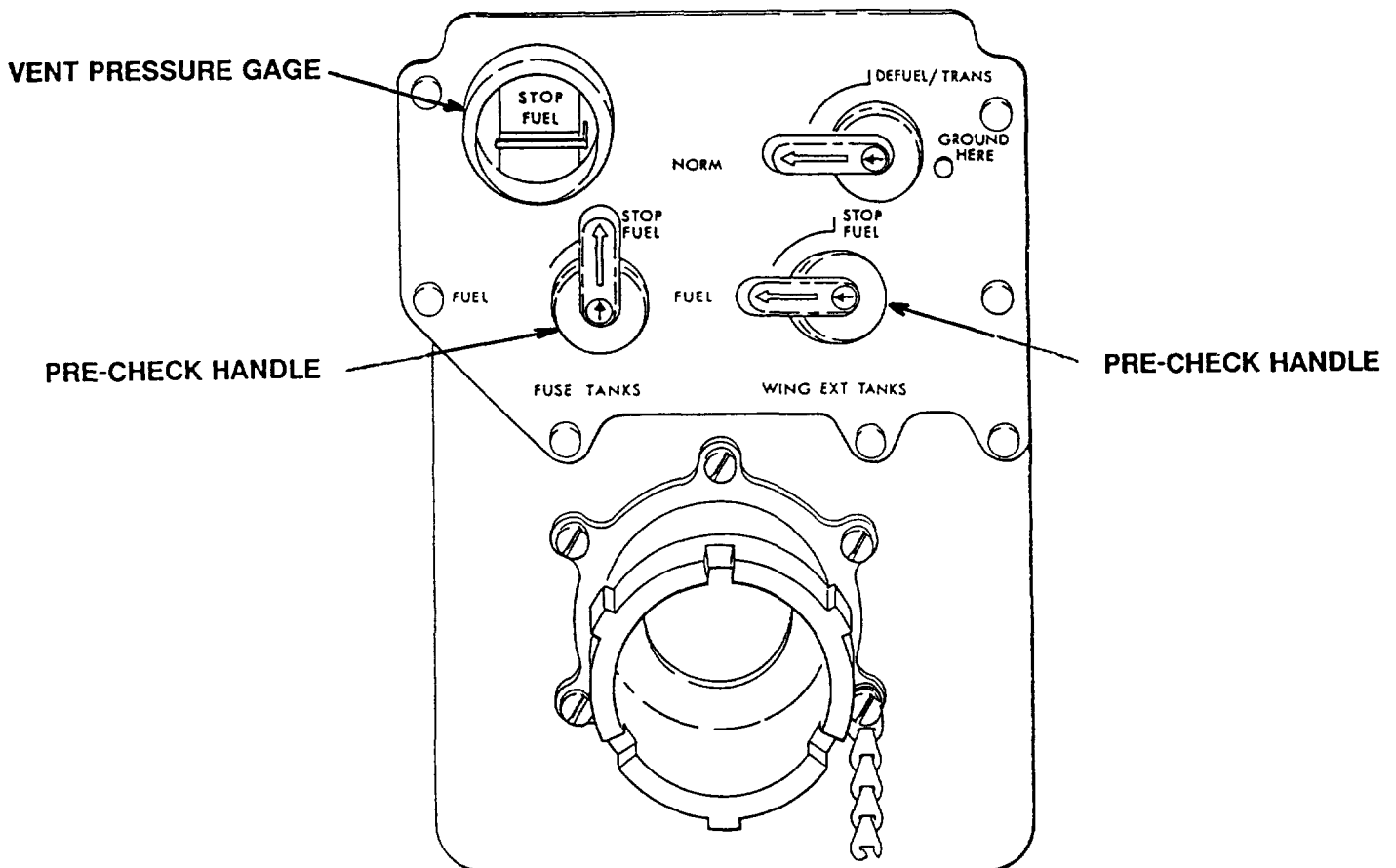
GROUND REFUELING PANEL

AIRCRAFT: F-14

PERSONNEL DANGER ZONES

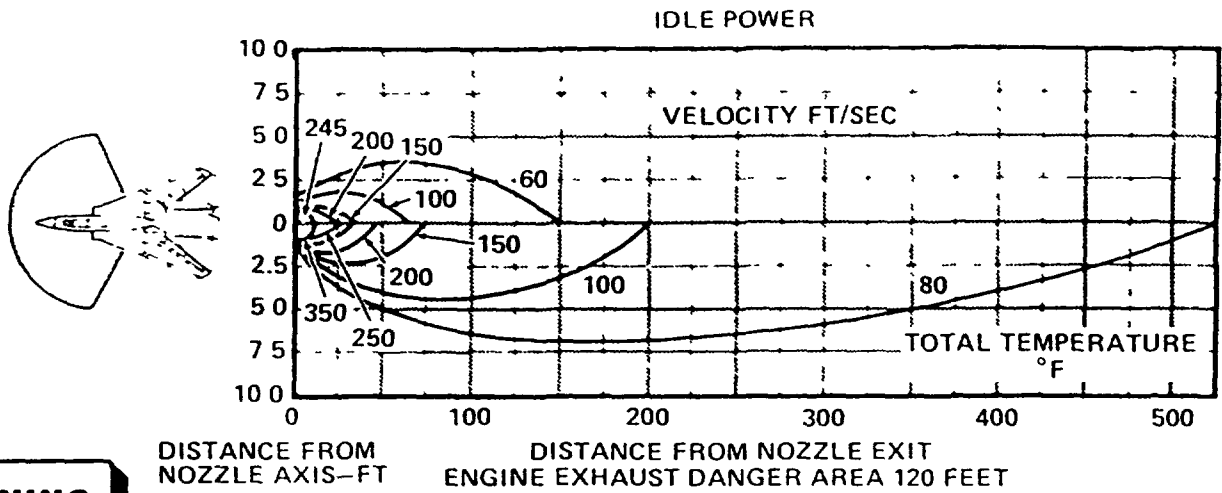

WARNING

AT HIGH TRUST SETTINGS, THE SUCTION DANGER AREA AROUND ENGINE INLETS MAY EXTEND AS FAR AS 4 FEET AFT OF THE INLET DUCT LOWER LIP.

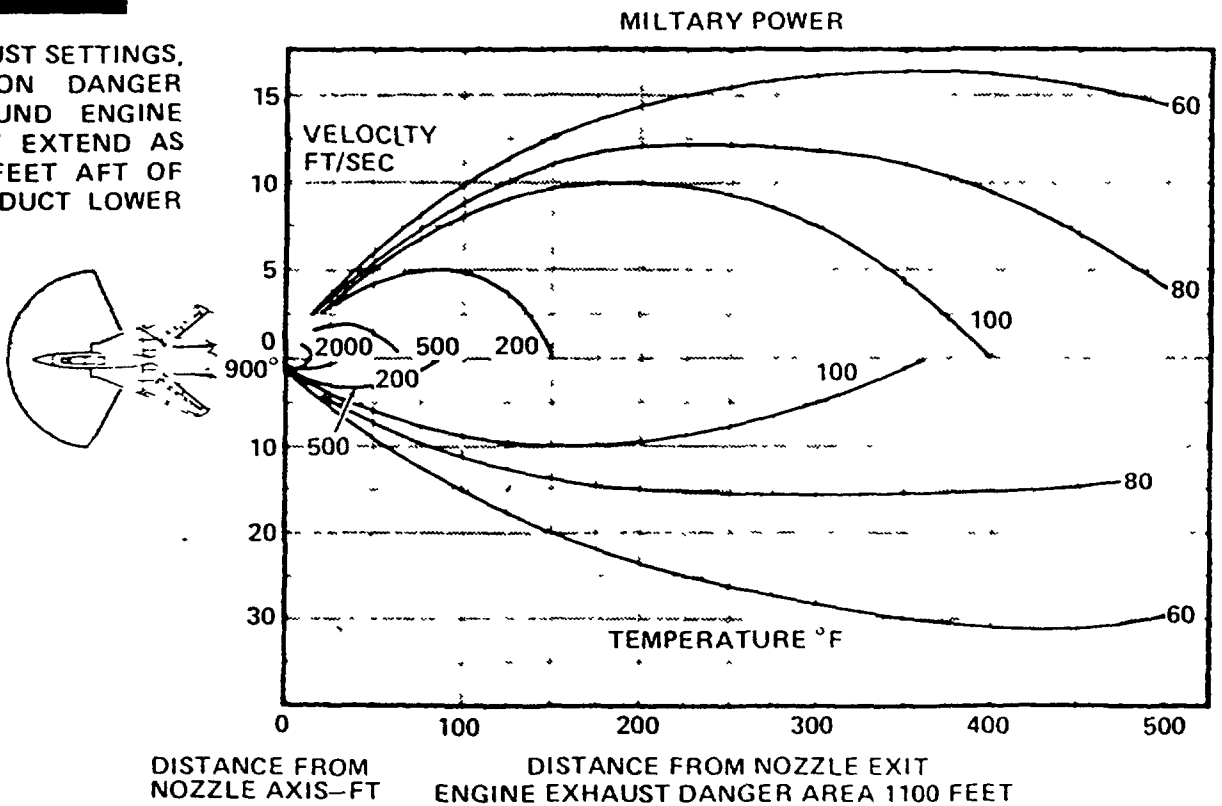

MIL-HDBK-844(AS)

AIRCRAFT: F-18

AIRCRAFT CONFIGURATION

ELECTRICAL GROUNDING/BONDING POINTS

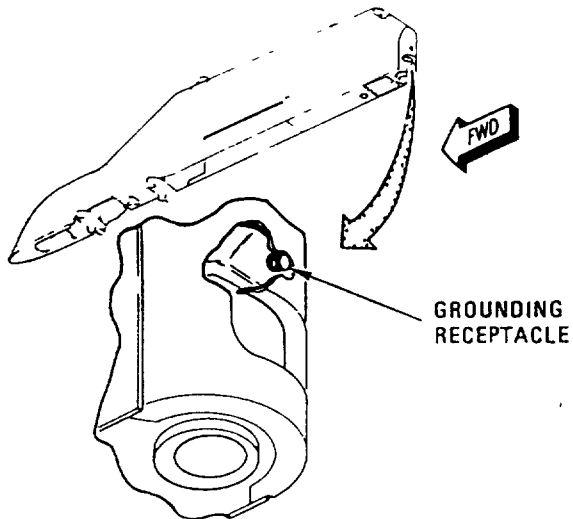

WING PYLONS

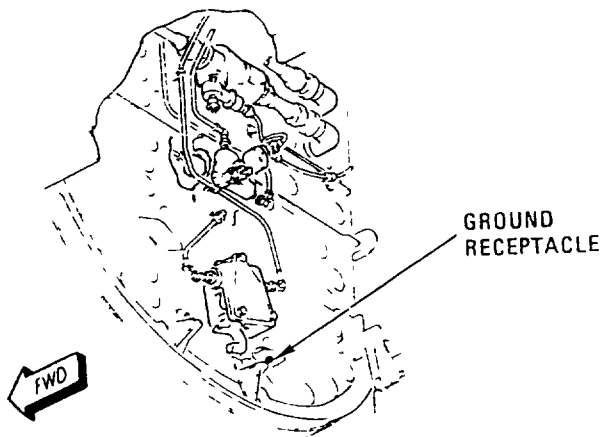
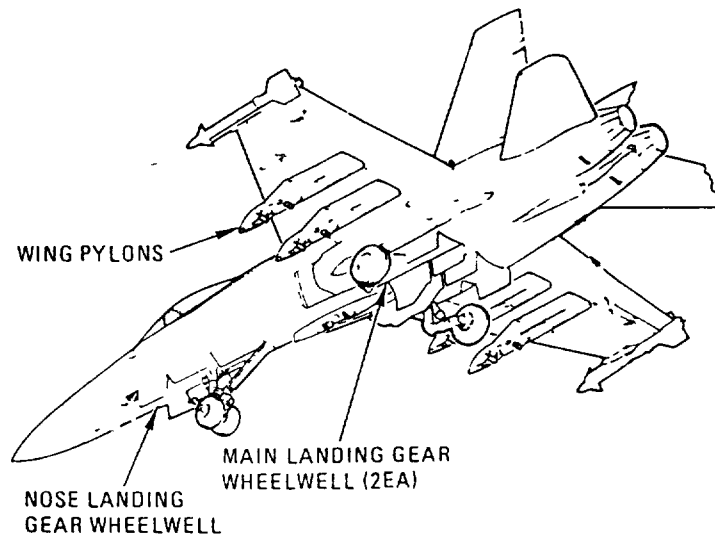

NOSE LANDING GEAR WHEELWELL

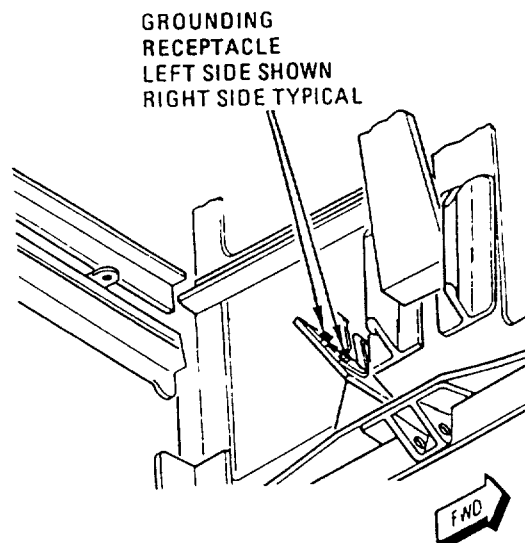

MAIN LANDING GEAR WHEELWELL

AIRCRAFT: F-18

AIRCRAFT CONFIGURATION

LOCATION OF VENTS AND DUMP MASTS

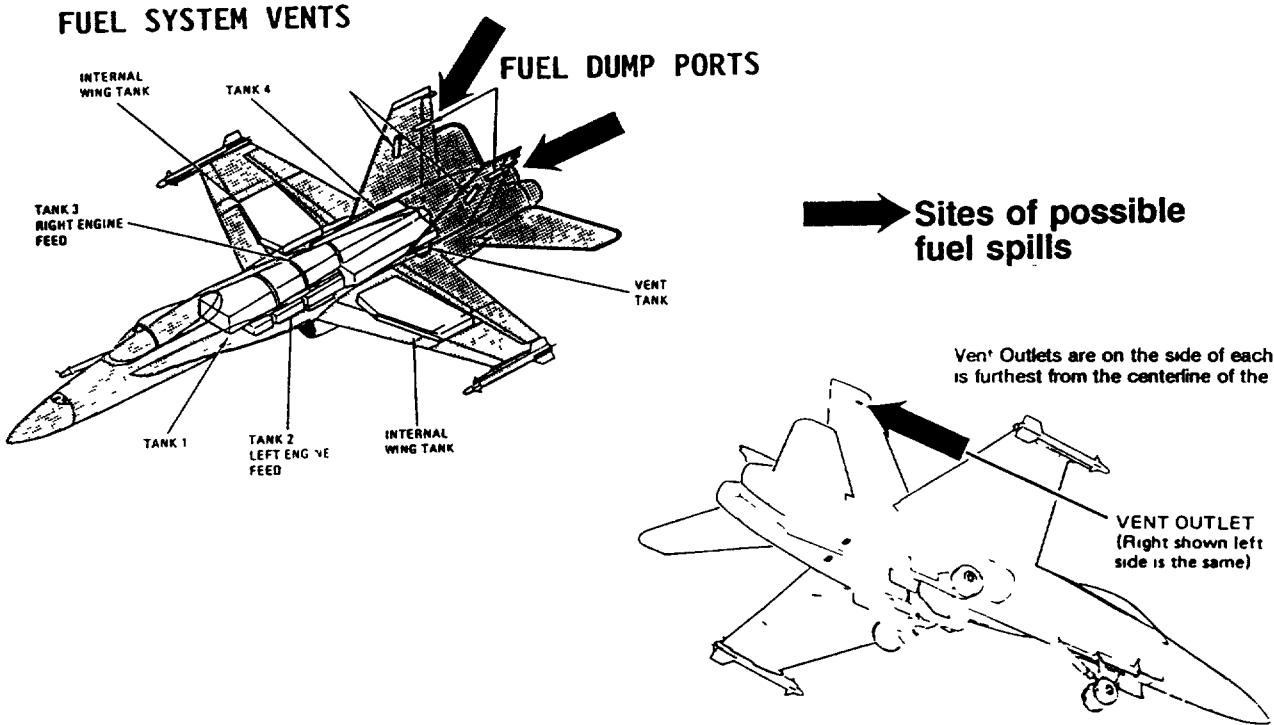

GROUND REFUELING PANEL AND RECEPTACLE

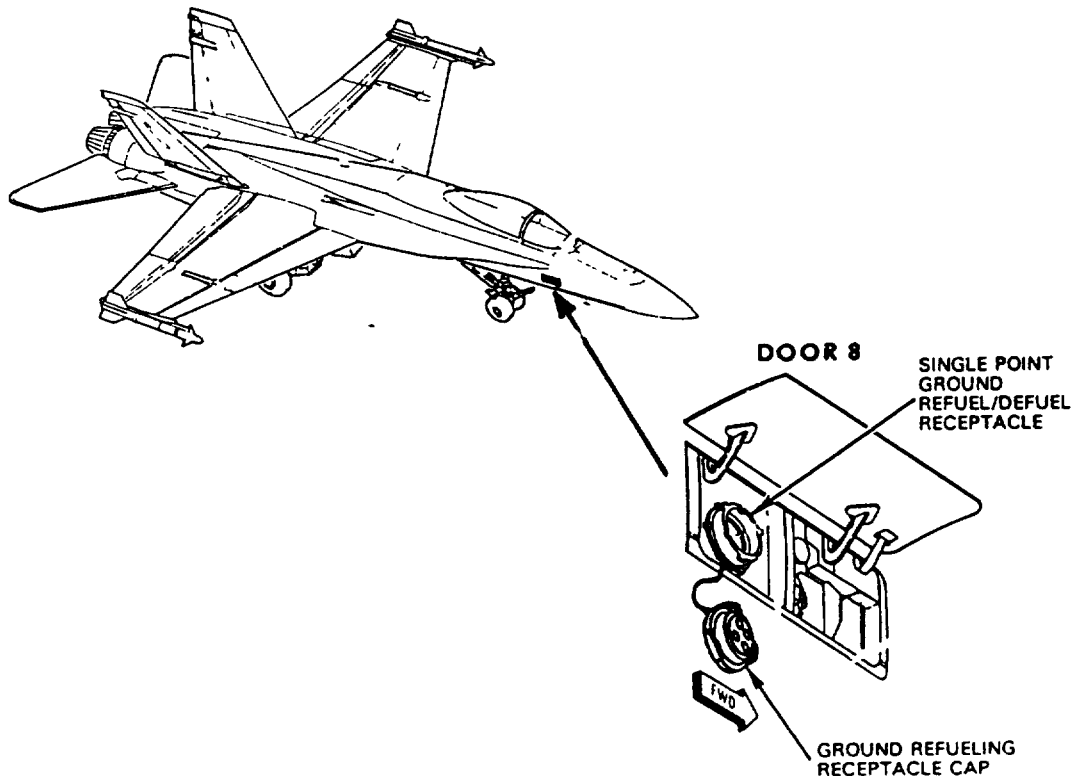

MIL-HDBK-844(AS)

AIRCRAFT: F-18**TABLE OF FUEL CAPACITIES**

Tank			Gallons
Internal	Fuselage	Number 1	418
		Number 2	263
		Number 3	206
		Number 4	532
	Wing	Left	85
		Right	85
Total Internal			1,589
External	Elliptical Wing or Centerline Tank		314
	Cylindrical Wing or Centerline Tank		330

AIRCRAFT CHARACTERISTICS

Aircraft Dimensions		Aircraft Weight
Wing Span		Maximum Gross Weight 51,900 lbs
Spread	40 ft 5 in	
	Folded 27 ft 6 in	
Length	56 ft	Maximum Footprint 315 psi
Height	15 ft 3 in	

F-18 REFUELING PROCEDURES

The following procedures cover only the refueling procedures which are unique to the F-18 aircraft, primarily the operation of the "pre-check" system. In addition to these specialized procedures, the applicable, basic refueling procedures contained in chapter 6 or 12 of the Aircraft Refueling NATOPS Manual, NAVAIR 00-80T-109, must be followed.

CAUTION

- F-18 aircraft are normally hot refueled with both engines operating. DO NOT ASSUME RIGHT ENGINE TURNED OFF until confirmation obtained.

1. Attach refueling nozzle to aircraft and place nozzle flow control handle in the open position

AIRCRAFT: F-18

2. Initiate fuel flow and observe tank pressure gage on ground refueling panel.

CAUTION

- Immediately stop fuel flow if tank pressure gage indicates increasing pressure.

3. Exercise pre-check system by moving the "Master Precheck Handle" into the up position. Observe "Fuel Flow Indicate" movement to verify that fuel flow into the aircraft stops.

a. No external tanks installed Fuel flow into the aircraft should stop in approximately 45 seconds.

b. External tank(s) installed. Wait approximately 45 seconds, then press the "Ext Tk" button on the "Fuel Check Panel". Fuel flow into the aircraft should stop within approximately 10 seconds.

CAUTION

- If fuel flow does not stop, discontinue refueling operation immediately. System failure must be investigated and resolved before hot refueling can be accomplished.

4. Return "Master Precheck Handle" to the down (off) position and continue fueling until aircraft tanks are filled and fuel flow automatically stops.

SPECIAL NOTES AIRCRAFT FUEL SYSTEM

1. Under normal conditions, all air being displaced by fuel in the tanks, including external tanks, exits the aircraft through the common "Fuel System Vent".

2. If any high level shut-off valves fail to operate correctly, fuel may spill from the "Fuel System Vents".

3. A malfunction within an external fuel tank may cause fuel to spill from the bottom center of tank (pressure relief vent).

GROUND REFUELING PANEL

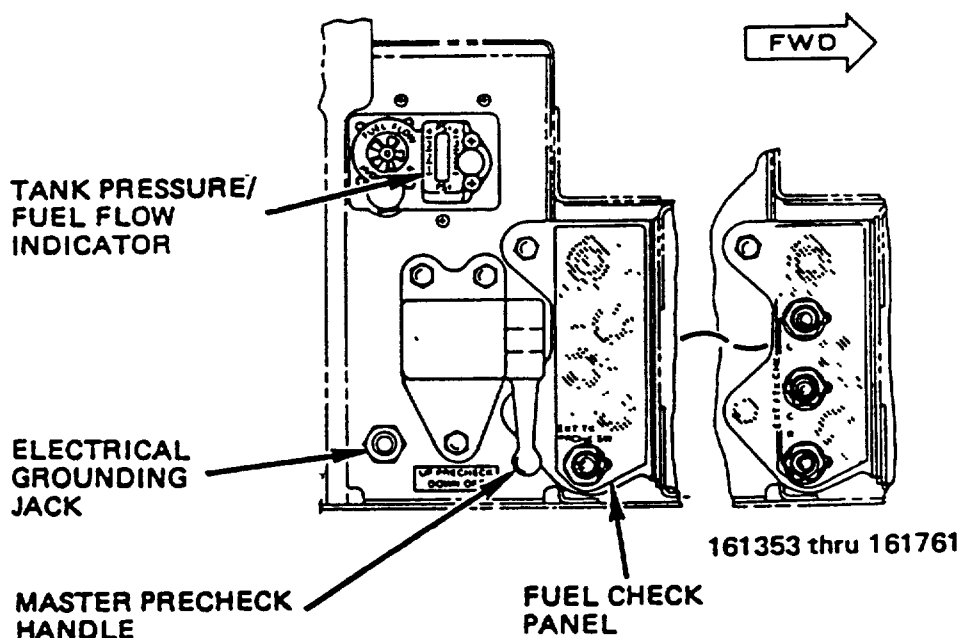

MIL-HDBK-844(AS)

AIRCRAFT: F-18

PERSONNEL DANGER ZONES

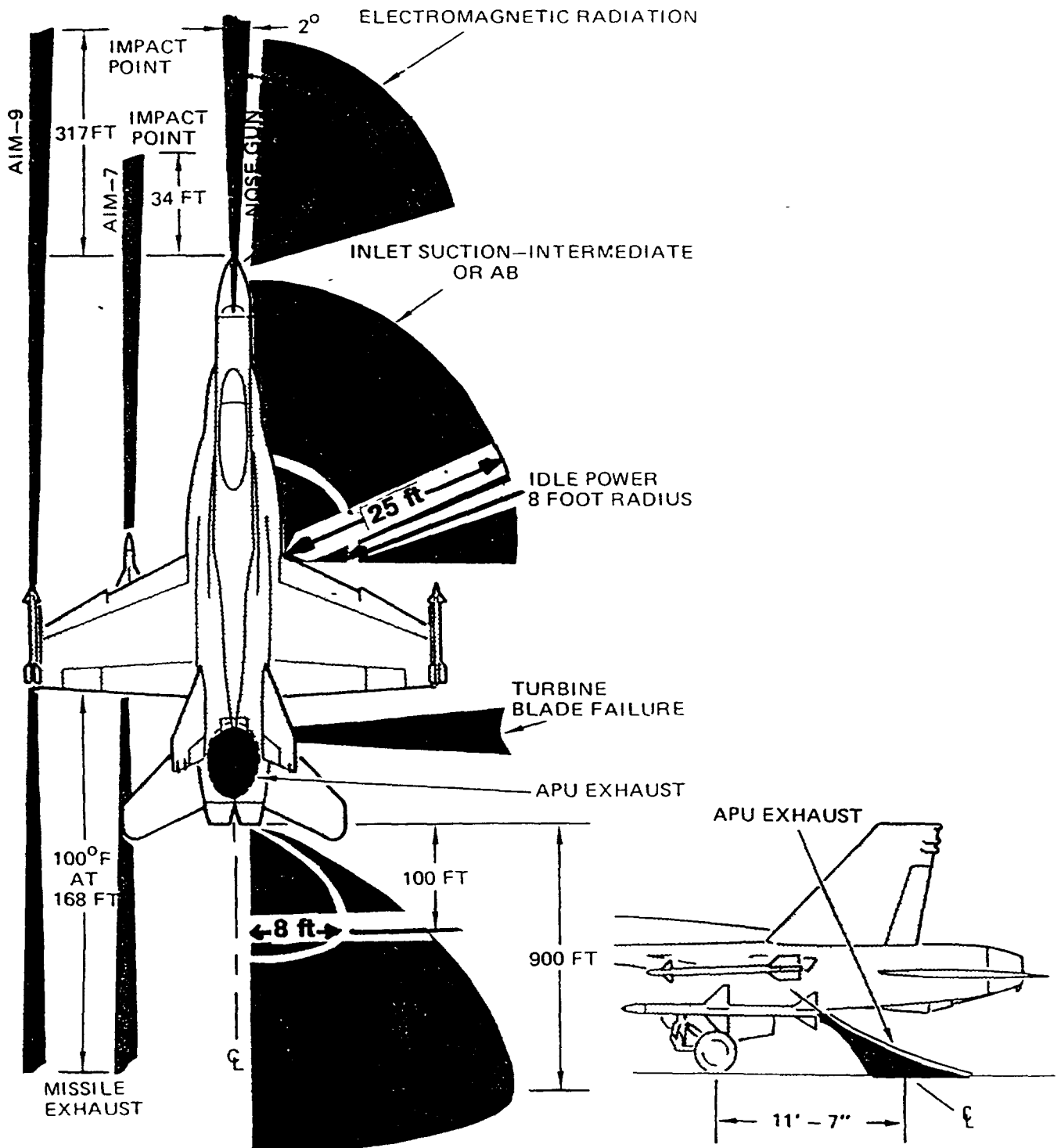

AIRCRAFT: S-3

AIRCRAFT CONFIGURATION

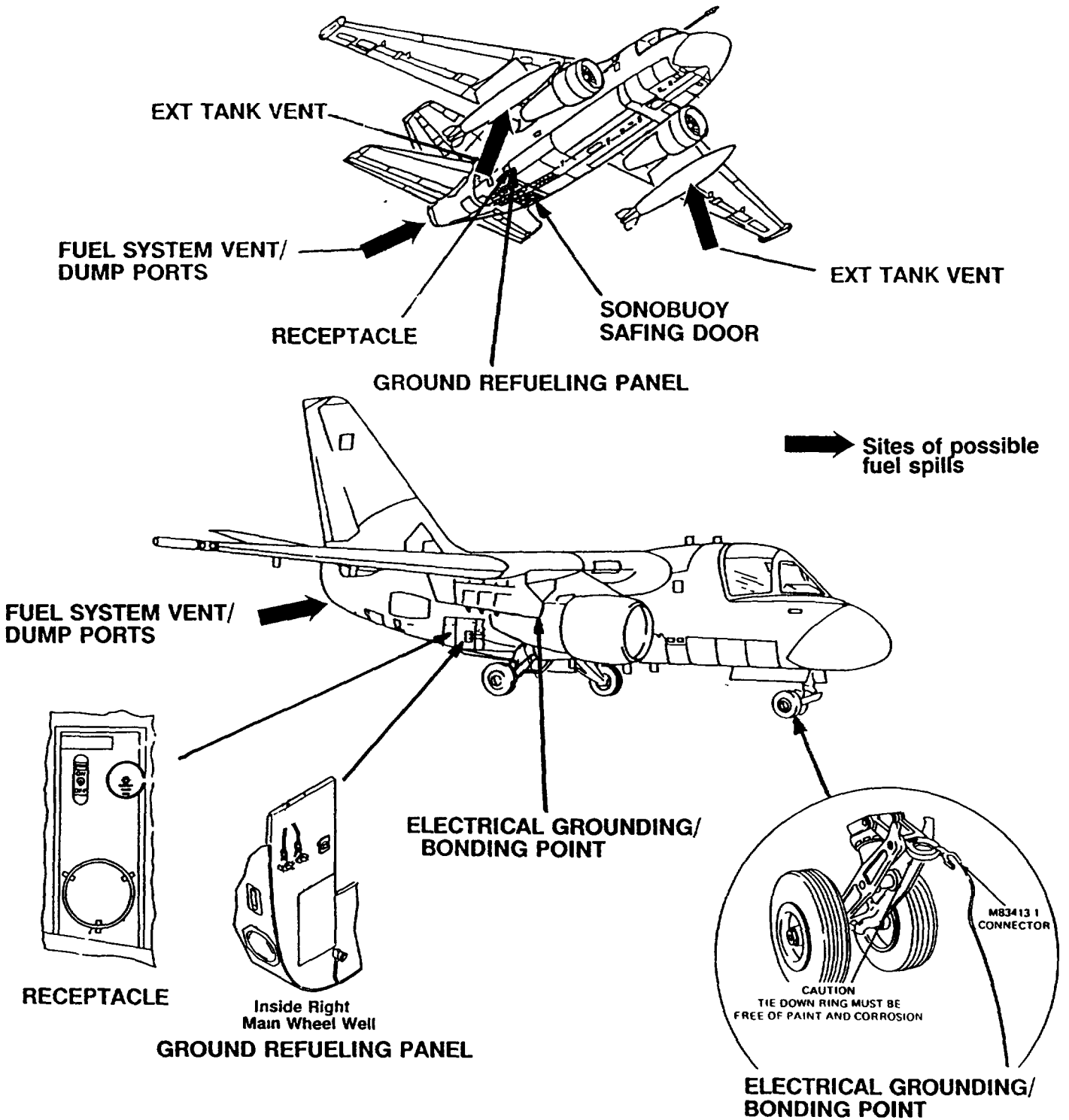

MIL-HDBK-844(AS)

AIRCRAFT: S-3**TABLE OF FUEL CAPACITIES**

Tank		Gallons
Internal	Left Feed	176.5
	Right Feed	176.5
	Left Transfer	790.0
	Right Transfer	790.0
	Total Internal	1,933.0
External	Left Pylon	265.0
	Right Pylon	265.0
Total Internal + External		2,463.0

AIRCRAFT CHARACTERISTICS

Aircraft Dimensions		Aircraft Weight
Wing Span		Maximum Gross Weight 50,000 lbs
Spread	68 ft 8 in	
	Folded 29 ft 6 in	Maximum Footprint 288 psi
Length	53 ft 4 in	
Height	22 ft 9 in	

S-3 REFUELING PROCEDURES

The following procedures cover only the refueling procedures which are unique to the S-3 aircraft, primarily the operation of the "pre-check" system. In addition to these specialized procedures, the applicable, basic refueling procedures contained in chapter 6 or 12 of the Aircraft Refueling NATOPS Manual, NAVAIR 00-80T-109, must be followed

1. Attach refueling nozzle to aircraft and place nozzle flow control handle in the open position.

2. Initiate fuel flow and observe "TANK PRESSURE INDICATOR GAUGE" on ground refueling panel (inside the right main landing gear wheel well).

CAUTION

- Sonobouy Safing Door must be opened to insure that the jetison system has been disarmed.

CAUTION

- Immediately stop fuel flow if indicator moves into the red band

AIRCRAFT: S-3

labeled "STOP REFUELING".

3. Exercise precheck system by twisting and holding both "PRECHECK VALVES" on the ground refueling panel in the "OPEN" position. Fuel flow into the aircraft should stop within 20 seconds.

CAUTION

- If fuel flow does not stop, discontinue refueling operation immediately. System failure must be investigated and resolved before hot refueling can be accomplished.
- 4 "PRECHECK VALVES" are spring loaded to the "CLOSED" position. Release them and continue fueling until aircraft tanks are filled and fuel flow automatically stops.

5. If external tanks are installed, they can be refueled by turning the "EXTERNAL TANK FUELING SWITCH" to the "ON" position. This switch should be placed in the "ON" position only after the high level shutoff valves in the internal tanks have been tested using the "PRECHECK VALVES" in steps 3 and 4 above. Return this switch in the "OFF" position at the conclusion of the refueling operation.

SPECIAL NOTES AIRCRAFT FUEL SYSTEM

1. Under normal conditions, all air being displaced by fuel in the internal tanks exits the aircraft through the common "Fuel System Vent Port".
2. If any high level shutoff valves fail to operate correctly, fuel may spill from the "Fuel System Vent Port" and/or tank(s) may rupture.
3. A malfunction within the external fuel tanks may cause fuel to spill from the bottom center of the external tank (pressure relief vent).
4. The Precheck system does not exercise the high level shutoff valves in the external tanks.

GROUND REFUELING PANEL

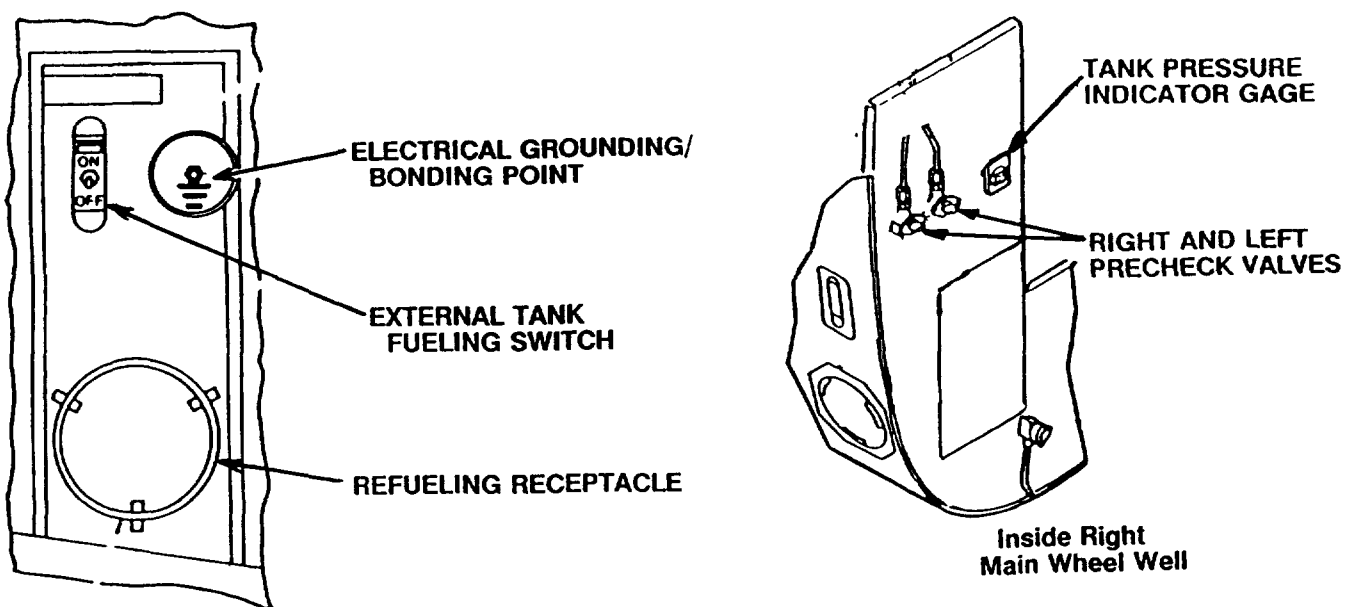

AIRCRAFT: S-3

PERSONNEL DANGER ZONES

HAZARDOUS GROUND OPERATIONS

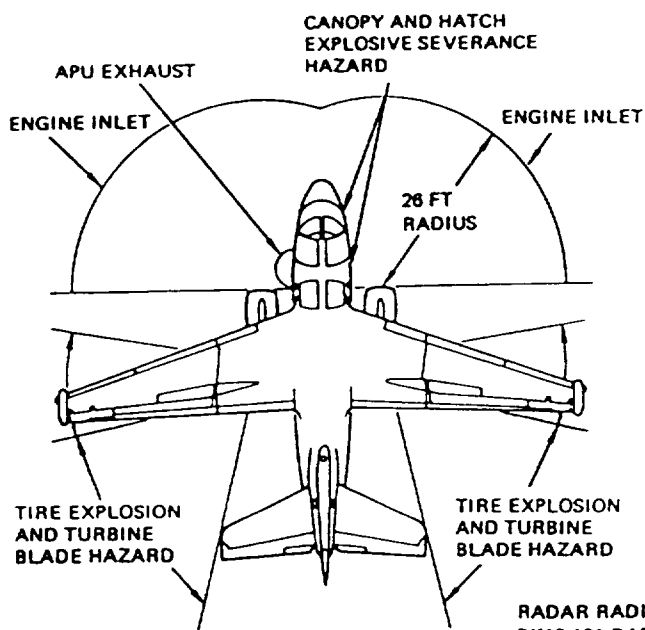

WARNING

RADAR RADIATION IS HAZARDOUS WITHIN THE DISTANCES NOTED.

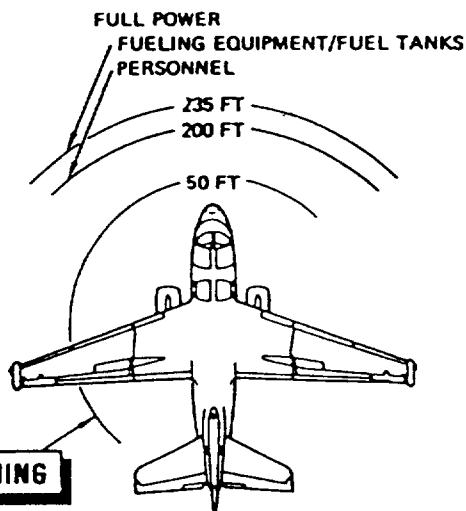

WARNING

RADAR RADIATION AT FULL POWER, WITH THE BK18-101 RADAR INHIBITOR PLUG INSTALLED, IS HAZARDOUS TO PERSONNEL, FUEL EQUIPMENT AND FUEL TANKS CLOSER THAN 50 FEET

ENGINE BLAST AND TEMPERATURE AREAS

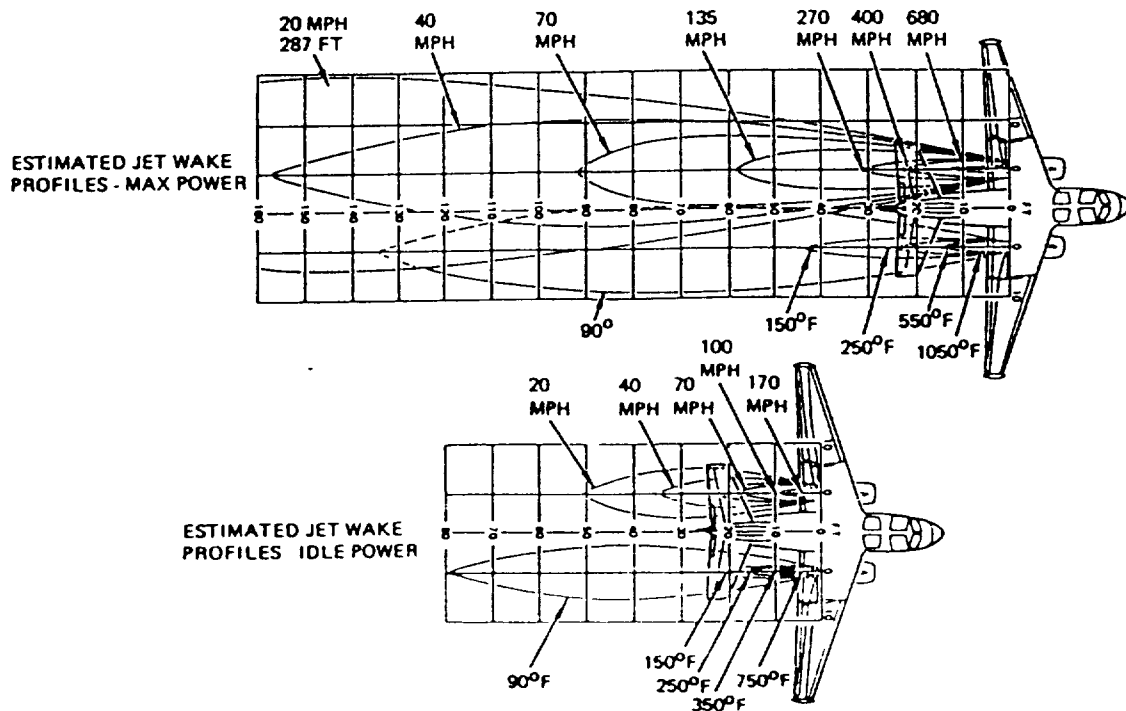

AIRCRAFT: P-3

AIRCRAFT CONFIGURATION

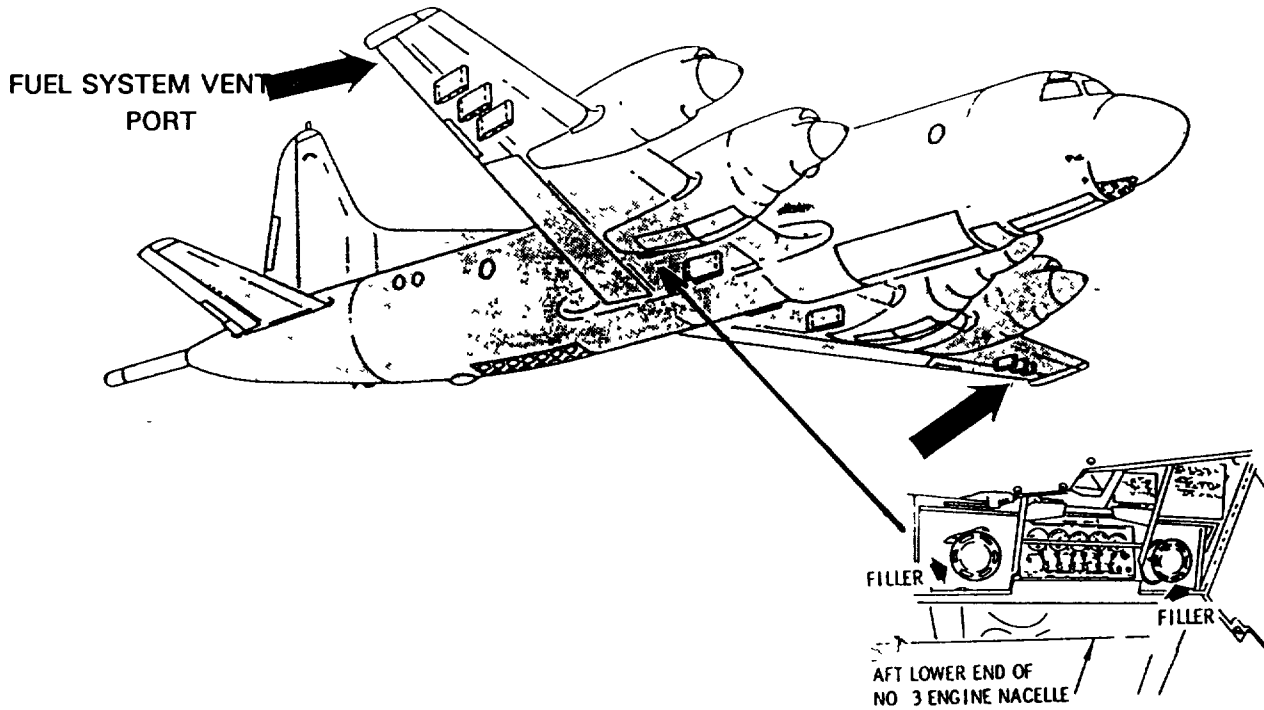

GROUND REFUELING PANEL AND RECEPTACLE

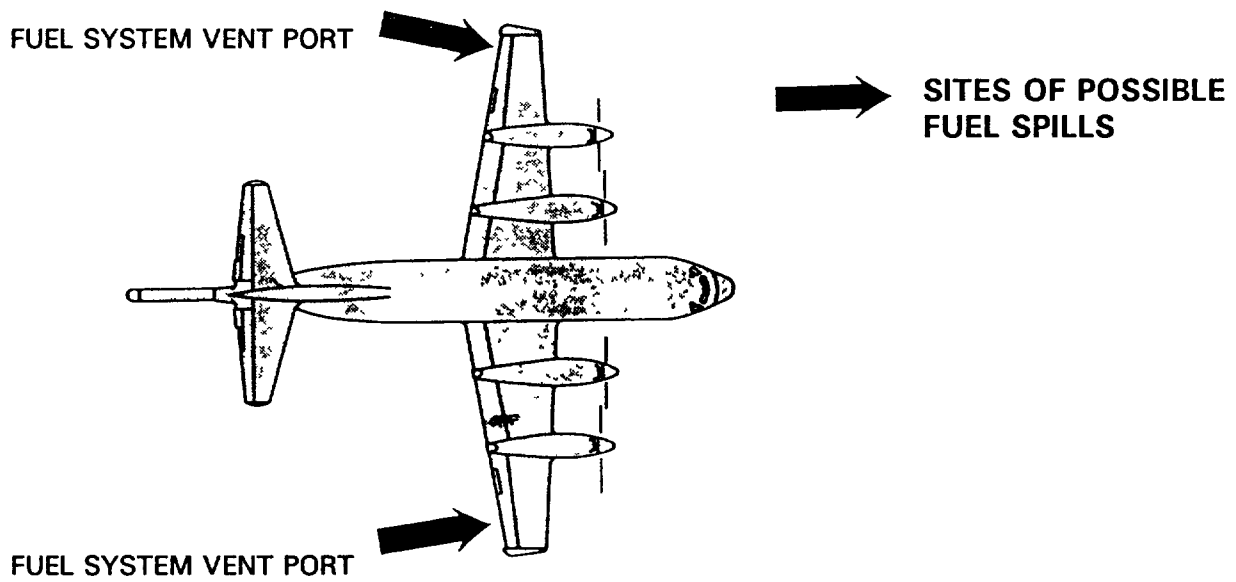

MIL-HDBK-844(AS)

AIRCRAFT: P-3

TABLE OF FUEL CAPACITIES

Tank		Gallons
Outboard	No. 1	1,606
	No. 4	1,606
Inboard	No. 2	1,671
	No. 3	1,671
No. 5		2,646
Total Internal		9,200

AIRCRAFT CHARACTERISTICS

Aircraft Dimensions	Aircraft Weight
Wing Span 99 ft 8in	Maximum Gross Weight 139,760 lbs
Length 116 ft 10 in	Maximum Footprint 250 psi
Height 34 ft 3 in	

P-3 REFUELING PROCEDURES

The following procedures cover only the refueling procedures which are unique to the P-3 aircraft, primarily the operation of the "pre-check" system. In addition to these specialized procedures, the applicable, basic refueling procedures contained in chapter 6 or 12 of the Aircraft Refueling NATOPS Manual, NAVAIR 00-80T-109, must be followed.

1. Open Ground Refueling Panel access door.
2. Remove receptacle cap, attach refueling nozzle, open nozzle to the fully open and locked position, and initiate fuel flow.
3. Locate the Precheck system valve test switches on the ground refueling panel. Hold left "VALV CONT" switch to "PRI CLOSE" and the right "VALV CONT" switch to "SEC CLOSE". Fuel flow into the aircraft should stop within a few seconds.
4. Release switches and fuel flow should resume.
5. Repeat the precheck process in step three above, this time holding the left "VALV CONT" switch to "PRI CLOSE".

"FUEL SYSTEM VENTS". If no venting is indicated, cease fueling operation immediately.

WARNING

- Ensure that air is venting from

AIRCRAFT: P-3

CAUTION

- If fuel flow does not stop step 3 or 5 above, discontinue hot refueling operation immediately. System failure must be investigated and resolved before hot refueling can be accomplished.
6. Release switches and refuel aircraft until fuel flow into the aircraft stops and the fuel quantity gage on the ground refueling panel indicates the tanks are full.

SPECIAL NOTES AIRCRAFT FUEL SYSTEM

1. Under normal conditions, all air being displaced by fuel in the tanks exits the aircraft through the common "Fuel System Vent Port" which is located on each side of aircraft.
2. If any high level shut-off valves fail to operate correctly, fuel may spill from one of the "Fuel System Vent Port". In addition, the fuel tanks, which are located in the Stubwings, may rupture and spill fuel.

GROUND REFUELING PANEL

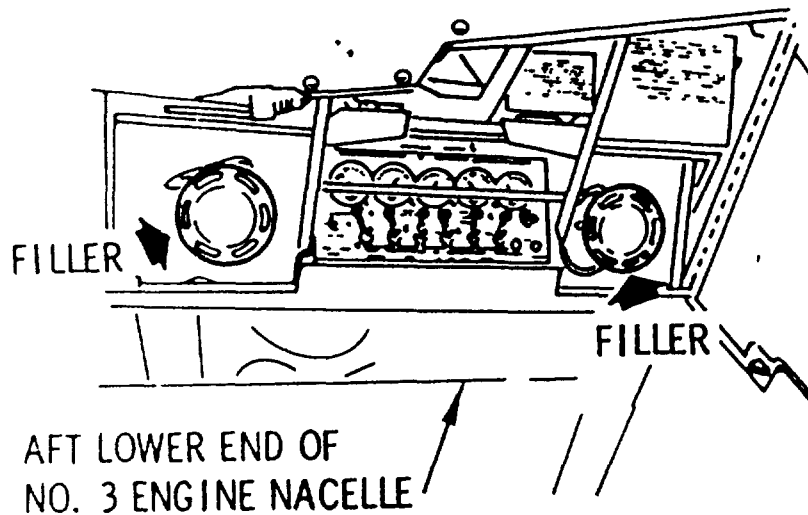

MIL-HDBK-844(AS)

AIRCRAFT: P-3

PERSONNEL DANGER ZONES

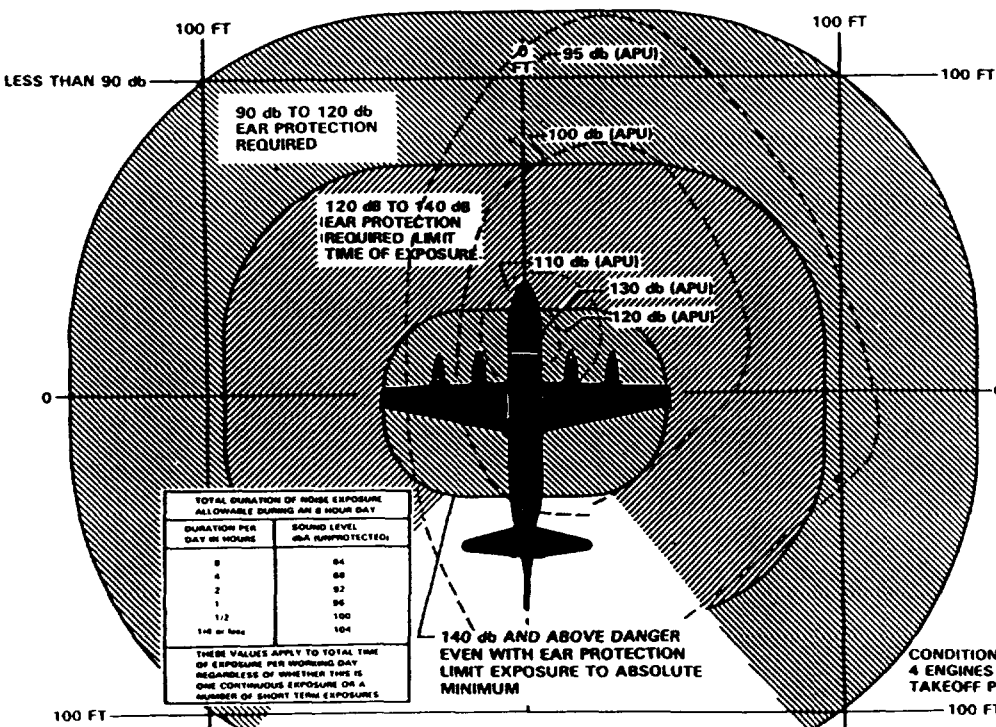
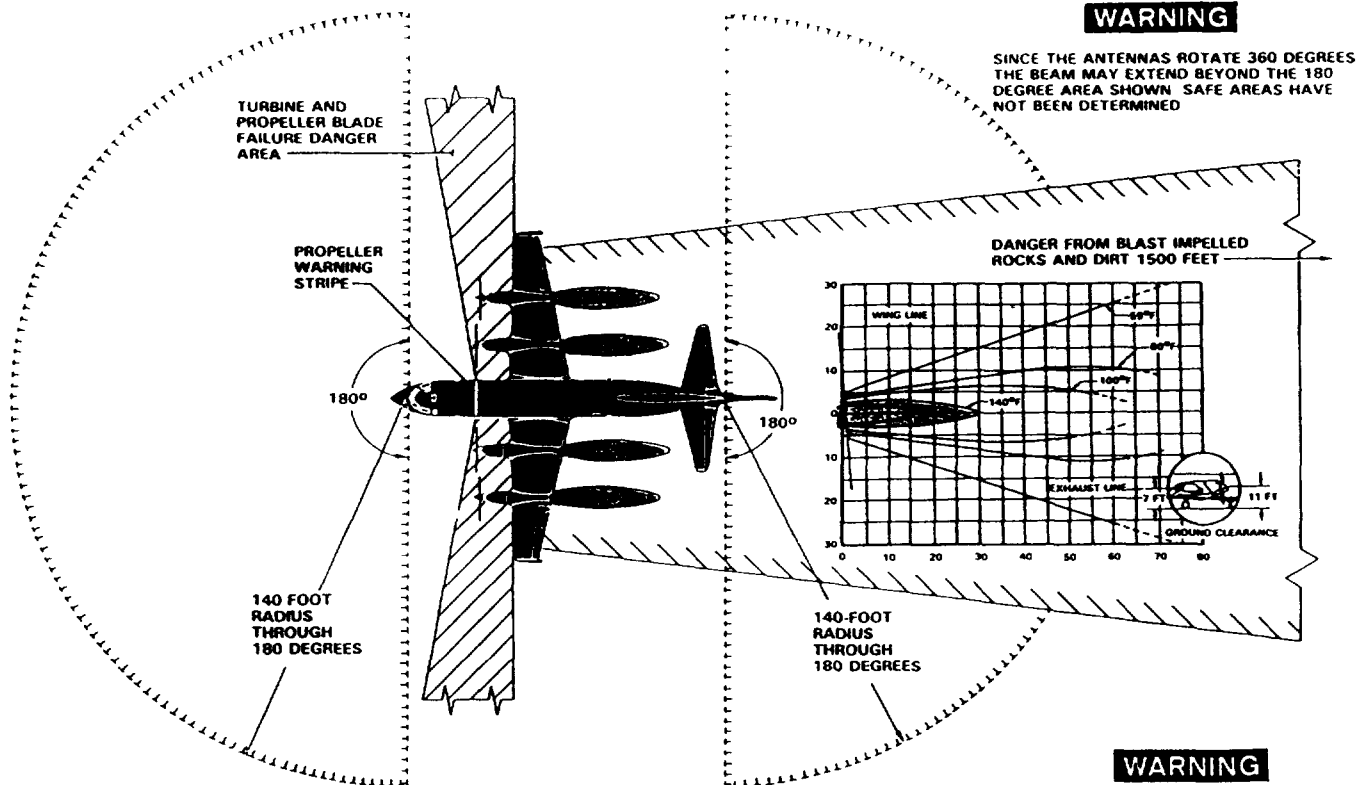

- WARNING**
- DO NOT APPLY HIGH VOLTAGE TO RADAR ANTENNA WITH ANT/DUMMY LOAD SWITCH IN ANT POSITION WHEN FUEL TRUCKS OR FUELING OPERATIONS ARE WITHIN A RADIUS OF 140 FEET FROM RADAR ANTENNA.
 - PERSONNEL MUST BE WARNED TO STAY 75 FEET FROM A RADAR ANTENNA, WHEN HIGH VOLTAGE IS APPLIED AND ANTENNA IS SELECTED. (200 FEET FOR THE AN/AP 137 (V) 2)
 - HERO ORDNANCE MUST REMAIN AT LEAST 140 FEET FROM THE ANTENNA WHEN HIGH VOLTAGE IS APPLIED AND ANTENNA IS SELECTED. (250 FEET FOR THE AN/AP 137 (V) 2)

- NOTE**
- TO ACCURATELY ASSESS THE EFFECTIVENESS OF HEARING CONSERVATION MEASURES ALL PERSONNEL EXPOSED TO NOISE HAZARDOUS AREA SHOULD RECEIVE ROUTINE MONITORING AUDIOMETRY IN ACCORDANCE WITH OPNAVINST 6260.6 SERIES
 - SOUND INTENSITY LEVELS OF 85 DBA AND HIGHER HAVE BEEN RECORDED INSIDE P-3 AIRCRAFT DURING FLIGHT. CONSIDERATION SHOULD BE GIVEN TO WEARING HEARING PROTECTION WHILE OFF HEADSET AS UNPROTECTED EXPOSURE MAY RESULT IN TEMPORARY OR PERMANENT HEARING LOSS
 - A COMBINATION OF INSERT AND CIR CUMRAURAL HEARING PROTECTION DEVICES SHOULD BE UTILIZED WHEN SOUND LEVELS EXCEED 100 DBA

AIRCRAFT: H-1

AIRCRAFT CONFIGURATION

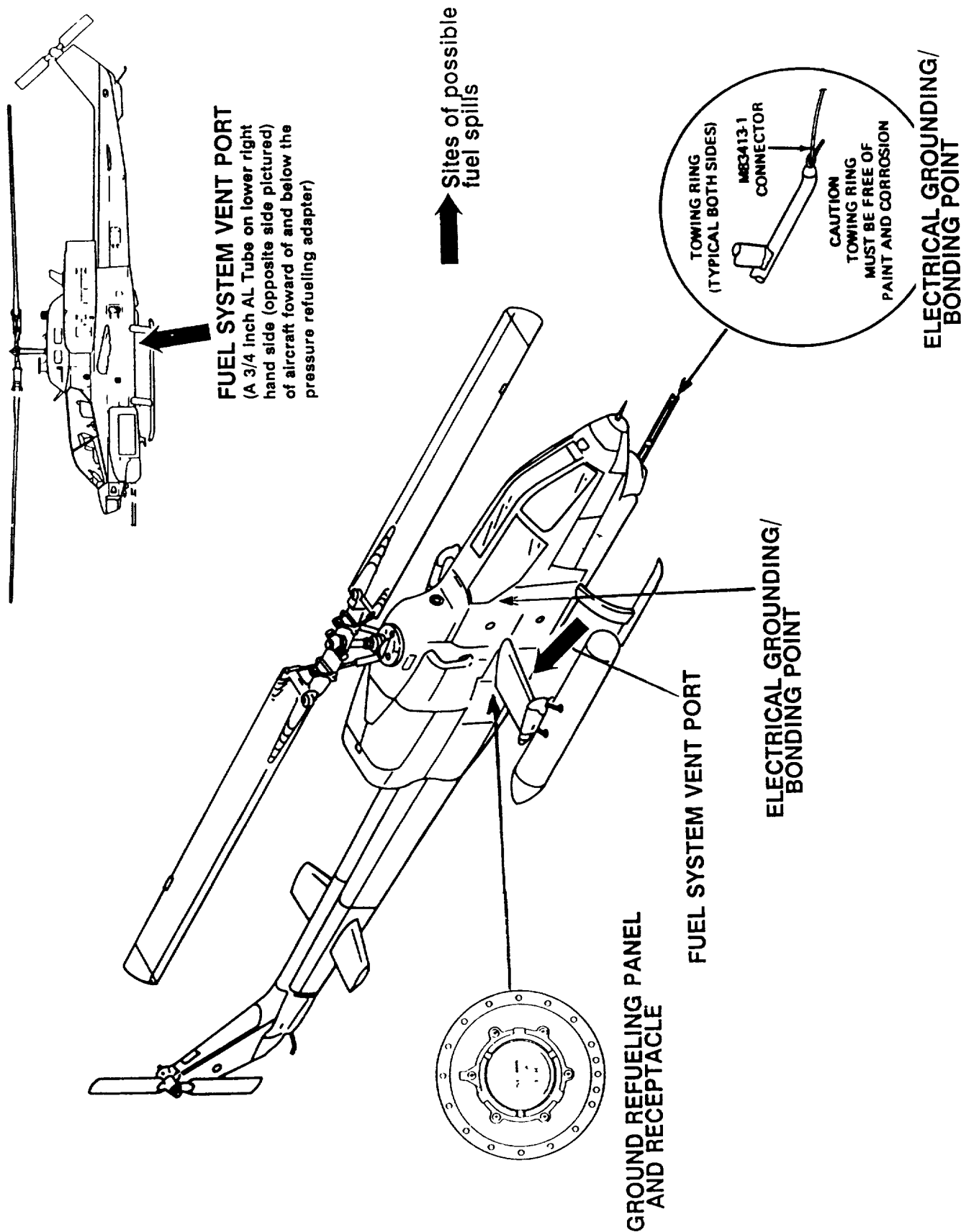

MIL-HDBK-844(AS)

AIRCRAFT: H-1

TABLE OF FUEL CAPACITIES

Tank		Gallons
Internal	Forward	190
	Aft	123
	Total	313
External Wing Tanks (each)	2 Maximum	100
	4 Maximum	77

AIRCRAFT CHARACTERISTICS

Aircraft Dimensions		Aircraft Weight
Fuselage Width	10 ft 9 in	Maximum Gross Weight 14,750 lbs
Length	58 ft	
Height	14 ft 2 in	Maximum Footprint 70 psi

H-1 REFUELING PROCEDURES

The following procedures cover only the refueling procedures which are unique to the H-1 aircraft, primarily the operation of the "pre-check" system. In addition to these specialized procedures, the applicable, basic refueling procedures contained in chapter 6 or 12 of the Aircraft Refueling NATOPS Manual, NAVAIR 00-80T-109, must be followed

1. Remove receptacle cap, attach refueling nozzle, open nozzle to the fully open and locked position, and initiate fuel flow.

WARNING

- Ensure that air is venting from "FUEL SYSTEM VENTS". If no venting is indicated, cease fueling operation immediately.

2 Exercise the Precheck system. Press and hold one

of the "PRECHECK" plungers on the rim of the fueling valve. Fuel flow into the aircraft should stop within 20 seconds. Release the "PRECHECK" plunger and fuel flow should resume into the aircraft

3. Repeat the last step this time holding the other "PRECHECK" plunger down.

WARNING

- Flow of fuel while either of the "PRECHECK" plungers are held down indicates a failed shutoff valve. Stop refueling immediately. System failure must be investigated and resolved before hot refueling can be accomplished.

4. Release both "PRECHECK" plungers and refuel aircraft

AIRCRAFT: H-1

5. Continue fueling until fuel flow stops automatically.

SPECIAL NOTES AIRCRAFT FUEL SYSTEM

1. Under normal conditions, all air being displaced by fuel in the tanks exits the aircraft through the common "Fuel System Vent Port" which is a 3/4 inch AL Tube on the lower right hand side of the aircraft forward of and below the pressure refueling adapter. It is almost on the bottom of the aircraft.

2. If any high level shut-off valves fail to operate correctly, fuel may spill from one of the "Fuel System Vent Port". In addition, the fuel tanks may rupture and spill fuel

3. The external tanks can not be pressure refueled. Each external tank must be gravity refueled separately.

GROUND REFUELING PANEL

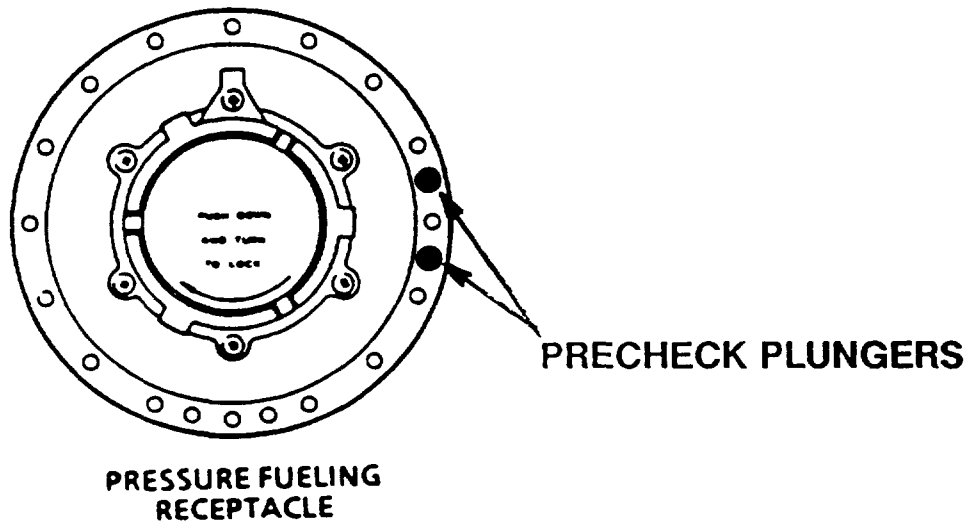

MIL-HDBK-844(AS)

AIRCRAFT: H-1

PERSONNEL DANGER ZONES

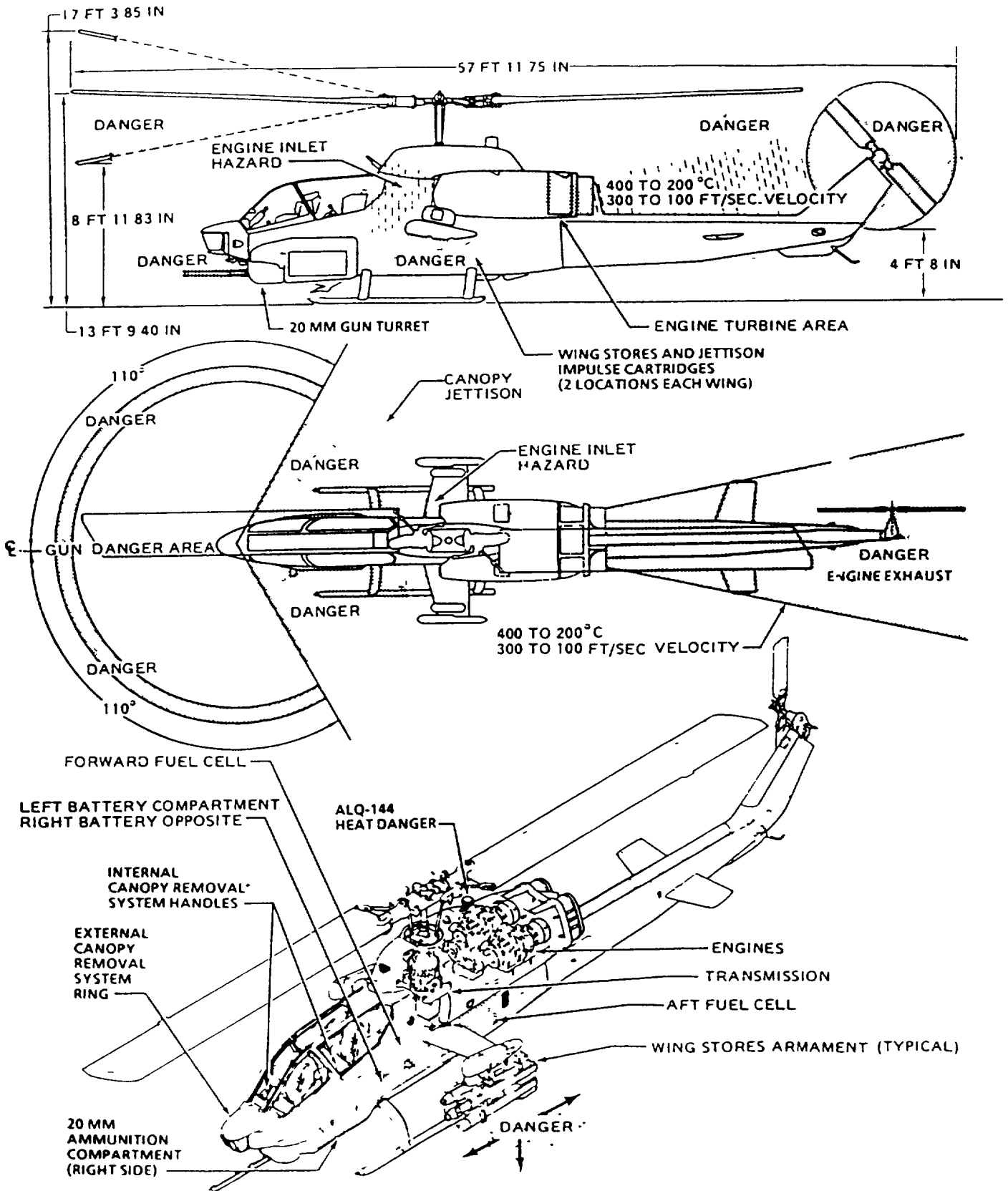

AIRCRAFT: H-2

AIRCRAFT CONFIGURATION

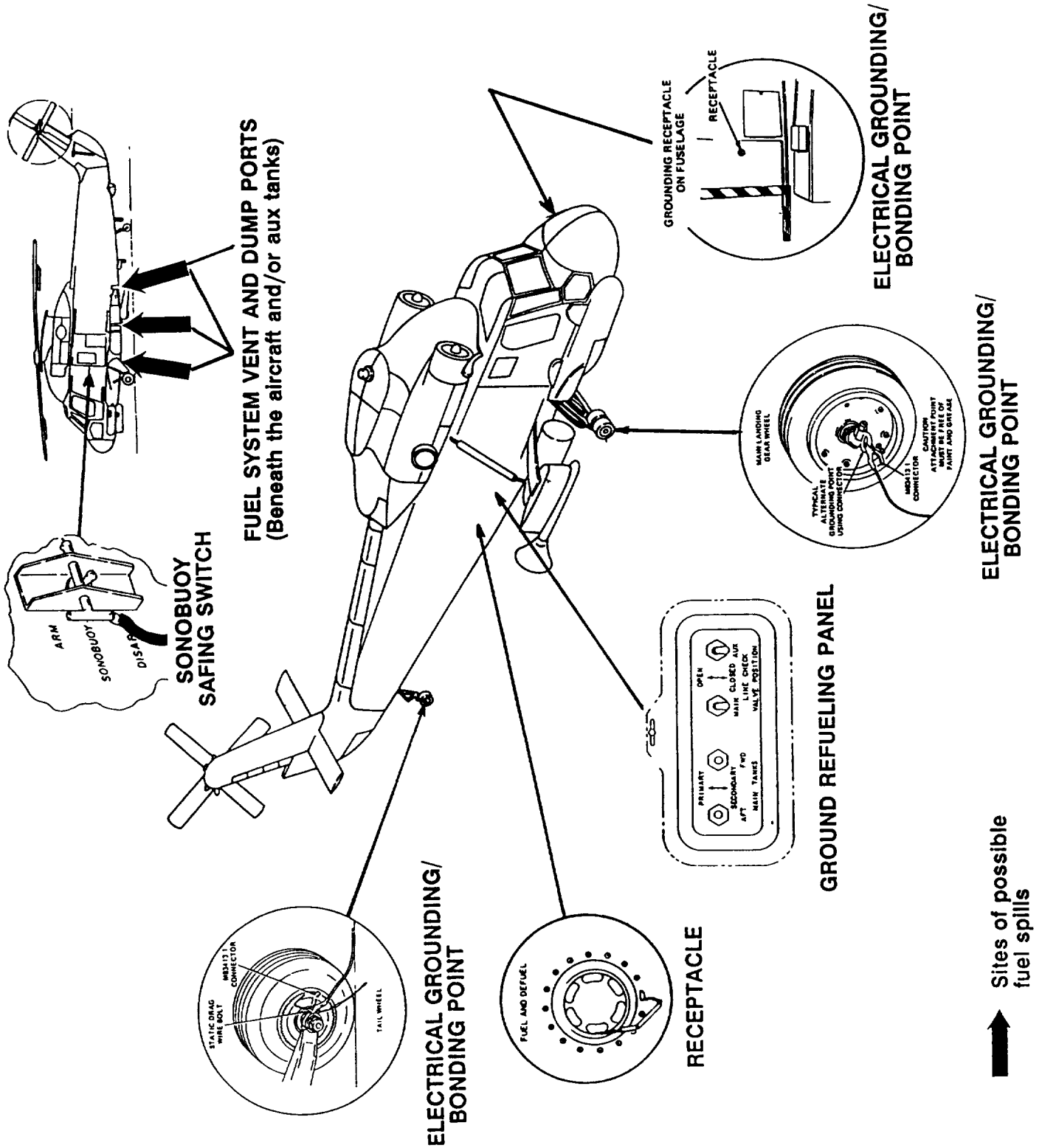

MIL-HDBK-844(AS)

AIRCRAFT: H-2

TABLE OF FUEL CAPACITIES

Tank		Gallons	
	Internal	Sump	99
		Aft	176
	Total		275
Ext Aux Tanks (each)	Before AFC 293		59
	After AFC 293		99
Totals (With 2 Aux Tanks)	Before AFC 293		393
	After AFC 293		473

AIRCRAFT CHARACTERISTICS

Aircraft Dimensions	Aircraft Weight
Fuselage Width 12 ft	Maximum Gross Weight 13,500 lbs
Length 52 ft 0.3 in	Maximum Footprint 225 psi
Height 14 ft 4.3 in	

H-2 REFUELING PROCEDURES

The following procedures cover only the refueling procedures which are unique to the H-2 aircraft, primarily the operation of the "pre-check" system. In addition to these specialized procedures, the applicable, basic refueling procedures contained in chapter 6 or 12 of the Aircraft Refueling NATOPS Manual, NAVAIR 00-80T-109, must be followed.

CAUTION

- Sonobouy Safing Switch on the SH-3 aircraft must be placed in the "DISARM" position prior to the initiation of the hot refueling operation.

1. Remove receptacle cap and attach refueling nozzle
2. Open Ground Refueling Panel door. Place the "MAIN" and "AUX" "LINE SWING CHECK VALVE SWITCHES", in the "CLOSED" position.
3. Initiate fuel flow into the aircraft.
4. Exercise the Precheck system Press and hold both "PRECHECK SWITCHES" on the Ground Refueling Panel to "SECONDARY" position Fuel flow into the aircraft should stop within 20 seconds. Repeat the last step this time holding both "PRECHECK SWITCHES" in the primary holding position.

AIRCRAFT: H-2

WARNING

- Flow of fuel while precheck switches are in the "SECONDARY" or "PRIMARY" positions indicates a failed shutoff valve. Stop refueling immediately. System failure must be investigated and resolved before hot refueling can be accomplished.
- Return both "PRECHECK SWITCHES" on Ground Refueling Panel to their normal positions.
 - Stop the flow of fuel into the aircraft by closing the poppet valve on the aircraft refueling nozzle.
 - Place the "AUX" and "MAIN" "LINE WING CHECK VALVE SWITCHES" in the "OPEN" position
 - Open refueling nozzle poppet valve and refuel aircraft.

- Continue fueling until fuel flow stops automatically.

SPECIAL NOTES AIRCRAFT FUEL SYSTEM

- Under normal conditions, all air being displaced by fuel in the tanks exits the aircraft through the common "Fuel System Vent Port" which are located on the bottom of the aircraft and the auxiliary tanks (if installed).
- If any high level shut-off valves fail to operate correctly, fuel may spill from one of the "Fuel System Vent Port". In addition, the fuel tanks may rupture and spill fuel.
- The "LINE WING CHECK VALVE SWITCHES" can be used to selectively refuel only the main internal tanks on the aircraft. Place both of these switches in the "OPEN" position to obtain maximum fuel load (including auxiliary tanks).

GROUND REFUELING PANEL

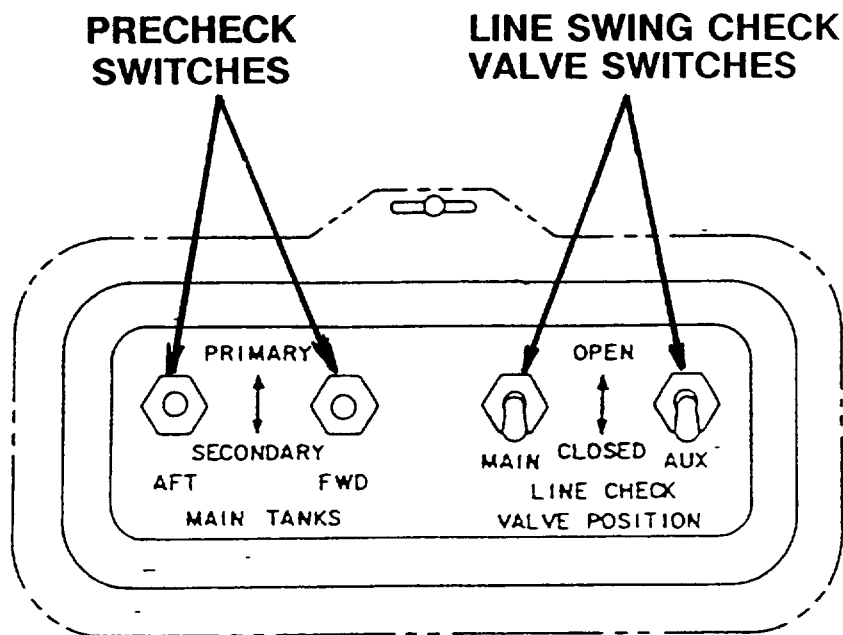

MIL-HDBK-844(AS)

AIRCRAFT: H-2

PERSONNEL DANGER ZONES

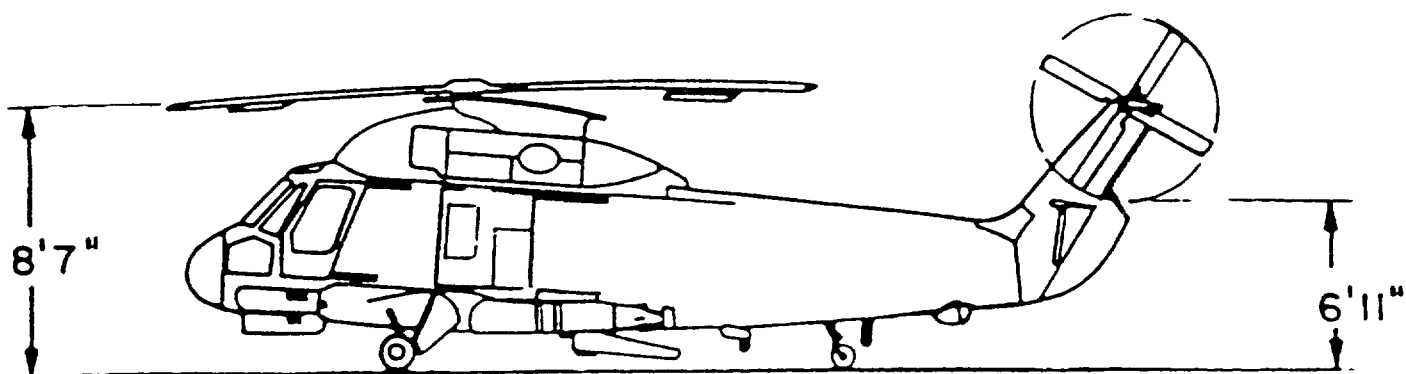

AIRCRAFT: H-3

AIRCRAFT CONFIGURATION

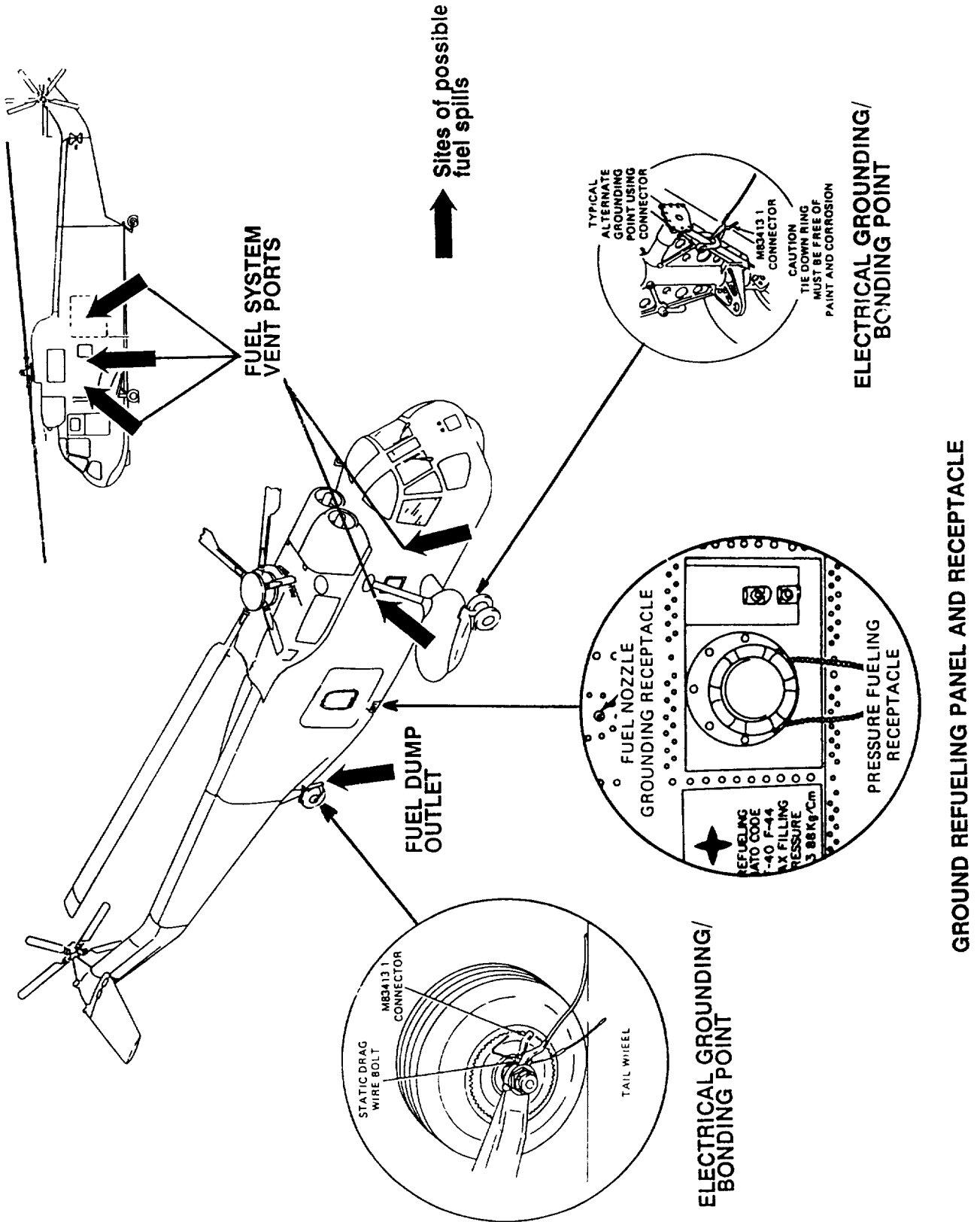

MIL-HDBK-844(AS)

AIRCRAFT: H-3

TABLE OF FUEL CAPACITIES

Tank		Gallons
Internal	Forward	341
	Aft	344
Total		685

AIRCRAFT CHARACTERISTICS

Aircraft Dimensions		Aircraft Weight
Fuselage Width	14 ft	Maximum Gross Weight 20,000 lbs
Length	72 ft 8 in	
Height	16 ft 10 in	Maximum Footprint 90 psi

H-3 REFUELING PROCEDURES

The following procedures cover only the refueling procedures which are unique to the H-3 aircraft, primarily the operation of the "pre-check" system. In addition to these specialized procedures, the applicable, basic refueling procedures contained in chapter 6 or 12 of the Aircraft Refueling NATOPS Manual, NAVAIR 00-80T-109, must be followed.

1. Open Ground Refueling Panel access door. (VH-3 only)
2. Remove receptacle cap, attach refueling nozzle, open nozzle to the fully open and locked position, and initiate fuel flow.
3. Press and hold the switch on the Ground Refueling Panel labeled "PRI TEST". Fuel flow should stop within 10 seconds.
4. Release the "PRI TEST" switch and resume fuel flow.
5. Repeat the precheck process in step four above, this time pressing and holding the "SEC TEST" switch.

Again fuel flow should stop within 10 seconds.

CAUTION

- If fuel flow does not stop in steps 3 or 5 above, discontinue hot refueling operation immediately. System failure must be investigated and resolved before hot refueling can be accomplished.
6. Release precheck switches and refuel aircraft until fuel flow into the aircraft automatically stops indicating the aircraft's tanks are full.

SPECIAL NOTES AIRCRAFT FUEL SYSTEM

1. Under normal conditions, all air being displaced by fuel in the tanks exits the aircraft through the common "Fuel System Vent Port" which is located on the cabin skin in the approximate places indicated on the aircraft configuration diagram.

AIRCRAFT: H-3

2. If any high level shut-off valves fail to operate correctly, fuel may spill from one of the "Fuel System Vent Port". In addition, the fuel tanks may rupture and spill fuel.

3. If externally mounted auxillary tanks are installed, they can only be refueled by gravity. It is not recommended that these tanks be hot refueled.

GROUND REFUELING PANEL

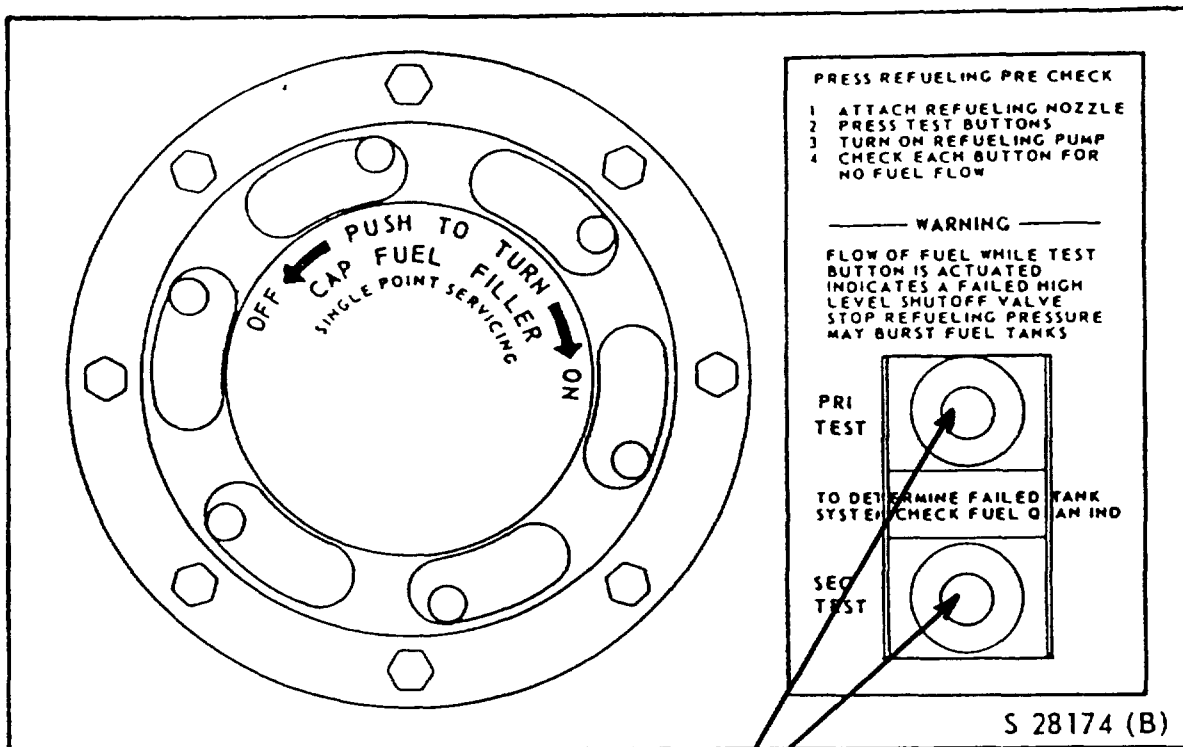

PRECHECK SWITCHES

MIL-HDBK-844(AS)

AIRCRAFT: H-3

PERSONNEL DANGER ZONES

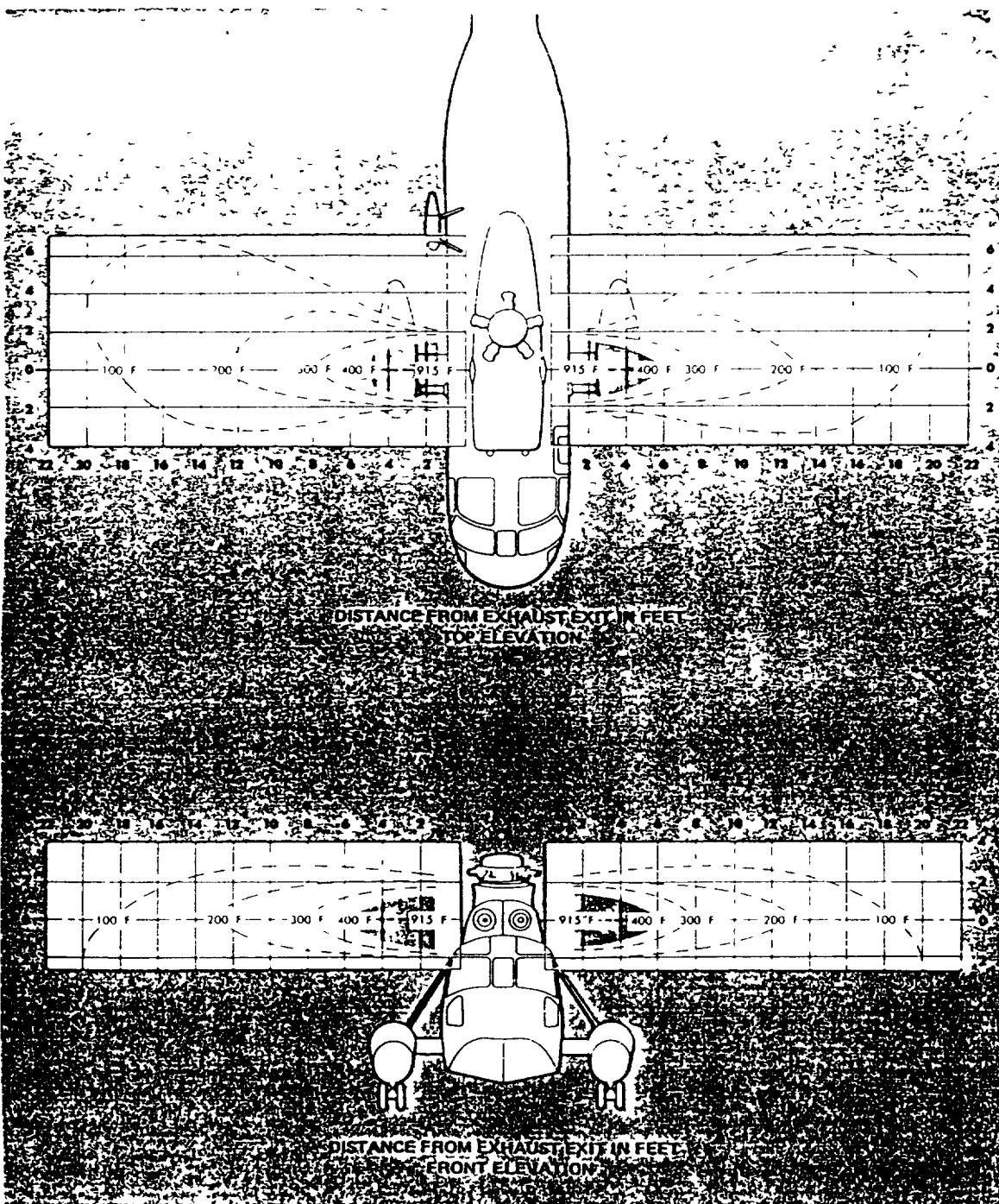

AIRCRAFT: H-46

AIRCRAFT CONFIGURATION

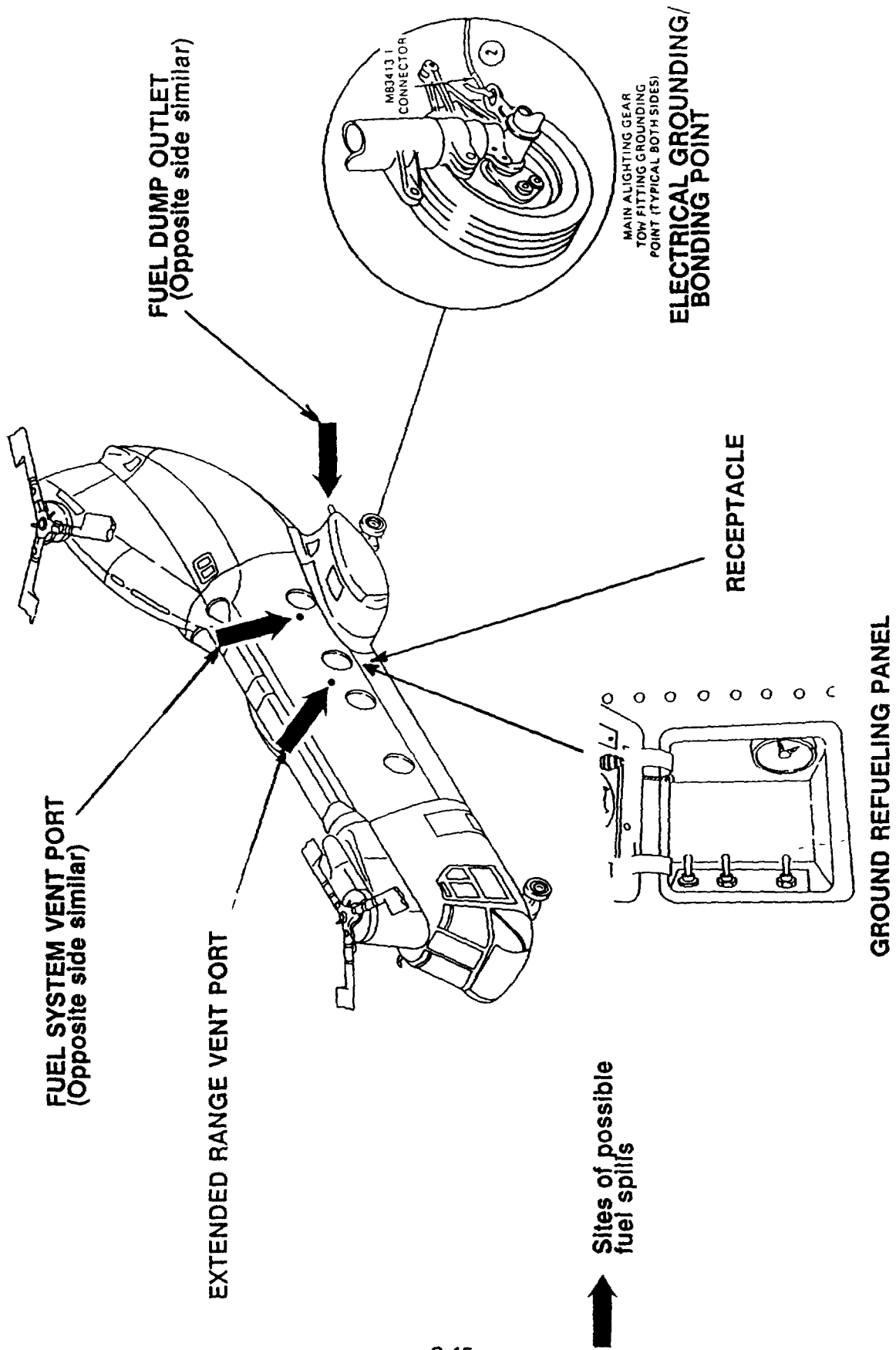

MIL-HDBK-844(AS)

AIRCRAFT: H-46

TABLE OF FUEL CAPACITIES

Tank		Gallons
Stubwing	Left	190*
	Right	190*
Total Internal		380
Extended Range Tanks (Each) Maximum of Three		250

* Certain aircraft have special extended capacity in their stubwing tanks - 330 gal each

AIRCRAFT CHARACTERISTICS

Aircraft Dimensions	Aircraft Weight
Fuselage Width 14 ft 9 in	Maximum Gross Weight 23,000 lbs
Length 84 ft 4 in	Maximum Footprint 170 psi
Height 18 ft 4 in	

H-46 REFUELING PROCEDURES

The following procedures cover only the refueling procedures which are unique to the H-46 aircraft, primarily the operation of the "pre-check" system. In addition to these specialized procedures, the applicable, basic refueling procedures contained in chapter 6 or 12 of the Aircraft Refueling NATOPS Manual, NAVAIR 00-80T-109, must be followed.

1. Open Ground Refueling Panel access door.
2. Remove receptacle cap, attach refueling nozzle, open nozzle to the fully open and locked position, and initiate fuel flow.

venting is indicated, cease fueling operation immediately.

3. Locate the Precheck system valve test switches on the ground refueling panel. Hold left "VALV CONT" switch to "PRI CLOSE" and the right "VALV CONT" switch to "SEC CLOSE". Fuel flow into the aircraft should stop within a few seconds.
4. Release switches and fuel flow should resume.
5. Repeat the precheck process in step three above, this time holding the left "VALV CONT" switch to "PRI CLOSE".

WARNING

- Ensure that air is venting from "FUEL SYSTEM VENTS". If no

CAUTION

- If fuel flow does not stop step 3 or 5

AIRCRAFT: H-46

above, discontinue hot refueling operation immediately. System failure must be investigated and resolved before hot refueling can be accomplished.

6. Release switches and refuel aircraft until fuel flow into the aircraft stops and the fuel quantity gage on the ground refueling panel indicates the tanks are full.

SPECIAL NOTES AIRCRAFT FUEL SYSTEM

1. Under normal conditions, all air being displaced by fuel in the tanks exits the aircraft through the common "Fuel System Vent Port" which is located on each side of aircraft.
2. If any high level shut-off valves fail to operate correctly, fuel may spill from one of the "Fuel System Vent Port". In addition, the fuel tanks, which are located in the Stubwings, may rupture and spill fuel.

GROUND REFUELING PANEL

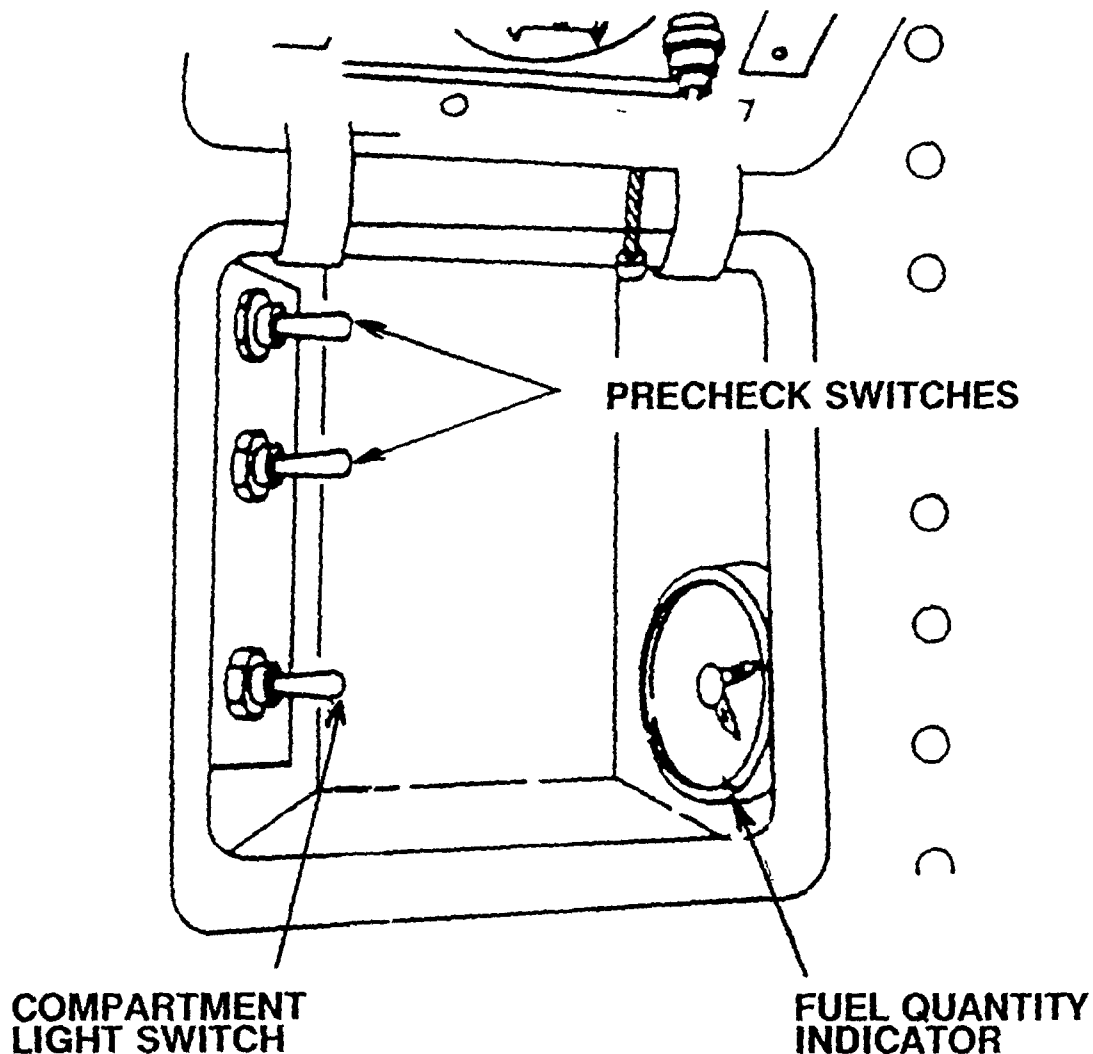

MIL-HDBK-844(AS)

AIRCRAFT: H-46

PERSONNEL DANGER ZONES

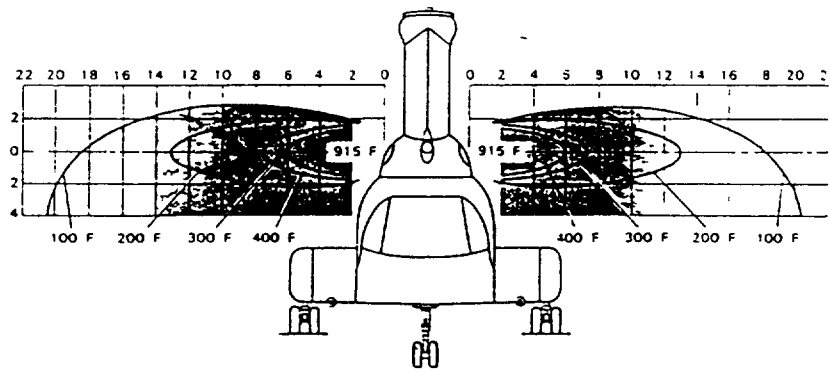
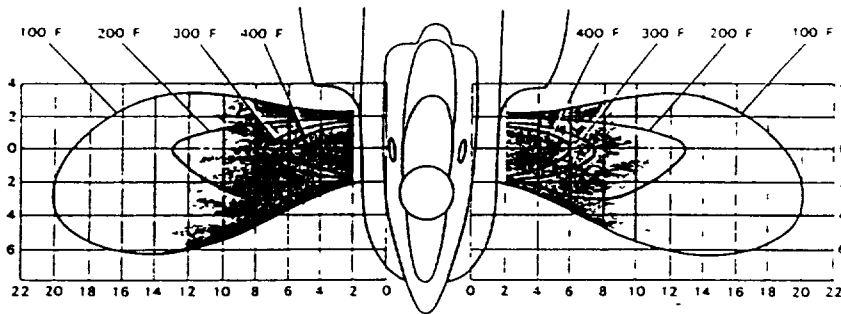

ENGINE EXHAUSE WAKE PROFILE - FEET

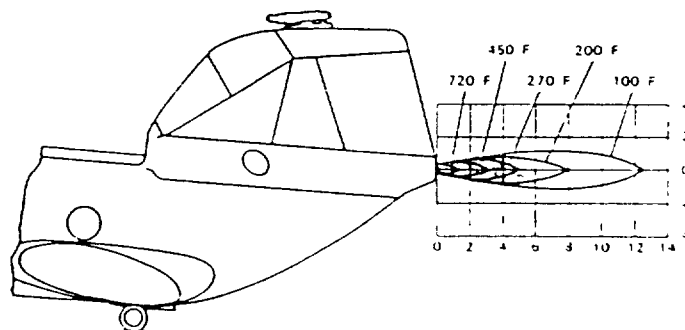

APU EXHAUST WAKE PROFILE - FEET

AIRCRAFT: H-53

AIRCRAFT CONFIGURATION

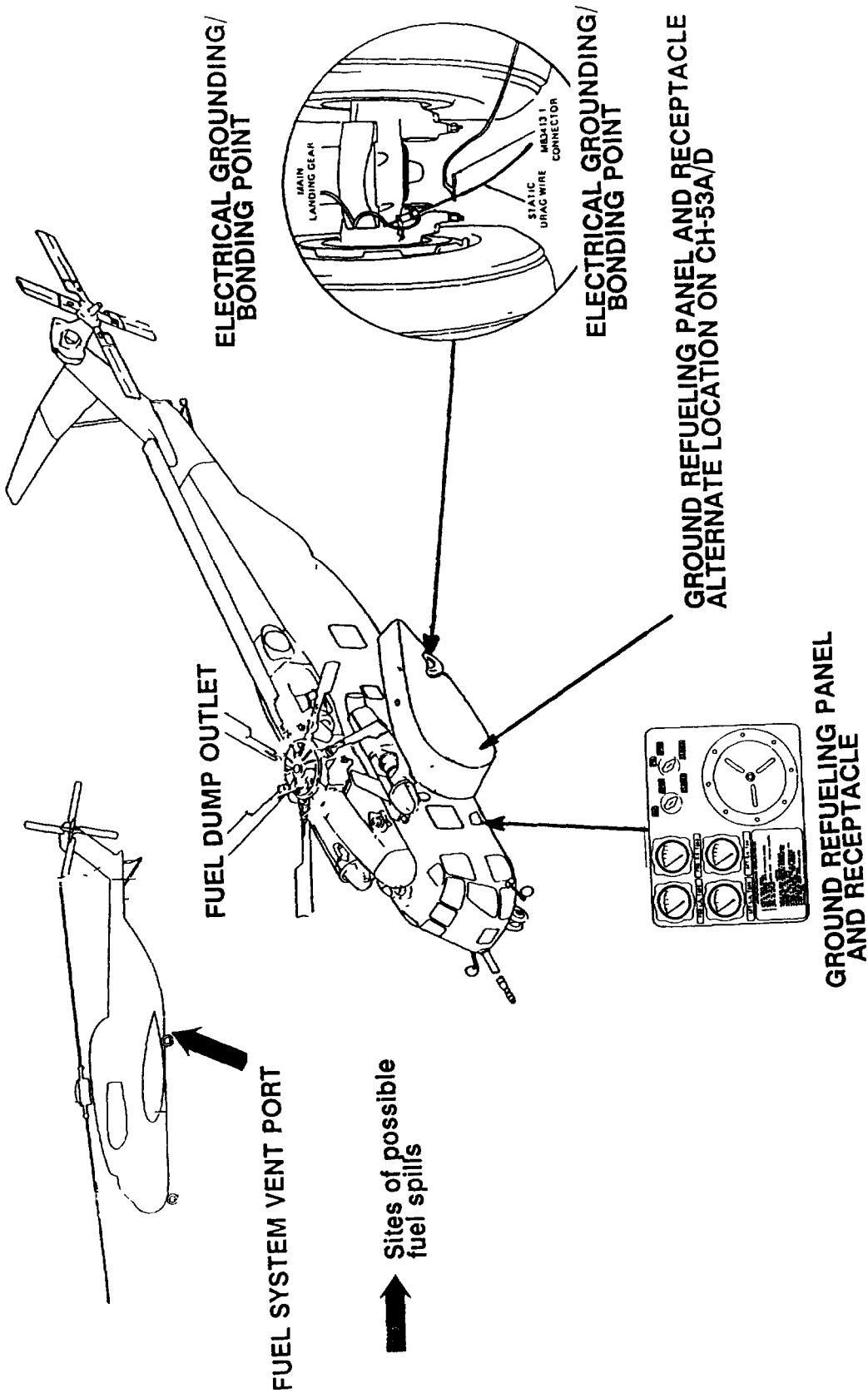

MIL-HDBK-844(AS)

AIRCRAFT: H-53

TABLES OF FUEL CAPACITIES

MH-53E

Tank		Gallons
Internal	No. 1	914.6
	No. 2	1,383.2
	No. 3	914.6
	Total	3,212.4

CH-53E

Tank		Gallons
Internal	No. 1	300
	No. 2	377
	No. 3	300
	Total	977
External Aux Tanks (Each)		650
Total	With 2 Aux Tanks	2,277

CH-53A/D

Tank		Gallons
Internal	Left	319
	Right	319
	Total	638
External Aux Tanks (Each)		650
Total	With 2 Aux Tanks	1,938

AIRCRAFT: H-53

AIRCRAFT CHARACTERISTICS

CH-53E, MH-53E

Aircraft Dimensions		Aircraft Weight	
Fuselage Width	14 ft (With Aux Tanks)	Maximum Gross Weight 73,500 lbs	
Length	99 ft 0.5 in	Maximum Footprint 135 psi	
Height	28 ft 0.5 in		

CH-53A/D

Aircraft Dimensions		Aircraft Weight	
Fuselage Width	24 ft (With Aux Tanks)	Maximum Gross Weight 42,000 lbs	
Length	88 ft 6 in	Maximum Footprint 135 psi	
Height	24 ft 11 in		

H-53 REFUELING PROCEDURES

The following procedures cover only the refueling procedures which are unique to the H-53 aircraft, primarily the operation of the "pre-check" system. In addition to these specialized procedures, the applicable, basic refueling procedures contained in chapter 6 or 12 of the Aircraft Refueling NATOPS Manual, NAVAIR 00-80T-109, must be followed.

1. Open Ground Refueling Panel access door.
2. Remove receptacle cap, attach refueling nozzle, open nozzle to the fully open and locked position, and initiate fuel flow.
3. Exercise the Precheck system. On A and D models, simultaneously turn both precheck valves on the Ground Refueling Panel to "CLOSED" position. Fuel flow into the aircraft should stop within 10 seconds. On the CH-53E and MH-53E, turn the precheck valve labeled "PRI" to the "CLOSED" position and observe that fuel flow stops, then return the valve to the "OPEN" position. Repeat the last step

this time turning the precheck valve labeled "SEC" to the "CLOSED" position.

WARNING

- Flow of fuel while precheck valve(s) are in closed position(s) indicates a failed shutoff valve. Stop refueling immediately. System failure must be investigated and resolved before hot refueling can be accomplished.
4. Place precheck valves on Ground Refueling Panel in the "OPEN" positions and refuel aircraft
 5. Monitor the "Tank Pressure Indicators" on the Ground Refueling Panel.

MIL-HDBK-844(AS)

AIRCRAFT: H-53

CAUTION

SPECIAL NOTES AIRCRAFT FUEL SYSTEM

- If any tank pressure indicator rises above 1.5 psi, stop refueling immediately. Blockage in vent system must be investigated and corrected prior to refueling.
7. Continue fueling until fuel flow stops automatically.

1. Under normal conditions, all air being displaced by fuel in the tanks exits the aircraft through the common "Fuel System Vent Port" which is located on the bottom of the aircraft's fuselage.

2. If any high level shut-off valves fail to operate correctly, fuel may spill from one of the "Fuel System Vent Port". In addition, the fuel tanks may rupture and spill fuel.

3. The A and D model aircraft can be fitted with internal range extension tanks. Special procedures must be followed by the aircrew in order to refuel these tanks.

GROUND REFUELING PANEL

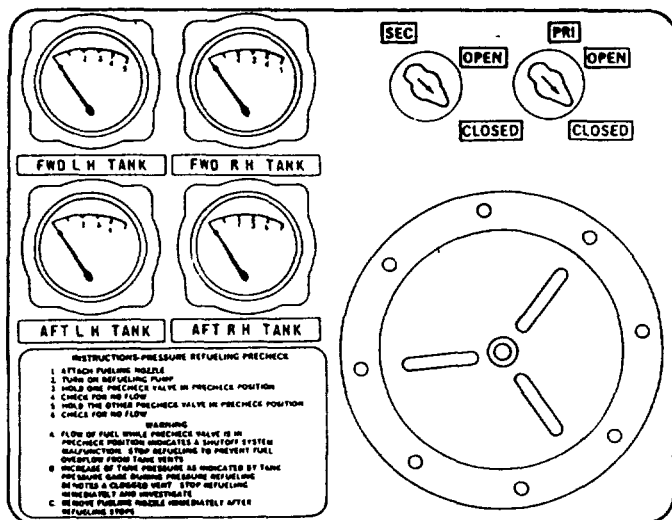

**GROUND REFUELING PANEL
CH-53E and MH-53E**

L.H. TANK
PRECHECK
VALVE

R.H. TANK
PRECHECK
VALVE

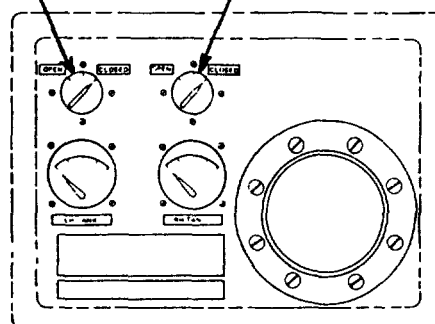

**GROUND REFUELING PANEL
CH-53A/D**

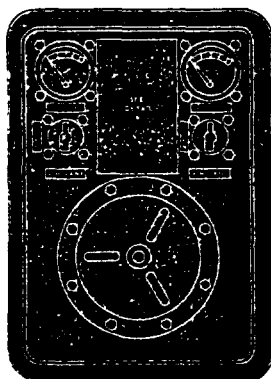

**ALTERNATE GROUND REFUELING PANEL
CH-53A/D**

AIRCRAFT: H-53

PERSONNEL DANGER ZONES

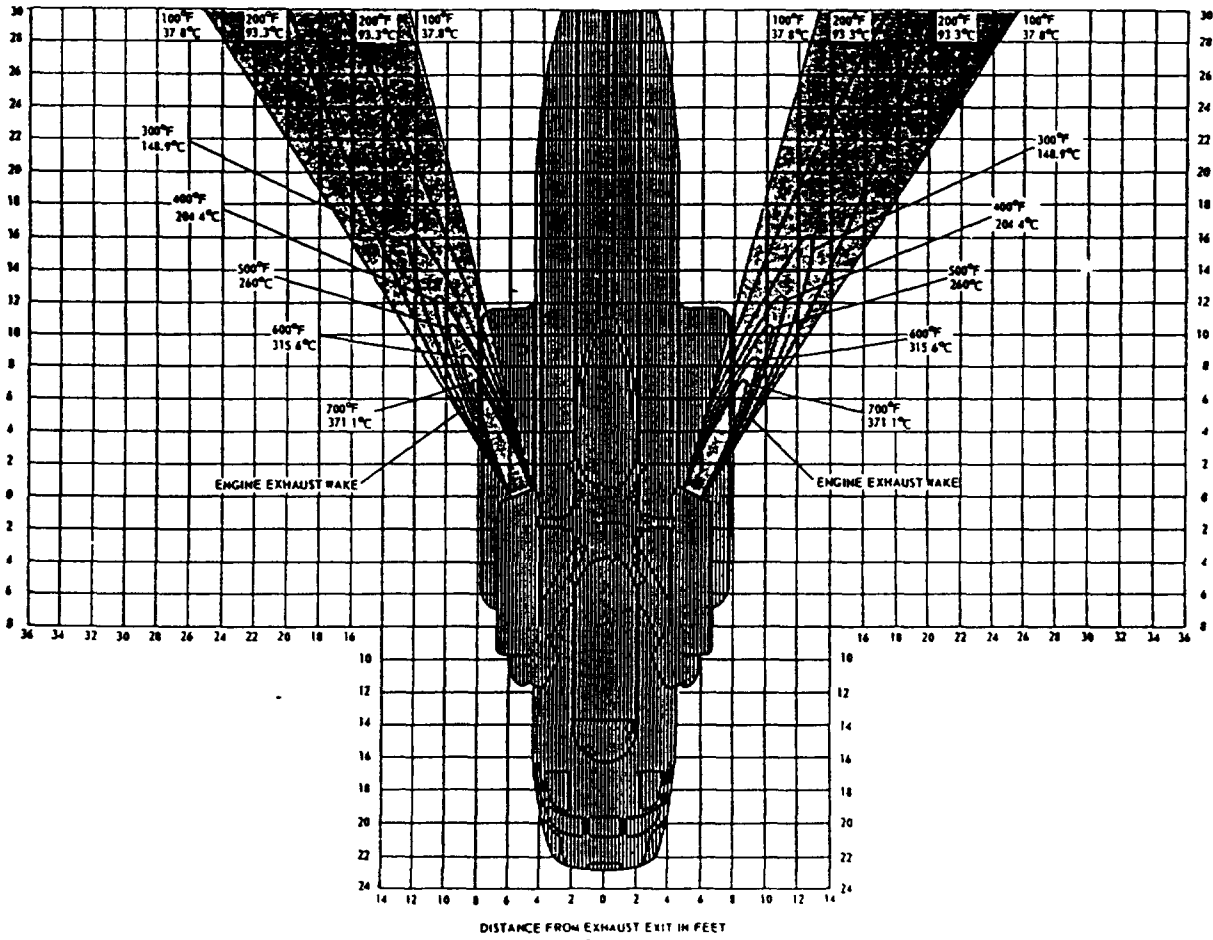

MIL-HDBK-844(AS)

AIRCRAFT: SH-60 AIRCRAFT CONFIGURATION

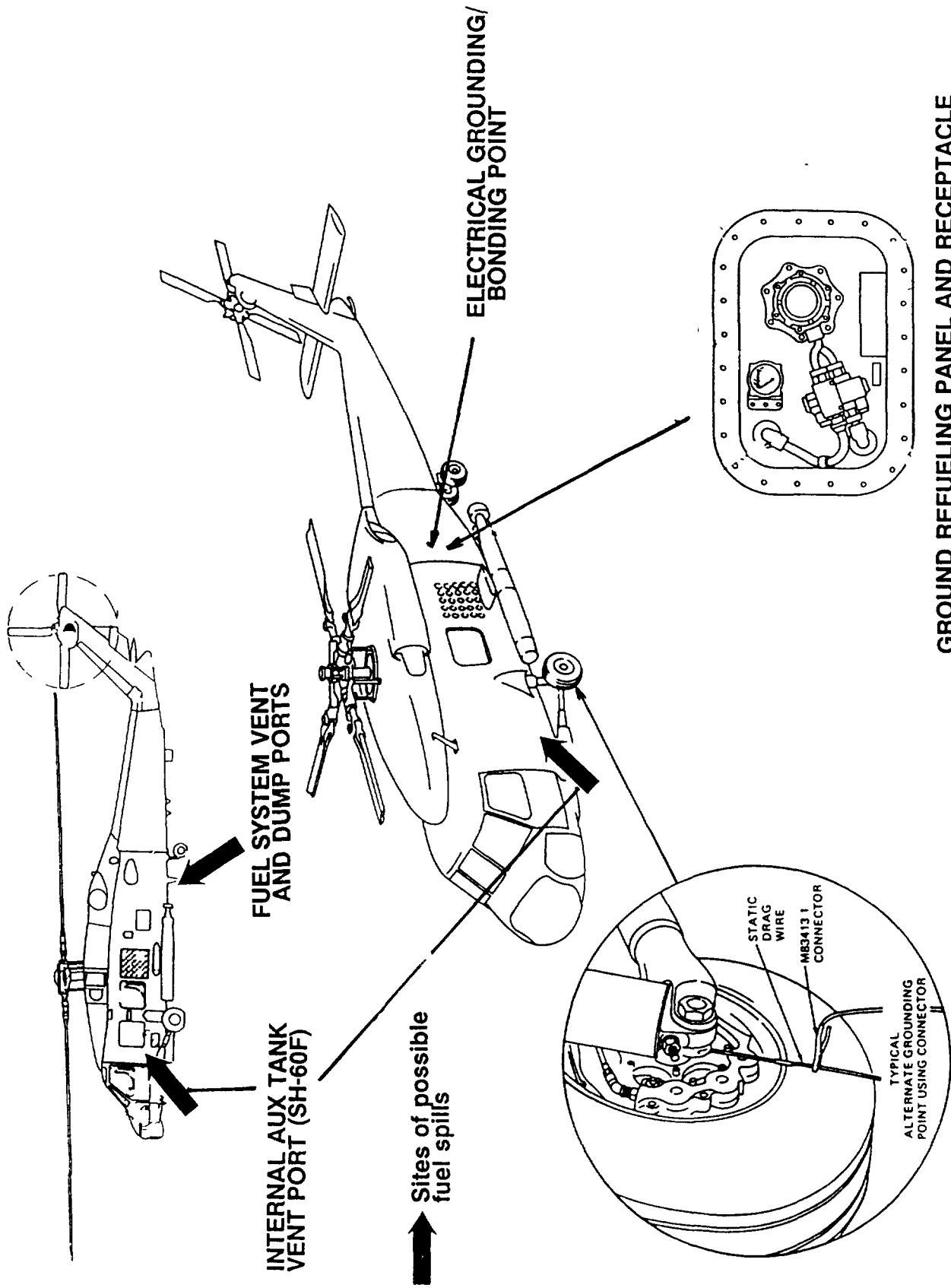

AIRCRAFT: SH-60

TABLE OF FUEL CAPACITIES

Tank		Gallons
Main		590
External Aux	Left	120
	Right	120
Internal Aux (SH-60F only)		105
Total Main + Aux		830
Total SH-60		935

AIRCRAFT CHARACTERISTICS

Aircraft Dimensions	Aircraft Weight
Fuselage Width 7 ft 9 in (With Aux Tanks)	Maximum Gross Weight 22,000 lbs
Length 64 ft 10 in	Maximum Footprint 90 psi
Height 17 ft	

SH-60 REFUELING PROCEDURES

The following procedures cover only the refueling procedures which are unique to the SH-60 aircraft, primarily the operation of the "pre-check" system. In addition to these specialized procedures, the applicable, basic refueling procedures contained in chapter 6 or 12 of the Aircraft Refueling NATOPS Manual, NAVAIR 00-80T-109, must be followed.

1. Open Ground Refueling Panel access door.
2. Remove receptacle cap, attach refueling nozzle, open nozzle to the fully open and locked position, and initiate fuel flow.
3. Monitor the "Tank Pressure indicator" on the Ground Refueling Panel.

CAUTION

- If tank pressure indicator enters the red band, stop refueling immediately. Blockage in vent system must be investigated and corrected prior to refueling.
- 4 Hold the "OUTBOARD PRECHECK VALVE" in the "PRECHECK" position. Fuel flow should stop within 6 seconds.
 5. Release the "OUTBOARD PRECHECK VALVE" and resume fuel flow.
 6. Repeat the precheck process in step four above, this time holding the "INBOARD PRECHECK VALVE"

MIL-HDBK-844(AS)

AIRCRAFT: SH-60

in the "PRECHECK" position. Again fuel flow should stop within 6 seconds.

SPECIAL NOTES
AIRCRAFT FUEL SYSTEM

CAUTION

- If fuel flow does not stop step 4 or 6 above, discontinue hot refueling operation immediately. System failure must be investigated and resolved before hot refueling can be accomplished.
- 6 Release precheck valves and refuel aircraft until fuel flow into the aircraft automatically stops indicating the aircraft's tanks are full

1. Under normal conditions, all air being displaced by fuel in the tanks exits the aircraft through the common "Fuel System Vent Port" which is located on the bottom of the aircraft's fuselage. The SH-60F aircraft has an internal auxillary tank which vents to an opening on the lower port side of the aircraft near the front. Each external auxillary tank has a vent opening on its bottom approximately in the center.

2. If any high level shut-off valves fail to operate correctly, the tanks may rupture and/or fuel may spill from one of the Fuel System Vent Port".

3. The SH-60F aircraft has a second Tank Pressure Indicator which displays the pressure in the Internal Auxillary Tank.

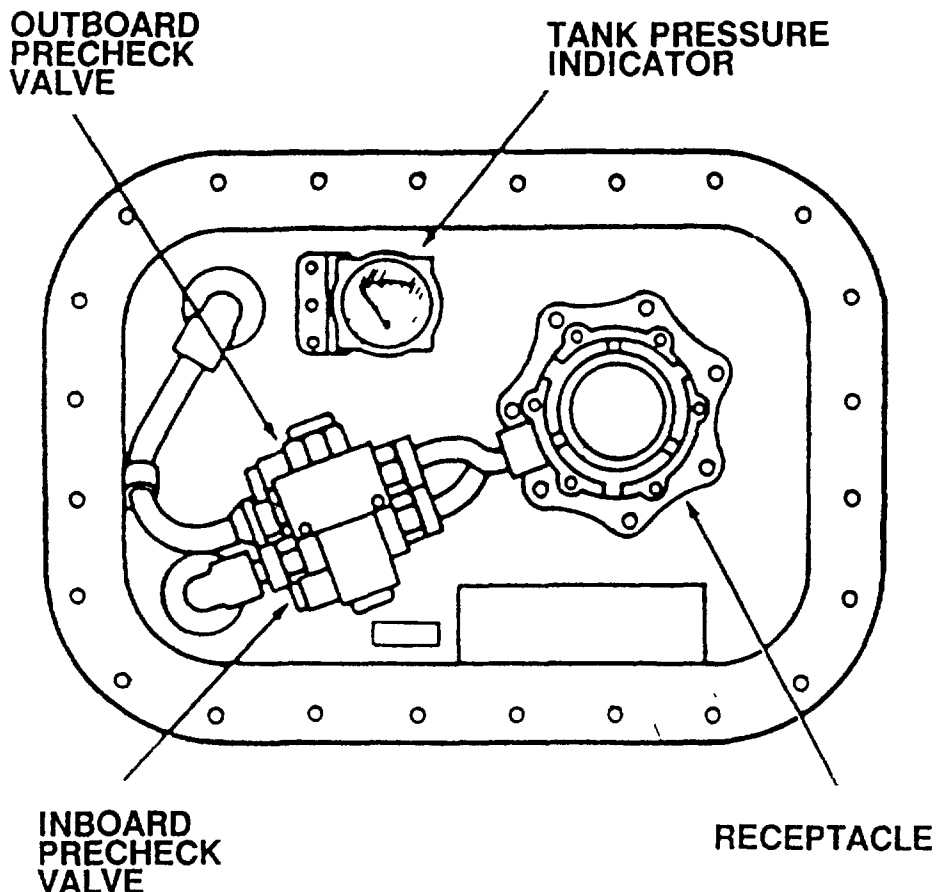
GROUND REFUELING PANEL

AIRCRAFT: SH-60

PERSONNEL DANGER ZONES

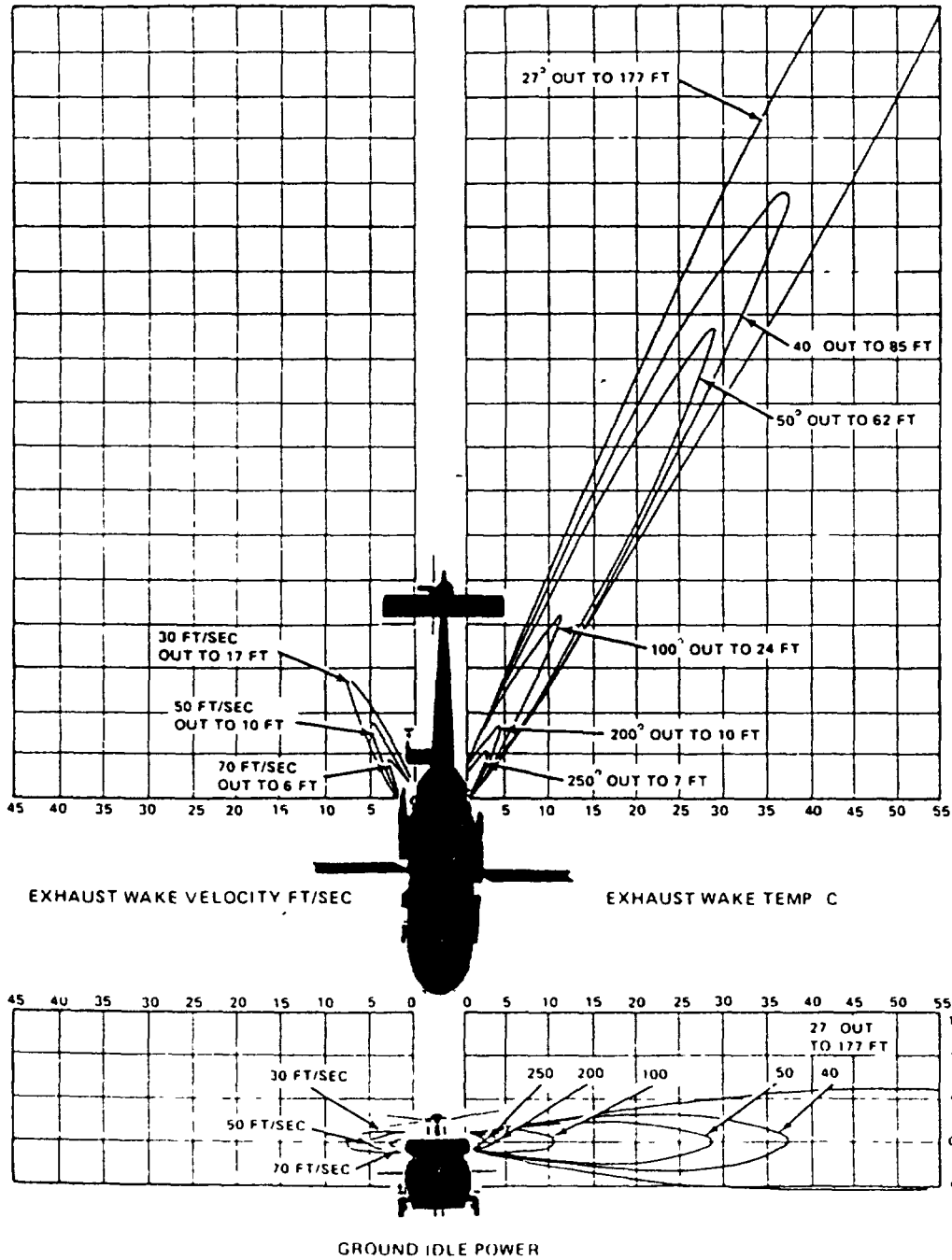

MIL-HDBK-844(AS)

(This page intentionally left blank).

APPENDIX D

GLOSSARY

AFFF

The acronym for Aqueous Film forming Foam, the department of Defense standard firefighting agent for flammable and combustible liquid fires.

Adsorption

A separation method where one component is concentrated on the surface of a porous solid. Surfactants (surface active agents) are separated from jet fuel by adsorption on clay.

Ambient Temperature

The air temperature surrounding a specific area.

API Gravity

The petroleum industry's scale and method of measuring density of petroleum products.

Aviation Gasoline (avgas)

Specially blended gasolines used to power reciprocating piston aircraft engines.

Clay Treater

A treating unit that utilizes a special clay (Fuller's earth) to remove surfactants from turbine fuel.

CMC

Commandant of the Marine Corps.

CNATRA

Chief of Naval Air Training.

CNO

Chief of Naval Operations.

Coalescence

The property of a filter cartridge to bring together very fine droplets of free and entrained water to form large droplets which are heavy enough to fall to the bottom of the filter/separator vessel.

Contaminants

Substances either foreign or native which may be present in fuel that detract from its performance.

Cowling

Removable covering around engine sections.

Cyclone Separator

A device that used the principal of centrifugal force to cause the contaminate in a fuel to settle to the bottom of the vessel without the use of filter media.

Density

The amount of mass (weight) in a unit volume of a material.

Differential Pressure (Delta P)

The measured difference in pressure between any two points, generally at the inlet and outlet of a filter or a filter/separator.

Disarming Action

As applied to filter/separators, the rendering of the elements incapable of performing their designed functions; e.g., coalescer elements incapable of coalescing water and separator elements incapable of separating water from fuel.

Dissolved Water

Water which is in solution in the fuel. This water is not free water and cannot be removed by conventional means.

Eductor

1. A device placed in a hose line to proportion liquid foam or wetting agents into the fire stream.

2. An ejector that siphons water by creating a vacuum from the velocity of water passing through it.

MIL-HDBK-844(AS)**Effluent**

Stream of fluid at the outlet of a filter or filter/separator. This is the opposite of influent.

Empennage

Aircraft tail assembly including stabilizers, elevators, rudders, etc.

Emulsion

A dispersion of two dissimilar immiscible droplets in the continuous phase.

Entrained Water

Small droplets of free water in suspension which may make fuel appear hazy.

EOD

Explosive ordnance disposal

ETA

Estimated time of arrival.

Exhaust

The part of the engine through which the exhaust gases are ejected.

Filter

A device to remove solid contaminants from fuel.

Filter Membrane (Millipore) Test

A standard test in which fuel is passed through a small filter membrane housed in a plastic holder. The cleanliness of the fuel can be determined by examining the membrane.

Filter/Separator

A mechanical device used to remove entrained particulate contaminants and free water from a fuel.

Fin

A fixed or adjustable airfoil for directional stability, such as a tail fin or a skid fin. A common name given the vertical stabilizer.

Fixed Base Operator (FBO)

Common title for aviation fuel dealer at the airport.

Flaps

A movable airfoil attached to the trailing edge of the wing which improves the aerodynamic performance of the aircraft during takeoffs and landings.

Flash Point

The lowest fuel temperature at which the vapor above the fuel will ignite.

Floating Suction

A floating device used in a tank for drawing product from the upper level of the fuel.

FMFPAC/LANT

Fleet Marine Force, Pacific or Atlantic

Free Water

Water in the fuel other than dissolved water. Free water may be in the form of droplets or haze suspended in the fuel (entrained water) and/or a water layer at the bottom of the container holding the fuel. Free water may also exist in the form of an emulsion which may be so finely dispersed as to be invisible to the naked eye.

Freezing Point (Fuel)

The lowest fuel temperature at which there are no crystals.

Halogenated agent

An extinguishing agent composed of hydrocarbons in which one or more hydrogen atoms have been replaced by halogen atoms; the common halogen elements used are fluorine, chlorine, bromine, and iodine.

Hazardous material

Any substance which, by reason of being explosive, flammable, poisonous, corrosive, oxidizing, irritating, or otherwise harmful, is likely to cause death or injury.

Landing gear

The understructure which supports the weight of an aircraft when in contact with land. It usually contains a mechanism for reducing the shock of landing (also called undercarriage).

Hydrophilic

Water accepting or water wettable.

Immiscible

Liquids which are mutually insoluble. This is the opposite of miscible.

Influent

Stream of fluid at the inlet of a filter or filter/separator. This is the opposite of effluent.

Loungers

The principal longitudinal structural members of the fuselage.

Micron (micrometer)

A unit of linear measurement. One micron is equal to .000029 in. and approximately 25,400 microns equals 1 in. For example, the average human hair is about 100 microns in diameter.

Miscible

Liquids which are mutually soluble. This is the opposite of immiscible.

Monitor

A device which shows or gives warning of improper performance (noun); or to test or check performance on a continuing basis (verb).

Nacelle

The enclosed streamlined housing for a powerplant. A nacelle is usually shorter than a fuselage and does not carry the tail unit.

NATSF

Naval Air Technical Services Facility.

NAVAIR

Naval Air Systems Command.

NAVFAC

Naval Facilities Engineering Command.

NAVSEA

Naval Sea Systems Command.

NAVSUP

Naval Supply Systems Command.

NFPA

National Fire Protection Association.

OPNAVINST

Chief of Naval Operations Instruction.

Oxidizer

1. A substance that readily gives up oxygen without requiring an equivalent of another element in return.

2. A substance that contains an atom or atomic group that gains electrons, such as oxygen, ozone, chlorine, hydrogen peroxide, nitric acid, metal oxides, chlorates,, and permanganates (also called oxidizing agent).

Particulate Matter

Solid contaminants (e.g., dirt, rust, scale, sand, etc.) sometimes found in fuel.

Pod

The enclosed streamlined housing around the jet engine.

Prefilter

A filter which has a high dirt-holding capacity which is installed up-stream of other filtration equipment.

Pressure Drop

See Differential Pressure above

Pylon, nacelle strut

The structure that attaches a jet engine to the wing.

Relative Density (Specific Gravity)

In fuel, this is the ratio of weight of any volume of fuel to the weight of an equal volume of water.

Rudder

The upright movable part of the tail assembly which controls the direction(yaw) of the aircraft.

Settling Time

The time allowed for water or dirt entrained in the fuel to drop to the bottom of the storage tank.

MIL-HDBK-844(AS)

Slat

A movable auxiliary airfoil, the primary function of which is to increase the stability of the aircraft. Slats are found on the leading edge of the wing

Specific Gravity

See Relative Density above

Stabilizer

Any airfoil the primary function of which is to increase the stability of the aircraft. The term stabilizer is most commonly used in reference to the fixed horizontal tail surface of the aircraft.

Sump

A low point in a system for collection and removal of water and solid contaminants

Surfactant

Any wetting agent.

Surfactants (Surface Active Agents)

Chemical substances which make it difficult to separate fuel and water and that disarm filter/separators.

T.A.U.

Twin agent fire extinguisher

T.O.

Technical order.

Thief (Sump) Pump

A small pump having a suction line which extends to the low point of a tank for the purpose of drawing off water which may have accumulated.

Turbine Fuel

A group of various kerosines or wide-cut types of fuels used to power aircraft turbine engines.

Water Slug

A large amount of free water.

INDEX

- B**
- bonding 6-5, 6-6, 6-7
- C**
- CCFD 5-1, 5-3
 CFD 5-1, 5-2, 5-3
 clothing 6-13
- D**
- defueling 6-1, 6-4, 6-5, 6-7, 6-13
 deterioration use limits 3-4, 4-2
- E**
- earthing 6-7
 extinguishment 6-7, 6-8, 6-10
- F**
- filter/separator 4-3, 4-4, 6-5, 6-13,
 D-1, D-2, D-3
 flame spread rate 6-2, 6-3
 fsii 3-2, 3-3, 4-2, 4-3, 4-4, 5-1, 5-4, 6-13
 fuel system icing inhibitor 3-2, 4-2,
 5-1, 5-4, 6-13
 FWD 5-1, 5-3
- G**
- grounding 5-2, 5-3, 6-7
- H**
- halon 6-8, 6-9
 health hazards 6-10, 6-13
 hoses 4-2
 hot refueling 2-1, C-4
 hydrant 4-4
- I**
- ignition 6-1, 6-4, 6-5, 6-7, 6-8
- M**
- meter 3-4, 4-1, 5-1, 5-2, 5-4
- N**
- nozzle 4-1, 6-6, 6-8, 6-9, 6-10, C-4
- P**
- particulate 4-1, 4-2, 4-5,
 5-1, 5-2, 6-16, D-2, D-3
 PKP 6-8, 6-10
- R**
- relaxation chambers 3-2, 6-6
- S**
- sampling 2-2, 4-5, 5-2, 5-3, 5-4
 spill 2-1, 6-10, C-4
 static electricity 6-4
- T**
- tank car 2-2
 tank truck 2-2
 testing 1-1, 3-4, 4-3, 4-5, 5-2,
 5-4, 6-2, B-1, B-2
 testing equipment
 contaminated fuel detector (CFD) 5-1
 conductivity meter 3-4, 5-4
 free water detector 5-3
 fuel system icing inhibitor (FSII) test kit 5-4
 truck 2-2, 4-3, 4-4
- V**
- vapor pressure 4-5, 6-1, 6-2, 6-9
- W**
- water 2-2, 3-1, 3-2, 3-3, 3-4, 3-5,
 4-1, 4-2, 4-3, 4-4, 4-5, 5-1, 5-3, 5-4,
 6-5, 6-6, 6-8, 6-10, 6-13, 6-16,
 6-17, D-1, D-2, D-3, D-4

MIL-HDBK-844(AS)

CONCLUDING MATERIAL

**Custodian:
Navy - AS**

**Preparing activity:
Navy - AS
(Project 9130-N001)**

STANDARDIZATION DOCUMENT IMPROVEMENT PROPOSAL

INSTRUCTIONS

1. The preparing activity must complete blocks 1, 2, 3, and 8. In block 1, both the document number and revision letter should be given.
2. The submitter of this form must complete blocks 4, 5, 6, and 7.
3. The preparing activity must provide a reply within 30 days from receipt of the form.

NOTE: This form may not be used to request copies of documents, nor to request waivers, or clarification of requirements on current contracts. Comments submitted on this form do not constitute or imply authorization to waive any portion of the referenced document(s) or to amend contractual requirements

I RECOMMEND A CHANGE:

1. DOCUMENT NUMBER
MIL-HDBK-844(AS)

2. DOCUMENT DATE (YYMMDD)
20 October 1992

3. DOCUMENT TITLE
AIRCRAFT REFUELING HANDBOOK

4. NATURE OF CHANGE (Identify paragraph number and include proposed rewrite, if possible. Attach extra sheets as needed)

5. REASON FOR RECOMMENDATION

6. SUBMITTER

a. NAME (Last, First, Middle Initial)

b. ORGANIZATION

c. ADDRESS (Include Zip Code)

d. TELEPHONE (Include Area Code)

7. DATE SUBMITTED (YYMMDD)

(1) Commercial
(2) AUTOVON
(if applicable)

8. PREPARING ACTIVITY

a. NAME

b. TELEPHONE (Include Area Code)

(2) AUTOVON
222-2653

Naval Air Systems Command AIR-5363C

(1) Commercial
202-692-2653

c. ADDRESS (Include Zip Code)

Naval Air Systems Command
AIR-5363C
Washington, DC 20361-5360

IF YOU DO NOT RECEIVE A REPLY WITHIN 45 DAYS, CONTACT:
Defense Quality and Standardization Office
5203 Leesburg Pike, Suite 1403, Falls Church, VA 22041-3466
Telephone (703) 756-2340 AUTOVON 289-2340