

MIL-HDBK-216
4 January 1962

MILITARY STANDARDIZATION HANDBOOK

**RF TRANSMISSION LINES
AND FITTINGS**



FSC 5935
FSC 5908
FSC 6145

MIL-HDBK-216
NOTICE 1
18 May 1965

TO ALL ACTIVITIES

1. The following sections of MIL-HDBK-216 have been revised and supersede the sections listed below:

NEW SECTION	DATE	SUPERSEDED SECTION	DATE
Section 1A	18 May 1965	Section 1	4 January 1962
Section 2A	18 May 1965	Section 2	4 January 1962
Section 3A	18 May 1965	Section 3	4 January 1962

2. Retain this Notice and insert before the table of contents.

MIL-HDBK-216
 NOTICE 2
 20 July 1965

MILITARY HANDBOOK

R.F. TRANSMISSION LINES AND FITTINGS

TO ALL ACTIVITIES:

1. The following section of MIL-HDBK-216 has been revised and supersedes the section listed below:

NEW SECTION	DATE	SUPERSEDED SECTION	DATE
Section 4A	20 July 1965	Section 4	4 January 1962

2. The following is a cumulative list of earlier changes:

NEW SECTION	DATE	SUPERSEDED SECTION	DATE
Section 1A	18 May 1965	Section 1	4 January 1962
Section 2A	18 May 1965	Section 2	4 January 1962
Section 3A	18 May 1965	Section 3	4 January 1962

3. Retain this Notice and insert before the table of contents.

4. Holder of MIL-HDBK-216 will verify that section changes indicated above have been entered and will destroy the previous notice. Activities which stock these notices for issue are warned that each notice, together with its appended revised sections, is in effect a separate publication to be retained until the Military Handbook is completely revised or cancelled.

FSC 5935

MIL-HDBK-216
 NOTICE 3
 7 April 1967

MILITARY HANDBOOK

R.F. TRANSMISSION LINES AND FITTINGS

TO ALL ACTIVITIES:

1. The following sections of MIL-HDBK-216 have been revised and supersedes the sections listed below:

NEW SECTIONS	DATE	SUPERSEDED SECTIONS	DATE
Section 5A	7 April 1967	Section 5	4 January 1962
Section 6A	7 April 1967	Section 6	4 January 1962
Section 7A	7 April 1967	Section 7	4 January 1962
Section 8A	7 April 1967	Section 8	4 January 1962
Section 9A	7 April 1967	Section 9	4 January 1962

2. The following is a cumulative list of earlier changes:

NEW SECTIONS	DATE	SUPERSEDED SECTIONS	DATE
Section 1A	18 May 1965	Section 1	4 January 1962
Section 2A	18 May 1965	Section 2	4 January 1962
Section 3A	18 May 1965	Section 3	4 January 1962
Section 4A	20 July 1965	Section 4	4 January 1962

3. Retain this Notice and insert before the table of contents.

4. Holders of MIL-HDBK-216 will verify that section changes have been entered and will destroy the previous notice (notice page only). The latest notice (notice page) will be retained as a check sheet. This issuance, together with appended sections, is a separate publication. Each notice is to be retained by stocking points until the Military Handbook is completely revised or cancelled.

Custodians:

Army - EL
 Navy - SH
 Air Force - 11

Preparing activity:

Navy - SH
 (Project MISC-0256-5
 thru -9)

Review activities:

Army - MI, MU, EL
 Navy - SH
 Air Force - 11

User activities:

Army -
 Navy - MC, AS, OS

MILITARY HANDBOOK

R. F. TRANSMISSION LINES AND FITTINGS

TO ALL ACTIVITIES:

1. The following pages of MIL-HDBK-216 have been revised and supersede the pages listed below:

NEW PAGE	DATE	SUPERSEDED PAGE	DATE
3. 15	10 June 1970	3. 15	18 May 1965
3. 16	18 May 1965	(Reprinted without change)	
3. 31	18 May 1965	(Reprinted without change)	
3. 32	10 June 1970	3. 32	18 May 1965

2. The following is a cumulative list of earlier changes.

NEW SECTION	DATE	SUPERSEDED SECTION	DATE
1A	18 May 1965	1	4 January 1962
2A	18 May 1965	2	4 January 1962
3A	18 May 1965	3	4 January 1962
4A	20 July 1965	4	4 January 1962
5A	7 April 1967	5	4 January 1962
6A	7 April 1967	6	4 January 1962
7A	7 April 1967	7	4 January 1962
8A	7 April 1967	8	4 January 1962
9A	7 April 1967	9	4 January 1962

3. Retain this Notice and insert before table of contents.

4. Holders of MIL-HDBK-216 will verify that page and section changes have been entered and will destroy the previous notice (notice page only). The latest notice (notice page) will be retained as a check sheet. This issuance, together with applicable pages, is a separate publication. Each notice is to be retained by stocking points until the Military Handbook is completely revised or canceled.

Custodians:

Army - EL
Navy - EC
Air Force - 85

Preparing activity:

Navy - EC

Agent:

DSA - ES

Review activities:

Army - MI, MU, EL
Navy - SH
Air Force - 11, 85
DSA - ES

(Project MISC-0572)

User activities:

Army -
Navy - MC, AS, OS
Air Force -

FSC MISC

MIL-HDBK-216
 NOTICE 5
 10 March 1972

MILITARY HANDBOOK

R.F. TRANSMISSION LINES AND FITTINGS

TO ALL ACTIVITIES:

1. The following new pages of MIL-HDBK-216 have been added:

NEW PAGE	DATE
2.10A1 thru 2.10A2	10 March 1972
2.26A2	10 March 1972
2.28A2	10 March 1972
3.2A1	10 March 1972
3.30A1 thru 3.30A4	10 March 1972
3.30B1 thru 3.30B3	10 March 1972
3.33A1 thru 3.33A4	10 March 1972
3.33B1 thru 3.33B4	10 March 1972
3.48A1 thru 3.48A4	10 March 1972

2. The following pages of MIL-HDBK-216 have been revised and supersede the pages listed below:

NEW PAGE	DATE	SUPERSEDED PAGE	DATE
2.19 thru 2.19A1	10 March 1972	2.19	18 May 1965
2.20 thru 2.20A1	10 March 1972	2.20	18 May 1965
2.21 thru 2.21A1	10 March 1972	2.21	18 May 1965
2.22 thru 2.22A1	10 March 1972	2.22	18 May 1965
2.23 thru 2.23A1	10 March 1972	2.23	18 May 1965
2.24 thru 2.24A1	10 March 1972	2.24	18 May 1965
2.25 thru 2.25A1	10 March 1972	2.25	18 May 1965
2.26 thru 2.26A1	10 March 1972	2.26	18 May 1965
2.27 thru 2.27A1	10 March 1972	2.27	18 May 1965
2.28 thru 2.28A1	10 March 1972	2.28	18 May 1965
3.34	10 March 1972	3.34	18 May 1965
7.7	10 March 1972	7.7	7 April 1967
7.8	10 March 1972	7.8	7 April 1967

3. The following is a cumulative list of earlier changes:

NEW PAGE	DATE	SUPERSEDED PAGE	DATE
3.15	10 June 1970	3.15	18 May 1965
3.16	18 May 1965	(Reprinted without change)	
3.31	18 May 1965	(Reprinted without change)	
3.32	10 June 1970	3.32	18 May 1965

FSC MISC

MIL-HDBK-216

NOTICE 5

10 March 1972

NEW SECTION	DATE	SUPERSEDED SECTION	DATE
1A	18 May 1965	1	4 January 1962
2A	18 May 1965	2	4 January 1962
3A	18 May 1965	3	4 January 1962
4A	20 July 1965	4	4 January 1962
5A	7 April 1967	5	4 January 1962
6A	7 April 1967	6	4 January 1962
7A	7 April 1967	7	4 January 1962
8A	7 April 1967	8	4 January 1962
9A	7 April 1967	9	4 January 1962

4. Retain this Notice and insert before table of contents.

5. Holders of MIL-HDBK-216 will verify that page and section changes have been entered and will destroy the previous notice (notice page only). The latest notice (notice page) will be retained as a check sheet. This issuance, together with applicable pages, is a separate publication. Each notice is to be retained by stocking points until the Military Handbook is completely revised or canceled.

Custodians:

Army - EL
Navy - EC
Air Force - 11

Preparing activity:

Navy - EC

Review activities:

Army - MI, MU, ME
Navy - SH, OS
Air Force - 11, 80
DSA - ES

(Project MISC-0745)

User activities:

Army -
Navy - MC, AS, SH
Air Force -

MIL-HDBK-216
 NOTICE 6
 13 November 1974

MILITARY HANDBOOK

R.F. TRANSMISSION LINES AND FITTINGS

TO ALL ACTIVITIES:

1. THE FOLLOWING SECTION OF MIL-HDBK-216 HAS BEEN REVISED AND SUPERSEDED:

NEW SECTION	DATE	SUPERSEDED SECTION	DATE
4B	13 November 1974	4A	20 July 1965

2. RETAIN THIS NOTICE AND INSERT BEFORE TABLE OF CONTENTS.

3. Holders of MIL-HDBK-216 will verify that the section change indicated above has been entered. The notice page will be retained as a check sheet. This issuance, together with appended pages, is a separate publication. Each notice is to be retained by stocking points until the Military Handbook is completely revised or canceled.

Custodians:

Army - EL
 Navy - EC
 Air Force - 11

Preparing activity:

Navy - EC

Agent:

DSA - ES

Review activities:

Army - MI, MJ, ME
 Navy - SH, OS
 Air Force - 80, 85
 DSA - ES

(Project MISC-0987)

User activities:

Army -
 Navy - MC, AS, SH
 Air Force -

MIL-HDBK-216
NOTICE 7
12 June 1975

MILITARY HANDBOOK

R.F. TRANSMISSION LINES AND FITTINGS

TO ALL HOLDERS OF MIL-HDBK-216:

1. THE FOLLOWING PAGES OF MIL-HDBK-216 HAVE BEEN REVISED:

<u>NEW PAGE</u>	<u>DATE</u>	<u>SUPERSEDED PAGE</u>	<u>DATE</u>
iii	12 June 1975	iii	4 January 1962
iv	12 June 1975	- iv	4 January 1962
iva	12 June 1975		

2. THE FOLLOWING SECTION IS REVISED:

<u>NEW SECTION</u>	<u>DATE</u>	<u>SUPERSEDED SECTION</u>	<u>DATE</u>
6B	12 June 1975	6A	7 April 1967

3. RETAIN THIS NOTICE AND INSERT BEFORE TABLE OF CONTENTS.

4. Holders of MIL-HDBK-216 will verify that the section change indicated above has been entered. The notice page will be retained as a check sheet. This issuance, together with appended pages, is a separate publication. Each notice is to be retained by stocking points until the Military Handbook is completely revised or canceled.

Custodians:

Army - EL
Navy - EC
Air Force - 11

Review activities:

Army - MI, MU, NE
Navy - SH, OS
Air Force - 80, 85
DSA - ES

User activities:

Army -
Navy - AS, MC, SH
Air Force -

Preparing activity:
Navy - EC

Agent:

DSA - ES

(Project MISC-0981)

FSC MISC

MIL-HDBK-216
 NOTICE 8
 8 November 1976

MILITARY HANDBOOK

R.F. TRANSMISSION LINES AND FITTINGS

TO ALL HOLDERS OF MIL-HDBK-216:

1. THE FOLLOWING PAGES OF MIL-HDBK-216 HAVE BEEN REVISED:

<u>NEW PAGE</u>	<u>DATE</u>	<u>SUPERSEDED PAGE</u>	<u>DATE</u>
v	8 November 1976	iva	12 June 1975
vi	8 November 1976	v	4 January 1962

2. THE FOLLOWING SECTION IS REVISED:

<u>NEW SECTION</u>	<u>DATE</u>	<u>SUPERSEDED SECTION</u>	<u>DATE</u>
14A	8 November 1976	14	4 January 1962

3. RETAIN THIS NOTICE AND INSERT BEFORE TABLE OF CONTENTS.

4. Holders of MIL-HDBK-216 will verify that the section change indicated above has been entered. The notice page will be retained as a check sheet. This issuance, together with appended pages, is a separate publication. Each notice is to be retained by stocking points until the Military Handbook is completely revised or canceled.

Custodians:

Army - EL
 Navy - EC
 Air Force - 11

Preparing activity:
 Navy - EC

Agent:
 DSA - ES

Review activities:

Army - MI, AV, NE
 Navy - SH, OS
 Air Force - 99, 85
 DSA - ES

(Project MISC-OB24)

User activities:

Army - MU
 Navy - AS, MC
 Air Force -

FSC MISC

MIL-HDBK-216
 NOTICE 9
 28 April 1977

MILITARY HANDBOOK

R.F. TRANSMISSION LINES AND FITTINGS

TO ALL HOLDERS OF MIL-HDBK-216:

1. THE FOLLOWING PAGES OF MIL-HDBK-216 HAVE BEEN REVISED:

<u>NEW PAGE</u>	<u>DATE</u>	<u>SUPERSEDED PAGE</u>	<u>DATE</u>
v	28 April 1977	v	8 November 1976
vi	28 April 1977	vi	REPRINTED WITHOUT CHANGE

2. THE FOLLOWING SECTION IS REVISED:

<u>NEW SECTION</u>	<u>DATE</u>	<u>SUPERSEDED SECTION</u>	<u>DATE</u>
7B	28 April 1977	7A	7 April 1967

3. RETAIN THIS NOTICE AND INSERT BEFORE TABLE OF CONTENTS.

4. Holders of MIL-HDBK-216 will verify that the section change indicated above has been entered. The notice page will be retained as a check sheet. This issuance, together with appended pages, is a separate publication. Each notice is to be retained by stocking points until the Military Handbook is completely revised or canceled.

Custodians:

Army - EL
 Navy - EC
 Air Force - 11

Review activities:

Army - AV, MI, MU
 Navy - SH, OS
 Air Force - 85, 99
 DLA - ES

User activities:

Army -
 Navy - AS, MC, SH
 Air Force -

Preparing activity:

Navy - EC

Agent:

DLA - ES

(Project MISC-OB33)

FSC MISC

MIL-HDBK-216
 NOTICE 10
 11 March 1982

MILITARY HANDBOOK

R.F. TRANSMISSION LINES AND FITTINGS

TO ALL HOLDERS OF MIL-HDBK-216:

1. THE FOLLOWING PAGES OF MIL-HDBK-216 ARE BEING ISSUED TO CORRECT AN ERROR APPEARING IN NOTICE 5:

NEW PAGE	DATE
3.33B1	(Reprinted without change)
3.33B2	11 March 1982
3.33B3	(Reprinted without change)
3.33B4	(Reprinted without change)

2. RETAIN THIS NOTICE AND INSERT BEFORE TABLE OF CONTENTS.

3. Holders of MIL-HDBK-216 will verify that the section change indicated herein has been entered. This notice page will be retained as a check sheet. This issuance, together with appended pages, is a separate publication. Each notice is to be retained by stocking points until the Military Handbook is completely revised or canceled.

Custodians:

Army - CR
 Navy - EC
 Air Force - 85

Preparing activity
 Navy - EC

(Project MISC-0DB4)

Review activities:

Army - MI, AR
 Navy - SH, OS
 Air Force - 85, 99
 DLA - ES

User activities:

Navy - AS, MC, SH

Agent:

DLA - ES

MIL-HDEK-216
4 January 1962

DEFENSE SUPPLY AGENCY

WASHINGTON 25, D.C.

MIL-HDEK-216
RF Transmission Lines and Fittings
4 January 1962

1. This publication was approved 4 January 1962 for printing and inclusion in the Military standardization handbook series.
2. Every effort has been made to reflect the latest technical information on RF Transmission Lines and Fittings and manufacturing practices. It is the intent to review this handbook periodically to insure its completeness and currency. Users of this document are encouraged to report any errors discovered and any recommendations for changes or inclusions to the Standardization Division, Defense Supply Agency, Washington 25, D.C.

MIL-HDBK-216
4 January 1962

TABLE OF CONTENTS

	PAGE
SECTION 1 - INTRODUCTION	1.1
SECTION 2 - R. F. CABLES	
2-1 General Considerations	2.1
2-2 Tables	
Guide to Selection of Preferred RF Cables	2.4
Attenuation of Standard RF Cables vs Frequency	2.6
Attenuation of Standard RF Cable vs Frequency	2.8
Attenuation vs Frequency for Various Types of Transmission Lines	2.9
Power Rating (average watts input) of Preferred RF Cables vs Frequency in Megacycles	2.10
Attenuation vs Frequency	2.12
Power Input vs Frequency of Teflon Dielectric Cable	2.13
Solid Dielectric RF Cables, Flexible	2.14
Air Articulated Cables (Semi-Rigid)	2.23
SECTION 3 - R. F. CONNECTORS	
3-1 General Considerations	3.1
3-2 Tables	
Guide to Selection of Preferred RF Coaxial Connectors	3.4
Adapters (Between Series, Straight)	3.12
R. F. Cables vs Applicable R. F. Connectors	3.13
Adapter (Between Series)	3.19
Adapter (cable to rigid line)	3.24
A - Pressurized (requires male plug to connect cable to rigid line)	3.24
B - High-voltage, pressurized, cable to rigid line	3.26
C - Low-voltage, pressurized, cable to rigid line	3.26
D - High-voltage, nonpressurized, cable to rigid line	3.26
BN Connector Series	3.27
BNC Connector Series	3.28
Functional Diagram (BNC Series)	3.31
C Connector Series	3.32
Functional Diagram (C Series)	3.34
HN Connector Series	3.35
Functional Diagram (HN Series)	3.37
LC Connector Series	3.38
Small LC Connector Series	3.38
Large LC Connector Series	3.39
Adapters - small to large LC	3.40
LT Connector Series	3.41
Functional Diagram (LC Series)	3.42
LN Connector Series	3.43
N Connector Series	3.44
N Connector Series (50 ohms)	3.44
N Connector Series (70 ohms)	3.48
Functional Diagram (N Series)	3.49
Pulse Connectors, Ceramic-Insert Type	3.50
Small Ceramic-Insert Type	3.50
Large Ceramic-Insert Type	3.50
Pulse Connectors, Rubber-Insert Type	3.51
Triaxial Type Pulse Connectors	3.52
Functional Diagram (Pulse Series)	3.53
QDL Connector Series	3.54
QDS Connector Series	3.55

	PAGE
QL and QM Connector Series	3.56
Functional Diagram, QM and QL Series	3.57
SKL Connectors and Adapters	3.58
SM Connector Series	3.59
Type SM Connectors	3.60
TPS Connector Series	3.61
Twin Connector Series	3.62
Small twin, Nonweatherproof	3.62
Small twin, Weatherproof	3.62
Large twin, Nonweatherproof	3.62
Functional Diagram (Twin Series)	3.63
UNF Connector Series	3.64
UHF Connector Series (small coaxial)	3.64
UHF Connector Series (large coaxial)	3.65
Miscellaneous Connectors and Adapters	3.66
End Seals	3.69
Assembly Instructions for Series BN Connectors	3.70
Assembly Instructions for Series BNC Connectors	3.71
Assembly Instructions for Improved Series BNC Connectors	3.72
Assembly Instructions for Series C Connectors	3.73
Assembly Instructions for Series HN Connectors	3.74
Assembly Instructions for Series HN Connectors	3.75
UG-333/U and UG-334/U	
Assembly Instructions for Series HN Connectors UG-333A/U	3.76
and UG-334A/U	
Assembly Instructions for Series HN Connectors with	3.77
Captivated Contacts	
Assembly Instructions for Series LC Connectors	3.78
Assembly Instructions for Series LN Connectors	3.79
Assembly Instructions for Series LT Connectors	3.81
Assembly Instructions for Series N Connectors	3.82
Assembly Instructions for Improved Series N Connectors	3.83
Assembly Instructions for Series N Connectors with	3.84
Captivated Contacts	
Assembly Instructions for Ceramic Insert Pulse Connectors	3.85
Assembly Instructions for Rubber Insert Pulse Connectors	3.87
Assembly Instructions for RG-1372/U to RG-189/U Cable	3.89
Assembly Instructions for Series QL and QM Connectors	3.91
Assembly Instructions for Series SM Connectors	3.98
Assembly Instructions for Series UHF Connectors	3.100
Assembly Instructions for Series UHF Hoods	3.102
VSWR Data on Type "C" and "BNC" Coaxial Connectors	3.103
from the Polytechnic Institute of Brooklyn	
VSWR Data on Improved Type "N" Coaxial Connectors from	3.104
the Polytechnic Institute of Brooklyn	
VSWR Data on Improved Type "HN" Coaxial Connectors from	3.105
the Polytechnic Institute of Brooklyn	
 SECTION 4B - SWITCHES, COAXIAL AND WAVEGUIDE	
4-1 General consideration	4.1
Tables	
Guide to Selection of Preferred Coaxial Switches	4.2
Nonstandard Nomenclatured RF Coaxial Switches	4.5
Coaxial Switches Approved as Nonstandard Parts	4.5
Nomenclatured Waveguide Switches	4.6
Waveguide Switches Approved as Nonstandard Parts	4.6

MIL-HDBK-216
12 June 1975

	PAGE
SECTION 5A - RIGID COAXIAL TRANSMISSION LINES	
5-1 General Considerations	5.1
5-2 Tables	
Bead Supported Coaxial Lines	5.2
Physical Requirements	5.3
Electrical Requirements	5.4
TE ₁₁ Mode Cutoff Frequency (GHz)	5.4
Stub-supported Coaxial Lines	5.5
SECTION 6B - WAVEGUIDES	
6-1 General Waveguide Considerations	6.1
6-2 Rectangular Waveguides	6.8
6-3 Circular Waveguides	6.28
6-4 Flexible Waveguides	6.34
6-5 Ridged Waveguides	6.44
6-6 Elliptical Waveguide	6.47
6-7 Dielectric Waveguides	6.60
Tables	
Normalized Cutoff Wavelengths (λ_c/a for Circular Guides)	6.4
Modified Mathieu Function	6.5
Relative Breakdown Strength of Dielectric Gases	6.7
Material Properties	6.9
Waveguides, Rigid, Rectangular MIL-W-85/1	6.13
Engineering Information for MIL-W-85/1	6.16
Cross Reference and Flange Information for MIL-W-85/1	6.19
Waveguides, Rigid, Rectangular (millimeter wavelength)	
for MIL-W-85/3	6.21
Engineering Information for MIL-W-85/3	6.23
Cross Reference and Flange Information for MIL-W-85/3	6.24
Heavy Wall Waveguide for MIL-W-85/2	6.26
Engineering Information for MIL-W-85/2	6.26
Cross Reference and Flange Information for MIL-W-85/2	6.27
Reduced Height Waveguide for MIL-W-85/4	6.27
Engineering Information for MIL-W-85/4	6.28
Cross Reference and Flange Information MIL-W-85/4	6.28
Characteristics of Multimode Circular Waveguide in TE ₀₁ mode	6.33
Letter Multiplier	6.34
Material	6.34
Dimensions and Cross Reference for Circular Waveguides	
(MIL-W-23068)	6.35
Frequency Ranges and Engineering Information for Circular,	
Rigid Waveguides (MIL-W-23068)	6.36
Typical Displacement Values	6.44
Mechanical Properties of Flexible Waveguides	6.46
Single Ridged Waveguides	6.48
Double Ridged Waveguides	6.49
Single-ridged Waveguides, Bandwidth Ratio 2.4:1 (MIL-W-23351)	6.50
Single-ridged Waveguides, Bandwidth Ratio 3.6:1 (MIL-W-23351)	6.52
Double-ridged Waveguides, Bandwidth Ratio 2.4:1	
(MIL-W-23351/4)	6.54
Double-ridged Waveguides, Bandwidth Ratio 3.6:1 (MIL-W-23351)	6.56
Elliptical Waveguide Physical Characteristics	6.58
Elliptical Waveguide Electrical Characteristics	6.58

	PAGE
SECTION 7A - WAVEGUIDE COUPLINGS	
7-1 General Considerations	7.1
7-2 Specifications	7.3
7-3 Tables	
Waveguides and Fittings	7.3
Preferred Waveguide Flanges	7.4
Rectangular Waveguide Flanges	7.5
7-4 Ridge Waveguide Flanges	7.13
Tables	
Single-ridge Flanges - Bandwidth Ratio 2.4 to 1	7.14
Single-ridge Flanges - Bandwidth Ratio 3.6 to 1	7.15
Double-ridge Flanges - Bandwidth Ratio 2.4 to 1	7.16
Double-ridge Flanges - Bandwidth Ratio 3.6 to 1	7.17
7-5 Quick Disconnect-couplers	7.18
SECTION 8A - WAVEGUIDE ASSEMBLIES	
8-1 General considerations	8.1
8-2 Tables	8.1
Flexible Waveguide Assemblies	8.2
VSWR and Bandwidth Data for Bends, Corners and Twists (Rigid Waveguide Assemblies)	8.5
Cross Reference of CG to RF Types	8.6
Guide to Selection of Rigid Waveguide Assemblies	8.7
Rigid Waveguide Assemblies	8.8
SECTION 9A - WAVEGUIDE ADAPTERS	
9-1 General Considerations	9.1
9-2 Tables	
Preferred Waveguide Adapters	9.2
Waveguide Adapters	9.3
SECTION 10 - WAVEGUIDE SWITCHES	
10-1 General Considerations	10.1
10-2 Tables	
Waveguide Switches	10.2
SECTION 11 - FITTINGS FOR RIGID COAXIAL LINES	
11-1 General Considerations	11.1
11-2 Tables	
Fittings for Rigid Coaxial Lines	11.2
EIA Standard RS-225, Rigid Coaxial Transmission Line Flanges (50 ohms)	11.3

MIL-HDBK-216
28 April 1977

	PAGE
SECTION 7B - WAVEGUIDE COUPLINGS	
7-1 General Considerations	7.1
7-2 Dimensioning and Tolerancing	7.3
7-3 Waveguide Flanges and Coupling Assemblies	7.4
7-4 Cross-reference Tables	7.4
SECTION 8A - WAVEGUIDE ASSEMBLIES	
8-1 General Considerations	8.1
8-2 Tables	8.1
Flexible Waveguide Assemblies	8.2
VSWR and Bandwidth Data for Bends, Corners and Twists (Rigid Waveguide Assemblies)	8.5
Cross Reference of CG to RF Types	8.6
Guide to Selection of Rigid Waveguide Assemblies	8.7
Rigid Waveguide Assemblies	8.8
SECTION 9A - WAVEGUIDE ADAPTERS	
9-1 General Considerations	9.1
9-2 Tables	
Preferred Waveguide Adapters	9.2
Waveguide Adapters	9.3
SECTION 10 - WAVEGUIDE SWITCHES	
10-1 General Considerations	10.1
10-2 Tables	
Waveguide Switches	10.2
SECTION 11 - FITTINGS FOR RIGID COAXIAL LINES	
11-1 General Considerations	11.1
11-2 Tables	
Fittings for Rigid Coaxial Lines	11.2
EIA Standard RS-225, Rigid Coaxial Transmission Line Flanges (50 ohms)	11.3
SECTION 12 - DIRECTIONAL COUPLERS	
12-1 General Considerations	12.1
12-2 Tables	
Directional Couplers	12.2
Typical Couplers	12.9

Supersedes page v of 8 November 1976.

MIL-HDBK-216
8 November 1976

	PAGE
SECTION 13 - DUMMY LOADS	
13-1 General Considerations	13.1
13-2 Tables	
Dummy Loads	13.2
Typical Waveguide Dummy Load	13.3
SECTION 14 - ATTENUATORS	
14-1 General Considerations	14.1
14-2 Electrical parameters and definitions	14.2
Tables	14.3
Fixed attenuators approved as nonstandard parts	14.5
Variable attenuators (mechanical) approved as nonstandard parts.	14.10
SECTION 15 - ROTARY JOINTS	
15-1 General Considerations	15.1
15-2 Tables	
Solid-Dielectric Rotary Joints	15.2
Air-Dielectric Rotary Joints	15.4
SECTION 16 - MISCELLANEOUS NAVAL LINES AND FITTINGS	
16-1 General Considerations	16.1
16-2 Tables	
Miscellaneous Naval Lines and Fittings:	
1/4-inch O.D. coaxial lines (70-ohm, gas filled)	16.1
7/8-inch O.D. coaxial lines (70-ohm, gas filled)	16.1
1-5/8-inch O.D. coaxial lines (50-ohm, gas filled)	16.2
Miscellaneous Accessories for Gas-Filled Coaxial Lines	16.3
Miscellaneous Accessories for Solid-Dielectric Coaxial Cables	16.3
Concentric Patch Cords and Related Fittings	16.4
Wire Antenna Clamps	16.4
Instructions and Specifications	16.4
Hull Fittings	16.5
SECTION 17 - LIST OF DRAWINGS AND STANDARDS	17.1
SECTION 18 - NOMENCLATURE INDEX	18.1

Supersedes page v of 4 January 1962.

MLL-HDBK-216
SECTION 1A
18 May 1965
SUPERSEDING
Section 1
4 January 1962

SECTION 1A

INTRODUCTION

1-1 General:

This handbook provides pertinent information of R.F. Transmission Lines and Fittings, important assembly techniques and necessary fabrication precautions to insure optimum operational results and to minimize probability of failures. It is intended to provide essential technical information and guidance to personnel concerned with the preparation of procurement specifications for Radio Frequency Products and users of such items. This Handbook is not intended to be referenced in purchase specifications, except for informational purposes, nor shall any material included herein be considered to supersede any specification requirements.

This handbook is intended for use as a technical information guide to RF Transmission Lines and Fittings used by the Armed Services and supersedes ASES 49-2.

Each section opens with a brief description of major relevant facts pertaining to the group of components covered.

At the end of this handbook are provided various forms of data on Service drawings. Section 17 contains a cross-index of drawings versus component nomenclature. This listing includes issue letters of drawings. Section 18 contains a cross-index of nomenclature versus applicable drawings or specification and page number, to provide a simple method of locating specific items. Listing of parts herein does not imply acceptance by the individual services as standard parts.

MIL-HDBK-216
SECTION 1A
18 May 1965

1-2 Effects of environment:

The effects of environment on RF lines, waveguides, and their components, are directly related to the materials used in their construction. These items employ comparatively few types of materials, and they have been made the subject of careful study and improvement. The information that follows attempts to point out some of the overall causes of deterioration in performance, and suggested remedies where possible.

1-2.1 Temperature:

Temperature effects fall into two categories: Changes in performance, and long-time deterioration. The most apparent change will be the variation in attenuation values as the resistivity of the conductors increase or decreases proportionally with temperature. The temperature coefficient of resistivity varies with each material, being approximately 0.4 percent per degree C for copper. The permittivity and dissipation factor of the dielectric material are comparatively constant over its useful temperature range. Hence, the electrical parameters of the line, other than attenuation, are virtually independent of temperature fluctuations for short periods of time.

Much more troublesome are the effects of repeated cycling over wide temperature extremes, due to the large difference in thermal expansion rates between the metals and the thermoplastic materials, particularly for solid dielectric cables. Temperature cycling can lead to kinking. At elevated temperatures the dielectric is restrained radially, and undergoes an irreversible cold flow in the axial direction. Maximum temperature is ambient plus use, due to the power transmitted. Any residual process strains also tend to be relieved at the higher temperature, contributing to dimensional changes. When the temperature is subsequently reduced, a loose

MIL-HDBK-216
SECTION 1A
18 May 1965

mechanical fit can occur and markedly reduce the corona limit, and change the characteristic impedance slightly. This effect is even more pronounced in a cable as the fine braid wires can be expanded beyond their elastic limit. If the outer coverings, such as a glass fiber or steel braid, exert greater constraint, the longitudinal expansion may be sufficient in short lengths of polytetrafluoroethylene (PTFE) and long lengths of polyethylene dielectric cables to cause connectors to malfunction or even become dislodged. Recommended upper temperature limits for solid dielectric cables should be carefully observed to minimize such plastic flow which is greatly increased near the softening point. In long runs of rigid coaxial lines or waveguides, provision should be made for a sliding or flexible section to compensate for longitudinal expansion and contraction.

Natural chemical changes are also greatly accelerated when the materials are maintained at an elevated temperature. Metallic surfaces combine more readily at high temperatures with atmospheric gases and volatiles given off from the surrounding organic materials (for example, sulphur from rubber or chlorine from polyvinyl chloride). Silver platings on wire have been found to go into solid solution with copper after sustained exposure at 200°C. Conductors and spring contact members progressively lose their tensile strength, ductility, and flexibility. A similar embrittlement will also occur with many elastomer and plastic jacketing materials except urethane and PTFE. This will become evident by a rapid loss of pliability at sub-zero temperatures, and ultimate shattering or cracking.

Due to natural oxidation the dissipation factor of most dielectrics increases with time at a rate that is temperature dependent. In addition, polyethylene has a chemical affinity for some of the volatile plasticizers

MIL-HDBK-216
SECTION 1A
18 May 1965

used in vinyl jackets, which causes very large changes in dissipation factor. Special "non-contaminating" vinyl jackets must be used to maintain attenuation stability over long periods of time. PFTE is not affected by such aging.

1-2.2 Pressure and humidity:

Variations in pressure and humidity will affect permissible voltage and power ratings of transmission lines. The mechanisms controlling electric breakdown depend upon gas density which varies directly with the pressure and inversely the absolute temperature. Curves are available which relate pressure and temperature to altitude and permit correction of the maximum electric field strength. ^{1/} The corona level of solid dielectric cables requires the same correction data for sustained periods of high altitude operation. Gaseous diffusion takes place through the jacket and the dielectric so as to eventually equalize the internal pressure with that of the surrounding atmosphere. To overcome these limitations, and to minimize corrosion, some nominal pressurization is employed in almost all waveguides and rigid or semirigid air coaxial lines. For highpower applications the internal pressure is increased to two or three atmospheres without any undue stiffening or rupture of the flexible waveguide.

The density of the surrounding air also determines the ability of the lines or cable to dissipate heat from the outer surface by convection. At sea level, convection accounts for virtually all the heat dissipated, and hence determines the thermal power rating. Such ratings must be severely reduced, due to the rarified atmosphere encountered at high altitudes, unless provision can be made for removal of heat by radiation or conduction. For example, for PFTE cables the ratio of the power at sea level to that at any

^{1/} Air Force surveys in geophysics No. 115, AFCRC-TR-59-267, August 1959.

MIL-HDBK-216
SECTION 1A
18 May 1965

other altitude is equal to the ratio of the pressures raised to the 0.26 power. For polyethylene cables this ratio is raised to the 0.42 power.

Relative humidity is of little concern since most transmission line systems are sealed and the dielectric materials commonly used are nonhygroscopic; however, cavities in connectors such as series N can collect water. Certain elements of the system (for example, antenna feeds and sealing windows) will at times be subjected to a combination of high humidity and temperature sufficient to cause condensation of moisture on the exposed surfaces and possible arc over. Arc-resistant materials which do not carbonize, (for example, PTFE, glass, or glazed ceramics), should be used for these applications.

1-2.3 Atmospheric contaminants:

Precautions are required in the installation and in proper selection of finishes for exposed metallic lines and fittings to extend their useful life. Direct soil burial or locations where surface water cannot drain off freely should be avoided. Vertical runs of unsealed tubing should provide a "weep" hole at the lowest point in the line for the drainage of any accumulated moisture. Choke flanges can be particularly troublesome as water can accumulate in the recesses of the choke groove; therefore, they should be mounted with the groove pointing down to avoid water collection whenever possible. RTV type rubber should be used to seal connectors where the connectors are to be installed underground or in any exposed location where there is no need for frequent uncoupling.

Metals are susceptible to electrolytic corrosion as a result of salt spray, or chemical fumes such as sulphur, hydrogen sulphide, or carbon monoxide, which form electrolytes in the presence of moisture. The copper and silver alloy

MIL-HDBK-216
SECTION 1A
18 May 1965

materials are least affected and aluminum and magnesium alloys are most affected by corrosion of this type. Precious metal or oxide coatings used in the interior surfaces must have good electrical conductivity. However, the former are too costly and the latter are mechanically inadequate for external use without additional protection. An appropriate two-coat paint system should be used in accordance with the procedures of MIL-F-14072, "Finishes for Ground Signal Equipment." ^{2/} Direct contact of dissimilar metals widely displaced in the galvanic series, such as the mating of aluminum and brass flanges, must be avoided. Where there is no alternative, both surfaces must be given a final plating of the same material; or a separator of an inert material must be used to prevent electrolytic action.

Cable jacket materials are quite resistant to all forms of atmospheric corrosion and fungi attack encountered in external locations. They are capable of one to three years of direct soil burial with only slight attack by the micro-organisms in the soil. However, except for PFTE and urethane, these materials may suffer deleterious effects from the oils, gasolines, solvents, or hydraulic fluids normally encountered in aircraft, vehicular, or ground installations in which they are used. The vinyl materials are most resistant to these chemicals while the rubber materials, with the exception of neoprene, will all swell and soften on prolonged exposure. Silicone rubber is particularly poor in the presence of gasoline. Kel-F and PFTE are the only materials resistant to the effect of fuming nitric acid.

1-2.4 Mechanical factors:

Rigid lines and cables are quite rugged, and can withstand normal field handling with a few simple precautions. Long vertical runs should be supported

^{2/} NAVSHIPS 900-171, Chapter 11, contains the painting procedures employed by the Navy.

MIL-HDBK-216
SECTION 1A
18 May 1965

periodically to remove the full stress from the couplings, particularly for cable connectors with spring loaded coupling rings. Static compression will cause a semi-permanent deformation (that is, cold flow) of the thermoplastic dielectric and jacket materials. This constriction of the cross section causes a loss of sealing and introduces an additional VSWR at the connector junction. For air spaced cables, an auxiliary dielectric support should be used to support the conductor at the connector.

The radii of curvature should be kept as large as possible during installation, as sharp bends in cable introduce mechanical stress in the jacket and, to a lesser degree, on the dielectric. These stresses greatly accelerate the cracking of the jacket in the presence of ultraviolet rays in sunlight, and atmospheric ozone which is greatly increased in the presence of corona. The center conductor tends to migrate outward and has been known to short circuit to the braid under extremes of temperature cycling. Thick sections of low molecular weight polyethylene also rupture in contact with certain common soaps, greases, alcohols, and solvents when subjected to a biaxial stress. All these chemical reactions increase rapidly with temperature. Wherever possible, right-angle fittings should be used to eliminate sharp bends.

Most coaxial cables have been designed primarily to permit reeling and unreeling rather than for any continuous flexure or twisting. If a limited degree of flexure is necessary, the cable should be installed so that the radius of bend changes in one direction only, rather than undergoing a reversal. All cables stiffen at low temperatures; the plastic materials much more rapidly than the elastomeric materials. Cables stored at subzero temperatures should be warmed prior to bending, because the

MIL-HDBK-216
SECTION 2A
18 May 1965

forces involved become very high and can cause cracking of the jacket. Under continuous flexure or twisting, the braid will loosen and reduce the corona levels, and also cause erratic attenuation at the higher frequencies. In moderate twisting, the braids will usually fail first after about 10,000 cycles due to the high degree of abrasion they receive in the comparatively stiffer plastic cables. For predominant flexure, the center conductor will break first. Where extreme flexibility is desired, special constructions of the inner conductor and braid must be used as well as very elastic dielectrics.

Solid sheath cable should be fastened in a manner so as to minimize any vibration. All the ductile materials will work harder and eventually crack due to cyclic stress.

1-2.5 Nuclear radiation:

The type and intensity of nuclear radiation will vary greatly with the nature of the source, the distance from the source, and the duration of the exposure. The effects which take place immediately, such as in an explosion, are a function of the radiation flux or "dose rate."

Degenerative effects associated with the total integrated dose absorbed (that is, the product of the dose rate and the time duration at the rate) are considerably different. The extent of damage sustained by any particular component will depend on its chemical composition, the total dosage, and the dose rate.

Quantitative data secured during an atomic blast are very limited and of a highly classified nature. However, extensive evaluation has been undertaken of the effect of radiation on materials required for electronic instrumentation and control of nuclear reactors. The correlation of such

MIL-HDBK-216
SECTION 1A
18 May 1965

data on materials into quantitative performance is lacking, but a brief discussion of the behavior of the materials in common use is considered timely.

In close proximity to a reactor core, extremely high intensities of fast neutron and gamma radiations are emitted over a wide energy spectrum. The primary shield around the reactor will convert the fast neutrons to slow or thermal neutrons and reduce their intensity by a factor of 10^3 to 10^5 while gamma radiation is reduced by a factor of 10^2 to 10^4 . Beyond the secondary shield, radiation effects are negligible.

Metals or their alloys are least affected, and although some radioactive isotopes may be formed, they are generally of short life. Some small changes in the mechanical and electrical properties of metals have been observed over the region of interest but generally they are not significant. The effect of nuclear radiation causes resistivity of copper to increase above the resistance values at 27°C and -163°C by 0.25 percent and 30 percent, respectively. Certain metals, such as boron and cadmium, have a great neutron affinity and hence their atoms form an excellent shield against thermal neutrons. Plating, coatings, or dispersions of these materials in a binder such as polyethylene, are being used for protective purposes. Lead and tungsten are used to absorb gamma rays.

Most plastics and elastomers tend to decompose or cross link under sustained nuclear radiation. In the cross-linking process, materials such as polyethylene, polystyrene, nylon, neoprene, and silicones become more rigid, brittle, and thermostable. In fact, a limited amount of radiation improves the upper temperature limit of polyethylene, and such materials that decompose to the monomers or other degradation products are polyvinyl chloride, butyl

MIL-HDBK-216
SECTION 1A
18 May 1965

rubber, Kel-F, and PTFE. PTFE may be used in the presence of ionizing radiation if no oxygen is present as in the case of orbiting satellites or in vacuum chambers.

Inorganic materials such as ceramics, ceramic oxide, and carbides are superior in performance to the organic materials indicated above. They can be used as rigid dielectric or as fillers in the flexible organic material to overcome some of their limitations.

Copper band alloys should not be used in connectors exposed to radiation.

1-3 Installation notes:

Carefully remove all filings, loose solder and similar foreign particles prior to assembly. Cleanliness should be observed in all operations.

Seal the ends of all lines and cables during storage to prevent the ingress of moisture or dirt; protect them from dents or bruises which can cause latent operating defects.

Provide an adequate number of gas servicing vents for free circulation in pressurized systems; check for leaks periodically and make sure that the dehumidifier is operating adequately.

Avoid flexing radii smaller than ten times the diameter of the cable and provide sufficient slack for shock mounted equipment; use strain relief on connectors where flexing is involved. Fixed bends with radii as small as five times the cable diameter can be used with cables having type II A jackets and type A dielectric.

Separate or shield cables operating at low power levels from those carrying high RF power or control power to minimize interference.

MIL-HDBK-216
SECTION 1A
18 May 1965

Select items from preferred or standard lists - the apparent advantages of a nonstandard item are generally offset by the maintenance of special fittings, test instrumentation, and so on.

Use the least number of waveguide couplings possible; good preformed bends or flexible assemblies contribute less to the overall system VSWR.

Exercise extreme care in the assembly and grounding of all fittings operating at high voltage to reduce corona and radiated noise; grounding should be done at several points for long runs.

Use adjustable hanger straps or clamps to relieve strain on rigid lines; use additional resilient protection such as tubing or tape wrap for cable.

Follow recommended assembly instructions for coaxial cable connectors to assure proper VSWR and voltage rating during operation.

Select items well within their electrical and thermal ratings.

Use straighteners and special bending tools for the proper installation of solid sheath, semiflexible cables.

Do not permit cable to be stored or installed in close proximity to "hot spots," such as heat dissipative tubes or resistors, steam or exhaust pipes.

Do not assemble cables with magnesium oxide dielectric without discarding the first 2 to 3 inches and drying the ends thoroughly.

Do not exert excessive forces in tightening fittings containing rubber or plastic as permanent deformation will result; occasional light retightening is preferred.

Do not force flexible waveguides beyond their natural "stop" position; contact will be broken in the guide or at the flange.

Do not subject ceramic insert pulse connectors to shock - they crack easily.

MIL-HDBK-216
SECTION 1A
18 May 1965

Do not apply more heat than necessary in soldering, brazing, or welding connections; where possible, use crimped connections on cable braids to prevent distortion of the dielectric.

Do not operate waveguides too close to their cutoff limits for high-power use; select a guide size so that the desired frequency will be close to midband.

1-4 Composite systems:

In the selection of a transmission line system, the equipment designed will establish certain parameters over which the component engineer has very little control, such as the frequency band, the type of signal modulation, and the power level. The overall insertion loss and the VSWR of any proposed transmission line system must be considered with respect to its effect on the power available at the antenna, the frequency stability, the receiver signal-to-noise ratio, and so on. The size, weight, and complexity of additional circuitry or auxiliary devices to overcome these deficiencies must be compared to any possible improvements in the transmission line. The transmission line and its shipping containers can be a significant factor in the volume, weight, and mobility of any tactical piece of equipment. Flexibility and simplicity of installation are often gained at the cost of greater attenuation, which may or may not be accompanied by a loss of power capability. Since the peak voltage rating of the cable is always higher than that of the connectors and terminations, the rating of the line is limited by the rating of the connectors and terminations.

1-5 Lines vs. guides:

A good compromise can be achieved by a combination of transmission lines inasmuch as efficient transitions or adaptors are available for such

MIL-HDBK-216
SECTION 1A
18 May 1965

interconnections. For minimum attenuation and maximum power, waveguides should be used. However, these parameters are established once a frequency range and cross section has been selected. They are limited to a frequency range of 1.4:1; this can be extended to 4.0:1 at considerable sacrifice of performance, but with a reduction in size. Auxiliary components to perform a myriad of electrical and mechanical functions are available in waveguide structures. The great majority of them will be usable over the entire waveguide band with a reasonably low VSWR. There are certain design limitations imposed on other components due to the variation of guide wavelength over the frequency range of the waveguide.

Where band width is of primary concern, coaxial lines can span four to six decades of frequency with no difficulty. They offer considerable savings in size and weight at frequencies below 1,000 Mc, where waveguide dimensions become prohibitive. Coaxial lines are available over a wide size range permitting a choice of attenuation and power handling capacities that is independent of frequency up to their cutoff. Flexible coaxial cables are the most versatile in application up to approximately 10,000 Mc. A majority of the associated coaxial components will operate over the full frequency range of the line size. Design is simplified by the fact that the waveguide length is independent of frequency. Certain components are difficult to design due to the radial field configuration, and difficult to manufacture because of coaxial geometry.

In addition, special configurations of waveguides and coaxial lines are used to advantage in design and fabrication of components. For example, "strip line" consists of a flat center conductor separated from a single ground plain ("open" type) or between symmetrical ground planes ("closed" or

MIL-HDBK-216
SECTION 1A
18 May 1965

or shielded type). Strip line can be used to produce components or combinations thereof with minimum size and weight and at low cost by automatic production techniques. Data on these and other special types have not been included here as they are not considered general-purpose transmission lines.

MIL-HDBK-216
SECTION 2A
18 May 1965
SUPERSEDING
Section 2
4 January 1962

SECTION 2A

R. F. CABLES

2-1 General considerations.

Flexible cables are the simplest, most versatile and popular means of transmission of RF and microwave energy. Since 1942, they have been improved continually with regard to temperature range, attenuation stability, and operating voltage. Their extensive use has also been a major incentive for the development of new high-frequency dielectric materials and new production techniques. Coaxial cables have been made in a wide range of sizes and electrical characteristics.

Most coaxial cables consist of the same basic elements: a center conductor, a low-loss solid or semisolid dielectric, and one or more braided outer conductors followed by a waterproof covering. Over the covering, medium and large size cables may also have an armor, or a lead sheath, or lead sheath and an armor. Other types of RF Cables are twin-conductor or shielder pair and dual-coaxial cables. The shielded pair consists of two parallel conductors separated from each other and surrounded by an insulating dielectric material. The conductors are contained within a copper-braid tubing which acts as a shield for them. This assembly is covered with a rubber or flexible-composition coating to protect the line against moisture and friction. The outstanding advantage of the shielded pair is that the two conductors are balanced to ground. The dual-coaxial consist of two coaxial cables with individual shields covered by a common shield and jacket. Many compromises are involved as to the choice of materials and constructional features of each of these elements to attain

MIL-HDBK-216
SECTION 2A
18 May 1965

good overall electrical and mechanical performance under a wide range of environments. Some of these factors are discussed briefly below.

A. Center Conductor. Solid copper is used for conductors above approximately 0.100 inch in diameter and concentric stranded conductors (7, 19, or 27 strands) below 0.100 inch for greater flexibility except for certain miniature cables where adequate flexibility can be achieved with a solid conductor. In these small size cables, the majority of the flexing stress is absorbed by the dielectric and jacketing materials whose strength exceeds that of the conductor. Thus, the conductor does not, in general limit the flex life of the completed cable.

Single copper-clad steel conductors also provide good flexibility and add mechanical strength in the small and miniature sizes and in the airspaced cables. Silver coatings are necessary on high-temperature cables to prevent rapid oxidation of the copper during processing and use. Nickel coatings are also used for this purpose. Tin coatings are used to facilitate soldering of cables to fittings.

Tin- and nickel-plated conductors should be limited to low frequency applications where the thickness of the coating will not increase the conductor attenuation significantly.

B. Dielectric. Polyethylene is used almost exclusively where the maximum temperature will not exceed 85°C. It is extruded directly over the center conductor in either a solid or airspaced form. Polytetrafluoroethylene (Teflon) is required when temperatures from 85° to 250°C are encountered in the vicinity of the dielectric. It may be extruded and sintered in solid form or built up from layers of tape to achieve greater flexibility. A high-temperature sealing compound is sometimes used to fill the voids in a taped

MIL-HDBK-216
SECTION 2A
18 May 1965

cable, thereby raising its corona level or maximum operating voltage. In the miniature sizes unsintered tapes are sometimes used since they can be heat fused after application. This also tends to minimize the number of voids in the dielectric.

The Helical Membrane cable uses a thin flat ribbon of either polyethylene or Teflon to support the inner conductor. This membrane is obtained by cutting a spiral in a hollow dielectric tube of precise size, and an aluminum sheath is drawn down tightly over the open spiral. This construction results in a slightly lower permittivity, attenuation, and cost than the Styroflex, but is not as rugged. It is feasible over the size range from 0.475 to 3.125 inches. Greater care must be taken in the installation to assure that slippage of the center conductor does not occur due to bends, thermal expansion, or a combination thereof.

Heliac cables are air dielectric, semi-flexible coaxial cables. A helical ribbon of polyethylene or Teflon supports the inner conductor within a corrugated high conductivity copper outer conductor. These cables are available jacketed or unjacketed in sizes from 3/8" through 5" diameters. Jacketed cables include a special weatherproof flooding compound and black polyethylene jacket. No straightening or bending tools are required for field installation and connectors may be applied with ordinary tools. The ability of the outer conductor to withstand flexure (50-100 times) about a radius ten times its overall diameter permits reasonable reuse of the cable.

Heliac cable with foam polyethylene dielectric is also available in sizes 1/2" thru 1-5/8". These cables require no pressurization and are available jacketed or unjacketed.

The dielectric of a semiflexible line may be either an airspaced structure or a continuous form of solid insulation. In the former, a continuous ribbon

MIL-HDBK-216
SECTION 2A
18 May 1965

or rod of dielectric material is spiralled openly with a uniform pitch around the center conductor to support it and to maintain a low effective permittivity. Some semiflexible cables are manufactured with a continuous laminated helix composed of thin flexible oriented polystyrene tapes. The high tensile and compressive strengths of this type of film (10,000 to 13,000 psi) and the wrapping technique permits the finished cable to withstand high tensile forces and crushing load. Another type of semiflexible cable use dielectrics of compressed high density polyethylene tubes which eliminate a direct air path between the center and outer conductor and provide individual air cells. Strength is added to the cable by the continuous radial web support of the dielectric tube. Overall dimensions range from 3/8 to 6-1/8 inches and closely follow rigid line practice.

The second category of semiflexible cable uses a solid or continuous form of dielectric in the size range from 0.080 to 0.750 inch. One of the early types (RG-81 and 82/U) uses a highly purified, compacted magnesium oxide insulation, with soft copper conductors. The attenuation of these Pyrotenax cables is somewhat high, particularly at the higher frequencies, and the insulation is very hydroscopic when exposed to the atmosphere. More recent designs use polyethylene or foamed polyethylene with an aluminum sheath. The introduction of a solid dielectric increases the peak operating voltage and the attenuation, but lowers the thermal resistance sufficiently to retain the equivalent power handling capacity of an airspaced line. Semiflexible lines without a jacket have a smaller volume and improved power rating in comparison to flexible cables of the same diameter over the dielectric. The solid outer conductor also has a lower attenuation than a braided cable. The solid dielectric semiflexible cables can be permanently sealed for high altitude or for submarine use without the need for auxiliary pressuring equipment.

MIL-HDBK-216
SECTION 2A
18 May 1965

The electrical properties of these airspaced cables are very similar to rigid lines below 100 Mc. In this region, the aluminum outer conductor increases the attenuation about 6 percent. Above 100 Mc, this difference gradually increases with frequency to an ultimate value of 35 to 45 percent above the equivalent size rigid line at cutoff. The impedance variation with frequency is also slightly larger, but still below a VSWR of 1.08 as a result of minor irregularities in the dielectric structure and dimensions of the outer conductor. However, close to the upper frequency limit, a marked lowering of the impedance has been observed due to an increased concentration of the electric field in the dielectric. These cables should be installed with sealed fittings and maintained with a positive dry gas pressure. Fittings are available that are compatible with both rigid lines and flexible cables.

C. Outer conductor. A single close fitting braid of fine copper wire (0.010 to 0.004 inch) is used most frequently. Tin- or silver-coated are used for the same reasons as on the center conductor, as well as reducing the apparent RF resistance of the braid. A second braid of either copper or steel is used to improve shielding. The second braid has only a secondary effect on the attenuation and is designed primarily for shielding.

D. Jacket. Black vinyl resins are extruded or tubed over the outer conductor of all polyethylene dielectric cables. Cables with PTFE dielectric have a close wrap of PTFE tape, or an extruded FEP jacket, followed by one or more glass braids impregnated with a silicone varnish, although the latter may be omitted and only used the jacket or FEP. An extruded rubber sleeve with a Dacron braid impregnated with a fluorocarbon lacquer can be used to improve the very poor abrasion resistance of the glass braids. For miniature cables, a wide variety of jacket materials is available with different upper temperature limits, such as extruded PTFE (FEP) (200°C) or heat-fused tapes or

MIL-HDBK-216
SECTION 2A
18 May 1965

PFTE-impregnated glass (260°C), extruded monochlorotrifluoroethylene (H Kel-F, Fluorothane, or Polyfluron) (135°C to 150°C), extruded nylon over vinyl or heat fused or lacquered nylon braid (105° to 125°C). High molecular weight polyethylene pigmented black, for polyethylene cable is also being used where the temperature will be kept below 85°C.

E. Protective coverings. A close braid of aluminum armor and paint is applied over the jacket for shipboard installations. An armor also protects the jacket against cuts and tears in hazardous locations or during burial in rocky terrain. Cables for permanent burial in wet locations have a lead sheath over the jacket for added long-time moisture resistance. A serving of heavy duty galvanized steel armor wire, embedded in layers of asphalted jute, is necessary for the installation and recovery of these heavy leaded cables.

There are many constructional variations between the rigid coaxial lines and flexible cables which fall in the broad category of semiflexible lines. These lines can be fabricated and shipped in continuous lengths to 2000 feet, which can be formed into moderate bends during installation. The outer conductor is a smooth-drawn or corrugated tubing of a ductile metal. Additional protective coverings may be added for greater abrasion and corrosion resistance.

Precautions should be taken to prevent "work hardening" and eventual cracking of the sheath from continual vibration. Copper sheath is better than aluminum from the standpoint of vibration resistance. These cables can withstand short-time operation in the presence of open flames. Sustained use above their rated temperature will cause damage to the cable sheath due to the relatively large thermal coefficient of expansion of the dielectric. However, mineralinsulated types can be used up to 250°C for limited operation up to about 100 hours, and close to the softening point of copper under emergency conditions.

MIL-HDBK-216
SECTION 2A
18 May 1965

Unprotected copper or aluminum can be used outdoors in dry locations or in aerial installations where there is no danger of electrolytic action. In wet locations, or in the presence of corrosive vapors, the sheath should be protected with asphalt coated tapes, or a jacket of black polyethylene or vinyl. A metallic armor is recommended for additional mechanical protection when underground or underwater burial is required.

The cable should not be dragged across rough terrain that may cut, fracture or in any way damage the cable; nor should the cable be allowed to lay unprotected on the ground where it is subject to heavy vehicle traffic.

2-2 Tables

This part contains information pertaining to flexible, and semi-flexible RF cables. It includes a Guide to the Selection of Preferred RF Cables, a complete numerical list of RF cables and data on the attenuation and power handling capacity of many cables. The Guide contains those cables which have been selected by the Armed Services as the most satisfactory types of radio frequency cables to be used in electronic equipment. Preference should be given to NATO preferred types of cable. The purpose of this Guide is to standardize new RF cable types and to reduce the number of types of radio frequency cables used in the equipment of the Armed Services.

MIL-HDBK-216
SECTION 2A
18 May 1965

GUIDE TO SELECTION OF PREFERRED RF CABLES

Class of cables	JAN type	MATO type	Inner conductor	Dielectric material	Nominal diameter of dielectric	Shielding braid	Protective covering	Nominal overall diameter	Weight lb/ft	Approximate impedance	Nominal capacitance uMf/ft	Maximum operating voltage Volts (rms)	Remarks
GENERAL PURPOSE	RG-6A/U		21 AWG copper covered steel	A	0.185	Inner Silver coated copper braid	11a	0.332	---	76.0	20.0	2,700	Small size, video and communication cable
	RG-11A/U	WR13S	7/32 inch silver coated copper	A	0.285	Copper braid	11a	0.412	---	75.0	20.5	3,000	Medium size, flexible video cable
	RG-12A/U	WR18	7/25 inch silver coated copper	A	0.285	Copper, single braid	11a	0.425	---	75.0	20.5	3,000	Similar to RG-11A/U but with armor
	RG-13A/U	WR18	7/25 inch silver coated copper	A	0.285	Copper, single braid	11a	0.425	---	75.0	20.5	3,000	Similar to RG-11A/U but with armor
	RG-15A/U	WR20	7/16 inch silver coated copper	A	0.380	Copper, single braid	11a	0.530	0.231	75.0	21.5	6,500	Large size, high power, low attenuation, flexible cable
	RG-17A/U	WR20	7/16 inch silver coated copper	A	0.380	Copper, single braid	11a	0.530	0.480	75.0	21.5	10,000	Large size, high power, low attenuation, video and communication cable
	RG-18A/U	WR20	7/16 inch silver coated copper	A	0.380	Copper, single braid	11a	0.530	0.480	75.0	21.5	10,000	Large size, high power, low attenuation, video and communication cable
	RG-19A/U	WR20	7/16 inch silver coated copper	A	0.380	Copper, single braid	11a	0.530	0.480	75.0	21.5	10,000	Large size, high power, low attenuation, video and communication cable
	RG-20A/U	WR20	7/16 inch silver coated copper	A	0.380	Copper, single braid	11a	0.530	0.480	75.0	21.5	10,000	Large size, high power, low attenuation, video and communication cable
	RG-21A/U	WR20	7/16 inch silver coated copper	A	0.380	Copper, single braid	11a	0.530	0.480	75.0	21.5	10,000	Large size, high power, low attenuation, video and communication cable
	RG-22A/U	WR20	7/16 inch silver coated copper	A	0.380	Copper, single braid	11a	0.530	0.480	75.0	21.5	10,000	Large size, high power, low attenuation, video and communication cable
	RG-23A/U	WR20	7/16 inch silver coated copper	A	0.380	Copper, single braid	11a	0.530	0.480	75.0	21.5	10,000	Large size, high power, low attenuation, video and communication cable
	RG-24A/U	WR20	7/16 inch silver coated copper	A	0.380	Copper, single braid	11a	0.530	0.480	75.0	21.5	10,000	Large size, high power, low attenuation, video and communication cable
	RG-25A/U	WR20	7/16 inch silver coated copper	A	0.380	Copper, single braid	11a	0.530	0.480	75.0	21.5	10,000	Large size, high power, low attenuation, video and communication cable
	RG-26A/U	WR20	7/16 inch silver coated copper	A	0.380	Copper, single braid	11a	0.530	0.480	75.0	21.5	10,000	Large size, high power, low attenuation, video and communication cable
	RG-27A/U	WR20	7/16 inch silver coated copper	A	0.380	Copper, single braid	11a	0.530	0.480	75.0	21.5	10,000	Large size, high power, low attenuation, video and communication cable
	RG-28A/U	WR20	7/16 inch silver coated copper	A	0.380	Copper, single braid	11a	0.530	0.480	75.0	21.5	10,000	Large size, high power, low attenuation, video and communication cable
	RG-29A/U	WR20	7/16 inch silver coated copper	A	0.380	Copper, single braid	11a	0.530	0.480	75.0	21.5	10,000	Large size, high power, low attenuation, video and communication cable
	RG-30A/U	WR20	7/16 inch silver coated copper	A	0.380	Copper, single braid	11a	0.530	0.480	75.0	21.5	10,000	Large size, high power, low attenuation, video and communication cable
	HIGH TEMPERATURE	RG-115/U		7/32 inch silver coated copper	F-2	0.250	Silver covered copper, double braid	11a	0.412	---	50.0	28.5	1,900
RG-128A/U		WR25	7/32 inch silver coated copper	F-2	0.250	Silver covered copper, double braid	11a	0.412	---	50.0	28.5	1,900	Similar to RG-115/U except cable core is teflon
RG-142/U		WR16	7/32 inch silver coated copper	F-2	0.250	Silver covered copper, double braid	11a	0.412	---	50.0	28.5	1,900	Small size flexible cable
RG-142A/U		WR16	7/32 inch silver coated copper	F-2	0.250	Silver covered copper, double braid	11a	0.412	---	50.0	28.5	1,900	Similar to RG-142/U except cable core is teflon
RG-157/U			7/32 inch silver coated copper	F-2	0.250	Silver covered copper, double braid	11a	0.412	---	50.0	28.5	1,900	Small size flexible cable
RG-157A/U			7/32 inch silver coated copper	F-2	0.250	Silver covered copper, double braid	11a	0.412	---	50.0	28.5	1,900	Similar to RG-157/U except cable core is teflon
RG-162/U			7/32 inch silver coated copper	F-2	0.250	Silver covered copper, double braid	11a	0.412	---	50.0	28.5	1,900	Small size flexible cable
RG-162A/U			7/32 inch silver coated copper	F-2	0.250	Silver covered copper, double braid	11a	0.412	---	50.0	28.5	1,900	Similar to RG-162/U except cable core is teflon
RG-167/U			7/32 inch silver coated copper	F-2	0.250	Silver covered copper, double braid	11a	0.412	---	50.0	28.5	1,900	Small size flexible cable
RG-167A/U			7/32 inch silver coated copper	F-2	0.250	Silver covered copper, double braid	11a	0.412	---	50.0	28.5	1,900	Similar to RG-167/U except cable core is teflon
RG-172/U		7/32 inch silver coated copper	F-2	0.250	Silver covered copper, double braid	11a	0.412	---	50.0	28.5	1,900	Small size flexible cable	

GUIDE TO SELECTION OF PREFERRED RF CABLES

MIL-HDBK-216
SECTION 2A
18 May 1965

GUIDE OF SELECTION OF PREFERRED RF CABLES (Continued)

Class of cable	JM type	Inner conductor	Dielectric material 1/	Nominal diameter of dielectric	Shielding braid	Protective covering 2/	Nominal over-all diameter	Weight	Approximate impedance	Nominal capacitance	Maximum operating voltage	Remarks
Rigid coaxial cables	RG-302/U	0.025 in. silver covered copper covered steel	F-1	0.146	Silver covered copper, single braid	IX	0.206	---	75.0	21.0	2,300	
	RG-303/U	0.099 in. silver covered copper covered steel	F-1	0.116	Silver covered copper, single braid	IX	0.170	---	90.0	28.5	1,900	
	RG-304/U	0.059 in. silver covered copper covered steel	F-1	0.185	Silver covered copper, single braid	IX	0.280	---	50.0	28.5	3,000	
Semi-rigid cables	RG-25A/U	19/.0117 in. tinned copper	E	0.288	Tinned copper braid	IV	0.505	0.205	48.0	50.0	10,000	High voltage cable
	RG-26A/U	19/.0117 in. tinned copper	E	0.288	Tinned copper single braid	IV with armor	0.505	0.189	48.0	50.0	10,000	High voltage cable
	RG-27A/U	19/.0185 in. tinned copper	D	0.455	Tinned copper single braid	IV with armor	0.670	0.304	48.0	50.0	15,000 peak	Large size cable
	RG-28B/U	19/.0185 in. tinned copper	D	0.455	Inner tinned copper; outer galv. steel	IV	0.750	0.370	48.0	50.0	15,000 peak	Large size cable
	RG-64A/U	19/.0117 in. tinned copper	E	0.288	Tinned copper double braid	IV	0.475	0.205	48.0	50.0	10,000	Medium size cable
	RG-68/U	19/.0117 in. tinned copper	E	0.288	Tinned copper four braids	11a	0.515	---	48.0	50.0	10,000	Four braid, medium size; multi-shielded high voltage cable
	RG-156/U	7/21 MGC tinned copper	First layer I second layer H	0.285	Inner, tinned copper; outer galvanized steel. Double braid	11a	0.540	0.211	50.0	30.0	10,000	Taped inner-layers, first layer type I and second layer type A-18, between the outer braid of the outer conductor and the tinned copper shield.
	RG-197/U	19/24 MGC tinned copper	First layer H second layer A third layer H	0.455	Tinned copper outer shield	11a	0.725	0.317	50.0	38.0	15,000	Tri-axial pulse cables.
	RG-198/U	37/21 MGC tinned copper	First layer H second layer A third layer H	0.455	Tinned copper outer shield	11a	0.725	0.380	25.0	78.0	15,000	Tri-axial pulse cables.
	RG-190/U	19/0.0117 inch tinned copper	First layer H second layer J third layer K	0.380	Inner, tinned copper; outer, galvanized steel. Double braid. Tinned copper shield	VIII over one wrap of type K	0.700	0.359	50.0	50.0	15,000	Taped inner-layers, 2 wraps of type I and 2 wraps of type L, between the outer braid and tinned copper shield.
	RG-191/U	30 MGC tinned copper. Single braid over supporting elements. 0.485 inch max	First layer E. second layer F. third layer H	1.065	outer, galvanized steel. Double braid. Tinned copper shield	VIII over one wrap of type K	1.460	1.469	25.0	85.0	15,000	Pulse cable

MIL-HDBK-216
SECTION 2A
18 May 1965

PROPOSED
GUIDE TO SELECTION OF PREFERRED WIRE CABLES (Continued)

Class of cables	JAN type	MILTO type	Inner conductor	Dielectric material 1/	Nominal diameter of dielectric	Shielding braid	Protective covering 2/	Nominal over-all diameter	Weight	Approximate impedance	Nominal capacitance	Maximum operating voltage	Remarks
	NO-228/U		Two conductors 7/.0152 inch anneal	A	0.285	Tinned copper; double braid	11a	0.420	0.116	95.0	16.0	1,000	Small size, balanced, twi conductor cable
	NO-97A/U		2 conductor 7/0.285 inch anneal	A	0.472	Tinned copper single braid	11a	0.625	0.225	95.0	17.0	3,000	Twis conductor
	NO-42A/U	MIL12	.0253 inch solid copper- covered steel	A	0.146	Copper; single braid	11a	0.242	0.282	93.0	14.5	750	
	NO-63B/U	MIL14	.0253 inch copper covered steel	A	0.285	Copper; single braid	11a	0.405	0.082	125.0	10.0	1,000	Medium size, low cap- acitance air-speed cable
	NO-45A/U	MIL12	No. 32 Formex F .128 inch dia. (solid)	A	0.285	Copper; single braid	11a	0.405	0.096	95.0	44.0	1,000	High impedance video cable. High delay line
	NO-71B/U		.0253 in. copper covered steel	A	0.146	Tinned copper; double braid	111A	0.290 (max)	---	93.0	14.5	750	Low capacitance cable
	NO-79B/U		.0253 inch copper covered steel	A	0.285	Copper; single braid	11a with armor	0.475 (max)	0.138	125.0	10.0	1,000	Same as NO-63B/U but with armor
	NO-111A/U		Each conductor 7/.0152 inch anneal	A	0.285	Tinned copper; double braid	11a with armor	0.490	0.145	95.0	16.0	1,000	Same as NO-228/U but with armor
	NO-130/U		Each conductor 7/.0285 inch plain copper wire	A	0.472	Tinned copper; single braid	I	0.625	0.220	95.0	17.0	8,000	Same as NO-97/U, except inner conductors twisted to improve flexibility
	NO-131/U		Each conductor 7/.0285 inch plain copper wire	A	0.472	Tinned copper; single braid	I with aluminum armor	0.710	0.295	95.0	17.0	8,000	Same as NO-130/U but with armor
	NO-178B/U		7/0.004 inch silver covered copper covered steel	F-1	0.034	Silver covered copper; single braid	II	0.075 (max)	---	50.0	29.0	1,000	
	NO-179B/U		7/0.004 inch silver covered copper covered steel	F-1	0.053	Silver covered copper; single braid	II	0.105	---	50.0	1,200		
	NO-180B/U		7/0.004 inch silver covered copper covered steel	F-1	0.102	Silver covered copper; single braid	II	0.145	---	95.0	14.5	1,500	
	NO-218A/U		Two conductors 7/28 AWG copper	A	0.210	Copper, inner braids Copper common braid	11a	0.640	---	125.0	12	3,500	Filled to round trans- mission unbalanced cable. Twis-conduct.
	NO-187A/U	MIL22	7/.004 inch an- nealed silver covered copper covered steel wire	F-1	0.060	Silvered copper; single braid	VII	0.110	---	75.0	---	1,200	High temperature miniaturized cable
	NO-195A/U		7/.004 inch an- nealed silver covered copper covered steel wire	F-1	0.102	Silver covered copper; single braid	VII	0.155	---	95.0	---	1,500	High temperature miniaturized cable
	NO-196A/U	MIL23	7/.004 inch an- nealed silver covered copper covered steel wire	F-1	0.034	Silver covered copper; single braid	VII	0.080	---	50.0	---	1,000	High temperature miniaturized cable
	NO-301/U		7/.0203 inch Karni wire	F-1	0.185	Karni wire; single braid	IX	0.245	---	50.0	29.0	3,000	High attenuation cable
	NO-307A/U		17/0.0058 inch silver covered copper	A Foamed	.029	Silver covered copper	111A	0.370	---	75.0	20	400rms	
	NO-314/U		7/.0067 inch an- nealed silver covered copper covered steel wire	F-1	0.060	Silver covered copper; single braid	IX	0.102	---	50.0	---	1,200	High temperature miniaturized cable

1/ Dielectric materials:

- A Polyethylene
- B Layer of synthetic rubber between two layers of conducting rubber
- E Layer of conducting rubber plus two layers of synthetic rubber
- F-1 Teflon (solid)
- F-2 Teflon (semi-solid or taped)
- H Conducting synthetic rubber
- J Insulating Butyl-rubber

NOTE 1. Requirements for listed cables are in Specification MIL-C-17.

2/ Jacket types:

- I. Polyvinyl chloride (colored black)
- IIa. Noncontaminating synthetic resin
- IIIa. Noncontaminating synthetic resin (colored black)
- IV. Chloroprene
- V. Fiberglass, silicone-impregnated varnish
- VII. Polytetrafluoroethylene
- VIII. Polyethylene
- IX. Fluorinated ethylene propylene

GUIDE TO SELECTION OF PREFERRED RF CABLES
(See "RF Cable list" for more details, page 2)

Applica- tion	Group	Ohms	Braid	Temper- ature	Not Armored			Armored		
					MIL-C-17 Slash No.	RG No.	Jacket Diam.	MIL-C-17 Slash No.	RG No.	Jacket Diam.
↑ GENERAL PURPOSE ↓	I	50	Single	Low	119	174	.100	76	215	.475
					54	122	.160			
					28	58C	.195			
					74	213	.405			
					79	218	.870			
	81	220	1.120	82	221	1.195				
	II	50	Double	Low	84	223	.216	85	224	.615
					73	212	.332			
					75	214	.425			
					78	217	.545			
					79	177	.870			
III	50	Single	High	93	178B	.075	66	166	.460	
				113	316	.102				
				111	303	.170				
				65	165	.410				
				72	211A	.730				89
IV	50	Double	High	60	142B	.195	88	227	.490	
				112	304	.280				
				92	115	.415				
				127	393	.390				
				52	119	.465				
				107	280	.493				
				87	226	.500				
				108	281	.750				53
V	75	Single	Low	29	59B	.242	7	12A	.475	
				6	11A	.405				
				24	34B	.630				
				64	164	.870				25
VI	75	Double	Low	2	6A	.332	126	392	.475	
				77	216	.425				
VII	75	Single	Low	126	391	.405				
				94	179B	.100				
VIII	93	Single	High	110	302	.206	36	79B	.475	
				62	144	.410				
				30	62A	.242				
				100	133A	.405				
IX	95	Single	Low	31	63B	.405				
				47	114A	.405				
				90	71B	.250				
X	93	Double	Low	95	180B	.145				
				97	210	.242				
Delay Lines .042μ spc/ft	XI	950	--	--	34	65A	.405			

MIL-HDBK-216
SECTION 2A
10 March 1972

Appli- cation	Group	Ohms	Braid	Temper- ature	Not Armored			Armored		
					MIL-C-17 Slash No.	RG No.	Jacket Diam.	MIL-C-17 Slash No.	RG No.	Jacket Diam.
High Atten- uation 90 dB/ 100 ft 116 dB/ 100 ft	XII	50	--	--	109	301	.245			
					83		222			
PULSE	XIII	48	Single	--			.425 .595	21 22	26A 27A	.505 .670
	XIV	48	Double	--	33	64A	.474			
PULSE TRIAX- IAL	XV	48	Single	--	19	25A	.505			
					23	28B	.735 (or .750)			
	XVI	75	Single	--	116	307A	.270			
	XVII	50	Double	--	101	156	.540			
125					329	.700				
				102	157	.725				
XVIII	25	Double	--	103	158	.725				
				124	328	1.205				
TWIN	XIX	78	Single	--	45	108A	.235	57	131	.710
		95			56	130	.625			
DUAL	XX	95	Double	--	15	22B	.420	46	111A	.490
		125			16	23A	.945			

MIL-HDBK-216
SECTION 2A
18 May 1965

ATTENUATION OF STANDARD R.F. CABLES
VS
FREQUENCY

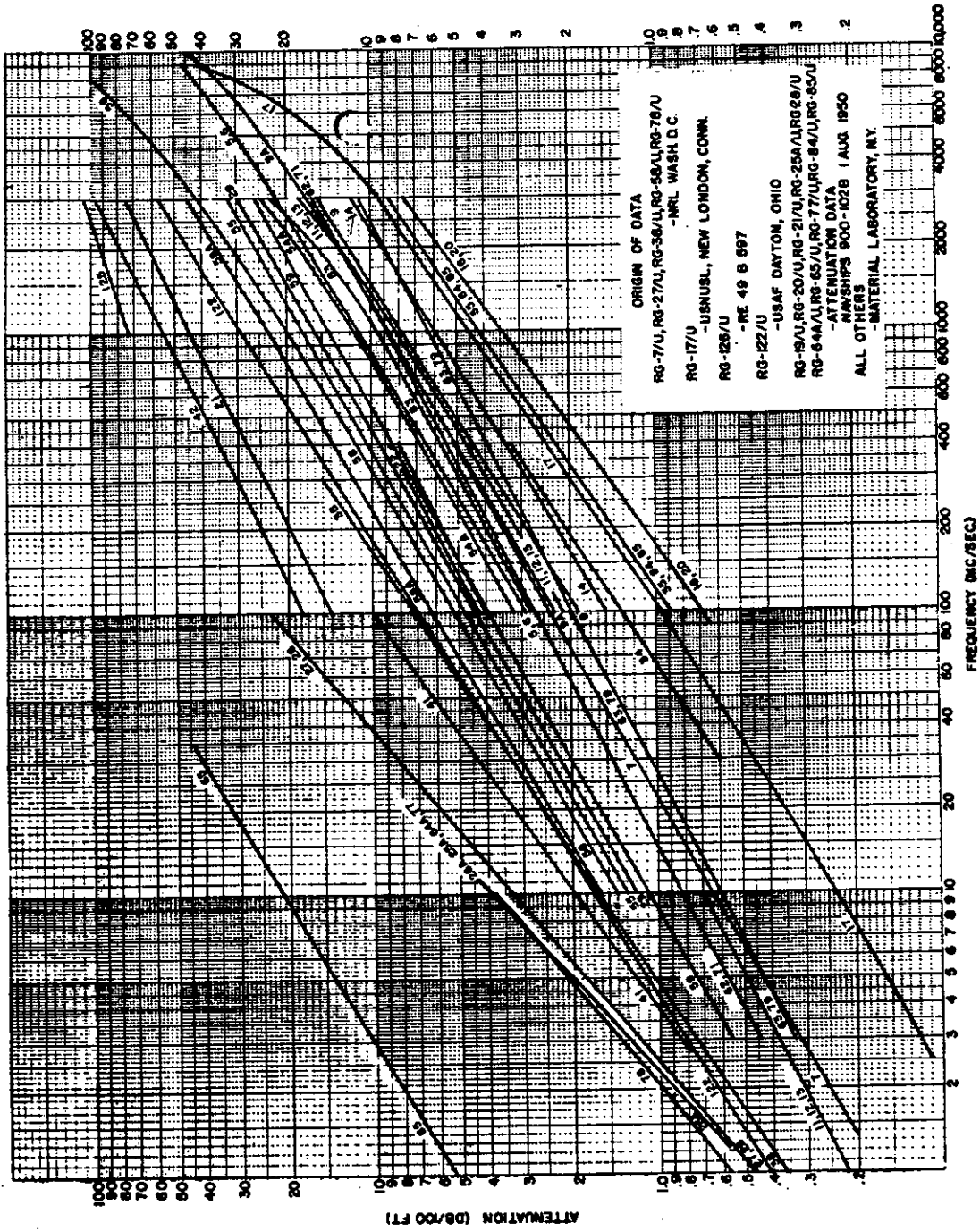

MIL-HDBK-216
SECTION 2A
18 May 1965

ATTENUATION OF STANDARD R.F. CABLES VS FREQUENCY (CONT)

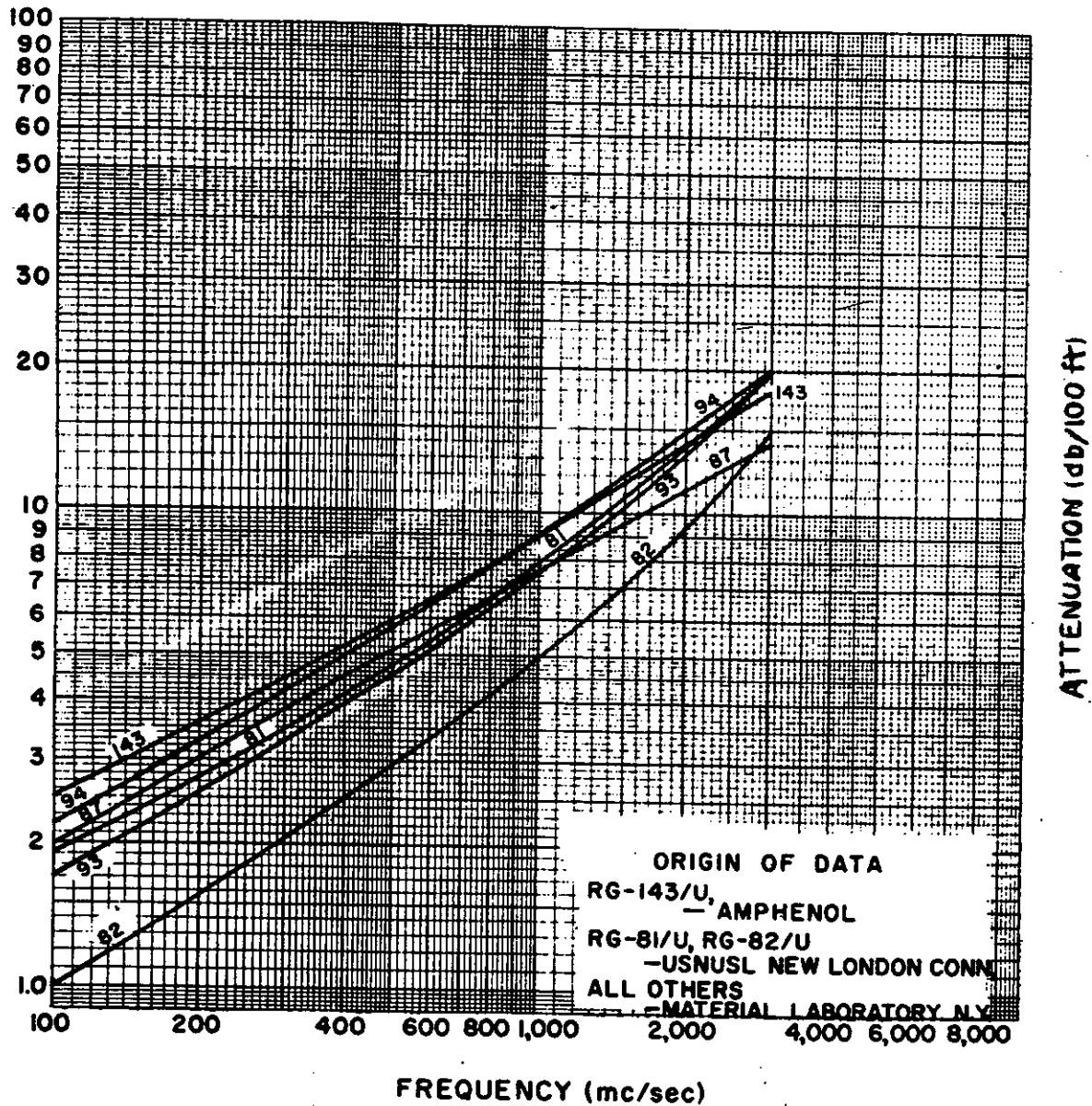

MIL-HDBK-216
SECTION 2A
18 May 1965

ATTENUATION OF STANDARD R.F. CABLES VS FREQUENCY

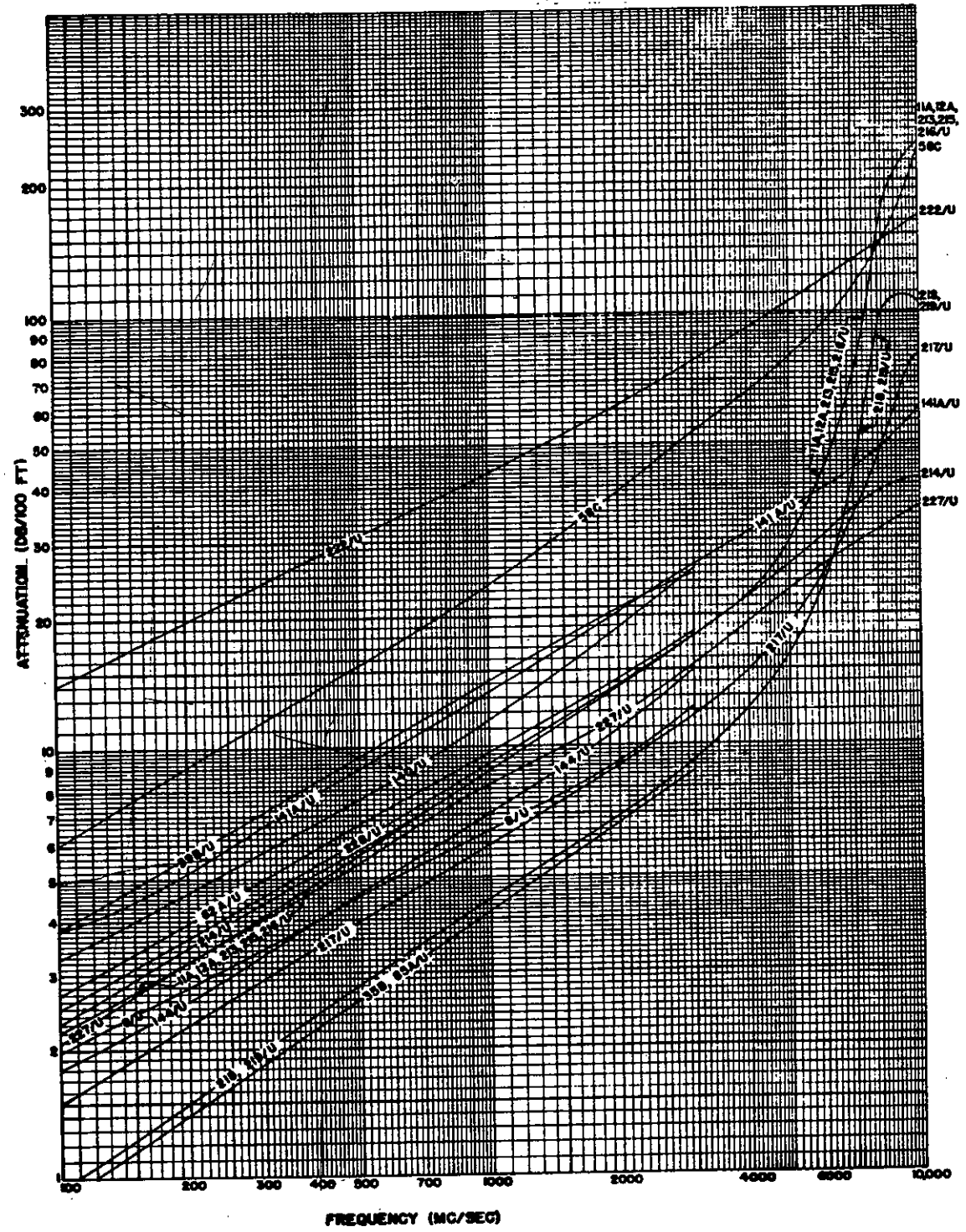

MIL-HDBK-216
 SECTION 2A
 18 May 1965

ATTENUATION VS FREQUENCY
 FOR VARIOUS TYPES OF TRANSMISSION LINES

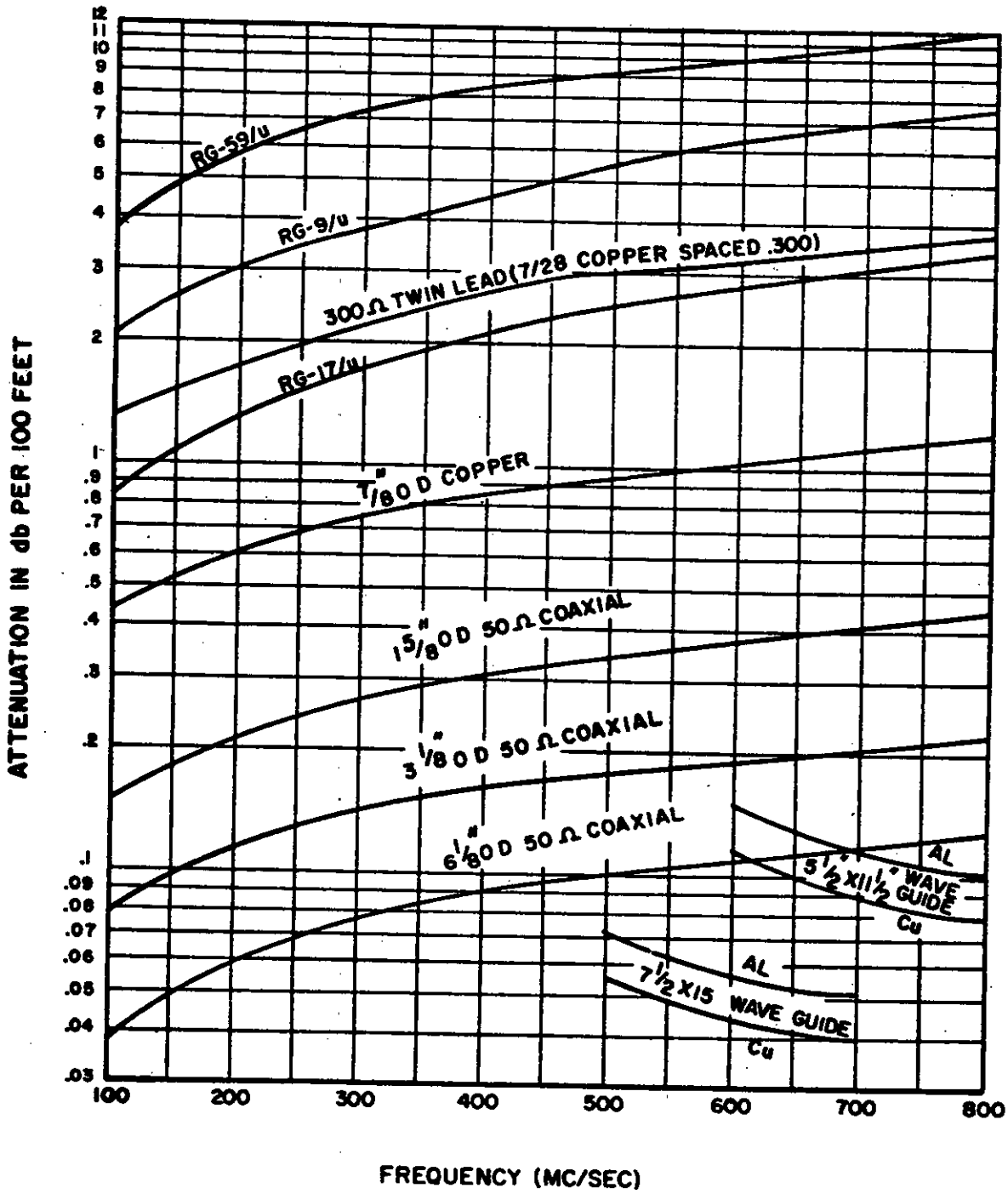

MIL-HDBK-216
SECTION 2A
18 May 1965

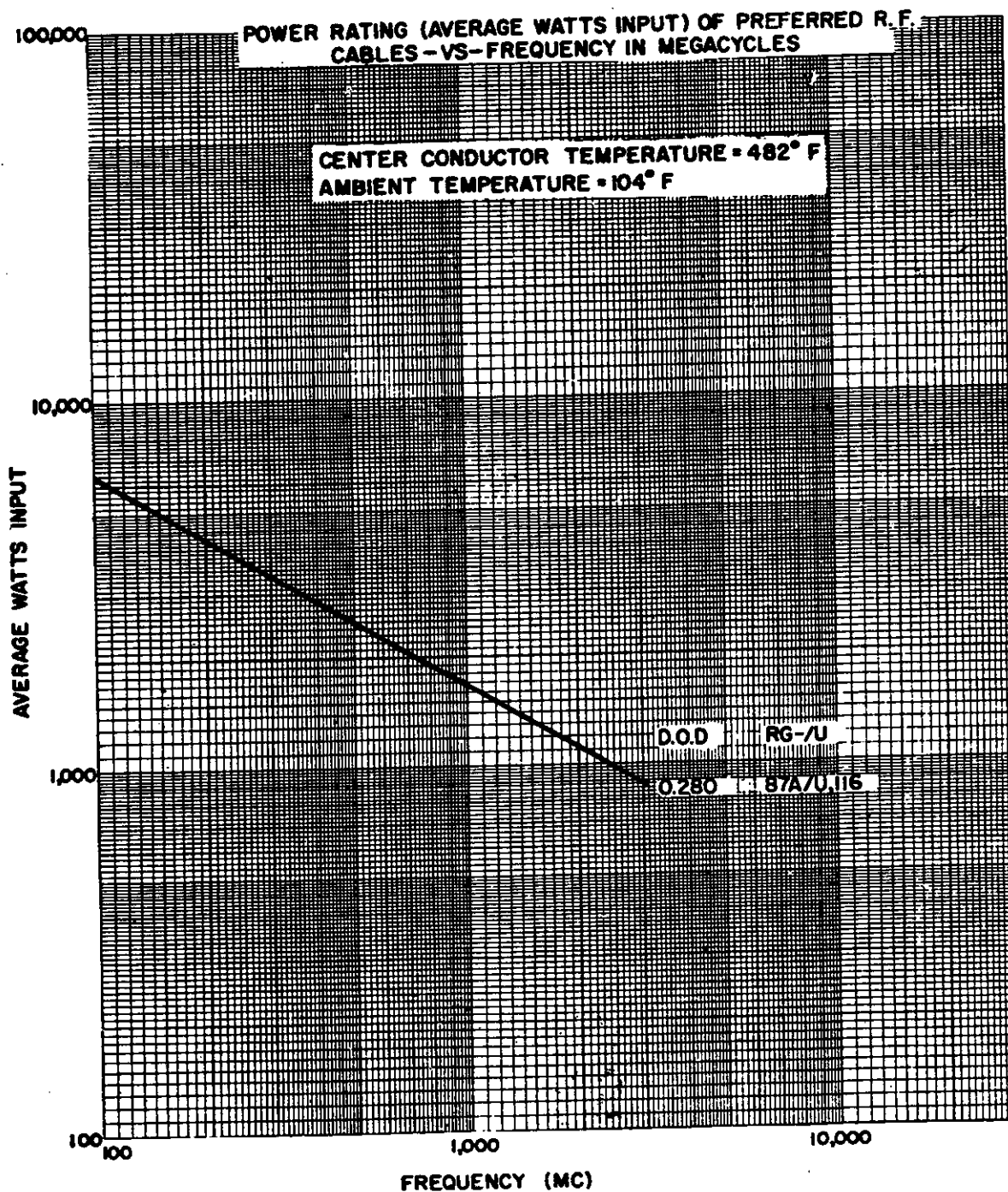

MIL-HDBK-216
SECTION 2A
18 May 1965

POWER RATING (AVERAGE WATTS INPUT)
OF STANDARD R.F. CABLES
VS
FREQUENCY IN MEGACYCLES

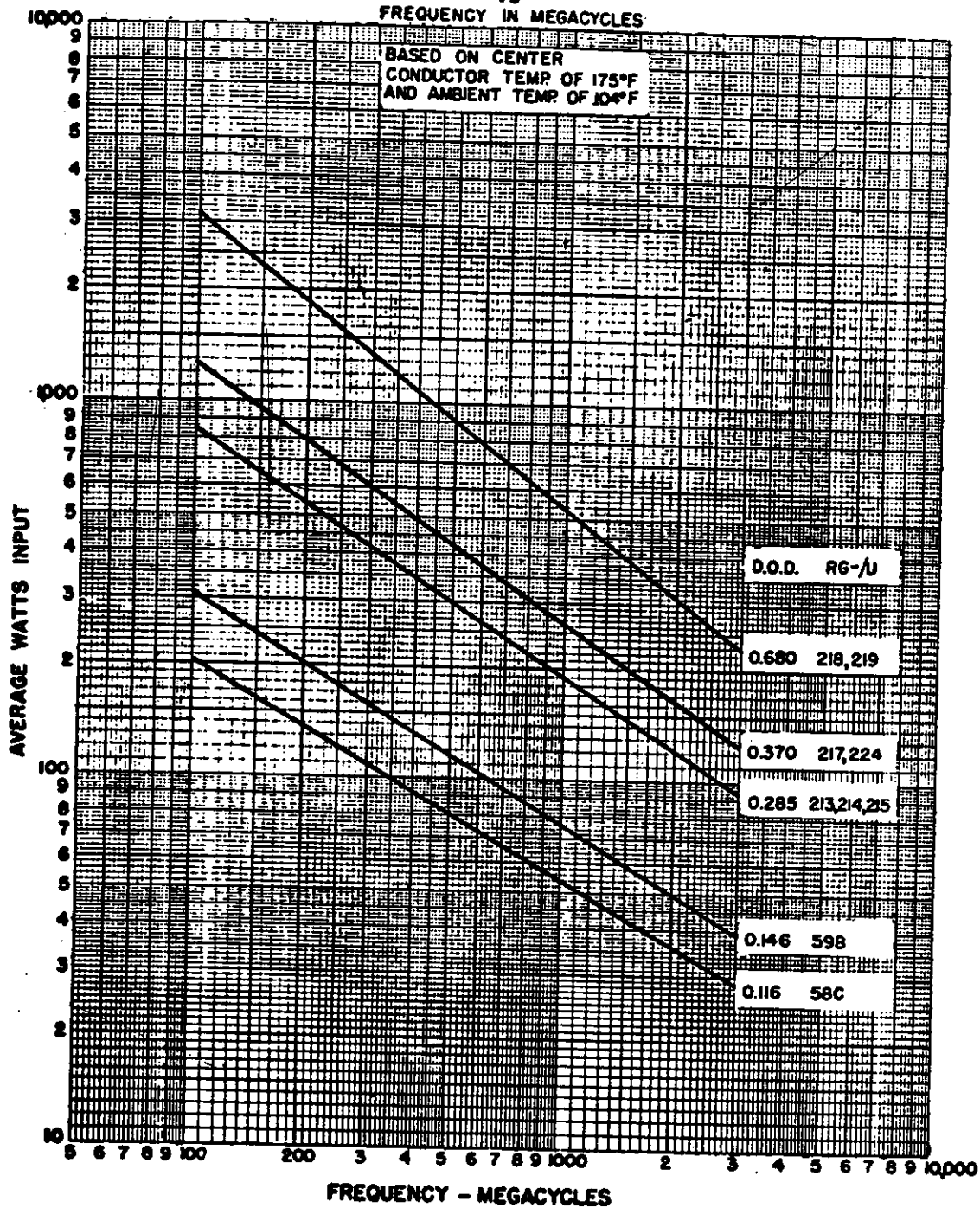

MIL-HDBK-216
SECTION 2A
18 May 1965

ATTENUATION VS FREQUENCY

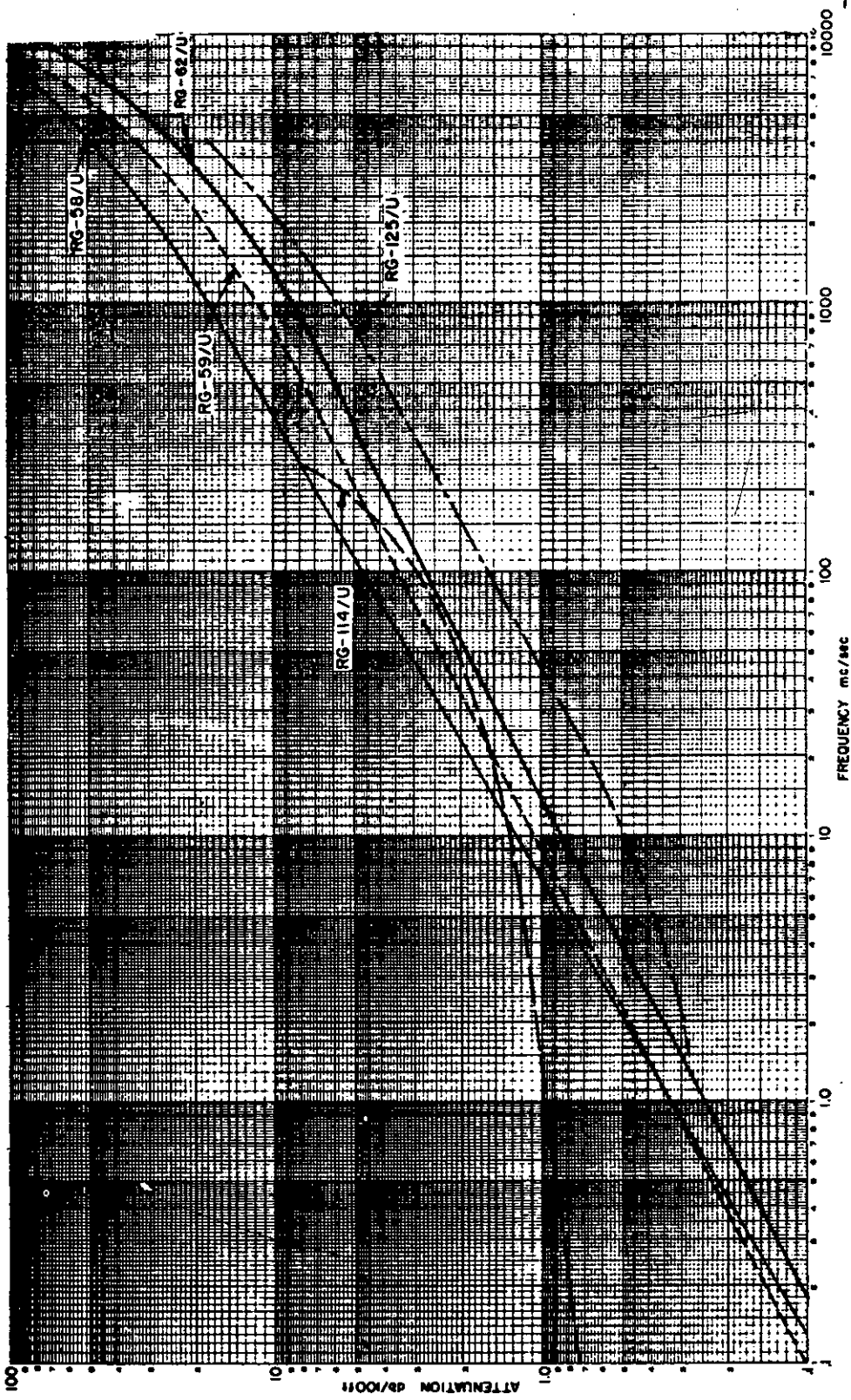

MIL-HDBK-216
SECTION 2A
18 May 1965

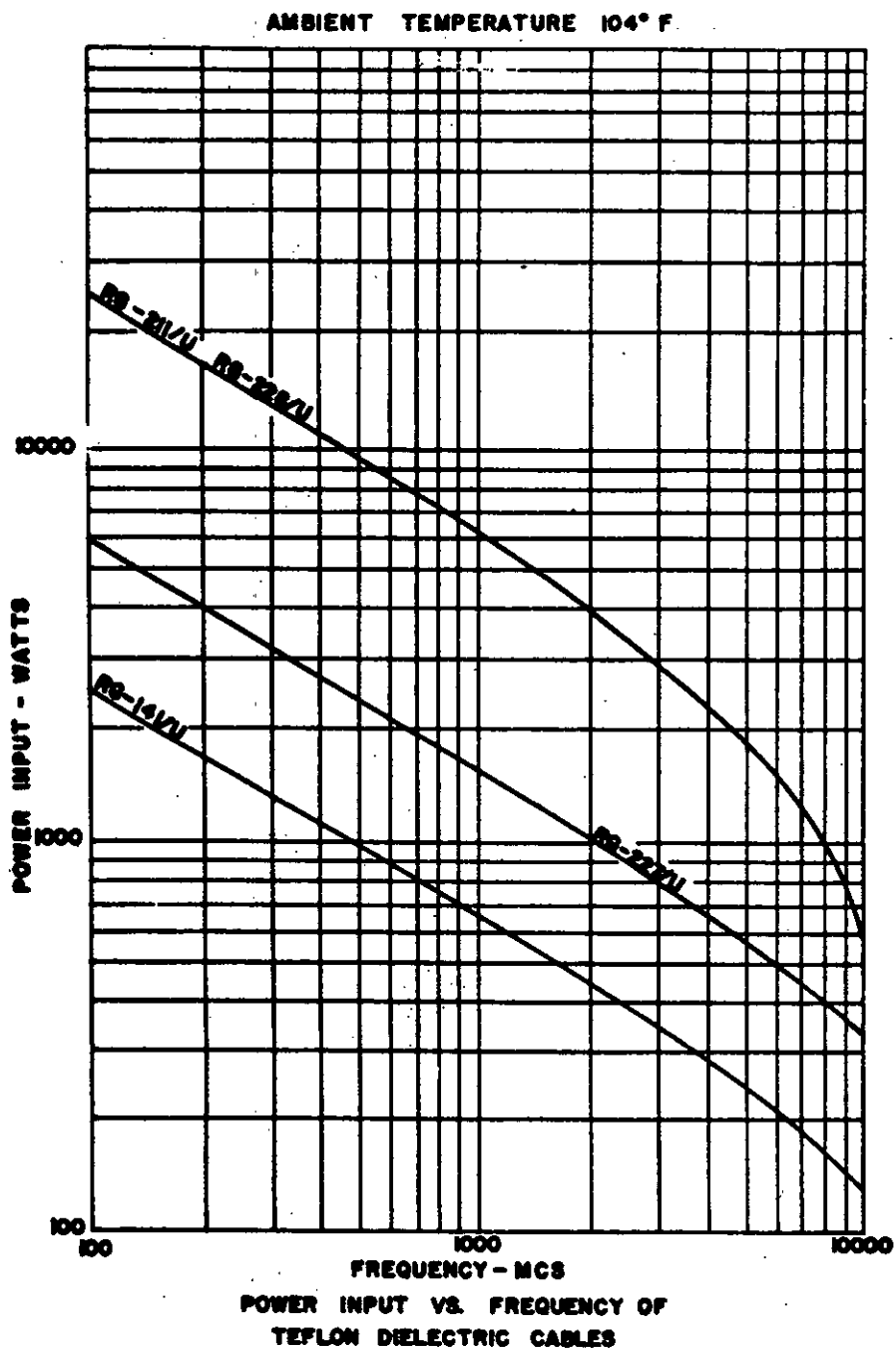

MIL-HDBK-216
SECTION 2A
10 March 1972

SOLID DIELECTRIC R. F. CABLES, FLEXIBLE

Type	Inner conductor	Dielectric material 1/	Nominal diameter of dielectric	Number and type of shields, braid	Protective covering 1/	Nominal Overall diameter	Weight	Nominal impedance	Nominal capacitance	Maximum operating voltage	Engineering data
RG-4/U	20 AWG copper	A	inch	Copper double braid	J	inch	LW/l	Ohms	microfarads	Volts (rms)	Replaced by RG-581C/U
RG-5B/U	14 AWG silver-coated copper	A	0.181	Silver-coated copper double braid	IIa	0.328	0.087	50.0	28.5	3,000	For replacement purposes only; see RG-212/U
RG-6A/U	0.0285 inch copper-covered steel	A	0.185	Silver-covered copper inner; copper outer double braid	IIa	0.332	0.082	75.0	20.0	2,700	
RG-7/U	19 AWG copper	A	0.250	Copper single braid	I	0.370	0.080	95.0	12.5	1,000	Replaced by RG-43B/U
RG-8A/U	7/0.0285 in. copper	A	0.285	Copper single braid	IIa	0.405	0.106	52.0	29.5	5,000	For replacement only. For new design see RG-213/U
RG-9B/U	7/0.0285 in. silver-covered copper	A	0.280	Silver-covered copper double braid	IIa	0.420	0.150	50.0	30.0	5,000	For replacement only. For new design see RG-214/U
RG-10A/U	7/0.0285 in. copper	A	0.285	Copper single braid	IIa with armor	0.475 (max)	0.144	52.0	29.5	5,000	For replacement only. For new design see RG-215/U
RG-11A/U	7/0.0159 in. tinned copper	A	0.285	Copper single braid	IIa	0.405	0.096	75.0	20.5	5,000	
RG-12A/U	7/0.0159 in. tinned copper	A	0.285	Copper single braid	IIa with armor	0.475 (max)	0.141	75.0	20.5	5,000	
RG-13A/U	7/0.0159 in. tinned copper	A	0.280	Copper double braid	IIa	0.420	0.126	74.0	20.5	5,000	For replacement only. For new design see RG-216/U
RG-14A/U	10 AWG copper	A	0.370	Copper double braid	IIa	0.545	0.216	52.0	29.5	7,000	For replacement only. For new design see RG-217/U
RG-15/U	15 AWG copper-covered steel	A	0.370	Copper double braid	I	0.545	0.197	76.0	20.0	5,000	
RG-16/U	0.125 inch copper tube	A	0.460	Copper single braid	I	0.630	0.254	52.0	29.5	6,000	
RG-17B/U				CANCELLED	REASSIGNED NEW NOMENCLATURE	RG-177/U			RG-17A/U		Replaced by RG-218/U
RG-18A/U	0.188 inch copper	A	0.640	Copper single braid	IIa with armor	0.945 (max)	0.585	52.0	29.5	11,000	For replacement only. For new design see RG-219/U
RG-19A/U	0.250 inch copper	A	0.910	Copper single braid	II	1.120	0.740	52.0	29.5	14,000	For replacement only. For new design see RG-220/U
RG-20A/U	0.250 inch copper	A	0.910	Copper single braid	IIa with armor	1.195 (max)	0.925	52.0	29.5	14,000	For replacement only. For new design see RG-221/U
RG-21A/U	0.0508 inch resistance wire	A	0.185	Silver-covered copper double braid	IIa	0.332	0.087	53.0	29.0	2,700	For replacement only. For new design see RG-222/U
RG-22B/U	2-conductors 7/0.0152 inch each copper	A	0.285	Tinned copper double braid	IIa	0.420	0.151	95.0	16.0	1,000	Balanced cable. Tinned conductor.
RG-23A/U	2-conductors 7/0.0285 inch copper	A each core	0.380 each core	Individual inner, common outer, copper	IIa	0.650 ± 0.945	0.490	125.0	12.0	3,000	Dual coaxial cable.

Supersedes page 219
of 18 May 1965

219

MIL-HDBK-216
SECTION 2A
10 March 1972

SOLID DIELECTRIC R. F. CABLES, FLEXIBLE (Continued)

Type	Insulation conductor	Dielectric material	Nominal diameter of dielectric	Number and type of shielding braid	Protective covering	Nominal Overall diameter	Weight	Nominal impedance	Nominal capacitance	Maximum operating voltage	Engineering data
RG-34A/U	3-conductor 70/0285 inch copper	A each wire	inch 0.580 each wire	Individual inner, copper outer, copper	Rs with armor	inch 0.735 + 1.034 (max)	Lb/ft 0.670	Ohms 125.0	nan/ft 12.0	Volts (rms) 3,000	Dual coaxial cable.
RG-25A/U	1995.0117 inch tinned copper	E	0.288	Tinned copper double braid	IV	0.505	0.20*	48.0	50.0	8,000 (peak)	Pair cable.
RG-26A/U	1995.8217 inch tinned copper	E	0.288	Tinned copper single braid	IV with armor	0.505 (max)	0.189	48.0	50.0	8,000 (peak)	Pair cable.
RG-27A/U	1995.9185 inch tinned copper	D	0.455	Tinned copper single braid	IV with armor	0.650 (max)	0.304	48.0	50.0	15,000 (peak)	High voltage. Pair cable.
RG-28B/U	1995.0185 inch tinned copper	D	0.455	Tinned copper inner, galv- nized steel outer, double braid	IV	0.750 for AWG 30 0.735 for AWG 34	0.370	48.0	50.0	15,000 (peak)	High voltage pair cable.
RG-29/U	20 AWG copper	A	0.116	Tinned copper single braid	BE	0.184 (max)	0.021	53.5	28.5	1,900	Replaced by RG-58C/U.
RG-30/U	7/36 AWG copper	B	0.185	Copper single braid	I	0.250		50.0	27.0	1,500	Replaced by RG-54C/U.

MIL-HDBK-216
SECTION 2A
10 March 1972

SOLID DIELECTRIC R. F. CABLES, FLEXIBLE (Continued)

Type	Inner conductor	Dielectric material 1/	Nominal diameter of dielectric	Insulation and type of shielding braid	Protective covering 2/	Nominal Overall diameter	Weight	Nominal impedance	Nominal capacitance	Maximum operating voltage	Engineering data
RG-31/U	7/21 AWG copper	B	0.285	Copper single braid	I	0.405	0.106	51.0	31.0	2,000	Replaced by RG-8A/U.
RG-32/U	7/21 AWG copper	B	0.285	Copper single braid	I with armor	0.465 (max)		51.0	29.0	2,000	Replaced by RG-10A/U.
RG-33/L	10 AWG copper	A	0.370	None	Lead sheath	0.470	0.390	51.0	30.0	6,000	
RG-34B/L	7/0.0249 inch copper	A	0.460	Copper single braid	IIa	0.630	0.224	75.0	21.5	6,500	
RG-35B/L	0.045 inch copper	A	0.680	Copper single braid	IIa with armor	0.945 (max)	0.525	75.0	21.5	10,000	
RG-36/U	0.162 inch copper	A	0.910	Copper single braid	I with armor	1.180	0.805	69.0	22.0	13,000	
RG-37/U	20 AWG tinned copper	C	0.140	Tinned copper single braid	III	0.210 (max)	0.040	52.5	38.0	750	Replaced by RG-58C/U
RG-38/U	17 AWG tinned copper	C	0.196	Tinned copper double braid	III	0.312 (max)	0.110	52.5	38.0	1,000	Replaced by RG-58/U
RG-39/U	22 AWG tinned copper-covered steel	C	0.196	Tinned copper double braid	III	0.312 (max)	0.100	72.5	28.5	1,000	Replaced by RG-4A/U and RG-59B/U
RG-40/U	22 AWG tinned copper-covered steel	C	0.196	Tinned copper double braid	IV	0.420	0.150	72.5	28.5	1,000	Replaced by RG-6A/U
RG-41/L	18/30 AWG tinned copper	C	0.250	Tinned copper single braid	IV	0.425	0.150	87.5	21.6	3,000	
RG-42/L	21 AWG resistor wire	A	0.196	Silver-covered copper double braid	II	0.342	0.056	78.6	20.0	2,700	Replaced by RG-21A/U
RG-43/L	2-conductor 7/21 AWG copper	B	0.472	Copper single braid	I	0.617		93.0	17.6	1,500	Replaced by RG-130/L
RG-54A/L	7/0.0152 inch copper	A	0.178	Tinned copper single braid	III	0.250 (max)	0.041	58.0	26.5	3,000	
RG-55B/L	0.0355 inch silver-covered copper	A	0.116	Tinned copper double braid	IIIa	0.206		53.0	28.5	1,900	Replaced by RG-233/L
RG-56/L	19/0.0177 inch copper	D	0.308	Copper double braid	I	0.535					Special form. Pair cable
RG-57A/U	2-conductor 7/0.0285 inch copper	A	0.472	Tinned copper single braid	IIa	0.625	0.225	93.0	17.0	3,000	Two conductor. Replaced by RG-130/L
RG-58C/L	19/0.0071 inch tinned copper	A	0.116	Tinned copper single braid	IIa	0.195	0.024	50.0	28.5	1,900	
RG-59B/L	8.0230 inch copper-covered steel	A	0.146	Copper single braid	IIa	0.242	0.032	75.0	21.0	2,300	
RG-60/L	Stranded copper	C	0.250	Copper single braid	IV	0.425		50.0			

Supersedes spec 2-20
of 18 May 1965

220

MIL-HDBK-216
SECTION 2A
10 March 1972

SOLID DIELECTRIC R. F. CABLES, FLEXIBLE (Continued)

Type	Inner conductor	Dielectric material 1	Nominal diameter of dielectric	Number and type of shielding braid	Protective covering 2	Nominal Overall diameter	Weight	Nominal impedance	Nominal capacitance	Maximum operating voltage	Engineering data
RG-42A/U	.0253 inch copper-covered steel	A	inch 0.146	Copper single braid	IIIa	inch 0.249	Lb/ft	Ohms 93.0	μF/ft 14.5	Volts (max)	
RG-42B/U	7/32 AWG copper-covered steel	A	0.146	Copper single braid	IIIa	0.242	0.0283	93.0	14.5	750	
RG-43B/U	0.0253 inch copper-covered steel	A	0.285	Copper single braid	IIIa	0.405	0.0832	125.0	11.0 (max)	1.00kV	Low capacitance
RG-64/U	19/0.017 inch tinned copper	D	0.318 (max)	Tinned copper double braid	IV	0.495		48.0			Replaced by RG-64A/U
RG-64A/U	19/0.017 inch tinned copper	E	0.288	Tinned copper double braid	IV	0.475 (max)	0.205	48.0	50.0	8.00kV (peak)	Phase cable
RG-65A/U	32 AWG Formosa F. Nylon woven Diameter (Held) 0.128 inch	A	0.285	Copper single braid	IIIa	0.405	0.096	950.0	44.0	1.00kV	High impedance delay line, video cable
RG-71B/U	0.0253 inch copper-covered steel	A	0.146	Tinned copper double braid	IIIa	0.250	0.0457	93.0	14.5 (max)	750	

MIL-HDBK-216
SECTION 2A
10 March 1972

SOLID DIELECTRIC R. F. CABLES, FLEXIBLE (Continued)

Type	Inner conductor	Dielectric material Δ	Nominal diameter of dielectric Inch	Number and type of shielding braid	Protective covering Δ	Nominal Overall diameter Inch	Weight Lb/ft	Nominal spaced area Ohms	Nominal capacitance pF/ft	Maximum operating voltage Volts (rms)	Engineering data
RG-72/U	22 AWG copper-covered steel	A	0.460	Copper single braid	I	0.630		150.0			
RG-73/U	20 AWG copper	A	0.116	Copper double braid	Copper braid	0.275		23.0			
RG-74A/U	0.102 inch copper	A	0.370	Copper double braid	IIa with armor	0.615 (max)	0.310	52.0	29.5	7,000	For replacement only; for new design use RG-224/U
RG-77A/U	19/0.0117 inch tinned copper	E	0.285	Tinned copper double braid	IIa	0.450 (max)		48.0	50.0	8,000 (peak)	Plastic cable
RG-78A/U	19/0.0117 inch tinned copper	E	0.285	Tinned copper single braid	IIa	0.420 (max)		48.0	50.0	8,000 (peak)	Same as RG-74A/U except has single braid
RG-79B/U	0.0253 inch copper covered steel	A	0.285	Copper single braid	IIa with armor	0.475 (max)	0.130	125.0	11.0 (max)	1,000	RG-43B/U with armor
RG-81/U	0.0625 inch copper	G	0.321	None	Copper tube	0.575	0.172	50.0	37.0	3,000	Semi-rigid high temperature
RG-82/U	0.125 inch	C	0.650	None	Copper tube	0.750	0.498	50.0	36.0	5,000	Semi-rigid high temperature
RG-83/U	10 AWG copper	A	0.240	Copper single braid	I	0.405		35.0	44.0	2,000	
RG-84A/U	0.1045 inch copper	A	0.680	Copper single braid	IIa with lead sheath	1.000	1.325	75.0	21.5	10,000	RG-33B/U with lead sheath in lieu of armor
RG-85A/U	0.1045 inch copper	A	0.680	Copper single braid	IIa with lead sheath and special armor	1.565 (max)	2.910	75.0	21.5	10,000	RG-84A with special armor
RG-86/U	2-conductor 7/0.0285 inch soft copper	A	0.650 & 0.300	None	None	0.650 & 0.300		200.0	7.8		Twist lead CANCELLED
RG-87A/U	7/0.032 inch silver covered copper	F	0.280	Silver covered copper double braid	V	0.425		50.0	29.5	5,000	For replacement only; for new design use RG-225/U
RG-88/U	19/0.0117 inch tinned copper	E	0.285	Tinned copper four braid	I	0.515		48.0	50.0	8,000	Plastic
RG-88A/U	19/0.0117 inch tinned copper	E		Tinned copper four braid	II	0.515		50.0	50.0	8,000	
RG-88B/U	19/0.0117 inch tinned copper	E	0.285	Tinned copper four braid	IV	0.565		50.0		10,000	
RG-89/U	22 AWG copper covered steel	A	0.285	Copper single braid	I	0.632		125.0	10.0	1,000	Low capacitance
RG-90/U	7/24 AWG silver covered copper	A	0.195	Silver coated copper, galvanized steel, silver coated copper, 3 braids	IIa	0.425		30.0	30.5	3,000	Carrier frequency communication

MIL-HDBK-216
SECTION 2A
10 March 1972

SOLID DIELECTRIC R. F. CABLES, FLEXIBLE (Continued)

Type	Inner conductor	Dielectric material 1	Nominal diameter of dielectric	Number and type of shielding braid	Protective covering 2	Nominal Overall diameter	Weight	Nominal impedance	Nominal capacitance	Maximum operating voltage	Engineering data
RG-93/U	19#L040 inch copper	F-2	inch 0.574	Copper single braid	V	inch 0.710	Lb/ft 0.475	Ohms 50.0	picfarads 29.0	Volts (rms) 10,000	Replaced by RG-117A/U
RG-94/U	19#L0225 inch 60mil covered copper	F-2	0.292	Copper double braid	V	0.445		50.0	27.0	7,000	For replacement only. For new design use RG-226/U
RG-100/U	19#L0147 inch copper	A	0.146	Copper single braid	I	0.242		35.0	44.0	2,000	
RG-108A/U	3-conductor 7/28 AWC inch tin-plated copper	A	0.079 each core	Tinned copper single braid	IIa	0.235		78.0	24.5 (max)	1,000	Shielded twisted pair

MIL-HDBK-216
SECTION 2A
10 March 1972

SOLID DIELECTRIC R. F. CABLES, FLEXIBLE

Type	Inner conductor	Dielectric material Δ	Nominal diameter of dielectric	Number and type of shielding braid	Protective covering Δ	Nominal Overall diameter	Weight	Nominal impedance	Nominal capacitance	Maximum operating voltage	Engineering data
RG-111A/U	2-conductor 7/0.0152 inch nich copper	A semi-solid	0.285	Tinned copper double braid	IIa with armor	0.490 (max)	0.146	95.0	16.0	1,000	
RG-114A/U	0.007 inch copper covered steel	A semi-solid	0.285	Copper single braid	IIa	0.405		185.0	6.8 (max)	1,000	Special low capacitance
RG-115/U	7/0.028 inch silver covered copper	F-2	0.250	Silver covered copper double braid	V	0.375		50.0		4,000	Replaced by RG-115A/U
RG-115A/U	7/28 AWG silver covered copper	F-2	0.255	Silver covered copper double braid	V	0.415		50.0	29.5	4,000	
RG-116/U	7/0.032 inch silver covered copper	F-1	0.280	Silver covered copper double braid	V with armor	0.475 (max)	0.224	50.0	29.5	5,000	For replacement only. For new design use RG-227/U
RG-117A/U	0.184 inch copper	F-1	0.420	Copper single braid	V	0.730	0.450	50.0	29.5	7,000	Same as RG-117/U except for braid. For new design use RG-211A/U.
RG-118A/U	0.188 inch copper	F-1	0.420	Copper single braid	V with armor	0.780	0.610	50.0	29.5	7,000	Same as RG-118/U except for braid. For new design use RG-228A/U.
RG-119/U	0.102 inch copper	F-1	0.332	Copper double braid	V	0.465	0.225	50.0	29.0	6,000	High temperature
RG-120/U	0.102 inch copper	F-1	0.332	Copper double braid	V with armor	0.525 (max)	0.282	50.0	29.0	6,000	Same as RG-119/U with armor
RG-122/U	27/34 AWG tinned copper	A	0.096	Tinned copper single braid	IIa	0.160	0.020	50.0	29.5	1,900	
RG-124/U	22 AWG tinned copper covered steel	F-2	0.135	Tinned copper single braid	V	0.240		75.0	20.5	2,300	Replaced by RG-302/U
RG-125/U	26 AWG copper covered steel	A semi-solid	0.460	Copper single braid	IIa	0.600		150.0	7.8	2,000	Special low capacitance
RG-126/U	7/0.0203 inch karma wire	F-1	0.185	Karma wire single braid	V	0.280		50.0	29.0	3,000	Replaced by RG-301/U
RG-130/U	2-conductor 7/0.0285 inch copper	A	0.472	Tinned copper single braid	I	0.625		95.0	17.6	8,000	Same as RG-57A except inner conductor are treated for improved flexibility.
RG-131/U	2-conductor 7/0.0285 inch copper	A	0.472	Tinned copper single braid	I with aluminum armor	0.710 (max)		95.0	17.0	8,000	Same as RG-130/U except for armor
RG-133A/U	22 AWG copper	A	0.285	Copper single braid	IIa	0.405		95.0	16.2	4,000	NATO Type MWR7
RG-140/U	0.025 inch silver covered copper covered steel	F-1	0.146	Silver covered copper single braid	V	0.233		75.6	21.6	2,300	CANCELLED High temperature similar to RG-59A/U. Same as RG-302/U with FEP jacket. Use RG-302/U
RG-141A/U	0.039 inch silver covered copper covered steel	F-1	0.116	Silver covered copper single braid	V	0.190		50.0	28.5	1,900	CANCELLED High temperature similar to RG-58C/U. Same as RG-303/U with FEP jacket. Use RG-303/U

Supersedes Page 2-22
of 18 Mar 1965

2-22

MIL-HDBK-216
SECTION 2A
10 March 1972

SOLID DIELECTRIC R. F. CABLES, FLEXIBLE (Continued)

Type	Inner conductor	Dielectric material	Nominal diameter of dielectric	Number and type of shielding braid	Protective covering	Nominal Overall diameter	Weight	Nominal impedance	Nominal capacitance	Maximum operating voltage	Engineering data
RG-142A/U	0.039 inch silver covered copper covered steel	F-1	Inch 0.116	Silver covered copper double braid	V	Inch 0.206	LB/ft	Ohms 50.0	mf/ft 28.5	Volts (rms) 1,900	High temperature similar to RG-55A/U
RG-142B/U	0.039 inch silver covered copper covered steel	F-1	0.116	Silver covered copper double braid	IX	0.195		50.0	28.5		
RG-143A/U	0.059 inch silver covered copper covered steel	F-1	0.185	Silver covered copper double braid	V	0.325		50.0	28.5	3,000	CANCELLED High temperature similar to RG-55A/U. Same as RG-304/U with FEP jacket. Use RG-304/U

MIL-HDBK-216
SECTION 2A
10 March 1972

SOLID DIELECTRIC R. F. CABLES, FLEXIBLE (Continued)

Type	Inner conductor	Dielectric material 1/	Nominal diameter of dielectric	Number and type of shielding braid	Protective covering 3/	Nominal Overall diameter	Weight	Nominal impedance	Nominal capacitance	Maximum operating voltage	Engineering data
			Inch			Inch	Lb/ft	Ohms	pic/ft	Volts (rms)	
RG-144/U	7/0.0179 inch silver covered copper covered steel	F-1	0.285	Silver covered copper single braid	V	0.410		75.0	20.5	5,000	High temperature similar to RG-11A/U
RG-146/U				CANCELLED							
RG-147/U	Single conductor copper 0.250	A		Copper single braid	I Waterproof zinc steel with armor	1.937		52.0	29.5	14,000	RG-19A/U with armor
RG-148/U	7/21 AWG copper	A		Copper single braid	I Waterproof zinc steel with armor	0.800		52.0	29.5	4,000	RG-8A/U with spiral armor
RG-149/U	7/26 AWG tinned copper	A	0.285	Copper single braid	I	0.405		75.0	20.5	5,000	Replaced by RG-391/U
RG-150/U	7/26 AWG tinned copper	A	0.285	Copper single braid	I with armor	0.475 (max)		75.0	20.5	5,000	Replaced by RG-392/U
RG-156/U	7/21 AWG tinned copper	A-H	2/0.285	Three braids, tinned copper	IIa	0.540	0.211	50.0	30.0	10,000	Taped inner layer, 1. Type E and I Type A-D, between 2nd braid of outer conductor and braided tinned copper shield. Pulse cable.
RG-157/U	19/24 AWG tinned copper	H-A-H	3/0.455	Galv. steel tinned copper	IIa	0.725	0.317	50.0	38.0	15,000	
RG-158/U	37/21 AWG	H-A-H	3/0.455		IIa	0.725	0.380	25.0	78.0	15,000	
RG-159/L	20 AWG silver covered copper	F-2		Silver covered copper single braid	V	0.195		50.0	29.0	2,300	High temperature equivalent of RG-55A/U. Replaced by RG-142B/U
RG-160A/U	4-conductor 19/27 AWG 2-copper 2-tinned copper	A	0.322	Copper single braid	IIIa	1.055		125.0	12.0	3,000	Same as RG-160/U except copper ribbon braid and nylon tape
RG-161/U	7/38 AWG silver plated cadmium bronze	F-1	0.057	Silver covered copper single braid	Extruded black nylon	0.090 (max)		70.0	20.0	1,000	Minimum CANCELLED
RG-164/L	0.1045 inch copper	A	0.680	Copper single braid	IIa	0.870	0.490	75.0	21.0	10,000	Same as RG-35B/U except nylon
RG-165/U	7/0.032 inch silver covered copper	F-1	0.285	Silver covered copper single braid	V	0.410	0.121	50.0	29.5	5,000	
RG-166/U	7/0.032 inch silver covered copper	F-1	0.285	Silver covered copper single braid	V with armor	0.460	0.1438	50.0	29.5	5,000	Same as RG-165/U except armored
RG-174/L	7/34 AWG copper covered steel	A	0.060	Tinned copper single braid	A	0.100		50.0	30.4	1,500	
RG-176/U	0.135 inch copper M55s wound over magnetic core	A	0.285	Copper wound over core, single braid	A	0.405		2400	49	2,000	High impedance delay line

Supersedes page 2.23
of 18 May 1965

2.23

MIL-HDBK-216
SECTION 2A
10 March 1972

SOLID DIELECTRIC R. F. CABLES, FLEXIBLE (Continued)

Type	Inner conductor	Dielectric material \checkmark	Nominal diameter of dielectric	Number and type of shielding braid	Protective covering \checkmark	Nominal Over-all diameter	Weight	Nominal impedance	Nominal capacitance	Maximum operating voltage	Engineering data
RG-177/U	0.195 inch copper	A	inch 0.680	Silver covered copper double braid	Ba	inch 0.895	Lb/ft. 0.470	Ohms 50.0	picofarads 100/ft	Volts (rms) 11,000	
RG-178/U	70.004 inch silver covered copper covered	F-1	0.034	Silver covered copper single braid	IX	0.075 (max)		50.0	29.0	1,000	
RG-179/U	70.004 inch silver covered copper covered steel	F-1	0.063	Silver covered copper single braid	IX	0.105 (max)		75.0	20.0	1,200	

MIL-HDBK-216
SECTION 2A
10 March 1972

SOLID DIELECTRIC R. F. CABLES, FLEXIBLE (Continued)

Type	Inner conductor	Dielectric material 2/	Nominal diameter of dielectric	Number and type of shielding braid	Protective covering 3/	Nominal Overall diameter	Weight	Nominal impedance	Nominal capacitance	Maximum operating voltage	Engineering data
RG-180B/U	7/16 inch silver-covered copper covered steel	F-1	0.102	Silver covered copper single braid	IX	0.145 (max)	Lb/ft	Ohms 95.0	15.5 pF/ft	1,500 Volts (rms)	
RG-181/U	3-conductor 7/32 AWC copper	A each core	0.210 each core	Copper, individual inner, copper shield	IIa	0.640		125.0	12	3,500	CANCELLED
RG-182/U	4-conductors 2-19/10.0142 2-19/10.0066 2-copper 2-iron-copper	A each core	2-0.322 2-0.146	4-copper single braids 1-copper common	IIa each 1 common inner and outer	1.055		125.0 each central	12 each central	2,300 and 3,000	Special, dual termin
RG-185/U	0.0031 inch woven unshielded magnet wire, Methyl over Poly. core	A semi-solid	0.188	Magnet wire single braid	IIa	0.282 (max)		2,000			Delay cable
RG-186/U	0.0061 inch tetraon insulated magnet wire, Methyl over core	A semi-solid	0.292	Magnet wire single braid	IIa	0.405		1,000			Delay cable
RG-187A/U	7/16 inch silver covered unshielded copper covered steel	F-1	0.060 (max)	Silver covered copper single braid	VII	0.110		75.0		1,200	CANCELLED Same as RG-187/U except unshielded inner conductor Use RG-179B/U
RG-188A/U	7/16 inch silver covered unshielded copper covered steel	F-1	0.060	Silver covered copper single braid	VII	0.110		50.0		1,200	CANCELLED Same as RG-188/U except unshielded inner conductor Use RG-316/U
RG-189/U	0.251 inch copper	Polystyrene Methyl		Silver covered copper double braid	IIIa	0.875		50.0	23.0	3,500	Replaced by 3C-C45992
RG-190/U	19/10.0117 inch tinned copper	Composite H J	0.380	Tinned copper, galv. steel Tinned copper tetrac braid	VIII	0.700	0.353	50.0	50.0	15,000	CANCELLED
RG-191/U	0.485 inch tinned copper single braid over inner core	Composite H J H	1.065	Tinned copper, inner, Galv. steel outer, double braid	VIII	1.440	1.469	25.0	85.0	15,000	CANCELLED
RG-192/U	1.055 inch Galvanized steel tube tinned copper braid	Composite Butyl rubber		Tinned copper, inner, Galvanized steel outer double braid	Rubber	2.200		12.5	175.0	15,000 (peak)	Pulse cable
RG-193/U	1.055 inch Galvanized steel tube tinned copper braid	Composite silicone tape and butyl rubber		Tinned copper, inner, galvanized steel outer double braid	Rubber	2.100		12.5	159.0	30,000 (peak)	Pulse cable

MIL-HDBK-216
SECTION 2A
10 March 1972

SOLID DIELECTRIC R. F. CABLES, FLEXIBLE (Continued)

Type	Inner conductor	Dielectric material	Nominal diameter of dielectric	Number and type of shielding braid	Protective covering	Nominal Overall diameter	Weight	Nominal impedance	Nominal capacitance	Maximum operating voltage	Engineering data
RG-194/U	1.055 inch Cadmium plated steel tube, inner copper braid	Composite aluminum tape and butyl rubber	inch	Three copper braids; galva- nized steel over	Aluminum armor over rubber	inch 1.945	Lb/ft	Ohms 12.5	uff/ft 159.0	Volt/term 30,000 (Peak)	Pure cable
RG-195A/U	7/0.004 inch silver covered annealed copper covered steel	F-1	0.102	Silver covered copper single braid	VII	0.155		95.0		1,500	CANCELLED Same as RG-195/U except annealed inner conductor Use RG-180B/U
RG-196A/U	7/0.004 inch silver covered annealed copper covered steel	F-1	0.034	Silver covered copper single braid	VII	0.080		50		1,000	Replaced by RG-178B/U

MIL-HDBK-216
SECTION 2A
10 March 1972

SOLID DIELECTRIC R. F. CABLES, FLEXIBLE

Type	Innr conductor	Dielect. material 1/	Nominal diameter of dielect. 2/	Number and type of shielding braid	Protective covering 3/	Nominal Overall diameter	Weight lb/ft	Nominal impedance	Nominal capacitance	Maximum operating voltage	Engineering data
RG-209/U	19/0.0376 inch silver-covered copper	1-2	inch	Silver-covered copper double braid	V1	inch 0.750	lb/ft	Ohms 50.0	pic/f 11	Volts rms 3,200	Replaced by RG-281/U
RG-210/U	0.0253 inch silver-covered copper covered steel	1-1	0.146	Silver-covered copper single braid	V	0.242		93.0		750	Replaces RG-62/U
RG-211A/U	0.190 inch copper	1-1	0.620	Copper single braid	V	0.730		50.0	14.5 (max)	7,000	Same as RG-211/U, except braid wire size and No. ends
RG-212/U	0.556 inch silver-covered copper	A	0.185	Silver-covered copper double braid	IIa	0.332		50.0		3,000	Formerly RG-5B/U
RG-213/U	7/0.0296 inch copper	A	0.285	Copper single braid	IIa	0.405		50.0		5,000	Formerly RG-8A/U
RG-214/L	7/0.0296 inch silver-covered copper	A	0.285	Silver-covered copper double braid	IIa	0.425		50.0		5,000	Formerly RG-9B/U
RG-215/U	7/0.0296 inch copper	A	0.285	Copper single braid	IIa with armor	0.475 (max)		50.0		5,000	Formerly RG-10A/U
RG-216/U	7/0.0159 inch tinned copper	A	0.285	Copper double braid	IIa	0.425		75.0		5,000	Formerly RG-13A/U
RG-217/L	0.106 inch copper	A	0.370	Copper double braid	IIa	0.545		50.0		7,000	Formerly RG-14A/U
RG-218/U	0.195 inch copper	A	0.680	Copper single braid	IIa	0.870		50.0		11,000	Formerly RG-17A/U
RG-219/U	0.195 inch copper	A	0.680	Copper single braid	IIa with armor	0.945 (max)		50.0		11,000	Formerly RG-18A/U
RG-220/U	0.260 inch copper	A	0.910	Copper single braid	IIa	1.120		50.0		14,000	Formerly RG-19A/U
RG-221/U	0.260 inch copper	A	0.910	Copper single braid	IIa with armor	1.195 (max)		50.0		14,000	Formerly RG-20A/U
RG-222/L	0.0256 inch high resistance wire	A	0.185	Silver-covered copper double braid	IIa	0.332	0.004	50.0	29.0	2,700	Formerly RG-21A/U
RG-223/L	0.035 inch silver-covered copper	A	0.116	Silver-covered copper double braid	IIa	0.216	0.036	50.0		1,900	Formerly RG-55A/U
RG-224/L	0.106 inch copper	A	0.370	Copper double braid	IIa with armor	0.415 (max)		50.0		7,000	Formerly RG-74A/U
RG-225/L	7/0.0312 inch silver-covered copper	1-1	0.285	Silver-covered copper double braid	V double braid	0.430		50.0		5,000	Formerly RG-87A/U
RG-226/L	18/0.0254 inch silver-covered copper	1-2	0.370	Copper double braid	V double braid	0.590		50.0		7,000	Formerly RG-94A/U
RG-227/U	7/0.0312 inch silver-covered copper	1-1	0.285	Silver-covered copper double braid	V double braid with armor	0.490		50.0		5,000	Formerly RG-116/U

Supersedes Part 2.25
of 14 May 1965

2.25

NIL-HDBK-216
SECTION 2A
10 March 1972

SOLID DIELECTRIC R. F. CABLES, FLEXIBLE (Continued)

Type	Inner conductor	Dielectric material \checkmark	Nominal diameter of dielectric	Number and type of shielding braid	Protective covering \checkmark	Nominal Over-all diameter	Weight	Nominal impedance	Nominal capacitance	Maximum operating voltage	Engineering data
RG-228A/U	0.190 inch copper	F-1	inch 0.620	Copper single braid	V double braid with armor	inch 0.795 (max)	Lb/ft	Ohms 50.0	μf/ft	Volts (rms) 7,000	Same as RG-228/U except braid wire size and No. ends
RG-229/U					CANCELLED						
RG-230/U	17/0.0284 inch tinned copper	D	0.455	Tinned copper inner. Galvan- neal steel outer double braid	IV	0.740		25.0	18.0		Triaxial style cable CANCELLED Use RG-158/U
RG-235/U	17/0.028 inch silver-covered copper	F-2	0.255	Silver-covered copper double braid	VI	0.470 (max)		50.0	29.0	5,000 (peak)	CANCELLED Use RG-155A/U
RG-264A/U	19/0.0142 inch 2-copper; 2-tinned copper 4-copper cables	A	0.176 each core	2-Copper 2-tinned copper Copper common over braid	Nylon tape each central Polyurethane over the Nylon wrap	0.750		36.8	41.0		Same as RG-264/U except for low temperature. Polyurethane Jacket.
RG-266/U	0.028 AWC wound over steel; insulation spec 0.144	A	0.285	75 spiral wound copper conductors 68 bare 7 insulated	A	0.490		1530.0	53.0	4,000	Data line
RG-279/U	19/0.005 inch tinned copper covered steel	F-2	0.110	Silver-covered copper single braid	V single braid	0.145		75.0	17.0		
RG-280/U	0.1144 inch copper	F-1	0.327	Silver covered copper double braid	IX	0.480 (max)	0.20	50.0	27.5 (max)	3,000	For low loss applications
RG-281/U	19/0.0378 inch silver covered copper	F-1	0.500	Silver covered copper double braid	VI	0.750 (max)	0.40	50.0	29.0 (max)	4,700	For low loss applications
RG-282/U	0.0253 inch silver covered copper	A*	0.099	Silver covered copper double braid	IX	0.200	0.50 oz/ft	54.8		4,500	*Irradiated polyethylene core for 150° C operation
RG-283/U	19/0.117 inch silver covered copper	D	0.288	Silver covered copper double braid	IV	0.475 (max)	2.31 oz/ft	46.0		6,000	For 150° C operation
RG-293/U	0.106 inch copper	A		Silver covered copper single braid	Neoprene	0.545		50.0			Not compatible with chaining connection
RG-294/U	2-conductor 1-copper 1-tinned copper	A		Tinned copper single braid	Neoprene	0.630		95.0			Triaxial

MIL-HDBK-216
SECTION 2A
10 March 1972

SOLID DIELECTRIC R. F. CABLES, FLEXIBLE (Continued)

Type	Inner conductor	Dielectric material 1/	Nominal diameter of dielectric inch	Number and type of shielding braid	Protective covering 2/	Nominal Overall diameter: inch	Weight: Lb/ft	Normal impedance: Ohms	Nominal capacitance: pF/ft	Maximum operating voltage: Volts (max)	Engineering data
RG-295/U	0.195 inch copper	A		Copper single braid	Neoprene	0.895					
RG-296/U	37/0.0334 silver covered copper	Silicone rubber	0.906	Silver covered copper single braid	Neoprene	1.190		50.0	36.4	10,000	
RG-298/U	7/0.201 inch Copper-clad	A			Foamed Polyethylene	0.650					Unshielded Boonist Cable
RG-301/U	7/0.0203 inch Karma Wire	F-1	0.185	Karma Wire single braid	DX	0.245		50.0	29.0	3,000	Replace RG-126/U
RG-302/U	0.025 inch Silver covered copper covered steel	F-1	0.146	Silver covered copper single braid	DX	0.206		75.0	21.0	2,300	Replace RG-140/U
RG-303/U	0.039 inch Silver covered copper covered steel	F-1	0.116	Silver covered copper single braid	DX	0.170		50.0	26.5	1,900	Replace RG-141/U
RG-304/U	0.059 inch Silver covered copper covered steel	F-1	0.145	Silver covered copper double braid	DX	0.280		50.0	28.5	3,000	Replace RG-143A/U
RG-307A/U	0.058 19/0.00 inch Silver covered copper	Foamed polyethylene	0.146	Silver covered copper single braid	III A	0.270		75.0		400	Interlayer is weather resistant
RG-316/U	7/0.0067 inch Silver covered annealed copper covered steel	F-1	0.060	Silver covered copper single braid	IX	0.102		50.0		1,200	High temperature similar to RG-188A/U
RG-325/U	19 Strand silver plated copper wire	F-2	0.254	Silver plated copper braid	III A	0.445 (max)		50.0			

MTL-HDBK-216
SECTION 2A
10 March 1972

SOLID DIELECTRIC R. F. CABLES, FLEXIBLE (Continued)

Type	Inner conductor	Dielectric material 1/	Nominal diameter of dielectric	Number and type of shielding braid	Protective covering 2/	Nominal Overall diameter	Weight	Nominal impedance	Nominal capacitance	Maximum operating voltage	Engineering data
RG-326/U	19 Stranded silver plated copper wire	F-2	.550 Inch	Silver plated copper braid	B1A	.579 Inch (max)	Lb/ft	50.0	μfd/ft	Volts (rms)	
RG-327/U	19 Stranded silver plated copper wire	F-2	.690 Inch	Silver plated copper braid	B1A	1.18 Inch (max)		50.0			

1/Dielectric material

- A- Polyethylene
- B- Polyisobutylene
- C- Synthetic-rubber compound
- D- Layer of non-conducting synthetic rubber between thin layers of conducting rubber.
- E- Layer of nonconducting rubber plus two layers of non-conducting synthetic rubber.
- E-1 Solid Polytetrafluoroethylene
- F-2 Taped Polytetrafluoroethylene

2/Dielectric consists of solid polyethylene with non-conducting layers. Nominal diameter of dielectric is value over outer non-conducting layer

- H- Conducting synthetic resin
- J- Insulating latex-rubber compound
- A-1R Polystyrene pigmented red
- K- Synthetic resin compound
- L- Silicone-rubber-treated glass tape

3/Protective covering

- I- Low-temperature polyvinyl chloride, or vinyl-acetate copolymer, colored black.
- II- Non-oxetanone, low-temperature, polyvinyl chloride, or vinyl-acetate copolymer, colored gray.
- III- Same as Type II except colored black.
- III- Polyethylene, natural color.
- IIIa- Polyethylene, colored black.
- IV- Polymers of chloroethylene, colored black.
- V- Fiberglass impregnated with silicone-base varnish.
- VI- Silicone rubber-polymer film.
- VII- Polytetrafluoroethylene.
- VIII- Polychloroethylene.
- IX- Fluorinated ethylene propylene.

MIL-HDBK-216
SECTION 2A
10 March 1972

FLEXIBLE RF COAX. CABLES

Type	Inner conductor	Dielectric material	Diameter over dielectric	Number and type shielding	Outer jacket	Overall diameter	Weight	Impedance ohms	Capacitance	Operating voltage rms	Temperature range °C	Engineering data
RG-317/U	71.029	IX		Copper single braid	Neoprene	0.440		95	13.5	3,000	-55 +80	Tinned Treated 0.215 ca. conductor
RG-328/U	Copper braid over cord	HH	1.065	Copper covers steel Double	VII	1.460	1.469	25	8.5	15,000	-55 +80	Traxial Pulse Low noise
RG-329/L	197.0117 0.059	HH	0.380	Copper covers steel Double	VIII	0.700	0.353	50	50	10,000	-55 +80	Traxial Pulse Low noise
RG-330/C	197.010	AJ		Silver covered copper single braid	MIL-P-22748	0.242		50	28	1,000	-55 +80	13.7 dB/100 ft at 1 GHz
RG-362/U	71.0296 0.089	Low loss Polyolefin		Single copper braid .340	Urethane	0.385		50	30	5,000		
RG-363/U	71.0296 0.089	Low loss Polyolefin		Single copper braid .340	Olefin	0.405		50	31	5,000		
RG-364/U	71.0296 0.089	Low loss Polyolefin		Double copper braid	Urethane	0.415		50	31	5,000		
RG-365/L	71.0296 0.089	Polyolefin	0.360	Double copper braid	III	0.425		50	31	5,000		
RG-389/U	Copper Clad Aluminum .251	Polyethylene Splice	0.635	Double tinned copper	B1a	0.875	0.366	50	22.8	2,000	-55 +80	Low-loss
RG-391/L	710.159 0.040	HAH	0.295	Tin covered copper single braid	IIa	0.405		72		5,000		
RG-392/L	710.159 0.040	HAH	0.295	Tin covered copper single braid	IIa with armor	0.475		72		5,000		RG-391/U with armor
RG-393/L	710.312 inch over silver covered copper	F-1	0.285	Silver covered copper double braid	IX	0.390		50		5,000		

MIL-HDBK-216
SECTION 2A
10 March 1972

AIR ARTICULATED CABLES, (SEMI-RIGID)

Type	Inner conductor type and diameter	Dielectric material	Nominal diameter of dielectric	Outer conductor	Nominal diameter of outer conductor	Protective covering	Nominal Over-all diameter	Nominal impedance	Nominal capacitance	Maximum operating voltage	Engineering data
RG-183/U	0.251 inch copper	Polystyrene tape helical	inch	Tubular aluminum	0.750		inch	Ohms	23	1,800	
RG-197/U	0.300 copper	Polystyrene tape helical		Tubular aluminum	0.875			50	22.5	2,000	
RG-198/U	0.114 copper	Polystyrene filament braid		Tubular aluminum	0.758	Helutec (Polyethylene)	0.600	70			CANCELLED Use RG-178/U
RG-199/U	0.209 copper	Polystyrene tape foil braid		Tubular aluminum	0.875	Helutec (polyethylene)	1.015	70	16		
RG-200/U	0.405 copper	Polystyrene tape foil braid		Tubular aluminum	1.425	Helutec (polyethylene)	1.765	70	16		
RG-231/U	Outside .162 inch solid copper	A cellular or foam	0.450	Tubular stainless aluminum	0.500		0.500	50	25	2,000	MIL-C-2380a Dielect. at GH 3.5 KV RMS
RG-232/U	0.300 inch copper	Polystyrene tape helical	0.710	Tubular stainless aluminum	Inside 0.754 Outside 0.875	Type IIIa	0.980	50	22.5	1,700	
RG-233/U	0.591 inch solid copper	Polystyrene tape helical	1.420	Tubular stainless aluminum	Inside 1.472 Outside 1.625	Type IIIa	1.730	50	22	3,300	
RG-234/U	1.157 inch copper	Polystyrene tape helical	2.775	Tubular stainless aluminum	Inside 2.850 Outside 3.125	Type IIIa	3.375	50	22	6,500	
RG-236/U	0.161 inch copper	Polystyrene tape helical	0.379	Tubular stainless aluminum	Inside 0.421 Outside 0.500			50	24	1,000	
RG-237/U	0.160 inch copper	Polystyrene tape helical	0.379	Tubular stainless aluminum	Inside 0.421 Outside 0.500	Type IIIa	0.575	50	24	1,000	
RG-238/U						CANCELLED	SEE CABLE RG-197/U				
RG-239/U						CANCELLED	SEE CABLE RG-232/U				
RG-240/U	0.591 inch solid copper	Polystyrene tape helical	1.420	Tubular stainless aluminum	Inside 1.472 Outside 1.625			50	22	3,300	
RG-241/U						CANCELLED	SEE RG-233/U				
RG-242/U	1.157 inch solid copper	Polystyrene tape helical	2.775	Tubular stainless aluminum	Inside 2.850 Outside 3.125			50	22	6,500	
RG-243/U						CANCELLED	SEE RG-234/U				
RG-244/U	0.102 inch copper	Polystyrene tape helical	0.379	Tubular stainless aluminum	Inside 0.421 Outside 0.500			75	14.7	900	
RG-245/U	0.102 inch copper	Polystyrene tape helical	0.379	Tubular stainless aluminum	Inside 0.421 Outside 0.500	Type IIIa	0.575	75	15.5	900	

Supersedes page 2-27
of 13 May 1965

MIL-HDBK-216
SECTION 2A
10 March 1972

AIR ARTICULATED CABLES (SEMI-RIGID) (Continued)

Type	Inner conductor type and diameter	Dielectric material	Nominal diameter of dielectric	Outer conductor	Nominal diameter of outer conductor	Protective covering	Nominal Overall diameter	Nominal impedance	Nominal capacitance	Maximum operating voltage	Engineering data
RG-246/U	0.188 inch copper	Polystyrene tape helical	inch 0.710	Tubular seamless aluminum	Inside 0.758 Outside 0.875		inch	Ohms 75	14.7	1,000	
RG-247/L	0.188 inch copper	Polystyrene tape helical	0.710	Tubular seamless aluminum	Inside 0.750 Outside 0.875	Type IIIa	0.980	75	15.2	1,000	
RG-248/U	0.374 inch copper	Polystyrene tape helical	1.420	Tubular seamless aluminum	Inside 1.472 Outside 1.625			75	14.7	3,000	
RG-249/U	0.374 inch copper	Polystyrene tape helical	1.420	Tubular seamless aluminum	Inside 1.472 Outside 1.625	Type IIIa	1.735	75	14.7	3,000	
RG-250/U	0.732 inch copper wire or tube	Polystyrene tape helical	2.775	Tubular seamless aluminum	Inside 2.850 Outside 3.125			75	14.7	6,000	
RG-251/U	0.732 inch copper wire or tube	Polystyrene tape helical	2.775	Tubular seamless aluminum	Inside 2.850 Outside 3.125	Type IIIa	3.275	75	14.7	6,000	
RG-252/U	0.185 inch copper	Polyethylene (see tables) spacer		Tubular seamless aluminum	Inside 0.456 Outside 0.530			50	24.0	1,000	
RG-253/L	0.167 inch copper	Polyethylene (see tables) spacer		Tubular seamless aluminum	Inside 0.456 Outside 0.530	Polyethylene	0.75 (max)	50	24.0	1,000	Core: Max. 50 or equal. Sheath: Alathon or equal
RG-254/L	0.311 inch copper	Polyethylene (see tables) spacer		Tubular seamless aluminum	Inside 0.833 Outside 0.953	Polyethylene	1.130 (max)	50	24.0	1,850	
RG-255/L	0.311 inch copper	Polyethylene (see tables) spacer		Tubular seamless aluminum	Inside 0.833 Outside 0.953			50	24.0	1,850	
RG-256/L	0.311 inch silver covered copper	Polytetrafluoroethylene		Tubular seamless aluminum	Inside 0.833 Outside 0.953			50	24.0	1,850	
RG-257/L	0.606 inch copper tube	Polyethylene (see tables) spacer		Tubular seamless aluminum	Inside 1.622 Outside 1.784			50	24.0	3,640	
RG-258/L	0.606 inch copper tube	Polyethylene (see tables) spacer		Tubular seamless aluminum	Inside 1.622 Outside 1.784	Polyethylene	1.970 (max)	50	24.0	3,640	

Supersedes page 2-27
of 18 May 1965

2.27A1

MIL-HDBK-216
SECTION 2A
10 March 1972

AIR ARTICULATED CABLES, (SEMI-RIGID) (Continued)

Type	Inner conductor type and diameter	Dielectric material	Nominal diameter of dielectric	Outer conductor	Nominal diameter of inner conductor	Protective covering	Nominal Overall diameter	Nominal impedance	Nominal capacitance	Maximum operating voltage	Emergency data
RG-259/U	0.116 inch copper	Polychloroethylene (6 mils) spiral	inch	Tubular aluminum sheathless	Inside 0.318 Outside 0.390		inch	50	24.0	607	
RG-261/U					CANCELLED						
RG-262/U					CANCELLED						
RG-263/U	0.172 inch copper	Polytetrafluoroethylene sheathless		Tubular aluminum sheathless	Outside 0.500			50	21.5	3,000	
RG-264/U	0.160 inch copper	spiral		Corrugated copper tubing	0.490			50	21.5	2,900	
RG-265A/U	Inside .287 inch outside 0.358 inch half hard copper tube	spiral		Corrugated copper tubing	0.795 minor ID - 1.005 OD			50	22.2	1,480	
RG-270/U	0.713 inch copper tube corrugated	spiral		Corrugated copper tubing	1.340 minor ID 1.830 OD			50	22.3	2,720	
RG-284A/U	0.220 inch copper	Polytetrafluoroethylene spiral		Corrugated copper tube	0.795 inch ID 1.005 inch O.D.		1.005	75.0	15.0	1,480	
RG-285A/U	0.1144 inch copper	Polytetrafluoroethylene		Corrugated copper tube	0.795 inch ID 1.005 inch O.D.		1.005	100.0	13.0	1,480	
RG-286/U	0.360 inch I.D. 0.430 inch O.D. copper tube	Polyethylene spiral		Corrugated copper tubing	1.570 inch I.D. 1.830 inch O.D.			75	15.1		
RG-287/U	0.197 inch copper wire	Polyethylene spiral		Corrugated copper tubing	1.570 inch I.D. 1.830 inch O.D.			100	15.5		
RG-292/U	0.430 inch copper tube	Polyethylene spiral		Corrugated copper tube	1.830 inch O.D. 1.570 inch I.D.	Polyethylene flooding compound	1.625	75.0	15.1	2,720	
RG-297/U	0.287 inch I.D. 0.355 inch O.D. copper tube	Polytetrafluoroethylene spiral		Corrugated copper tube	0.795 inch I.D. 1.005 inch O.D.			50.0	21.4		
RG-305/U	0.43 inch O.D. 0.36 inch I.D. copper tube	Fluorinated ethylene propylene		Copper tube	1.570 inch I.D. 1.830 inch O.D.	Polyethylene	1.990	75.0	14.4	2,720	Similar to RG-298/U
RG-306/U	0.173 inch copper	Polyethylene		Tubular aluminum sheathless	0.801 I.D.; 0.875 O.D.	Polyethylene	1.052	75.0	16.5		MIL-C-23816

MIL-HDBK-216
SECTION 24
30 March 1977

AIR ARTICULATED CABLES, (SEMI-RIGID) (Continued)

Type	Inner conductor type and diameter	Dielectric material	Nominal diameter of dielectric	Outer conductor	Nominal diameter of outer conductor	Protective covering	Nominal Overall diameter	Nominal impedance	Nominal capacitance	Maximum operating voltage	Engineering data
RG-318/U	0.358 inch copper tube	Polyethylene spiral	inch	Corrugated copper tube	0.795 I.D. 1.005 O.D.	Polyethylene	1.125	50.0	22.2	1,480	
RG-319A/L	0.713 copper tube	Polyethylene spiral		Corrugated copper tube	1.540 I.D. 1.830 O.D.	Polyethylene	2.000	50.0	22.1	2,720	
RG-321	Corrugated copper 1.140 O.D.	Polyethylene spiral		Corrugated copper tube	2.85 major 2.50 minor	None	2.85	50.0	21.7	3,900 max. rms	
RG-322	Corrugated copper 1.140 O.D.	Polyethylene spiral		Corrugated copper tube	2.85 major 2.50 minor	Polyethylene jacket, bonding compound	3.020	50.0	21.7	3,900 max. rms	Uses high molecular weight polyethylene
RG-323	Copper tube 0.312 O.D.	Polyethylene foam		Corrugated copper tube	0.980 major	Polyethylene jacket, bonding compound		50	25.6	1,480 rms	
RG-324	Copper tube 0.312 O.D.	Polyethylene foam		Corrugated copper tube	0.980 major			50	25.6	1,480 rms	

MIL-HDBK-216
SECTION 2A
10 March 1972

SEMI-FLEXIBLE RF COAX CABLES

Type	Inner conductor	Dielectric material	Diameter over dielectric	Number and type strands	Outer jacket	Overall diameter	Weight	Impedance ohms	Capacitance	Operating Voltage rms	Temperature range °C	Exposure data
RG-331/U	Solid copper 0.162	AF		Aluminum tube .450 I.D. .500 O.D.	Syn resin	0.625 (max.)		50	25	2,000	-55 +80	RG-231 with jacket
RG-332/U	Solid copper 0.288	AF	0.801	Aluminum tube .801 I.D. 0.875 O.D.	None	.875		50	25	3,800	-55 +80	
RG-333/U	Solid copper 0.288	AF		Aluminum tube .801 I.D. .875 O.D.	Syn resin	1.052		50	25	3,000	-55 +80	Jacketed RG-332
RG-334/U	Solid copper .098	AF	0.450	Aluminum tube .450 I.D.	None	.500		75	17	2,300	-55 +80	
RG-335/U	Solid copper .098	AF		Aluminum tube .450 I.D. 0.500 O.D.	Syn resin	0.625 (max.)		75	17	2,300	-55 +80	Jacketed RG-334
RG-336/U	Solid copper .177	AF	0.801	Aluminum tube .801 I.D. 0.875 O.D.	None	0.875		75	17	2,500	-55 +80	Like RG-306 without jacket
RG-360/U	Copper wire .343	AF	0.676	Aluminum tube 0.750 O.D.	II	.825		50	25	2,500	-55 +80	
RG-366/U	Solid copper .312	AF		Corrugated copper	III	.620		50	26.6		-55 +80	4,000 Vrms dielect strength
RG-367/U	Corrugated copper tube			Corrugated copper	II	5.14	4.59	50	21.7	6,830	-55 +80	250 W Watts peak
RG-369/U	Copper .117	"A" tubes	.318	Aluminum tube	I	.470	.140	50	24	697	-55 +80	4 pole tube dielect.
RG-370/U	Copper .117	"A" tubes	.318	Aluminum tube	None	.390	.100	50	24	700	-55 +80	RG-369 less jacket
RG-371/U	.27/37 AWG	Irradiated "A"		.001 plated copper	Irradiated "A"	.140		50	32	3,000		
RG-376/U	Copper tube .312	AF		Corrugated aluminum tube	III	1.060	.390	50	26		-55 +80	6,000 VDC dielect strength
RG-377/U	Copper tube .165	Suction tubes		Aluminum tube		.530	.170	50	24	1,000	-55 +200	
RG-378/U	Copper Polyth tube 0.713			Aluminum tube 1.156 1.83	Polyth	2.000		50	22.1			MIL-C-22931
RG-382/U	Copper tube			Aluminum tube		1.578		50			-55 +80	RG-153 except aluminum outer conductor Rapid loss
RG-385/U	Silver plated copper .153	AF		Corrugated aluminum		.495		50	25		-55 +80	2,000 Vrms dielectric strength 42 dB/100 ft. 30 MHz

MIL-HDBK-216
 SECTION 3A
 18 May 1965
 SUPERSEDING
 Section 3
 4 January 1962

SECTION 3A
 R.F. CONNECTORS

3-1 General considerations.

The R. class of connectors are frequently called coaxial connectors because a majority of them are coaxial in design and are used with coaxial cables. They are applied in most cases to circuits carrying R. F. current. They are also used in many systems applications where they serve a shielding function for low-level signal circuits or for audio circuits over shielded single-conductor wire or coaxial cable. The shielding function is important whether it be to protect the center conductor from outside electrical fields or to protect nearby circuits from the influence of the field around the connector center conductor.

True coaxial R.F. connectors are designed with a specific relationship between the outside diameter of the single inner contact, which lies on the axis of the connector, and the inside diameter of the outer sleeve or barrel of the connector shell. The relationship of these diameters, and the dielectric between them, determines the characteristic impedance of the connector. Improved coaxial connectors designed for R.F. use have been proportioned internally so that they will match particular R.F. cable impedance values. With these connectors, R.F. current in a coaxial cable circuit will not "see" any impedance discontinuity as it flows through connectors used either to extend the cable or to terminate it.

Impedance discontinuity in R.F. connectors adversely affects circuits in which timing or, to be specific, phasing relationships, are important. Radar applications are typical. An impedance discontinuity can produce reflections that result in multiple echo readings and ranging errors. The most commonplace example of reflection effects produced by impedance discontinuities in R.F. circuits is the multiple image or ghost pattern on a television receiver. The time difference in arrival of the signal and the signal echo or echoes produced by reflections at points of impedance discontinuity is measured by the spacing of the principal cathode ray indicator tube picture or pip and the echo pictures or pips.

While steps have been taken in all of the more modern R.F. connector series groups to achieve moisture-proofing, none of the connectors can be classed as truly moisture-proof and suitable for outdoor use unless protected by auxiliary materials. The most common practice used to protect the mating interface between plug and receptacle is to pack one side with silicone grease. The connectors are then mated and any excess of grease that is expelled is wiped around the outside of the coupling mechanism. This type of protection can only be classed as useful for a specific time interval. The grease tends to dry and form voids, which can become water traps during periods of temperature change with high humidity. In addition, such packing could adversely affect RF performance of the mated connector pairs. Matched connectors for operation above 1000 Mc utilize high impedance compensating air sections at the mating faces. Packing these mating faces with silicone grease must result in filling these air sections with grease, which has greater dielectric constant. The result is a low impedance section with resultant mismatch and system malfunction. If grease packing cannot be avoided, connector pairs should be opened, cleaned and repacked periodically.

An alternate and preferred method of moisture-proofing where the connectors must be outdoors, is to utilize connectors that mate by threading, such as the Type N or Type HN Series. The mating threads on the receptacle side can be coated with Glyptal varnish just prior to making the connection. After assembly, the entire outer surfaces of the plug and receptacle can be coated with the varnish. UHF-Series connectors may be Glyptal coated outside, but the threads should never be Glyptal varnish coated because R.F. current transfer from plug to receptacle takes place along the outer conductor or shield at the threaded surface. If Glyptal varnish is applied to the threads of coupling devices, it will render them useless for future mating.

A third method for moisture-proofing mated R.F. connectors is to use good quality pressure-sensitive adhesive coated vinyl tape over the connector junction. As in case of silicone grease protection, taping should be renewed periodically. If both the silicone grease and taping are used, any excess of grease on the outside of the connector assembly should be removed completely with a solvent such as carbon tetrachloride before taping the assembly. The method of protection against environmental exposure is described in figure 1.1, under the following conditions:

- a. Permanent or semi-permanent outdoor installations where uncoupling is not anticipated more frequently than approximately once each three months or longer.
- b. Installation where assemblies are to be buried underground.
- c. Applications where sustained water submersion may be encountered without frequent need for uncoupling.

MIL-HDBK-216
SECTION 3A
18 May 1965

Whether or not additional protection or tape is used, proper assembly of the connector to the cable is mandatory for satisfactory electrical operation of the cable and retention of waterproofness.

Figure 1.1 - Instructions for taping coaxial cable junctions

1. Connectors should be properly assembled to the cable. Assembly instructions for the various connector types are shown herein.
2. After two lengths of cable are connected together, tightly apply tape on cable immediately behind the connector to provide a smooth contour between cable and connector.



3. Tightly wrap several layers of tape with a 50 percent overlap over the built-up junction.
 - The layers should be applied in reverse directions and a minimum of four layers should be used.
4. The completely taped covering should extend beyond each connector for a distance equal to 8 - 12 times the diameter of the cable and have a smooth and symmetrical contour. (Approximate dimensions are indicated)



5. The tape should be 1/2" or 3/4" wide, black in color and 0.007 in thickness in accordance with MIL-I-7798.
6. The tape may be moved by unwrapping it. If a knife is used to remove the tape, care should be used not to cut the cable jacket. It is recommended the tape be cut in the immediate vicinity of the connector and then be peeled off.

In many LC and QDL connectors the dielectric of the cable core is used for the connector insulation; and the inner conductor of the cable is used as the center contact pin of the connector.

3-2 Tables.

This part contains information pertaining to R. F. connectors used with R. F. cables, including adapters used between coaxial cables and rigid lines, and between connector series. A guide to the selection of preferred R. F. connectors is included for ready reference. This guide contains functional descriptions, electrical characteristics, and application data. Also included is a cross-reference of cables and associated mating connectors to facilitate the selection of such items.

The connectors listed in this part have been divided into various series according to their functional use and have been arranged generally in accordance with the sizes of the cable with which they are used.

MIL-HDBK-216
SECTION 3A
10 March 1972

GUIDE TO SELECTION OF RF COAXIAL
CONNECTORS FOR AEROSPACE APPLICATIONS

For aerospace applications, only connectors having the more positive threaded coupling and adapted to the more reliable permanent crimp cable assembly technique are recommended for use by original equipment manufacturers.

Preferred connectors for 0.150 to 0.250 O. D. cable range:

Part numbers	Use dash numbers	
M39012/26- /27- /28- /29- /30- /31-, -/32-, and -/34-	Under category B or C ^{1/} All dash numbers	See TNC series starting on page 3.30B

^{1/}See 3.30B1 concerning availability of Military crimping tools.

Preferred connectors for 0.300 to 0.550 inch O. D. cable range:

Part numbers	Use dash numbers	
M39012/35- -/36- -/37- -/38- -/39- -/40- -/41-, -/42-, and -/43-	Under category B or C All dash numbers	See "SC" series starting on page 3.33B

MIL-HDBK-216
SECTION 3A
18 May 1965

GUIDE TO SELECTION OF PREFERRED RF COAXIAL CONNECTORS

CONNECTOR SERIES	TYPE	DESCRIPTION ^{1/}	NOMINAL IMPEDANCE	MAY BE USED WITH CABLE TYPES ^{2/}	APPLICATION INFORMATION
BNC	UG-88E/U	PLUG	50 OHMS	RG-55, -58 -141, -142 -223/U	<ol style="list-style-type: none"> General purpose weather-proof, coaxial connectors for small size R. F. cables. Bayonet lock coupling. Rated at 500 volts peak. Practical frequency limit: 10,000 mcs, with a VSWR of 1.35:1 in a .50 ohm system. Designed to operate up to 200° C.
	UG-89C/U	JACK			
	UG-253B/U	JACK, bulkhead, pressurized			
	UG-909B/U	JACK, bulkhead, 1/2" "D" hole mount			
	UG-913A/U	PLUG, right angle			
	UG-260D/U	PLUG	NON CONSTANT	RG-59, -62, -71, -140/U	
	UG-261C/U	JACK			
	UG-910B/U	JACK, bulkhead, 1/2" "D" hole mount			
	UG-306B/U	ADAPTER, right angle (F-M)	50 OHMS		
	UG-491B/U	ADAPTER, straight, (M-M)			
	UG-492D/U	ADAPTER, bulkhead, pressurized, 1/2" "D" hole mount (F-F)			
	UG-914/U	ADAPTER, straight (F-F)			
	UG-274B/U	ADAPTER, tee (F-M-F)			
	UG-911A/U	RECEPTACLE, pressurized 1/2" "D" hole mount			
	UG-912A/U	RECEPTACLE, pressurized 3/8" "D" hole mount			
	UG-625B/U	RECEPTACLE, 7/16" "D" hole mount			
	UG-1094A/U	RECEPTACLE, bulkhead, 3/8" "D" hole mount			
	UG-1098A/U	RECEPTACLE, bulkhead, right angle, 3/8" "D" hole mount			
	UG-1174/U	RECEPTACLE, bulkhead, right angle, 3/8" "D" hole mount			
	CW-123A/U	CAP AND CHAIN (to cap female connectors)			
CW-282/U	CAP AND CHAIN (to cap male connectors)				
MX-195A/U	HOOD	RG-55, -58, -59, -62, -71, -141, -142, -223/U			

MIL-HDBK-216
SECTION 3A
18 May 1965

GUIDE TO SELECTION OF PREFERRED RF COAXIAL CONNECTORS (Continued)

CONNECTOR SERIES	TYPE	DESCRIPTION ^{1/}	NOMINAL IMPEDANCE	MAY BE USED WITH CABLE TYPES ^{2/}	APPLICATION INFORMATION
C	UG-626B/U	PLUG	50 OHMS	RG-6, 21, 143, 212, 213/U	<ol style="list-style-type: none"> 1. General purpose, weather-proof, coaxial connectors. 2. Bayonet lock coupling. 3. Rated at 1500 volts peak. 4. Practical frequency limit 10,000 mcs, with a VSWR of less than 1.35:1 in a 50 ohm system. 5. Designed to operate up to 200° C.
	UG-630A/U	JACK, bulkhead, 3/4" D hole mount			
	UG-633A/U	JACK			
	UG-570A/U	JACK, panel, 3/4" D hole mount			
	UG-572A/U	JACK			
	UG-573B/U	PLUG			
	UG-710B/U	PLUG, right angle			
	UG-937A/U	JACK, bulkhead, 3/4" D hole mount			
	UG-943B/U	PLUG			
	UG-944A/U	JACK			
	UG-945B/U	PLUG, right angle			
	UG-707B/U	PLUG	50 OHMS	RG-8, 9, 11, 13, 41, 63, 144, 213, 214, 216/U	
	UG-708B/U	PLUG			
	UG-711B/U	PLUG (for high temperature operation up to 250° C)			
	UG-567A/U	ADAPTER, right angle (M-F)			
	UG-642A/U	ADAPTER, straight (M-M)			
	UG-643/U	ADAPTER, straight (F-F)			
	UG-1135/U	ADAPTER (F-F), bulkhead			
	UG-701/U	ADAPTER, bulkhead, pressurized, 3/4" D hole mount (F-F)			
	UG-566A/U	ADAPTER, tee (F-M-F)			
	UG-569A/U	RECEPTACLE, 3/4" D hole mount			
	UG-705A/U	RECEPTACLE, 3/4" D hole mount pressurized	50 OHMS	RG-10, 12, 79, 125, 215/U	
	MX-1142/U	CAP AND CHAIN (to cap female connectors)			
MX-1143/U	CAP AND CHAIN (to cap male connectors)				
MX-1144/U	HOOD				
MX-1286/U	ARMOR CLAMP				
MX-1870/U	HOOD				
					RG-217/U
					RG-17, 35, 218/U
					RG-211, 228/U
					RG-8, 9, 11, 12, 41, 63, 79, 144, 213, 214, 215, 216/U
			RG-12, 215/U		
			RG-55, 58/U		

MIL-HDBK-216
SECTION 3A
18 May 1965

GUIDE TO SELECTION OF PREFERRED RF COAXIAL CONNECTORS (Continued)

CONNECTOR SERIES	TYPE	DESCRIPTION ^{1/}	NOMINAL IMPEDANCE	MAY BE USED WITH CABLE TYPES ^{2/}	APPLICATION INFORMATION
PULSE	UG-34/U	PLUG, (voltage rating 6,000 volts, peak)		RG-25, 26, 64, 77, 78, 88/U	<ol style="list-style-type: none"> 1. High voltage weather-proof, coaxial connectors for use with pulse cables. 2. Ceramic insert type.
	UG-36/U	PLUG, (voltage rating 13,000 volts, peak)		RG-27/U	
	UG-174/U	PLUG, (voltage rating 13,000 volts, peak)		RG-28/U	
	UG-222B/U	ADAPTER, panel mount 3" square mounting flange, 4 holes (voltage rating 13,000 volts, peak) (F-F)			
	UG-37A/U	RECEPTACLE, pressurized 2-3/4" dia., mounting flange, 6 holes (voltage rating, 13,000 volts, peak)			
	UG-38A/U	RECEPTACLE, pressurized air to oil, 2-3/4" dia., mounting flange 6 holes, (voltage rating 13,000 volts, peak)			
	UG-62A/U	RECEPTACLE, pressurized 1-13/16" dia., mounting flange 6 holes (voltage rating 13,000 volts, peak)			
	UG-350/U	RECEPTACLE, bulkhead 1/2" single hole mount, (voltage rating 6,000 volts peak)			

MIL-HDBK-216
SECTION 3A
18 May 1965

GUIDE TO SELECTION OF PREFERRED RF COAXIAL CONNECTORS (Continued)

CONNECTOR SERIES	TYPE	DESCRIPTION ^{1/}	NOMINAL IMPEDANCE	MAY BE USED WITH CABLE TYPES ^{2/}	APPLICATION INFORMATION
PULSE	UG-180A/U	PLUG (voltage rating 6,000 volts, peak)		RG-25,26,64,77,78, 88/U	<ol style="list-style-type: none"> High voltage weather-proof coaxial connectors for use with pulse cables. Rubber insert type. Satisfactory up to 5,000 volts peak at 50,000 ft. altitude.
	UG-181A/U	JACK, bulkhead, 1" single hole mount (voltage rating 6,000 volts, peak)			
	UG-1085/U	PLUG, right angle (voltage rating 6,000 volts, peak)			
	UG-1086/U	JACK, right angle (voltage rating 6,000 volts, peak)			
	UG-264/U	RECEPTACLE, 1-15/32" square mounting flange, 4 holes (voltage rating 6,000 volts, peak)			
	UG-336A/U	ADAPTER, bulkhead pressurized, 1-1/8" D hole mount (voltage rating 6,000 volts peak) (M-F)			
QDS	UG-967B/U	JACK	50 OHMS	RG-8,213,215/U RG-12,215/U RG-74,217/U RG-8,213,215/U	<ol style="list-style-type: none"> Weather-proof coaxial connectors. Small type, quick disconnect coupling. Designed to operate up to 200°C.
	UG-968B/U	PLUG			
	UG-1132A/U	JACK			
	UG-1134/U	PLUG			
	UG-1135/U	JACK			
	UG-976/U	ADAPTER straight (F-F)			
	UG-972B/U	RECEPTACLE			
	UG-1010/U	RECEPTACLE			
	UG-1180/U	RECEPTACLE			
			50 OHMS		

MIL-HDBK-216
SECTION 3A
18 May 1965

GUIDE TO SELECTION OF PREFERRED RF COAXIAL CONNECTORS (Continued)

CONNECTOR SERIES	TYPE	DESCRIPTION ^{1/}	NOMINAL IMPEDANCE	MAY BE USED WITH CABLE TYPES ^{2/}	APPLICATION INFORMATION
QDL	UG-946/U	PLUG	50 OHMS	RG-17, 218/U	<ol style="list-style-type: none"> Weatherproof, coaxial connectors. Large type, quick disconnect coupling.
	UG-1020A/U	PLUG			
	UG-1073A/U	JACK			
	UG-1074A/U	JACK, panel			
	UG-1075C/U	JACK			
	UG-1076C/U	JACK, panel			
	UG-1133/U	PLUG			
	UG-934A/U	ADAPTER, straight (F-F)			
	UG-1061A/U	ADAPTER, right angle (M-F)			
	UG-989A/U	RECEPTACLE	50 OHMS		
QL	UG-1392/U	PLUG	50 OHMS	RG-218/U	<ol style="list-style-type: none"> General purpose weatherproof, coaxial connectors. Large type, quick coupling.
	UG-1393/U	PLUG			
	UG-1397/U	RECEPTACLE			
	UG-1398/U	RECEPTACLE			
QM			50 OHMS		<ol style="list-style-type: none"> General purpose, weatherproof, coaxial connectors. Medium type, quick coupling.
	UG-1394/U	PLUG			
	UG-1399/U	RECEPTACLE			
TPS			50 OHMS		<ol style="list-style-type: none"> General purpose weatherproof coaxial connectors. Bayonet lock coupling. Rated at 400 volts rms. For use with small size coaxial cables. Practical frequency limit: 10,000 mcs.
	UG-1366/U	PLUG			
	UG-1384/U	RECEPTACLE, bulkhead			
	UG-1387/U	ADAPTER (F-F)			
	UG-1412/U	PLUG			
	UG-1416/U	RECEPTACLE			
LT	UG-532A/U	PLUG	50 OHMS	RG-211, 218/U	<ol style="list-style-type: none"> Similar to LC series except not interchangeable
	UG-533B/U	ADAPTER (FF)			
	UG-534B/U	ADAPTER, right angle (M-F)			

MIL-HDBK-216
SECTION 3A
18 May 1965

GUIDE TO SELECTION OF PREFERRED RF COAXIAL CONNECTORS (Continued)

CONNECTOR SERIES	TYPE	DESCRIPTION ^{1/}	NOMINAL IMPEDANCE	MAY BE USED WITH CABLE TYPES ^{2/}	APPLICATION INFORMATION
TWIN	UG-421B/U	PLUG	95 OHMS	RG-22/U	<ol style="list-style-type: none"> General purpose, weatherproof, twin connectors for balanced medium size cables. Rated at 500 volts peak. Practical frequency limit: 200 mcs, maximum frequency limit: 500 mcs. Mounting data for panel mounted connectors: 4 holes, 1/8" Dia., .718" between centers. Overall flange dimensions are 1" square by .075" thick.
	UG-423B/U	JACK, panel			
	UG-422/U	RECEPTACLE	NON		
	UG-493A/U	ADAPTER, straight (F-F)	CONSTANT		
	UG-981/U	ADAPTER, right angle (M-F)			
	UG-106/U	HOOD		RG-22/U	
LC	UG-154A/U	PLUG	50 OHMS	RG-17, 18, 219/U	<ol style="list-style-type: none"> Weatherproof coaxial connectors. Large connectors employing a screw type coupling.
	UG-156A/U	PLUG		RG-19, 20, 220 221/U	
	UG-155B/U	ADAPTER (F-F)			
	UG-157B/U	ADAPTER (F-F)	50 OHMS		
	UG-208B/U	ADAPTER, right angle (F-M)			
	UG-216B/U	ADAPTER, right angle (F-M)			
	UG-219B/U	ADAPTER, right angle (F-M)			
	UG-287B/U	ADAPTER (F-F)			
	UG-352B/U	RECEPTACLE			

MIL-HDBK-216
SECTION 3A
18 May 1965

GUIDE TO SELECTION OF PREFERRED RF COAXIAL CONNECTORS (Continued)

CONNECTOR SERIES	TYPE	DESCRIPTION ^{1/}	NOMINAL IMPEDANCE	MAY BE USED WITH CABLE TYPES ^{2/}	APPLICATION INFORMATION
N ^{3/}	UG-18E/U	PLUG	50 OHMS	RG-6, 143, 212, 222/U	<ol style="list-style-type: none"> General purpose weatherproof coaxial connectors for medium size RF cables. Screw lock coupling. Rated at 1,500 volts peak. Practical frequency limit: 10,000 mcs with a VSWR of less than 1.35:1 in a 50 ohm system. Mounting data for receptacles: 4 holes, 1/8" dia. 0.718" between centers. Overall flange dimensions are 1" square by 0.080" thick. Designed to operate up to 200°C.
	UG-20E/U	JACK			
	UG-159C/U	JACK, bulkhead 5/8" single hole mount			
	UG-21F/U	PLUG		RG-8, 9, 11,	
	UG-23F/U	JACK		13, 41, 63,	
	UG-160E/U	JACK, bulkhead 5/8" single hole mount		114, 144, 213, 214,	
	UG-594A/U	PLUG, right angle		216/U	
	UG-1185A/U	JACK		RG-8, 9,	
	UG-1186A/U	PLUG		213, 214/U	
	UG-935C/U	JACK, bulkhead		RG-12, 215/U	
	UG-936B/U	JACK, bulkhead 5/8" single hole mount			
	UG-940C/U	JACK		RG-81/U	
	UG-941C/U	PLUG			
	UG-483/U	JACK		RG-82/U	
	UG-486/U	PLUG			
	UG-484/U	JACK		RG-55, 58 223/U	
	UG-487/U	PLUG			
	UG-536B/U	PLUG			
	UG-556B/U	JACK, bulkhead, 5/8" single hole mount		RG-217/U	
	UG-1095B/U	JACK, panel			
UG-204D/U	PLUG	RG-224/U			
UG-1006B/U	PLUG	RG-17, 218/U			
UG-167E/U	PLUG	RG-219, 228/U			
UG-982/U	PLUG				
UG-1003/U	PLUG	50 OHMS	RG-63, 114/U		

MIL-HDBK-216
SECTION 3A
18 May 1965

GUIDE TO SELECTION OF PREFERRED RF COAXIAL CONNECTORS (Continued)

CONNECTOR SERIES	TYPE	DESCRIPTION ^{1/}	NOMINAL IMPEDANCE	MAY BE USED WITH CABLE TYPES ^{2/}	APPLICATION INFORMATION	
N ^{3/}	UG-603A/U	PLUG	50 OHMS	RG-59, 62, 71/U	<ol style="list-style-type: none"> 1. General purpose weatherproof coaxial connectors for medium size RF cables. 2. Screw lock coupling. 3. Rated at 1,500 volts peak. 4. Practical frequency limit: 10,000 mcs with a VSWR of less than 1.35:1 in a 50 ohm system. 	
	UG-27C/U	ADAPTER, right angle (M-F)				
	UG-29B/U	ADAPTER, straight (F-F)				
	UG-30E/U	ADAPTER, bulkhead pressurized, 5/8" single hole mount (F-F)				
	UG-57B/U	ADAPTER, straight (M-M)				
	UG-1018/U	ADAPTER, straight pressurized (M-M)				
	UG-680A/U	RECEPTACLE, pressurized.				
	UG-997A/U	RECEPTACLE, rt. angl.				
	UG-28A/U	ADAPTER, tee (F-F-F)				
	UG-107B/U	ADAPTER, tee (F-M-F)				
	UG-106/U	HOOD	50 OHMS	RG-8,9,11,12, 13,22,63,71, 210,213,214, 215,216/U	<ol style="list-style-type: none"> 5. Mounting data for receptacles: 4 holes, 1/8" dia. 0.718" between centers. Overall flange dimensions are 1" square by 0.080" thick. 	
	MX-913/U	CAP AND CHAIN (to cap female connectors)				
	MX-1441/U	ARMOR CLAMP				RG-219, 228/U
	MX-1462/U	ARMOR CLAMP				RG-224/U
	MX-1286/U	ARMOR CLAMP		RG-12, 215/U	<ol style="list-style-type: none"> 6. Designed to operate up to 200° C. 	

MIL-HDBK-216
SECTION 3A
18 May 1965

ADAPTERS (Between Series, Straight)

TYPE	DESCRIPTION	NOMINAL IMPEDANCE	WEATHERPROOF	APPLICATION INFORMATION ^{1/}		
UG-201A/U	N to BNC	50 OHMS	YES	Couples N (F) to BNC (M)		
UG-349B/U	N to BNC			Couples N (M) to BNC (F)		
UG-564/U	C to N			Couples C (M) to N (F)		
UG-565A/U	C to N			Couples C (F) to N (M)		
UG-635/U	C to BNC			Couples C (M) to BNC (F)		
UG-636A/U	C to BNC			Couples C (F) to BNC (F)		
UG-637/U	C to UHF	50 OHMS	YES	Couples C (M) to UHF (F)		
UG-702/U	C to HN	50 OHMS	YES	Couples C (M) to HN (M)		
UG-703A/U	C to HN			Couples C (F) to HN (M)		
UG-966/U	QDS to N			Couples QDS (M) to N (F)		
UG-977C/U	QDL to QDS			Couples QDL (M) to QDS (M)		
UG-1013A/U	QDL to N			Couples QDL (M) TO N (M)		
UG-568B/U	LT to LC			Couples LT (M) to LC (M)		
UG-587B/U	LT to LC			Couples LT (M) to LC (M)		
UG-1136/U	BNC to QDS			Couples BNC (F) to QDS (M)		
UG-1146/U	QDS to BNC			50 OHMS	YES	Couples QDS (F) to BNC (M)

^{1/} Sex of contacts is indicated by the letters (F) and (M).

^{2/} Underlined cables are not matched electrically with associated connectors. Listed cables also include improved versions.

^{3/} For the Department of the Army and Navy, the "N" series are to be used for replacement purposes only. For new equipments, series "C" connectors are to be used.

NOTE: Pressurized connectors will withstand a pressure of 30 psi.

MIL-HDBK-216
SECTION 3A
18 May 1965

GUIDE TO SELECTION OF PREFERRED RF COAXIAL CONNECTORS

CONNECTOR SERIES	TYPE	FUNCTIONAL DESCRIPTION	FOR USE WITH CABLE TYPES	ENGINEERING DATA
MINIATURE (SCREW-ON) CONNECTORS	UG-1460/U	PLUG	RG-178, 196/U	Mates with UG-1462/U and UG-1463/U
	UG-1461/U	PLUG, right-angle	RG-178, 196/U	Mates with UG-1462/U and UG-1463/U
	UG-1462/U	PLUG	RG-178, 196/U	Mates with UG-1460/U right-angle plug UG-1461/U.
	UG-1463/U	RECEPTACLE	RG-178, 196/U	Mates with UG-1460/U and right-angle plug UG-1461/U.
	UG-1464/U	RECEPTACLE	MINIATURE RF CABLES	
	UG-1465/U	PLUG	RG-188, 316/U	Mates with UG-1467/U and UG-1468/U.
	UG-1466/U	PLUG, right-angle	RG-188, 316/U	Mates with UG-1467/U and UG-1468/U.
	UG-1467/U	PLUG	RG-188, 316/U	Mates with UG-1465/U and right-angle plug UG-1466/U.
	UG-1468/U	RECEPTACLE	RG-188, 316/U	Mates with UG-1465/U and right-angle plug UG-1466/U
	UG-1619/U	RECEPTACLE	MINIATURE RF CABLES	

MIL-HDBK-216
SECTION 3A
18 May 1965

R. F. CABLES VS APPLICABLE R. F. CONNECTORS

This part contains a cross reference of cables vs applicable connectors and was prepared for informational purposes only to facilitate the selection of connectors for specific cable.

Cable and connector types listed include all versions except for cables RG-211/U thru RG-228/U, where previous versions of the connectors referenced are not physically compatible with the respective cable.

For new design, this cross reference should be used in conjunction with the "Guide to the Selection of Preferred R. F. Coaxial Cable Connectors" contained on pages 3.4 thru 3.12 of this section.

CABLE TYPE RG- /U	CONNECTOR SERIES	APPLICABLE CONNECTORS UG- /U
5	C N	626, 629, 630, & 633 18, 19, 20, 159, 91, 92, 93
6	C N	626, 629, 630, & 633 18, 19, 20, 159, 91, 92, & 93
8	BNC C HN N	959 570, 571, 572, 573, & 710 59, 60, 61, 427, 1213, 1214 21, 22, 23, 160, 594, 1185 & 1186
9	BNC C HN N	959 570, 571, 572, 573, 710 59, 60, 61, 427 21, 22, 23, 160, 594, 1185 & 1186
10	N C HN QDL QDS	935, 936, 940, & 941 937, 938, 939, 942, 943, 944, 945 925, 927, 929, 930 1075, & 1076 967, 968, & 1132
11	BNC C HN N	959 570, 571, 572, 573, 710 59, 60, 61, 427, 1213, 1214 21, 22, 23, 160, 594, 1185, & 1186, 94, 95, & 96
12	C HN N QDL QDS	937, 938, 939, 942, 943, 944, 945 925, 927, 929, & 930 935, 936, 940, & 941 1075, & 1076 967, 968, & 1132
13	BNC C HN N	959 570, 571, 572, 573, 710 59, 60, 61, 427, 1213 & 1214 21, 22, 23, 160, 594 & 1186

MIL-HDBK-216
SECTION 3A
18 May 1965

R. F. CABLES VS APPLICABLE R. F. CONNECTORS (Continued)

CABLE TYPE RG- /U	CONNECTOR SERIES	APPLICABLE CONNECTORS UG- /U
14	C HN LN	707 494 100, 101, 279
17	C HN LC N	708 333, 334, 495 1179, & 1258 167
18	HN LC N QDL	1041, 1102, 1103 154 982, 1195 1020, 1073, 1074
19 & 20	LC	156
21	C N	626, 629, 630, & 633 18, 19, 20, & 159
22	TWIN	102, 103, 106, 421, 422, & 423
23 24	TWIN	
25 26	PULSE	34, 180, 181, 182
27	PULSE	36, 158, & 1141
28	PULSE	166 & 174
34	DHF	357 & 358
35	HN LC N QDL	1041, 1102, 1103 154 982, & 1195 1020, 1073, & 1074
55	BN BNC C N	85, 86, 87, 114, 115, 198, 206, 245, 246, & 342 88, 89, 253, 291, 909, 913 704, & 709 536, 556, 1052, & 1095
57	TWIN	
58	BN BNC C N	85, 86, 87, 114, 115, 198, 206, 245, 246, & 342 88, 89, 253, 291, 909, & 913 704 & 709 536, 556, 1052, & 1095
59	BN BNC C N	85, 86, 87, 114, 115, 198, & 206 260, 261, 291, 624, 909, & 913, 910 704, & 709 602 & 603

R. F. CABLES VS APPLICABLE R. F. CONNECTORS (Continued)

CABLE TYPE RG- /U	CONNECTOR SERIES	APPLICABLE CONNECTORS UG- /U
62	BN BNC C N	85, 86, 87, 114, 115, 198, & 206 260, 261, 262, 624, & 910 627 & 631 593, 602 & 603
63	C HN N	570, 571, 572, 573, 710 59, 60, 61, 427, 1213, & 1214 21, 22, 23, 160, 594, 1185, & 1186
64	PULSE	180, 181, 182, 264, & 1084
65	PULSE	180, 181, 182, 264, & 1084
71	BN BNC C N	85, 86, 87, 114, 115, 198, & 206 260, 261, 262, 624, & 910 627, & 631 593, 602, & 603
74	HN N QDL QDS	1021 1006 1133 1134, & 1135
77 78	PULSE	180, 181, 182, & 264
79	C HN N QDS	937, 938, 939, 942, 943, 944, & 945 925, 927, 929, & 930 935, 936, 940, 1003 967, 968, 1132
81	HN N	312 483, & 486
82	LC N	286, & 314 484, & 487
84		
85	LC	1179
86	TWIN	969
87	BNC C HN N	959 570, 571, 572, 710 59, 60, 61, 427, 1213, & 1214 160, 1185, & 1186/U
88	PULSE	180, 181, 182, 228, 229, & 230
94	HN LN	494 101, 279
100	BNC	527

SUPERSEDES PAGE 3.15 OF 18 MAY 1965

MIL-HDBK-216
SECTION 3A
18 May 1965

R. F. CABLES VS APPLICABLE R. F. CONNECTORS (Continued)

CABLE TYPE RG- /U	CONNECTOR SERIES	APPLICABLE CONNECTORS UG- /U
108 111	TWIN	
114	BNC C HN N	959 570, 571, 572, 573, 710 59, 60, 61, 427, 1213, & 1214 21, 22, 23, 160, 594, 1185 & 1186
115	C HN N	571, 572, 570, 573, & 710 59, 60, 61, 427, 1213, & 1214 21, 22, 23, 160, 483, 594, 1185, & 1186
116	C HN N QDS	937, 938, 939, 942, 943, 944, 945 925, 927, 929, 930 935, 936, 940, & 941 967, 968, & 1132
117	C LT	711 532
118	HN N	926 557
119	LN	530, & 531
120	LN	
122	BNC C N	88, 89, 253, 291, 909, 913, 1033, 1055, 1056, & 1082 704, & 709 536, 556, & 1095
126	C N	626, 629, 630, & 633 18, 19, 20, & 159
130 131	TWIN	1057, & 1060
133	BNC C HN N	959 570, 571, 572, 573, 710 59, 60, 61, 427, 1213, & 1214 21, 22, 23, 94, 95, 96, 160, 594, 1185, & 1186
140	BNC C N	260, 261, 262, 624 627, & 631 602, & 603
141	BNC C N	88, 89, 253, 291, 909, & 913 704, & 709 536, 556, 1052, & 1095
142	BNC C N	88, 89, 253, 291, 909, 913 704 & 709 536, 556, & 1095
143	C N	626, 629, 630, & 633 18, 19, 20, & 159

MIL-HDBK-216
SECTION 3A
18 May 1965

R. F. CABLES VS APPLICABLE R. F. CONNECTORS (Continued)

CABLE TYPE RG- /U	CONNECTOR SERIES	APPLICABLE CONNECTORS UG- /U
144	BNC C HN N	959 570, 571, 572, 573, 710 59, 60, 61, 427 21, 22, 23, 94, 95, 96, 160, 594, 1185 & 1186
149	BNC C HN N	959 570, 571, 572, 573, 710 59, 60, 61, 427, 1213, & 1214 21, 22, 23, 160, 594, 1185 & 1186
150	C HN N QDS	937, 938, 939, 942, 943, 944 & 945 925, 927, 929 & 930 935, 936, 940, & 941 967, 968, & 1132
164	C HN N LC	708 333, 334, 495, 1041 167 1179 & 1258
165	BNC C HN N	959 570, 571, 572, 573, 710 59, 60, 61, 427, 1213 & 1214 21, 22, 23, 160, 594, 1185 & 1186
166	C HN N QDS	937, 938, 939, 942, 943, 944 & 945 925, 927, 929 & 930 935, 936, 940 & 941 967, 968 & 1132
177	C HN N LC	708 333, 334, 495 167 1179, 1258
178	MINIATURIZED	1460, 1461, 1462, 1463
187	MINIATURIZED	1465, 1466, 1467, 1468 (not electrically matched)
188	MINIATURIZED	
195	MINIATURIZED	
196	MINIATURIZED	
209	LT	1305
211	C LT	711B 532
212	N C	18D, 19D, 20D & 159C 626B, 629A, 630A, & 633A
213	BNC C HN N	959A 570A, 571A, 572A, 573B, 710B 59E, 60E, 61E, 427C, 1213 & 1214 21E, 22E, 23E, 160D, 594A, 1185A, 1186A

MIL-HDBK-216
SECTION 3A
18 May 1965

R. F. CABLES VS APPLICABLE R. F. CONNECTORS (Continued)

CABLE TYPE RG- /U	CONNECTOR SERIES	APPLICABLE CONNECTORS UG- /U
214	ENC C HN N	959A 570A, 571A, 572A, 573B, 710B 59E, 60E, 61E, 427C, 1213 & 1214 21E, 22E, 23E, 160D, 594A, 1185A & 1186A
215	C HN N QDS QDL	937A, 938A, 939A, 942B, 943B, 944A & 945B 925B, 927B, 929B, & 930B 935B, 936B, 940B, 941B 967B, 968A & 1132A 1075C & 1076C
216	ENC C HN N	959A 570A, 571A, 572A, 573B, 710B 59E, 60E, 61E, 427C, 1213, & 1214 21E, 22E, 23E, 160D, 594A, 1185A, & 1186A
217	HN LN QM N C	494 101, 279 1394, 1399 204D 707B
218	LC QDL QL HN C N LC	154B 1020B 1392, 1395, 1397 333, 334, 495 708B 167E 1179 & 1258
219	HN N QDL	1041, 1102 & 1103 982 & 1195 1073 & 1074
220	LC QL	156 1393, 1396, 1398
221	LC	156
222	C N	626B, 629A, 630A, & 633A 18D, 19D, 20D & 159C
223	ENC C N	88D, 89C, 253B, 291C, 909A & 913A 704A & 709B 536B, 556A & 1095A
224	HN LN QDS	1021 1079 & 1080 1134 & 1135
225	ENC C HN N	959A 570A, 571A, 572A, 573B, 710B 59E, 60E, 61E, 427C, 1213 & 1214 21E, 22E, 23E, 160D, 594A, 1185A, 1186A
226		None
227	C HN N QDS	937A, 938A, 939A, 942B, 943B, 944A & 945B 925B, 927B, 929B & 930B 935B, 936B, 940B, 941B 967B, 968A & 1132A
228	HN	926
281	LT	1305
316	MINIATURIZED	1465, 1466, 1467, 1468

ADAPTER (Between Series)

The adapters in the following group provide a means of connecting between various solid-dielectric RF Cable Connector Series. They are weatherproof unless otherwise indicated under engineering data.

ADAPTER (Between Series)

Type	Functional Description	Engineering data
UG-83B/U	N to UHF Mates with N male and UHF 49194 or equivalent	Replaces UG-83, -83A/U Not weatherproof.
UG-108A/U	N to LN Mates with N male and LN male	Replaces UG-108/U
UG-146A/U	N to UHF Mates with N female and UHF 49190 or equivalent	Replaces UG-146/U Not weatherproof
UG-201A/U	N to BNC Mates with N female and BNC male	Replaces UG-201/U
UG-213A/U	N to LN Mates with N female and LN female	Replaces UG-213/U
UG-217A/U	LC to HN Mates with HN male LC UG-154/U or equivalent	Replaces UG-217/U
UG-218A/U	LC to HN Mates with LC UG-215/U or equivalent and HN male	Replaces UG-218/U
UG-241/U	UHF to BN Mates with UHF 49195 or equivalent and BN female	Not weatherproof
UG-255/U	BNC to UHF Mates with BNC male and UHF 49190 or equivalent	Not weatherproof
UG-259A/U	HN to LC Mates with HN male and LC UG-154/U or equivalent	Replaces UG-259/U
UG-270A/U	N to LC Mates with N male and LC UG-154/U or equivalent	Replaces UG-270/U
UG-271A/U	N to LC Mates with N male and LC UG-154/U or equivalent	Replaces UG-271/U
UG-273/U	BNC to UHF Mates with BNC male and UHF female.	Not weatherproof

MIL-HDBK-216
SECTION 3A
18 May 1965

ADAPTERS (Between Series) Continued

Type	Functional Description	Engineering data
UG-309/U	BNC to HN Mates with BNC male and HN female	
UG-318/U	UHF to N Mates with N female and UHF 49194 or equivalent	Not weatherproof
UG-327A/U	HN to LC, Mates with one HN male and two LC UG-154/U or equivalent	Adapter, tee; 3 female ends Replaces UG-327/U
UG-335/U	N to BNC Mates with N male and BNC female	Same as UG-349/U except incorporates Square mounting Flange
UG-349B/U	N to BNC Mates with N male and BNC female	Replaces UG-349/U, 349A/U
UG-497A/U	HN to LC Mates with HN male and LC UG-215/U or equivalent	Replaces UG-497/U
UG-516A/U	LN to N Mates with LN female and N male	Replaces UG-516/U
UG-559B/U	BNC to HN Mates with BNC female and HN male	Right angle Replaces UG-559/U
UG-564/U	C to N Mates with C male and N female	
UG-565A/U	C to N Mates with C female and N male	Replaces UG-565/U
UG-586B/U	LT to LC Mates with LT male and LC male	Replaces UG-586, 586A/U
UG-587B/U	LT to LC Mates with LT male and LC male	Replaces UG-587, 587A/U
UG-605/U	BN to N Mates with N male and BN female	
UG-606/U	BNC to N Mates with N male and BNC male	
UG-635/U	C to BNC Mates with C male and BNC female	

MIL-HDBK-216
SECTION 3A
18 May 1965

ADAPTERS (Between Series) Continued

Type	Functional Description	Engineering data
UG-636A/U	C to BNC Mates with C female and BNC male	Replaces UG-636/U
UG-637/U	C to UHF Mates with C male and UHF female	
UG-690/U	BNC to SM Mates with BNC male and SM male	Not weatherproof
UG-691/U	BNC to SM Mates with BNC male and SM female	Pressurized. Not weatherproof
UG-702/U	C to HN Mates with C male and HN female	
UG-703A/U	C to HN Mates with C female and HN male	Replaces UG-703/U
UG-966/U	QDS to N Mates with QDS male and N female	
UG-970/U	Twin to UHF Mates with twin female and UHF male	Right angle one pin grounded to shell
UG-971/U	Twin to C Mates with twin female and C male	
UG-977A/U	QDL to QDS Mates with QDL male and QDS male	Replaces UG-977/U
UG-998/U	LC to LN Mates with LC female and LN male	
UG-999A/U	LC to N Mates with LC female and N male	
UG-1013A/U	QDL to N Mates with QDL male and N male	Center contact modified from closed end to spring finger design. Replaces UG-1013/U
UG-1034/U	BNC to N Mates with BNC female and N female	Not weatherproof

MIL-HDBK-216
SECTION 3A
18 May 1965

ADAPTERS (Between Series) Continued

Type	Functional Description	Engineering data
UG-1107/U	N to HN Mates with N female and HN female	
UG-1108/U	N to HN Mates with N female and HN male	
UG-1136/U	BNC to QDS Mates with BNC female and QDS male	
UG-1137/U	HN to QDS Mates with HN female and QDS male	
UG-1142/U	QDS to C Mates with QDS female and C male	
UG-1143/U	HN to QDS Mates with HN male and QDS female	
UG-1144/U	QDS to N Mates with QDS female and N male	
UG-1146/U	QDS to BNC Mates with QDS female and BNC male	
UG-1166/U	LT to N Mates with LT female and N male	Part of dummy load/AN/URM-58
UG-1167/U	LT to LN Mates with LT female and LN male	Part of dummy load/AM/URM-58
UG-1168/U	LT to LC Mates with LT male and LC male	
UG-1250/U	LT to C Mates with LT male and C male	
UG-1260/U	BNC to R Mates with BNC male and R male	
UG-1287/U	LC to C Mates with LC male and C male	Flange type adapter for Panel type mounting
UG-1288/U	LC to C Mates with LC male and C male	

MIL-HDBK-216
SECTION 3A
18 May 1965

ADAPTERS (Between Series) Continued

Type	Functional Description	Engineering data
UG-1306/U	LT to C Mates with LT male and C male	Flange type adapter for panel type mounting
UG-1368/U	TPS to BNC Mates with TPS male and BNC male	
UG-1374/U	QL to C Mates with QL male and C male	
UG-1375/U	QL to C Mates with QL male and C male	Bulkhead mounted

MIL-HDBK-216
SECTION 3A
18 May 1965

ADAPTERS (Cable to Rigid Line)

The following groups of adapters provide means of connecting solid-dielectric, R. F. cable and rigid, bead-supported, or stud-supported coaxial transmission lines. They are weatherproof unless otherwise indicated under engineering data.

These adapters are divided into the four following groups.

- A. Adapters, cable to rigid line, require plug to connect cable to adapter. Can be field-assembled.
- B. Adapters, high-voltage, cable to rigid line. Cable connects directly to adapter. Can be field-assembled.
- C. Adapters, low-voltage, cable to rigid line. Cable connects directly to adapter. Can be field-assembled.
- D. Adapters, cable to rigid line. Cable molded permanently into adapter. Cannot be field-assembled.

The adapters shown in groups A and B are preferred. Most of those shown in group C have been designed for specific applications and are not recommended for general use. Group D covers, factory-molded adapters. They must be factory-assembled, as dielectric material (normally polyethylene) must be injected into the adapter body and bonded to the cable dielectric. No design of this type is considered pressure-tight. Normally, they are furnished molded to a specified length of cable. When required, additional lengths of cable can be molded to the cable protruding from these adapters.

A - ADAPTERS, PRESSURIZED (Requires Male Plug to Connect Cable to Rigid Line)

Type	Functional Description	Engineering Data
UG-32/U	N to rigid line	Connects to 7/8-inch, 50-ohm line
UG-33/U	N to rigid line	Connects to 7/8-inch, 70-ohm line
UG-233/U	LC to rigid line	Connects to 7/8-inch, 70-ohm line
UG-234/U	LC to rigid line	Connects to 7/8-inch, 50-ohm line
UG-237/U	LC to rigid line	Connects to 7/8-inch, stub line RG-44/U
UG-249/U	HN to rigid line	Connects to 7/8-inch, stub line RG-44/U
UG-250/U	HN to rigid line	Connects to 7/8-inch, 50-ohm line
UG-251/U	HN to rigid line	Connects to 7/8-inch, 70-ohm line
UG-272/U	N to rigid line	Connects to 7/8-inch, stub line RG-44/U
UG-370/U	N to rigid line	Connects to 3/8-inch line
UG-371/U	N to rigid line	Connects to 3/8-inch line
UG-401/U	N to rigid line	Connects to 5/8-inch stub line
UG-402A/U	N to rigid line	Connects to 7/8-inch stub line Replaces UG-402/U
UG-518/U	N to rigid line	Connects to 5/8-inch stub line

MIL-HDBK-216
SECTION 3A
18 May 1965

ADAPTERS, PRESSURIZED, CABLE TO RIGID LINE Continued

Type	Functional Description	Engineering Data
UG-519/U	N to rigid line	Connects to 7/8-inch stub line
UG-582/U	N to rigid line	Connects to 3.028-inch air-filled line
UG-583/U	N to rigid line	Connects to 1-5/8-inch air-filled line
UG-965A/U	LC to rigid line	Connects to 1-5/8-inch line RG-128 Replaces UG-965/U
UG-1047/U	N to rigid line	Connects to 7/8-inch, 50-ohm line Not weatherproof
UG-1048/U	HN to rigid line	Connects to 7/8-inch, 50-ohm line Not weatherproof
UG-1049/U	C to rigid line	Connects to 7/8-inch, 50-ohm line Not weatherproof
UG-1119/U	LC to rigid line	Connects 1-5/8-inch to 50-ohm line Not weatherproof
UG-1120/U	N to rigid line	Connects to 7/8-inch and 50-ohm line
UG-1121/U	N to rigid line	Connects 1-5/8-inch to 50-ohm line
UG-1122/U	N to rigid line	Connects 1-5/8-inch to 50-ohm line
UG-1154/U	N to rigid line	Connects 1-5/8-inch to 50-ohm line
UG-1155/U	N to rigid line	Connects to 7/8-inch to 50-ohm line
UG-1188/U	QDL to rigid line	QDL to dummy load TS-235/up
UG-1251/U	LT to rigid line	Connects 1-5/8-inch to 50-ohm line
UG-1274/U	LT to rigid line	Connects 7/8-inch to 50-ohm line

NOTE: For drawings covering these adapters, see Section 18, Nomenclature Index.

MIL-HDBK-216
SECTION 3A
18 May 1965

B - ADAPTERS, HIGH-VOLTAGE, PRESSURIZED, CABLE TO RIGID LINE

Type	Description	For use with cable types	Weather-proof	Engineering data
UG-161/U	Adapter	RG-19, 20/U	Yes	Connects to 3-1/8-inch, 50-ohm line
UG-168/U	Adapter	RG-17, 18/U	Yes	Connects to 1-5/8-inch rigid line
UG-192/U	Adapter	RG-17, 18/U	Yes	Replaces UG-71/U
UG-207/U	Adapter	RG-14/U	Yes	Connects to RG-44/U stub line
UG-256/U	Adapter	RG-14/U	Yes	Connects to 7/8-inch, 70-ohm line
UG-257/U	Adapter	RG-14/U	Yes	Connects to 7/8-inch, 50-ohm line
UG-258/U	Adapter	RG-17, 18/U	Yes	Connects to 3-1/8-inch, 50-ohm line
UG-313/U	Adapter	RG-81/U	Yes	Connects to 7/8-inch rigid line
UG-315/U	Adapter	RG-82/U	Yes	Connects to 7/8-inch rigid line
UG-316/U	Adapter	RG-82/U	Yes	Connects to 1-5/8-inch rigid line
UG-337/U	Adapter	RG-17, 18/U	Yes	Connects to 3-1/8-inch rigid line
UG-338/U	Adapter	RG-19, 20/U	Yes	Connects to 3-1/8-inch rigid line
UG-1025/U	Adapter			Connects to 1-5/8-inch 50-ohm line
UG-1160/U	Adapter			Connects 7/8 to 1-5/8-inch

C - ADAPTERS, LOW-VOLTAGE, PRESSURIZED, CABLE TO RIGID LINE

Type	Description	For use with cable types	Weather-proof	Engineering data
	Adapter	RG-17, 18/U	Yes	Connects to 7/8-inch 70-ohm line
	Adapter	RG-35/U	Yes	Connects to 7/8-inch 70-ohm line

D - ADAPTERS, HIGH-VOLTAGE, NONPRESSURIZED, CABLE TO RIGID LINE

Type	Description	For use with cable types	Weather-proof	Engineering data
	Adapter	RG-8,9,10/U	Yes	Connects to 7/8-inch 50-ohm line
UG-31/U	Adapter	RG-14/U	Yes	Connects to 1-5/8-inch 50-ohm line

MIL-HDBK-216
SECTION 3A
18 May 1965

BN CONNECTOR SERIES

The connectors described in this part are BN type small, lightweight connectors and are designed for use with small cables such as RG-58/U, RG-59/U, etc.

They have been used for video, I. F. trigger pulse, and low-power, R. F. applications. They are not constant-impedance connectors and are therefore not recommended for applications where frequencies are in excess of approximately 200 megacycles unless the electrical requirements of the circuit are not critical. They may be used at peak voltages up to 250 volts.

BN CONNECTOR SERIES

Type	Functional Description ^{1/}	For use with cable types	Weather-proof	Engineering data
UG-85/U	Plug	RG-55,58,59, 62,71/U	Yes	
UG-86/U	Receptacle, pressurized	RG-55,58,59, 62,71/U	Yes	See note 1
UG-87/U	Receptacle	RG-55,58,59, 62,71/U	Yes	See note 1
UG-114/U	Panel Jack	RG-55,58,59, 62,71/U	Yes	
UG-115/U	Jack	RG-55,58,59, 62,71/U	Yes	
UG-198/U	Receptacle pressurized	RG-55,58,59, 62,71/U	Yes	See note 1
UG-206/U	Receptacle	RG-55,58,59, 62,71/U	No	
UG-242/U	Adapter, tee (F-M-F)			1 male 2 female ends
UG-243/U	Adapter, right- angle (M-F)		Yes	
UG-244/U	Adapter, bulkhead, pressurized (F-F)			2 female ends
UG-245/U	Plug	RG-55,58/U	No	Navy type 49599
UG-246/U	Panel Jack	RG-55,58/U	No	Navy type 49601
UG-342/U	Plug, right-angle	RG-55,58/U	Yes	
UG-377/U	Receptacle		No	
MX-195A/U	Hood	RG-55,58/U	No	
MX-367/U	Hood	RG-59,62,71/U	No	

^{1/}Sex of contacts is indicated by the letters "F" and "M".

NOTES:

1. Requires hood MX-195/U for cables RG-55/U and RG-58/U, and hood MX-367/U for cables RG-59/U, RG-62/U, and RG-71/U.
2. For drawings covering these connectors, see Section 18, Nomenclature Index.

MIL-HDBK-216
SECTION 3A
18 May 1965

BNC CONNECTOR SERIES

The connectors described in this part are small, lightweight, weatherproof connectors employing a bayonet-type coupling, a metal to metal cable clamp, and polytetrafluoroethylene dielectric. They have a nominal impedance of 50 ohms, a maximum peak voltage rating of 500 volts, a practical frequency limit of 10,000 megacycles, and are designed for use with small-size cables.

BNC CONNECTOR SERIES

Type	Functional Description ^{1/}	For use with cable types	Weather-proof	Engineering data
UG-88E/U	Plug	RG-55, 58, & 223/U		Replaces UG-88, 88A, 88B, 88C/U & 88D/U
UG-89C/U	Jack	RG-55, 58 & 223/U		Replaces UG-89, 89A & 89B/U
UG-185/U	Receptacle		Yes	
UG-253B/U	Jack, bulkhead, pressurized	RG-55, 58 & 223/U		Replaces UG-253 & 253A/U
UG-260D/U	Plug	RG-59, 62, & 71/U		Replaces UG-260, 260A, 260B/U & 260C/U
UG-261C/U	Jack	RG-59, 62 & 71/U		Replaces UG-261, 261A & 261B/U
UG-262C/U	Panel Jack	RG-59, 62 & 71/U	Yes	Replaces UG-262, 262A & 262B/U
UG-274B/U	Adapter, tee (F-M-F)		Yes	Replaces UG-274 & 274A/U
UG-282B/U	Adapter, (M) binding-post		No	Replaces UG-282, 282A/U & 924/U
UG-290A/U	Receptacle		Yes	Replaces UG-290, 185, 362, 364 and 365/U
UG-291C/U	Panel Jack	RG-55, 58 & 223/U	Yes	Replaces UG-90, 291, 291A & 291B/U
UG-306B/U	Adapter, (M-F) right-angle		Yes	Replaces UG-306/U & 306A/U
UG-414A/U	Adapter (F-F)		Yes	Replaces UG-414/U
UG-447/U	Receptacle		Yes	
UG-491B/U	Adapter (M-M)		Yes	Replaces UG-491 & 491A/U
UG-492D/U	Adapter, bulkhead, pressurized (F-F)		Yes	Replaces UG-492, 492A/U, 492B/U & 492C/U. 1/2-inch thd mounts in "D" hole.
UG-527/U	Plug	RG-100/U	Yes	
UG-535/U	Receptacle, right-angle		Yes	

MIL-HDBK-216
SECTION 3A
18 May 1965

BNC CONNECTOR SERIES Continued

Type	Functional Description	For use with cable types	Weather-proof	Engineering data
UG-589/U	Plug	Wire W-143	Yes	Single conductor cable
UG-604/U	Receptacle		Yes	
UG-624/U	Jack, bulkhead	RG-59, 71 & 62/U	Yes	
UG-625B/U	Receptacle		Yes	Replaces UG-625; 3/8-inch thd, mounting in "D" hole.
UG-641/U	Adapter (M) binding-post		Yes	Spring loaded binding post, BNC male termination.
UG-657/U	Receptacle, pressurized		Yes	
UG-909B/U	Jack, bulkhead	RG-55, 58 & 223/U	Yes	Replaces UG-909/U & 909A/U. 1/2-inch thd. mounting in "D" hole.
UG-910B/U	Jack, bulkhead	RG-59, 62 & 71/U	Yes	Replaces UG-910/U & 910A/U. 1/2-inch thd. mounting in "D" hole.
UG-911A/U	Receptacle, pressurized		Yes	See note 1. Replaces UG-254A/U & 911/U. 1/2-inch thd mounting in "D" hole; 1/8-inch longer than UG-911/U
UG-912A/U	Receptacle, pressurized		Yes	Replaces UG-912/U. 3/8-inch thd mounting in "D" hole.
UG-913A/U	Plug, right angle	RG-55, 58 & 223/U	Yes	Replaces UG-913/U
UG-914/U	Adapter (F-F)		Yes	
UG-928/U	Receptacle		Yes	
UG-959A/U	Plug	RG-8, 9, 11, 213/U & 214/U	Yes	Replaces UG-959/U
UG-1033/U	Plug	RG-122/U	Yes	
UG-1055/U	Panel Jack	RG-122/U	Yes	
UG-1056/U	Jack	RG-122/U	Yes	
UG-1082/U	Plug	RG-122/U	No	Similar to UG-88C/U except has smaller cable opening.
UG-1090/U	Adapter (F) connector			Adapts female BNC to binding post.
UG-1094A/U	Receptacle		Yes	3/8-inch thd mounting in "D" hole of panel 1/4-inch thick max.
UG-1098A/U	Receptacle right-angle		Yes	Replaces UG-1098/U; 3/8-inch thd mounting in "D" hole.

MIL-HDBK-216
SECTION 3A
18 May 1965

BNC CONNECTOR SERIES Continued

Type	Functional Description ^{1/}	For use with cable types	Weather-proof	Engineering data
UG-1104/U	Receptacle, male			Used for polarization application. Similar to UG-290A/U
UG-1174/U	Receptacle, right-angle		Yes	3/8-inch thd mounting in "D" hole.
UG-1321/U	Adapter			Adapts BNC plug to inner stage CV-322/U
CW-123A/U	Cap and chain		Yes	For use with female connectors. Replaces CW-123/U
CW-155A/U	Cap		Yes	For use with female connectors. Replaces CW-155/U
CW-159/U	Shorting plug		Yes	
CW-282/U	Cap and chain		Yes	For use with male connectors.
MT-412/U	Mounting plate		Yes	For UG-90/U and 185/U
MX-195A/U	Hood	RG-55, 58 & 223/U	No	Replaces MX-195/U.
MX-367/U	Hood	RG-59, 62 & 71/U	No	For use with UG-86/U
MX-554A/U	Resistive cap		Yes	Replaces MX-554/U
MX-1758/U	Hood	RG-59 & 62/U	Yes	
MX-1759/U	Hood	RG-58/U	Yes	

^{1/}Sex of contacts is indicated by the letters "F" and "M".

NOTES:

1. When hood is required with UG-911/U, use MX-195A/U.
2. For drawings covering these connectors, see Section 18.

MIL-HDBK-216
SECTION 3A
10 March 1972

PROPOSED

"BNC" CONNECTOR SERIES

Versions covered under MIL-C-39012

FSC-5935

Accommodates small RF cables in the 0.150 to 0.250 inch O.D. size range

Coupling Type	Bayonet
Material (body)	Brass, 1/2 hard
Material (dielectric)	Polytetrafluoroethylene
Cable Attach:	Category A - Field attach by threaded clamp & solder (reusable)
	Category B - Permanent Crimp (and non-crimp) attach at factory (non-reusable)
	*Category C - Permanent Crimp with Military tool (non-reusable)
Max. Oper Voltage	500 Volts rms
Frequency Range & Impedance	D.C. to 4GHz, 50 ohms
Insertion Loss	0.2 db at 3 GHz
RF Leakage	-55 db at 2 to 3 GHz
Temperature Range	-65 to 165°C
Other Operational Environments	Vibration, moisture, 70,000 ft altitude, and so forth

*Do not procure until Military crimp tool is available to users.

Explanation of symbols used in the following connector lists:

- (m) = male center contact
 (f) = Female center contact
 (1) = superseded type designation or part number
 (A) = For emergency replacement purposes where crimp tool for Category "C" is not available.
 (B) = To be used on original equipment only. Not to be stocked.
 (C) = To be specified where Military crimp tool is available.

BNC CONNECTOR SERIES

PART NUMBER	① FORMER PART	CONNECTOR TYPE & CABLE TYPE USED WITH	ENGINEERING DATA
M39012/16 -0001 -0002 -0003 -0011 -0018	UG-88/U UG-260/U UG-1033/U	Plug (m), Category "A", for cables, -- RG-58, 223, 141, 142/U RG-59, 62, 71, 140, 210/U RG-122/U RG-303/U RG-302/U	(A)
M39012/16 -0004 -0005 -0006 -0007 -0008 -0009 -0012 -0019	M23329/3-01 M23329/3-02 M23329/3-03 M23329/3-04 M23329/3-05 M23329/3-06	Plug (m), Category "B", for cables, -- RG-58/U RG-223/U RG-141, 303/U RG-142/U RG-59, 62, 140, 210/U RG-122/U RG-71/U RG-302/U	(B)

MIL-HDBK-216
SECTION 3A
10 March 1972

BNC CONNECTOR SERIES

PART NUMBER	① FORMER PART	CONNECTOR TYPE & CABLE TYPE USED WITH	ENGINEERING DATA
M39012/16 -0013 -0014 -0015 -0016 -0017 -0020		Plug (m), Category "C", for cables, -- RG-58, 141, 303/U RG-223, 142/U RG-59, 62, 140, 210/U RG-122/U RG-71/U RG-302/U	Ⓒ All captivated contacts
M39012/17 -0001 -0002 -0003 -0011 -0018	(cable jack) UG-89/U UG-261/U UG-1056/U	Plug (f), Category "A", for cables, -- RG-58, 223, 141, 142/U RG-59, 62, 71, 140, 210/U RG-122/U RG-303/U RG-302/U	Ⓐ
M39012/17 -0004 -0005 -0006 -0007 -0008 -0009 -0012 -0019	(cable jack) M23329/3-08 M23329/3-09 M23329/3-10 M23329/3-11 M23329/3-12 M23329/3-13	Plug (f), Category "B", for cables, -- RG-58/U RG-223/U RG-141, 303/U RG-142/U RG-59, 140, 62, 210/U RG-122/U RG-71/U RG-302/U	Ⓑ
M39012/17 -0013 -0014 -0015 -0016 -0017 -0020	(cable jack)	Plug (f), Category "C", for cables, -- RG-58, 141, 303/U RG-223, 142/U RG-59, 62, 140, 210/U RG-122/U RG-71/U RG-302/U	Ⓒ All captivated contacts
M39012/18 -0001 -0002 -0003 -0011 -0018	(panel jack) UG-262/U UG-291/U UG-1055/U	Receptacle (f), Category "A", for cables, -- RG-59, 62, 71, 140, 210/U RG-58, 223, 141, 142/U RG-122/U RG-303/U RG-302/U	Ⓐ Rear-Flange-
M39012/18 -0004 -0005 -0006 -0007 -0008 -0009 -0012 -0019	(panel jack) UG-1802/U UG-1803/U UG-1814/U UG-1811/U UG-1801/U UG-1793/U	Receptacle (f), Category "B", for cables, -- RG-58/U RG-223/U RG-141, 303/U RG-142/U RG-59, 62, 140, 210/U RG-221/U RG-71/U RG-302/U	Ⓑ Rear-Flange-

MIL-HDBK-216
SECTION 3A
10 March 1972

BNC CONNECTOR SERIES

PART NUMBER	① FORMER PART	CONNECTOR TYPE & CABLE TYPE USED WITH	ENGINEERING DATA
M39012/18 -0013 -0014 -0015 -0016 -0017 -0020	(panel jack)	Receptacle (f), Category "C", for cables, -- RG-58, 141, 303 /U RG-223, 142/U RG-59, 62, 140, 210/U RG-122/U RG-71/U RG-302/U	Ⓒ Rear-Flange-Mtd All captive contacts
M39012/19 -0001 -0002 -0010 -0011 -0018	(panel jack) UG-909/U UG-910/U	Receptacle (f), Category "A", for cables, -- RG-58, 223, 141, 142/U RG-59, 62, 71, 140, 210/U RG-122/U RG-303/U RG-202/U-	Ⓐ Rear-Jam-Nut- Mtd
M39012/19 -0003 -0004 -0005 -0006 -0007 -0008 -0012 -0019	(panel jack) M23329/3-15 M23329/3-16 M23329/3-17 M23329/3-18 M23329/3-19 M23329/3-20	Receptacle (f), Category "B", for cables, -- RG-58/U RG-223/U RG-141, 303/U RG-142 /U RG-59, 62, 140, 210 /U RG-122/U RG-71/U RG-302/U	Ⓑ Rear-Jam-Nut- Mtd
M39012/19 -0013 -0014 -0015 -0016 -0017 -0020	(panel jack)	Receptacle (f), Category "C", for cables, -- RG-58, 141, 303/U RG-223, 142/U RG-59, 62, 140, 210/U RG-122 /U RG-71/U RG-302/U	Ⓒ Rear-Jam-Nut- Mtd All captive contacts
M39012/20 -0001 -0008	UG-913/U	Plug (m), Rt Angle, Category "A", for cables, -- RG-58, 223, 141, 142/U RG-302/U	Ⓐ
M39012/20 -0002 -0003 -0004 -0005 -0009	UG-1812/U UG-1813/U	Plug (m), Rt Angle, Category "B", for cables, -- RG-58/U RG-223/U RG-141, 303/U RG-142/U RG-302 /U	Ⓑ
M39012/20 -0006 -0007 -0010		Plug (m), Rt Angle, Category "C", for cables, -- RG-58, 141, 303/U RG-223, 142/U RG-302/U	Ⓒ All captive contacts

MIL-HDBK-216
SECTION 3A
10 March 1972

BNC CONNECTOR SERIES

PART NUMBER	① FORMER PART	CONNECTOR TYPE & CABLE TYPE USED WITH	ENGINEERING DATA
M39012/21 -0001 -0002 -0003	UG-625/U UG-1094/U	Receptacle (f) 0.441 "D" mtg hole in .130 panel 0.382 "D" mtg hole in .260 panel 0.441 "D" mtg hole in .260 panel	Front-Jam-Nut Not for new des
M39012/22 -0001	UG-290/U	Receptacle (f) Flange Mtd in .149 panel	Rear-Flange M
M39012/23 -0001 -0002	UG-1098 /U UG-1174 /U	Receptacle (f) Rt angle, jam nut 0.382 "D" mtg hole in .260 panel 0.441 "D" mtg hole in .130 panel	Front-Jam-Nut
M39012/24 -0001 -0002	UG-911/U UG-912/U	Receptacle (f) Hermetic Sealed 0.505 "D" mtg hole in .260 panel 0.380 "D" mtg hole in .260 panel	Jam Nut Mtd Rear Mtd Front Mtd

PROPOSED

"TNC" CONNECTOR SERIES

Versions covered under MIL-C-39012

FSC-5935

Accommodates small RF cables in the 0.150 to 0.250 inch O.D. size range

Coupling Type	Threaded, 7/16-281
Material (body)	Brass, 1/2 hard
Material (dielectric)	Polytetrafluoroethylene
Cable Attach: Category A - Field attach by threaded clamp & solder (reusable)	
Category B - Permanent Crimp (and non-crimp) attach at factory (non-reusable)	
*Category C - Permanent Crimp with Military tool (non-reusable)	
Max. Oper Voltage	500 Volts rms
Frequency Range & Impedance	D.C. to 11 GHz, 50 ohms
Insertion Loss	0.20 dB at 3 GHz
RF Leakage	-60 dB at 2 to 3 GHz
Temperature Range	-65 to 165°C
Other Operational Environments	Vibration, moisture, 70,000 ft altitude

*Do not procure until Military crimp tool is available to users.

Explanation of symbols used in the following connector lists:

- (m) = male center contact
- (f) = female center contact
- (1) = superseded type/designation or part number
- (A) = For emergency replacement purposes where crimp tool for Category "C" is not available.
- (B) = To be used on original equipment only. Not to be stocked.
- (C) = To be specified where Military crimp tool is available.

TNC CONNECTOR SERIES

PART NUMBER	① FORMER PART	CONNECTOR TYPE & CABLE TYPE USED WITH	ENGINEERING DATA
M39012/26 -0001 -0002 -0003 -0004		Plug (m), Category "A", for cables, -- RG-58, 223, 141, 142/U RG-59, 62, 71, 140, 210/U RG-122/U RG-303/U	Ⓐ
M39012/26 -0005 -0006 -0007 -0008 -0009		Plug (m), Category "B", for cables, -- RG-58, 141, 303/U RG-223, 142/U RG-62, 210, 59, 140/U RG-122/U RG-71/U	Ⓑ
M39012/26 -0010 -0011 -0012 -0013 -0014	M23329/4 -01, -03 -02, -04 -05	Plug (m), Category "C", for cables, -- RG-58, 141, 303/U RG-223, 142/U RG-62, 210, 59, 140/U RG-122/U RG-71/U	Ⓒ All captive contacts

MIL-11DBK-216
SECTION 3
10 March 1972

TNC CONNECTOR SERIES

PART NUMBER	① FORMER PART	CONNECTOR TYPE & CABLE TYPE USED WITH	ENGINEERING DATA
M39012/27 -0001 -0002 -0003 -0004	(cable jack)	Plug (f), Category "A", for cables, -- RG-58, 223, 141, 142/U RG-59, 62, 71, 140, 210/U RG-122/U RG-303/U	Ⓐ
M39012/27 -0005 -0006 -0007 -0008 -0009	(cable jack)	Plug (f), Category "B", for cables, -- RG-58, 141, 303/U RG-223, 142/U RG-62, 210, 59, 140/U RG-122/U RG-71/U	Ⓑ
M39012/27 -0010 -0011 -0012 -0013 -0014	M23329/4 (cable jack) -07, -09 -08, -10 -11	Plug (f), Category "C", for cables, -- RG-58, 141, 303/U RG-223, 142/U RG-62, 210, 59, 140/U RG-122/U RG-71/U	Ⓒ All captive contacts
M39012/28 -0001 -0002 -0003 -0004	(panel jack)	Receptacle (f), Category "A", for cables, -- RG-58, 223, 141, 142/U RG-59, 62, 71, 140, 210/U RG-122/U RG-303/U	Ⓐ Rear-Jam-Nt
M39012/28 -0005 -0006 -0007 -0008 -0009	(panel jack)	Receptacle (f), Category "B", for cables, -- RG-58, 141, 303/U RG-223, 142/U RG-62, 210, 59, 140/U RG-122/U RG-71/U	Ⓑ Rear-Jam-Nt
M39012/28 -0010 -0011 -0012 -0013 -0014	M23329/4 (panel jack) -13, -15 -14, -16 -17	Receptacle (f), Category "C", for cables, -- RG-58, 141, 303/U RG-223, 142/U RG-62, 210, 59, 140/U RG-122/U RG-71/U	Ⓒ Rear-Jam-Nt All captive contacts
M39012/29 -0001 -0002 -0003 -0004	(panel jack)	Receptacle (f), Category "A", for cables, -- RG-58, 223, 141, 142/U RG-59, 62, 71, 140, 210/U RG-122/U RG-303/U	Ⓐ Rear-Flange
M39012/29 -0005 -0006 -0007 -0008 -0009	(panel jack)	Receptacle (f), Category "B", for cables, -- RG-58, 141, 303/U RG-223, 142/U RG-62, 210, 59, 140/U RG-122/U RG-71/U	Ⓑ Rear-Flange

FUNCTIONAL DIAGRAM BNC SERIES

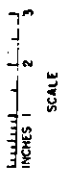
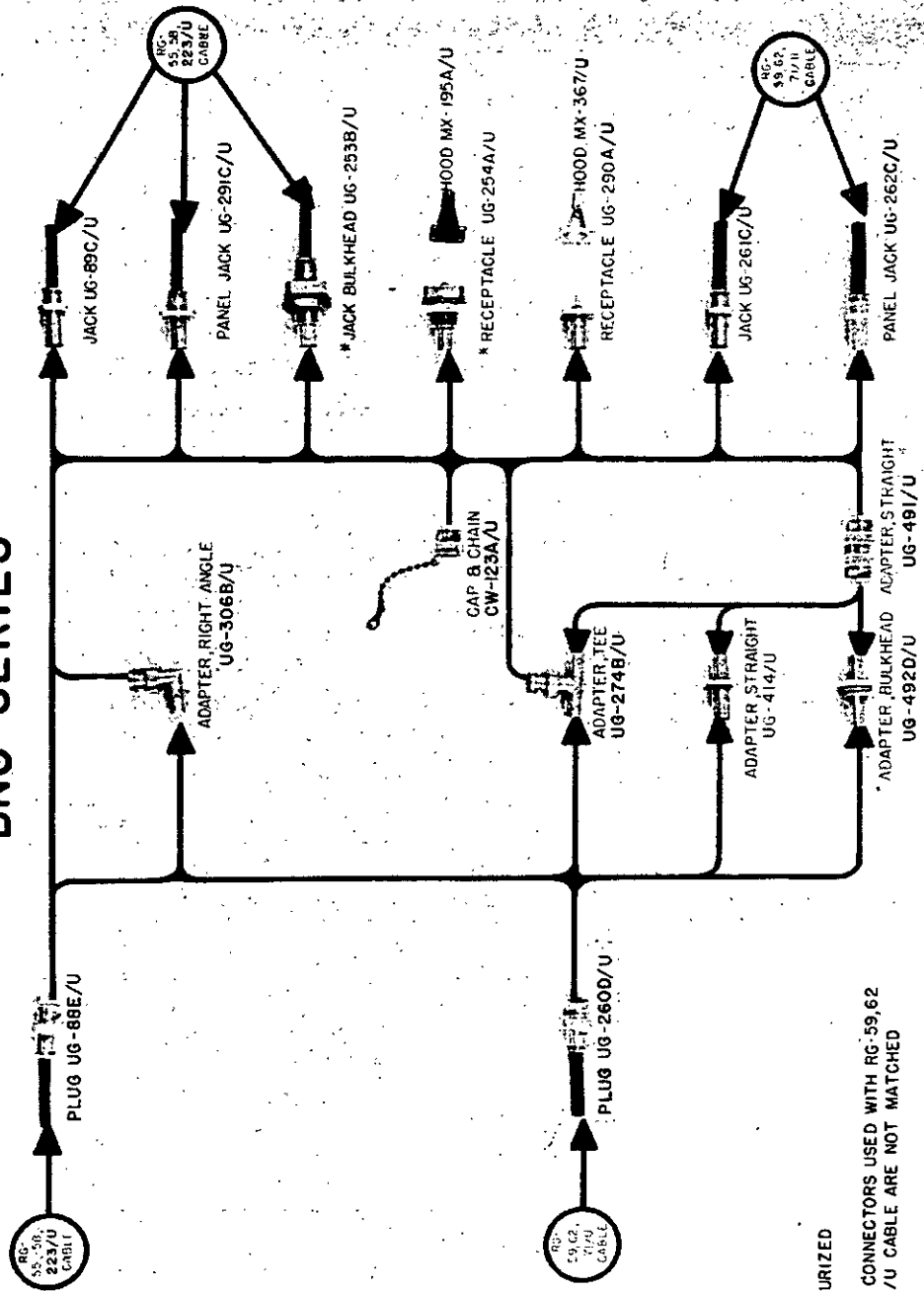

* PRESSURIZED
NOTE: CONNECTORS USED WITH RG-59, 62
AND 71/U CABLE ARE NOT MATCHED

MIL-HDBK-216
SECTION 3A
10 June 1970

C CONNECTOR SERIES

The connectors described in this part are medium-size weatherproof connectors employing a bayonet-type coupling, a metal-to-metal cable clamp, and polytetrafluoroethylene dielectric. They have a nominal impedance of 50 ohms, a maximum peak voltage rating of 1,500 volts, and a practical frequency limit of 10,000 megacycles.

These connectors are similar to series N connectors in that they are designed for use with medium size cable. These connectors are to be used by Departments of the Navy and Air Force and their contractors in preference to HN, QDS, and UHF series connectors wherever practicable. Where a more positive screw coupling is required, the SC series (threaded coupling) may be used.

C CONNECTOR SERIES

Type	Functional Description ^{1/}	For use with cable types	Engineering data
UG-566A/U	Adapter, tee (F-M-F)		Replaces UG-566/U
UG-567A/U	Adapter, right-angle (M-F)		Replaces UG-567/U
UG-568/U	Receptacle, panel		
UG-569A/U	Receptacle, bulkhead		Replaces UG-569/U; 3/4-inch thd. mounting in "D" hole.
UG-570A/U	Receptacle, bulkhead	RG-8, 9, 213 & 214, 216/U	Replaces UG-570/U; 3/4-inch thd. mounting in "D" hole.
UG-571A/U	Panel Jack	RG-8,9,213 & 214/U	Replaces UG-571/U
UG-572A/U	Jack	RG-8, 9, 213 & 214, 216/U	Replaces UG-572/U
UG-573B/U	Plug	RG-8,9,213 & 214/U	Replaces UG-573 & 573A/U
UG-626B/U	Plug	RG-5, 6, & 212/U	Replaces UG-626 & 626A/U
UG-627B/U	Plug	RG-59, 62, 71/U	Replaces UG-627, & 627A/U
UG-629A/U	Panel Jack	RG-5, 6/U & 212/U	Replaces UG-629/U
UG-630A/U	Receptacle, bulkhead	RG-5, 6/U & 212/U	Replaces UG-630/U; 3/4-inch thd. mounting in "D" hole.
UG-631A/U	Receptacle	RG-59, 62, 71/U	Replaces UG-631/U; 5/8-inch thd. mounting in "D" hole.
UG-633A/U	Jack	RG-5, 6, & 212/U	Replaces UG-633/U
UG-642A/U	Adapter (M-M)		Replaces UG-642/U
UG-643/U	Adapter (F-F)		
UG-701/U	Adapter, bulkhead, pressurized (F-F)		3/4-inch thd. mounting in "D" hole.
UG-704A/U	Receptacle, bulkhead	RG-55,58 & 223/U	Replaces UG-704/U; 5/8-inch thd. mounting in "D" hole
UG-705/U	Receptacle, bulkhead pressurized		3/4-inch thd. mounting in "D" hole.

SUPERSEDES PAGE 3.32 OF 18 MAY 1965

3.32

☆U.S. GOVERNMENT PRINTING OFFICE: 1968 - 505-033/91648

TNC CONNECTOR SERIES

PART NUMBER	① FORMER PART	CONNECTOR TYPE & CABLE TYPE USED WITH	ENGINEERING DATA
M39012/29 -0010 -0011 -0012 -0013 -0014	(panel jack)	Receptacle (f), Category "C", for cables, -- RG-58, 141, 303/U RG-223, 142/U RG-62, 210, 59, 140/U RG-122/U RG-71/U	Ⓒ Rear-Flange Mtd All captive contacts
M39012/30 -0001 -0002 -0003 -0004		Plug (m), Rt Angle, Category "A", for cables, -- RG-58, 223, 141, 142/U RG-59, 62, 71, 140, 210/U RG-122/U RG-303/U	Ⓐ
M39012/30 -0005 -0006 -0007 -0008 -0009		Plug (m), Rt Angle, Category "E", for cables, -- RG-58, 141, 303/U RG-223, 142/U RG-62, 210, 59, 140/U RG-122/U RG-71/U	Ⓑ
M39012/30 -0010 -0011 -0012 -0013 -0014		Plug (m), Rt Angle, Category "C", for cables, -- RG-58, 141, 303/U RG-223, 142/U RG-62, 210, 59, 140/U RG-122/U RG-71/U	Ⓒ All captivated contacts
M39012/31 -0001 -0002		Receptacle (f) 0.442 "D" mtg hole in 1/8" panel 0.380 "D" mtg hole in 1/4" panel	Front-Jam-Nut-Mtd
M39012/32 -0001		Receptacle (f) Flange Mtd in 1/8" panel	Rear-Flange-Mtd
M39012/33 -0001 -0002		Receptacle (f) Rt-Angle 0.437 "D" mtg hole in 1/4" panel 0.405 "D" mtg hole in 1/8" panel	Front-Jam-Nut-Mtd
M39012/34 -0001 -0002		Receptacle (f), Hermetic Sealed 0.505 "D" mtg hole in 1/8" panel 0.405 "D" mtg hole in 1/4" panel	Jam Nut Mtd Rear Mounted Front Mounted

MIL-HDBK-216
SECTION 3
10 March 1972

PROPOSED
"C" CONNECTOR SERIES

Versions covered under MIL-C-39012
FSC-5935

Accommodates medium size RF cables in the 0.300 to 0.550 inch O.D. range

Coupling Type	Bayonet
Material (body)	Brass, 1/2 hard
Material (dielectric)	Polytetrafluoroethylene
Cable Attach:	Category A - Field attach by threaded clamp & solder (reusable)
	Category B - Permanent Crimp (and non-crimp) attach at factory (non-reusable)
	*Category C - Permanent Crimp with Military tool (non-reusable)
Max. Oper Voltage	1000 Volts rms
Frequency Range & Impedance	D.C. to 11 GHz, 50 ohms
Insertion Loss	0.50 dB at 10 GHz
RF Leakage	-55 dB at 2 to 3 GHz
Temperature Range	-65 to 165°C
Other Operational Environments	Vibration, moisture, 70,000 ft altitude

*Do not procure until Military crimp tool is available to users.

Explanation of symbols used in the following connector lists:

- (m) = male center contact
- (f) = female center contact
- (I) = superseded type/designation or part number
- (A) = For emergency replacement purposes where crimp tool for Category "C" is not available.
- (B) = To be used on original equipment only. Not to be stocked.
- (C) = To be specified where Military crimp tool is available.

C CONNECTOR SERIES

PART NUMBER	① FORMER PART	CONNECTOR TYPE & CABLE TYPE USED WITH	ENGINEERING DATA
M39012/6 -0001 -0002 -0003 -0004 -0005	UG-626C/U UG-573C/U UG-707C/U UG-711C/U UG-708C/U	Plug (m), Category "A", for cables, -- RG-6, 212/U RG-213, 214, 216, 393/U RG-217/U RG-211/U RG-218/U	Ⓐ 0.870" O.D. cable- large for "C" series For armored cable
-0013 -0014	M39012/15 -0001	RG-215/U RG-59, 62, 71/U	
-0015	M39012/15 -0002	RG-58, 223/U	For small .195 and .216 O.D. cables

MIL-HDBK-216
SECTION 3
10 March 1972

C CONNECTOR SERIES

PART NUMBER	① FORMER PART	CONNECTOR TYPE & CABLE TYPE USED WITH	ENGINEERING DATA
M39012/6 -0006 -0007 -0008 -0009 -0010 -0011 -0012 -0016 -0017	M39012/15 -0003 M39012/15 -0004	Plug (m), Category "B", for cables, -- RG-143/U RG-212/U RG-213/U RG-214/U RG-393/U RG-11/U RG-165/U RG-58/U RG-223/U	ⓑ CANCELLED
M39012/6 -0018 -0019 -0020 -0021 -0022 -0023 -0024 -0025		Plug (m), Category "C", for cables, -- RG-212/U RG-213/U RG-214/U RG-393/U RG-11/U RG-165/U RG-58/U RG-223/U	ⓒ All captivated contacts
M39012/7 -0001 -0002 -0010	(cable jack) UG-572B/U UG-633B/U	Plug (f), Category "A", for cables, -- RG-213, 214, 216, 393/U RG-6, 212 /U RG-215/U	ⓐ
M39012/7 -0003 -0004 -0005 -0006 -0007 -0008 -0009	(cable jack)	Plug (f), Category "B", for cables, -- RG-313/U RG-314/U RG-393/U RG-143/U RG-212/U RG-11/U RG-165/U	ⓑ
M39012/7 -0011 -0012 -0013 -0014 -0015 -0016 -0017	(cable jack) CANCELLED	Plug (f), Category "C", for cables, -- RG-213/U RG-214/U RG-393/U RG-143/U RG-212/U RG-11/U RG-165/U	ⓒ All captivated contacts
M39012/8 -0001 -0002 -0009	(panel jack) UG-571B/U UG-629B/U	Receptacle (f), Category "A", for cables, -- RG-213, 214, 216, 393 /U RG-6, 212 /U RG-215 (armored)/U	ⓐ Rear Flange Mtd

MIL-HDBK-216
SECTION 3
10 March 1972

C CONNECTOR SERIES

PART NUMBER	① FORMER PART	CONNECTOR TYPE & CABLE TYPE USED WITH	ENGINEERING DATA
M39012/8 -0003 -0004 -0005 -0006 -0007 -0008	(panel jack)	Receptacle (f), Category "B", for cables, -- RG-213/U RG-214 /U RG-393 /U RG-143 /U RG-212 /U RG-165 /U	ⓑ Rear Flange Mtd
M39012/8 -0010 -0011 -0012 -0013 -0014 -0015	(panel jack)	Receptacle (f), Category "C", for cables, -- RG-213 /U RG-214 /U RG-393 /U RG-143 /U RG-212 /U RG-165 /U	ⓒ All captive contacts Rear Flange Mtd
M39012/9 -0001 -0002	(panel jack) UG-631B/U UG-704C/U	Receptacle (f), Category "A", for cables, -- RG-59, 62, 71/U RG-58, 223/U	Ⓐ Front Jam Nut Mtd
M39012/9 -0003 -0004	(panel jack)	Receptacle (f), Category "B", for cables, -- RG-58 /U RG-223/U	ⓑ Front Jam Nut Mtd
M39012/9 -0005 -0006	(panel jack)	Receptacle (f), Category "C", for cables, -- RG-58/U RG-223/U	ⓒ All captive contacts Front Jam Nut Mtd
M39012/10 -0001 -0005	UG-710C/U	Plug (m), Rt Angle, Category "A", for cables, -- RG-213, 214, 216, 393/U	Ⓐ
M39012/10 -0002 -0003 -0004		Plug (m), Rt Angle, Category "B", for cables, -- RG-213 /U RG-214 /U RG-393 /U	ⓑ
M39012/10 -0006 -0007 -0008		Plug (m), Rt Angle, Category "C", for cables, -- RG-213/U RG-214 /U RG-393/U	ⓒ All captive contacts

MIL-HDBK-216
SECTION 3
10 March 1972

C CONNECTOR SERIES

PART NUMBER	① FORMER PART	CONNECTOR TYPE & CABLE TYPE USED WITH	ENGINEERING DATA
M39012/11 -0001 -0002 -0010	(panel jack) UG-630B/U UG-570B/U	Receptacle (f) (P), Category "A", for cables, -- RG-6, 212/U RG-213, 214, 216, 393/U RG-215/U	Ⓐ Rear Jam Nut Mtd
M39012/11 -0003 -0004 -0005 -0006 -0007 -0008 -0009	(panel jack)	Receptacle (f) (P), Category "B", for cables, -- RG-143/U RG-212/U RG-213/U RG-214/U RG-393/U RG-11/U RG-165/U	Ⓑ Rear Jam Nut Mtd CANCELLED
M39012/11 -0011 -0012 -0013 -0014 -0015 -0016 -0017	(panel jack)	Receptacle (f) (P), Category "C", for cables, -- RG-143/U RG-212/U RG-213/U RG-214/U RG-393/U RG-11/U RG-165/U	Ⓒ All captivated contacts Rear Jam Nut Mtd CANCELLED
M39012/12 -0001	UG-568A/U	Receptacle (f), for hook-up wire Flange mtd in .188" max panel	Rear Flange Mtd
M39012/13 -0001	UG-706B/U	Receptacle (f) (P), for hook-up wire 0.383" D-mtd hole in 0.383 panel	Front Jam Nut Mtd
M39012/14 -0001 -0002	UG-569B/U UG-705B/U	Receptacle (f), for hook-up wire 0.763" D-mtg hole in .176 max panel 0.763" D-mtg hole in .176 max panel	Rear Jam Nut Mtd Rear Jam Nut Mtd Hermetic sealed
M39012/15 -0001 -0002 -0003 -0004		Plug (m) CANCELLED CANCELLED CANCELLED CANCELLED CANCELLED	Use MIL-C- 39012/6 Use -0014 Use -0015 Use -0016 Use -0017

(P) = Pressurized

"SC" CONNECTOR SERIES

Versions covered under MIL-C-39012

FSC-5935

Accommodates medium size RF cables in the 0.300 to 0.550 inch O.D. range

Coupling Type	Screw Thread, 11/16 - 24
Material (body)	Brass, 1/2 hard
Material (dielectric)	Polytetrafluoroethylene
Cable Attach: Category A - Field attach by threaded clamp & solder (reusable)	
Category B - Permanent Crimp (and non-crimp) attach at factory (non-reusable)	
*Category C - Permanent Crimp with Military tool (non-reusable)	
Max. Oper Voltage	1500 Volts rms
Frequency Range & Impedance	D.C. to 11 GHz, 50 ohms
Insertion Loss	0.15 dB at 10 GHz
RF Leakage	-90 dB/in.
Temperature Range	-65 to 165°C
Other Operational Environments	Vibration, moisture, 70,000 ft altitude

*Do not procure until Military crimp tool is available to users.

Explanation of symbols used in the following connector lists:

- (m) = male center contact
(f) = female center contact
(1) = superseded type/designation or part number
(A) = For emergency replacement purposes where crimp tool for Category "C" is not available.
(B) = To be used on original equipment only. Not to be stocked.
(C) = To be specified where Military crimp tool is available.

"SC" CONNECTOR SERIES

PART NUMBER	① FORMER PART	CONNECTOR TYPE & CABLE TYPE USED WITH	ENGINEERING DATA
M39012/35 -0001 -0002 -0003 -0004 -0005 -0014		Plug (m), Category "A", for cables, -- RG-6, 212/U RG-213, 214, 216, 393/U RG-217/U RG-211/U RG-218/U RG-215/U	Ⓐ
M39012/35 -0006 -0007 -0008 -0009		Plug (m), Category "B", for cables, -- RG-212/U RG-213, 165/U RG-214, 393/U RG-11, 144/U	Ⓑ

Note: MIL-C-39012/35 supersedes MIL-C-23329/5 in part.

MIL-HDBK-216
SECTION 3
11 March 1982

"SC" CONNECTOR SERIES

PART NUMBER	① FORMER PART	CONNECTOR TYPE & CABLE TYPE USED WITH	ENGINEERING DATA
M39012/35 -0010 -0011 -0012 -0013		Plug (m), Category "C", for cables, -- RG-212/U RG-213, 165/U RG-214, 393/U RG-11, 144/U	Ⓒ All captive contact
M39012/36 -0001 -0002 -0011 -0012 -0013 -0014	(cable jack)	Plug (f), Category "A", for cables, -- RG-213, 214, 216, 393/U RG-6, 212/U RG-215/U RG-217/U RG-211/U RG-218/U	Ⓐ
M39012/36 -0003 -0004 -0005 -0006	(cable jack)	Plug (f), Category "B", for cables, -- RG-213, 165/U RG-214, 393/U RG-212/U RG-11, 144/U	Ⓑ
M39012/36 -0007 -0008 -0009 -0010	(cable jack)	Plug (f), Category "C", for cables, -- RG-213, 165/U RG-214, 393/U RG-212/U RG-11, 144/U	Ⓒ All captive contacts
M39012/37 -0001 -0002	(panel jack)	Receptacle (f), Category "A", for cables, -- RG-59, 62, 71/U RG-58, 223/U	Front-Jam-Nut-Mtd
M39012/37 -0003 -0004	(panel jack)	Receptacle (f), Category "B", for cables, -- RG-58/U RG-223/U	Ⓑ Front-Jam-Nut-Mtd
M39012/37 -0005 -0006	(panel jack)	Receptacle (f), Category "C", for cables, -- RG-58/U RG-223/U	Ⓒ All captive contacts Front-Jam-Nut-Mtd
M39012/38 -0001 -0002 -0009	(panel jack)	Receptacle (f), Category "A", for cables, -- RG-213, 214, 216, 393/U RG-6, 212/U RG-215/U	Ⓐ Rear-Flange-Mtd
M39012/38 -0003 -0004 -0005	(panel jack)	Receptacle (f), Category "B", for cables, -- RG-213, 165/U RG-214, 393/U RG-212/U	Ⓑ Rear-Flange-Mtd

Note: MIL-C-39012/36 supersedes MIL-C-23329/5 in part.

"SC" CONNECTOR SERIES

PART NUMBER	①FORMER PART	CONNECTOR TYPE & CABLE TYPE USED WITH	ENGINEERING DATA
M39012/38 -0006 -0007 -0008	(panel jack)	Receptacle (f), Category "C", for cables, -- RG-213, 165/U RG-214, 393/U RG-212/U	Ⓒ All captive contacts Rear-Flange-Mtd
M39012/39 -0001 -0006	(panel jack)	Plug (m) Rt Angle, Category "A", for cables, -- RG-213, 214, 216, 393/U RG-215/U	Ⓐ
M39012/39 -0002 -0003	(panel jack)	Plug (m) Rt Angle, Category "B", for cables, -- RG-213, 165/U RG-214, 393/U	Ⓑ
M39012/39 -0004 -0005	(panel jack)	Plug (m) Rt Angle, Category "C", for cables, -- RG-213, 165/U RG-214, 393/U	Ⓒ All captive contact
M39012/40 -0001 -0002 -0003 -0004 -0005	(panel jack)	Receptacle (f), Category "A", for cables, -- RG-212/U RG-213, 214, 216, 393/U RG-215/U RG-217/U RG-218/U	Ⓐ Rear-Jam-Nut-Mtd
M39012/40 -0006 -0007 -0008 -0009 -0010 -0011 -0012 -0013	(panel jack)	Receptacle (f), Category "B", for cables, -- RG-212/U RG-213/U RG-214/U RG-217/U RG-165/U RG-393/U RG-11, 144/U RG-216/U	Ⓑ Rear-Jam-Nut-Mtd
M39012/40 -0014 -0015 -0016 -0017 -0018 -0019 -0020 -0021	(panel jack)	Receptacle (f), Category "C", for cables, -- RG-212/U RG-213/U RG-214/U RG-216/U RG-217/U RG-165/U RG-393/U RG-11, 144/U	Ⓒ All captive contact Rear-Jam-Nut-Mtd
M39012/41 -0001		Receptacle (f), for hook-up wire Flange Mtd in .188 max panel	Rear-Flange-Mtd

Note: MIL-C-39012/40 supersedes MIL-C-23329/5 in part.

MIL-HDBK-216
SECTION 3
10 March 1972

"SC" CONNECTOR SERIES

PART NUMBER	① FORMER PART	CONNECTOR TYPE & CABLE TYPE USED WITH	ENGINEERING DATA
M39012/42 -0001		Receptacle (f), for hook-up wire 0.408 "D" mtg hole in .260 panel	Front-Jam-Nut-Mtd
M39012/43 -0001 -0002		Receptacle (f), for hook-up wire 0.758 "D" mtg hole in .260 panel 0.758 "D" mtg hold in .260 panel	Rear-Jam-Nut-Mtd Hermetic sealed

3.33B4

MIL-HDBK-216
SECTION 3A
18 May 1965

HN CONNECTOR SERIES

The connectors described in this part are medium-size weatherproof connectors employing a screw-type coupling, metal-to-metal cable clamp and with the exception of UG-413/U and UG-560/U, polytetrafluoroethylene dielectric. They have a nominal impedance of 50 ohms. A plug is available which allows connection of this series to RG-14/U and RG-74/U, replacing the LN series.

These connectors were designed for use in high voltage applications (up to 5,000 volts peak). However, results of tests conducted by U. S. Navy Underwater Sound Laboratories, in April 1952 and May 1957, indicate that at R. F. frequencies, voltage characteristics of HN connectors are no better than those of the C and N series connectors. Consequently the HN connectors should be used for replacement purposes only.

HN CONNECTOR SERIES

Type	Functional Description ^{1/}	For use with cable types	Engineering data
UG-59E/U	Plug	RG-8 & 9/U	Replaces UG-59A, 59B, 59C & 59D/U
UG-60E/U	Jack	RG-8 & 9/U	Replaces UG-60A, 60B, 60C & 60D/U
UG-61E/U	Panel Jack	RG-8 & 9/U	Replaces UG-61A, 61B, 61C & 61D/U
UG-212C/U	Adapter, right-angle (M-F)		Replaces UG-212A, 212B & 920/U
UG-312/U	Plug	RG-81/U	
UG-333B/U	Jack	RG-17/U	Replaces UG-333 & 333A/U
UG-334B/U	Panel Jack	RG-17/U	Replaces UG-334 & 334A/U
UG-413/U	Adapter, tee (F-F-F)		Replaces UG-475/U
UG-427C/U	Panel Jack	RG-8 & 9/U	Replaces UG-427, 427A & 427B/U
UG-494A/U	Plug	RG-217/U	Replaces UG-494/U
UG-495D/U	Plug	RG-17/U	Replaces UG-495, 495A, 495B & 495C/U
UG-496/U	Receptacle		
UG-560/U	Receptacle		
UG-925B/U	Plug	RG-8, 9, 12, 116, 215/U	Replaces UG-925 & 925A/U. Includes armor clamps.
UG-926A/U	Plug	RG-211, 228/U	Replaces UG-926/U
UG-927B/U	Jack	RG-8, 9, 12, 116, 215/U	Replaces UG-927 & 927A/U; includes armor clamp.
UG-929B/U	Panel Jack	RG-8, 9, 12, 116, 215/U	Replaces UG-929 & 929A/U; Includes armor clamp
UG-930B/U	Panel Jack	RG-8, 9, 12, 116, 215/U	Replaces UG-930 & 930A/U; includes armor clamp; same as UG-929A/U except mounting plate has tapped holes in place of drilled holes.
UG-1102/U	Jack	RG-17, 219/U	Similar to UG-333B/U except armor clamp included.

MIL-HDBK-216
SECTION 3A
18 May 1965

HN CONNECTOR SERIES -- (Cont'd)

Type	Functional Description ^{1/}	For use with cable types	Engineering data
UG-1103/U	Panel Jack	RG-17, & 18/U	Similar to UG-1102/U except includes mounting plate.
UG-1109/U	Adapter, tee (M-F-M)		Mates with two UG-60D/U and one UG-59D/U
UG-1019/U	Adapter, straight (F-F)		Not weatherproof
UG-1021/U	Plug	RG-14, & 74/U	Similar to UG-494A/U except armor clamp MX-1462/U replaces clamp nut.
UG-1041A/U	Plug	RG-17, & 18/U	Replaces UG-1041/U
UG-1148/U	Plug	RG-17, & 18/U	Mates with UG-60D/U; part of cable assembly CG-1336/U
UG-1213/U	Plug	RG-8, & 9/U	Similar to UG-59B/U except center contact is captivated
UG-1214/U	Jack	RG-8, & 9/U	Similar to UG-60B/U except center contact is captivated
UG-1215/U	Panel Jack	RG-8, & 9/U	Similar to UG-61B/U except center contact is captivated
UG-1320/U	Plug	RG-8, & 9/U	Similar to UG-59E/U except construction of materials reduce effects of radiation
MX-103/U	Tapering tool		
MX-564A/U	Armor Clamp	RG-10, & 12/U	Replaces MX-564/U

^{1/}Sex of contacts is indicated by the letters "F" and "M".

MIL-HDBK-216
SECTION 3A
18 May 1965

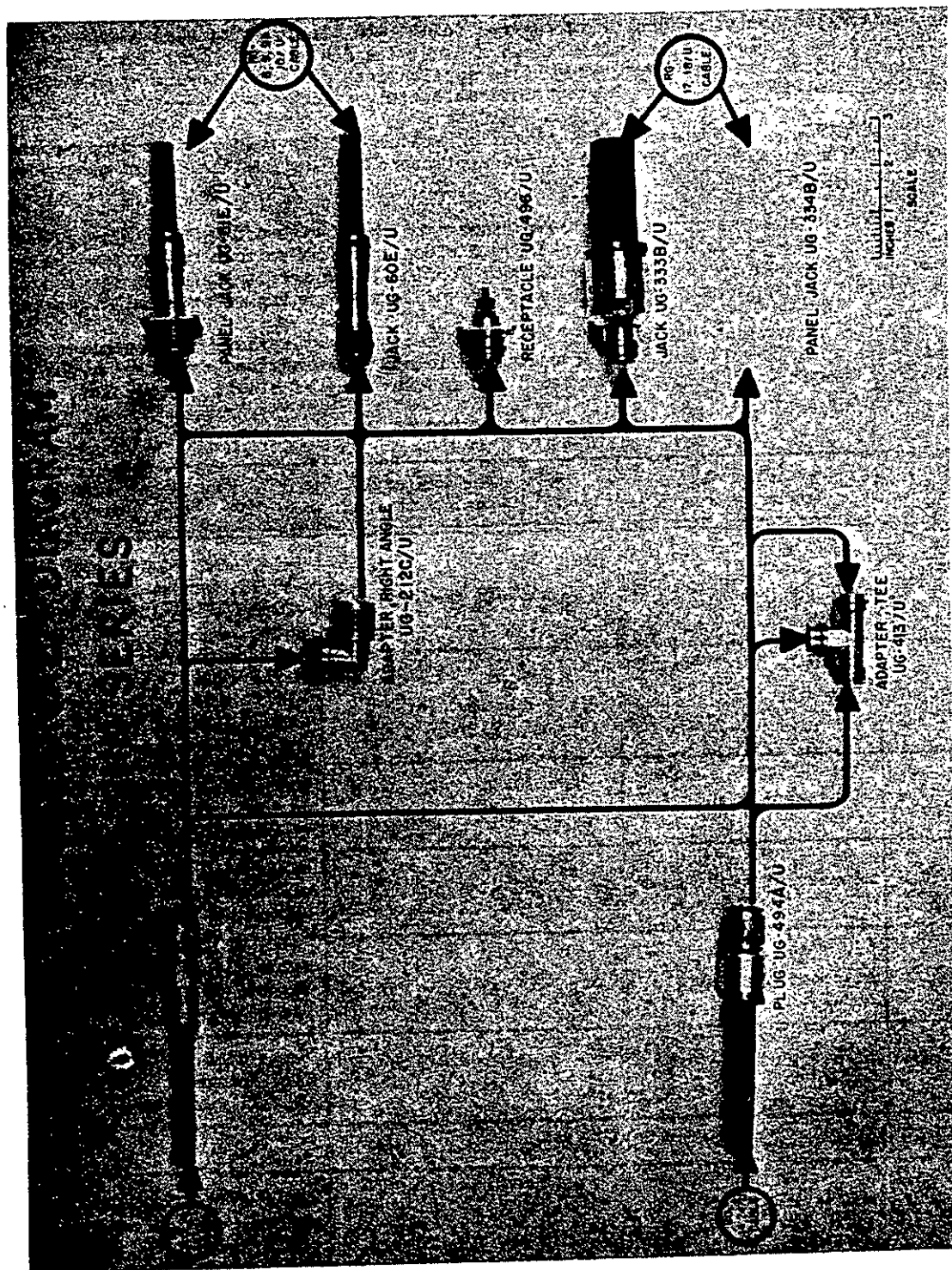

MIL-HDBK-216
SECTION 3A
18 May 1965

LC CONNECTOR SERIES

The connectors listed in this part are large-size weatherproof connectors employing a screw-type coupling. They have nominal impedance of 50 ohms and a practical frequency limit of 1,000 megacycles. With appropriate preparation, they may be used with cable RG-17/U as a low-voltage or high-voltage assembly. Where it is desired to operate plug UG-154A/U as a low-voltage connector, the cable dielectric is butted flush against the dielectric in the mating connector. Where plug UG-154A/U is used for high voltage applications a counter-boring operation is performed with special tool TL-326/U on the end of the cable dielectric.

For cable RG-19/U, the connectors indicated are all of the high-voltage type; consequently a counter-boring operation on the end of the dielectric in plug UG-156A/U must always be performed with special tool TL-325/U.

The peak voltage rating for the low-voltage types used with cable RG-17/U is 5,000 and 10,000 for the high-voltage types with counter-bored dielectric. The voltage rating for the connectors for Cable RG-19/U is in excess of 10,000. Dow Corning No. 4 ignition sealing compound, or approved equal, should always be used on the faces of the dielectric mating parts on all of these connectors.

Since the improved versions of the plugs and receptacles listed in this section generally will not mate with the old versions of Adapters listed, it is advised to refer to the "Engineering Data" column for matability of improved and old versions of plugs, receptacles, and Adapters.

SMALL LC CONNECTOR SERIES

Type	Functional Description ^{1/}	For use with cable types	Engineering data
UG-154/U	Plug	RG-17 & -18/U	Mates with UG-155,-208,-216,-287, and -352/U; may be used with UG-155B,-208B,-216B,-287, or -352B/U; See notes 1, 2, 3.
UG-154A/U	Plug	RG-218/U & -219/U	Mates with UG-155B/U,-208B/U,-216B,-287B, and -352B/U; will not mate with UG-155,-208,-216,-287, or 352/U; See notes 1 and 2.
UG-155/U	Adapter, straight (F-F)		Mates with UG-154/U and -208/U; may be used with UG-154A/U and -208B/U; See note 3.
UG-155B/U	Adapter, straight (F-F)		Mates with UG-154A/U and -208B/U; will not mate with UG-154/U or -208/U; replaces UG-155/U, -155A/U.
UG-208/U	Adapter, right-angle (M-F)		Mates with UG-154/U and -155/U; may be used with UG-154A/U and -155B/U; See note 3.
UG-208B/U	Adapter, right-angle (M-F)		Mates with UG-154A/U and -155B/U; will not mate with UG-154/U or -155/U; replaces UG-208/U & 208A/U.
UG-215/U	Adapter, straight (F-F)		
UG-216/U	Adapter, right-angle (M-F)		Mates with UG-154/U,-287/U, and -352/U. May be used with UG-154A/U,-287B/U, and UG-352B/U. See note 3.

MIL-HDBK-216
SECTION 3A
18 May 1965

SMALL LC CONNECTOR SERIES -- (Cont'd)

Type	Functional Description ^{1/}	For use with cable types	Engineering data
UG-216B/U	Adapter, right-angle (M-F)		Mates with UG-154A/U, -287B/U and -352B/U; will not mate with UG-154/U, -287/U, or -352/U; replaces UG-216/U and -216A/U.
UG-287/U	Adapter, straight (F-F)		Mates with UG-154/U, -216/U and -352/U; may be used with UG-154A/U, -216B/U and -352B/U. See note 3.
UG-287B/U	Adapter, straight (F-F)		Mates with UG-154A/U, -216B/U and -352B/U; will not mate with UG-154/U, -216/U or -352/U; replaces UG-287/U and -287A/U.
UG-314/U	Jack	RG-82/U	Mates with UG-154A/U
UG-352/U	Receptacle		Mates with UG-154/U and UG-216/U; may be used with UG-154A/U and -216B/U. See note 3.
UG-352B/U	Receptacle		Mates with UG-154A/U and UG-216B/U; will not mate with UG-154/U or -216/U; replaces UG-352/U and -352A/U.
G-1179/U	Plug	RG-85/U & -85A/U	Incorporates a cable clamp for use with RG-85/U cable.
UG-1189/U	Plug		Used with 7/8" flexible styroflex cable.
UG-1258/U	Plug	RG-17/U & -18/U	Similar to UG-154A/U except modified for use with unarmored cables.
UG-1327/U	Jack	RG-257 & 258/U	

LARGE LC CONNECTOR SERIES

Type	Functional Description ^{1/}	For use with cable types	Engineering data
UG-156/U	Plug	RG-19/U & -20/U	Mates with UG-157/U, and -219/U; may be used with UG-157B/U and -219B/U. See note 3.
UG-156A/U	Plug	RG-220/U & 221/U	Mates with UG-157B/U and -219B/U; will not mate with UG-157/U or -219/U; replaces UG-156/U.
UG-157/U	Adapter, straight (F-F)		Mates with UG-156/U and -219/U; may be used with UG-156A/U and -219B/U. See note 3.
UG-157B/U	Adapter, straight (F-F)		Mates with UG-156A/U and -219B/U; will not mate with UG-156/U or -219/U; replaces UG-157/U, -157A/U and -170/U.

MIL-HDBK-216
SECTION 3A
18 May 1965

LARGE LC CONNECTOR SERIES -- (Cont'd)

Type	Functional Description ^{1/}	For use with cable types	Engineering data
UG-219/U	Adapter, right-angle (M-F)		Mates with UG-156/U and -157/U; may be used with UG-156A/U and -157B/U. See note 3.
UG-219B/U	Adapter, right-angle (M-F)		Mates with UG-156/U and -157/U; will not mate with UG-156/U or -157/U. Replaces UG-219/U and -219A/U.
UG-1370/U	Receptacle	RG-19, 20/U	Mates with UG-156A/U; 1-3/4 in. thd. mounting in "D" hole.

ADAPTERS - SMALL TO LARGE LC

Type	Functional Description ^{1/}	For use with cable types	Engineering data
UG-220/U	Adapter, straight (M-F)		Connects UG-154A/U to UG-157B/U
UG-240/U	Adapter, straight (F-F)		Connects UG-154A/U (Undercut) to UG-156A/U

^{1/}Sex of contacts is indicated by the letters "F" and "M".

NOTES:

1. For counterboring tools TL-325/U and TL-326/U, see drawing RE49F387.
2. For Spanner wrenches TL-322/U and TL-323/U, see drawing RE49F386.
3. All male contacts, including inner conductors of cables, when used as contacts, must be carefully tapered or rounded to avoid breaking fingers of female center contact.

MIL-HDEK-216
SECTION 3A
18 May 1965

LT CONNECTOR SERIES

The connectors listed in this section are large-size weatherproof connectors employing a screw-type coupling. They have a nominal impedance of 50 ohms, a maximum peak voltage rating of 5,000 volts, a practical frequency limit of 1,000 megacycles and are designed for use with cables RG-117/U and RG-118/U. They are similar to but not interchangeable with the "LC" series. An adapter is available which allows connection of this series to the "LC" series.

For drawings covering these connectors, see Section 18.

Type	Functional Description ₁	For use with cable types	Engineering data
UG-532A/U	Plug	RG-117, 118/U	Replaces UG-532/U. See note 1.
UG-533B/U	Adapter, straight (F-F)		Replaces UG-533/U, and -533A/U. See note 1.
UG-534B/U	Adapter, right-angle (M-F)		Replaces UG-534/U, and -534A/U. See note 1.
UG-1264/U	Adapter, right-angle (M-F)		Lightweight, operates up to 5,000 mc.
UG-1265/U	Plug	RG-117, 219/U	
UG-1305/U	Plug	RG-117/U	Aluminum alloy body; operates at frequencies up to 5,000 mc.
UG-1314/U	Receptacle	RG-117, 209, 281/U	Mates with UG-532A/U
UG-1422/U	Adapter, 45° (M-F)		Lightweight, mates with UG-1305/U

₁/Sex of contacts is indicated by the letters "F" and "M".

NOTE: For instructions for assembling these connectors, refer to drawing RE62F2000.

MIL-HDBK-216
SECTION 3A
18 May 1965

FUNCTIONAL DIAGRAM LC SERIES

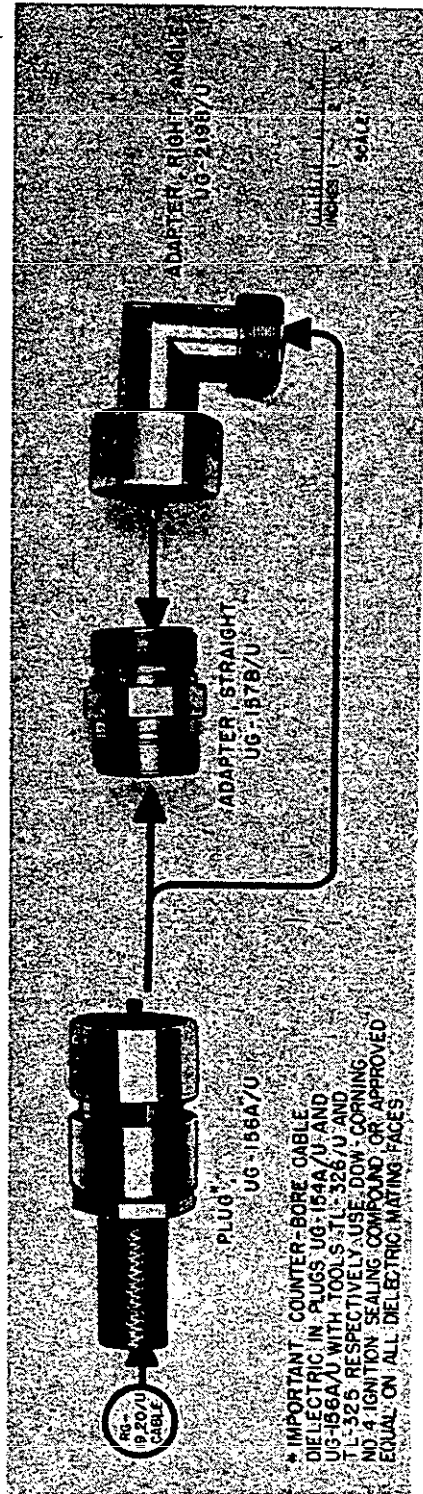
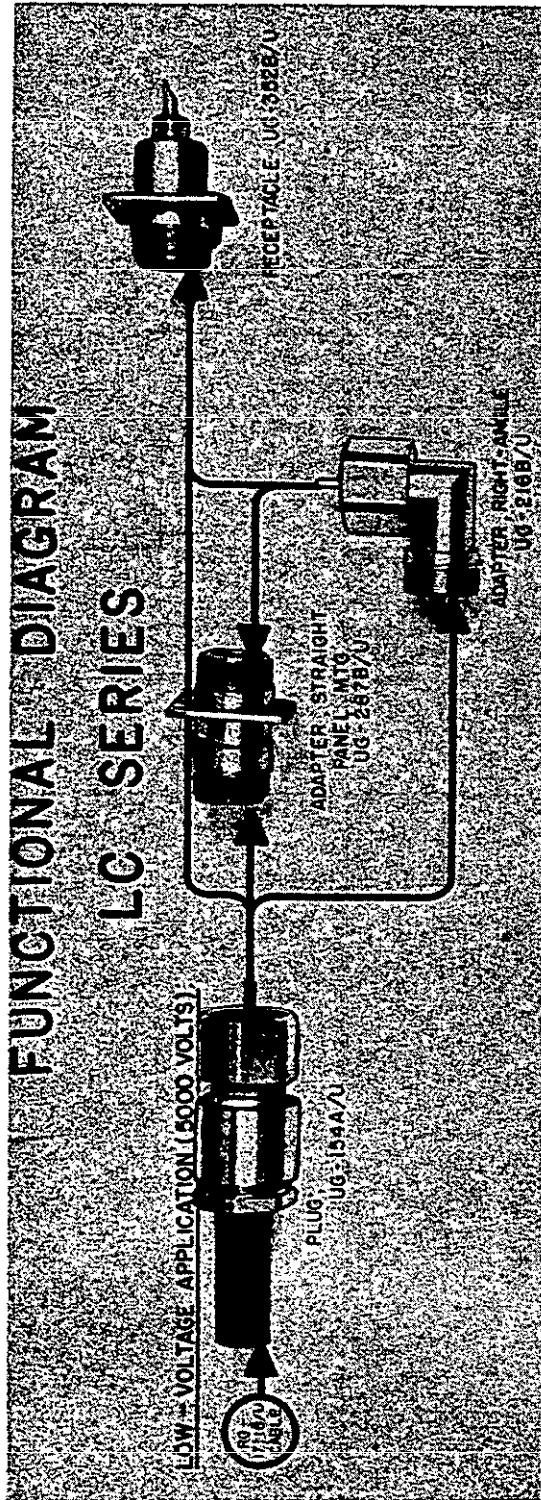

MIL-HDBK-216
SECTION 3A
18 May 1965

LN CONNECTOR SERIES

The series LN connectors are similar to but larger than Series N, and are used only with R. F. cables RG-14/U, RG-74/U and RG-94/U. They are 50-ohm and are weatherproof. The approximate peak voltage rating is 1,000 volts. These connectors have been replaced by two plugs, UG-204A/U in the N series and UG-494/U in the HN series.

LN CONNECTOR SERIES

Type	Functional Description	For use with cable types	Engineering data
UG-97B/U	Adapter, right-angle (M-F)		Replaces UG-97/U & 97A/U
UG-98A/U	Receptacle		Replaces UG-98/U
UG-100B/U	Plug	RG-217/U	Replaces UG-100, & 100A/U
UG-101B/U	Panel Jack	RG-217/U	Replaces UG-101, & 101A/U
UG-109A/U	Adapter (F-F)		Replaces UG-109/U
UG-279B/U	Jack	RG-217/U	Replaces UG-279, & 279A/U
UG-293/U	Adapter, pressurized (F-F)		
UG-530/U	Plug	RG-94, 119/U	
UG-531/U	Panel Jack		
UG-555/U	Adapter, tee (F-F-F)		
UG-921/U	Receptacle, Bulkhead pressurized		Operates up to temp. of 182° C.
UG-1022/U	Plug	RG-224/U	Similar to UG-100B/U except armor clamp MX-1462/U replaces clamp nut.
UG-1079/U	Jack	RG-224/U	Similar to UG-101B/U except nut replaced by armor clamp MX-1462/U
UG-1080/U	Jack	RG-224/U	Similar to UG-279A/U except nut replaced by armor clamp MX-1462/U
MX-1462/U	Armor clamp	RG-224/U	

^{1/} Sex of contacts is indicated by the letters "F" and "M".

MIL-HDBK-216
SECTION 3A
18 May 1965

N CONNECTOR SERIES

The connectors described in this part are medium-size weatherproof connectors employing a screw-type coupling, a metal to metal cable clamp and, with the exception of those used with cables RG-81/U and RG-82/U, polytetrafluoroethylene dielectric. They have a maximum peak voltage rating of 1,500 volts and a practical frequency limit of 10,000 megacycles. They are similar to series C connectors in that they are designed for use with medium size cables.

The N series consists of connectors having nominal impedance characteristics of 50 and 70 ohms. The 50 ohm connectors will not properly mate with the 70 ohm connectors; however, they may be used with 70 ohm cables where impedance matching is not important.

N CONNECTOR SERIES (50 Ohms)

Type	Functional Description	For use with cable types	Engineering data
UG-18D/U	Plug	RG-6, 212/U	Replaces UG-9, 15, 18, 18A, 18B, 18C, 18D/U
UG-19D/U	Panel Jack	RG-6, 212, 222/U	Replaces UG-10, 16, 19, 19A, 19B, and 19C/U
UG-20E/U	Jack	RG-6, 212, 222/U	Replaces UG-11, 17, 20, 20A, 20B, and 20C/U
UG-21F/U	Plug	RG-8, 9, 213, 214, & 216/U	Replaces UG-12, 21, 21A, 21B, 21C, and 21D/U
UG-22F/U	Panel Jack	RG-8, 9, 213, & 214/U	Replaces UG-13, 22, 22A, 22B, 22C, 23D, 23E/U
UG-23F/U	Jack	RG-8, 9, 213, 214	Replaces UG-14, 23, 23A, 23B, 23C, 22D, 22E/U
UG-27C/U	Adapter, right-angle (M-F)		Replaces UG-27, 27A, & 27B/U
UG-28A/U	Adapter, tee (F-F-F)		Replaces UG-28/U
UG-29B/U	Adapter, straight (F-F)		Replaces UG-29, & 29A/U
UG-30E/U	Adapter, bulkhead, pressurized (F-F)		Replaces UG-30, 30A, 30B, 30C, 30D/U 5/8-inch in thd mounting in single hole.
UG-57B/U	Adapter, straight (M-M)		Replaces UG-57, & 57A/U
UG-58A/U	Receptacle		Replaces UG-58/U
UG-106/U	Hood	RG-8, 12, 213, 215/U	
UG-107B/U	Adapter, tee (F-M-F)		Replaces UG-107, 107A/U
UG-159C/U	Jack, bulkhead	RG-6, 212, 222/U	Replaces UG-159, 159A, 159B. Mounts in 5/8-inch single hole

MIL-HDBK-216
SECTION 3A
18 May 1965

N CONNECTOR SERIES (50 Ohms) -- Cont'd.

Type	Functional Description	For use with cable types	Engineering data
UG-160D/U	Jack, bulkhead	RG-8, 9, 213, 214, & 216/U	Replaces UG-160, 160A, 160B & 160C/U; mounts in 5/8" single hole.
UG-167E/U	Plug	RG-17, 219/U	Replaces UG-167, 167A, 167B, 167C, and 167D/U
UG-202A/U	Adapter, right-angle panel mounting (F-F)		Replaces UG-202/U
UG-204D/U	Plug	RG-14, 217/U	Replaces UG-204, 204A, & 204B/U
UG-231/U	Receptacle		
UG-263/U	Panel Jack, pressurized		
UG-281/U	Panel jack	RG-55, 58/U	
UG-464/U	Adapter, tee (F-F-M)		2 female ends at 90° to one another and 1 male end
UG-367/U	Receptacle		
UG-483/U	Jack	RG-81/U	Replaces UG-285/U
UG-484/U	Jack	RG-82/U	
UG-486/U	Plug	RG-81/U	
UG-487/U	Plug	RG-82/U	
UG-536B/U	Plug	RG-55, 58/U	Replaces UG-188, 536, & 536A/U
UG-556B/U	Jack, bulkhead	RG-55, 58, 223/U	Replaces UG-556 & 556A/U; mounts in 5/8-inch single hole
UG-557B/U	Plug	RG-211, 228/U	Replaces UG-557/U. This connector has an armor clamp.
UG-593A/U	Panel jack	RG-59, 62 & 71/U	Replaces UG-593/U
UG-594A/U	Plug, right-angle	RG-8, 9, 213, & 214/U	Replaces UG-594/U
UG-602A/U	Jack	RG-59, 62 & 71/U	Replaces UG-602/U
UG-603A/U	Plug	RG-59, 62 & 71/U	Replaces UG-603/U
UG-680A/U	Receptacle, pressurized		Replaces UG-680/U
UG-935B/U	Panel jack	RG-215/U	Replaces UG-935, 935A, 935B/U
UG-936B/U	Jack, bulkhead		Replaces UG-936, 936A/U. Mounts in 5/8-inch single hole.
UG-940B/U	Jack	RG-8, 9, 11, 12, 13, 213, 214, 215, 216/U	Replaces UG-940, 940A, 940B/U
UG-941B/U	Plug		Replaces UG-941, 941A, 941B

MIL-HDBK-216
SECTION 3A
18 May 1965

N CONNECTOR SERIES (50 Ohms) -- Cont'd.

Type	Functional Description	For use with cable types	Engineering data
UG-982/U	Plug	RG-17, 218, 219/U	Similar to UG-167E/U except uses armor clamp
UG-997A/U	Receptacle, right-angle		Replaces UG-997/U
UG-1003/U	Plug	RG-63 & 114/U	
UG-1006B/U	Plug	RG-224/U	Similar to UG-204C/U except clamp nut replaced by armor clamp MX-1462/U
UG-1018/U	Adapter, straight (F-F)		Not weatherproof
UG-1052/U	Jack, panel	RG-55 & 58/U	Teflon insulator; not weatherproof.
UG-1095B/U	Jack, panel	RG-55, 58 & 223/U	Replaces UG-1095/U & 1095A/U
UG-1149/U	Jack		For use with 3/8" styroflex 50 ohm cable. Has dehydrating port.
UG-1150/U	Plug		For use with 3/8-inch styroflex 50 ohm cable. Has dehydrating port.
UG-1185A/U	Plug	RG-8, 9, 213, 214, & 216/U	Similar to UG-21E/U except center contact is captivated. Replaces UG-1185/U
UG-1186A/U	Jack	RG-8, 9, 213, 214, & 216/U	Similar to UG-23E/U except center contact is captivated. Replaces UG-1186/U
UG-1187A/U	Jack, panel	RG-8, 9, 213 & 214/U	Similar to UG-22E/U except center contact is captivated. Replaces UG-1187/U
UG-1195/U	Plug	RG-219/U	Similar to UG-982/U except center contact is captivated and spring finger.
UG-1266/U	Plug		For use with 7/8-inch styroflex 50 ohm cable
UG-1267/U	Jack		For use with 1/2-inch styroflex 50 ohm cable
UG-1268/U	Plug		For use with 1/2-inch styroflex 50 ohm cable
UG-1269/U	Jack		For use with 7/8-inch styroflex 50 ohm cable. Has dehydrating port.
UG-1270/U	Jack		For use with 1/2-inch styroflex 50 ohm cable. Has dehydrating port.
UG-1271/U	Plug		For use with 1/2-inch styroflex 50 ohm cable. Has dehydrating port.
UG-1272/U	Jack		For use with 7/8-inch styroflex 50 ohm cable. Has dehydrating port.

MIL-HDBK-216
SECTION 3A
18 May 1965

N CONNECTOR SERIES (50 Ohms) -- Cont'd

Type	Functional Description ^{1/}	For use with cable types	Engineering data
UG-1273/U	Plug		For use with 7/8-inch styroflex 50 ohm cable. Has dehydrating port.
UG-1281/U	Adapter (M-M)		Terminates ends of 7/8-inch styroflex cable and adapts same to UG-23A/U
UG-1282/U	Adapter (M-M)		Terminates ends of 1-5/8 inch 50 ohm styroflex cable and adapts same to UG-23B/U
UG-1283/U	Adapter (M-M)		Adapts 3-1/8 inch 50 ohms styroflex cables to 3-1/8 inch 50 ohm transmission line.
UG-1284/U	Clamp		Couples sections of 7/8-inch 50 ohm styroflex cable
UG-1285/U	Clamp		Gas type coupling for 1-5/8 inch ohm styroflex cable
UG-1286/U	Clamp		Used in forming gas tight coupling between sections of 3-1/8 inch 50 ohm styroflex cables.
UG-1308/U	Adapter (F-F)		Special adapter
UG-1309/U	Adapter, tee (F-F-F)		Special adapter
UG-1328/U	Jack	RG-257, 258/U	Includes Series N female termination
UG-1331/U	Plug	RG-254, 255/U	Includes series N female termination
MX-564A/U	Armor clamp	RG-12,215/U	Replaces MX-564/U
MX-913/U	Cap and chain		For use with female connectors
MX-1286/U	Armor clamp	RG-12,215/U	
MX-1441/U	Armor clamp	RG-219/U	Clamps armor to type N connector
MX-1462U	Armor clamp	RG-224/U	Clamps armor to type N connector

^{1/}Sex of contacts is indicated by the letters "F" and "M".

NOTE: For drawings covering these connectors, see Section 18.

MIL-HDBK-216
SECTION 3A
18 May 1965

N CONNECTOR SERIES (70 Ohms)

Type	Functional Description	For use with cable types	Engineering data
UG-91A/U	Plug	RG-6/U	Replaces UG-91/U
UG-92A/U	Jack	RG-6/U	Replaces UG-92/U
UG-93A/U	Panel Jack	RG-6/U	Replaces UG-93/U
UG-94A/U	Plug	RG-11, 13/U	Replaces UG-94/U
UG-95A/U	Jack	RG-11, 13/U	Replaces UG-95/U
UG-96A/U	Panel Jack	RG-11, 13/U	Replaces UG-96/U

NOTE 1: For drawings covering these connectors, see Section 18.

MIL-HDBK-216
SECTION 3
10 March 1972

PROPOSED

"N" CONNECTOR SERIES

Versions covered under MIL-C-39012

FSC-5935

Accommodates medium size RF cables in the 0.300 to 0.550 inch O.D. range

Coupling Type	Threaded, 5/8 - 24
Material (body)	Brass, 1/2 hard
Material (dielectric)	Polytetrafluoroethylene
Cable Attach: Category A	Field attach by threaded clamp & solder (re-useable)
Category B	Permanent Crimp (and non-crimp) attach at factory (non-re-useable)
*Category C	Permanent Crimp with Military tool (non-re-useable)
Max. Oper Voltage	1000 Volts rms
Frequency Range & Impedance	D.C. to 11 GHz, 50 ohms
Insertion Loss	0.15 dB at 10 GHz
RF Leakage	-90 dB min.
Temperature Range	-65 to 165°C
Other Operational Environments	Vibration, moisture, 70,000 ft altitude

*Do not procure until Military crimp tool is available to users.

Explanation of symbols used in the following connector lists:

- (m) = male center contact
- (f) = female center contact
- (1) = superseded type/designation or part number
- (A) = For emergency replacement purposes where crimp tool for Category "C" is not available.
- (B) = To be used on original equipment only. Not to be stocked.
- (C) = To be specified where Military crimp tool is available.

"N" CONNECTOR SERIES

PART NUMBER	① FORMER PART	CONNECTOR TYPE & CABLE TYPE USED WITH	ENGINEERING DATA
M39012/01		Plug (m), Category "A"; for cables, --	Ⓐ Captivated contact Captive contact for armored cable
-0001	UG-18/U	RG-212, 143/U	
-0002	UG-21/U	RG-213, 214, 393/U	
-0003	UG-204/U	RG-217/U	
-0004	UG-167/U	RG-218/U	
-0005	UG-1185/U	RG-213, 214, 393/U	
-0015	UG-1487/U	RG-217/U	
-0025	UG-941/U	RG-215/U	

MIL-HDBK-216
SECTION 3
10 March 1972

N CONNECTOR SERIES

PART NUMBER	① FORMER PART	CONNECTOR TYPE & CABLE TYPE USED WITH	ENGINEERING DATA
M39012/01 -0006 -0007 -0008 -0009 -0010 -0011 -0012 -0013 -0014	M23329/2 -01, -10 -02 -03 -04 -06 -07 -08 -09	Plug (m), Category "B", for cables, -- RG-212, 304/U RG-213/U RG-214/U RG-217/U RG-165/U RG-293/U RG-11, 144/U RG-216/U	Ⓑ Also substitute for /2-01 and /2-06
M39012/01 -0016 -0017 -0018 -0019 -0021 -0022 -0023 -0024	/01-0020	Plug (m), Category "C", for cables, -- RG-212, 304/U RG-213/U RG-214/U RG-217 /U RG-165 /U RG-393 /U RG-11, 144/U RG-216/U	Ⓒ All captivated contacts
M39012/02 -0001 -0002 -0003 -0031	(cable jack) UG-20 /U UG-23/U UG-1186 /U	Plug (f), Category "A", for cables, -- RG-212, 143/U RG-213, 214, 393/U RG-213, 214, 293/U RG-393, 215/U	Ⓐ Captivated contact
M39012/02 -0004 -0005 -0006 -0032	(panel jack) UG-19 /U UG-22 /U UG-1187/U	Receptacle (f), Category "A", for cables, -- RG-213, 214, 393/U RG-213, 214, 393/U RG-213, 214/U RG-393 /U	Ⓑ Captivated contact
M39012/02 -0007 -0008 -0009 -0010 -0011 -0012 -0013 -0014 -0018	M23329 (cable jack) /2 -11 /2 -12 /2 -13 /2 -14 /2 -16 /2 -17 /2 -18 /2 -19 /2 -1818	Plug (f), Category "B", for cables, -- RG-212, 143 /U RG-213 /U RG-214 /U RG-217 /U RG-165 /U RG-393 /U RG-11, 144/U RG-216 /U	Ⓑ

N CONNECTOR SERIES

PART NUMBER	① FORMER PART	CONNECTOR TYPE & CABLE TYPE USED WITH	ENGINEERING DATA
M39012/02 -0015 -0016 -0017	(panel jack) UG-1696 UG-1697 UG-1698	Receptacle (f), Category "B", for cables, -- RG-212, 143/U RG-213/U RG-216/U	ⓑ
M39012/02 -0019 -0020 -0021 -0022 -0024 -0025 -0026	(cable jack)	Plug (f), Category "C", for cables, -- RG-212, 143/U RG-213/U RG-214/U RG-217/U RG-165/U RG-393/U RG-11, 144/U	ⓒ All captivated contacts
M39012/02 -0027 -0028 -0029 -0030	(panel jack)	Receptacle (f), Category "C", for cables, -- RG-212, 143/U RG-213/U RG-214/U RG-216/U	ⓒ All captivated contacts
M39012/03 -0001 -0002 -0012	(panel jack) UG-159 UG-1537	Receptacle (f), Category "A", for cables, -- RG-6, 212, 222, 143/U RG-213, 214, 393/U RG-213, 214, 393/U	Ⓐ Rear-Jam-Nut-Mtd Captive contact
M39012/03 -0003 -0004 -0005 -0006 -0007 -0008 -0009 -0010 -0011	(panel jack) M23329/2-20 UG-1700 M23329/2-22 M23329/2-23 M23329/2-25 M23329/2-26 M23329/2-27 M23329/2-28 UG-1819	Receptacle (f), Category "B", for cables, -- RG-212, 143/U RG-213 /U RG-214/U RG-217 /U RG-165 /U RG-393/U RG-11, 144/U RG-216/U	ⓑ Rear-Jam-Nut-Mtd
M39012/03 -0013 -0014 -0015 -0016 -0018 -0019 -0020 -0021	(panel jack)	Receptacle (f), Category "C", for cables, -- RG-212, 143/U RG-213 /U RG-214 /U RG-217 /U RG-165 /U RG-393 /U RG-11, 144/U RG-216/U	ⓒ Rear-Jam-Nut-Mtd All captivated contacts

L-HDBK-216
SECTION 3
March 1972

N CONNECTOR SERIES

PART NUMBER	① FORMER PART	CONNECTOR TYPE & CABLE TYPE USED WITH	ENGINEERING DATA
139012/04 -0001	UG-680/U	Receptacle (f) for hook-up wire 0.648 Double "D" mtg hole in 1/4" panel	Hermetic sealed, Front-Jam-Nut- Mtd Rear-Flange-Mtd Bulkhead Type Rear Jam Nut Mtd
-0002 -0003	UG-58/U	Flange mtd in 0.648 Double "D" mtd hole in 1/4" panel	
139012/05 -0001	UG-594/U	Plug (m), Rt Angle, Category "A", for cables, -- RG-213, 214, 393	
139012/05 -0002 0003	UG-1707/U UG-1708/U	Plug (m), Rt Angle, Category "B", for cables, -- RG-213 RG-214	Ⓑ
139012/05 0004 0005		Plug (m), Rt Angle, Category "C", for cables, -- RG-213 RG-214	Ⓒ All captivated contacts

MIL-HDBK-216
SECTION 3A
18 May 1965

FUNCTIONAL DIAGRAM N SERIES

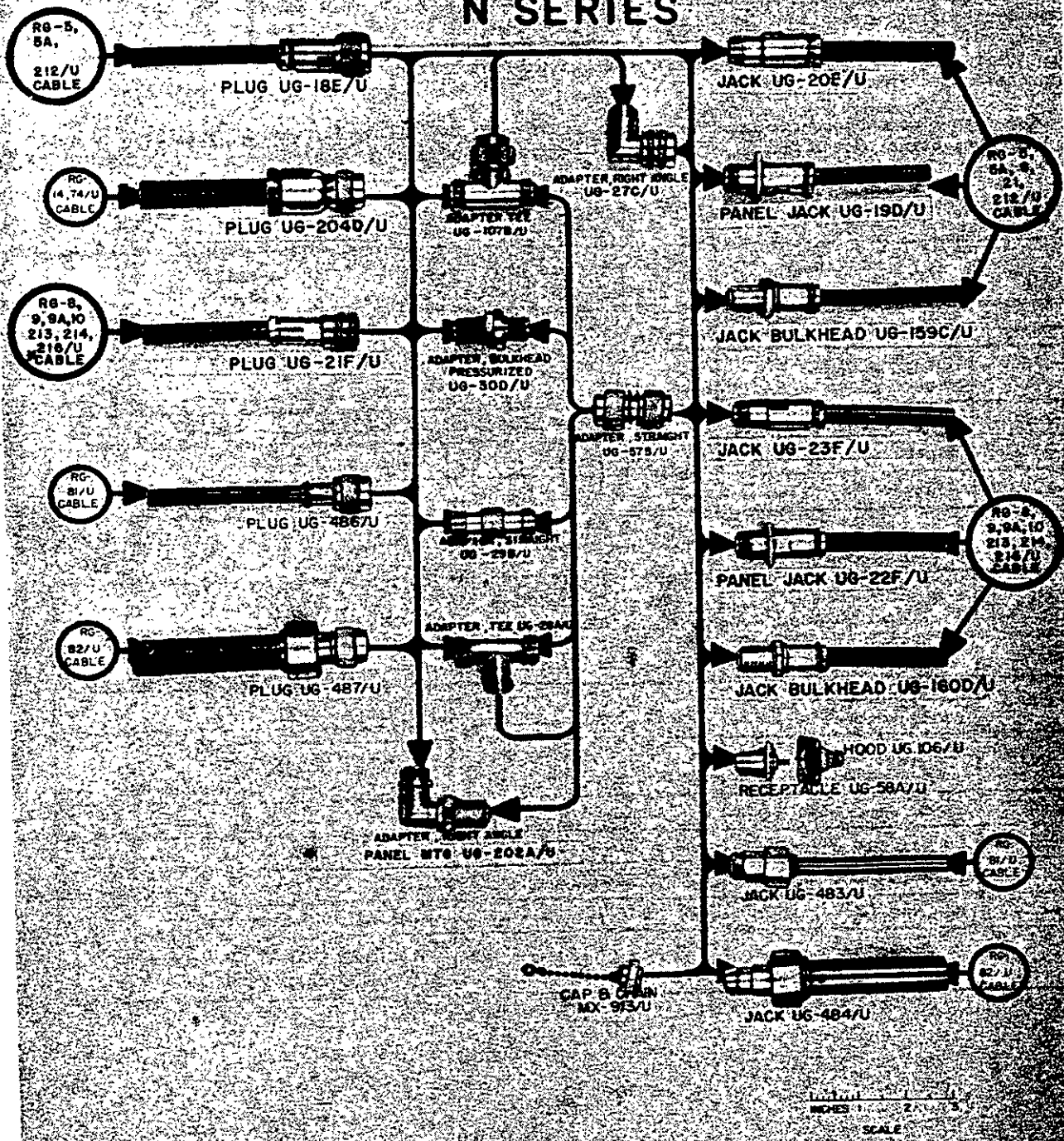

* USE ARMOR CLAMP MX-564A/U WITH RG-10/U CABLE

MIL-HDBK-216

SECTION 3A

18 May 1965

PULSE CONNECTORS, CERAMIC-INSERT TYPE

The ceramic-insert pulse connectors listed in this part are weatherproof and are commonly known as types A and B. The type A connectors have been widely used in Naval aircraft equipments. At very high altitudes, they occasionally flash-over across the ceramic insert. No damage is caused by the flash-over, and the connectors may continue to be used as soon as the voltage stress is relieved. The chief difficulty with the type A connector is the relatively poor grounding between the mating connectors. This causes excessive electrical noise where they are used near communication equipment.

The type B connectors are considered as standard for use with cable RG-27/U and RG-28/U for shipboard and Signal Corps ground equipment. They may be used at peak voltage up to 15 kilovolts. The connectors tend to leak noise.

SMALL CERAMIC-INSERT TYPE

Type	Functional Description	For use with cable types	Engineering data
UG-34/U	Plug	RG-25, 26/U	
UG-62A/U	Receptacle, (A) pressurized		Replaces UG-62/U
UG-221/U	Adapter (A)		2 female ends
UG-350/U	Receptacle (A)		Replaces UG-35/U
UG-1110/U	Adapter		Couples UG-174/U to UG-34/U

LARGE CERAMIC-INSERT TYPE

Type	Functional Description	For use with cable types	Engineering data
UG-36/U	Plug (B)	RG-27/U	
UG-37A/U	Receptacle, (B) pressurized		Replaces UG-37/U
UG-38A/U	Receptacle, (B) pressurized		Replaces UG-38, 63/U
UG-158/U	Panel Jack (B)	RG-27/U	
UG-166/U	Panel Jack (B)	RG-28/U	
UG-174/U	Plug (B)	RG-28/U	
UG-222B/U	Adapter (B)		Mechanically improved
UG-1141/U	Jack, Panel	RG-27/U	Similar to UG-37A/U except 2-24 inch thread on mounting shell

MIL-HDBK-218
SECTION 3A
18 May 1965

PULSE CONNECTORS, RUBBER-INSERT TYPE

The pulse connectors listed in this part are weatherproof, field-assembly types with molded-rubber inserts. They are designed to replace the Western electric molded cable connectors and to mate with all existing molded connectors of this type. Most of these connectors incorporate improved grounding between the cable shield and the shell of the connector. Also, the spring contact at the front end of the connector has been improved; this will greatly reduce the nose leakage commonly encountered with the existing molded connectors.

These connectors have a peak voltage rating of 5,000 volts at an altitude of 50,000 feet. They are designed principally for use with cables having an insulating Neoprene layer under the braid, such as RG-77/U and RG-78/U. They may be used with cables employing a conducting rubber under the braid such as RG-25/U, RG-26/U, and RG-64/U, provided special care is taken in assembling the connectors to these cables.

PULSE CONNECTORS, RUBBER-INSERT TYPE

Type	Functional Description	For use with cable types	Engineering data
UG-180A/U	Plug	RG-25, 26, 64, 77, 78, 88/U	Replaces UG-229/U
UG-181A/U	Panel Jack	RG-25, 26, 64, 77, 78, 88/U	Replaces UG-230/U
UG-182A/U	Jack	RG-25, 26, 64, 77, 78, 88/U	Replaces UG-228/U
UG-264/U	Receptacle	RG-25, 26, 64, 77, 78, 88/U	Replaces UG-189/U
UG-336A/U	Adapter, bulkhead, pressurized		
UG-1084/U	Adapter, tee	RG-25, 26, 88/U	150° C operating temperature 7,000 VRMS corona level at 50,000 ft altitude and 55° C temperature.
UG-1085/U	Plug, right angle		Similar to UG-181A except is right angle and mechanically improved. 150° C operating temperature 7,000 VRMS corona level at 50,000 ft altitude and 55° C temperature.
UG-1379/U	Receptacle		Pressurized internally and exter- nally. 150° C operating tempera- ture 7,000 VRMS corona level at 50,000 ft altitude and 55° C temperature.
UG-1400/U	Receptacle, bulkhead, pressurized		Mounts in 1-inch DIA thru hole. Pressurized internally and exter- nally. 150° C operating tempera- ture 7,000 VRMS corona level at 50,000 ft altitude and 55° C temperature.

MIL-EDEK-216
SECTION 3A
18 May 1965

TRIAxIAL TYPE PULSE CONNECTORS

Type	Functional Description	For use with cable types	Engineering data
UG-1291/U	Plug	RG-156/U	Watertight, triaxial corona free to 10 kv
UG-1292/U	Receptacle, pressurized		Watertight, triaxial corona free to 10 kv. Mates with UG-1291/U
UG-1293/U	Receptacle, right angle, pressurized		Watertight, triaxial corona free to 10 kv. Mates with UG-1291/U
UG-1294/U	Adapter (F-F)		Triaxial, corona free to 10 kv. Interconnects two UG-1291/U
UG-1295/U	Plug	RG-157 & 158/U	Triaxial; corona free to 14 kv.
UG-1296/U	Receptacle, pressurized		Triaxial; corona free to 14 kv mates with UG-1295/U
UG-1297/U	Receptacle, right angle, pressurized		Triaxial; corona free to 14 kv mates with UG-1295/U
UG-1298/U	Adapter (F-F)		Triaxial; corona free to 14 kv interconnects two UG-1295/U.
UG-1301/U	Receptacle, panel mounted	RG-192, 193/U	Triaxial; corona free to 15 kv
UG-1302/U	Plug	RG-192, 193/U	Triaxial; corona free to 15 kv; mates with UG-1301/U
UG-1303/U	Plug	RG-191/U	Triaxial; corona free to 25 kv; mates with UG-1304/U
UG-1304/U	Receptacle, Panel mounted	RG-191/U	Triaxial; corona free to 25 kv with UG-1303/U

MIL-HDBK-216
SECTION 3A
18 May 1965

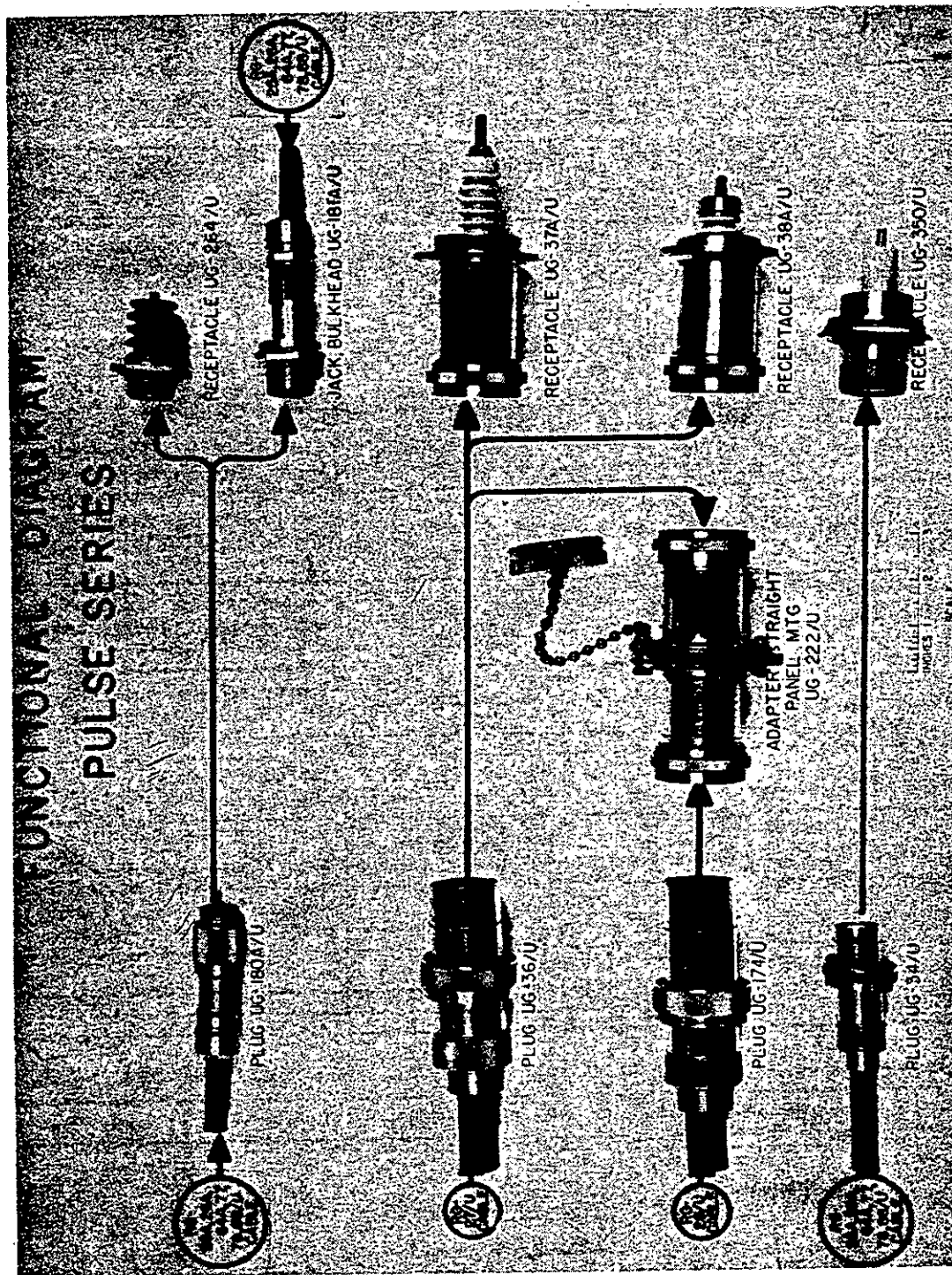

MIL-HDBK-216
SECTION 3A
18 May 1965

QDL CONNECTOR SERIES

The connectors described in this part are large-size weatherproof, quick-connect and -disconnect connectors employing a five-ball locking feature coupling, a metal-to-metal cable clamp, and polyethylene dielectric. They have a nominal impedance of 50 ohms, a maximum peak voltage rating of 9,000 volts, and a practical frequency limit of 1,000 megacycles. They are similar to series LC connectors in that they are designed for use with large-size cables.

QDL CONNECTOR SERIES

Type	Functional Description	For use with cable types	Engineering data
UG-934A/U	Adapter (F-F)		Center contact modified from closed end to spring finger design. Replaces UG-934/U.
UG-946/U	Plug	RG-17, 218/U	
UG-989A/U	Receptacle		Center contact modified from closed end to spring finger design. Replaces UG-989/U.
UG-1020B/U	Plug	RG-17, 18, 218, & 219/U	Similar to UG-946/U except has an armor clamp. Replaces UG-1020/U
UG-1061A/U	Adapter, right-angle (F-M)		Center contact modified from closed end to spring finger design. Replaces UG-1061/U.
UG-1073A/U	Jack	RG-17, 18, 218, & 219/U	Center contact modified from closed end to spring finger design. Replaces UG-1073/U.
UG-1074A/U	Jack, panel	RG-17, 18, 218, & 219/U	Center contact modified from closed end to spring finger design. Replaces UG-1074/U.
UG-1075C/U	Jack	RG-10, 12, 214, 215, & 216/U	Replaces UG-1075, 1075A & 1075B/U
UG-1076C/U	Jack, panel	RG-10, 12, 214, 215, & 216/U	Replaces UG-1076, 1076A & 1076B/U
UG-1133/U	Plug	RG-14, 74, 217, & 229/U	Similar to UG-1020/U except is used with RG-14 & 74/U cables
UG-1165/U	Receptacle	RG-85/U	
UG-1249/U	Adapter, tee (F-M-F)		
UG-1275/U	Receptacle, right-angle, panel mounted		
UG-1279/U	Plug, right angle	RG-17, & 18/U	

Box of contacts is indicated by the letters "F" and "M".

MIL-HDBK-216
SECTION 3A
18 May 1965

QDS CONNECTOR SERIES

The connectors described in this part are medium-size, weatherproof, quick-connect and -disconnect connectors employing a three-ball locking feature coupling, a metal-to-metal cable clamp, and polytetrafluoroethylene dielectric. They have nominal impedance of 50 ohms, a maximum peak voltage rating of 1,000 volts, and a practical frequency limit of 10,000 megacycles. They are similar to the series C and N connectors in that they are designed for use with medium-size cables.

QDS CONNECTOR SERIES

Type	Functional Description	For use with cable types	Engineering data
UG-967B/U	Jack	RG-8,10,213,214, 215, & 216/U	Replaces UG-967 & 967A/U
UG-968B/U	Plug	RG-8,10,213,214, 215, & 216/U	Replaces UG-968/U & 968A/U
UG-972B/U	Jack, panel	RG-8, 10, 213 & 215/U	Replaces UG-972 & 972A/U
UG-976/U	Adapter (F-F)		
UG-1010/U	Receptacle		With mounting plate
UG-1111/U	Receptacle		Mounts in 3/4-inch "D" hole.
UG-1132/U	Jack	RG-10,12,13,214, 215, & 216/U	Similar to UG-967B/U except bulkhead mounted. Replaces UG-1132/U
UG-1134/U	Plug	RG-14, 74, 217, & 224/U	Similar to UG-968A/U except for cable types
UG-1135/U	Plug	RG-14, 74, 217, & 224/U	
UG-1145/U	Adapter, bulkhead (F-F)		Similar to UG-976/U except bulkhead mounted
UG-1173/U	Adapter, tee (F-M-F)		
UG-1180/U	Receptacle		Mounts in 3/4-inch "D" hole.
UG-1210/U	Receptacle, bulkhead		Similar to UG-1165/U except female end is QDS
UG-1221/U	Adapter, right-angle (M-F)		
UG-1276/U	Receptacle, right angle		Bulkhead type
UG-1278/U	Plug	RG-8, 9, 11 & 213/U	Similar to UG-968A/U except has no provision for armor clamp
UG-1316/U	Connector switch		Mates with UG-968B/U; mounts by 4-1/8" screws.
UG-1318/U	Connector switch		Similar to UG-1316/U; mounts in single 3/4-inch thru hole.
MX-1870/U	Shield	RG-55,58,59,62, & 223/U	

MIL-STD-216
SECTION 3A
18 May 1965

QDS CONNECTOR SERIES -- Cont'd.

Type	Functional Description ^{1/}	For use with cable types	Engineering data
MX-1899/U	Hood	RG-55, 58, 59 & 62/U	
MX-1913/U	Hood	RG-8,9,213,214, & 216/U	
MX-1914/U	Hood	RG-161 & 174/U	

^{1/}Sex of contacts is indicated by the letters "F" and "M".

QL AND QM CONNECTOR SERIES

QL and QM connectors are high power, high voltage, low VSWR connectors for use with large size cables RG-217, 218, 219, 220 and 221/U where series LC, LT, HN, C and N connectors have been used in the past. The QM series designated for use with RG-217/U and the QL series for use with RG-218, 219, 220 and 221/U have a maximum VSWR of 1.27 to 1 on mated pairs of cable assemblies up to 5,000 Mc. Corona extinction values range from 6,000 volts to 60 cycle rms for the RG-217/U assemblies to 12,500 volts rms for the RG-218/U assemblies.

QL CONNECTOR SERIES

Type	Functional Description ^{1/}	For use with cable types	Engineering data
UG-1372/U	Plug	RG-189/U	
UG-1373/U	Adapter (F-F)		Adapts to UG-1372/U plug.
UG-1392/U	Plug	RG-218/U	
UG-1393/U	Plug	RG-220/U	
UG-1395/U	Plug, right-angle	RG-218/U	
UG-1396/U	Plug, right-angle	RG-220/U	
UG-1397/U	Receptacle	RG-218/U	
UG-1398/U	Receptacle	RG-220/U	
UG-1531/U	Adapter (7/8" - M)		
UG-1532/U	Adapter (7/8" - F)		
UG-1533/U	Receptacle		

^{1/}Sex of contacts is indicated by the letters "F" and "M".

QM CONNECTOR SERIES

Type	Functional Description	For use with cable types	Engineering data
UG-1394/U	Plug	RG-217/U	
UG-1399/U	Receptacle	RG-217/U	

FUNCTIONAL DIAGRAM QM AND QL SERIES

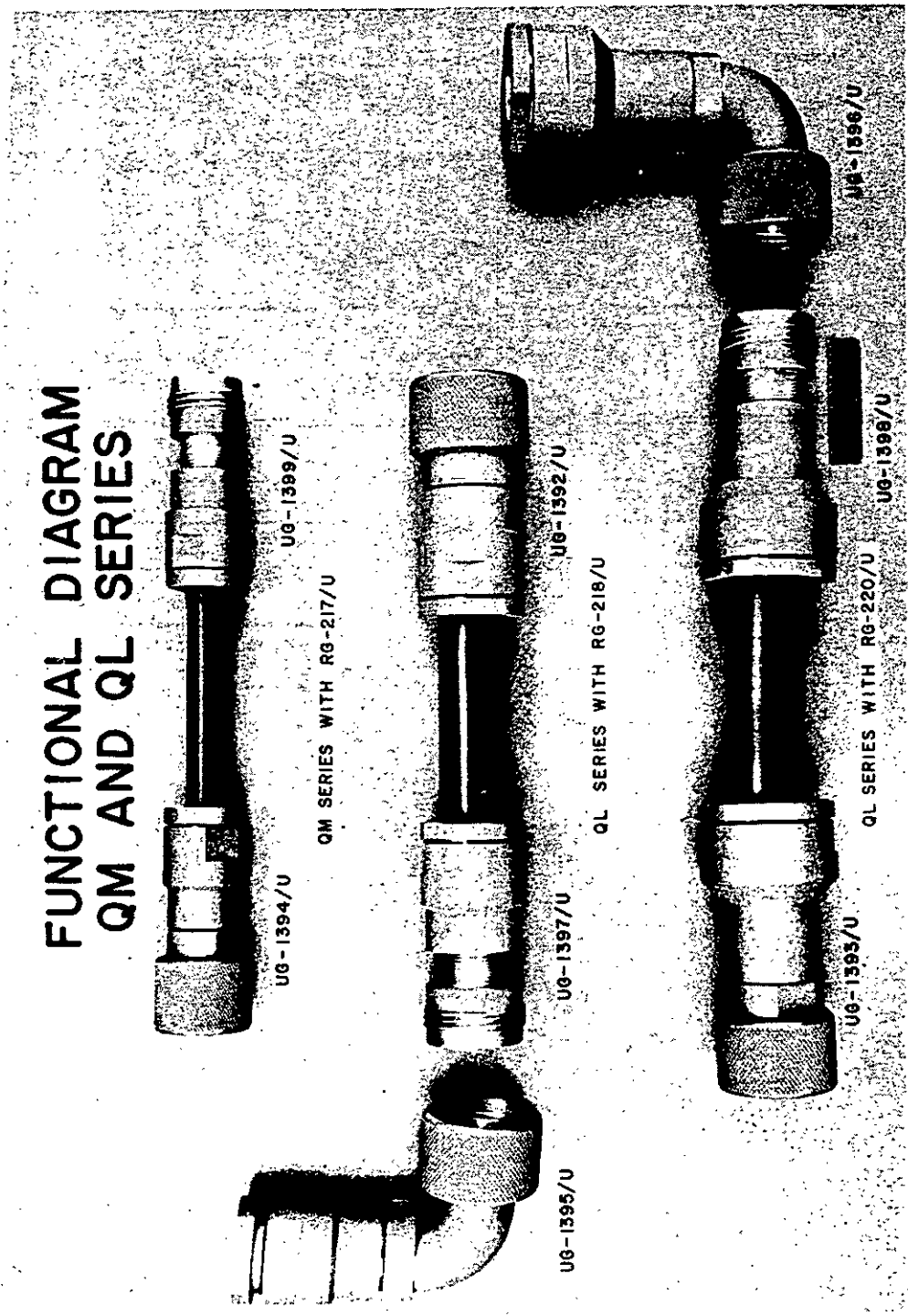

MIL-STD-216
SECTION 3A
18 May 1965

SKL CONNECTORS AND ADAPTERS

SKL connectors were originally designed to provide a connection to a Klystron tube. Various modifications were subsequently designed to provide general-purpose cable-to-cable connections.

Only Klystron connectors and SKL-to-N or SKL-to-BNC adapters should be used in new equipment. The other modification should not be used because existing standard types such as BNC and N perform the same function and are more generally available.

Since the BNC types will replace the SKL connectors and adapters for use on KLYstron tubes, SKL connectors should not be specified.

SKL CONNECTORS AND ADAPTERS

Type	Functional Description	For use with cable types	Weather-proof	Engineering data
UG-110/U	Adapter, SKL to N		No	Couples to type N female
UG-131/U	Adapter, SKL to N		No	Couples to type N male
UG-275/U	Connector, klystron	RG-212/U	No	Navy type 49270
UG-276/U	Connector, klystron, right-angle	RG-212/U	No	
UG-542/U	Adapter, SKL to N		No	Couples to type N male

MIL-HDBK-216
SECTION 3A
18 May 1965

SM CONNECTOR SERIES

The connectors described in this section are non-weatherproof and have been developed to fulfill the need for a small fitting for use with coaxial cables of 1/4" overall diameter and smaller. They may be used where electrical matching is not required.

The "SM" connectors are considerably smaller and contain fewer parts than the "BNC" series. For simplicity of design, this series employs a female contact on the plug and a male contact on the jack and receptacle. It has the advantage of a positive braid clamp and does not use the center conductor of the cable as the center contact.

The "SM" connector series is not intended to replace the "BNC" series except for internal equipment connections where weatherproofness is not required. Its useful range is presently limited to frequencies below 1,000 mc/sec and peak voltages below 100 volts.

SM CONNECTOR SERIES

Type	Functional Description ^{1/}	For use with cable types	Engineering data
UG-692/U	Plug (F)	RG-59, 62, 71/U	
UG-693/U	Plug (F)	3/32" D.O.D.	
UG-694/U	Receptacle, right angle (M)		
UG-695/U	Adapter (M-M)		
UG-696/U	Receptacle, pressurized (M)		
UG-697/U	Receptacle (M)		
UG-698/U	Jack (M)	3/32" D.O.D.	
UG-699/U	Plug (F)	RG-55, 58/U	
UG-700/U	Jack (M)	RG-55, 58/U	
UG-923/U	Jack (M)	RG-59, 62, 71/U	

^{1/} Sex of contacts is indicated by the letters "F" and "M"

MIL-HDBK-216
SECTION 3A
18 May 1965

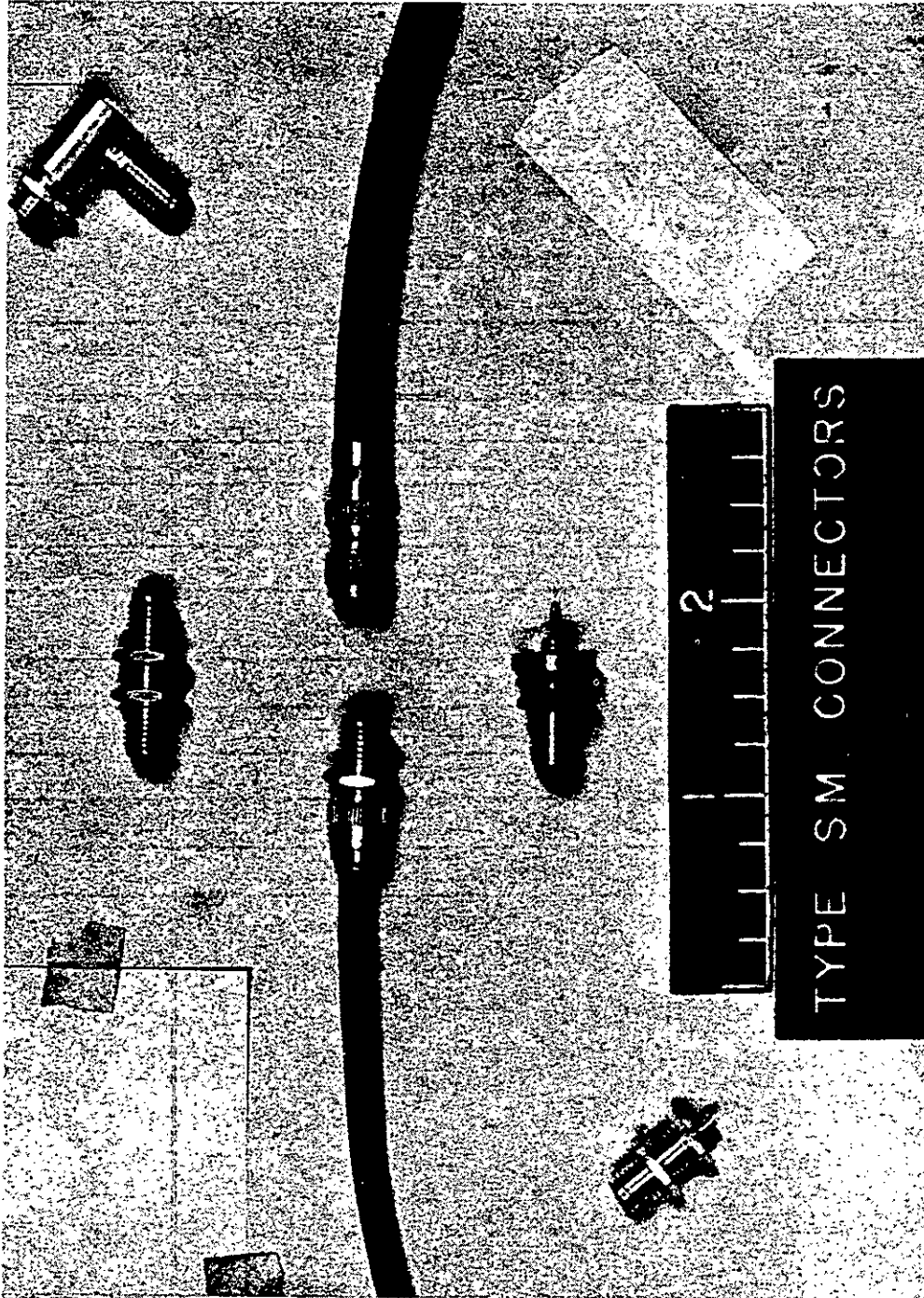

MIL-HDBK-216
SECTION 3A
18 May 1965

TPS CONNECTOR SERIES

Series TPS connectors are weatherproof and designed to produce minimum electrical discontinuities in small size solid dielectric 50 ohms coaxial cable up to a frequency of 10,000 megacycles. They are rated at 500 volts rms at sea-level. Their use is governed by the temperature limitations of their associated cables.

TPS CONNECTOR SERIES

Type	Functional description ^{1/}	For use with cable types	Engineering data
UG-1364/U	Receptacle, bulkhead	RG-58/U	Mounts in 7/16-inch "D" hole
UG-1365/U	Receptacle, bulkhead		Mounts in 7/16-inch "D" hole
UG-1366/U	Plug	RG-58/U	
UG-1367/U	Adapter (F-F)		Adapts 2 Jacks
UG-1369/U	Plug	RG-58/U	
UG-1431/U	Jack, bulkhead	RG-223/U	
UG-1412/U	Plug	RG-223/U	
UG-1368/U	Adapter, bulkhead		TPS female to BNC female
UG-1415/U	Jack	RG-58/U	
UG-1416/U	Jack	RG-223/U	
UG-1426/U	Adapter		TPS female to N female
UG-1427/U	Adapter		TPS female to N male
UG-1429/U	Adapter		TPS male to N male
UG-1443/U	Receptacle, bulkhead		
UG-1471/U	Receptacle, bulkhead, matched		

^{1/} Sex of contacts is indicated by the letters "F" and "M".

MTI-HDBK-216
SECTION 3A
18 May 1965

TWIN CONNECTOR SERIES

The connectors described in this part are known as Twin Connectors. They may be used with numerous small-and medium-sized cables. They are not constant-impedance connectors and will therefore introduce some voltage reflection. They are generally satisfactory at frequencies up to 200 megacycles and may be used with caution up to 500 megacycles. They may be used at peak voltages up to 500 volts.

These connectors are available in small twin-conductor types (weatherproof and nonweatherproof) and large twin-conductor types (nonweatherproof). The weatherproof and nonweatherproof feature is the only distinguishing feature. These two groups are not interchangeable.

TWIN CONNECTOR SERIES (Small Twin, Nonweatherproof)

Type	Functional Description	For use with cable types	Weatherproof	Engineering data
UG-102/U	Plug	RG-22/U	Yes	
UG-103A/U	Panel Jack	RG-22/U	No	Replaces UG-103/U
UG-104/U	Adapter, right-angle		No	
UG-105/U	Adapter, straight (F-F)		No	
UG-196/U	Adapter, tee (F-M-F)		No	

TWIN CONNECTOR SERIES (Small Twin, Weatherproof)

UG-106/U	Hood	RG-22/U	No	For use with UG-422/U
UG-421B/U	Plug	RG-22/U	Yes	Replaces UG-421/U
UG-422/U	Receptacle	RG-22/U	Yes	
UG-423B/U	Jack, Panel	RG-22/U	Yes	Replaces UG-423/U & 423A/U
UG-493A/U	Adapter, straight (F-F)		Yes	Replaces UG-493/U
UG-969/U	Plug	RG-86/U	Yes	
UG-981/U	Adapter, right-angle (M-F)		Yes	
UG-1253/U	Plug	RG-181/U	Yes	Mates with UG-422/U

TWIN CONNECTOR SERIES (Large Twin, Nonweatherproof)

UG-1057/U	Receptacle	RG-57/U	No	
UG-1058/U	Adapter, right-angle (M-F)		No	
UG-1059/U	Adapter, straight (M-F)		No	
UG-1060A/U	Plug	RG-57/U	Yes	Replaces UG-1060/U
UG-1556/U	Hood	RG-57/U	No	For use with UG-1057/U
UG-1363/U	Plug	RG-57/U		Used only with AT-317/BRR*

* Sex of contacts is indicated by the letters "F" and "M".

MIL-HDBK-216
SECTION 3A
18 May 1965

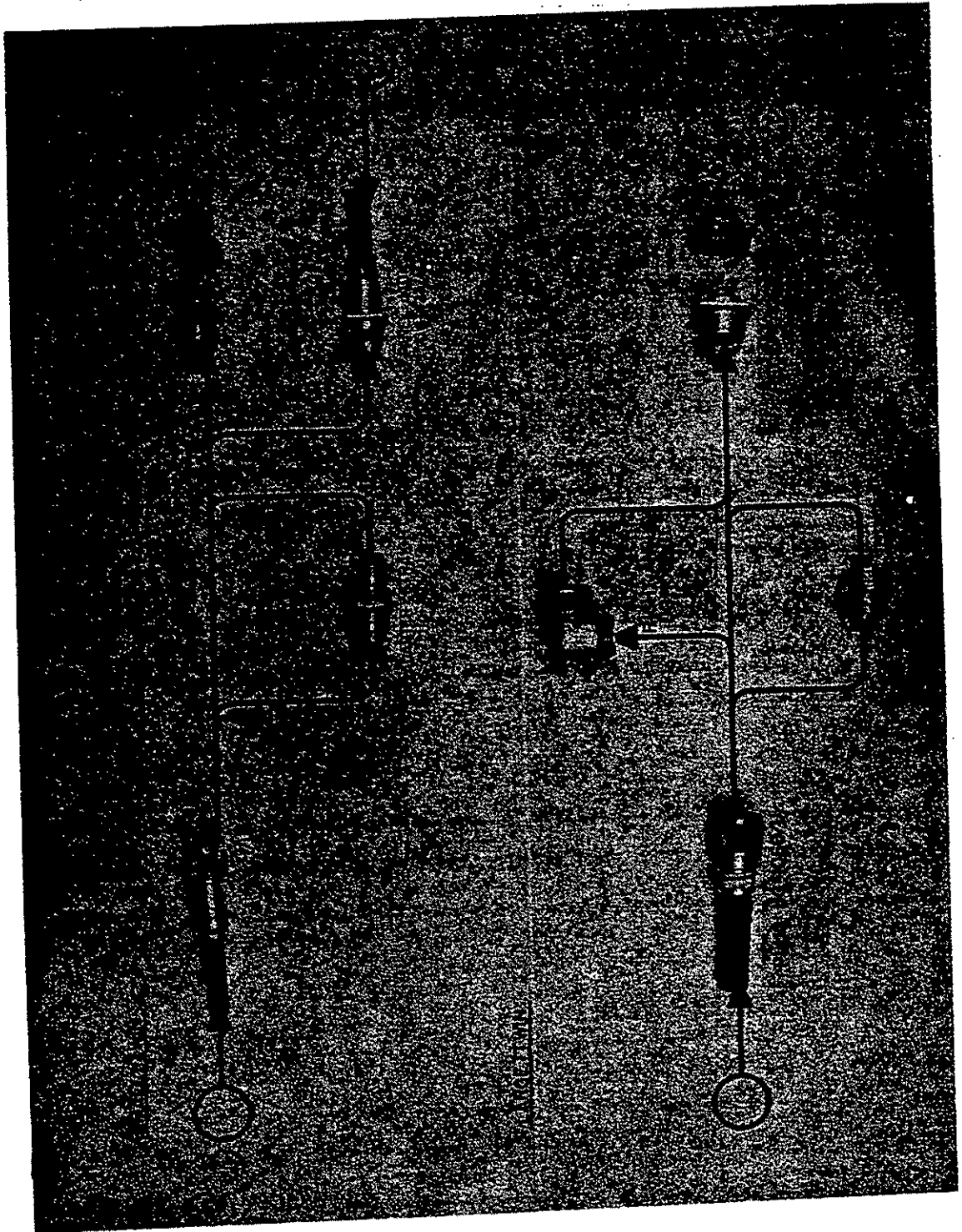

MIL-HDBK-216
SECTION 3A
18 May 1965

UHF CONNECTOR SERIES

The connectors described in this part are known as UHF Connectors. They are available in small and large coaxial types and may be used with numerous small-and medium-sized cables. They are not constant-impedance connectors and will therefore introduce some voltage reflection. They are generally satisfactory at frequencies up to 200 megacycles and may be used with caution up to 500 megacycles. They may be used at peak voltages up to 500 volts.

These connectors are general-purpose connectors, but they should not be exposed to the weather, except as indicated. These connectors should be used for replacement purposes only.

UHF CONNECTOR SERIES (Small Coaxial)

Type	Functional Description ^{1/}	For use with cable types	Engineering data
UG-73/U	Plug	RG-59/U	
UG-111/U	Plug	RG-59/U	
UG-173/U	Adapter, reducing	RG-38, 39/U	
UG-175/U	Adapter, reducing	RG-58/U	
UG-176/U	Adapter, reducing	RG-59, 62, 71/U	
UG-177/U	Hood	RG-29, 55, 58/U	
UG-203/U	Plug	RG-55, 59, 62, 71/U	
UG-223/U	Receptacle, bulkhead		
UG-224/U	Adapter, bulkhead (F-F)		
UG-239/U	Hood	RG-59/U	
UG-266/U	Receptacle, pressurized	RG-8, 9, 11, 58, 59/U	See note 1
UG-295/U	Plug	RG-8, 215/U	
UG-296/U	Receptacle	RG-8, 9, 11, 12, 13, 63, 65/U, 215/U	
UG-297A/U	Adapter, right angle (M-F)		Replaces UG-297/U
UG-298/U	Adapter, tee (F-M-F)		
UG-299/U	Adapter, straight (F-F)		
UG-300/U	Adapter, bulkhead (F-F)		
UG-307/U	Adapter, straight panel-mounting (F-F)		
UG-363/U	Adapter, bulkhead (F-F)		
UG-366/U	Hood	RG-59/U	
UG-410/U	Adapter, reducing	RG-58/U	
UG-646/U	Adapter, right-angle (M-F)		

MIL-HDBK-216
SECTION 3A
18 May 1965

UHF CONNECTOR SERIES (Small Coaxial) -- Cont'd

Type	Functional Description ^{1/}	For use with cable types	Engineering data
MX-539/U	Hood	RG-58, 59/U	
MX-543/U	Hood	RG-8,9,11/U,213/U,214/U	

^{1/}Sex of contacts is indicated by the letters "F" and "M".

NOTE 1: Requires hood MX-539/U for cables RG-58/U and RG-59/U and hood MX-543/U for cables RG-8/U, RG-9/U, and RG-11/U.

UHF CONNECTOR SERIES (Large Coaxial)

Type	Functional Description ^{1/}	For use with cable types	Engineering data
UG-357/U	Receptacle	RG-34/U	
UG-358/U	Plug	RG-34/U	
UG-359/U	Adapter, right-angle (M-F)		
UG-360/U	Adapter, straight (F-F)		
UG-372/U	Hood		Same as UG-106/U except has 2 holes on slope.
MX-1556/U	Hood	RG-34/U	

^{1/}Sex of contacts is indicated by the letters "F" and "M".

MIL-HDBK-216
SECTION 3A
18 May 1965

MINIATURE (SCREW-ON) CONNECTORS

The connectors described in this part are miniature, light weight, employing screw type couplings, and polytetrafluorethylene (teflon) dielectric. They have a nominal impedance of 50 ohms, a sea level breakdown voltage of 1500V rms, a practical frequency limit of 10,000 mc, and are designed for operation up to 200°C.

Type	Functional description	For use with cable types	Engineering data
UG-1460/U	Plug	RG-178, 196/U	Mates with UG-1462/U and UG-1463/U
UG-1461/U	Plug Right Angle	RG-178, 196/U	Mates with UG-1462/U and UG-1463/U
UG-1462/U	Plug	RG-178, 196/U	Mates with UG-1460/U Right-Angle Plug UG-1461/U
UG-1463/U	Receptacle	RG-178, 196/U	Mates with UG-1460/U and Right-Angle Plug UG-1461/U
UG-1464/U	Receptacle	MINIATURE RF CABLES	
UG-1465/U	Plug	RG-188, 316/U	Mates with UG-1467 and UG-1468/U
UG-1466/U	Plug Right-Angle	RG-188, 316/U	Mates with UG-1467/U and UG-1468/U
UG-1467/U	Plug	RG-188, 316/U	Mates with UG-1465/U and Right-Angle Plug UG-1466/U
UG-1468/U	Receptacle	RG-188, 316/U	Mates with UG-1465/U and Right-Angle Plug UG-1466/U
UG-1619/U	Receptacle	MINIATURE RF CABLES	

MIL-HDBK-216
SECTION 3A
18 May 1965

MISCELLANEOUS CONNECTORS AND ADAPTERS

The connectors and adapters listed in this part are of various types that do not fit in any of the other listings.

MISCELLANEOUS CONNECTORS AND ADAPTERS

Type	Functional Description	For use with cable types	Weather-proof	Engineering data
UG-171/U	Adapter (UHF to British)		No	Mates with UHF jack and British type 10H-365
UG-197/U	Adapter (UHF to British)		No	Mates with UHF plug and British type 10H-588
UG-288A/U	Plug (quick-disconnect)	RG-8,9,213/U 214, 215/U	No	Replaces UG-288/U. Mates with UG-289/U
UG-289/U	Adapter, bulkhead, (quick disconnect)		No	See note 1. Mates with UG-288/U
UG-347A/U	Receptacle, male (quick disconnect)		No	Replaces UG-347/U. Mates with UG-348A/U
UG-348A/U	Receptacle, female (quick disconnect)		No	Replaces UG-348/U. Mates with UG-347A/U
UG-415A/U	Plug (quick disconnect)	RG-59, 62, 71/U	No	Replaces UG-415/U. Mates with UG-416A/U
UG-416A/U	Panel jack (quick disconnect)	RG-59, 62, 71/U	No	Replaces UG-416/U. Mates with UG-415A/U
UG-478/U	Adapter	RG-8,19,81/U	Yes	Connects RG-81/U to RG-8, 10/U
UG-479/U	Adapter	RG-17, 18, 81/U	Yes	Connects RG-81/U to RG-17, 18/U
UG-480/U	Adapter	RG-81, 82/U	Yes	Connects RG-81/U to RG-82/U
UG-481/U	Adapter	RG-8, 82/U, 215/U	Yes	Connects RG-82/U to RG-8, 10/U
UG-482/U	Adapter	RG-17, 18, 82/U	Yes	Connects RG-82/U to RG-17, 18/U
UG-498/U	Receptacle, male (quick disconnect)		No	Mates with UG-499A/U
UG-499A/U	Receptacle, female (quick disconnect)		No	Replaces UG-499/U. Mates with UG-498/U
UG-501/U	Adapter	RG-81/U	Yes	Connects RG-81/U to RG-81/U
UG-502/U	Adapter	RG-82/U	Yes	Connects RG-82/U to RG-82/U
UG-503/U	Adapter	RG-17, 18 82/U	Yes	Connects RG-82/U to RG-17, 18/U
UG-504/U	Adapter	RG-18, 82/U	Yes	Connects RG-82/U to RG-18/U
UG-505A/U	Adapter	RG-17/U	Yes	Replaces UG-505/U; watertight. Connects 2 RG-17/U cables
UG-506A/U	Adapter	RG-8, 18/U	Yes	Replaces UG-506/U; watertight.

MIL-HDBK-216
SECTION 3A
18 May 1965

MISCELLANEOUS CONNECTORS AND ADAPTERS -- Cont'd

Type	Functional Description	For use with cable types	Engineering data
UG-507A/U	Adapter	RG-8, 215/U	Replaces UG-507/U; watertight
UG-526/U	Receptacle, male (quick disconnect)		Mates with UG-348A/U
UG-678/U	Plug (quick-disconnect)	RG-17, 18/U	Mates with UG-679/U
UG-679/U	Adapter (quick-disconnect)		Mates with UG-678/U
UG-931/U	Receptacle (high voltage)		Rated 5 KV. Similar to, but does not mate with series BNC connectors
UG-932A/U	Plug (High voltage)	RG-59,62,71/U	Replaces UG-932/U
UG-961A/U	Receptacle (high voltage)	RG-59,62,71/U	Replaces UG-961/U
UG-964/U	Adapter	RG-17, 18/U	
UG-975/U	Adapter	RG-17,18,82/U	Adapts RG-82/U, Pyrotenax to RG-17, 18/U
UG-978/U	Adapter (BNC to Banana Jack)		Adapts BNC female to Banana Jack
UG-987/U	Adapter		UG-290/U on one end and 2 male banana prongs on other end
UG-1016A/U	Jack (high voltage)	RG-59,62,71/U	Replaces UG-1016/U
UG-1017/U	Adapter (UHF to Banana Jack)		Adapts UHF plug PL-259 to banana jack
UG-1035/U	Adapter, straight		Includes UG-291/U and 2 male binding post banana jacks
UG-1050/U	Plug, male	RG-58/U	Quick disconnect Teflon insulation
UG-1051/U	Jack	RG-58/U	Quick disconnect Teflon insulation
UG-1062/U	Adapter, straight		Mounted by slide fit into associated part
UG-1126/U	Jack	RG-217/U,119/U	7/8" coaxial female coupling
UG-1169/U	Plug		
UG-1254/U	Plug	RG-58/U	Series "R" connector including special, loaded rugged butt contact
UG-1255/U	Plug	RG-59/U	Series "R" connector including special loaded rugged butt contact
UG-1256/U	Plug	RG-58/U	Series "R" connector including special loaded rugged butt contact

MIL-HDBK-216
SECTION 3A
18 May 1965

MISCELLANEOUS CONNECTORS AND ADAPTERS -- Cont'd

Type	Functional Description ^{1/}	For use with cable types	Engineering data
UG-1257/U	Plug	RG-59/U	Series "R" connector including special loaded rugged butt contact
UG-1259/U	Adapter (M-M)		Mates with 2 Series "R" plugs
UG-1262/U	Receptacle		Series "R" receptacle; mounting in single 3/8" DIA. hole.
UG-1263/U	Receptacle		Series "R" receptacle; mounting in single 3/8" DIA. hole.
UG-1307/U	Receptacle	RG-254 & 255/U	Includes part to facilitate bleeding the cable
UG-1321/U	Adapter		Adapts BNC plug to mixer stage-CV-822/U
UG-1324/U	Plug	RG-257 & 258/U	Includes 7/8" EIA termination
UG-1325/U	Plug	RG-252 & 253/U	Includes 7/8" EIA termination
UG-1326/U	Plug	RG-252 & 253/U	Includes 1-5/8" EIA termination
UG-1329/U	Plug	RG-254 & 255/U	Includes 1-5/8" EIA termination
UG-1330/U	Plug	RG-257 & 258/U	Includes 1-5/8" EIA termination
UG-1332/U	Adapter	RG-254 & 255/U	Bulkhead mounted; adapts two 1/4" max styroflex cable
UG-1333/U	Adapter		Adapter dielectric cables RG-252/U or RG-253/U to RG-257/U or 258/U
UG-1334/U	Adapter		Adapter dielectric cables RG-254/U or RG-255/U to RG-252/U or 253/U
UG-1335/U	Adapter		Adapter dielectric cables RG-254 & RG-255/U or RG-254/U
UG-1336/U	Adapter		Adapter dielectric cables RG-257/U or RG-258/U to RG-254/U or 255/U
UG-1337/U	Coupling		Adapter dielectric cables RG-257/U to RG-257/U or RG-255/U
UG-1380/U	Receptacle	RG-264/U	Four contact connector
UG-1381/U	Receptacle	RG-264/U	Four contact connector
	Adapter	RG-85/U	NT-491652 Adapts RG-85/U to RG-12/U. Has UHF fitting on one end.
TL-611/U	Cable dresser		QDL Taperer
MX-1599/U	Inner Conductor Assembly	RG-162/U	
MX-1600/U	Pipe flange	RG-162/U	

^{1/}Sex of contacts is indicated by the letters "F" and "M".

NOTES:

1. One end mates with plug UG-288/U; the other, with plug UG-21/U or equal.
2. For drawings covering these connectors, see Section 18.

MIL-HDBK-216
SECTION 3A
18 May 1965

END SEALS

The end seals described in this part are weatherproof cable terminations which have provisions for electrical connections to the inner and outer conductors of a cable.

END SEALS

Type	Functional Description	For use with cable types	Engineering data
MX-407B/U	End Seal	RG-17,18,218,219/U	Replaces MX-407, & 407A/U
MX-675/U	End Seal	RG-81/U	
MX-676/U	End Seal	RG-82/U	Approximately 4.5 Kv.
MX-840/U	End Seal		
MX-1057/U	End Seal	RG-17,18,218,219/U	
MX-1113/U	End Seal	RG-82/U	
MX-1169/U	End Seal	RG-85/U	
MX-1170/U	End Seal	RG-85/U	
MX-1203F/U	End Seal	RG-17,18,218,219/U	Replaces MX-1203, 1203A, 1203B, 1203C, 1203D, & 1203E/U
MX-1228/U	End Seal	RG-128/U	Air line seal
MX-1397A/U	End Seal	RG-14, 217/U	Replaces MX-1397/U
MX-1461/U	End Seal	RG-8,9,10,11,12,13, 119,120,213,214, 215,216/U	Uses Armor Clamp MX-1286/U
MX-1465/U	End Seal	RG-8,9,10,11,12,13, 63,213,214,215, 216/U	Uses Armor clamp MX-1286/U Replaces MX-498, 498A/U
MX-1490B/U	End Seal	RG-17,18,218,219/U	Replaces MX-1490, 1490A/U
MX-1530A/U	End Seal	RG-59, 62/U	Replaces MX-1530/U
MX-1531A/U	End Seal	RG-59, 62/U	Replaces MX-1531/U
MX-1554A/U	End Seal	RG-8,9,11,13,213, 214,216/U	Replaces MX-1554/U
MX-1564/U	End Seal		
MX-1598/U	End Seal	RG-162/U	
MX-1684/U	End Seal	RG-55,58,223/U	Similar to MX-1530/U except for RG-58/U
MX-1744A/U	End Seal	RG-55,58,223/U	Replaces MX-1744/U
MX-1801A/U	End Seal	RG-59,62/U	Replaces MX-1801/U
MX-1802A/U	End Seal	RG-59,62/U	Replaces MX-1802/U
MX-1884/U	End Seal	RG-55,58,223/U	Similar to MX-1802A/U except for smaller cable type
MX-1901/U	End Seal	RG-85/U	
MX-2632/U	End Seal	RG-217/U	Replaces MX-1379A/U
UG-1170/U	End Seal	RG-85,85A/U	

MIL-HDBK-216
SECTION 3A
18 May 1965

ASSEMBLY INSTRUCTIONS FOR SERIES BN CONNECTORS



	<p>Cut off vinyl jacket to correct dimension (see chart). Care should be taken to avoid nicking braid.</p>																						
	<p>Comb out braid and cut off dielectric to proper dimension (see chart). Tin center conductor. Care should be taken to avoid nicking center conductor.</p>																						
	<p>Taper braid and slide on cable clamp nut, washer, bushing and braid clamp. A non-contaminating type of plastic tape may be used to hold the braided wires in the tapered position while parts are placed in position over the jacket.</p>																						
	<p>Fold braid back smoothly over braid clamp without crossing strands and trim off excess. Check 1/8 dimension and dimension "C" against chart. Slide contact over conductor, flush against dielectric and solder securely. Remove excess solder from sides of contact. Do not damage plating.</p>																						
	<p>When using RG-59, 62, or 71/U cable, cut off and discard small diameter portion of gasket. Stretch gasket over jacket so that the jacket and gasket will butt against the braid clamp. Procedure is the same for both plug and jack assemblies.</p>																						
	<p>Slide entire assembly into body and tighten cable clamp nut securely.</p> <table border="1" data-bbox="779 1554 1315 1764"> <thead> <tr> <th>Dimension</th> <th>RG- /U Cable</th> <th>Plug</th> <th>Jack</th> </tr> </thead> <tbody> <tr> <td rowspan="2">A</td> <td>58, 58B, 58C</td> <td>7/16</td> <td>15/32</td> </tr> <tr> <td>59A, 62A, 71</td> <td>1/2</td> <td>17/32</td> </tr> <tr> <td rowspan="2">B</td> <td>58, 58B, 58C</td> <td>5/16</td> <td>11/32</td> </tr> <tr> <td>59A, 62A, 71</td> <td>3/8</td> <td>13/32</td> </tr> <tr> <td>C</td> <td>58, 58B, 58C, 59A, 62A, 71</td> <td>1/4</td> <td>9/32</td> </tr> </tbody> </table>	Dimension	RG- /U Cable	Plug	Jack	A	58, 58B, 58C	7/16	15/32	59A, 62A, 71	1/2	17/32	B	58, 58B, 58C	5/16	11/32	59A, 62A, 71	3/8	13/32	C	58, 58B, 58C, 59A, 62A, 71	1/4	9/32
Dimension	RG- /U Cable	Plug	Jack																				
A	58, 58B, 58C	7/16	15/32																				
	59A, 62A, 71	1/2	17/32																				
B	58, 58B, 58C	5/16	11/32																				
	59A, 62A, 71	3/8	13/32																				
C	58, 58B, 58C, 59A, 62A, 71	1/4	9/32																				

MIL-HDBK-216.
SECTION 3A
18 May 1965

ASSEMBLY INSTRUCTIONS FOR SERIES BNC CONNECTORS



	<p>Trim jacket: $19/64''$ for RG-59/U and RG-62/U $5/16''$ for RG-58/U and RG-71/U $21/64''$ for RG-55/U.</p>
	<p>Fray shield and strip inner dielectric $1/8''$. Tin center conductor.</p>
	<p>Taper braid and slide nut, washer, gasket and clamp over braid. Clamp is inserted so that its inner shoulder fits squarely against end of cable jacket. A non-contaminating type of plastic tape may be used to hold the braided wires in the tapered position while parts are placed in position over the jacket.</p>
	<p>With clamp in place, comb out braid, fold back smooth as shown and trim $3/32''$ from end.</p>
	<p>Slip contact in place, butt against dielectric and solder. Remove excess solder from outside of contact. Be sure cable dielectric is not heated excessively and swollen so as to prevent dielectric from entering into connector body.</p>
	<p>Push assembly into body as far as it will go. Slide nut into body and screw in place with wrench until tight. For this operation, hold cable and shell rigid and rotate nut.</p>

MIL-HDBK-216
SECTION 3A
18 May 1965

ASSEMBLY INSTRUCTIONS FOR IMPROVED SERIES BNC CONNECTORS

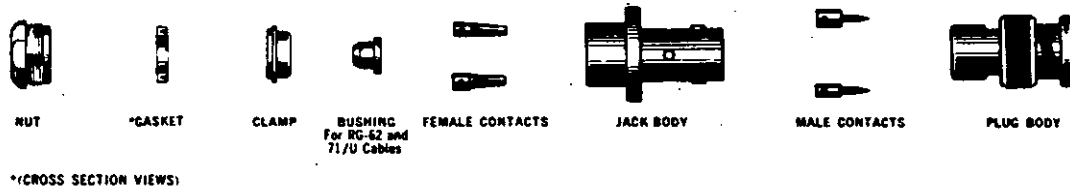

	<p>Place nut and gasket, with "V" groove toward clamp, over cable and cut jacket to dimension shown.</p>
	<p>Comb out braid and fold out. Cut cable dielectric to dimension shown. Tin center conductor, using minimum amount of heat.</p>
	<p>Pull braid wires forward and taper toward center conductor. Place clamp over braid and push back against cable jacket. A non-contaminating type of plastic tape may be used to hold the braided wires in the tapered position while parts are placed in position over the jacket.</p>
	<p>Fold back braid wires as shown, trim to proper length and form over clamp as shown. For RG-62 and 71 U type cable add bushing. Solder contact to center conductor, avoiding excessive heat which might swell cable dielectric.</p>
	<p>Insert prepared cable termination into connector body. Make sure sharp edge of clamp seats properly in gasket. Tighten nut.</p>

MIL-HDBK-216
SECTION 3A
18 May 1965

ASSEMBLY INSTRUCTIONS FOR SERIES C CONNECTORS



	<p>Place nut and gasket over cable and cut jacket to dimension "A".</p>																									
	<p>Comb out braid and fold out. Cut cable dielectric to dimension "B".</p>																									
	<p>Pull braid wires forward and taper toward center conductor. Place clamp over braid and push back against cable jacket. A non-contaminating type of plastic tape may be used to hold the braided wires in the tapered position while parts are placed in position over the jacket.</p>																									
	<p>Fold back braid wires as shown, trim to proper length and form over clamp as shown. Solder contact to center conductor. Dimension "D" should be as shown.</p>																									
	<p>Insert cable and parts into connector body. Make sure sharp edge of clamp seats properly in gasket. Tighten nut. End of contact in plug should be flush with insulator. There should be a clearance of .010" between end of contact and insulator in jack.</p> <p style="text-align: center;">DIMENSIONS</p> <table border="1"> <thead> <tr> <th>UG-/U Number</th> <th>A</th> <th>B</th> <th>C</th> <th>D (Ref.)</th> </tr> </thead> <tbody> <tr> <td>570, 571, 572, 573A, 626A, 629, 630, 710A</td> <td>5/16</td> <td>5/32</td> <td>5/32</td> <td>3/64</td> </tr> <tr> <td>628A, 632</td> <td>19/32</td> <td>7/16</td> <td>5/32</td> <td>11/32</td> </tr> <tr> <td>707A</td> <td>3/8</td> <td>13/64</td> <td>11/64</td> <td>5/64</td> </tr> <tr> <td>709A</td> <td>3/8</td> <td>7/32</td> <td>5/32</td> <td>9/64</td> </tr> </tbody> </table>	UG-/U Number	A	B	C	D (Ref.)	570, 571, 572, 573A, 626A, 629, 630, 710A	5/16	5/32	5/32	3/64	628A, 632	19/32	7/16	5/32	11/32	707A	3/8	13/64	11/64	5/64	709A	3/8	7/32	5/32	9/64
UG-/U Number	A	B	C	D (Ref.)																						
570, 571, 572, 573A, 626A, 629, 630, 710A	5/16	5/32	5/32	3/64																						
628A, 632	19/32	7/16	5/32	11/32																						
707A	3/8	13/64	11/64	5/64																						
709A	3/8	7/32	5/32	9/64																						

MIL-HDBK-216
SECTION 3A
18 May 1965

ASSEMBLY INSTRUCTIONS FOR SERIES HN CONNECTORS



*REPLACE WASHER AND GASKET IN:
UG-59B/U
UG-60B/U
UG-61B/U

	<p>Cut end of cable even. Insert cap over cable armor. Bulge armor braid by pushing armor back on cable 6". Push nut #2, washer and gasket over cable jacket. When assembling connectors with gland, be sure knife-edge is toward end of cable and groove in gasket is toward the gland.</p>
	<p>Remove vinyl jacket 1-1/8" from end of cable. For double shield cables, remove vinyl jacket 1-3/16" from end of cable.</p>
	<p>Push clamp over copper braid, flush against cable jacket. Cut exposed copper braid so that approximately 3/16" remains and fan over clamp. Trim braid even with end of taper. Cut cable dielectric 25/32" from braid. Tin exposed conductor.</p>
	<p>Solder contact pin to conductor. Do not overheat dielectric. Do not use excess solder. Wipe clean; see that dielectric is free from solder, resin and foreign material.</p>
	<p>Taper dielectric with (MX-103/U) trimming tool. When tapering dielectric of cable for plug assembly, push contact stop of tool to bottom of slot. Tool will stop cutting when shoulder of contact butts against stop. For jack assembly see that stop is at top of slot. Cable will be properly tapered when end of center contact is flush with end of trimmer body. (Omit this operation for UG-59B, -60B, -61B/U).</p>
	<p>Apply small amount of Silicone Compound on tapered surface of dielectric. Insert assembly into connector body. Tighten Nut #1 (or Nut #2 if cable is armored) securely with wrench. Straighten bulge in armor. Cut armor so that it can be clamped between Nut #2 and cap. Tighten cap securely on Nut #2 with wrench. In connectors with gland, knife-edge should cut gasket in half by tightening sufficiently.</p> <p>NOTE: When cable without armor is used, the cap and Nut #2 (Armor Clamps MX-564/U and MX-564A/U) are not required. Instead Nut #1 as supplied with connector is used and instructions pertaining to armor disregarded.</p>

MIL-HDBK-216
SECTION 3A
18 May 1965

ASSEMBLY INSTRUCTIONS FOR SERIES HN CONNECTORS UG-333/U & UG-334/U



	<p>Cut end of cable even. Push armor back out of way. Cut off vinyl jacket 1-1/2" from end of cable. Fan copper braid out. Cut off dielectric 7/8" from end. Cut off center conductor 11/16" from end.</p>
	<p>Push armor toward end and taper end of braid and armor as shown. Slide Nut on over the armor.</p>
	<p>Push armor and nut back. Slide outer sleeve on over the vinyl jacket. Slide inner sleeve over braid and under vinyl jacket until vinyl jacket touches large rim of inner sleeve. A non-contaminating type of plastic tape may be used to hold the braided wires in the tapered position while parts are placed in position over the jacket.</p>
	<p>With inner sleeve in place, trim copper braid leaving 3/16" exposed as shown.</p>
	<p>Fold copper braid back over inner sleeve and smooth. Tin center conductor using minimum heat. Holding contact with pliers, soft solder contact to center conductor. Wipe contact and dielectric clean. Slip Gasket over Inner Sleeve as shown. Slide Outer Sleeve as close as possible to Inner Sleeve.</p>
	<p>Pull armor up as far as possible. Cut off armor approximately 2" from end.</p>
	<p>Push armor back and place end of armor on the shoulder portion of Outer Sleeve as shown. Slide Nut over Outer Sleeve.</p>
	<p>Apply small amount of silicone compound to cable dielectric. Slide body into place carefully so that center conductor contact enters hole in insulator. Face of cable dielectric must fit flush against insulator. Tighten Body and Nut with wrench.</p> <p>NOTE: When cable without armor is used, disregard all instructions pertaining to armor.</p>

MIL-HDBK-216
SECTION 3A
18 May 1965

ASSEMBLY INSTRUCTIONS FOR SERIES HN CONNECTORS UG-333A/U & UG-334A/U



	<p>Cut end of cable even. Slide nut and washer #2 over armor. Cut off armor $31/32$" from end. Cut vinyl jacket $19/32$" from end.</p>
	<p>Comb out braid as shown. Cut off dielectric $3/16$" from end.</p>
	<p>Push armor back approximately 5" from end. Taper braid as shown. Slide washer #1 on jacket. Slide gasket on jacket. Slide clamp on braid. Shoulder of clamp should seat against jacket. A non-contaminating type of plastic tape may be used to hold the braided wires in the tapered position while parts are placed in position over the jacket.</p>
	<p>Trim braid $3/8$" from clamp as shown.</p>
	<p>Turn up armor radially, and press flat against washer #2. Trim off excess armor which extends beyond washer #2. Fold copper braid back on clamp. Tin center conductor using minimum heat. Soft solder contact to center conductor. Contact must be tight against cable dielectric. Wipe dielectric and contact clean.</p>
	<p>Slide body into place carefully so that contact enters hole in insulator. Face of cable dielectric must fit flush against insulator. Slide gasket and washer #1 into body. Push armor into body by straightening out bulge. Screw nut into body, then tighten body and nut with wrenches.</p> <p>NOTE: When cable without armor is used, disregard all instructions pertaining to armor.</p>

MIL-HDBK-216
SECTION 3A
18 May 1965

ASSEMBLY INSTRUCTIONS FOR SERIES HN CONNECTORS WITH CAPTIVATED CONTACTS

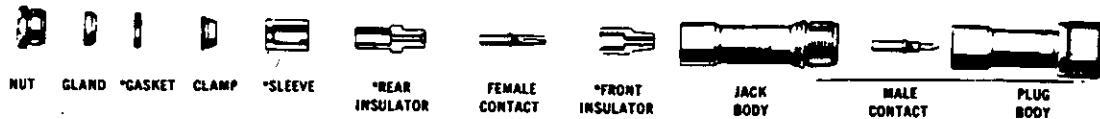

	<p>Cut end of cable even. Strip off vinyl jacket 1-5/8" as shown.</p>
	<p>Comb out braid as shown. Cut off dielectric 29/32" from end of jacket.</p>
	<p>Taper braid wires forward and slide nut and gland onto jacket. Make certain knife edge of gland is toward end of cable. Then slide gasket onto jacket with 'V' groove toward gland. Clamp is now pushed over braid so that internal shoulder butts flush against cable jacket. A non-contaminating type of plastic tape may be used to hold the braided wires in the tapered position while parts are placed in position over the jacket.</p>
	<p>Fold braid back over clamp and trim. Tin exposed center conductor using minimum amount of heat. Slide sleeve and rear insulator over cable dielectric. Soft solder contact to center conductor. Rear insulator must seat against cable dielectric and contact shoulder must be flush with insulator face as shown. Coat cable dielectric and insulator mating surfaces with Silicone Compound to achieve 5KV peak rating under operating conditions. For jacks only, install front insulator (dotted outline).</p>
	<p>Slide prepared cable termination carefully into body. Be sure knife edge of gland remains in groove of gasket. Tighten nut with wrench holding body stationary. Gasket should be cut in half during tightening.</p>

MIL-HDBK-216
SECTION 3A
18 May 1965

ASSEMBLY INSTRUCTIONS FOR SERIES LC CONNECTORS

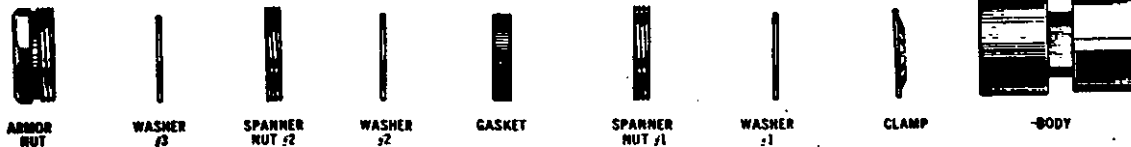

	<p>Slide armor nut and washer # 3 over armor. Cut off armor 2-3/4" from end. Cut vinyl jacket 2-3/8" from end. Cut copper braid 2-1/8" from end.</p>
	<p>Push armor back approx. 12-3/8" from end. Slide spanner nut # 2, washer # 2, gasket and spanner nut # 1 over vinyl jacket. Carefully slide washer # 1 over copper braid as shown.</p>
	<p>Fan out copper braid radially, trim any loose or ragged edges with cutters or scissors. All metal particles must be cleaned off dielectric. Slide clamp over dielectric (prongs toward connector as shown) and press it against copper braid. Apply silicone compound to clamp surfaces.</p>
	<p>Insert formed end of cable into plug body. With a spanner wrench screw spanner nut # 1 very tight against washer # 1. This locks the copper braid and forces the clamp into the dielectric. Sufficient pressure should be applied to insure clamp is pressed into dielectric and is flattened to provide good contact with braid. Apply a thin film of silicone compound to the surfaces of the gasket for better sealing. Slide washer # 2 against gasket. Screw spanner nut # 2 tight against washer # 2.</p>
	<p>Turn up armor 1/4" (radially). Push armor into body by squeezing bulge. Push washer # 3 against armor. Screw up armor nut tight against washer # 3. With sharp knife cut dielectric flush with forward edge of coupling ring. Pry off cut dielectric. Cut off center conductor 1/2" from forward edge of coupling ring. File end of center conductor round and clean off all filings. Apply small amount of silicone compound to end of dielectric just before mating this plug.</p> <p>NOTE: When using RG-17/U cable disregard all instructions pertaining to armor.</p>

Illustrations courtesy of Amphenol Electronics Corp.

MIL-HDBK-216
SECTION 3A
18 May 1965

ASSEMBLY INSTRUCTIONS FOR SERIES LN CONNECTORS

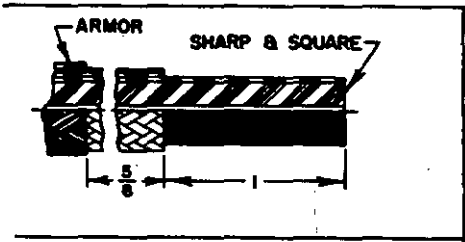
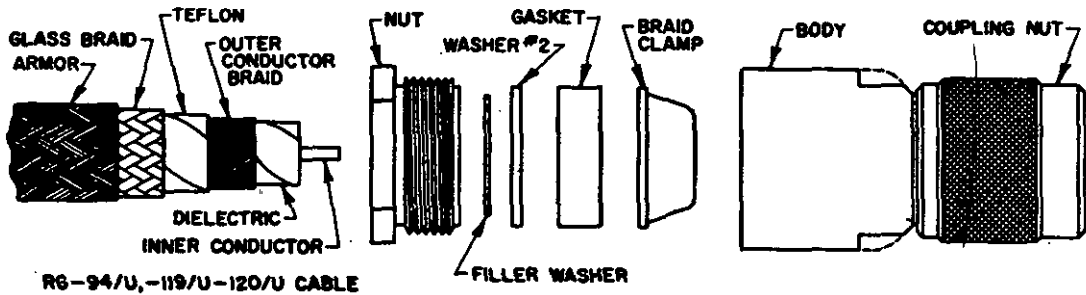

Cut end of cable even. Cut off armor 1-5/8" from end. Cut fiberglass braid jacket, and teflon tape 1" from end. Care should be taken to avoid nicking copper braid.

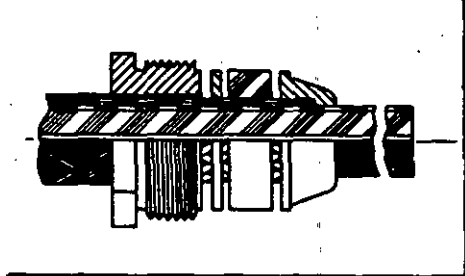

Slide nut filler washer over armor. (Ream nut to .540" if too tight). Fan back armor 1/8". Slide washer #2 and gasket over jacket. Slide clamp over braid. Shoulder of clamp should be seated against braid and tape. (Apply a coat of Dow-Corning compound #4* to gasket).

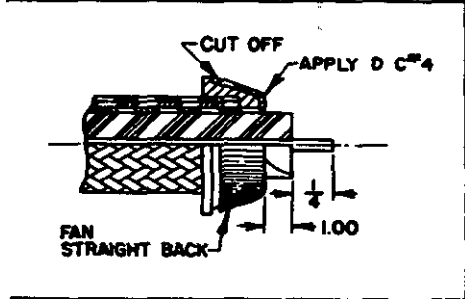

Comb out both braids and fan back over tapered shoulder of clamp. Cut off excess braid just short of external flange of clamp. Cut off dielectric .100" from point where braids bend back over clamp. Care should be taken to avoid nicking center conductor. Apply Dow-Corning compound #4* as indicated. Cut inner conductor off 1/4" from end of dielectric. Tin center conductor using minimum heat. Soft solder contact to center conductor. Contact must be tight against cable dielectric. Wipe dielectric and contact clean.

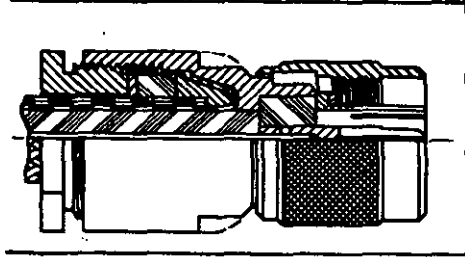

Carefully slide body with coupling nut attached over end of cable so that contact enters hole in insulator. Face of cable dielectric must fit flush against insulator. Slide gasket, both washers and nut against braid clamp. Holding body stationary, tighten nut securely.

MIL-HDBK-216
SECTION 3A
18 May 1965

ASSEMBLY INSTRUCTIONS FOR SERIES LN CONNECTORS (Cont'd)

NOTES.

1. When jack and plug are assembled together completing the installation, varnish liberally with vinyl resin varnish* to a point 4" from each end of the entire assembly. After drying, cover the varnished area with several layers of vinyl tape*. Where exposure is especially severe, this assembly should be protected from water and sunlight by a junction box or the metal cover.
2. Connection to RG-10/U cable can be made by connecting described assembly with UG-108/U adapter to type "N" plug UG-21/U or RG-10/U cable.
3. Connection to RG-18/U cable can be made by connecting RG-94/U with UG-531/U jack with UG-213/U adapter to UG-167/U plug on RG-18/U cable.
4. When cable without armor is used, disregard all instructions pertaining to armor.

*Materials to be used are as follows:

Dow-Corning Compound #4: (Dielectric Compound - MIL-I-8660)

Stock numbers are: ESO Stock No. N16-C-12863-500.

Aviation supply Stock No.: R52-C-3109-110 for an 8 oz. cartridge and
R52-C-3107-125 for a 10 lb. can.

Vinyl Resin Varnish:

20% solution of vinyl chloride-acetate, maleic acid, modified copolymer (Bakelite Corp. VM-CH) in a 50-50 mixture of Methyl-Ethyl-Ketone and Toluene (Toluol). Methyl-Ethyl-Ketone Fed. Std. Stock No. 51-K-16150-50 (5 gal. can).

Vinyl Tape:

Federal Standard Stock Catalog No. 17-T-1745-60 for a 3/4" roll should be ordered from GSSO, Philadelphia, (A commercial substitute Minnesota Mining Co. #22 plastic vinyl adhesive tape may be ordered from the electronics supply system under Stock No. N16-T-448.

MIL-HDBK-216
SECTION 3A
18 May 1965

ASSEMBLY INSTRUCTIONS FOR SERIES LT CONNECTORS

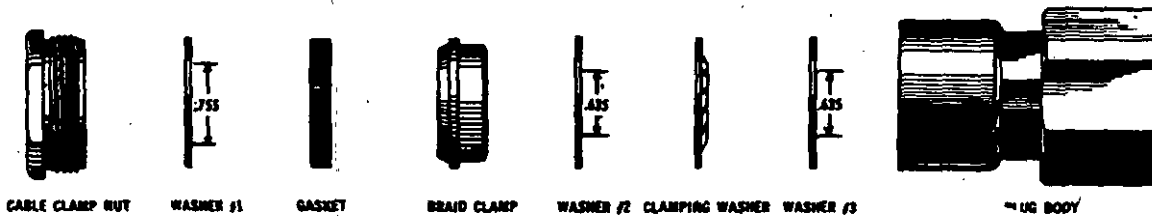

CABLE CLAMP NUT

WASHER #1

GASKET

BRAID CLAMP

WASHER #2

CLAMPING WASHER

WASHER #3

PLUG BODY

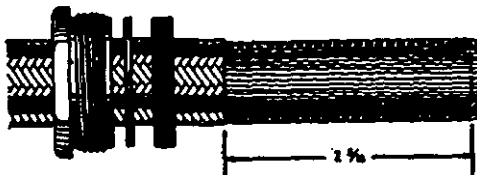

Slide cable clamp nut, washer #1 and gasket over cable jacket. Cut off jacket and Teflon tape sharp and square to dimension shown. Do not nick braid. Comb out braid smoothly against dielectric, as shown.

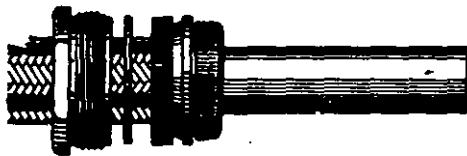

Slide on braid clamp so that it butts snugly against end of cable jacket. Form braid back smoothly over braid clamp and trim off excess braid, as shown.



Slide washer #2, clamping washer (with prongs toward trimmed end of cable, as shown) and washer #3 over dielectric. Butt these parts against the braid.

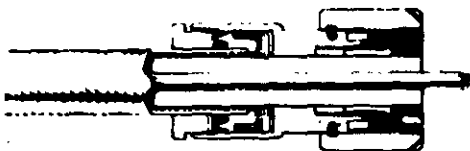

Slide plug body over this assembly and screw on tightly with wrench. Hold cable and cable clamp nut stationary during this operation. Sufficient pressure should be applied to insure that clamping washer is pressed into dielectric and is flattened. Cable dielectric will now protrude past end of plug coupling nut. Cut the dielectric off flush and square with the forward edge of the coupling nut, as shown. Do not nick the center conductor. Check the extension of the center conductor - if it is greater than 1/2", cut off excess. Round off end of center conductor with a file, being careful not to let chips or filings fall into the end of the conductor.

Illustrations courtesy of Amphenol Electronics Corp.

MIL-HDBK-216
SECTION 3A
18 May 1965

ASSEMBLY INSTRUCTIONS FOR SERIES N CONNECTORS



*REPLACE WASHER AND GASKET IN:
UG-21C-U
UG-22C-U
UG-23C-U
UG-1600-U

	<p>Remove 9/16" of vinyl jacket. When using double shielded cable, remove 5/8".</p>
	<p>Comb out copper braid as shown. Cut off dielectric 7/32" from end. Tin center conductor.</p>
	<p>Taper braid as shown. Slide nut, washer and gasket over vinyl jacket. Slide clamp over braid with internal shoulder of clamp flush against end of vinyl jacket. When assembling connectors with gland, be sure knife-edge is toward end of cable and groove in gasket is toward the gland. A non-contaminating type of plastic tape may be used to hold the braided wires in the tapered position while parts are placed in position over the jacket.</p>
	<p>Smooth braid back over clamp and trim. Soft solder contact to center conductor. Avoid use of excessive heat and solder. See that end of dielectric is clean. Contact must be flush against dielectric. Outside of contact must be free of solder.</p>
	<p>Slide body into place carefully so that contact enters hole in insulator. Face of dielectric must be flush against insulator. Slide completed assembly into body by pushing nut. When nut is in place, tighten with wrenches. In connectors with gland, knife-edge should cut gasket in half by tightening sufficiently.</p>

MIL-HDBK-216
SECTION 3A
18 May 1965

ASSEMBLY INSTRUCTIONS FOR IMPROVED SERIES N CONNECTORS



	<p>Place nut and gasket, with "V" groove toward clamp, over cable and cut off jacket $9/32$" from end.</p>
	<p>Comb out braid and fold out. Cut off cable dielectric flush $1/8$" from end of jacket.</p>
	<p>Pull braid wires forward and taper toward center conductor. Place clamp over braid and push back against cable jacket. A non-contaminating type of plastic tape may be used to hold the braided wires in the tapered position while parts are placed in position over the jacket.</p>
	<p>Fold back braid wires as shown, trim to proper length and form over clamp as shown. Solder contact to center conductor.</p>
	<p>Insert cable and parts into connector body. Make sure sharp edge of clamp seats properly in gasket. Tighten nut.</p>

MIL-HDBK-216.
SECTION 3A
18 May 1965

ASSEMBLY INSTRUCTIONS FOR SERIES N CONNECTORS WITH CAPTIVATED CONTACTS

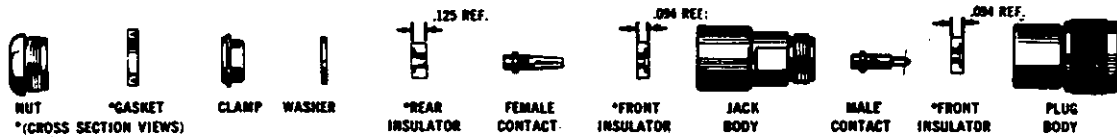

	<p>Cut end of cable even. Place nut and gasket with "V" groove toward clamp, over cable and cut off jacket $23/64$" from end.</p>
	<p>Comb out braid as shown. Cut off cable dielectric $1/8$" from end of jacket.</p>
	<p>Pull braid wires forward and taper toward center conductor. Place clamp over braid and push back against cable jacket. A non-contaminating type of plastic tape may be used to hold the braided wires in the tapered position while parts are placed in position over the jacket.</p>
	<p>Fold back braid wires as shown, trim to proper length and form over clamp as shown. Tin exposed center conductor using minimum amount of heat. Slide on washer, rear insulator and contact. Contact shoulder, insulator, and cable core must butt as shown. Solder contact to center conductor.</p>
	<p>Slide front insulator over contact. Be sure to place counter bore end of insulator toward mating end of contact.</p>
	<p>Insert prepared cable termination into connector body. Make sure sharp edge of clamp seats properly in gasket. Tighten nut, holding body stationary.</p>

MIL-HDBK-216
SECTION 3A
18 May 1965

ASSEMBLY INSTRUCTIONS FOR CERAMIC INSERT PULSE CONNECTORS

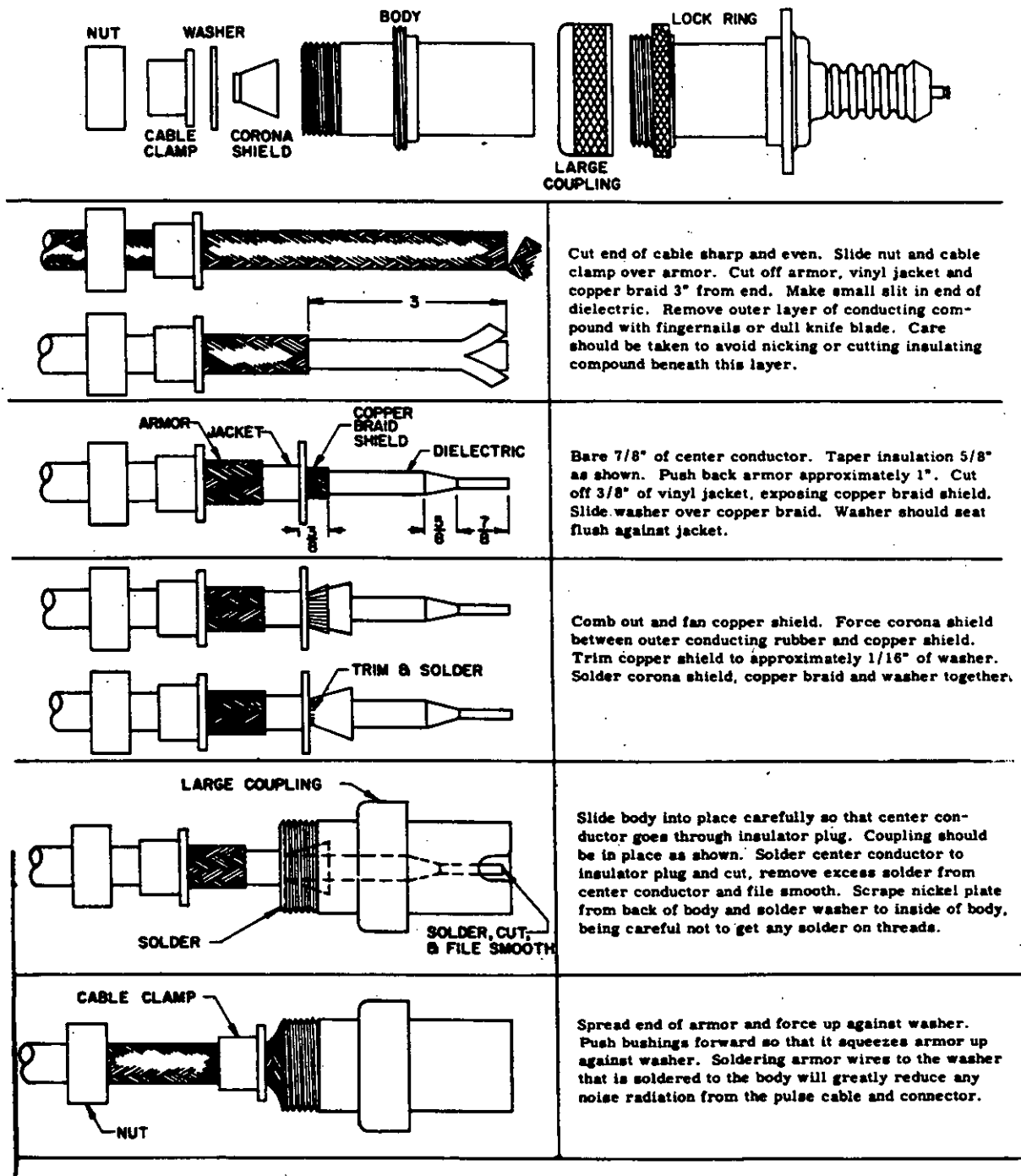

MIL-HDBK-216
SECTION 3A
18 May 1965

CERAMIC INSERT PULSE CONNECTORS (Cont'd)

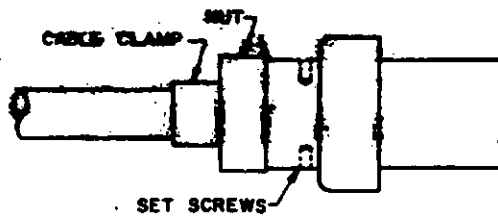

Pull nut over bushing and screw tightly to body. Remove set screws and fill with Dow Corning #4 by forcing it into the sleeve from the bottom hole by means of a gun until the compound starts to ooze out the top hole. It is important that the Dow Corning compound completely fill the body and exclude all air. Replace set screws.

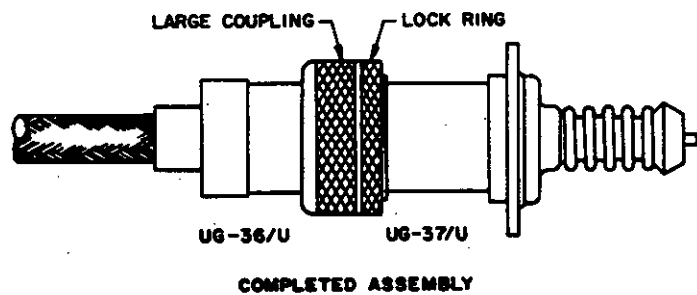

MIL-HDBK-216
SECTION 3A
18 May 1965

ASSEMBLY INSTRUCTIONS FOR RUBBER INSERT PULSE CONNECTORS

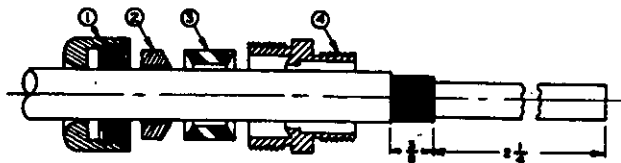
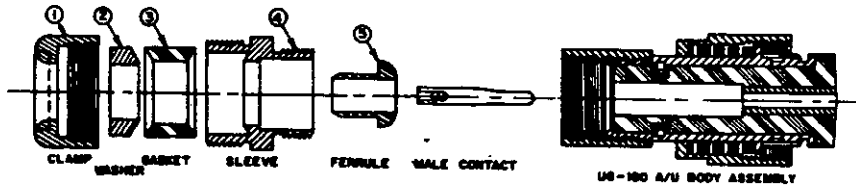

Slide parts 1, 2, 3 and 4 over armor. Push armor back to allow jacket to be cut. Cut jacket off $2\text{-}1/4"$ from end. Care should be taken to avoid nicking or cutting copper braid. Trim back braid or braids $3/8"$ from cable jacket. Care should be taken to avoid nicking or cutting cable core.

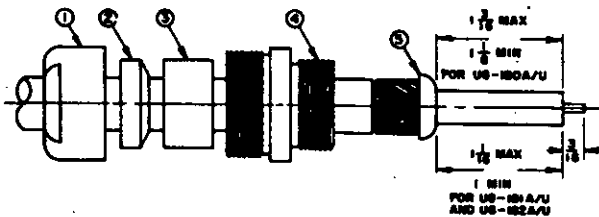

Fold back outer braid. Push part 5 over cable core and under inner braid. Solder inner braid wire to part 5 all around circumference making sure solder flows thru to hold all braids. Bring forward outer braid and solder on top of inner braid. Bring forward armor to shoulder of part 5. Clean and tin armor and solder over the braid wires. Grasp cable in left hand and part 5 in right hand and give assembly several quick pulls to make sure that any slack in braid wires has been removed. Cut cable core to dimensions shown depending on what connector is being used. Cut center conductor $3/16"$ from cable core and tin.

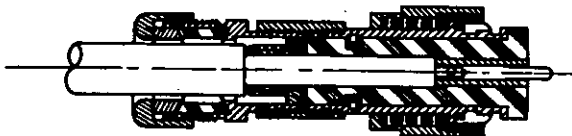

Solder contact to conductor and remove excess solder. Contact must be tight against cable dielectric. Apply a thin layer of Dow-Corning #4 compound to cable dielectric. Push cable dielectric into body assembly as far as it will go. If trouble is encountered in making the contact enter the hole in the rubber insert, a guide may be prepared from a $3"$ length of #14 solid wire with a female contact soldered to one end. For inserting a female contact, a similar guide with a male contact pin soldered to one end may be used. Wipe off excess Dow-Corning compound which may be squeezed out on the front or back end. Hold body securely with a wrench and insert part 4 and tighten against part 5. Part 4 should be tightened as much as it will go. Insert part 3 into part 4; follow with part 2 and tighten part 1 on part 4. This should be tightened sufficiently to deform the gasket part 3 around the cable and hold it securely.

MIL-HDBK-216
SECTION 3A
18 May 1965

ASSEMBLY INSTRUCTIONS FOR RUBBER INSERT PULSE CONNECTORS (Cont'd)

NOTES.

1. When cable without armor is used, disregard all instructions pertaining to armor.
2. The rubber cables RG-25A/U, RG-26A/U, RG-62A/U, RG-77/U and RG-78/U have a thin layer of red rubber over the cable core. This is not removed from the cable core. The older rubber cables RG-25/U, RG-26/U and RG-62/U have a thin layer of black conducting rubber over the cable dielectric and this must be removed from the core 1/16" from part 5 when using these connectors. This operation must be performed very carefully with a sharp knife. There must be no small cuts or nicks in the cable dielectric after removal of the black conducting rubber layer.

MIL-HDBK-216
SECTION 3A
18 May 1965

ASSEMBLY INSTRUCTIONS FOR RG-1372/U TO RG-189/U CABLE

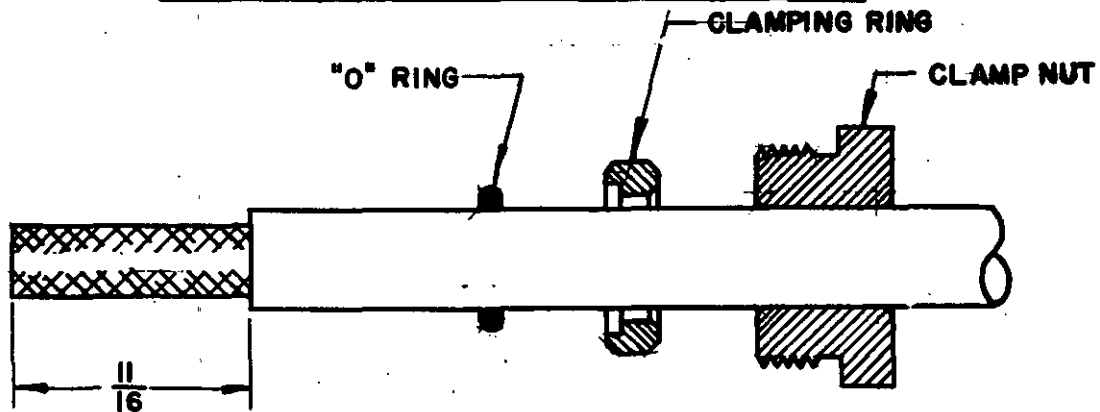

1. Place the clamp nut, clamping ring and cable sealing O-ring on the cable.
2. Cut the jacket of the cable square and back far enough so that the correct length of center conductor will protrude beyond the face of the cable core when the cable preparation is complete.

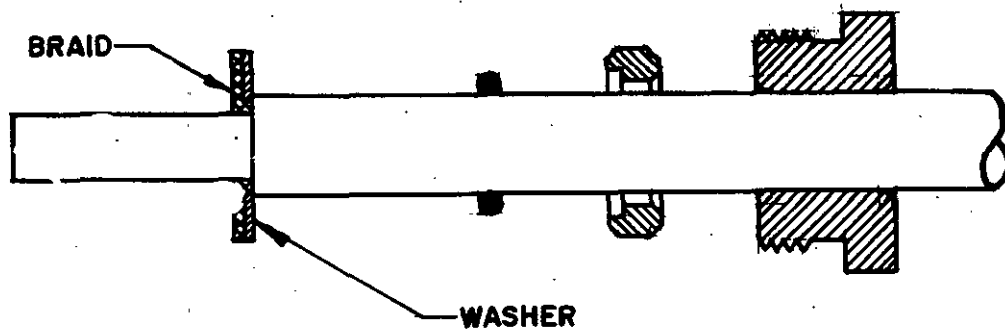

3. Place the clamping washer over the braid until it butts against the jacket.
4. Fold the braid against the washer and cut it so that there are no strands extending beyond the outer diameter of the washer.

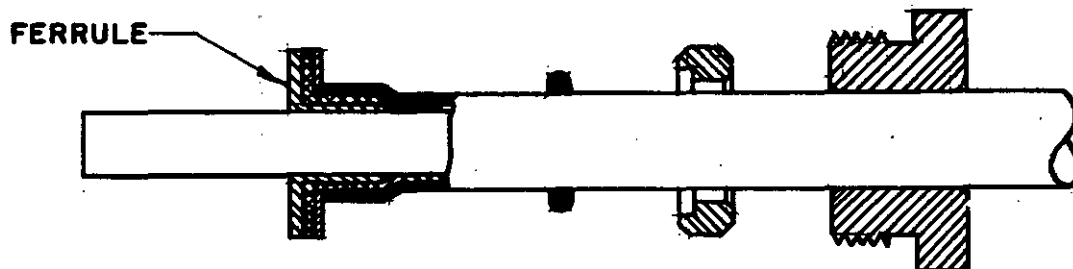

5. Install the ferrule over the cable core until the braid is contained between the washer and the flange of the ferrule.

MIL-HDBK-216
SECTION 3A
18 May 1965

ASSEMBLY INSTRUCTIONS FOR RF-1372/U TO RG-189/U CABLE - Cont'd

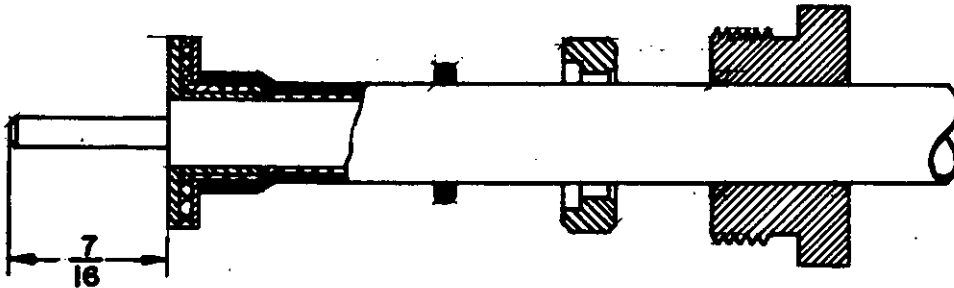

6. Cut the cable core flush with the flange of the ferrule using a hot cutting tool for best results.
7. Cut the center conductor if necessary so that it extends the correct length. Chamfer the end of the center conductor with a file.

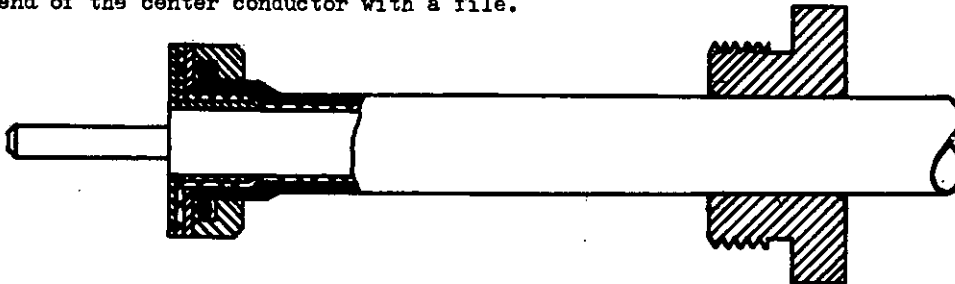

8. Insert the cable sealing O-ring in the clamping ring groove. Apply some O-ring lubricant on the jacket and force the clamping ring against the clamping washer.

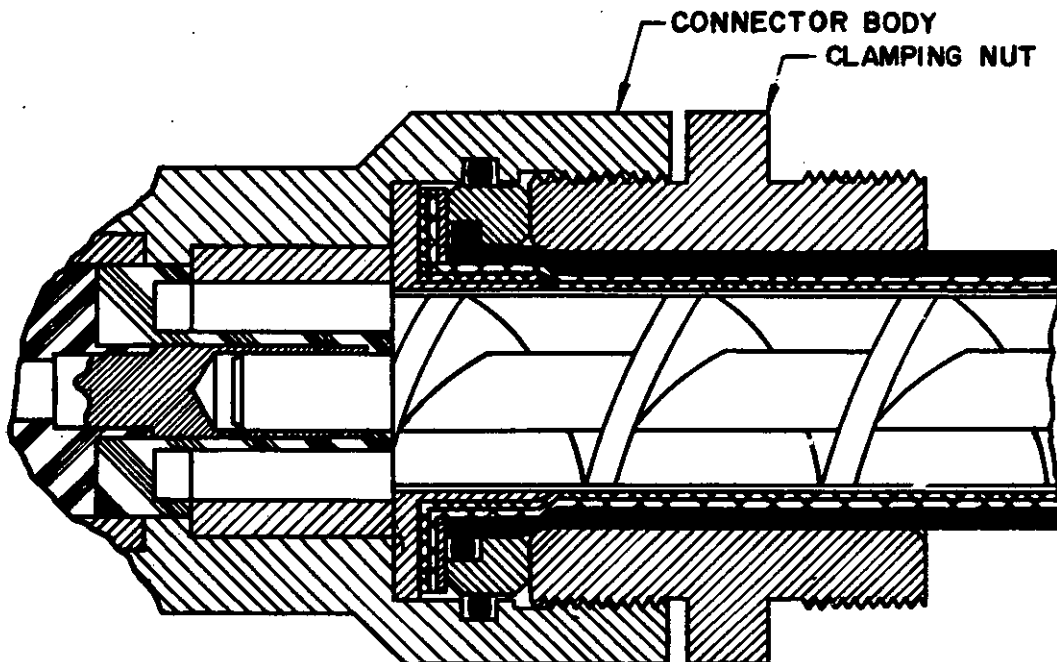

9. Insert the prepared cable into the connector body as far as possible. Finally, tighten the clamping nut with a wrench.

MIL-HDBK-216
SECTION 3A
18 May 1965

ASSEMBLY INSTRUCTIONS FOR SERIES QL AND QM CONNECTORS

A. Cable Preparation

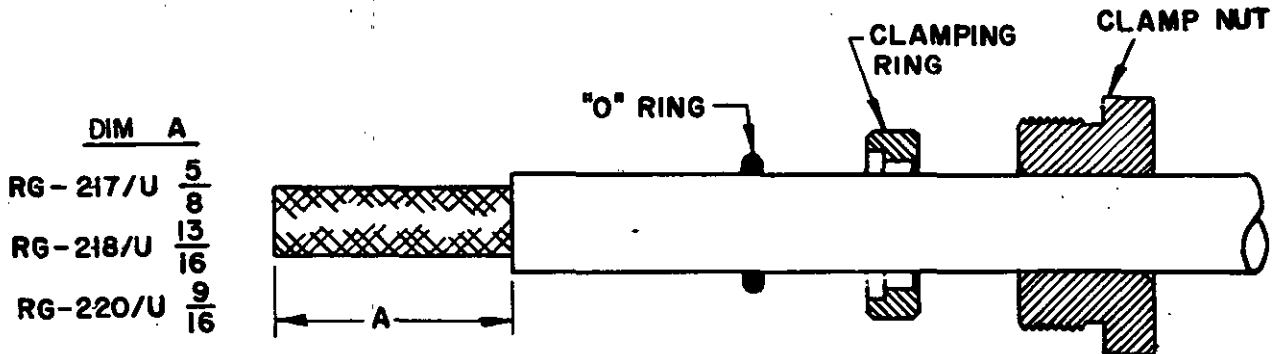

1. Place the clamp nut, clamping ring and cable sealing O-ring on the cable.
2. Cut the jacket of the cable square and back far enough so that the correct length of center conductor will protrude beyond the face of the cable core when the cable preparation is complete.

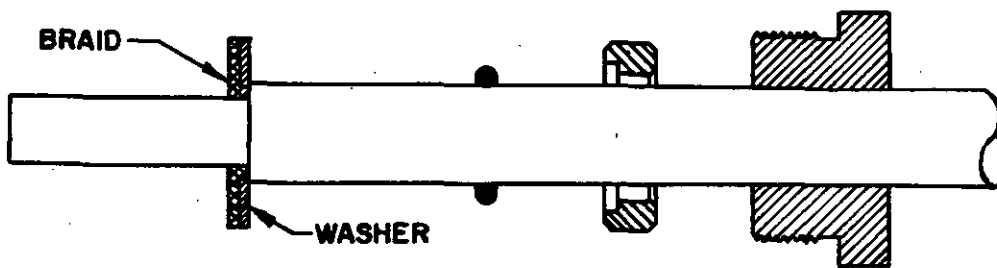

3. Place the clamping washer over the braid until it butts against the jacket.
4. Fold the braid against the washer and cut it so that there are no strands extending beyond the outer diameter of the washer.

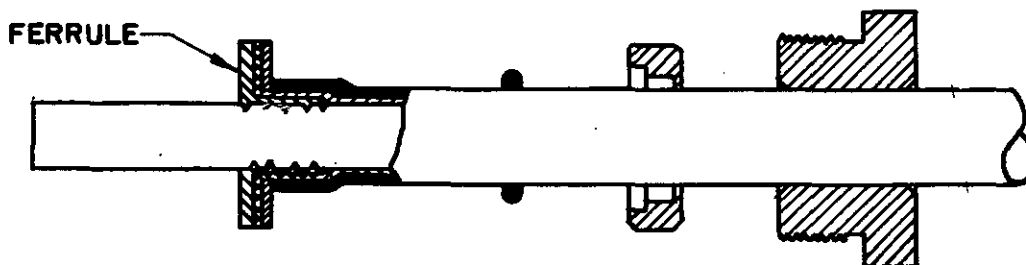

5. Install the ferrule over the cable core until the braid is contained between the washer and the flange of the ferrule.

MIL-HDBK-216
SECTION 3A
18 May 1965

ASSEMBLY INSTRUCTIONS FOR SERIES QL AND QM CONNECTORS - Cont'd

	<u>DIM B</u>
RG-217/U	$\frac{7}{16}$
RG-218/U	$\frac{9}{16}$
RG-220/U	$\frac{7}{16}$

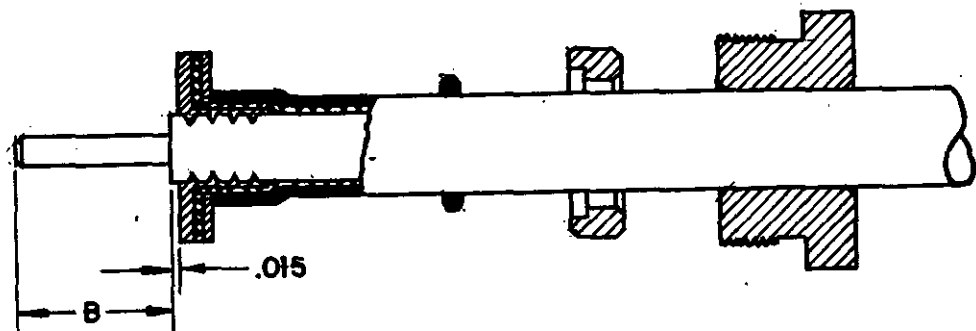

- Cut the cable core flush with the flange of the ferrule. The ferrule should then be threaded further onto the cable until the core extends beyond the ferrule flange approximately $\frac{1}{64}$ ".
- Cut the center conductor if necessary so that it extends the correct length. Chamfer the end of the center conductor with a file.

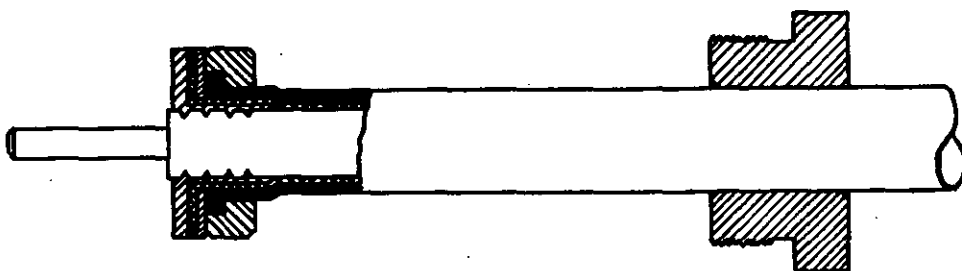

- Insert the cable sealing O-ring in the clamping ring groove. Apply some O-ring lubricant on the jacket and force the clamping ring against the clamping washer.

MIL-HDBK-216
SECTION 3A
18 May 1965

ASSEMBLY INSTRUCTIONS FOR SERIES QL AND QM CONNECTORS - Cont'd

B. Cable to Connector Assembly
RG-217/U and RG-218/U Cable

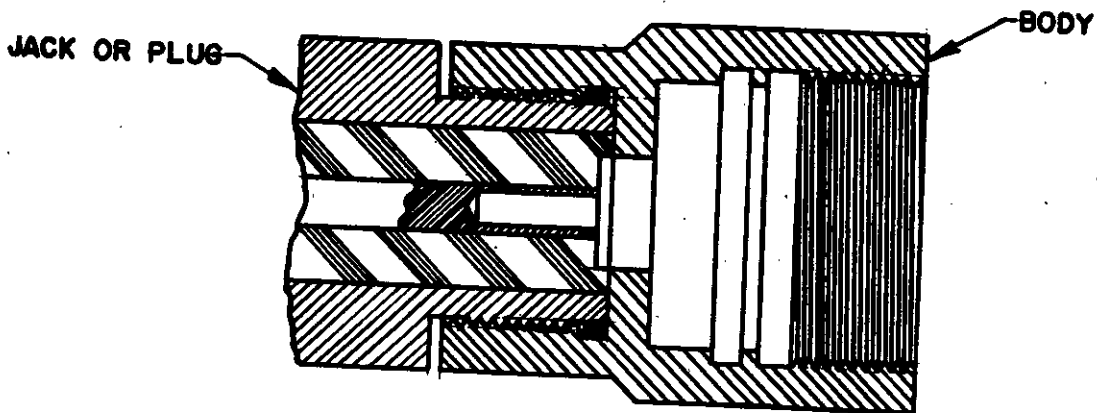

1. Assemble the accessory body to the jack or plug and tighten with a wrench.

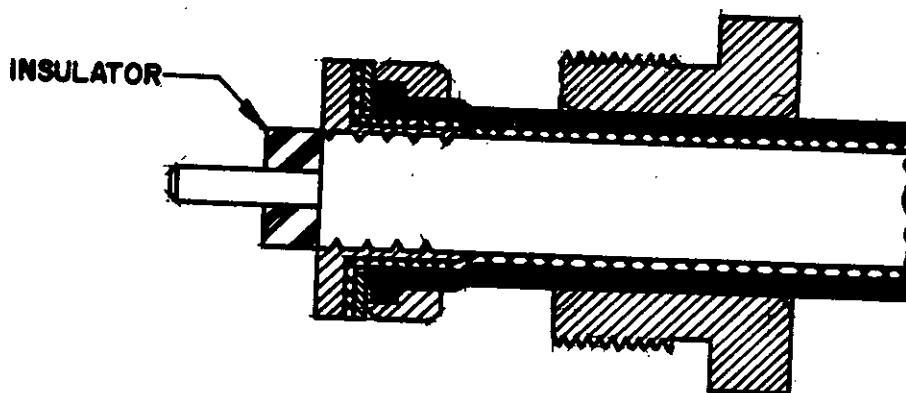

2. Install the small teflon insulator on the center conductor of the cable and push it back against the cable core.

MIL-HDBK-216
SECTION 3A
18 May 1965

ASSEMBLY INSTRUCTIONS FOR SERIES QL AND QM CONNECTORS - Cont'd

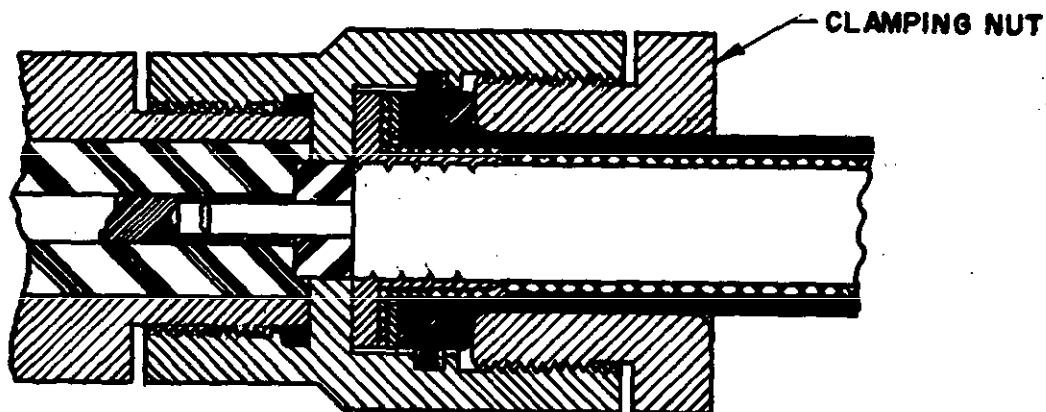

3. Insert the prepared cable into the connector as far as possible. Finally, tighten the clamping nut with a wrench.

C. Cable to Connector Assembly
RG-220/U Cable

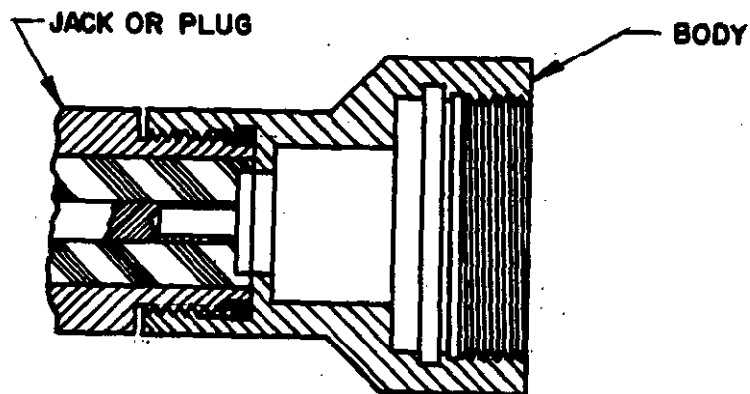

1. Assemble the accessory body to the jack or plug and tighten with a wrench.

MIL-HDBK-216
SECTION 3A
18 May 1965

ASSEMBLY INSTRUCTIONS FOR SERIES QL AND QM CONNECTORS - Cont'd

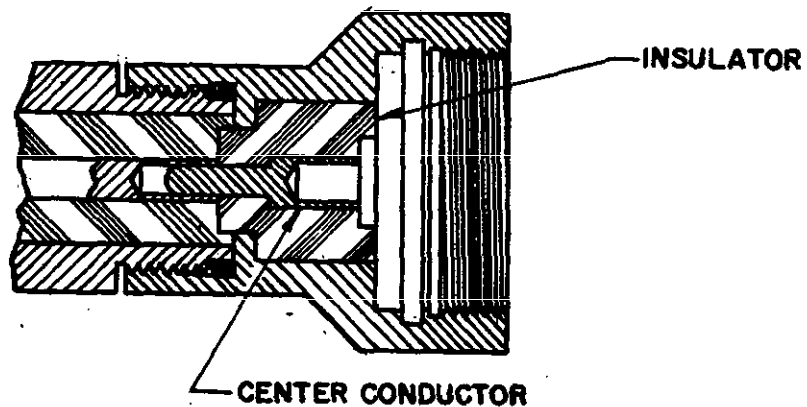

2. Install the large diameter insulator and center conductor in the accessory body.

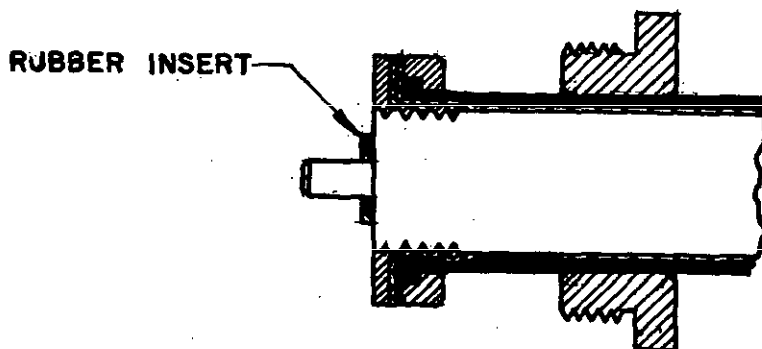

3. Place the rubber insert on the center conductor of the cable and push it back against the cable core.

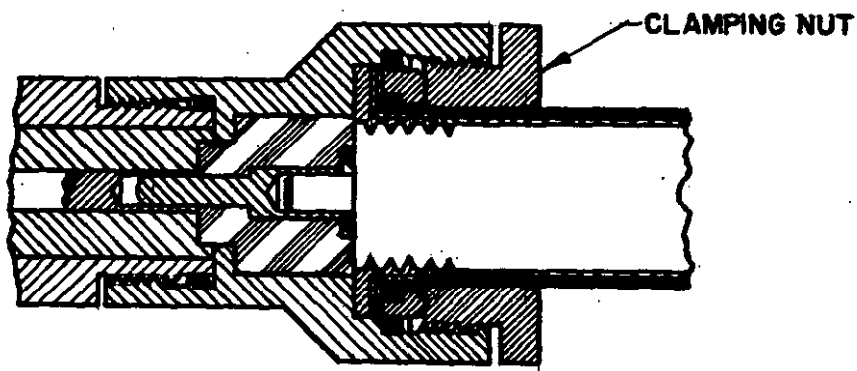

4. Insert the prepared cable into the connector as far as possible. Finally, tighten the clamping nut with a wrench.

MIL-HDBK-216
SECTION 3A
18 May 1965

ASSEMBLY INSTRUCTIONS FOR SERIES QL AND QM CONNECTORS - Cont'd

D. Armored Cable

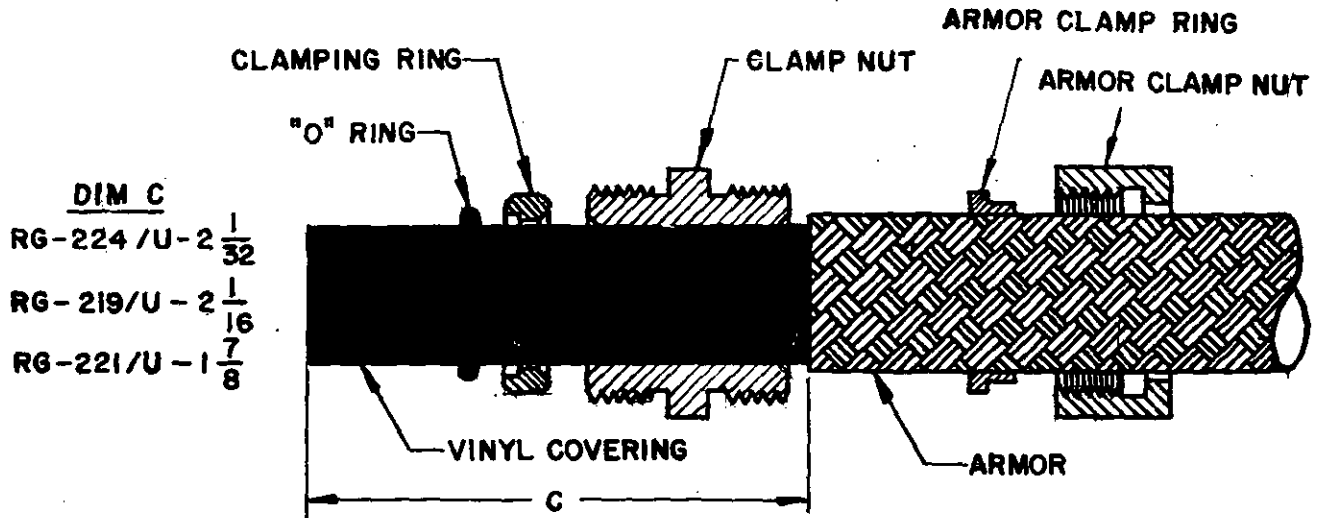

1. Cut armor braid back from leading edge of the cable to dimension as shown.
2. Place armor clamp nut and armor clamping ring on the cable over the armor braid.
3. Place the clamp nut, clamping ring and cable sealing O-ring over the vinyl covering of the cable.
4. Perform steps 2 through 8 in Section A of Assembly Instructions.

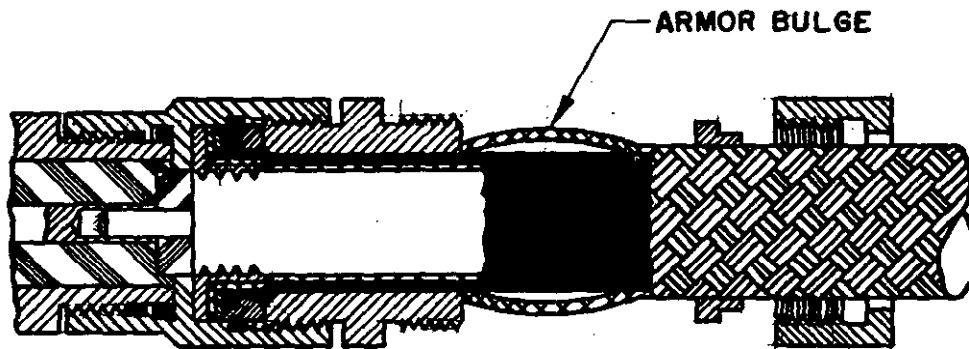

5. For RG-224/U and RG-219/U cable to connector assembly, perform steps 1 through 3 in Section B of Assembly Instructions, using the cable accessory arrangement shown above; form a bulge in the armor braid to manipulate accessories into place.

MIL-HDBK-216
SECTION 3A
18 May 1965

ASSEMBLY INSTRUCTIONS FOR SERIES QL AND QM CONNECTORS - Cont'd

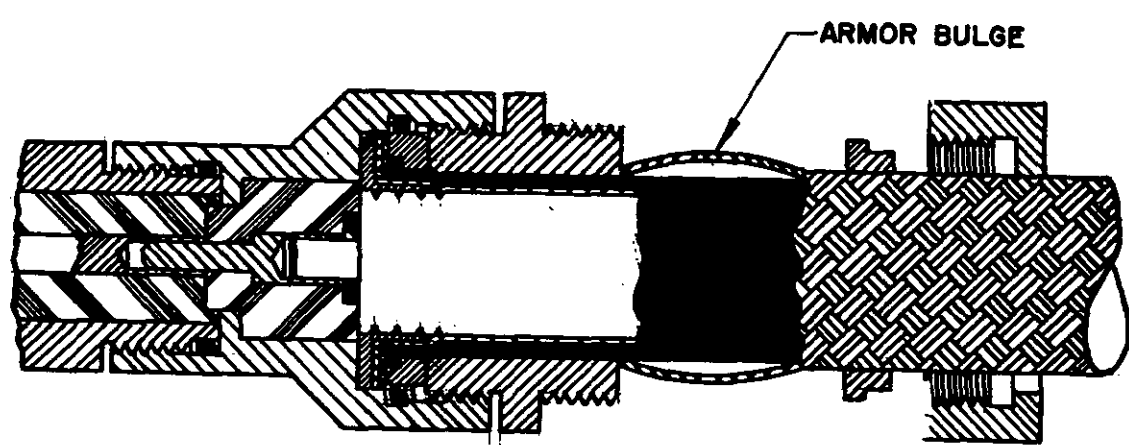

6. For RG-221/U cable to connector assembly, perform steps 1 through 4 in Section C of Assembly Instructions using the cable accessory arrangement shown above; form a bulge in the armor braid to manipulate accessories into place.

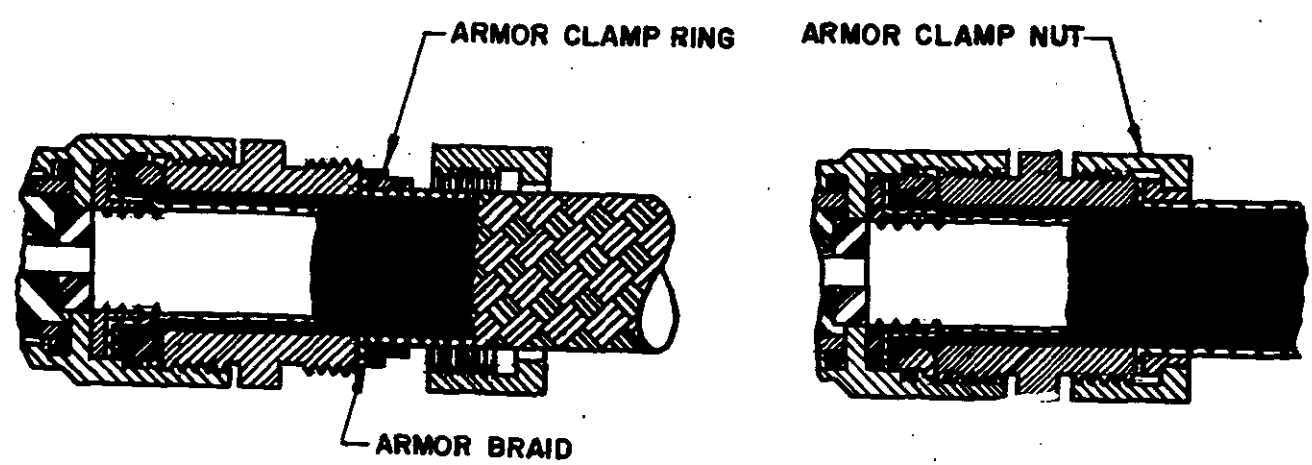

7. Fold armor braid against the back edge of the clamp nut and trim even with the clamp nut threads.
8. Slide the armor clamping ring against the clamp nut, containing the armor braid securely between the two.
9. Finally, screw on the armor clamp nut tightly with a wrench.

MIL-HDBK-216
SECTION 3A
18 May 1965

ASSEMBLY INSTRUCTIONS FOR SERIES SM CONNECTORS

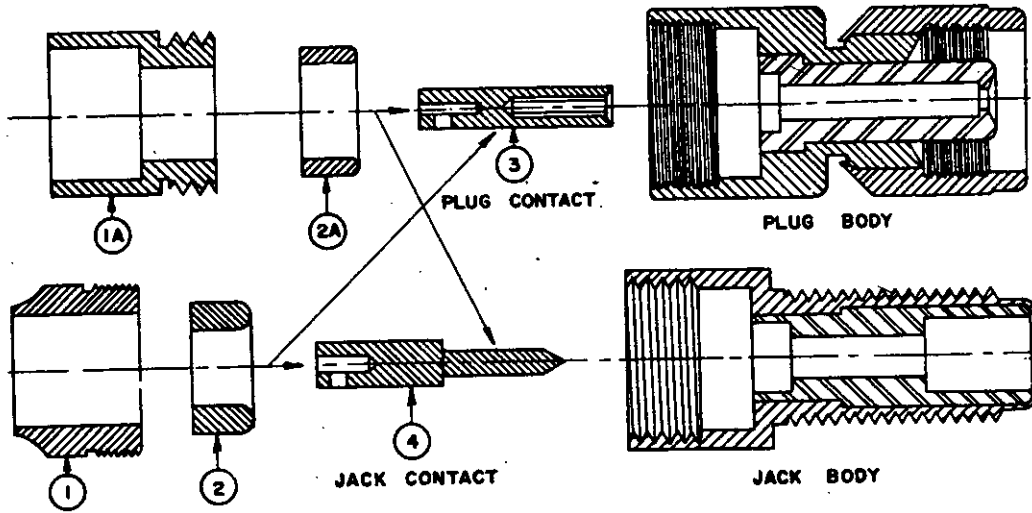

<p>1</p> <p>.410 FOR RG-59 A/U & RG-62 A/U .230 FOR ALL OTHER CABLES.</p>	<p>Cut jacket as shown. Slide part 1 over cable. (part 1A, used for cables RG-59A/U and RG-62A/U, will extend only partly over the jacket.)</p>
<p>1</p> <p>2</p> <p>ROUNDED EDGE</p>	<p>Comb out braid wires and taper inward. Slide part 2 over braid.</p>
<p>1</p> <p>2</p> <p>0 FOR RG-62A/U .049 FOR ALL OTHER CABLES.</p>	<p>Trim excess length of braid wires. Fan back over part 2. Cut cable dielectric as shown.</p>

MIL-HDBK-216
SECTION 3A
18 May 1965

ASSEMBLY INSTRUCTIONS FOR SERIES SM CONNECTORS (Cont'd)

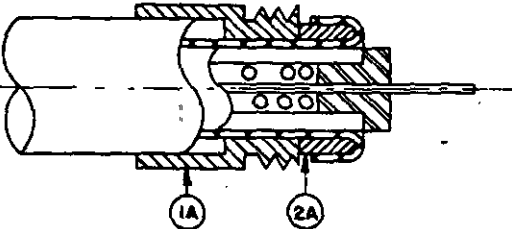
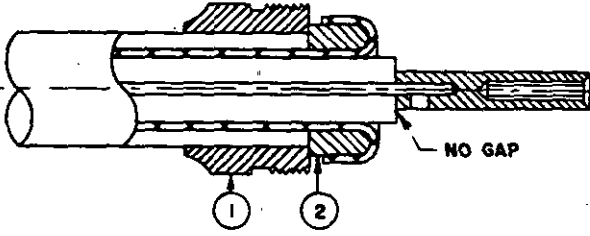
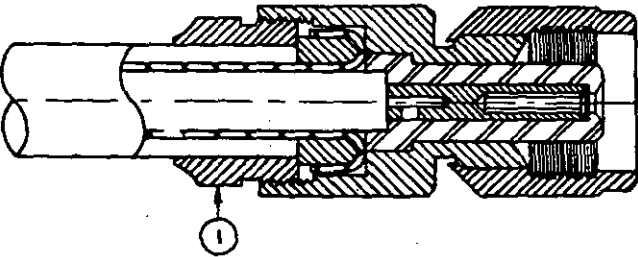
	<p>Slide insulator bushing over conductor and into hollow core of cable dielectric. (For RG-62A/U only)</p>
	<p>Tin conductor. Soft solder contact to conductor thru hole in same. Remove excess solder.</p>
	<p>Slide cable into connector body, and tighten part 1 securely as shown. (Part 1 or 1A may be crimped around cable to provide additional holding power.)</p>

NOTE: The plug insulator may be removed from body and slipped over contact and cable dielectric prior to final assembly.

MIL-HDBK-216
SECTION 3A
18 May 1965

ASSEMBLY INSTRUCTIONS FOR SERIES UHF CONNECTORS



COUPLING RING



PLUG SUB-ASSEMBLY

ASSEMBLY OF CABLES TO PL-259 (NT49190) PLUG

	<p>Cut end of cable even. Remove vinyl jacket 1-1/8".</p>
	<p>Bare 5/8" of center conductor. Trim braided shield. Slide coupling ring on cable. Tin exposed center conductor and braid.</p>
	<p>Screw the plug sub-assembly on cable. Solder assembly to braid through solder holes. Use enough heat to create bond of braid to shell. Solder center conductor to contact.</p>
	<p>For final assembly, screw coupling ring on plug sub-assembly.</p>

ASSEMBLY OF CABLES TO PL-259 PLUG USING ADAPTER UG-176/U OR UG-175/U

	<p>Cut end of cable even. Remove vinyl jacket 3/4". Slide coupling ring and adapter on cable.</p>
	<p>Fan braid slightly and fold back as shown.</p>
	<p>Position adapter to dimension shown. Press braid down over body of adapter and trim to 3/8". Bare 5/8" of conductor. Tin exposed center conductor.</p>
	<p>Screw plug sub-assembly on adapter. Solder braid to shell through solder holes. Use enough heat to create bond of braid to shell. Solder conductor to contact.</p>
	<p>For final assembly, screw coupling ring on plug sub-assembly.</p>

Illustrations courtesy of Amphenol Electronics Corp.

MIL-HDBK-216
SECTION 3A
18 May 1965

ASSEMBLY INSTRUCTIONS FOR UHF CONNECTORS (Cont'd)

ASSEMBLY OF CABLES TO PL-259A (NT49195) PLUG



BACK SHELL



COUPLING RING



PLUG SUB-ASSEMBLY

	<p>Cut end of cable even. Remove vinyl jacket 1-1/8".</p>
	<p>Bare 5/8" of center conductor. Tin exposed conductor and braid. Slide back shell and coupling ring on cable.</p>
	<p>Screw the plug sub-assembly on cable. Solder this assembly to braid through solder holes. Solder center conductor to contact. Do not use excessive heat.</p>
	<p>For final assembly, slide coupling ring over plug sub-assembly, then position back shell with sufficient clearance to permit free rotation of coupling out and tighten set screw.</p>

ASSEMBLY OF TWINAX CABLES TO UG-1060/U PLUG

	<p>Cut end of cable even. Remove vinyl jacket 1-1/4.</p>
	<p>Bare 5/8" of conductors. Tin exposed conductors and braid.</p>
	<p>Slide coupling ring on cable. Screw back shell on cable. Solder hole should align with conductors as shown.</p>
	<p>Assemble front shell to back shell. Solder holes in both front and back shells should align. Solder braid to shells through solder holes. Solder conductors to contacts. Do not use excessive heat.</p>
	<p>For final assembly screw coupling ring on back shell.</p>

Illustrations courtesy of Amphenol Electronics Corp.

MIL-HDBK-216
SECTION 3A
18 May 1965

ASSEMBLY INSTRUCTIONS FOR SERIES UHF HOODS

UG-177/U



UG-106/U



UG-372/U



	Cut end of cable even. Remove vinyl jacket to appropriate dimension. Tin exposed braid.	UG-177/U 3/4	UG-106/U 5/8	UG-372/U 3/4
	Remove braid and dielectric to expose center conductor.	5/16	5/16	5/16
	Remove braid to expose dielectric to approximate dimension. Tin center conductor. Soldering and assembly depends on the hood used, as illustrated below.	3/8	3/16	3/8
	Slide hood over braid.* Solder conductor to contact. Slide hood flush against receptacle and tack-solder hood flange to receptacle flange. Solder hood to braid. Tape this junction or use vinyl tubing. *When using RG-55/U, outer braid is brought over neck section of hood and terminated and soldered at beginning of taper after hood is soldered to receptacle.	UG-177/U	—	—
	Slide hood over braid. Bring receptacle flush against hood. Solder conductor to contact and hood to braid. Tape this junction or use vinyl tubing.	—	—	UG-372/U
	Slide hood over braid* and force under vinyl. Place inner conductor in contact sleeve and solder. Push hood flush against receptacle. Tack-solder hood to braid through solder holes. Tape this junction or use vinyl tubing. *When using RG-9/U, hood goes over inner braid only. Outer braid is soldered on outside of hood.	—	UG-106/U	—

MIL-HDBK-216
SECTION 3A
18 May 1965

ASSEMBLY PROCEDURES FOR TPS CONNECTORS

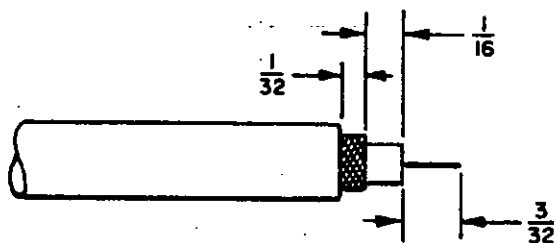

1. CAREFULLY TRIM CABLE TO DIMENSIONS SHOWN.

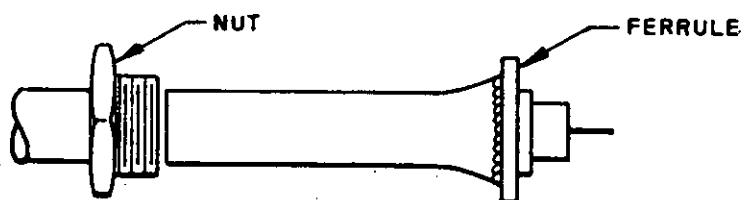

2. SLIP NUT OVER CABLE AND SLIDE FERRULE UNDER OUTER BRAID.

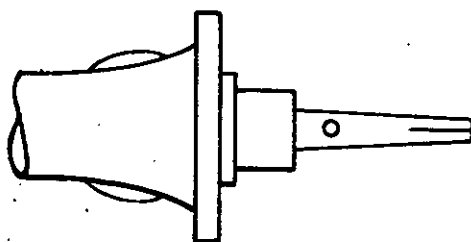

3. SOLDER CONTACT ONTO INNER CONDUCTOR.

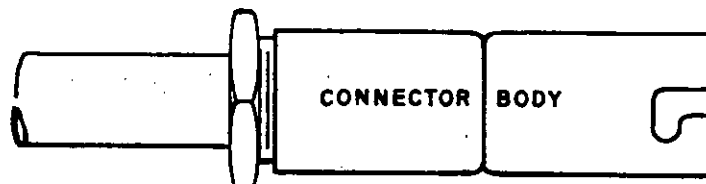

4. SCREW NUT INTO CONNECTOR BODY OR CONNECTOR BODY INTO NUT.

Prior to assembly with connectors, cables (cut slightly longer than required for final assembly) should be dimensionally stabilized in an oven for 20 hours (maximum) at 85°C. When the cable has cooled to room temperature, look for differences in length between center conductor, core, and jacketing at each end of the cable. If the core or jacket has shrunk, cut the end flush and repeat the above stabilization procedure until no further shrinkage occurs.

MIL-HDBK-216
SECTION 3A
18 May 1965

VSWR DATA ON TYPE "C" COAXIAL CONNECTORS FROM
THE POLYTECHNIC INSTITUTE OF BROOKLYN

TYPE "C" CONNECTOR FOR RG-9/U
FREQUENCY (KMC/SEC.) V.S.W.R.

9.90.....	1.13
9.34.....	1.10
8.70.....	1.07
7.08.....	1.10
5.92.....	1.05
5.22.....	1.05
4.52.....	1.08
3.96.....	1.04
2.95.....	1.03

TYPE "C" CONNECTOR FOR RG-17/U
FREQUENCY (KMC/SEC.) V.S.W.R.

1.52.....	1.14
1.80.....	1.13
2.20.....	1.15
2.43.....	1.22
2.60.....	1.08
2.90.....	1.05
3.70.....	1.195

TYPE "C" CONNECTOR FOR RG-14/U
FREQUENCY (KMC/SEC.) V.S.W.R.

2.135.....	1.08
2.46.....	1.135
3.175.....	1.11
3.925.....	1.043
4.85.....	1.063
6.04.....	1.19
7.44.....	1.22
8.4.....	1.285
9.46.....	1.44

TYPE "C" PRESSURIZED CONNECTOR
(SMALL HEAD)

FREQUENCY (KMC/SEC.)	V.S.W.R. (AVERAGE OF 2 SAMPLES)
10.0.....	1.48
7.18.....	1.13
4.82.....	1.18
3.94.....	1.15
3.68.....	1.18
2.39.....	1.10

VSWR DATA ON IMPROVED "BNC" CONNECTORS FROM
THE POLYTECHNIC INSTITUTE OF BROOKLYN

IMPROVED TYPE "BNC" CONNECTOR FOR RG-58/U
FREQUENCY (KMC/SEC.) V.S.W.R.

9.90.....	1.10
8.80.....	1.21
7.52.....	1.10
6.41.....	1.15
5.15.....	1.07
4.12.....	1.08
3.71.....	1.07
2.96.....	1.09
2.40.....	1.06

NOTE: Data taken by Polytechnic Institute of Brooklyn is based on some very accurate measurements made on units manufactured to tolerances not currently specified to date.

MLL-HDBK-216
SECTION 3A
18 May 1965

VSWR DATA ON IMPROVED TYPE "N" COAXIAL CONNECTORS FROM
THE POLYTECHNIC INSTITUTE OF BROOKLYN

IMPROVED TYPE "N" CONNECTOR FOR RG-5/U
V.S.W.R.
FREQUENCY (KMC/SEC.) (AVERAGE OF
2 SAMPLES)

2.575.....	1.14
2.970.....	1.09
3.401.....	1.09
4.009.....	1.07
4.608.....	1.08
5.451.....	1.09
6.459.....	1.11
7.009.....	1.11
8.481.....	1.20
9.980.....	1.42

IMPROVED TYPE "N" STRAIGHT ADAPTERS
V.S.W.R.
FREQUENCY (KMC/SEC.) (AVERAGE OF
2 SAMPLES)
PLUG-TO-PLUG JACK-TO-JACK

9.97.....	1.22.....	1.07
8.45.....	1.06.....	1.13
6.67.....	1.05.....	1.04
5.39.....	1.05.....	1.06
4.46.....	1.08.....	1.08
3.83.....	1.06.....	1.03
3.15.....	1.14.....	1.11
2.58.....	1.03.....	1.03

IMPROVED TYPE "N" CONNECTOR FOR RG-8,9/U
V.S.W.R.
FREQUENCY (KMC/SEC.) (AVERAGE OF
2 SAMPLES)

3.024.....	1.07
3.550.....	1.09
4.531.....	1.10
5.549.....	1.23
6.723.....	1.25
7.875.....	1.08
9.527.....	1.078
11.676.....	1.09

IMPROVED TYPE "N" RIGHT ANGLE CONNECTORS
V.S.W.R.
FREQUENCY (KMC/SEC.) (AVERAGE OF
3 SAMPLES)

10.0.....	1.14
7.18.....	1.05
4.82.....	1.09
3.94.....	1.08
3.68.....	1.10
2.86.....	1.08
2.39.....	1.07

IMPROVED TYPE "N" CONNECTOR FOR RG-14/U
V.S.W.R.
FREQUENCY (KMC/SEC.) (AVERAGE OF
2 SAMPLES)

9.96.....	1.13
8.96.....	1.07
7.87.....	1.05
7.01.....	1.10
5.98.....	1.07
4.96.....	1.13
3.97.....	1.12
3.31.....	1.05
2.70.....	1.08

MIL-HDBK-218
SECTION 3A
18 May 1965

VSWR DATA ON IMPROVED TYPE "HN" COAXIAL CONNECTORS FROM
THE POLYTECHNIC INSTITUTE OF BROOKLYN

FREQUENCY (KMC/SEC)	V.S.W.R. (AVERAGE OF 3 SAMPLES)
1.766.....	1.07
2.003.....	1.12
2.508.....	1.11
3.010.....	1.03
3.371.....	1.21
3.378.....	1.27
3.759.....	1.26
3.967.....	1.20
4.225.....	1.07*
4.498.....	1.36*
4.970.....	1.97*

*Designed for a maximum frequency of 4.0 KMC/SEC.

MIL-HDBK-216
SECTION 3A
18 May 1965

VSWR Data on Type "SC" Coaxial Connectors from Navy Contract NObsr-89294

TYPE SC Connector for RG-9/U

Frequency (KMC/SEC)	VSWR (Avg of 10 samples)
1.0	1.027
3.0	1.064
5.0	1.05
10.0	1.054

Attenuation Data on Types N, C, and N, C, and SC Coaxial Connectors from Navy Contract NObsr-89294.

TYPE N Connector for RG-9/U

Frequency (KMC/SEC)	Attenuation (db) (Avg of 10 samples)
1.0	.0045
3.0	.0168
5.0	.0263
10.0	.0375

TYPE C Connector for RG-9/U

Frequency (KMC/SEC)	Attenuation (db) (Avg of 10 samples)
1.0	.0095
3.0	.0132
5.0	.0189
10.0	.0285

TYPE SC Connector for RG-9/U

Frequency (KMC/SEC)	Attenuation (db) (Avg of 10 samples)
1.0	.0074
3.0	.0163
5.0	.0272
10.0	.0255

SECTION 4B

SWITCHES, COAXIAL AND WAVEGUIDE

4.1 General consideration.

a. Radio frequency switches are designed to quickly connect, disconnect, or interconnect RF lines with any combination of antennas, receivers, transmitters, dummy loads, etc. Their design must enable optimum operation over the frequency range they are intended for.

b. Dependability, during all forms of service environment conditions, is one of the important features in the selection of a switch. Other important considerations should cover bandwidth, voltage standing wave ratio, insertion losses, RF leakage, cross-coupling attenuation, and power handling capabilities. Also of importance are speed of actuation, if remotely controlled, life expectancy, size, weight, and general adaptability to the system.

4.1.1 Coaxial switches. These switches are used in conjunction with preferred RF connectors and cables. They may be operated manually or electrically by remote control. They are available in a varied number of switching positions and are often designed for specific applications. Table 4.I contains those switches that are covered by military specification and are included in MIL-STD-1329. Table 4.II contains switches that are either covered by a military specification or Federal Stock Number and are not included in MIL-STD-1329. Table 4.III contains coaxial switches that have been approved as non-standard parts for military systems but are not covered by a military specification.

4.1.2 Waveguide switches. These switches are used in conjunction with standard type waveguides. They may be operated manually or electrically by remote control. They are available in a varied number of switching positions and are often designed for specific applications. Table 4.IV contains switches that have been assigned AN nomenclature. Table 4.V contains switches that have been approved as nonstandard parts for military systems but are not covered by a military specification.

MIL-HDBK-216
Section 4B

TABLE 4.1. Guide to selection of preferred coaxial switches.

Part number	Type SA-()/U	Bandwidth DC-GHz	Connector type	Actuation type	Operation voltage (nominal)	Configuration	Position indicating circuit	Actuator connector
M3928/								
6-01	1363	0.4	N	Solenoid	28 Vdc	1P2T	None	Solder terminals
-02	1364	0.4	N	Solenoid	110 Vdc	1P2T	None	Solder terminals
-03	1365	0.4	N	Solenoid	115 Vac	1P2T	None	Solder terminals
-04	1366	0.4	N	Manual	---	1P2T	None	---
7-01	1320	10	N	Solenoid	115 Vac	1P2T	None	MS3456-10SL-3S 2/
-02	1321	10	N	Manual	---	1P2T	None	---
-03	185	10	N	Solenoid	26 Vdc	1P2T	None	MS3456-10SL-3S 2/
-04	1323	10	N	Solenoid	115 Vac	1P3T	None	MS3456-14S-2S 2/
-05	1324	10	N	Solenoid	26 Vdc	1P3T	None	MS3456-14S-2S 2/
-06	1325	10	N	Manual	---	1P6T	None	---
-07	1326	10	N	Solenoid	26 Vdc	1P6T	None	MS3456-16S-1S 2/
-08	1327	10	N	Solenoid	115 Vac	1P6T	None	MS3456-16S-1S 2/
-09	1328	10	N	Solenoid	110 Vdc	1P2T	None	.138-32UNC-2A
-10	1329	10	BNC	Solenoid	26 Vdc	1P2T	None	.138-32UNC-2A
-11	1330	10	N	Solenoid	110 Vdc	1P3T	None	MS3456-14S-2S 2/
-12	1331	10	N	Manual	---	1P3T	None	---
-13	1332	10	BNC	Manual	---	1P6T	None	---
-14	273	10	N	Manual	---	1P2T	None	---
-15	275	10	N	Manual	---	1P6T	None	---
-16	274	10	N	Manual	---	1P4T	None	---
-17	---	10	N	Solenoid	26 Vdc	1P2T	None	.138-32UNC-2A
-18	---	10	N	Solenoid	26 Vdc	1P2T	None	.138-32UNC-2A
-19	---	10	N	Solenoid	110 Vdc	1P2T	None	.138-32UNC-2A
-20	---	10	N	Solenoid	28 Vdc	1P2T	None	.138-32UNC-2A
-21	---	10	N	Solenoid	115 Vac	1P2T	None	.138-32UNC-2A
-22	---	10	N	Manual	---	1P4T	None	---
-23	---	10	BNC	Solenoid	115 Vac	1P2T	None	.138-32UNC-2A
-24	---	10	N	Solenoid	28 Vdc	1P4T	None	.138-32UNC-2A
-25	---	12.4	N	Solenoid	28 Vdc	TR	None	MS83723-13R1006N
-26	---	12.4	N	Solenoid	28 Vdc	TR	Yes	MS83723-13R1006N
8-01	1348	1.55	BNC	Solenoid	28 Vdc	TR	None	Solder terminals
-03	1350	1.55	BNC	Solenoid	28 Vdc	1P2T	None	Solder terminals
-05	1352	1.55	BNC	Solenoid	115 Vac	1P2T	None	Solder terminals

See footnotes at end of table.

TABLE 4.1. Guide to selection of preferred coaxial switches - Continued.

Part number	Type SA-()/U	Bandwidth DC-GHz	Connector type	Actuation type	Operation voltage (nominal)	Configuration	Position indicating circuit	Actuator connector
MS928/								
8-07	1354	1.55	BNC	Solenoid	110 Vdc	1P2T	None	Solder terminals
-17	---	2	BNC	Solenoid	28 Vdc	1P2T	None	Solder terminals
-18	---	4	BNC	Solenoid	28 Vdc	1P2T	None	Solder terminals
-19	---	4	BNC	Solenoid	28 Vdc	1P2T	None	Solder terminals
-20	---	6	BNC	Solenoid	28 Vdc	1P2T	None	Solder terminals
-21	---	3	BNC	Manual	---	1P6T	None	---
9-01	303	10	N	Motor	28 Vdc	1P2T	None	MS3456W-14S-5S 2/
-02	1334	10	N	Motor	28 Vdc	TR	None	MS3456W-14S-5S 2/
-03	1335	10	N	Motor	28 Vdc	1P3T	None	MS3456W-14S-2S 2/
-04	1336	10	N	Manual	---	2P2T	None	---
-05	1337	10	N	Manual	---	1P2T	None	---
-06	1338	10	N	Motor	115 Vac	1P2T	None	MS3456W-10SL-3S 2/
-07	1339	10	N	Motor	115 Vac	1P3T	None	MS3456W-14S-2S 2/
-08	1340	10	N	Motor	115 Vac	1P6T	None	MS3456W-16S-1S 2/
-09	1341	10	N	Motor	115 Vac	TR	None	MS3456W-10SL-3S 2/
-10	1342	10	N	Motor	115 Vac	2P2T	None	MS3456W-10SL-3S 2/
-11	1343	10	N	Motor	28 Vdc	2P2T	None	MS3456W-14S-5S 2/
-12	1344	10	N	Motor	28 Vdc	1P6T	None	MS3456W-14S-5S 2/
-13	1345	10	N	Manual	---	TR	None	---
-14	1346	10	N	Manual	---	1P3T	None	---
-15	1347	10	N	Manual	---	1P6T	None	---
-17	---	12.4	N	Motor	28 Vdc	TR	Yes	MS3452W-12-10S 2/
10-01	1360	5.2	N	Solenoid	110 Vdc	1P2T	None	Solder terminals
-02	1361	5.2	N	Solenoid	28 Vdc	1P2T	None	Solder terminals
-03	1362	5.2	N	Solenoid	115 Vac	1P2T	None	Solder terminals
-04	---	12.4	N	Solenoid	28 Vdc	1P2T	None	Solder terminals
-05	---	12.4	N	Solenoid	28 Vdc	1P2T	Yes	Solder terminals
12-01	---	2	TNC	Solenoid	28 Vdc	1P2T	Yes	MS27478-Y8D6P
13-01	---	2	TNC 3/	Solenoid	28 Vdc	1P2T	Yes	Solder terminals
14-01	---	12.4	TNC	Solenoid	28 Vdc	TR	Yes	MS27466-T9B6P
15-01	---	18	SMA	Solenoid	28 Vdc	1P2T	None	Solder terminals
-02	---	18	SMA	Solenoid	28 Vdc	1P2T	None	Solder terminals
-03	---	18	SMA	Solenoid	28 Vdc	1P2T	None	Solder terminals
-04	---	18	SMA	Solenoid	28 Vdc	1P2T	Yes	Solder terminals

See footnotes at end of table

MIL-HDBK-216
Section 4B

TABLE 4. I. Guide to selection of preferred coaxial switches - Continued.

Part number I/	Type SA-()/U	Bandwidth DC-GHz	Connector type	Actuation type	Operation voltage (nominal)	Configuration	Position indicating circuit	Actuator connector
M3928/								
15-05	---	18	SMA	Solenoid	28 Vdc	1P2T	Yes	Solder terminals
-06	---	18	SMA	Solenoid	28 Vdc	1P2T	None	Solder terminals
-07	---	18	SMA	Solenoid	28 Vdc	1P2T	None	Solder terminals
-08	---	18	SMA	Solenoid	28 Vdc	1P2T	Yes	Solder terminals
16-01	---	18	SMA	Solenoid	28 Vdc	1P3T	Yes	MS3114E-12-10P
17-01	---	18	SMA	Solenoid	28 Vdc	1P4T	Yes	M8372311-H1210N
17-02	---	18	SMA	Solenoid	28 Vdc	1P4T	None	RTK07-8-7P (Deutch or equivalent)
18-01	---	18	SMA	Solenoid	28 Vdc	1P6T	None	RTK07-8-7P (Deutch or equivalent)
-02	---	18	SMA	Solenoid	28 Vdc	1P6T	None	Solder terminals
19-01	---	12.4	SMA	Solenoid	28 Vdc	TR	Yes	Solder terminals
-02	---	12.4	SMA	Solenoid	28 Vdc	TR	None	Solder terminals
-03	---	18	SMA	Solenoid	28 Vdc	TR	Yes	Solder terminals
-04	---	12.4	SMA	Solenoid	28 Vdc	TR	None	Solder terminals
20-01	---	12.4	TNC	Solenoid	28 Vdc	1P2T	Yes	Solder terminals
-02	---	6	TNC	Solenoid	28 Vdc	1P2T	None	MS3113H-10C-6P
-03	---	11	TNC	Solenoid	28 Vdc	1P2T	None	Solder terminals
-04	---	11.25	TNC	Solenoid	28 Vdc	1P2T	None	MS3113-8-2P
-05	---	0.4	TNC	Solenoid	28 Vdc	1P2T	Yes	Solder terminals
-06	---	12.4	TNC	Solenoid	28 Vdc	1P2T	Yes	Solder terminals
21-01	---	11	TNC	Solenoid	28 Vdc	TR	None	MS3116E-8-3S 2/
21-02	---	12.4	TNC	Solenoid	28 Vdc	TR	Yes	Solder terminals
M24067/								
1-001	---	1.075	N	Solenoid	28 Vdc	1P2T	Yes	MS3102R-14S-6P
2-001	---	1.075	N	Solenoid	28 Vdc	2P2T	Yes	MS3102R-14S-5P
---	521A/A 4/	1.250	N	Solenoid	28 Vdc	1P2T	None	MS3106-10SL-3S 2/

1/ Part number is derived from military specification number, applicable specification sheet and dash number.

2/ Connector mates with.

3/ Center connector (common) is series SC.

4/ MIL-S-25879 applies.

TABLE 4.II. Nonstandard nomenclatured RF coaxial switches.

Type	Description	Bandwidth GHz	Female termination (series)	Method of actuation	Engineering data
SA-14/SPR-1	12-position	.04 - 3.0	N	Manual	---
SA-74	6-position	---	N	Manual	---
SA-131	6-position	.10 - 4.0	N	Manual	---
SA-189	2-position	---	N	Manual	---
SA-215	2-position	---	N	Manual	---
SA-304	2-position	DC - 3.0	BNC	Manual	---
SA-325/U	1P4T	---	N	Motor	28 Vdc
SA-1563/U	1P6T	DC - .035	C	Manual	---
SA-739/APS-96	2-position	---	---	Solenoid	28 Vdc

TABLE 4.III. Coaxial switches approved as nonstandard parts.

Equip part or dwg no.	Vendor code	Description	Bandwidth (GHz)	RF connector type	Method of actuation	Other data
G330156S1	24930	1P2T	DC - 10	N	Solenoid	115 Vac
119844-1	94987	1P2T	DC - 0.5	N	Solenoid	28 Vdc (indicator circuit)
247AS-C0773-001	30003	1P6T	DC - 12.0	N	Solenoid	28 Vdc (indicator circuit)
S30141-1	05395	TR	DC - 12.4	N	Solenoid	28 Vdc (indicator circuit)
K80-0001-000	14304	1P2T	DC - 0.5	BNC	Solenoid	28 Vdc
712018-1	49956	1P2T	DC - 12.4	TNC	Solenoid	28 Vdc
20A0243003	31804	1P2T	DC - 12.4	TNC	Solenoid	28 Vdc
S30139-1	05395	1P2T	DC - 12.4	TNC	Solenoid	28 Vdc
G330150S1	24930	1P2T	---	MB	Solenoid	Termination grounded 28 Vdc
800C50800	82152	1P2T	---	SC	Solenoid	28 Vdc (indicator circuit)
135C50900	82152	1P5T	DC - 0.4	SC	Solenoid	28 Vdc (indicator circuit)
909C70100	82152	1P2T	DC - 18.0	SMA	Solenoid	28 Vdc
42-004028	30890	1P2T	DC - 12.4	SMA	Solenoid	---
123906	94987	1P2T	DC - 1.5	SMA	Solenoid	28 Vdc (triggered)
584071	49956	TR	9.0 - 9.2	SMA	Solenoid	28 Vdc (indicator circuit)
20-807756-1	07397	TR	DC - 18.0	SMA	Solenoid	115 Vac (indicator circuit)
581R958H01	97942	TR	DC - 18.0	SMA	Solenoid	28 Vdc (indicator circuit)
239005P2	94117	1P2T	DC - 6.0	SMC	Solenoid	115 Vac (terminated)
239005P1	94117	1P2T	DC - 3.0	SMC	Solenoid	115 Vac (terminated)

MIL-HDBK-216
Section 4B

TABLE 4.IV. Nomenclatured waveguide switches.

Type	Number of ports	Actuation type	Nominal operating voltage	Frequency range (GHz)	Data
			<u>volts</u>		
SA-222/UP	3	Motor	28 dc	2.6 - 3.95	---
SA-511/U	3	Solenoid	28 dc	8.5 - 9.6	---
SA-512/U	3	Solenoid	28 dc	8.5 - 9.6	---
SA-583/U	3	Solenoid	115 ac	13.0 - 17.0	---
SA-605/U	3	Solenoid	28 dc	7.05 - 10.0	---
SA-1260/U	2	Solenoid	28 dc	7.0 - 11.0	For use with RG-320/U Monel body

TABLE 4.V. Waveguide switches approved as nonstandard parts.

Equip part or dwg no.	Vendor code	Description	Bandwidth (GHz)	R.F. flange	Method of actuator	Other data
G330157S1	24930	1P2T	2.6 - 3.95	M3922/61-001 1/	Manual	Ind ckt
723327-1	05869	1P2T	10.8 - 18.0	M3922/53-005 1/	Solenoid	Ind ckt 28 Vdc
712401-1	05869	1P2T	11.0 - 17.0	M3922/53-006 1/	Solenoid	Ind ckt 28 Vdc
20-811080-1	07397	1P2T	11.25- 18.0	M3922/53-005 1/	Solenoid	5 position 28 Vdc
531639-1	96214	1P2T	16.2 - 16.8	M3922/59-002	Solenoid	Interlock 28 Vdc
885C052589-1	34228	1P2T	18.0 - 26.5	M3922/54-002 1/	Manual	---
885C052568-1	34228	1P2T	26.5 - 40.0	M3922/54-003 1/	Manual	---
927050-4B	82577	1P3T	8.2 - 12.4	M3922/53-003 2/	Motor	Ind ckt 28 Vdc
20-808750-2	07397	TR	8.0 - 12.0	M3922/59-008	Solenoid	Ind ckt 28 Vdc
8998738-1	49671	TR	8.2 - 12.4	M3922/53-003 1/	Solenoid	Ind ckt 28 Vdc
584077-1	49956	TR	9.0 - 9.2	M3922/59-009	Solenoid	Ind ckt 28 Vdc
20-808750-1	07397	TR	12.0 - 18.0	M3922/59-001	Solenoid	Ind ckt 28 Vdc
120225-1	94987	TR	12.4 - 18.0	M3922/59-002	Solenoid	Ind ckt 28 Vdc
203373-000	81413	TR	26.5 - 40.0	M3922/54-003 1/	Solenoid	28 Vdc

1/ Mates with.

2/ Except threaded holes.

★ U. S. GOVERNMENT PRINTING OFFICE: 1974 - 603-113/3398

MIL-HDBK-216
SECTION 5A
7 April 1967
SUPERSEDING
Section 5
4 January 1962

SECTION 5A

RIGID COAXIAL TRANSMISSION LINES

5.1 General considerations

Bead-supported coaxial lines are those in which the center conductor is supported and aligned by the use of low-loss dielectric beads within the outer shell. Although largely replaced by solid-dielectric flexible coaxial cable, they still retain an advantage for permanent installations where ruggedness and high power capacity are prime considerations. They are available in many commercial sizes which have been found satisfactory for most applications.

Stub-supported coaxial lines are those in which the inner conductor is supported and positioned within the outer shell by means of shorted stubs placed at strategic intervals along the line. Each stub is a quarter wavelength line shorted at the outer end, connected to the line both by center and outer conductors, and is oriented 90° to the direction of the main line. The stubs present a very high impedance in shunt with the line and introduce a negligible amount of power loss. Their main disadvantage is that a specific line can only be used over the very narrow band of frequencies for which the stubs are effectively a quarter wavelength.

Bead-supported coaxial lines which mate with each of the stub-supported sizes have been made or can be made. These lines, when constructed with properly designed undercut or overcut supporting beads, have broad-band characteristics and can be used in connection with or as replacements for stub-supported lines. These lines have, to date, been made for special applications only.

5.2 Tables

This part lists those rigid coaxial transmission lines currently used by the Armed Services.

MIL-HDBK-216
SECTION 5A
7 April 1967

TABLE 5.1. Bead supported coaxial lines.

Type	Over-all diameter inches	Inner conductor	Supporting Insulation		Bead diameter inches	Minimum bend radius inches	Weight lbs/100 ft	Nominal impedance ohms	Nominal capacitance pf/ft.	Propagation constant at 100 (MHz) percent	Average attenuation at 100 (MHz) db/ft	Maximum voltage rating volts	Recommended rating input at 100 (MHz) watts	Maximum total power at 100 (MHz) watts	Engr. data
			Spacing	Material											
	0.250	0.051-inch-diameter solid copper wire	2-1/2 turn per inch	Polyethylene	0.200	3	8.25	75	14.5	88.7	0.015	1,000	750	1,350	
	0.375	0.081-inch-diameter solid copper wire	2 inches	Steatite	0.311	8	15.75	72	14.5	86.2	0.011	2,900	1,500	3,000	
RG-162/U	3.065	0.156-inch-diameter copper tube		Polytetrafluoroethylene				175				30,000			
	0.875	0.250-inch-diameter copper tube	6 inches	Steatite	0.785		60.0	65	18.4	87.6	0.005	7,000	4,000	5,250	
	0.875	0.250-inch-diameter copper tube	3 inches	Steatite	0.785	5	60.0	65	18.4	87.6	0.005	7,000	4,000	5,250	
RG-92/U	0.875	0.375-inch-diameter copper tube		Polytetrafluoroethylene	0.812			46				4,000			
RG-80/U	0.9375	0.375-inch-diameter copper tube						51							
	1.625	0.625-inch-diameter copper tube	6 inches	Steatite	1.527		125.0	50	23.4	86.8	0.003	11,000	9,000	10,000	
N.T. 62200	1.625	0.638-inch-diameter copper tube	3 inches	Polytetrafluoroethylene	1.527		125.0	50	20.5	94.9	0.002	11,000	9,000	10,000	
	3.125	0.875-inch-diameter copper tube	12 inches	Steatite	3.027		230.0					21,500	25,000	25,500	
	3.125	0.875-inch-diameter copper tube	6 inches	Teflon	3.027		241.00					21,500	25,000	25,500	See note
CG-719/U	6.125	2.50-inch-diameter copper tube		Steatite	5.981			51.5	19.7						
CG-720/U	3.125	1.20-inch-diameter copper tube		Steatite	3.027		290.00	51.5	20.1						
RG-128/U	1.625	0.684-inch-diameter		Steatite				50		99.0	0.006	11,000			
RG-134/U	0.450	One, solid, copper 28AWG		Polytetrafluoroethylene interlocked polytetrafluoroethylene				185	6.5			1,000			flexible brass tubing

1/ With line at atmospheric pressure.

2/ Total input based on center-conductor temperature of 200° F., ambient 76° C.

3/ Thread, helically wrapped.

NOTE: See NAVSHIPS 900-579 for installation instructions.

MIL-HDBK-216
SECTION 5A
7 April 1967

TABLE 5.II. Physical requirements.^{1/}

TYPE	Line size	Outer conductor				Inner conductor			
		Diameter		Wall thickness		Diameter		Wall thickness ^{2/}	
		A	B	Nominal	Maximum deviation from average ^{2/}	C	D	Nominal	Maximum deviation from average ^{3/}
RG-152/U	6-1/8	6.125 ±.008	5.981 ±.008	0.072	0.012	2.600 ±.004	2.520 ±.004	0.040	0.0075
RG-154/U	3-1/8	3.125 ±.005	3.027 ±.005	0.049	0.0075	1.315 ±.003	1.231 ±.003	0.042	0.005
RG-153/U	1-5/8	1.625 ±.003	1.527 ±.003	0.049	0.005	0.6640 ±.0025	0.5880 ±.0025	0.038	0.005
RG-155/U	7/8	0.8750 ±.0025	0.7850 ±.0025	0.045	0.005	0.341 ±.002	0.291 ±.002	0.025	0.003
RG-151/U	3/8	0.375 ±.002	0.285 ±.002	0.045	0.0045	0.125 ±.002	---	Rod	---

^{1/} All dimensions are in inches.

^{2/} Average wall thickness is one-half the difference between the corresponding inside and outside diameters at any cross section perpendicular to the axis.

^{3/} Maximum deviation of the wall thickness from the average wall thickness (eccentricity) at any cross section is the difference between the average wall thickness and either the maximum or minimum wall thickness, whichever is greater.

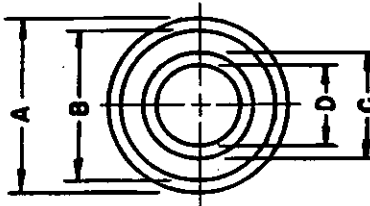

MIL-HDBK-216
SECTION 5A
7 April 1967

TABLE 5.III. Electrical requirements.

TYPE	Frequency range, incl. (MHz)	Iterative impedance ^{1/} (ohms)			VSWR ^{2/}	High potential test voltage (kv rms)	Transducer loss	
		Nominal	Max.	Min.			db/100 ft	Test frequencies (MHz)
RG-152/U	0.5 to 650	50	50.15	49.82	1.10:1	30.0	0.140	500
RG-154/U	0.5 to 1,300	50	50.26	49.73	1.10:1	15.0	0.330	800
RG-153/U	0.5 to 2,700	50	50.31	49.64	1.10:1	8.0	1.00	2,000
RG-155/U	0.5 to 3,300	50	50.57	49.48	1.10:1	4.0	2.20	2,000
RG-151/U	0.5 to 10,000	50	50.83	48.07	1.10:1	0.5	15.0	10,000

^{1/} The iterative impedance for each line size, as shown, is exclusive of supports, and is for informational purposes.

^{2/} VSWR tests shall be conducted on 20-foot lengths, minimum.

TABLE 5.IV. TE₁₁ mode cutoff frequency (GHz)

Line size	Air line	Undercut teflon	Overcut teflon	Undercut polystyrene	Overcut polystyrene
6-1/8	0.895	0.686	0.472	0.640	0.390
3-1/8	1.768	1.355	0.932	1.264	0.770
1-5/8	3.505	2.686	1.847	2.506	1.526
7/8	6.818	5.223	3.593	4.873	2.968
3/8	18.800	14.387	9.895	13.422	8.175

NOTE: For further information see MIL-L-3890 and EIA Standard TR-134.

MIL-HDBK-216
SECTION 5A
7 April 1967

TABLE 5.V. Stub-supported coaxial lines.

Type	Nominal impedance	Outer conductor		Inner conductor		Engineering data
		Outside diameter	Wall thickness	Outside diameter	Wall thickness	
	<u>ohms</u>	<u>inches</u>	<u>inch</u>	<u>inch</u>	<u>inch</u>	
RG-44/U	50	7/8	0.032	0.375	0.032	
RG-45/U	50	1-1/4	0.049	0.500	0.032	
RG-46/U	50	1-5/8	0.049	0.625	0.035	
RG-47/U	50	1/2	0.032	0.1875	0.032	
RG-76/U	50	5/8	0.032	0.250	0.022	
	50	5/16	0.025	0.125	0.032	
	50	3/8	0.090	0.125		
	70	7/8	0.042	0.250	0.032	
	70	7/8	0.032	0.250	0.022	
	70	7/8	0.045	0.2187	0.032	

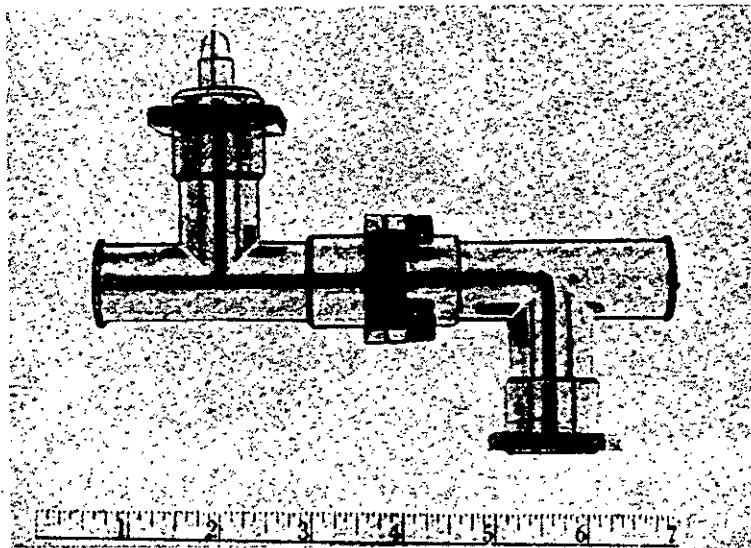

SECTION 6B

WAVEGUIDES

6.1 General waveguide considerations.

6.1.1 Modes. Electromagnetic energy can propagate through a hollow metallic tube or waveguide with many possible configurations of electric and magnetic fields; each specific configuration is known as a "mode". The particular mode which is transmitted within a waveguide depends on the excitation employed, and on the size and shape of the waveguide cross section in relation to the wavelength or frequency of the wave. Modes are classified in reference to the field components in the direction of energy propagation. A mode is identified by two numerical subscripts (TE_{mn} or TM_{mn}) that denote the number of half-wave field variations in the width (a) and height (b) dimensions of the rectangular waveguide. For circular waveguides, the cylindrical coordinates are used where "m" is the variation in the θ direction and "n" in the ρ direction. For elliptical cross section waveguides, elliptic coordinates are employed with the subscript preceding referring to odd (o) or even (e) and the "m" and "n" referring to the number of half-wave field variations in the elliptical and hyperbolic directions. For most applications, these dimensions are chosen so that only the dominant mode, that is, lowest frequency or longest wavelength, will propagate. At any abrupt change in the waveguide cross section or obstacle, evanescent (higher order) modes may be excited but they are attenuated very rapidly in the dominant mode guide at a short distance from the discontinuity. A cross-section view of the more popular modes is illustrated in figures 6.1, 6.2, and 6.3. In the transverse plane, the lines of magnetic flux are always orthogonal to those of the electric field.

6.1.1.1 TE (transverse electric) modes. The electric field components are contained in a plane normal to the direction of propagation. As the magnetic field has a component in the direction of propagation, that is, along the waveguide axis, these modes are also called "H" waves.

6.1.1.2 TM (transverse magnetic) modes. The magnetic field components are contained in a plane normal to the direction of propagation. The electric field has a component in the direction of propagation, and for this reason these modes are also called "E" waves.

6.1.2 Cutoff wavelength. Propagation cannot occur in waveguides if the operating wavelength is greater than the cutoff wavelength, λ_c , for the dominant mode. For wavelengths greater than λ_c , the guide is unable to support a traveling wave and its attenuation increases exponentially with length.

6.1.2.1 Rectangular waveguide cutoff wavelength. In air-filled rectangular guides for all TE and TM modes the cutoff wavelength is given by:

$$\lambda_c = \frac{2}{\sqrt{\left(\frac{m}{a}\right)^2 + \left(\frac{n}{b}\right)^2}}$$

For the TE_{10} or dominant mode λ_c reduces to $2a$. The cutoff wavelength for the next higher mode (TE_{20}) is equal to "a" resulting in a bandwidth of 2:1 ratio of theoretical upper and lower frequencies of the pass band for the dominant mode. It is customary to operate waveguides no lower than 25 percent above TE_{10} cutoff due to the rapid increase in attenuation, or 5 percent below the TE_{20} cutoff to prevent possible mode conversion. Common practice conforms to this recommendation, resulting in bandwidths which are about 40 percent^{1/}. The optimum value of "b" is recommended to be $a/2$ or $\lambda_c/4$.

^{1/} Bandwidths may be expressed as a percentage equal to $200 (f_2 - f_1) / (f_1 + f_2)$ where f_1 is the lower frequency and f_2 the upper frequency.

MIL-HDBK-216
SECTION 6B
12 June 1975

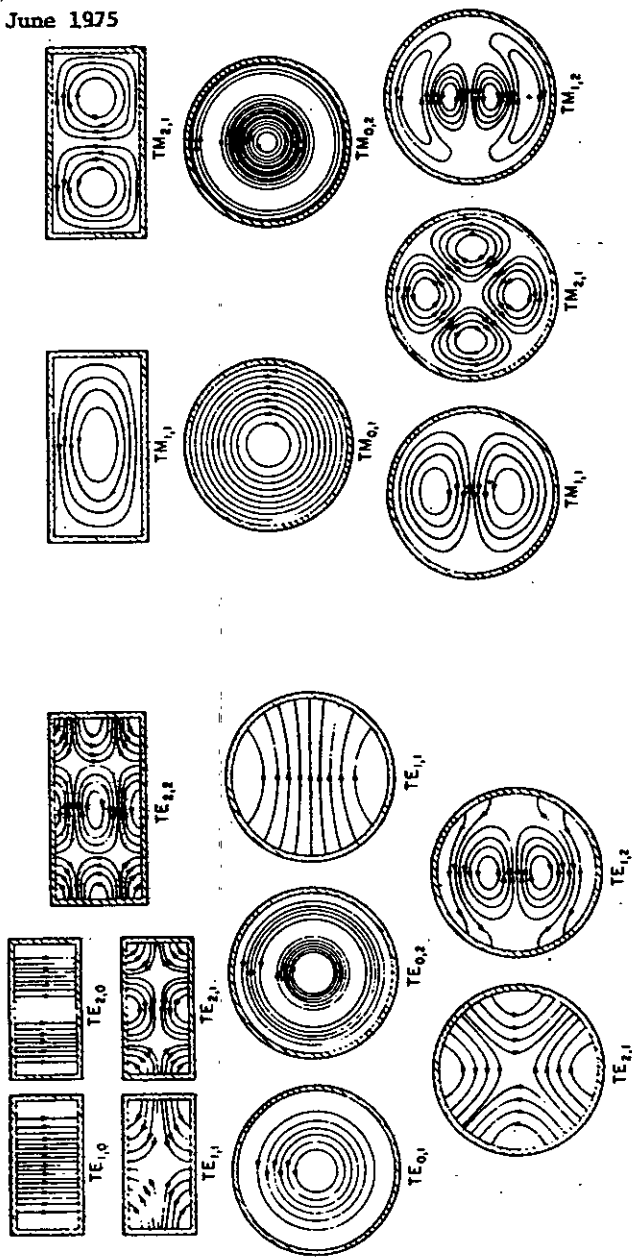

FIGURE 6.1. Cross-section view of the configuration of electric field for common TE modes in rectangular and circular waveguides.

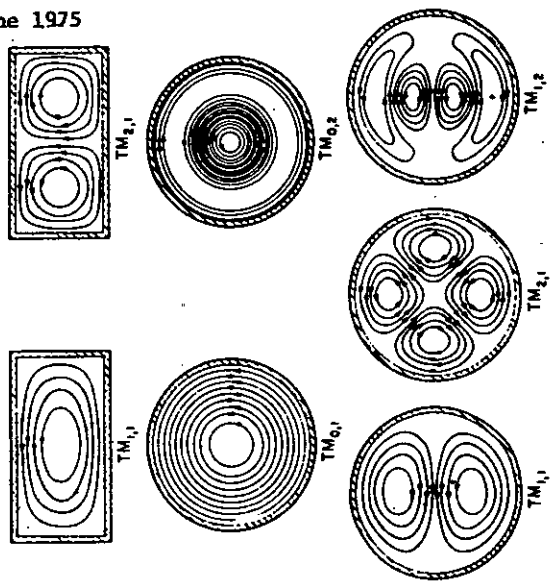

FIGURE 6.2. Cross section view of the configuration of magnetic field for common TM modes in rectangular and circular waveguides.

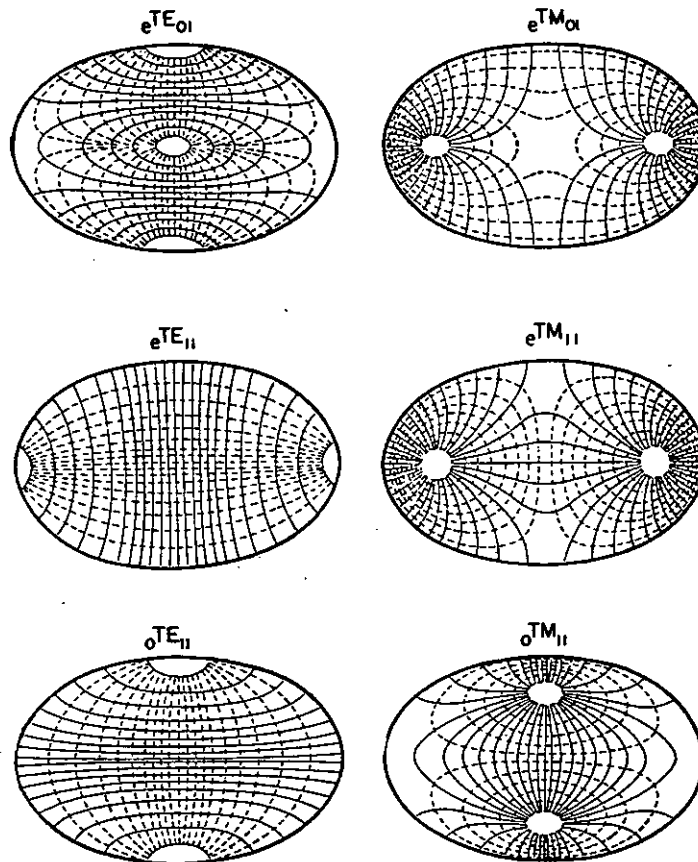

FIGURE 6.3. Field distribution of modes in elliptical waveguide. Cross-sectional view.

(Solid line = electric field, dashed lines = magnetic field)

MIL-HDBK-216
SECTION 6B
12 June 1975

6.1.2.2 Circular waveguide cutoff wavelength. For circular waveguides, the cutoff wavelengths are determined by the radius "a" of the guide and the roots of the Bessel function, U_{mn} . Table 6.I gives the values of λ_c/a for TE_{mn} and TM_{mn} waves. Circular waveguides operating in the dominant TE_{11} mode have a theoretical unimodal bandwidth of 23 percent with a recommended bandwidth of 32 percent since the TM_{11} mode can easily be avoided by maintaining symmetry. Care must also be exercised to avoid polarization loss.

TABLE 6.I. Normalized cutoff wavelengths
(λ_c/a for circular guides).

Type	$\begin{array}{c} n \downarrow \\ m \rightarrow \end{array}$	0	1	2
$TE_{m, n}$	1	1.640	3.414	2.057
	2	0.896	1.178	0.937
	3	0.618	0.736	0.631
$TM_{m, n}$	1	2.619	1.640	1.224
	2	1.139	0.896	0.747
	3	0.726	0.618	0.541

6.1.2.3 Ridged waveguide cutoff wavelength. Ridged guides achieve a greater bandwidth by increasing the spread between the TE_{10} and the TE_{20} modes. Bandwidths as high as 6:1 have been achieved in either single- or double-ridge guides whose cutoff characteristics are approximately

$$\lambda_c = \left(\frac{90^\circ}{\theta_1 + \theta_2} \right) \lambda_{c0}$$

where:

$\lambda_{c0} = 2a =$ cutoff wavelength without ridges

θ_1 and θ_2 satisfy the approximate equation, $\cot \theta_1 + \frac{b_1}{b_2} \cot \theta_2 = 0$

$b_1 =$ inside height of waveguide without ridges

$b_2 =$ inside height of waveguide with ridges

6.1.2.4 Elliptical waveguide cutoff wavelength.^{2/} The cutoff wavelength in elliptical waveguide is determined by the major and minor axis dimensions of the waveguide. For any mode in elliptical waveguide, the cutoff frequency is:

$$\lambda_c = \frac{\pi a e}{\sqrt{q}}$$

where:

$\lambda_c =$ cutoff wavelength

$a =$ major axis of waveguide/2

$e =$ eccentricity of waveguide = $\frac{\sqrt{a^2 - b^2}}{a}$

$b =$ minor axis of waveguide/2

$q =$ modified Mathieu function

The values of q for the modes depicted in Figure 6.3 are tabulated in table 6.II. The values of eccentricity e for which q is valid are also indicated.

^{2/} Wave Propagation in Hollow Conducting Elliptical Waveguide, J.G. Kretzschmar, IEEE Trans, Microwave Theory and Tech., Vol. MTT-18, No. 9, September 1970.

TABLE 6.II. Modified Mathieu function.

Mode	Interval of e	q
eTE ₀₁	(0.45, 1.0)	$q = -1.2264 - 1.393e + 1.5515e^2 + 1.3156/(1-e)$
eTE ₁₁	(0.4, 1.0)	$q = -0.0064e + 0.8838e^2 - 0.0696e^3 + 0.0820e^4$
oTE ₁₁	(0.5, 0.95)	$q = -0.1483 - 1.0821e + 1.0829e^2 + 0.3493/(1-e)$
eTM ₀₁	(0.5, 0.95)	$q = -0.222 - 0.728e + 1.308e^2 + 0.341/(1-e)$
eTM ₁₁	(0.55, 0.95)	$q = -0.1379 - 1.3138e + 3.9307e^2 + 0.4056/(1-e)$
oTM ₁₁	(0.45, 0.95)	$q = -1.2014 - 1.6271e + 2.1684e^2 + 1.3089/(1-e)$

6.1.3 Waveguide wavelength. The wave traveling in a guide in any mode is composed of two component plane wave fronts, each traveling at the speed of light "c" (10⁸ meters per second). As these waves are at an angle to the direction of propagation, the projection of the free wavelength λ , on the guide axis results in a guide wavelength, λ_g , which is always greater. This gives rise to a phase velocity, V_p , which is close to infinite near the cutoff frequency, and approaches the velocity of light as the frequency is increased. The signal or intelligence travels at a velocity less than that of light, known as the group velocity, V_g . These two velocities are related by the expression: $V_p V_g = C^2$. The following relationship applies to any mode in waveguide:

$$\lambda_g = \frac{\lambda}{\sqrt{\epsilon - (\lambda/\lambda_c)^2}}$$

ϵ = relative dielectric constant
($\epsilon = 1$ for an airfilled waveguide)

6.1.4 Waveguide attenuation. As in the coaxial line, the attenuation in a waveguide can be separated into conductor and dielectric losses. For a gaseous-filled guide, the latter may be neglected except at millimeter wavelengths where absorption phenomena may take place at certain frequencies. The conductor or "wall" losses for a given cross section vary as the square root of the resistivity of the material, and the ratio of applied signal wavelength to the cutoff wavelength. As the wavelength is decreased below the cutoff, the attenuation drops rapidly from its very high initial value to a broad minimum and then rises again slowly. This is true for all rectangular and circular waveguide modes, except for the TE_{0n} circular electric modes (i.e., TE₀₁, TE₀₂) whose attenuation continues to decrease with frequency. For minimum attenuation over the largest possible frequency range, the ratio of a/b should be 2.0 in the dominant mode rectangular guide. Theoretical formulas for air-filled rigid rectangular waveguides are given in 6.2. Actual values of attenuation are dependent on microscopic surface conditions as the frequency is increased and the skin depth is reduced to thousandths of an inch. Up to 15 GHz the measured values are generally within 25 percent of the theoretical, with the best correlation being obtained on drawn surfaces. Machined surfaces are frequently poorer and plated surfaces vary a great deal due to porosity and roughness. In the vicinity of 35 GHz, the attenuation can rise from 60 to 110 percent above theoretical and deteriorate even further under adverse environmental conditions. Thin oxides or chemical coatings, even of high resistivity, are not harmful as long as they are good dielectrics.

6.1.5 Waveguide characteristic impedance. Waveguide characteristic impedance may be defined in three ways for a matched lossless rectangular waveguide in the TE₁₀ mode. Similar definitions exist for other types of waveguides:

- $Z_{(w,v)} = V^2/W$, where V is the rms value of the electric voltage at the midpoint of the broad walls, and W is the total power flowing down the guide.
- $Z_{(w,i)} = W/I^2$ where I is the rms value of the longitudinal current flowing on one wall normal to the electric vector, and W is the total power flowing down the guide.
- $Z_{(v,i)} = V/I$, is the geometric mean of $Z_{(w,v)}$ and $Z_{(w,i)}$ above.

MIL-HDBK-216
SECTION 6B
12 June 1975

6.1.5.1 **Wave impedance.** The wave impedance is the ratio of the transverse components of the electric and magnetic field at any point in the waveguide.

$$Z_{\text{wave}} = \frac{V}{I} = \frac{E}{H}$$

For all TE and TM modes the wave impedances for air-filled guides are given by:

$$Z_{\text{TE}} = \eta_0 \frac{\lambda_g}{\lambda} \text{ or } \frac{\eta_0}{\sqrt{1 - (\lambda/\lambda_c)^2}}$$

$$Z_{\text{TM}} = \eta_0 \frac{\lambda}{\lambda_g} \text{ or } \eta_0 \sqrt{1 - (\lambda/\lambda_c)^2}$$

These expressions are useful in the determination of impedance mismatch and voltage standing wave ratio (VSWR) where the guide dimensions are changed slightly without any abrupt discontinuities.

6.1.6 Waveguide power ratings.

6.1.6.1 **Dielectric breakdown power rating.** The power handling capability of a waveguide is determined by the breakdown of the gaseous dielectric in the vicinity of maximum electric stress. The gaseous discharge process is to produce ionizing collisions, the buildup of a positive-ion space charge, and finally the creation of sufficient electrons to permit a gaseous discharge. Whether an electron is effective in starting this process will depend upon its initial position and velocity, and the phase of the microwave field at the time of its appearance. When a single pulse is applied, sufficient time may not exist for breakdown to occur. As the pulse width is decreased below about 1 microsecond at atmospheric pressure, the maximum electric field can be increased significantly. For a series of pulses, the breakdown value is lowered as some electrons will remain from preceding pulses, and eventually a pulse will occur in which breakdown can take place. Thus, the single pulse condition imposes an upper limit and the CW condition a lower limit on the magnitude of the breakdown field. The value for a series of pulses between these would be more variable in a waveguide than a coaxial line due to the nonuniform field distribution, the large gap distances, and the frequency of the applied energy which approaches the transit time of the electrons for the gap spacings involved. Breakdown or continuous discharge occurs when free electrons are produced in the gap at a rate that exceeds their removal by diffusion to the surrounding walls or attachment to neutral gas molecules. This process starts by the chance appearance of a free electron, its acceleration by the electric field limits depending on the pressure and pulse characteristics. It has been shown that the single pulse condition can be used when the repetition rate is less than approximately three times the pressure expressed in millimeters of mercury (normal atmospheric pressure ≈ 760 mm).

Many of the above factors are statistical in their behavior, and in the experimental determination of breakdown, data are usually expressed as a probability of occurrence at a particular power level. Breakdown probability is defined as the ratio of pulses during which breakdown occurs to the total number of pulses applied. This may be projected to a very small but finite probability known as the "onset" stress that determines the rating of waveguide components. Testing time may be reduced by the introduction of a source of energy radiation (X-rays, gamma rays, ultraviolet light, etc) to enhance the production of free electrons beyond that provided by normal background X-ray or cosmic ray radiation. The power handling capabilities of a waveguide can be increased by pressurizing the waveguide or by using a high dielectric strength gas instead of air as a dielectric. Relative breakdown strengths of gases used as waveguide dielectrics are given in table 6.III. Surface toughness or chemical coatings on the waveguide walls will also influence the breakdown value.

TABLE 6.III. Relative breakdown strength of dielectric gases.

Gas	Relative breakdown power <u>1/</u>
Air	1.0
Nitrogen	0.9
Freon 12	18
SF ₆	20
Freon 114	49
Freon C318	60

1/ At one atmosphere pressure absolute.

6.1.6.2 Average (CW) power rating. The recent introduction of very high power radars has led to the establishment of a waveguide average power rating based on the allowable waveguide temperature use due to resistive losses in the waveguide walls. Since waveguide tubing is not a perfect electrical conductor a signal propagating down a waveguide produces a power loss in the waveguide tubing wall. This power loss, in the form of heat, is dissipated to the ambient at a rate that depends upon the physical size and configuration of the waveguide. The average power rating of a waveguide is the power propagating through the waveguide that will produce a specified temperature rise in the waveguide walls for a given ambient temperature condition.

6.1.7 Waveguide construction and materials. A variety of construction techniques and materials are required to encompass the broad range of sizes and frequencies required. In the middle size range drawn tubing of alloys of copper or aluminum are used. The copper alloy known as commercial bronze (90 percent copper, 10 percent zinc) has good mechanical properties, is easy to solder and braze, is reasonably corrosion resistant, and is not subject to failure by seam cracking. Oxygen-free high-conductivity copper (OFHC) and deoxygenized low phosphorous copper (DLP) have increased use since they have a lower initial attenuation and a greater stability than commercial bronze even when the latter is silver plated. For example, the attenuation of WR137 will vary between 1.56 dB per hundred feet for OFHC copper, 2.32 for brass, and 2.00 for aluminum (1100). The drawing process for brass and copper tubing produces smooth non-porous surfaces with an attenuation very close to theoretical up to approximately 10 GHz. Where weight is concerned, aluminum alloy 6061 or aluminum alloy 6063 is used. Both of these alloys exhibit a high strength-to-weight ratio, ready availability, adaptability to various fabrication techniques, and reasonable compromise of electrical characteristics. Aluminum constructions also predominate for sizes above the WR650. It is more economical in these larger sizes to construct the waveguide from various U-shaped sections or flat plates welded together. Where minimum attenuation is required, coin silver (90-percent silver, 10-percent copper) or OFHC copper is used for the WR62 size and smaller. Fine silver plated brass waveguides have found some application in the smaller sizes of waveguide. Problems with increasing attenuation with age due to corrosion of the silver lining have resulted in the increased use of OFHC copper waveguides in the millimeter frequency bands.

6.1.8 Waveguide finishes. Silver plating of brass components is effective in reducing attenuation provided the surfaces are buffed, electropolished, or applied by the "periodic reverse" process to minimize porosity. Plating only affects conductivity when the thickness is at least a few skin thicknesses thick. Unfortunately, some of the silver corrosion products are poor dielectrics and will cause an appreciable increase in losses as the frequency is increased (that is, as the skin depth more nearly approaches the thickness of the corrosion layer). A thin "flash" coating of rhodium, palladium, or gold will minimize the effect of aging. Plating on the interior surfaces of long sections of waveguide tubing should be avoided as normal commercial processes will result in a thin nonuniform coating. While adequate plating thickness can be achieved with internal anodes and a periodic reverse process, it is not economical for

MIL-HDBK-216
SECTION 6B
12 June 1975

long lengths of tubing. When in contact with moist air, aluminum materials develop a thin grey protective film of hydrated oxides that tend to protect them against further corrosion. To reduce galvanic corrosion in the presence of water or other electrolytic solutions, aluminum surfaces are chemically treated in accordance with MIL-C-5541, "Chemical Conversion Coatings on Aluminum and Aluminum Alloys". Exterior surfaces should receive additional coatings of irridite or chromate primers followed by two coats of enamel, in accordance with the procedures outlined in MIL-F-14072, "Finishes for Ground Signal Equipment".

6.2 Rectangular waveguides.

6.2.1 General considerations. Rectangular waveguides are available over the frequency range from 300 MHz to 325 GHz with inside dimensions extending from 23.00 by 11.50 inch to 0.0340 by 0.017 inch. Military procurement is in accordance with MIL-W-85, "Waveguides; Rigid, Rectangular General Specification For", and the requirements therein are closely paralleled by ANSI C83.10-1969, "Rectangular Waveguides (WR3 to WR2300)". The latter includes two series of waveguide sizes. Each series provides a continuous frequency coverage that is displaced in frequency by half of a waveguide band from the other series; that is, the end points of the "A" series are the mid-points of the "B" series. Early waveguides were fabricated from copper or brass architectural tubing whose outside dimensions had a width to height or aspect ratio of 2:1 (i.e., 1 by 1/2 inch, 1/2 by 1/4 inch, etc). These early sizes have been retained, and it is still common practice to refer to waveguide sizes by their outside dimensions. All new guides use an aspect ratio of 2:1 for the inside dimensions that simplifies scaling of designs from one guide size to another. Tables herein summarize the dimensions and frequency range for the EIA standards and those sizes and constructions which have been assigned military nomenclature. The EIA designation consists of the letters WR (waveguide rigid) followed by a number equal to the broad wall dimension in hundredths of an inch. Rectangular waveguides are also supplied in several variations of these dimensions for special applications. Where sections of waveguides are to be used for fabrication of associated devices, precision tubing can be obtained with a maximum tolerance of ± 0.002 inch in any dimension in the RG-49, 50 and 51/U sizes, and with a maximum tolerance of ± 0.001 inch in the RG-52, 91, and 53/U sizes. Where two to three atmospheres of internal pressure are required for high power use, tubing with heavy and extra heavy wall thicknesses is available to limit deformation of the broad wall (see 6.2.6). Where space is at a premium and at low power levels, waveguides with reduced heights are used with some slight increase in attenuation. Thin-wall versions of RG-69/U have also been made in brass and copper-clad stainless steel to reduce weight for long runs on ship-board masts (see 6.2.7).

6.2.2 Rectangular waveguide attenuation above cutoff (TE₁₀ mode).

$$\alpha = \frac{4K}{a} \left[\frac{\sqrt{f}}{\sqrt{1 - \left(\frac{\lambda}{\lambda_c}\right)^2}} \right] \left[\frac{a}{2b} + \left(\frac{\lambda}{\lambda_c}\right)^2 \right]$$

where

- α = attenuation in dB per unit length
- a = inside waveguide width
- b = inside waveguide height
- K = 2.995×10^{-9} for air dielectric and copper waveguide material
(see general equation below for other cases).
- f = frequency of operation in hertz
- λ = free space wavelength
- λ_c = cutoff wavelength

and

$$K = 4.343 \sqrt{\frac{\mu_2 \epsilon_1 \pi}{8\mu_1}}$$

- ϵ_1 = permittivity of air = 8.855×10^{-12} (farad/meter)
 μ_1 = permeability of air = 1.257×10^{-6} (henry/meter)
 μ_2 = magnetic permeability of waveguide metal (henry/meter)
 g = electric conductivity of metal (mho/meter)

Thus, for a given waveguide size, attenuation of a waveguide is inversely proportional to the square root of the metal conductivity.^{1/} (See table 6.IV.)

TABLE 6.IV. Material properties.

Metal composition	Conductivity mho/meter x 10 ⁷	Conductivity % IACS ^{1/}
Silver	6.17	106
Copper		
OF	5.65	101
DLP	5.59	100
Coin silver	4.93	85
Copper alloy (90-10 brass)	2.56	44
Aluminum 1100	3.45	57
Aluminum alloy 6061	2.50	40-45
Aluminum alloy 6063	2.94	50

^{1/} International Annealed Copper Standard

6.2.2.1 Rectangular waveguide attenuation below cutoff (TE₁₀ mode).

$$\alpha = \frac{54.5}{\lambda_c} \sqrt{1 - \left(\frac{\lambda}{\lambda_c}\right)^2}$$

where

- α = attenuation in dB per unit length
 λ = free space wavelength
 λ_c = cutoff wavelength

6.2.3 Rectangular waveguide peak power.^{2/} The peak power capability of a waveguide is determined by the breakdown strength of the waveguide dielectric. For the TE₁₀ mode in a rectangular waveguide, the maximum electric field value occurs at the center of the broad wall. The relationship between the power carried by the waveguide and the maximum rms electric field is:

$$P = 1.33 \times 10^{-3} ab \frac{\lambda}{\lambda_g} E_{rms}^2 \text{ (watts)}$$

- P = power propagating thru waveguide in watts
 a = inner wide dimension of waveguide in meters
 b = inner narrow dimension of waveguide in meters
 λ = operating wavelength in meters
 λ_g = waveguide wavelength in meters
 E_{rms} = RMS breakdown strength of dielectric in volts/meter.

The peak power values in table 6.VI and 6.IX were calculated using this relationship and by assuming that a continuous wave (CW) signal is being propagated down the waveguide. Peak power ratings as a function of pressure are given in figures 6.6 and 6.7.

^{1/} Reference Cox and Rupp, Fight Waveguide Losses 5 Ways, Microwaves, August 1966, pp 32-33.

^{2/} For further reference on peak power calculations see Gould and Gildens Handbook on High Power Capabilities of Waveguide Systems, available from Microwave Associates, Burlington, MA.

MIL-HDBK-216
SECTION 6B
12 June 1975

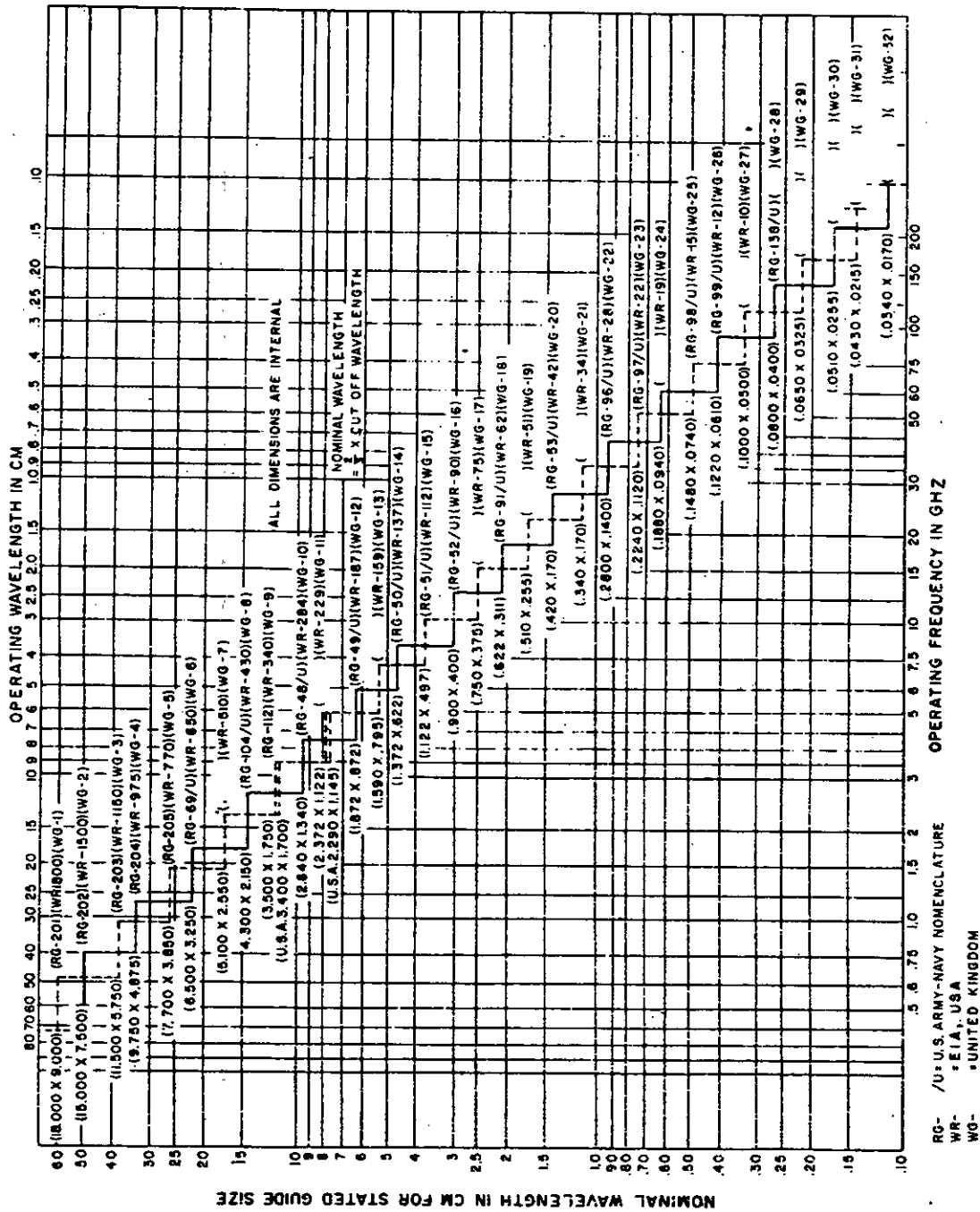

FIGURE 6.4. Operating ranges of serial rectangular waveguides.

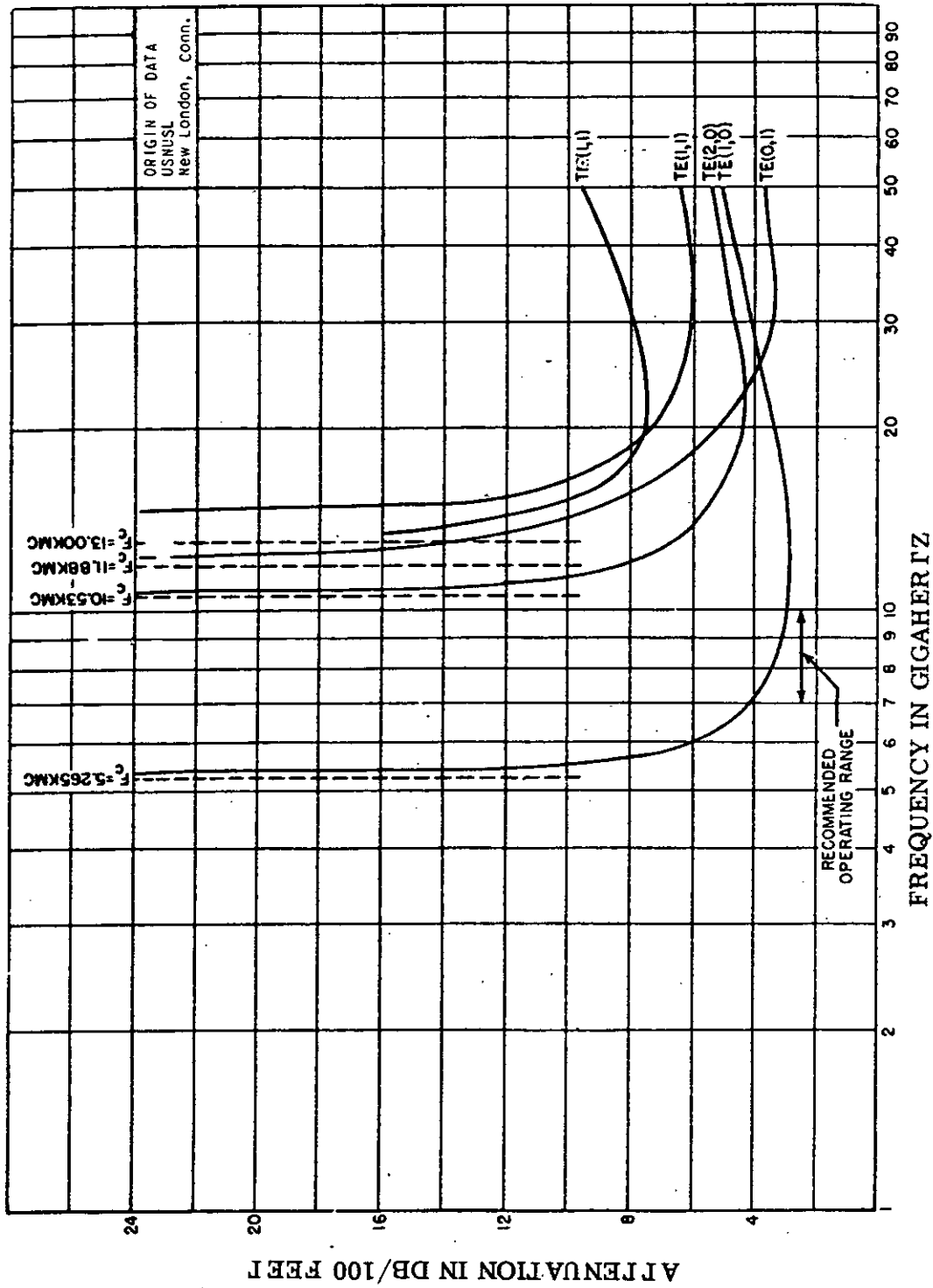

FIGURE 6.5. Attenuation of RG-51/U waveguide.

MIL-HDBK-216
SECTION 6B
12 June 1975

6.2.4 Rectangular waveguide average CW power. The CW power ratings in table 6.VI and 6.IX were calculated by considering the temperature rise in the waveguide produced by resistive losses in the waveguide walls. ^{3/}

$$P \text{ average} = \frac{1.27 q}{\alpha} \text{ watts}$$

where

$$q = q_c + q_r \text{ Btu/hr}$$

and

$$q_c = (\Delta T)^{5/4} \left[\frac{.708 A}{b^{1/4}} + \frac{.717 A}{a^{1/4}} \right] \text{ Btu/hr/ft}$$

$$q_r = 5.19 \times 10^{-10} A_t (T_w^4 - T_a^4) \text{ BTU/hr/ft}$$

P ave = CW power rating of waveguide

q = rate of heat flow from waveguide to ambient

q_c = convection term

q_r = radiation term

α = attenuation of waveguide in dB/ft at the waveguide temperature under consideration

T_w = wall temperature of the waveguide in °R.

T_a = ambient temperature of the waveguide in °R.

ΔT = temperature differential = T_w - T_a in °F.

a¹ = outer wide dimension of the waveguide in feet

b¹ = outer narrow dimension of the waveguides in feet

A_a = the top or bottom area of 1-foot length of waveguide (outer dimensions) in square feet.

A_b = The side or narrow area of 1-foot length of waveguide (outer dimensions) in square feet.

A_t = 2(A_a + A_b) = total outer surface area of 1 foot of waveguide in square feet.

The values in tables 6.VI and 6.IX assume 1:1 VSWR, a waveguide temperature of 71°C, and an ambient temperature of 30°C. To calculate for other situations, see H.E. King.

6.2.5 Standard rectangular waveguide. Tables 6.V through 6.VII describe the standard rectangular waveguides presently specified for military system use.

^{3/} Information on waveguide CW power calculation is from H.E. King, Rectangular Waveguide Theoretical CW Average Power Rating, IRE Transactions PGMTT-9, July 1961, pp 349-357.

TABLE 6.V. Waveguides, rigid, rectangular MIL-W-85/1.

Part number M85/1-	Dimensions (inches) 1/ (nominal)					ASTM type material
	Inside		Outside		Wall	
	Width (A)	Height (B)	Width (C)	Height (D)	Thick- ness	
001-XXX 002-XXX 161-XXX	23.000 (584.20)	11.500 (292.10)	23.376 (593.75)	11.876 (301.65)	.188 (4.78)	1100 6061 6063
003-XXX 004-XXX 162-XXX	21.000 (533.40)	10.500 (266.70)	21.376 (542.95)	10.876 (276.25)	.188 (4.78)	1100 6061 6063
005-XXX 006-XXX 163-XXX	18.000 (457.20)	9.000 (228.60)	18.250 (463.55)	9.250 (234.95)	.125 (3.18)	1100 6061 6063
007-XXX 008-XXX 164-XXX	15.000 (381.00)	7.500 (190.50)	15.250 (387.35)	7.750 (196.85)	.125 (3.18)	1100 6061 6063
009-XXX 010-XXX 165-XXX	11.500 (292.10)	5.750 (146.05)	11.750 (298.45)	6.000 (152.40)	.125 (3.18)	1100 6061 6063
011-XXX 012-XXX 166-XXX	9.750 (247.65)	4.875 (123.83)	10.000 (254.00)	5.125 (130.18)	.125 (3.18)	1100 6061 6063
013-XXX 014-XXX 167-XXX	7.700 (195.58)	3.850 (97.79)	7.950 (201.93)	4.100 (104.14)	.125 (3.18)	1100 6061 6063
015-XXX 017-XXX 018-XXX 019-XXX 168-XXX	6.500 (165.10)	3.250 (82.55)	6.660 (169.16)	3.410 (86.61)	.080 (2.03)	OF - DLP Copper alloy 1100 6061 6063
021-XXX 023-XXX 025-XXX 026-XXX 169-XXX	5.100 (129.54)	2.550 (64.77)	5.260 (133.60)	2.710 (68.83)	.080 (2.03)	OF-DLP Copper alloy 1100 6061 6063
027-XXX 029-XXX 030-XXX 031-XXX 170-XXX	4.300 (109.22)	2.150 (54.61)	4.460 (113.28)	2.310 (58.67)	.080 (2.03)	OF - DLP 1100 6061 Copper alloy 6063
033-XXX 035-XXX 036-XXX 037-XXX 171-XXX	3.400 (86.36)	1.700 (43.18)	3.560 (90.42)	1.860 (47.24)	.080 (2.03)	OF - DLP 1100 6061 Copper alloy 6063

1/ Millimeters are in parentheses.

MIL-HDBK-216
SECTION 6B
12 June 1975

TABLE 6.V. Waveguides rigid, rectangular for MIL-W-85 - Continued.

Part number M85/1-	Dimensions (inches) 1/ (nominal)					ASTM type material
	Inside		Outside		Wall	
	Width (A)	Height (B)	Width (C)	Height (D)	Thick- ness	
039-XXX 041-XXX 042-XXX 043-XXX 172-XXX	2.840 (72.14)	1.340 (34.04)	3.000 (76.20)	1.500 (38.10)	.080 (2.03)	OF - DLP 1100 6061 copper alloy 6063
045-XXX 047-XXX 048-XXX 049-XXX 173-XXX	2.290 (58.17)	1.145 (29.08)	2.418 (61.42)	1.273 (32.33)	.064 (1.63)	OF - DLP 1100 6061 copper alloy 6063
051-XXX 053-XXX 054-XXX 055-XXX 174-XXX	1.872 (47.55)	.872 (22.15)	2.000 (50.80)	1.000 (25.40)	.064 (1.63)	OF - DLP 1100 6061 copper alloy 6063
057-XXX 059-XXX 060-XXX 061-XXX 175-XXX	1.590 (40.39)	.795 (20.19)	1.718 (43.64)	.923 (23.44)	.064 (1.63)	OF - DLP 1100 6061 copper alloy 6063
063-XXX 065-XXX 066-XXX 067-XXX 176-XXX	1.372 (34.85)	.622 (15.80)	1.500 (38.10)	.750 (19.05)	.064 (1.63)	OF - DLP 1100 6061 copper alloy 6063
069-XXX 071-XXX 072-XXX 073-XXX 177-XXX	1.122 (28.50)	.497 (12.62)	1.250 (31.75)	.625 (15.88)	.064 (1.63)	OF - DLP 1100 6061 copper alloy 6063
075-XXX 077-XXX 078-XXX 079-XXX 178-XXX	.900 (22.86)	.400 (10.16)	1.000 (25.40)	.500 (12.70)	.050 (1.27)	OF - DLP 1100 6061 copper alloy 6063
081-XXX 083-XXX 084-XXX 085-XXX 179-XXX	.750 (19.05)	.375 (9.53)	.850 (21.59)	.475 (12.07)	.050 (1.27)	OF - DLP 1100 6061 copper alloy 6063
087-XXX 089-XXX 090-XXX 091-XXX 093-XXX 180-XXX	.622 (15.80)	.311 (7.90)	.702 (17.83)	.391 (9.93)	.040 (1.02)	OF - DLP copper alloy 1100 6061 MIL-S-13282 Grade C 6063

1/ Millimeters are in parentheses.

TABLE 6.V. Waveguides rigid, rectangular for MIL-W-85 - Continued.

Part number M85/1-	Dimensions (inches) ^{1/} (nominal)					ASTM type material
	Inside		Outside		Wall	
	Width (A)	Height (B)	Width (C)	Height (D)	Thick- ness	
094-XXX 096-XXX 097-XXX 098-XXX 181-XXX	.510 (12.95)	.255 (6.48)	.590 (14.99)	.335 (8.51)	.040 (1.02)	OF-DLP copper alloy 1100 6061 6063
100-XXX 102-XXX 103-XXX 104-XXX 106-XXX 182-XXX	.420 (10.67)	.170 (4.32)	.500 (12.70)	.250 (6.35)	.040 (1.02)	OF - DLP copper alloy 1100 6061 MIL-S-13282 Grade C 6063
107-XXX 109-XXX 110-XXX 111-XXX 113-XXX 183-XXX	.340 (8.64)	.170 (4.32)	.420 (10.67)	.250 (6.35)	.040 (1.02)	OF - DLP copper alloy 1100 6061 copper alloy & MIL-S-13282 6063
155-XXX 156-XXX 157-XXX 158-XXX 160-XXX	1.020 (25.91)	.510 (12.95)	1.148 (29.16)	.638 (16.21)	.064 (1.63)	Copper alloy OF - DLP 1100 6061 6063

^{1/} Millimeters are in parentheses.

MIL-HDBK-216
SECTION 6B
12 June 1975

TABLE VI. Engineering information for MIL-W-85/1.

Part number M85/1-	Suggested frequency range TE ₁₀ mode	Cutoff for TE ₁₀ mode	Theoretical 1/ attenuation (lowest to highest frequency)	Theoretical peak power rating 2/ (lowest to highest frequency)	Theoretical CW power rating 3/ (lowest to highest frequency)
	GHz	GHz	dB/100 ft	megawatts	kilowatts
001-XXX	.32 - .49	.256	0.040 - 0.026	528.3 - 753.8	1702 - 2618
002-XXX	.32 - .49	.256	0.047 - 0.031	528.3 - 753.8	1447 - 2194
161-XXX	.32 - .49	.256	0.043 - 0.028	528.3 - 753.8	1582 - 2429
003-XXX	.35 - .53	.281	0.046 - 0.031	439.3 - 625.4	1375 - 2040
004-XXX	.35 - .53	.281	0.054 - 0.036	439.3 - 625.4	1170 - 1756
162-XXX	.35 - .53	.281	0.050 - 0.034	439.3 - 625.4	1264 - 1859
005-XXX	.410 - .625	.328	0.057 - 0.038	325.1 - 461.4	973.0 - 1450
006-XXX	.410 - .625	.328	0.067 - 0.045	325.1 - 461.4	827.2 - 123.2
163-XXX	.410 - .625	.328	0.062 - 0.041	325.1 - 461.4	893.9 - 135.2
007-XXX	.490 - .750	.393	0.076 - 0.051	224.1 - 320.4	630.1 - 939.0
008-XXX	.490 - .750	.393	0.089 - 0.060	224.1 - 320.4	537.7 - 797.6
164-XXX	.490 - .750	.393	0.082 - 0.055	224.1 - 320.4	583.6 - 870.1
009-XXX	.64 - .96	.513	0.113 - 0.076	132.0 - 186.9	342.8 - 509.7
010-XXX	.64 - .96	.513	0.133 - 0.089	132.0 - 186.9	291.0 - 434.9
165-XXX	.64 - .96	.513	0.122 - 0.082	132.0 - 186.9	317.3 - 472.1
011-XXX	.75 - 1.12	.605	0.147 - 0.098	93.81 - 133.7	231.2 - 346.9
012-XXX	.75 - 1.12	.605	0.173 - 0.115	93.81 - 133.7	196.4 - 295.4
166-XXX	.75 - 1.12	.605	0.159 - 0.106	93.81 - 133.7	213.6 - 320.5
013-XXX	.96 - 1.45	.766	0.205 - 0.139	59.67 - 84.18	137.8 - 203.3
014-XXX	.96 - 1.45	.766	0.240 - 0.163	59.67 - 84.18	117.6 - 173.2
167-XXX	.96 - 1.45	.766	0.222 - 0.151	59.67 - 84.18	127.9 - 187.0
015-XXX	1.12 - 1.70	.908	0.213 - 0.141	41.34 - 59.74	114.8 - 173.6
017-XXX	1.12 - 1.70	.908	0.316 - 0.209	41.34 - 59.74	80.53 - 121.8
018-XXX	1.12 - 1.70	.908	0.273 - 0.180	41.34 - 59.74	88.45 - 135.7
019-XXX	1.12 - 1.70	.908	0.320 - 0.212	41.34 - 59.74	76.26 - 115.1
168-XXX	1.12 - 1.170	.908	0.295 - 0.195	41.34 - 59.74	82.72 - 125.1
021-XXX	1.45 - 2.20	1.154	0.296 - 0.201	26.19 - 37.00	68.22 - 100.4
023-XXX	1.45 - 2.20	1.154	0.440 - 0.299	26.19 - 37.00	47.87 - 70.44
025-XXX	1.45 - 2.20	1.154	0.380 - 0.258	26.19 - 37.00	53.19 - 78.34
026-XXX	1.45 - 2.20	1.154	0.446 - 0.303	26.19 - 37.00	45.29 - 66.67
169-XXX	1.45 - 2.20	1.154	0.411 - 0.279	26.19 - 37.00	49.14 - 72.39
027-XXX	1.70 - 2.60	1.375	0.393 - 0.261	18.23 - 26.26	45.14 - 68.00
029-XXX	1.70 - 2.60	1.375	0.502 - 0.334	18.23 - 26.26	35.30 - 53.05
030-XXX	1.70 - 2.60	1.375	0.590 - 0.392	18.23 - 26.26	30.03 - 45.20
031-XXX	1.70 - 2.60	1.375	0.583 - 0.387	18.23 - 26.26	31.67 - 47.71
170-XXX	1.70 - 2.60	1.375	0.544 - 0.361	18.23 - 26.26	32.57 - 49.08
033-XXX	2.20 - 3.30	1.737	0.533 - 0.371	11.87 - 16.44	27.82 - 40.00
035-XXX	2.20 - 3.30	1.737	0.682 - 0.474	11.87 - 16.44	21.73 - 31.26
036-XXX	2.20 - 3.30	1.737	0.801 - 0.557	11.87 - 16.44	18.50 - 26.60
037-XXX	2.20 - 3.30	1.737	0.791 - 0.550	11.87 - 16.44	19.52 - 28.07
171-XXX	2.20 - 3.30	1.737	0.739 - 0.514	11.87 - 16.44	20.05 - 28.83
039-XXX	2.60 - 3.95	2.080	0.742 - 0.508	7.645 - 10.85	17.19 - 25.11
041-XXX	2.60 - 3.95	2.080	0.950 - 0.651	7.645 - 10.85	13.42 - 19.59
042-XXX	2.60 - 3.95	2.080	1.116 - 0.764	7.645 - 10.85	11.42 - 16.69
043-XXX	2.60 - 3.95	2.080	1.102 - 0.754	7.645 - 10.85	12.06 - 17.62
172-XXX	2.60 - 3.95	2.080	1.029 - 0.704	7.645 - 10.85	12.39 - 18.12
045-XXX	3.30 - 4.90	2.577	0.946 - 0.671	7.645 - 10.85	11.52 - 16.23
047-XXX	3.30 - 4.90	2.577	1.211 - 0.858	5.475 - 7.549	8.993 - 12.69
048-XXX	3.30 - 4.90	2.577	1.422 - 1.009	5.475 - 7.549	7.659 - 10.79
049-XXX	3.30 - 4.90	2.577	1.404 - 0.996	5.475 - 7.549	8.083 - 11.39
173-XXX	3.30 - 4.90	2.577	1.311 - 0.930	5.475 - 7.549	8.307 - 11.71

See footnotes at end of table.

TABLE 6.VI. Engineering information for MIL-W-85/1 - Continued.

Part number M85/1-	Suggested frequency range TE ₁₀ mode		Cutoff for TE ₁₀ mode	Theoretical 1/ attenuation (lowest to highest frequency)	Theoretical peak power rating 2/ (lowest to highest frequency)	Theoretical CW power rating 3/ (lowest to highest frequency)	
	GHz					GHz	dB/100 ft
051-XXX	3.95	- 5.85	3.155	1.395 - 0.967	3.296 - 4.697	6.612	- 9.534
053-XXX	3.95	- 5.85	3.155	1.785 - 1.238	3.296 - 4.697	5.165	- 7.446
054-XXX	3.95	- 5.85	3.155	2.097 - 1.454	3.296 - 4.697	4.397	- 6.340
055-XXX	3.95	- 5.85	3.155	2.071 - 1.436	3.296 - 4.697	4.639	- 6.690
174-XXX	3.95	- 5.85	3.155	1.934 - 1.341	3.296 - 4.697	4.767	- 6.874
057-XXX	4.90	- 7.05	3.705	1.553 - 1.160	2.792 - 3.719	5.374	- 7.193
059-XXX	4.90	- 7.05	3.705	1.988 - 1.485	2.792 - 3.719	4.196	- 5.617
060-XXX	4.90	- 7.05	3.705	2.334 - 1.744	2.792 - 3.719	3.574	- 4.783
061-XXX	4.90	- 7.05	3.705	2.305 - 1.722	2.792 - 3.719	3.771	- 5.047
175-XXX	4.90	- 7.05	3.705	2.152 - 1.608	2.792 - 3.719	3.876	- 5.187
063-XXX	5.85	- 8.20	4.285	1.978 - 1.562	1.975 - 2.531	3.708	- 4.695
065-XXX	5.85	- 8.20	4.285	3.532 - 1.999	1.975 - 2.531	2.076	- 3.667
066-XXX	5.85	- 8.20	4.285	4.148 - 2.348	1.975 - 2.531	1.768	- 3.122
067-XXX	5.85	- 8.20	4.285	2.936 - 2.319	1.975 - 2.531	2.602	- 3.294
176-XXX	5.85	- 8.20	4.285	3.824 - 2.164	1.975 - 2.531	1.917	- 3.387
069-XXX	7.05	- 10.00	5.260	2.776 - 2.154	1.284 - 1.702	2.290	- 2.946
071-XXX	7.05	- 10.00	5.260	3.548 - 2.756	1.284 - 1.702	1.788	- 2.301
072-XXX	7.05	- 10.00	5.260	4.166 - 3.238	1.284 - 1.702	1.523	- 1.958
073-XXX	7.05	- 10.00	5.260	4.114 - 3.197	1.284 - 1.702	1.607	- 2.067
177-XXX	7.05	- 10.00	5.260	3.841 - 2.985	1.284 - 1.702	1.652	- 2.124
075-XXX	8.20	- 12.40	6.560	4.328 - 2.995	0.758 - 1.124	1.229	- 1.776
077-XXX	8.20	- 12.40	6.560	5.540 - 3.833	0.758 - 1.124	0.9593	- 1.386
078-XXX	8.20	- 12.40	6.560	6.506 - 4.502	0.758 - 1.124	0.8169	- 1.180
079-XXX	8.20	- 12.40	6.560	6.424 - 4.445	0.758 - 1.124	0.8621	- 1.246
178-XXX	8.20	- 12.40	6.560	5.998 - 4.150	0.758 - 1.124	0.8860	- 1.280
081-XXX	10.00	- 15.00	7.847	5.121 - 3.577	0.622 - 0.903	0.9436	- 1.351
083-XXX	10.00	- 15.00	7.847	6.554 - 4.578	0.622 - 0.903	0.7368	- 1.055
084-XXX	10.00	- 15.00	7.847	7.698 - 5.377	0.622 - 0.903	0.6273	- 0.8982
085-XXX	10.00	- 15.00	7.847	7.601 - 5.309	0.622 - 0.903	0.6621	- 0.9479
179-XXX	10.00	- 15.00	7.847	7.097 - 4.957	0.622 - 0.903	0.6804	- 0.9473
087-XXX	12.40	- 18.00	9.490	6.451 - 4.743	0.457 - 0.633	0.6432	- 0.8749
089-XXX	12.40	- 18.00	9.490	9.578 - 7.041	0.457 - 0.633	0.4513	- 0.6139
090-XXX	12.40	- 18.00	9.490	8.259 - 6.071	0.457 - 0.633	0.5022	- 0.6832
091-XXX	12.40	- 18.00	9.490	9.700 - 7.131	0.457 - 0.633	0.4276	- 0.5816
093-XXX	12.40	- 18.00	9.490	6.910 - 5.079	0.457 - 0.633	0.6016	- 0.8184
180-XXX	12.40	- 18.00	9.490	8.943 - 6.574	0.457 - 0.633	0.4638	- 0.6309
094-XXX	15.00	- 22.00	11.54	8.812 - 6.384	0.312 - 0.433	0.4132	- 0.5701
096-XXX	15.00	- 22.00	11.54	13.08 - 9.477	0.312 - 0.433	0.2899	- 0.4000
097-XXX	15.00	- 22.00	11.54	11.27 - 8.172	0.312 - 0.433	0.3228	- 0.4452
098-XXX	15.00	- 22.00	11.54	13.25 - 9.598	0.312 - 0.433	0.2746	- 0.3791
181-XXX	15.00	- 22.00	11.54	12.21 - 8.849	0.312 - 0.433	0.2979	- 0.4111
100-XXX	18.00	- 26.50	14.080	13.80 - 10.13	0.171 - 0.246	0.2230	- 0.3038
102-XXX	18.00	- 26.50	14.080	20.48 - 15.04	0.171 - 0.246	0.1565	- 0.2132
103-XXX	18.00	- 26.50	14.080	17.66 - 12.97	0.171 - 0.246	0.1742	- 0.2372
104-XXX	18.00	- 26.50	14.080	20.74 - 15.23	0.171 - 0.246	0.1483	- 0.2020
106-XXX	18.00	- 26.50	14.080	14.77 - 10.85	0.171 - 0.246	0.2087	- 0.2842
182-XXX	18.00	- 26.50	14.080	19.12 - 14.04	0.171 - 0.246	0.1609	- 0.2191
107-XXX	22.00	- 33.00	17.28	16.86 - 11.73	0.139 - 0.209	0.1676	- 0.2410
109-XXX	22.00	- 33.00	17.28	25.03 - 17.41	0.139 - 0.209	0.1176	- 0.1691
110-XXX	22.00	- 33.00	17.28	21.58 - 15.01	0.139 - 0.209	0.1309	- 0.1883

See footnotes at end of table.

MIL-HDBK-216
SECTION 6B
12 June 1975

TABLE 6.VI. Engineering information for MIL-W-85/1 - Continued.

Part number M85/1-	Suggested frequency range TE ₁₀ mode	Cutoff for TE ₁₀ mode	Theoretical attenuation (lowest to highest frequency)	Theoretical peak power rating (lowest to highest frequency)	Theoretical CW power rating (lowest to highest frequency)
	GHz	GHz	dB/100 ft	megawatts	kilowatts
111-XXX	22.00 - 33.00	17.28	25.35 - 17.63	0.139 - 0.209	0.1114 - 0.1603
113-XXX	22.00 - 33.00	17.28	16.18 - 11.25	0.139 - 0.209	0.1750 - 0.2517
183-XXX	22.00 - 33.00	17.28	23.37 - 16.26	0.139 - 0.209	0.1209 - 0.1738
155-XXX	7.00 - 11.00	5.780	5.219 - 3.291	1.017 - 1.534	1.220 - 1.935
156-XXX	7.00 - 11.00	5.780	3.516 - 2.217	1.017 - 1.534	1.725 - 2.735
157-XXX	7.00 - 11.00	5.780	4.500 - 2.838	1.017 - 1.534	1.358 - 2.154
158-XXX	7.00 - 11.00	5.780	5.285 - 3.333	1.017 - 1.534	1.156 - 1.834
160-XXX	7.00 - 11.00	5.780	4.873 - 3.073	1.017 - 1.534	1.254 - 1.989

1/ At 20°C waveguide temperature.

2/ These values were determined by calculating the unpressurized air dielectric breakdown strength produced by considering the E field within the waveguide. This determination was based on the peak value of a continuous wave (CW) signal. For further information or to calculate for other situations, see Gould and Gilden's "Handbook of High Power Capabilities of Waveguide Systems" (available from Microwave Associates, Burlington, Massachusetts).

3/ These values were determined by calculation of the rate of heat loss to the ambient, considering a nonpressurized air dielectric waveguide in air using no artificial heat sink. A maximum waveguide temperature of 71°C, 1:1 VSWR, and an ambient temperature of 30°C were assumed. For further information or to calculate for other situations, see H.E. King, "Rectangular Waveguide Theoretical CW Average Power Rating", IRE Transactions PGMTT-9 pp 349-357, July 1961.

TABLE 6.VII. Cross reference and flange information for MIL-W-85/1.

Part number M85/1-	AN type	EIA designation	Flange used with	
			MIL-F-3922/()	UG-()/U
001	RG-290/U	WR2300	1/ ↑ ↓ 1/	---
002	---			---
161	---			---
003	RG-291/U	WR2100		---
004	---			---
162	---			---
005	RG-201/U	WR1800		---
006	---			---
163	---			---
007	RG-202/U	WR1500		---
008	---			---
164	---			---
009	RG-203/U	WR1150		---
010	---			---
165	---			---
011	RG-204/U	WR975		---
012	---			---
166	---		---	
013	RG-205/U	WR770	---	
014	---		---	
167	---		---	
015	---	WR650	58-007, 52-023, 52-001	417B, 1362, 1714
017	RG-69/U		58-007, 52-023, 52-001	417B, 1362, 1714
018	RG103/U		58-008, 52-024, 52-002	418B, 1343, 1720
019	---	WR510	58-008, 52-024, 52-002	418B, 1342, 1720
168	---		58-008, 52-024, 52-002	418B, 1342, 1720
021	---		52-003, 52-025	1715, 1718
023	RG-337/U	WR510	52-003, 52-025	1715, 1718
025	RG338/U		52-004, 52-026	1717, 1719
026	---		52-004, 52-026	1717, 1719
169	---	WR430	52-004, 52-026	1717, 1719
027	---		58-009, 52-027, 52-005	435B, 1344, 1716
029	RG-105/U		58-010, 52-028, 52-006	437B, 1345, 1711
030	---	WR340	58-010, 52-028, 52-006	437B, 1345, 1711
031	RG-104/U		58-009, 52-027, 52-005	435B, 1344, 1716
170	---		58-010, 52-028, 52-006	437B, 1345, 1711
033	---	WR340	58-011, 52-029, 52-007	553A, 1346, 1712
035	RG-113/U		58-012, 52-030, 52-008	554A, 1347, 1713
036	---		58-012, 52-030, 52-008	554A, 1347, 1713
037	RG-112/U	WR284	58-011, 52-029, 52-007	553A, 1346, 1712
171	---		58-012, 52-030, 52-008	554A, 1347, 1713
039	---		56-001, 61-002, 52-031, 64-001, 52-009	53, 54B, 1348, 1479, 1724
041	RG-75/U	WR284	56-002, 61-001, 52-032, 64-002, 52-010	584, 585A, 1349, 1484, 1725
042	---		56-002, 61-001, 52-032, 64-002, 52-010	584, 585A, 1349, 1484, 1725
043	RG-48/U		56-001, 61-002, 52-031, 64-001, 52-009	53, 54B, 1348, 1479, 1724
172	---	WR229	56, 002, 61-001, 52-032 64-002, 52-010	584, 585A, 1349, 1484, 1725
045	---		52-033, 52-011	1350, 1726
047	RG-341/U		52-034, 52-012	1351, 1727
048	---	WR187	52, 034, 52-012	1351, 1727
049	RG-340/U		52-033, 52-011	1350, 1726
173	---		52-034, 52-012	1351, 1727
051	---	62-002, 57-002, 52-035, 63-001, 52-013	148C, 149A, 1352 1475, 1728	

See footnote at end of table.

MIL-HDBK-216
SECTION 6B
12 June 1975

TABLE 6.VII. Cross reference and flange information for MIL-W-85/1 - Continued.

Part number M85/1-	AN type	EIA designation	Flange used with	
			MIL-F-3922/()	UG-()/U
053	RG-95/U	WR187	62-001,57-001,52-036, 63-005,52-014	406B,407,1353, 1480,1729
054	---		62-001,57-001,52-036, 63-005,52-014	406B,407,1353, 1480,1729
055	RG-49/U		62-002,57-002,52-035, 63-001,52-013	148C,149A,1352, 1475,1728
174	---		62-001,57-001,52-036, 63-005,52-014	406B,407,1353, 1480,1729
057	---	WR159	52-037,52-015	1354,1730
059	RG-344/U		52-038,52-016	1355,1731
060	---		52-038,52-016	1355,1731
061	RG-343/U		52-037,52-015	1354,1730
175	---		52-038,52-016	1355,1731
063	---	WR137	60-001,55-001,52-039, 63-002,52-017	343B,344,1356, 1476,1732
065	RG-106/U		60-002,55-002,52-040, 63-006,52-018	440B,441,1357, 1481,1733
066	---		60-002,55-002,52-040, 63-006,52-018	440B,441,1357, 1481,1733
067	RG-50/U		60-001,55-001,52-039, 63-002,52-017	343B,344,1356, 1476,1732
176	---		60-002,55-002,52-040, 63-006,52-018	440B,441,1357, 1481,1733
069	---	WR112	53-002,59-007,52-041, 63-003,52-019	51,52B,1358, 1477,1734
071	RG-68/U		59-009,53-004,52-042, 63-007,52-020	137B,138,1359, 1482,1735
072	---		59-009,53-004,52-042, 63,007,52-020	137B,138,1359, 1482,1735
073	RG-51/U		53-002,59-007,52-041, 63-003,52-019	51,52B,1358, 1477,1734
177	---		59-009,53-004,52-042, 63-007,52-020	137B,138,1359, 1482,1735
075	---	WR90	53-001,59-006,52-043, 63-004,52-021	39,40B,1360, 1478,1736
077	RG-67/U		53-003,59-008,52-044, 63-008,52-022	135,136B,1361, 1483,1737
078	---		53-003,59-008,52-044, 63-008,52-022	135,136B,1361, 1483,1737
079	RG52/U		53-001,59-006,52-043, 63-004,52-021	39,40B,1360, 1478,1736
178	---		53-003,59-008,52-044, 63-008,52-022	135,136B,1361, 1483,1737
081	---	WR75	59-010,53-007	---
083	RG-347/U		59-011,53-008	---
084	---		59-011,53-008	---
085	RG-346/U		59-010,53-007	---
179	---		59-011,53-008	---
087	---	WR62	53-005,59-001	419,541A
089	RG-91/U		53-005,59-001	419,541A
090	RG-349/U		53-006,59-002	1665,1666
091	---		53-006,59-002	1665,1666
093	RG-107/U		53-005,59-001	419,541A
180	---	53-006,59-002	1665,1666	
094	RG-352/U	WR51	69-004,70-010,70-022	---

TABLE 6.VII. Cross reference and flange information for MIL-W-85/1 - Continued.

Part number M85/1-	AN type	EIA designation	Flange used with	
			MIL-F-3922/()	UG-()/U
096	RG-353/U	WR51	1/	---
097	RG-351/U		1/	---
098	---		1/	---
181	---		1/	---
100	---	WR42	54-001,59-003	595,596A
102	RG-53/U		54-001,59-003	595,596A
103	RG-121/U		54-002,59-004	597,598A
104	---		54-002,59-004	597,598A
106	RG-66/U		54-001,59-003	595,596A
182	---		54-002,59-004	597,598A
107	---	WR34	54-004	1530
109	RG-34/U		54-004	1530
110	RG-355/U		1/	---
111	---		1/	---
113	RG-357/U		54-004	1530
183	---		1/	---
155	RG-320/U	WR102	-	1493,1494,1910,1911
156	---		-	1493,1494,1910,1911
157	---		1/	---
158	---		1/	---
160	---		1/	---
			1/	---

1/ No military specifications exist for these flange sizes. Commercial items are available.

6.2.6 Millimeter waveguide tables. Characteristics of waveguides used in the millimeter microwave frequency range are given in tables 6.VII through 6.X.

TABLE 6.VIII. Waveguides, rigid, rectangular (millimeter wavelength) for MIL-W-85/3.

Part number M85/3-	Dimensions (inches) (nominal) 2/				Wall thickness	ASTM type material 1/
	Inside		Outside			
	Width (A)	Height (B)	Width (C)	Height (D)		
006-XXX 007-XXX 008-XXX 009-XXX	.2800 (7.11)	.1400 (3.56)	.360 (9.14)	.220 (5.59)	.040 (1.02)	MIL-S-13282, Grade C OF 3/DLP 6061
010-XXX 011-XXX 012-XXX 013-XXX	.2240 (5.69)	.1120 (2.84)	.304 (7.72)	.192 (4.88)	.040 (1.02)	MIL-S-13282, Grade C OF - DLP 3/ 6061
014-XXX 015-XXX 016-XXX	.1880 (4.78)	.0940 (2.39)	.268 (6.81)	.174 (4.42)	.040 (1.02)	MIL-S-13282, Grade C OF - DLP 3/
017-XXX 018-XXX 019-XXX	.1480 (3.76)	.0740 (1.88)	.228 (5.79)	.154 (3.91)	.040 (1.02)	MIL-S-13282, Grade C OF - DLP 3/

See footnotes at end of table.

MIL-HDBK-216
SECTION 6B
12 June 1975

TABLE 6.VIII. Waveguides, rigid, rectangular (millimeter wavelengths)
for MIL-W-85/3 - Continued.

Part number M85/3-	Dimensions (inches) (nominal) ^{2/}				Wall thickness	ASTM type material ^{1/}
	Inside		Outside			
	Width (A)	Height (B)	Width (C)	Height (D)		
020-XXX 021-XXX 022-XXX	.1220 (3.10)	.0610 (1.55)	.202 (5.13)	.141 (3.58)	.040 (1.02)	MIL-S-13282, Grade C OF - DLP <u>3/</u>
023-XXX 024-XXX 025-XXX	.1000 (2.54)	.0500 (1.27)	.180 (4.57)	.130 (3.30)	.040 (1.02)	MIL-S-13282, Grade C OF - DLP <u>3/</u>
026-XXX 027-XXX 028-XXX	.0800 (2.03)	.0400 (1.02)	.1600 (4.06)	.1200 (3.09)	.040 (1.02)	MIL-S-13282, Grade C OF - DLP <u>3/</u>
029-XXX 030-XXX 031-XXX	.0650 (1.65)	.0325 (.83)	.1450 (3.68)	.1125 (2.86)	.040 (1.02)	MIL-S-13282, Grade C OF - DLP <u>3/</u>
032-XXX 033-XXX 034-XXX	.0510 (1.30)	.0255 (.65)	.1310 (3.33)	.1055 (2.68)	.040 (1.02)	MIL-S-13282, Grade C OF - DLP <u>3/</u>
035-XXX 036-XXX 037-XXX	.0430 (1.09)	.0215 (.55)	.1230 (3.12)	.1015 (2.58)	.040 (1.02)	MIL-S-13282, Grade C OF - DLP <u>3/</u>
038-XXX 039-XXX 040-XXX	.0340 (.86)	.0170 (.43)	.1140 (2.90)	.0970 (2.46)	.040 (1.02)	MIL-S-13282, Grade C OF - DLP <u>3/</u>
041-XXX 042-XXX 043-XXX	.0800 (2.03)	.0400 (1.02)	.120 (3.05)	.080 (2.03)	.020 (.51)	MIL-S-13282, Grade C OF - DLP <u>3/</u>
044-XXX 045-XXX 046-XXX	.0650 (1.65)	.0325 (.83)	.105 (2.67)	.0725 (1.83)	.020 (.51)	MIL-S-13282, Grade C OF - DLP <u>3/</u>
047-XXX 048-XXX 049-XXX	.0510 (1.30)	.0255 (.65)	.091 (2.31)	.0655 (1.65)	.020 (.51)	MIL-S-13282, Grade C OF - DLP <u>3/</u>
050-XXX 051-XXX 052-XXX	.0430 (1.09)	.0215 (.55)	.083 (2.11)	.0615 (1.55)	.020 (.51)	MIL-S-13282, Grade C OF - DLP <u>3/</u>
053-XXX 054-XXX 055-XXX	.0340 (.86)	.0170 (.43)	.074 (1.88)	.057 (1.45)	.020 (.51)	MIL-S-13282, Grade C OF - DLP <u>3/</u>

^{1/} 1100 = aluminum alloy 1100, 6061 - aluminum alloy 6061, 6063 = aluminum alloy 6063, copper alloy = 90-10 brass, OF - DLP = OF or DLP copper, MIL-S-13282 Grade C = coin silver.

^{2/} Millimeters are in parentheses.

^{3/} Material shall be silver (MIL-S-13282, grade A) laminated on copper alloy; minimum thickness .005 inch (.13 mm).

TABLE 6.IX. Engineering information for MIL-W-85/3.

Part number M85/3-	Suggested frequency range TE ₁₀ mode	Cutoff for TE ₁₀ mode	Theoretical 1/ attenuation (lowest to highest frequency)	Theoretical peak power rating 2/ (lowest to highest frequency)	Theoretical CW power rating 3/ (lowest to highest frequency)
	GHz	GHz	dB/100 ft	kilowatts	watts
006-XXX 007-XXX 008-XXX 009-XXX	26.50 - 40.00	21.10	24.55 - 16.80 23.02 - 15.77 21.99 - 15.06 34.46 - 23.59	96.0 - 146	103.1 - 150.1 109.7 - 160.1 115.1 - 168.0 73.27 - 107.0
010-XXX 011-XXX 012-XXX 013-XXX	33.00 - 50.00	26.350	34.57 - 23.50 32.44 - 22.05 30.98 - 21.06 48.53 - 32.99	64.4 - 97.0	64.73 - 95.30 68.89 - 101.4 72.29 - 106.3 46.05 - 67.74
014-XXX 015-XXX 016-XXX	40.00 - 60.00	30.69	42.39 - 30.46 39.81 - 28.60 38.02 - 27.32	48 - 70	48.30 - 67.21 51.32 - 71.43 53.85 - 74.94
017-XXX 018-XXX 019-XXX	50.00 - 75.00	39.90	64.23 - 43.89 60.25 - 41.17 57.55 - 39.32	30 - 40	28.46 - 41.44 30.27 - 44.30 31.76 - 46.49
020-XXX 021-XXX 022-XXX	60.00 - 90.00	48.40	87.79 - 58.86 82.37 - 55.22 78.67 - 52.74	20 - 30	19.15 - 28.56 20.37 - 30.38 21.37 - 31.88
023-XXX 024-XXX 025-XXX	75.00 - 110.00	58.85	112.5 - 79.26 105.6 - 74.37 100.9 - 71.03	14 - 20	13.82 - 19.63 14.73 - 20.86 15.40 - 21.88
026-XXX 027-XXX 028-XXX	90.00 - 140.00	73.84	171.4 - 110.0 160.9 - 103.3 153.7 - 98.67	8.8 - 13	8.618 - 13.43 9.161 - 14.27 9.610 - 14.97
029-XXX 030-XXX 031-XXX	110.00 - 170.00	90.845	238.1 - 150.9 223.5 - 141.7 213.5 - 135.3	5.9 - 9.3	5.662 - 8.934 6.019 - 9.494 6.315 - 9.964
032-XXX 033-XXX 034-XXX	140.00 - 220.00	115.750	343.6 - 216.0 322.7 - 202.8 308.2 - 193.7	3.7 - 6.1	3.674 - 5.844 3.904 - 6.211 4.096 - 6.517
035-XXX 036-XXX 037-XXX	170.00 - 260.00	137.52	428.2 - 283.2 402.0 - 265.9 384.0 - 254.0	2.8 - 4.5	2.832 - 4.282 3.010 - 4.551 3.484 - 4.774
038-XXX 039-XXX 040-XXX	220.00 - 325.00	173.28	570.9 - 388.0 536.0 - 364.4 512.0 - 348.0	1.9 - 2.6	2.021 - 2.973 2.148 - 3.159 2.253 - 3.315
041-XXX 042-XXX 043-XXX	90.00 - 140.00	73.84	171.4 - 110.0 160.9 - 103.3 153.7 - 98.67	8.8 - 13	6.442 - 10.04 6.847 - 10.67 7.183 - 11.19

See footnotes at end of table.

MIL-HDBK-216
SECTION 6B
12 June 1975

TABLE 6.IX. Engineering information for MIL-W-85/3 - Continued.

Part number M85/3-	Suggested frequency range TE ₁₀ mode	Cutoff for TE ₁₀ mode	Theoretical 1/ attenuation (lowest to highest frequency)	Theoretical peak power rating 2/ (lowest to highest frequency)	Theoretical CW power rating 3/ (lowest to highest frequency)
	<u>GHz</u>	<u>GHz</u>	<u>dB/100 ft</u>	<u>kilowatts</u>	<u>watts</u>
044-XXX 045-XXX 046-XXX	110.0 - 170.0	90.845	238.1 - 150.9 223.5 - 141.7 213.5 - 135.3	5.9 - 9.3	4.238 - 6.688 4.506 - 7.107 4.727 - 7.459
047-XXX 048-XXX 049-XXX	140.0 - 220.0	115.750	343.6 - 216.0 322.7 - 202.8 308.2 - 193.7	3.7 - 6.1	2.666 - 4.241 2.833 - 4.507 2.972 - 4.729
050-XXX 051-XXX 052-XXX	170.0 - 260.0	137.52	428.2 - 283.2 402.0 - 265.9 384.0 - 254.0	2.8 - 4.5	2.012 - 3.042 2.139 - 3.233 2.475 - 3.392
053-XXX 054-XXX 055-XXX	220.0 - 325.0	173.28	570.9 - 388.0 536.0 - 364.4 512.1 - 348.0	1.9 - 2.6	1.395 - 2.053 1.483 - 2.181 1.556 - 2.289

1/ At 20°C waveguide temperature.

2/ These values were determined by calculating the unpressurized air dielectric breakdown strength produced by considering the E field within the waveguide. This determination was based on the peak value of a continuous wave (CW) signal. For further information or to calculate for other situations, see Gould and Gilden's "Handbook of High Power Capabilities of Waveguide Systems" (available from Microwave Associates, Burlington, Massachusetts).

3/ These values were determined by calculation of the rate of heat loss to the ambient considering a nonpressurized air dielectric waveguide in air using no artificial heat sink. A maximum waveguide temperature of 71°C, 1:1 VSWR, and an ambient temperature of 30°C were assumed. For further information or to calculate for other situations, see H.E. King, "Rectangular Waveguide Theoretical CW Average Power Rating", IRE Transactions PGMIT-9 pp 349-357, July 1961.

TABLE 6.X. Cross reference and flange information for MIL-W-85/3.

Part number M85/3-	AN type	EIA designation	Flange used with	
			MIL-F-3922/()	UG-()/U
006 007 008 009	RG-96/U --- RG-271/U ---	WR28	54-003, 59-005 54-003, 59-005 54-003, 59-005 1/	599, 600A 599, 600A 599, 600A ---
010 011 012 013	--- RG-97/U RG-272/U ---	WR22	67-001, 65-001 67-001, 65-001 67-001, 65-001 1/	383, 1521 383, 1521 383, 1521 ---
014 015 016	--- --- RG-353/U	WR19	65-002 65-002 65-002	1529 1529 1529
017 018 019	RG-98/U --- RG-273/U	WR15	67-002, 66-002 67-002, 66-002 67-002, 66-002	385, 1523 385, 1523 385, 1523

See footnote at end of table.

TABLE 6.X. Cross reference and flange information
for MIL-W-85/3 - Continued.

Part number M85/3-	AN type	EIA designation	Flange used with	
			MIL-F-3922/()	UG-()/U
020	RG-99/U	WR12	67-003, 66-001	387, 1522
021	---		67-003, 66-001	387, 1522
022	RG-274/U		67-003, 66-001	387, 1522
023	---	WR10	66-007	1528
024	---		66-007	1528
025	RG-359/U		66-007	1528
026	---	WR8	$\frac{1}{1}$	---
027	---		$\frac{1}{1}$	---
028	---		$\frac{1}{1}$	---
029	---	WR6	$\frac{1}{1}$	---
030	---		$\frac{1}{1}$	---
031	---		$\frac{1}{1}$	---
032	---	WR5	$\frac{1}{1}$	---
033	---		$\frac{1}{1}$	---
034	---		$\frac{1}{1}$	---
035	---	WR4	$\frac{1}{1}$	---
036	---		$\frac{1}{1}$	---
037	---		$\frac{1}{1}$	---
038	---	WR3	$\frac{1}{1}$	---
039	---		$\frac{1}{1}$	---
040	---		$\frac{1}{1}$	---
041	---	---	66-006	1527
042	---	---	66-006	1527
043	---	---	66-006	1527
044	---	---	66-004	1525
045	---	---	66-004	1525
046	RG-276/U	---	66-006	1527
047	---	---	66-003	1524
048	---	---	66-003	1524
049	---	---	66-003	1524
050	---	---	66-005	1526
051	---	---	66-005	1526
052	---	---	66-005	1526

1/ No military specifications exist for these flange sizes. Commercial items are available.

MIL-HDBK-216
SECTION 6B
12 June 1975

6.2.7 Heavy wall waveguides. The recent introduction of very high power radars has led to the use of heavier than normal wall thickness waveguide. High power operation usually required that a waveguide be pressurized to high pressures in order to prevent dielectric breakdown (see figures 6.7 and 6.8). A thicker wall is needed to limit deformation under pressure. Tables 6.XI through 6.XIII describe the heavy wall waveguides presently in use in military electronic systems.

TABLE 6.XI. Heavy wall waveguide for MIL-W-85/2.

Part number M85/2-	Dimensions (inches) (nominal)					ASTM type material ^{1/}
	Inside		Outside		Wall thickness	
	Width (A)	Height (B)	Width (C)	Height (D)		
001	2.840	1.340	3.238	1.738	.199	1100
002	2.840	1.340	3.238	1.738	.199	6061
003	1.872	.872	2.172	1.172	.150	1100
004	2.840	1.340	3.238	1.738	.199	6063
005	1.872	.872	2.172	1.172	.150	6063
006	1.872	.872	2.122	1.122	.125	OF - DLP
007	1.122	.497	1.378	.753	.128	OF - DLP
008	.900	.400	1.100	.600	.100	OF - DLP
009	.900	.400	1.300	.800	.200	OF - DLP

^{1/} American Society for Testing and Materials.

TABLE 6.XII. Engineering information for MIL-W-85/2.

Part number M85/2-	Suggested frequency range TE ₁₀ mode	Cutoff for TE ₁₀ mode	Theoretical ^{1/} attenuation (lowest to highest frequency)	Theoretical peak power rating ^{2/} (lowest to highest frequency)	Theoretical CW power rating ^{3/} (lowest to highest frequency)
	GHz	GHz	dB/100 ft	megawatts	kilowatts
001	2.60 - 3.95	2.08	.950 - 0.651	7.645 - 10.85	14.56 - 21.25
002	2.60 - 3.95	2.08	1.116 - 0.764	7.645 - 10.85	12.39 - 18.08
003	3.95 - 5.85	3.155	1.785 - 1.238	3.296 - 4.697	5.637 - 8.127
004	2.60 - 3.95	2.08	1.028 - 0.705	7.645 - 10.85	13.48 - 19.63
005	3.95 - 5.85	3.115	1.933 - 1.340	3.296 - 4.697	5.206 - 7.506
006	3.95 - 5.85	3.115	1.399 - 0.970	3.296 - 4.697	6.961 - 10.05
007	7.05 - 10.0	5.260	2.779 - 2.159	1.284 - 1.702	3.066 - 2.382
008	8.20 - 12.4	6.560	4.339 - 3.003	0.758 - 1.124	4.788 - 3.314
009	8.20 - 12.4	6.560	4.339 - 3.003	0.758 - 1.124	4.788 - 3.314

^{1/} At 20°C waveguide temperature.

^{2/} These values were determined by calculating the unpressurized air dielectric breakdown strength produced by considering the E field within the waveguide. This determination was based on the peak value of a continuous wave (CW) signal. For further information or to calculate for other situations, see Gould and Gilden's "Handbook of High Power Capabilities of Waveguide Systems" (available from Microwave Associates, Burlington, Massachusetts).

^{3/} These values were determined by calculation of the rate of heat loss to the ambient, considering a nonpressurized air dielectric waveguide in air using no artificial heat sink. A maximum waveguide temperature of 71°C, 1:1 VSWR, and an ambient temperature of 30°C were assumed. For further information or to calculate for other situations, see H.E. King, "Rectangular Waveguide Theoretical CW Average Power Rating", IRE transactions PGMT-9 pp 349-357, July 1961.

TABLE 6.XIII. Cross reference and flange information for MIL-W-85/2.

Part number MIL-W-85/2-	AN type	Flange used with	
		MIL-F-3922/() 1/	UG-()/U
001	RG-375/U	56-002, 61-001, 52-032, 64-002, 52-010	584, 585A, 1349, 1484, 1725
002	---	56-002, 61-001, 52-032, 64-002, 52-010	584, 585A, 1349, 1484, 1725
003	---	62-001, 57-001, 52-036, 63-005, 52-014	406B, 407, 1353, 1480, 1729
004	---	56-002, 61-001, 52-032, 64-002, 52-010	584, 585A, 1349, 1484, 1725
005	---	62-001, 57-001, 52-036, 63-005, 52-014	406B, 407, 1353, 1480, 1729
006	---	62-002, 57-002, 52-035, 63-001, 52-013	54B, 149A, 1352, 1475, 1728
007	---	53-002, 59-007, 52-041, 63-003, 52-019	51, 52B, 1358, 1477, 1734
008	---	53-001, 59-006, 52-043, 63-004, 52-021	39, 40B, 1360, 1478, 1736
009	---	53-001, 59-006, 52-043, 63-004, 52-021	39, 40B, 1360, 1478, 1736

1/ Currently MIL-F-3922 flanges are modified to interface with heavy wall waveguides or the ends of heavy wall waveguides are modified to interface with MIL-F-3922 flanges.

6.2.8 Reduced height waveguides. Demands for smaller and lighter waveguides have led to the introduction of reduced height waveguides. These waveguides use the same broad wall dimension as standard waveguides but the narrow wall dimension is reduced, usually by some fraction of the original dimension (for example: 1/2 height waveguide, 1/3 height waveguide, 1/4 height waveguide, etc). This size reduction provides a savings in weight, material, and space requirements with a slight increase in waveguide attenuation and a corresponding decrease in waveguide power handling capability. Tables 6.XIV through 6.XVI describe the special waveguides presently in use in military electronics systems.

TABLE 6.XIV. Reduced height waveguide for MIL-W-85/4.

Part number MIL-W-85/3	Dimensions (inches) (nominal)					ASTM material 1/
	Inside		Outside		Wall thickness	
	Width (A)	Height (B)	Width (C)	Height (D)		
001	2.840	1.004	3.000	1.164	.080	Copper alloy
002	2.840	1.004	3.000	1.164	.080	6061
003	1.372	.487	1.500	.615	.064	Copper alloy
004	1.372	.487	1.500	.615	.064	6061
007	2.840	1.004	3.000	1.164	.080	6063
008	1.372	.487	1.500	.615	.064	6063

1/ American Society for Testing and Materials.

MIL-HDBK-216
SECTION 6B
12 June 1975

TABLE 6.XV. Engineering information for MIL-W-85/4.

Part number MIL-W-85/4	Suggested frequency range TE ₁₀ mode	Cutoff for TE ₁₀ mode	Theoretical ^{1/} attenuation (lowest to highest frequency)	Theoretical peak power rating ^{2/} (lowest to highest frequency)	Theoretical CW power rating ^{3/} (lowest to highest frequency)
	GHz	GHz	dB/100 ft	megawatts	kilowatts
001	2.60 - 5.85	2.080	1.131 - 0.947	5.720 - 8.911	10.25 - 12.24
002	2.60 - 5.85	2.080	1.328 - 0.959	5.720 - 8.911	8.379 - 11.60
003	5.85 - 12.40	4.285	3.399 - 2.819	1.577 - 2.174	1.912 - 2.305
004	5.85 - 12.40	4.285	3.442 - 2.854	1.577 - 2.174	1.812 - 2.185
007	2.60 - 5.85	2.080	1.056 - 0.884	5.720 - 8.911	10.98 - 13.11
008	5.85 - 12.40	4.285	3.174 - 2.665	1.577 - 2.174	2.048 - 2.469

^{1/} At 20°C waveguide temperature.

^{2/} These values were determined by calculating the unpressurized air dielectric breakdown strength produced by considering the E field within the waveguide. This determination was based on the peak value of a continuous wave (CW) signal. For further information or to calculate for other situations, see Gould and Gilden's "Handbook of High Power Capabilities of Waveguide Systems" (available from Microwave Associates, Burlington, Massachusetts).

^{3/} These values were determined by calculation of the rate of heat loss to the ambient, considering a nonpressurized air dielectric waveguide in air using no artificial heat sink. A maximum waveguide temperature of 71°C, 1:1 VSWR, and an ambient temperature of 30°C were assumed. For further information or to calculate for other situations, see H.E. King, "Rectangular Waveguide Theoretical CW Average Power Rating", IRE Transactions PGM-T-9 pp 349-357, July 1961.

TABLE 6.XVI. Cross reference and flange information MIL-W-85/4.

Part number MIL-W-85/4-	AN type	Flange used with	
		MIL-F-3922/()	UG-()U
001	RG-109	---	509, 510, 1905, 1906
002	---	---	---
003	RG-110	---	511, 512, 1908, 1909
004	---	---	---
007	---	---	---
008	---	---	---

6.2.9 Power handling capabilities of rectangular waveguides. Figures 6.6 through 6.9 describe the power handling capabilities of all types of rigid rectangular waveguides. Graphical data is given on waveguide power handling capability vs. waveguide dimensions, and on waveguide power handling capability vs. waveguide pressure.

6.3 Circular waveguides.

6.3.1 General considerations. Circular waveguides have not received the wide usage of rectangular waveguides in the past except as part of rotary joints or transitions that required circular symmetry. Their use is steadily increasing, particularly in light of the greater interest in the higher and higher frequencies. For each mode, the bandwidth is about 30 to 35 percent with recommended limits of operation between 1.15 TE₁₁ to 0.92 TE₂₁, and 1.21 TE₀₁ to 0.91 TE₀₂, respectively. In actual practice the usable bandwidth may be limited to 10 or 15 percent due to the large variation of attenuation with frequency.

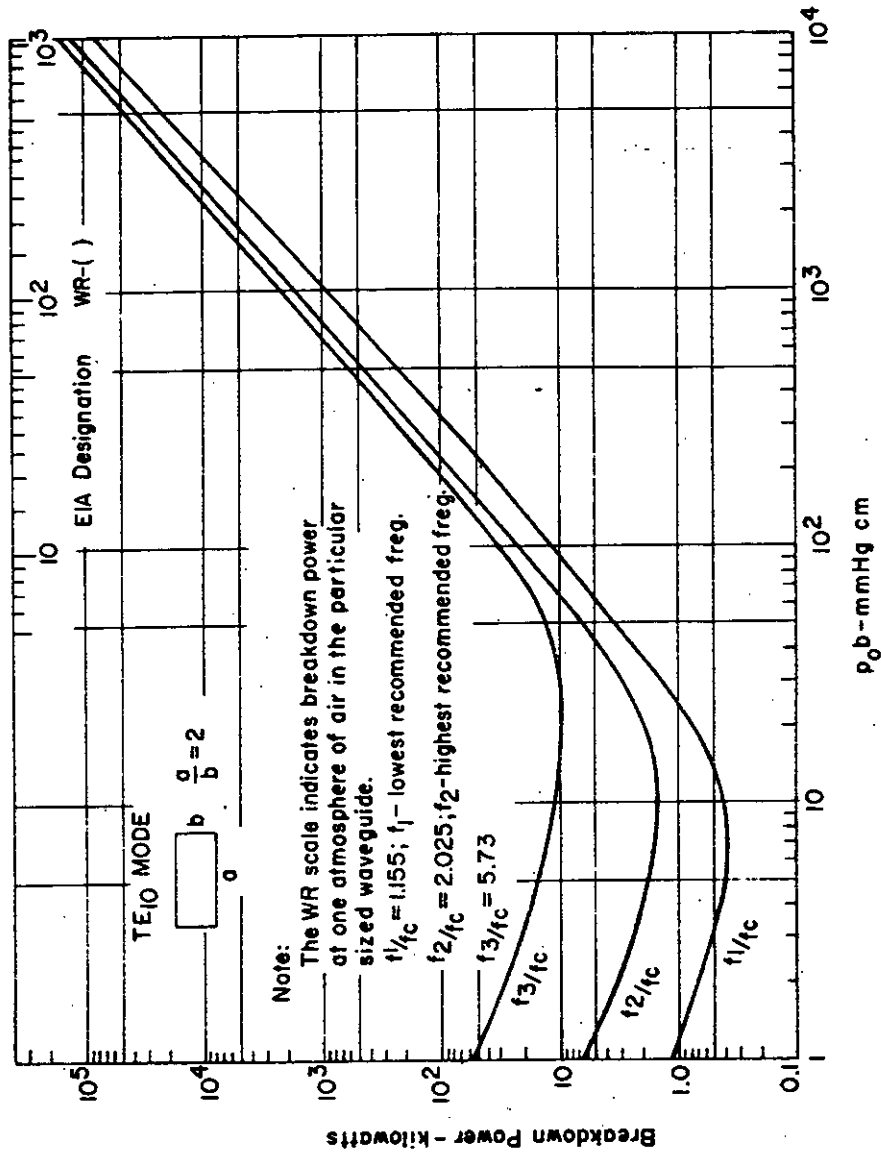

FIGURE 6.6. Breakdown power for air filled standard rectangular waveguides (a/b = 2) (continuous signal).

MIL-HDBK-216
SECTION 6B
12 June 1975

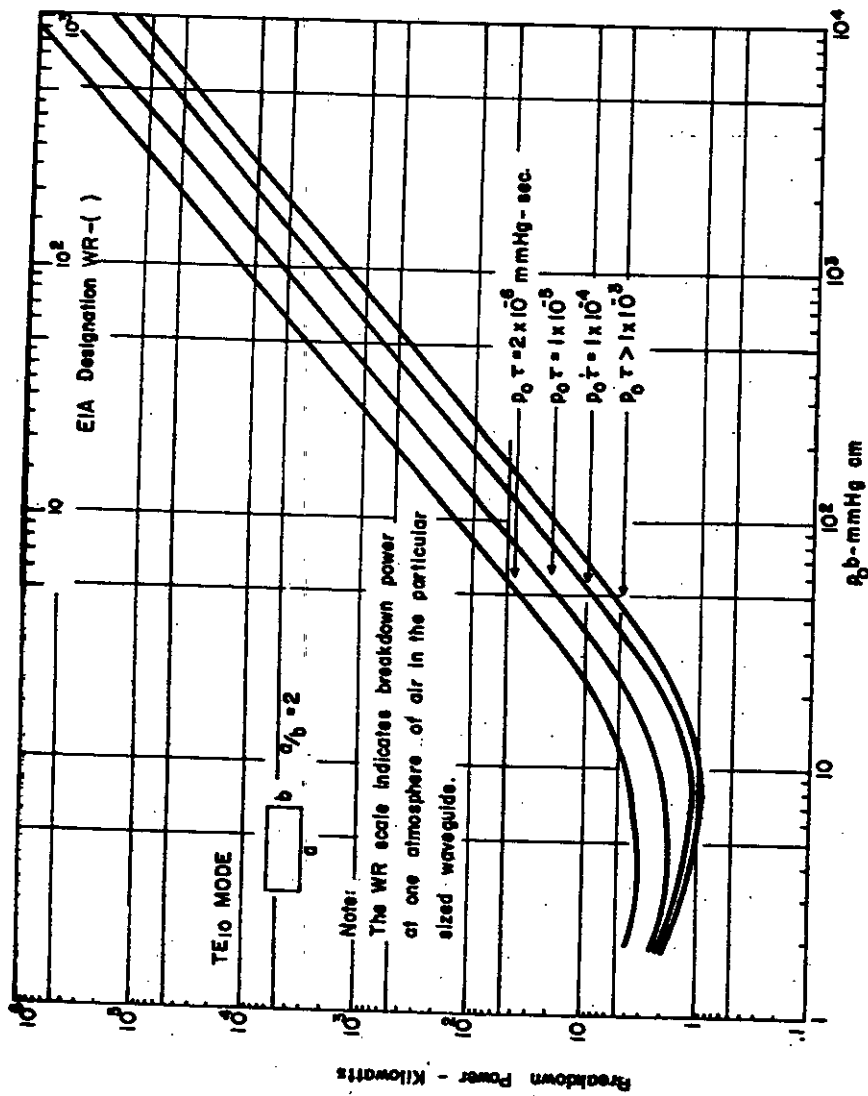

FIGURE 6.7. Single pulse breakdown power for air filled standard waveguides.

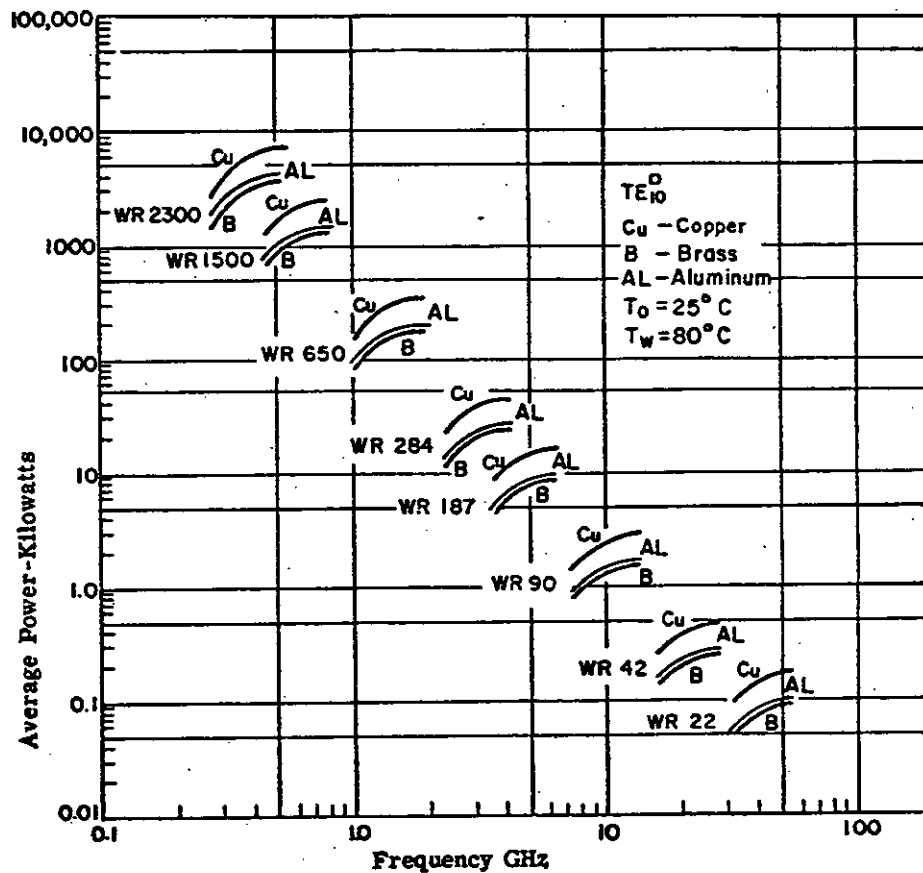

FIGURE 6.8. Average power capability of standard waveguides as a function of frequency.

MIL-HDEK-216
SECTION 6B
12 June 1975

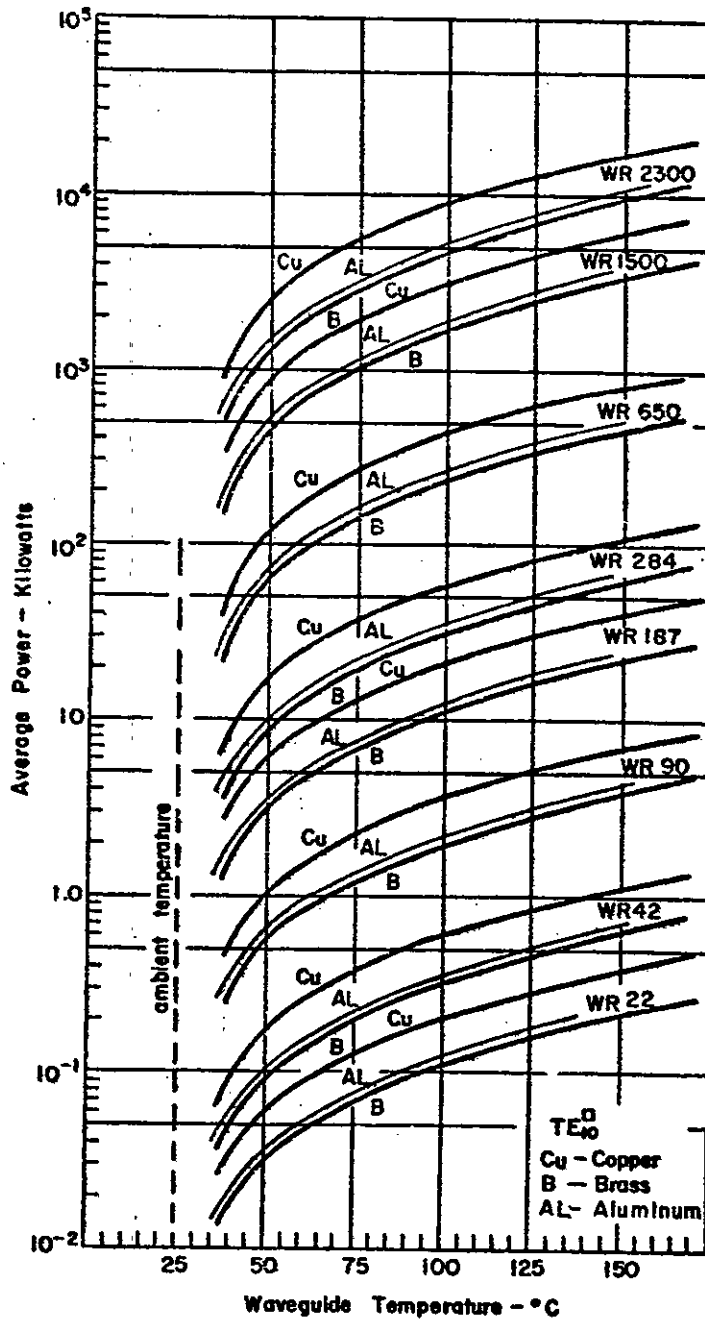

FIGURE 6.9. Average power capability of standard waveguides as a function of waveguide temperature.

6.3.2 Electrical properties. Each mode of operation has particular advantages insofar as the transmission line and the system requirements are concerned.

6.3.2.1 TE₁₁ mode. The TE₁₁ mode in circular waveguide is the dominant mode analogous to the TE₁₀ mode in a rectangular waveguide. The attenuation characteristics vary in a similar manner to that of the rectangular guide. For an equivalent frequency range, the attenuation constant is 61 to 73 percent of rectangular waveguide and the power handling capacity is about 110 percent that of rectangular waveguide. It is possible to propagate simultaneously two independent waves whose direction of polarization are orthogonal in a single circular guide. This property can be put to advantage in the operation of microwave communication relays because a single transmission line can be used to the receiver and transmitter antenna, and in certain components whose operation depends on directional polarization. The extent of mutual coupling between these two waves depends on the degree of ellipticity of the cross section, which must be carefully controlled. Bends and transitions are simpler to fabricate in circular guides operating in the TE₁₁ mode than in the TE₀₁ mode. For the TE₀₁ mode, cutoff wavelength is equal to 1.64 times the inside radius of the waveguide.

6.3.2.2 TE₀₁ mode. The TE₀₁ circular mode has the unique property of an attenuation constant that decreases continuously with increasing frequency. For the same frequency region its mid-band attenuation is 13 to 16 percent of that of a rectangular guide. The TE₀₁ mode power-handling capacity is approximately six times greater than rectangular guide and circular guide in the TE₁₁ mode. For the same frequency coverage, the diameter of the circular waveguide in the TE₁₁ mode must be kept to about half of that of the TE₀₁ mode to eliminate the TE₂₁ mode that is difficult to suppress. Because of these advantages, operation in the TE₀₁ mode becomes increasingly suitable, particularly for the millimeter region where size and dimensional tolerance become critical. Since there is no current flow along the direction of the waveguide axis, connectors, rotary joints, and certain mode absorbers are extremely simple to make. However, any asymmetrical distortions or mechanical imperfections in the waveguide tubing create other modes that do not dampen out as quickly as in the rectangular guide. (The three lower order modes possible are TE₁₁, TM₀₁, and TE₂₁. The TM₁₁ mode is degenerated with, or identical to the TE₀₁ mode.) Inadequate designs for close radius bends for any arbitrary angle still present a major deterrent to the use of the TE₀₁ mode. For very long lengths, however, multimode operation is practical because a large percentage of the energy in all the modes will eventually be coupled back to the TE₀₁ mode. For example, an oversize copper guide can be used which affords dissipative losses of 2 dB per mile under the range of conditions shown in table 6.XVII. The higher frequency is more favorable with regard to increased transmission bandwidth, reduced delay distortion and lower waveguide cost. For the TE₁₁ mode, cutoff wavelength is equal to 3.41 times the inside radius of the waveguide.

TABLE 6.XVII. Characteristics of multimode circular waveguide in TE₀₁ mode.

Carrier frequency (MHz)	Internal dimensions of tubing (inches)	Number of possible modes
5,500	6	20
50,000	2	175

MIL-HDBK-216
SECTION 6B
12 June 1975

6.3.3 Circular waveguide tables.

- (a) Circular waveguides are identified by the three-letter symbol "WRC". The frequency is identified by a three-digit number and a letter. The number identifies the minimum operating frequency in the TE₁₁ mode in megacycles, and the letter identifies the multiplier (see table 6.XVIII). The nominal bandwidth is determined by the two-digit number "14". The number is the nominal bandwidth ratio multiplied by ten. The letter at the end identifies the material listed in table 6.XIX.

TABLE 6.XVIII. Letter multiplier.

Symbol	Multiply by
U	1
D	10
C	100

TABLE 6.XIX. Material.

Symbol	Material
A	Aluminum alloy
B	Brass (copper alloy)
C	Copper
S	Silver alloy (coin silver)

- (b) Circular waveguides used in military systems are listed in tables 6.XX through 6.XXI.

6.3.4 Circular waveguide power handling capabilities. Power handling capabilities of standard circular waveguides are given in figures 6.10 through 6.15.

6.4 Flexible waveguides.

6.4.1 General considerations. Flexible waveguides are used to supplement rigid rectangular or circular waveguides at certain strategic points in a transmission line system. Under no conditions should they be utilized for misalignment purposes or to take up fixed slack in a waveguide run. They are used to:

- (a) Provide expansion and contraction joints in long lines.
- (b) Reduce the transmitted shock and vibration to sensitive devices such as magnetrons.

They are seldom required in long lengths and are customarily procured in finished assemblies with attached flanges. Special flanges and attachment techniques are required for each type of flexible waveguide, together with molded rubber jackets which normally cannot be applied by the user. A general performance specification MIL-W-287, "Waveguide Assemblies, Flexible, Twistable and Nontwistable, General Specification For," is available. There is no universally applicable flexible waveguide but certain constructions are more suitable for specific types of loading as shown in table 6.XXIII. However, the properties of flexible waveguides vary widely according to the metal employed, its thickness and temper, as well as with the composition and contour of the protective jacket. In critical applications the manufacturers should be consulted for their recommendations. Unjacketed flexible waveguides should not be used in locations where sustained exposure to moisture, salt spray, or similar atmospheric contaminants will corrode the metallic joints. Neoprene or natural rubber jackets serve to protect

the seams and improve their overall flexibility. The jacket compound must resist embrittlement and eventual cracking under the deleterious aging effects of sunlight and elevated temperatures. Care should be taken to minimize electrolytic corrosion if copper alloy flexible waveguides are used with aluminum waveguides or vice versa. Plating or chemical treatment of flanges may be required in some environments (see MIL-STD-889 for information on dissimilar metals).

TABLE 6.XX. Dimensions and cross reference for circular waveguides (MIL-W-23068).

Type designation ^{1/}	EIA designation	Dimensions (inches) ^{2/} (nominal)			
		Inside		Outside ^{3/}	Wall thickness
		Diameter			
WRC312U14-	WC2551	25.508	(647.90)
WRC365U14-	WC2179	21.791	(553.49)
WRC427U14-	WC1862	18.616	(472.85)
WRC500U14-	WC1590	15.903	(403.94)
WRC586U14-	WC1359	13.585	(345.06)
WRC686U14-	WC1161	11.606	(294.79)
WRC803U14-	WC 992	9.915	(251.84)
WRC939U14-	WC 847	8.470	(215.14)
WRC110D14-	WC724	7.235	(183.77)
WRC129D14-	WC618	6.181	(157.00)	6.781 (172.24)	0.300 (7.62)
WRC151D14-	WCS28	5.280	(134.11)	5.880 (149.35)	0.300 (7.62)
WRC176D14-	WC451	4.511	(114.58)	5.111 (129.82)	0.300 (7.62)
WRC207D14-	WC385	3.853	(97.87)	4.253 (108.03)	0.200 (5.08)
WRC242D14-	WC329	3.292	(83.67)	3.692 (93.78)	0.200 (5.08)
WRC283D14-	WC281	2.812	(71.43)	3.112 (79.04)	0.150 (3.81)
WRC331D14-	WC240	2.403	(61.04)	2.703 (68.66)	0.150 (3.81)
WRC389D14-	WC205	2.047	(51.99)	2.307 (58.60)	0.130 (3.30)
WRC454D14-	WC175	1.750	(44.45)	2.010 (51.05)	0.130 (3.30)
WRC530D14-	WC150	1.500	(38.10)	1.700 (43.18)	0.100 (2.54)
WRC621D14-	WC128	1.281	(32.54)	1.441 (36.60)	0.080 (2.03)
WRC727D14-	WC109	1.094	(27.79)	1.224 (31.09)	0.065 (1.65)
WRC849D14-	WC 94	0.938	(23.83)	1.068 (27.13)	0.065 (1.65)
WRC997D14-	WC 80	0.797	(20.24)	0.897 (22.78)	0.050 (1.27)
WRC116C14-	WC 69	0.688	(17.48)	0.788 (20.16)	0.050 (1.27)
WRC134C14-	WC 59	0.594	(15.09)	0.674 (17.12)	0.040 (1.02)
WRC159C14-	WC 50	0.500	(12.70)	0.580 (14.73)	0.040 (1.02)
WRC182C14-	WC 44	0.438	(11.13)	0.518 (13.16)	0.040 (1.02)
WRC212C14-	WC 38	0.375	(9.53)	0.435 (11.05)	0.030 (.76)
WRC243C14-	WC 33	0.328	(8.33)	0.388 (9.86)	0.030 (.76)
WRC283C14-	WC 28	0.281	(7.14)	0.341 (8.66)	0.030 (.76)
WRC318C14-	WC 25	0.250	(6.35)	0.290 (7.37)	0.020 (.51)
WRC364C14-	WC 22	0.219	(5.56)	0.259 (6.58)	0.020 (.51)
WRC424C14-	WC 19	0.188	(4.78)	0.228 (5.79)	0.020 (.51)
WRC463C14-	WC 17	0.172	(4.37)	0.212 (5.38)	0.020 (.51)
WRC566C14-	WC 14	0.141	(3.58)	0.181 (4.69)	0.020 (.51)
WRC635C14-	WC 13	0.125	(3.18)	0.155 (3.94)	0.015 (.38)
WRC727C14-	WC 11	0.109	(2.77)	0.139 (3.53)	0.015 (.38)
WRC848C14-	WC 9	0.094	(2.39)	0.124 (3.15)	0.015 (.38)

^{1/} Complete type designation shall include an additional letter symbol to indicate material (see table 6.XXIV).

^{2/} Millimeters are in parentheses.

^{3/} Dimensions on outside diameter and wall thickness are omitted on types WRC312U14- to WRC110D14-, inclusive, because manufacturing methods on these sizes may vary widely, depending on the individual application.

MIL-HDBK-216
SECTION 6B
12 June 1975

TABLE 6.XXI. Frequency ranges and engineering information
for circular, rigid waveguides. (MIL-W-23068)

Type designation ^{1/}	Suggested frequency range		Cutoff frequency for TE ₀₁ mode	Cutoff frequency for TE ₁₁ mode
	TE ₀₁ mode	TE ₁₁ mode		
	GHz	GHz		
WRC312U14-	0.683- 0.940	0.312 - 0.427	.565	.271
WRC365U14-	0.799- 1.100	0.365 - 0.500	.661	.318
WRC427U14-	0.936- 1.290	0.427 - 0.586	.774	.372
WRC500U14-	1.100- 1.510	0.500 - 0.686	.906	.435
WRC586U14-	1.280- 1.770	0.586 - 0.803	1.060	.509
WRC686U14-	1.500- 2.070	0.686 - 0.939	1.241	.596
WRC803U14-	1.760- 2.420	0.803 - 1.100	1.453	.698
WRC939U14-	2.060- 2.830	0.939 - 1.290	1.701	.817
WRC110D14-	2.410- 3.310	1.100 - 1.510	1.991	.957
WRC129D14-	2.820- 3.980	1.290 - 1.760	2.331	1.120
WRC151D14-	3.300- 4.540	1.510 - 2.070	2.729	1.310
WRC176D14-	3.860- 5.320	1.760 - 2.420	3.194	1.530
WRC207D14-	4.520- 6.220	2.070 - 2.830	3.759	1.800
WRC242D14-	5.290- 7.280	2.420 - 3.310	4.376	2.100
WRC283D14-	6.190- 8.530	2.830 - 3.880	5.123	2.460
WRC331D14-	7.250- 9.980	3.310 - 4.540	5.995	2.880
WRC389D14-	8.510- 11.700	3.890 - 5.330	7.038	3.380
WRC454D14-	9.950- 13.700	4.540 - 6.230	8.232	3.960
WRC530D14-	11.600- 16.000	5.300 - 7.270	9.604	4.610
WRC621D14-	13.600- 18.700	6.210 - 8.510	11.246	5.400
WRC727D14-	15.900- 21.900	7.270 - 9.970	13.169	6.330
WRC849D14-	18.600- 25.600	8.490 - 11.600	15.359	7.380
WRC997D14-	21.900- 30.100	9.970 - 13.700	18.076	8.680
WRC116C14-	25.300- 34.900	11.600 - 15.900	20.940	10.100
WRC134C14-	29.300- 40.400	13.400 - 18.400	24.254	11.700
WRC159C14-	34.800- 48.000	15.900 - 21.800	28.813	13.800
WRC182C14-	39.800- 54.800	18.200 - 24.900	32.892	15.800
WRC212C14-	46.400- 63.900	21.200 - 29.100	38.418	18.500
WRC243C14-	53.100- 73.100	24.300 - 33.200	43.923	21.100
WRC283C14-	61.900- 85.200	28.300 - 38.800	51.269	24.600
WRC318C14-	69.700- 95.900	31.800 - 43.600	57.600	27.700
WRC364C14-	79.600- 110.000	36.400 - 49.800	65.800	31.600
WRC424C14-	92.900- 128.000	42.400 - 58.100	76.600	36.800
WRC463C14-	101.000- 139.000	46.300 - 63.500	83.800	40.200
WRC566C14-	124.000- 171.000	56.000 - 77.500	102.000	49.100
WRC635C14-	139.000- 192.000	63.500 - 87.200	115.000	55.400
WRC727C14-	159.000- 219.000	72.700 - 99.700	132.000	63.500
WRC848C14-	186.000- 256.000	84.800 - 116.000	153.000	73.600

1/ Complete type designation shall include an additional letter symbol to indicate material (see table 6.XIX).

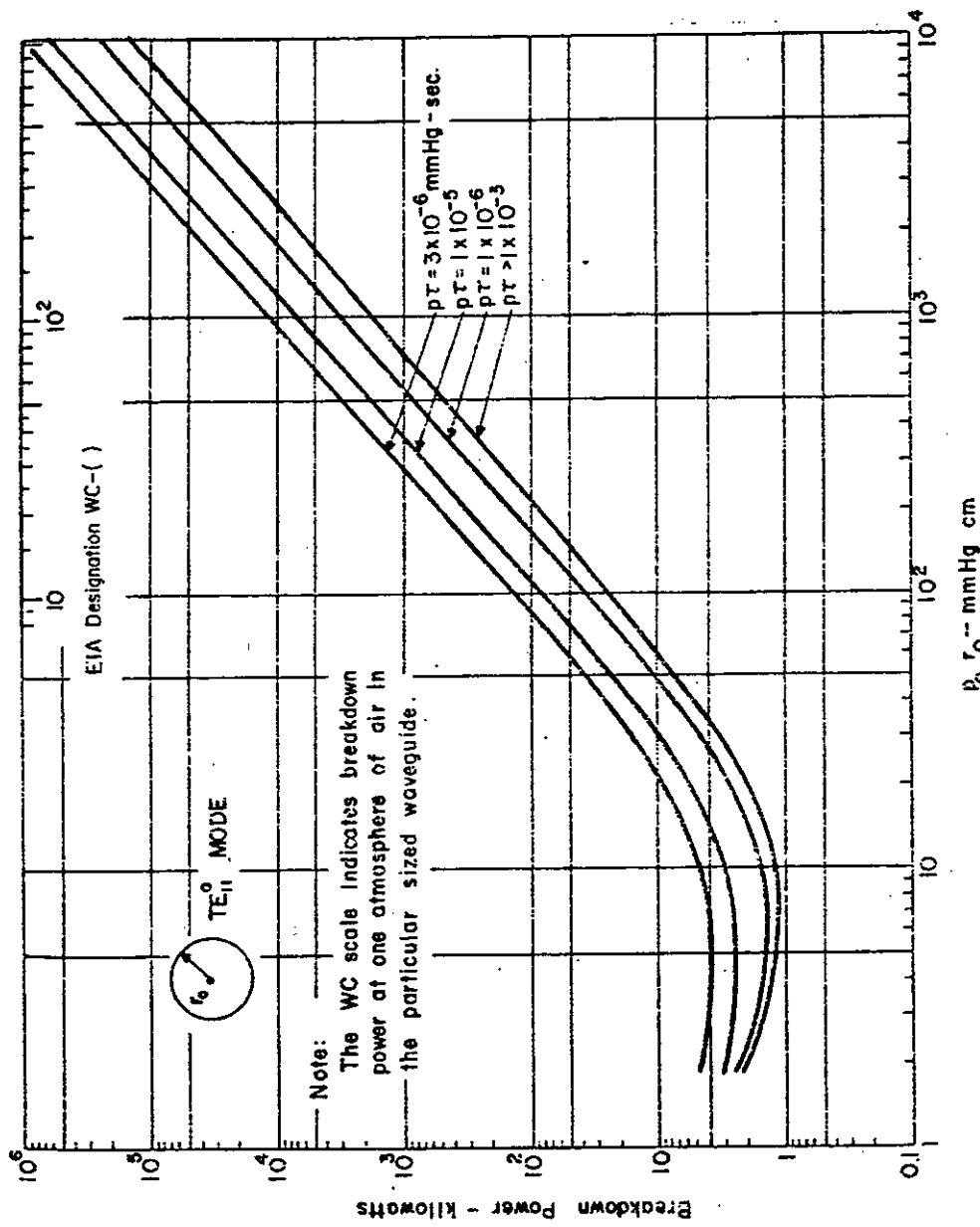

FIGURE 6.10. Single pulse breakdown power for air filled circular waveguides, TE₁₁ mode.

MIL-HDBK-216
SECTION 6B
12 June 1975

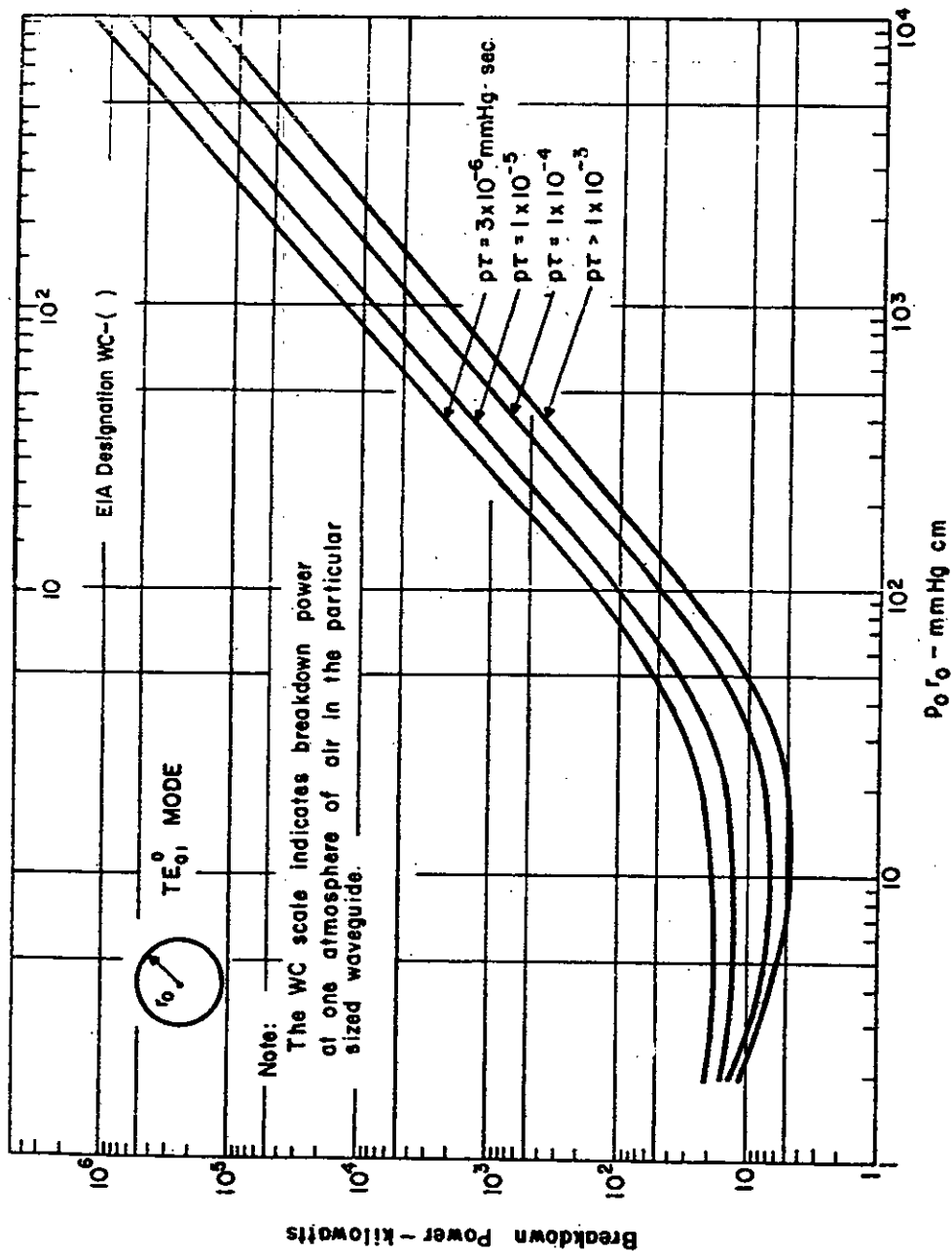

FIGURE 6.11. Single pulse breakdown power for air filled circular waveguides, TE_{01} mode.

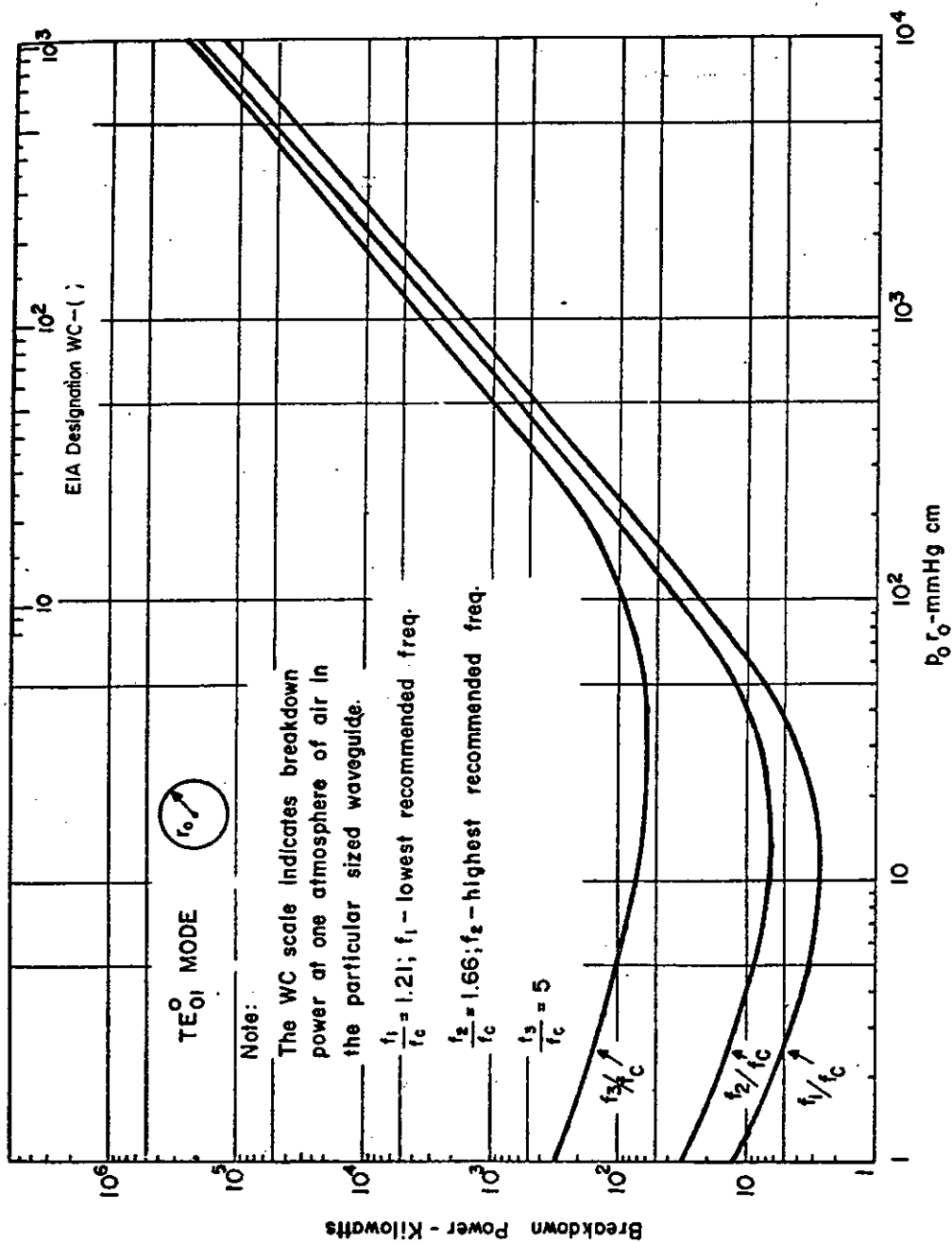

FIGURE 6.12. Breakdown power for air filled circular waveguides TE₀₁ mode (continuous signal).

MIL-HDBK-216
SECTION 68
12 June 1975

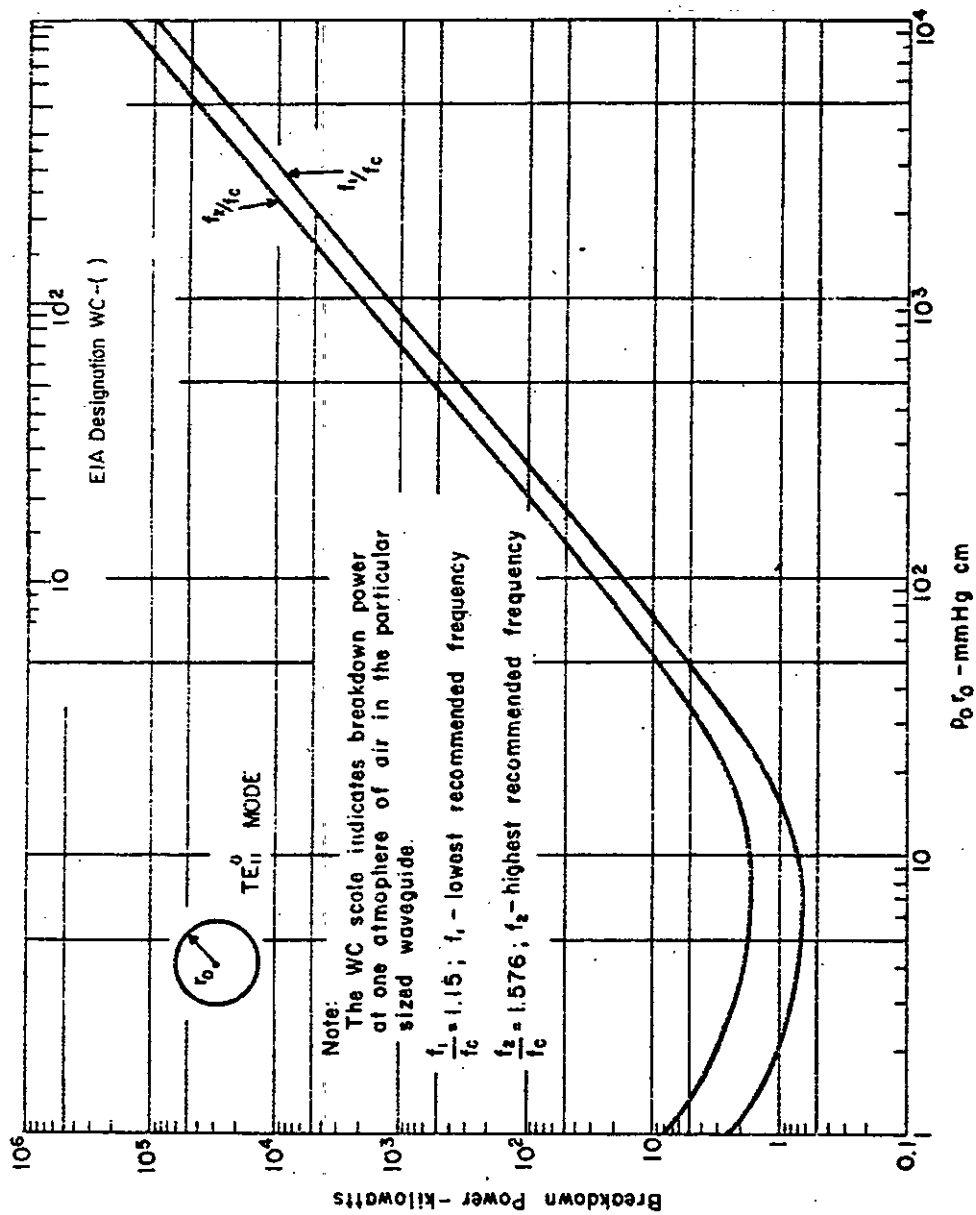

FIGURE 6.13. Breakdown power for air filled circular waveguides, TE₁₁ mode (continuous signal).

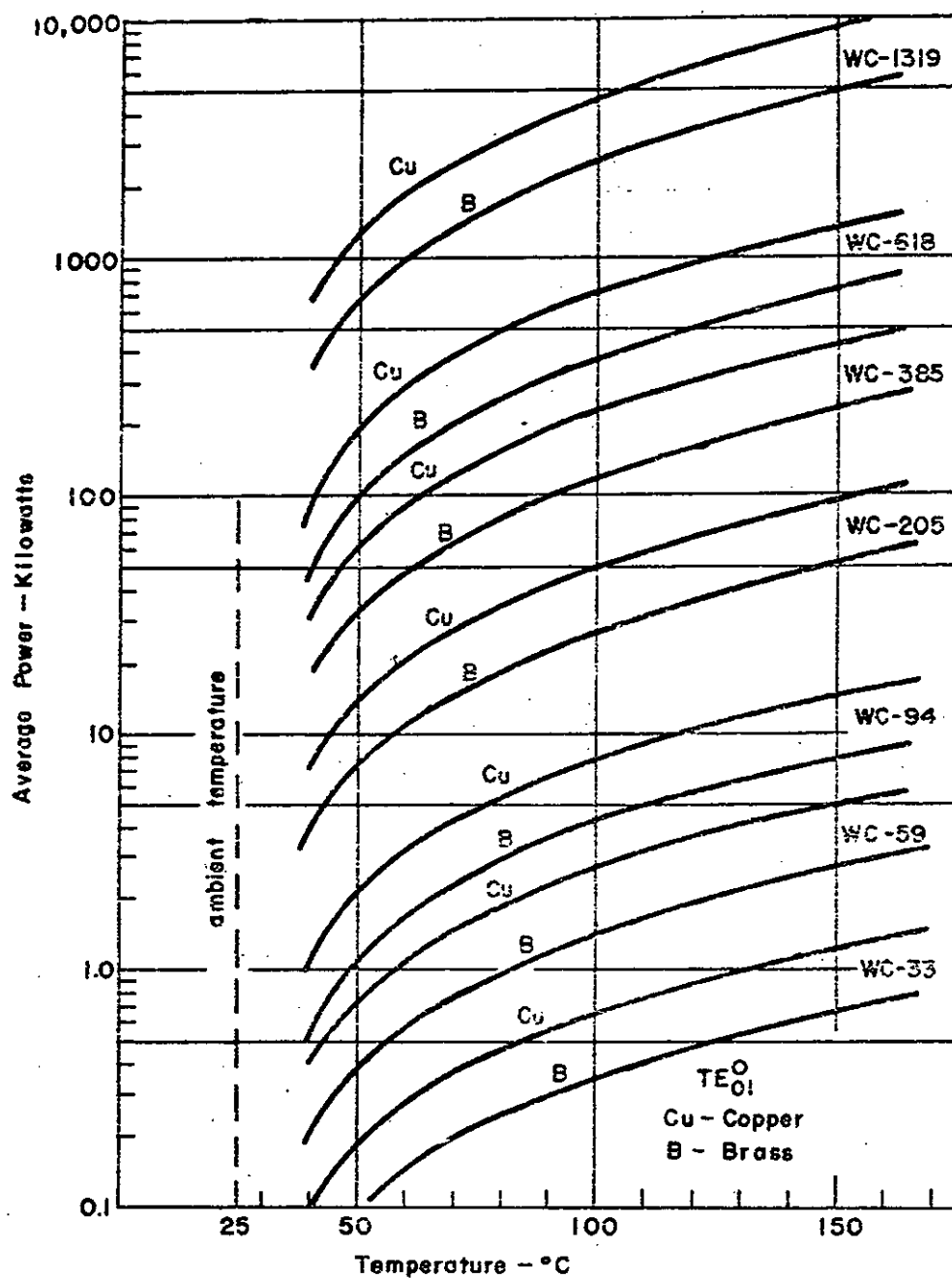

FIGURE 6.14. Average power capability of circular waveguides, TE₀₁ mode, as a function of temperature.

MIL-HDBK-216
SECTION 6B
12 June 1975

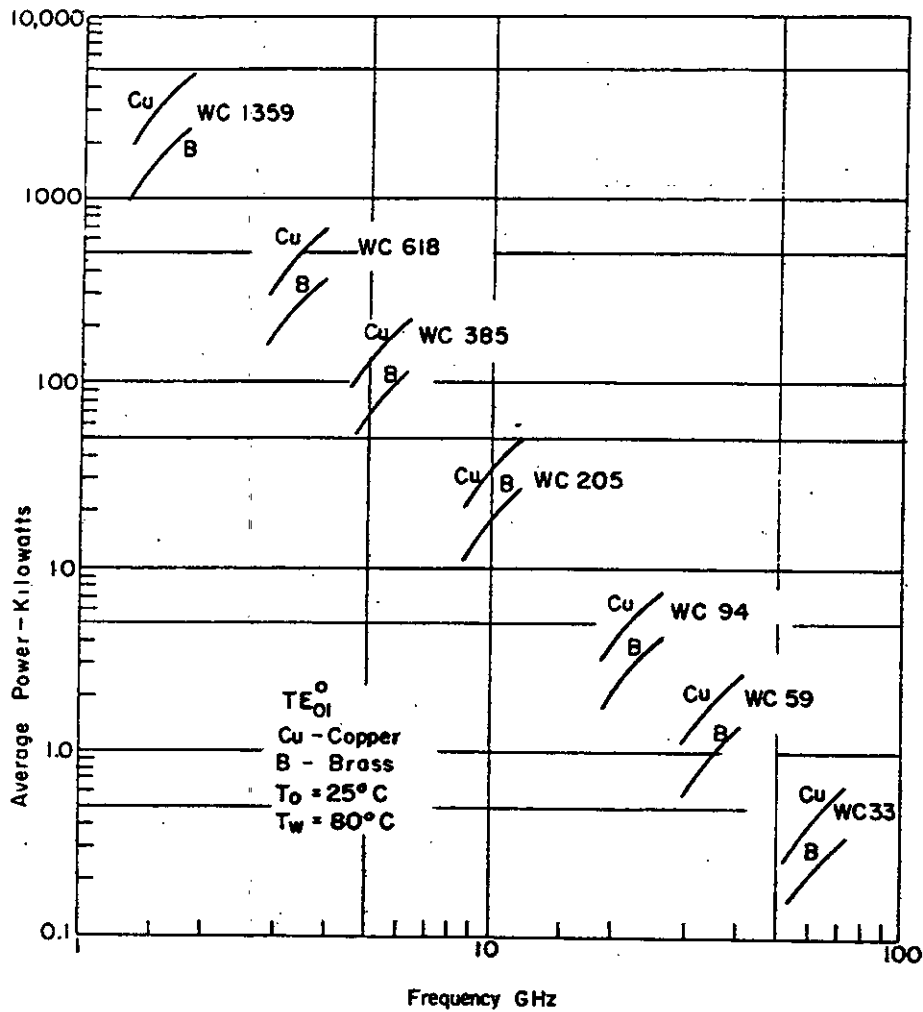

FIGURE 6.15. Average power capability of circular waveguides, TE_{01} mode, as a function of frequency.

6.4.2 Flexible waveguide types. Flexible waveguides may be classed as either resonant or nonresonant types. The nonresonant types are fabricated from spiral wraps (interlocked, soldered convolute, unsoldered convolute) or from thinwall tubing (seamless corrugated or nullpoint seam). The resonant types consist of the bellows or vertebra construction. The significant features of each of these constructions are indicated below and shown in the cutaway sections of figure 6.16 and in table 6.XXIII.

6.4.2.1 Nonresonant types. The internal dimensions of the nonresonant types of flexible waveguides approximate those of the rigid waveguide with which they are intended to mate. Although some adjustments must be made from the irregular contours, the generous corner radii required, and the wall convolutions, a good impedance match with rigid waveguides can generally be achieved. Some reflections are introduced at the couplings, but the VSWR of a relaxed complete assembly can generally be kept below 1.05 over the entire waveguide bandwidth. The VSWR will increase somewhat as the extremes of twisting, shearing, bending, or extension of the flexible elements are approached. As would be expected, the attenuation is considerably higher than that of the rigid waveguide because the corrugations increase the longitudinal conductivity path by two or three times. The power capability of flexible waveguides is at least equal to, and in some cases, exceeds that of rigid waveguides.

6.4.2.1.1 Interlocked. This waveguide is made by spirally winding a thin, formed, silver-coated bronze strip about an arbor, folding in and interlocking the edges tightly to produce a flexible rectangular tubing that has good electrical contact between convolutions. This type of waveguide flexes by virtue of a sliding motion that takes place between convolutions as it is stretched, compressed, bent, or twisted. The formed waveguide is cut to proper lengths and connectors are soldered on. A rubber jacket, molded over the surface of the entire assembly, provides pressurization features, offers considerable protection to the metal tubing, and increases the assembly life for repeated flexings. For special applications a nonjacketed version of this waveguide can be used. This type is particularly useful in lengths from about 6 inches to 4 feet. It is relatively frequency insensitive and has a VSWR below 1.05 for the WR-284 size and below 1.15 for the WR-62 size. It has an attenuation about twice that of rigid silver tubing.

6.4.2.1.2 Soldered convoluted. This waveguide is constructed by winding a very thin metal strip spirally on a rectangular form. Adjacent turns are crimped a small amount and the crimped edges are soft soldered. When this waveguide is flexed there is no sliding of adjacent turns, but a flexing of each individual turn. After winding, the tubing is cut to the required length, connectors are fastened and a rubber jacket molded around it. This waveguide is more flexible than the interlocked waveguide and can be compressed and extended to a greater degree. However, it is more fragile and cannot be twisted to any degree.

6.4.2.1.3 Unsoldered convoluted. This type of construction is similar to the soldered convoluted type except that the crimped edges are not soldered. This waveguide cannot be bent as sharply as the soldered variety but can be twisted. The electrical characteristics are similar to the interlocked and soldered convoluted types.

6.4.2.1.4 Seamless corrugated. This type is constructed by convoluting thin wall, seamless, rectangular metal tubing. It is fabricated from soft annealed copper for use as shock absorbing couplings to fragile components, to magnetrons, for example. It is also made from bronze tubing when a "springy" variety is desired. It can be obtained with or without a rubber jacket. This type will stretch, compress, and bend more than interlocked or convoluted types but cannot withstand any twisting. The electrical properties are good. It is usually supplied in short sections only. A variation of this type is manufactured in the RG-48 and 52/U waveguide sizes. It is formed from two U-shaped halves of silver plated beryllium copper, soldered along the midpoint of the narrow walls. It can withstand relatively sharp bends but negligible twist and extension or compression. Its life under repeated flexing can be greatly improved by annealing the beryllium copper in the desired direction of bend, prior to molding of the rubber jacket.

MIL-HDBK-216
SECTION 6B
12 June 1975

6.4.2.1.5 Null-point seam or axial seam. This type is constructed of a corrugated sheet folded to form a rectangular tube with annular cavities or bellows. The lap seam is located in the center of the larger cross-sectional dimension and is offset to provide a smooth inside contour. The tubing is either bimetallic (silver inner face brazed or welded on a high fatigue resistance alloy base) or silver-plated bronze. The electrical properties are as good as any of the other flexible waveguides. It is available in all lengths and can be obtained with or without a rubber jacket.

6.4.2.2 Resonant types. Resonant types are much more restricted with regard to bandwidth and power capability. The vertebra type is the most versatile mechanically, and has been used widely in medium and small sizes (RG-48 through S3/U). Bandwidth limitations have been overcome on more recent designs. A VSWR of 1.10 or less is possible over a 40-percent frequency band for the vertebra waveguide in the relaxed position. Some typical values of displacement which can be tolerated with significant increase of VSWR are listed in table 6.XXII.

TABLE 6.XXII. Typical displacement values.

Equivalent waveguide size	Extension (inch)	E or H plane shear (inch)	Angular rotation (deg)
RG-48/U	0.600	0.600	21
RG-49/U	0.411	0.411	23
RG-52/U	0.200	0.200	23

6.4.2.2.1 Bellows. The bellows type has been used primarily for narrow-band operation (6 percent) and their power level is limited by the breakdown that occurs across the rectangular openings between the sections. The flexible sections consist of radial chokes made of a flexible alloy forming a bellows. Between radial chokes there is a partition containing a rectangular hole having the dimensions of the inside of the waveguide. Any number of these sections can be stacked together to make a flexible waveguide. This type is quite flexible but cannot be twisted. Resonances which cause large mismatches exist for some critical frequencies when the waveguide is bent or stretched from its normal position.

6.4.2.2.2 Vertebra. This type consists of a number of open choke-cover joints held in alignment and properly spaced by a rubber jacket. Adjacent junctions are spaced approximately 1.4 wavelength apart and generally an even number of such junctions are employed, which make the cancellation of reflections from all junctions possible, thereby keeping the overall VSWR small. For pressurized applications, the rubber jacket is covered with a metal armor. The armor reduces the flexibility but acts as an r-f shield. This waveguide is used in short sections (up to 12 inches) as it is bulky and heavy. It can be extended, compressed bent in both E and H planes, sheared in either plane, or twisted axially at low rates of speed. The static electrical characteristics are maintained under most conditions of mechanical deformation. This waveguide has more degrees of mechanical freedom than any existing waveguide.

6.5 Ridged waveguides.

6.5.1 General considerations. Ridged waveguides achieve broad-band transmission by the addition of a symmetrical ridge from the center of the broad faces of a rectangular guide. Either a single or a double ridge may be used. Performance of both types is very similar, but double-ridged waveguide is preferred for long transmission lines since the depth of ridge is roughly half that of a single ridge. This makes it simpler to hold tolerances on the ridge and to fabricate bends and flexible counterparts. The single-ridged waveguide is more practical for certain components and transitions to coaxial lines.

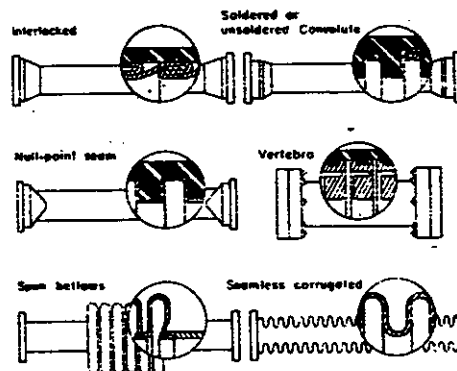

FIGURE 6.16. Flexible waveguide constructions.

MIL-HDBK-216
SECTION 6B
12 June 1975

TABLE 6.XXIII. Mechanical properties of flexible waveguides.

Type of flexible waveguide	Bend		Twist		Longitudinal	
	Relatively sharp	Moderately sharp	Appreciable	Negligible	Relatively large	Relatively small
<u>Nonresonant types</u>	Static deformation					
Interlocked		X	X			X
Unsoldered convolute	X		X			X
Soldered convolute	X			X		X
Null-point seam	X			X		X
Seamless corrugated	X			X	X	
<u>Resonant types</u>						
Vertebra		X	X		X	
Bellows		X			X	
<u>Nonresonant types</u>	Repeated deformation					
Interlocked		X	X			X
Unsoldered convolute	X		X			X
Soldered convolute		X		X		X
Null-point seam		X		X		X
Seamless corrugated		X		X		X
<u>Resonant types</u>						
Vertebra	X		X		X	
Bellows	X			X	X	

6.5.2 General electrical properties. The addition of the ridge lowers the cutoff frequency of the fundamental mode without having as large an effect on the higher modes. There is a wide range of theoretical bandwidths possible because of the almost unlimited number of geometric combinations available. The optimum ratio of ridge to waveguide width (s/a) varies between 0.15 and 0.25 for single ridge, and 0.25 to 0.30 for double ridge for bandwidths up to five. For this s/a ratio, the maximum gap height will result for the desired bandwidth, and the resultant cross section will generally be a compromise between the lowest attenuation and greatest power handling capabilities. The lowered cutoff frequency also permits a more compact cross section and a lower wave impedance structure. Two types of ridged waveguides have been used. The first is of the single-ridge construction with an extremely broad operating frequency range of 4:1. This increased bandwidth is secured at the cost of increased attenuation which is 11.5 times as great as a rectangular waveguide with the same λ_c and aspect ratio. The corners of the ridge are rounded to a minimum radius of $0.1D$ (see figure 6.18a) to prevent electric breakdown at the corners. The CW power capacity is about 2 percent that of standard rectangular waveguide, and the power characteristics are fairly constant over the entire band except near the lower frequencies where λ_g tends to vary rapidly. Despite these limitations, such ridged waveguides and their associated components are advantageous in universal test equipment and for wide-band microwave receivers of the crystal video type. When compared to a rigid air dielectric coaxial line of optimum impedance for minimum attenuation (93 ohms) and for maximum power capacity (44 ohms), the ridge waveguide exhibits better performance for theoretical bandwidths of about 4.0 and 3.0 respectively. However, single ridged waveguides with 2.4:1 and 3.6:1 bandwidths are preferred. Second class is a double ridged waveguide with moderate operating bandwidths of 2.4:1. These are also available with a bandwidth of 3.6:1. By using the lower bandwidth the attenuation and power capabilities are improved considerably and are more compatible with current broad band oscillators and amplifiers.

6.5.3 Construction and finishes. In general, materials, finishes, construction techniques, tolerances, and so on, are basically the same for ridged waveguides as for the rectangular waveguides previously discussed. Tolerance on the gap distance (c) is particularly critical. The connectors used are of the contact type only, but otherwise are very similar to those for the rectangular waveguide. Flexible ridged waveguides are also available in certain sizes with moderate ridge protrusions.

6.5.4 Single and double ridged waveguide figures and tables. Tables 6.XXIV through 6.XXIX and figures 6.17 and 6.18 describe the single and double ridged waveguides presently in use by the military services.

6.6 Elliptical waveguide.

6.6.1 General considerations. Waveguides using an elliptical inside cross section have recently been introduced into military systems. They have been found to be very useful in transmission of high power radar energy for shipboard use.

6.6.2 Mechanical properties. Field formable elliptical waveguide is produced in long continuous lengths (up to 500 feet) from copper or aluminum alloy. The availability of long lengths usually eliminates the need for flanged joints which can cause problems due to flange misalignment and subsequent high VSWR or arcing in a high power system. Most elliptical waveguide in production at this time is either flexible or is field formable using simple bending tools.

6.6.3 Electrical properties. Elliptical waveguides offer lower attenuation (about 70 percent of the attenuation of standard rectangular in the WR-187 size) and slightly higher power handling capabilities than standard rectangular waveguide. These elliptical waveguides operate in the ETE₁₁ mode of propagation. Transitions to standard rectangular waveguide are available.

6.6.4 Elliptical waveguide tables. Elliptical waveguides assigned military nomenclature are described in tables 6.XXX and 6.XXXI, and in figures 6.19 and 6.20.

MIL-HDBK-216
SECTION 6B
12 June 1975

TABLE 6.XXIV. Single ridged waveguides.

Type 1/ designation	Suggested frequency range, GHz	Figure No.	Dimensions (inches) (nominal)							
			A	B	C	D	E	F (max)	G	
MIL-W-23351/3 bandwidth 2.4:1										
WRS175U24-	0.175 - 0.42	6.17a	28.100	12.658	5.278	4.360				1.056
WRS267U24-	0.267 - 0.64	6.17a	18.421	8.289	3.457	2.855				0.691
WRS420U24-	0.42 - 1.0	6.17a	11.695	5.263	2.195	1.613	0.125	0.047		0.439
WRS640U24-	0.64 - 1.53	6.17a	7.682	3.457	1.442	1.191	0.125	0.047		0.288
WRS840U24-	0.84 - 2.0	6.17a	5.847	2.631	1.097	0.906	0.080	0.047		0.219
WRS150D24-	1.5 - 3.6	6.17a	3.276	1.474	0.615	0.508	0.080	0.047		0.123
WRS200D24-	2.0 - 4.8	6.17a	2.456	1.105	0.461	0.381	0.080	0.047		0.092
WRS350D24-	3.5 - 8.2	6.17b	1.404	0.632	0.264	0.218	0.064	0.031		0.053
WRS475D24-	4.75 - 11.0	6.17b	1.034	0.465	0.194	0.160	0.050	0.031		0.039
WRS750D24-	7.5 - 18.0	6.17b	0.655	0.295	0.123	0.1015	0.050	0.015		0.025
WRS110C24-	11.0 - 26.5	6.17b	0.4466	0.2010	0.0838	0.0692	0.040	0.015		0.017
WRS180C24-	18.0 - 40.0	6.17b	0.2729	0.1228	0.0512	0.0423	0.040	0.015		0.010
MIL-W-23351/1 bandwidth 3.6:1										
WRS108U36-	0.108 - 0.39	6.17a	31.218	14.048	2.402	5.307				0.480
WRS270U36-	0.27 - 0.97	6.17a	12.542	5.644	0.965	2.132				0.193
WRS390U36-	0.39 - 1.4	6.17a	8.677	3.905	0.668	1.475	0.125	0.047		0.134
WRS970U36-	0.97 - 3.5	6.17a	3.494	1.572	0.269	0.594	0.080	0.047		0.054
WRS140D36-	1.4 - 5.0	6.17a	2.422	1.090	0.186	0.412	0.080	0.047		0.037
WRS350D36-	3.5 - 12.4	6.17b	0.968	0.436	0.075	0.165	0.050	0.031		0.015
WRS500D36-	5.0 - 18.0	6.17b	0.678	0.305	0.052	0.115	0.050	0.015		0.010
WRS124C36	12.4 - 40.0	6.17b	0.273	0.123	0.021	0.046	0.040	0.015		0.004

1/ Complete type designation will include an additional symbol (A, B, C, or S) to indicate material.

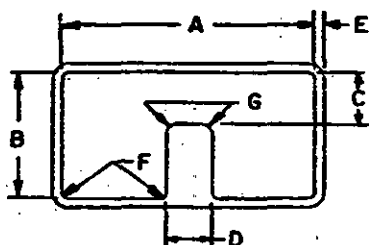

FIGURE 6.17a. Single ridged waveguide cross section.

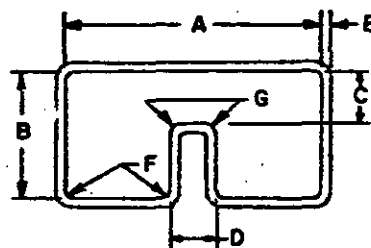

FIGURE 6.17b. Single ridged waveguide cross section.

TABLE 6.XXV. Double ridged waveguides.

Type 1/ designation	Suggested frequency range	Figure No.	Dimensions (inches)						
			A	B	C	D	E	F (max)	G
MIL-W-23351/4 bandwidth 2.4:1									
	GHz								
WRD175U24-	0.175 - 0.42	6.18a	29.667	13.795	5.863	7.417			1.173
WRD267U24-	0.267 - 0.64	6.18a	19.428	0.034	3.839	4.857			0.768
WRD420U24-	0.42 - 1.0	6.18a	12.333	5.737	2.437	3.083	0.125	0.050	0.487
WRD640U24-	0.64 - 1.53	6.18a	8.100	3.767	1.601	2.025	0.125	0.050	0.320
WRD840U24-	0.84 - 2.0	6.18a	6.167	2.868	1.219	1.542	0.125	0.050	0.244
WRD150D24-	1.5 - 3.6	6.18a	3.455	1.607	0.683	0.864	0.080	0.050	0.137
WRD200D24-	2.0 - 4.8	6.18a	2.590	1.205	0.512	0.648	0.080	0.050	0.102
WRD350D24-	3.5 - 8.2	6.18b	1.480	0.688	0.292	0.370	0.064	0.030	0.058
WRD475D24-	4.75 - 11.0	6.18b	1.090	0.506	0.215	0.272	0.050	0.030	0.043
WRD750D24-	7.5 - 18.0	6.18b	0.691	0.321	0.136	0.173	0.050	0.020	0.027
WRD110C24-	11.0 - 26.5	6.18b	0.471	0.219	0.093	0.118	0.040	0.015	0.019
WRD180C24-	18.0 - 40.0	6.18b	0.288	0.134	0.057	0.072	0.040	0.015	0.011
MIL-W-23351/2 bandwidth 3.6:1									
WRD108U36-	0.108 - 0.39	6.18a	34.638	14.894	2.904	8.660			0.581
WRD270U36-	0.27 - 0.97	6.18a	13.916	5.984	1.167	3.479			0.233
WRD390U36-	0.39 - 1.4	6.18a	9.628	4.140	0.807	2.407	0.125	0.050	0.161
WRD970U36-	0.97 - 3.5	6.18a	3.877	1.667	0.325	0.969	0.080	0.050	0.065
WRD140D36-	1.4 - 5.0	6.18a	2.687	1.155	0.225	0.672	0.080	0.050	0.045
WRD350D36-	3.5 - 12.4	6.18b	1.074	0.462	0.090	0.269	0.050	0.030	0.018
WRD500D36-	5.0 - 18.0	6.18b	0.752	0.323	0.063	0.188	0.050	0.020	0.013
WRD124C36-	12.4 - 40.0	6.18b	0.303	0.130	0.025	0.076	0.040	0.015	0.005

1/ Complete type designation will include an additional symbol (A, B, C, or S) to indicate material.

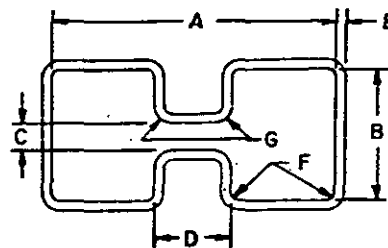
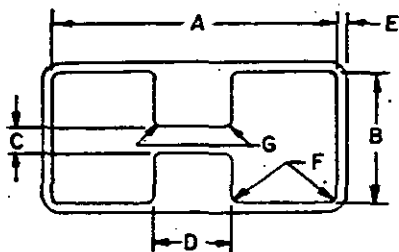

FIGURE 6.18a. Double ridged waveguide cross section. FIGURE 6.18b. Double ridged waveguide cross section.

MIL-HDBK-216
SECTION 6B
12 June 1975

TABLE 6.XXVI. Single-ridged waveguides, bandwidth ratio 2.4:1 (MIL-W-23351).

Type 1/ designation	Cutoff for TH ₁₀ mode GHZ 0.148	Cutoff for TH ₂₀ mode GHZ 0.431	Recommended frequency range TH ₁₀ mode GHZ 0.175-0.420	Material	Flange used with		f =	
					MIL-F-39000/()	UG-()/U	Theoretical attenuation 3/ decibels/foot	Peak power rating 4/ kilowatts
WRS175U24-				Aluminum alloy Brass Copper Silver alloy	---	---	0.00036 0.00036 0.00024 0.00026	32,870
WRS267U24-	0.0226	0.658	0.267-0.640	Aluminum alloy Brass Copper Silver alloy	---	---	0.00068 0.00067 0.00045 0.00048	14,100
WRS420U24-	0.356	1.036	0.420-1.000	Aluminum alloy Brass Copper Silver alloy	---	---	0.00130 0.00129 0.00087 0.00093	5,682
WRS640U24-	0.542	1.577	0.640-1.530	Aluminum alloy Brass Copper Silver alloy	---	---	0.00247 0.00243 0.00164 0.00176	2,451
WRS840U24-	0.712	2.072	0.840-2.000	Aluminum alloy Brass Copper Silver alloy	1-001 1-002 1-002 1-002	1541 1542 1542 1542	0.00373 0.00368 0.00248 0.00266	1,421
WRS150D24-	1.271	3.699	1.500-3.600	Aluminum alloy Brass Copper Silver alloy	1-004 1-005 1-005 1-005	1544 1545 1545 1545	0.00888 0.00877 0.00591 0.00633	445.8
WRS200D24-	1.695	4.933	2.000-4.800	Aluminum alloy Brass Copper Silver alloy	1-007 1-008 1-008 1-008	1547 1548 1548 1548	0.0136 0.0135 0.00908 0.00972	250.6

See footnotes at end of table.

TABLE 6.XXVI. Single-ridged waveguides, bandwidth ratio 2.4:1 (MIL-W-23351) -Continued.

Type 1/ designation	Cutoff for TE ₁₀ mode	Cutoff for TE ₂₀ mode	Recommended frequency range TE ₁₀ mode	Material	Flange used with		f =												
					MIL-F-39000/()	UG-()/U	Theoretical attenuation 3/ decibels/foot	Peak power rating 4/ kilowatts											
WRS350D24-	GHZ 2.966	GHZ 8.632	GHZ 3.500-8.200	Aluminum alloy Brass Copper Silver alloy		1-010 1-011 1-011 1-011	1550 1551 1551 1551	0.0319 0.0315 0.0212 0.0227	81.87										
										Aluminum alloy Brass Copper Silver alloy	1-013 1-014 1-014 1-014	1553 1554 1554 1554	0.0501 0.0494 0.0333 0.0357	44.43					
															Aluminum alloy Brass Copper Silver alloy	1-016 1-017 1-017 1-017	1556 1557 1557 1557	0.0994 0.0981 0.0661 0.0708	17.82
Aluminum alloy Brass Copper Silver alloy	1-022 1-023 1-023 1-023	1562 1563 1563 1563	0.370 0.365 0.246 0.263	3.095															
					Aluminum alloy Brass Copper Silver alloy	1-022 1-023 1-023 1-023	1562 1563 1563 1563	0.370 0.365 0.246 0.263	3.095										

1/ Complete type designation will include an additional symbol (A, B, C, or S) to indicate material.

2/ f_c = cutoff frequency for TE₁₀ mode.

3/ Typical resistivities of materials (at 20°C): Aluminum alloy (6061) = 4.00 microhm-cm; Brass = 3.9 microhm-cm; Copper = 1.77 microhm-cm; Silver alloy (coin silver) = 2.03 microhm-cm.

4/ Based on the E field produced breakdown in a nonpressurized air dielectric waveguide under continuous wave (cw) conditions. The breakdown strength of air was considered to be 15,000 volts per centimeter, corner radii considered.

MIL-HDBK-216
SECTION 6B
12 June 1975

MIL-HDBK-216
SECTION 6B
12 June 1975

TABLE 6.XXVII. Single-ridged waveguides, bandwidth ratio 3.6:1 (MIL-W-23351).

Type 1/ designation	Cutoff for TE ₁₀ mode	Cutoff for TE ₂₀ mode	Recommended frequency range TE ₁₀ mode	Material	Flange used with		f = $\sqrt{3} f_{c10} \frac{2}{1}$	
					MIL-F-39000/()	UG-()/U	Theoretical attenuation 3/ decibels/foot	Peak power rating 4/ kilowatts
WRS108U36-	GHZ 0.092	GHZ 0.404	GHZ 0.108-0.390	Aluminum alloy Brass Copper Silver alloy	---	---	0.0024 0.0024 0.0016 0.0017	14,550
WRS270U36-	0.229	1.006	0.270-0.970	Aluminum alloy Brass Copper Silver alloy	---	---	0.0098 0.0096 0.0065 0.0070	2,348
WRS390U36-	0.331	1.454	0.390-1.400	Aluminum alloy Brass Copper Silver alloy	---	---	0.0168 0.0166 0.0112 0.0120	1,124
WRS970U36-	0.822	3.611	0.970-3.500	Aluminum alloy Brass Copper Silver alloy	2-001 2-002 2-002	1604 1605 1605	0.0658 0.0650 0.0438 0.0469	182.2
WRS140D36-	1.186	5.210	1.40-5.00	Aluminum alloy Brass Copper Silver alloy	2-004 2-005 2-005 2-005	1607 1608 1608 1608	0.114 0.113 0.0758 0.0812	87.56
WRS350D36-	2.966	13.030	3.50-12.40	Aluminum alloy Brass Copper Silver alloy	2-007 2-008 2-008 2-008	1610 1611 1611 1611	0.451 0.445 0.300 0.321	13.99

See footnotes at end of table.

12 June 1975

TABLE 6.XXVII. Single-ridged waveguides, bandwidth ratio 3.6:1 (MIL-W-25351) -Continued.

Type 1/ designation	Cutoff for TE ₁₀ mode GHZ 4.237	Cutoff for TE ₂₀ mode GHZ 18.613	Recommended frequency range TE ₁₀ mode GHZ 5.00-18.00	Material	Flange used with		$f = \sqrt{3} f_{c10} \frac{2}{2}$	
					MIL-F-39000/()	UG-()/U	Theoretical attenuation 3/ decibels/foot	Peak power rating 4/ kilowatts
WRS500D36-				Aluminum alloy Brass Copper Silver alloy	2-010 2-011 2-011 2-011	1613 1614 1614 1614	0.771 0.761 0.513 0.549	6.857
WRS124C36-	10.508	46.162	12.40-40.00	Aluminum alloy Brass Copper Silver alloy	2-013 2-014 2-014 2-014	1616 1617 1617 1617	3.019 2.981 2.008 2.150	1.115

1/ Complete type designation will include an additional symbol (A, B, C, or S) to indicate material.

2/ f_{c10} = cutoff frequency for TE₁₀ mode.

3/ Typical resistivities of materials (at 20°C): Aluminum alloy (6061) = 4.0 microhm-cm; Brass = 3.9 microhm-cm; Copper = 1.77 microhm-cm; Silver alloy (coin silver) = 2.03 microhm-cm.

4/ Based on the H field produced break down in a nonpressurized air dielectric wave guide under continuous wave (cw) conditions. The breakdown strength of air was considered to be 15,000 volts per centimeter, corner radii considered.

TABLE 6. XXVIII. Double-ridged waveguides, bandwidth ratio 2.4:1 (MIL-W-23351/4).

Type 1/ designation	Cutoff for TE ₁₀ mode	Cutoff for TE ₂₀ mode	Recommended frequency range TE ₁₀ mode	Material	Flange used with		f =	
					MIL-F-39000/()	UG-()/U	Theoretical attenuation 3/ decibels/foot	Peak power rating 4/ kilowatts
WRD175U24-	GHZ 0.146	GHZ 0.430	GHZ 0.175-0.420	Aluminum alloy	---	---	0.00035	61,960
				Brass	---	---	0.00034	
				Copper	---	---	0.00023	
				Silver alloy	---	---	0.00025	
WRD267U24-	0.222	0.657	0.267-0.640	Aluminum alloy	---	---	0.00065	26,570
				Brass	---	---	0.00064	
				Copper	---	---	0.00043	
				Silver alloy	---	---	0.00046	
WRD420U24-	0.350	1.034	0.420-1.000	Aluminum alloy	---	---	.00128	10,710
				Brass	---	---	.00126	
				Copper	---	---	.00085	
				Silver alloy	---	---	.00091	
WRD640U24-	0.533	1.575	0.640-1.530	Aluminum alloy	---	---	0.0024	4,620
				Brass	---	---	0.0024	
				Copper	---	---	0.0016	
				Silver alloy	---	---	0.0017	
WRD840U24-	0.700	2.068	0.840-2.000	Aluminum alloy	3-001	1565	0.0036	2,676
				Brass	3-002	1566	0.0036	
				Copper	3-002	1566	0.0024	
				Silver alloy	3-002	1566	0.0026	
WRD150D24-	1.249	3.692	1.500-3.600	Aluminum alloy	3-004	1568	0.0087	840.5
				Brass	3-005	1569	0.0086	
				Copper	3-005	1569	0.0058	
				Silver alloy	3-005	1569	0.0062	
WRD200D24-	1.666	4.925	2.000-4.800	Aluminum alloy	3-007	1571	0.0134	472.5
				Brass	3-008	1572	0.0132	
				Copper	3-008	1572	0.0089	
				Silver alloy	3-008	1572	0.0095	

See footnotes at end of table.

TABLE 6. XXVIII. Double-ridged waveguides, bandwidth ratio 2.4:1 (MIL-W-23351/4) -Continued.

Type 1/ designation	Cutoff for TE ₁₀ mode GHZ	Cutoff for TE ₂₀ mode GHZ	Recommended frequency range TE ₁₀ mode GHZ	Material	Flange used with		f =											
					MIL-P-39000/()	UG-()/U	Theoretical attenuation 3/ decibels/foot	Peak power rating 4/ kilowatts										
WRD350D24-	2.915	8.620	3.500-8.200	Aluminum alloy Brass Copper Silver alloy	3-010 3-011 3-011 3-011	1574 1575 1575 1575	0.0307 0.0303 0.0204 0.0218	151.3										
									Aluminum alloy Brass Copper Silver alloy	3-013 3-014 3-014 3-014	1577 1578 1578 1578	0.0487 0.0481 0.0324 0.0347	85.72					
														Aluminum alloy Brass Copper Silver alloy	3-016 3-017 3-017 3-017	1580 1581 1581 1581	0.0964 0.0951 0.0641 0.0686	33.58
Aluminum alloy Brass Copper Silver alloy	3-022 3-023 3-023 3-023	1586 1587 1587 1587	0.358 0.353 0.238 0.255	5.834														

1/ Complete type designation will include an additional symbol (A, B, C, or S) to indicate material.

2/ f_{c10} = cutoff frequency for TE₁₀ mode.

3/ Typical resistivities of materials (at 20°C): Aluminum alloy (6061) = 4.00 microhm-cm; Brass = 3.9 microhm-cm; Copper = 1.77 microhm-cm; Silver alloy (coin silver) = 2.03 microhm-cm.

4/ Based on the E field produced breakdown in a nonpressurized air dielectric waveguide under continuous wave (cw) conditions. The breakdown strength of air was considered to be 15,000 volts per centimeter, corner radii considered.

MIL-HDBK-216
SECTION 6B
12 June 1975

TABLE 6.XXIX. Double-ridged waveguides, bandwidth ratio 3.6:1 (MIL-W-23351).

Type 1/ designation	Cutoff for TE ₁₀ mode GHZ 0.092	Cutoff for TE ₂₀ mode GHZ 0.399	Recommended frequency range TE ₁₀ mode GHZ 0.108-0.390	Material	Flange used with		f =	
					MIL-P-39000/()	UG-()/U	Theoretical attenuation 3/ decibels/foot	Peak power rating 4/ kilowatts
WRD108U36-				Aluminum alloy Brass Copper Silver alloy	---	---	0.00065 0.00064 0.00043 0.00046	28,850
WRD270U36-				Aluminum alloy Brass Copper Silver alloy	---	---	0.00235 0.00232 0.00156 0.00167	4,653
WRD390U36-				Aluminum alloy Brass Copper Silver alloy	---	---	0.00415 0.00410 0.00276 0.00296	2,227
WRD970U36-				Aluminum alloy Brass Copper Silver alloy	4-001 4-002 4-002 4-002	1589 1590 1590 1590	0.0155 0.0153 0.0103 0.0110	361.2
WRD140D36-				Aluminum alloy Brass Copper Silver alloy	4-004 4-005 4-005 4-005	1592 1593 1593 1593	0.0283 0.0279 0.0188 0.0201	173.5
WRD350D36-				Aluminum alloy Brass Copper Silver alloy	4-007 4-008 4-008 4-008	1595 1596 1596 1596	0.110 0.108 0.0729 0.0781	27.74

See footnotes at end of table.

TABLE 6.XXIX. Double-ridged waveguides, bandwidth ratio 3.6:1 (MIL-W-23351) -Continued.

Type 1/ designation	Cutoff for TE ₁₀ mode GHZ 4.222	Cutoff for TE ₂₀ mode GHZ 18.401	Recommended frequency range TE ₁₀ mode GHZ 5.00-18.00	Material	Flange used with		f =	
					MIL-P-39000/()	UG-()/U	Theoretical attenuation 3/ decibels/foot	Peak power rating 4/ kilowatts
WRD500D36-				Aluminum alloy Brass Copper Silver alloy	4-010 4-011 4-011 4-011	1598 1599 1599 1599	0.1926 0.1901 0.1281 0.1372	13.59
WRD124C36-	10.414	45.730	12.40-40.00	Aluminum alloy Brass Copper Silver alloy	4-013 4-014 4-014 4-014	1601 1602 1602 1602	0.737 0.727 0.490 0.525	2.210

1/ Complete type designation will include an additional symbol (A, B, C, or S) to indicate material.

2/ f_{c10} = cutoff frequency for TE₁₀ mode.

3/ Typical resistivities of materials (at 20°C): Aluminum alloy (6061) = 4.0 microhm-cm; Brass = 3.9 microhm-cm; Copper = 1.77 microhm-cm; Silver alloy (coin silver) = 2.03 microhm-cm.

4/ Based on the E field produced breakdown in a nonpressurized air dielectric waveguide under continuous wave (cw) conditions. The breakdown strength of air was considered to be 15,000 volts per centimeter, corner radii considered.

MIL-HDBK 216
SECTION 6B
12 June 1975

TABLE 6.XXX. Elliptical waveguide physical characteristics.

AN Type	Dimensions <u>1/</u> <u>2/</u>		Minimum Bend Radii			Weight lb/ft	Material
			Plane <u>3/</u>		90° Twist feet		
	A	B	E	H			
RG-387/U	4.07 (103.38)	2.50 (63.50)	20. (508.00)	42. (1066.80)	15	4.10	Pure aluminum
RG-395/U	3.00 (76.20)	1.99 (50.55)	20. (508.00)	36. (914.40)	12	2.76	
RG-379/U	2.48 (62.99)	1.56 (39.62)	18. (457.20)	30. (762.00)	8	1.12	
RG-381/U	2.10 (53.34)	1.31 (33.27)	16. (406.40)	24. (609.60)	7	1.81	
RG-396/U	1.64 (41.66)	1.05 (26.67)	12. (304.80)	18. (457.20)	4	0.97	
RG-394/U	1.38 (35.05)	0.85 (21.59)	8. (203.20)	12. (304.80)	4	0.59	
RG-380/U	1.830 (46.48)	1.35 (34.29)	36. (929.64)	48. (1219.20)	10	1.22	

1/ Dimensions are in inches.

2/ Millimeters are in parentheses.

3/ Minimum bend radius measured in inches.

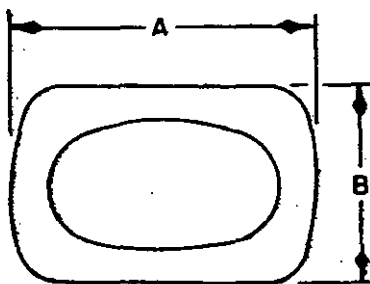

FIGURE 6.19. Elliptical waveguide cross section.

TABLE 6.XXXI. Elliptical waveguide electrical characteristics.

AN type	Suggested frequency	Cutoff frequency	Peak VSWR	Average VSWR	Peak Power midband
	<u>GHz</u>	<u>GHz</u>			<u>megawatts</u>
RG-387/U	2.7 - 3.2	2.024	1.10	1.06	4.51
RG-395/U	3.7 - 4.2	2.779	1.10	1.06	2.53
RG-381/U	4.4 - 5.0	3.433	1.06	1.03	1.66
RG-379/U	5.5 - 6.425	4.162	1.06	1.03	1.09
RG-396/U	7.1 - 8.5	5.658	1.10	1.06	0.601
RG-394/U	8.5 - 10.0	6.489	1.10	1.06	0.446
RG-380/U	6.0 - 11.0	---	1.08	1.03	---

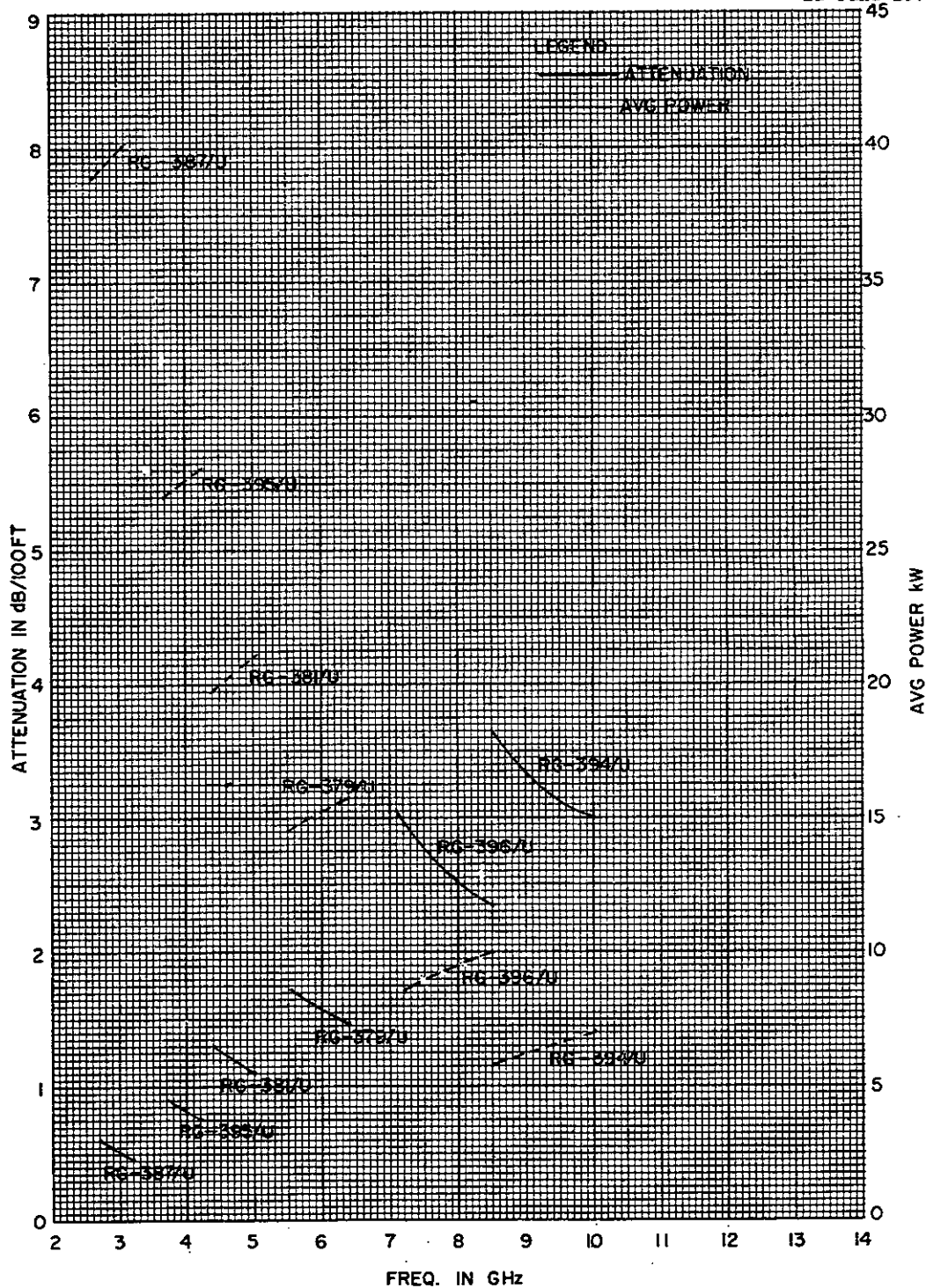

FIGURE 6.20. Elliptical waveguide attenuation and average power.

(Average power rating based on a 40°C (104°F) temperature rise over 55°C (131°F) ambient temperature and unity VSWR).

MIL-HDBK-216
SECTION 6B
12 June 1975

6.7 Dielectric waveguides.

6.7.1 General considerations. Although the theory of using a dielectric rod as a waveguide dates back to the 1930's there has been little use of dielectric waveguides until recently. Requirements for a microwave transmission line which is not affected by EMP (electro-magnetic pulse) or lightning interference led to renewed interest in dielectric waveguides during the late 1960's.

6.7.2 Mechanical properties. A dielectric waveguide consists of a dielectric core surrounded by a dielectric material with a different dielectric constant than the core. Propagation takes place by reflection from the boundary between core and surrounding material. The surrounding material may be air or some other dielectric material. A commonly used dielectric waveguide configuration is a polyethylene core surrounded by a polystyrene foam material, see figure 6.21.

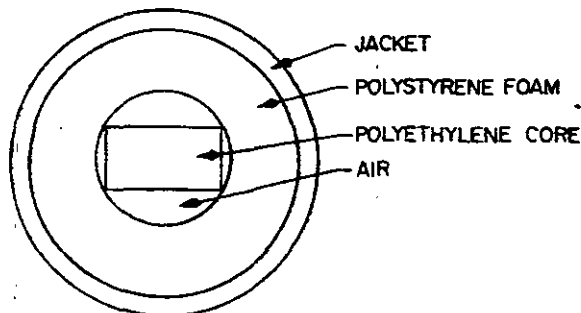

FIGURE 6.21. Typical dielectric waveguide.

6.7.3 Electrical properties. Propagation in this type of dielectric waveguide is via the E_{11} mode that has a field pattern very similar to the TE_{10} mode in standard metallic rectangular waveguide. Launches are used at each end of the dielectric waveguide to convert to standard metallic rectangular waveguide.

SECTION 7B

WAVEGUIDE COUPLINGS

7.1 General considerations. A waveguide coupling is a device used to physically and electrically join two or more sections of waveguide. The coupling is designed to provide mechanical and electrical properties to complement the physical and electrical performance of the waveguide; i.e., to act as a continuation of the waveguide. The coupling usually consists of two flat-faced metallic flanges, each soldered, welded, or brazed to the ends of the waveguides.

7.1.1 Waveguide flange types. Waveguide flanges may be grouped into three general classes; contact flanges, cover flanges, and choke flanges.

7.1.1.1 Contact flanges. Contact flanges are designed to mate with an identical flange. These flanges usually incorporate a gasket at the junction between flange faces to provide pressure sealing and enhance RF contact between flanges. The flange is mounted to the waveguide by inserting the waveguide through the flange and machining the flange face flat or by terminating the waveguide in a raised or recessed socket in the back of the flange. The gasket used with these flanges may be an O-ring type that is inserted in a groove machined into the flange face, or a one piece metal-rubber gasket may be used. The metal-rubber gasket is a metal plate using the same inside and outside dimensions and the same hole pattern as the mating flanges. A rubber sealing section is molded into the metal plate around the waveguide opening. A raised electrical contact area around the waveguide opening assures a low resistance contact area. When the O-ring type gasket is used, the O-ring provides pressure sealing and a raised area around the waveguide opening provides electrical contact. Care must be exercised to avoid pinched O-rings with resulting poor electrical contact at the flange face. Contact flanges are round in the millimeter frequency ranges, square from roughly 8 to 40 GHz, and rectangular at lower frequencies. Flanges for use above 26 GHz utilize alignment pins that are usually inserted after the flanges are attached to the waveguide. These pins insure accurate alignment of the interior surfaces of the waveguide at the flange junction. Contact flanges are usually made from various brass or aluminum alloys, depending on the method of manufacture. Flanges may be machined from forgings, castings, or bar stock. A typical contact coupling and gasket to be used with the coupling are shown in figures 7.1 and 7.2.

7.1.1.2 Choke flanges. Choke flanges are designed to be mated with cover flanges. Choke flanges use a quarter-wave deep groove around the waveguide opening plus a quarter-wave long noncontacting distance on the waveguide face to produce a half-wave transmission line at the midband of the flange operating frequency range. This transmission line presents a zero impedance to the waveguide at the flange face without physical contact. Choke flanges are used over the range of roughly 4 to 26 GHz. Above this range the performance of the choke as a zero impedance device falls off due to the wide band widths and very close tolerances required at these frequencies. Below this range the power levels used in current systems cause arcing and overheating of choke junctions if the choke couplings are used at band edges, or if sharp corners or foreign materials are present in the choke groove. Very high power systems usually use contact flanges with gaskets to provide very low resistance connections. Choke flanges include an O-ring installed in the flange face to provide a pressure tight system. The O-ring is installed near the junction between the two quarter-wave lines because it is then at a low current location where contact is noncritical. Choke flanges are mounted to waveguides by a raised or recessed socket. The socket may be formed by cross slotting the raised back of the flange or by milling a recessed area into the back of the flange. The waveguide is then soldered or brazed into the mounting. A typical choke coupling is shown in figure 7.3.

MIL-HDBK-216
SECTION 7B
28 April 1977

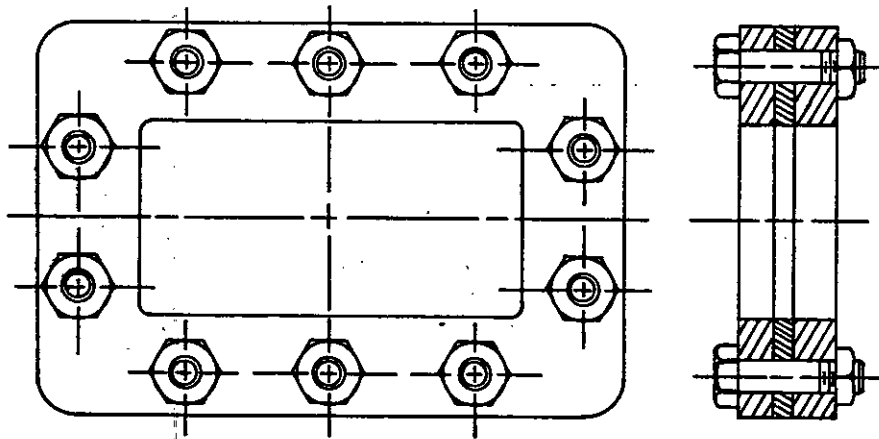

FIGURE 7.1. Typical contact coupling.

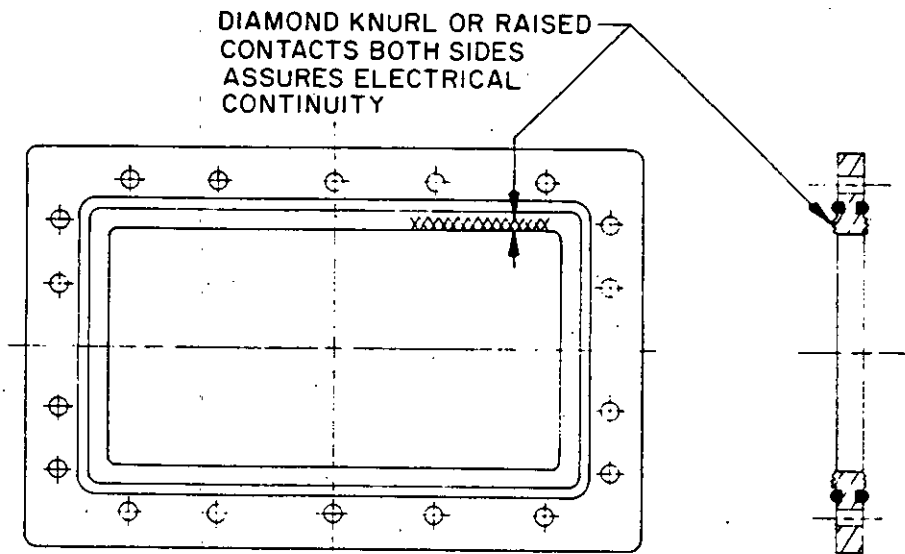

FIGURE 7.2. Typical waveguide gasket.

MIL-HDBK-216
SECTION 7B
28 April 1977

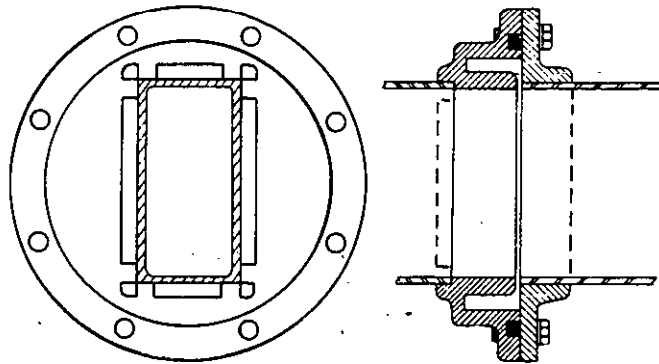

FIGURE 7.3. Typical choke coupling.

7.1.1.3 Cover flanges. A cover flange is the mate of a choke flange. Its purpose is to provide a flat surface to serve as one side of the half wave line in the choke flange. The cover flange is usually mounted by extending the waveguide through the flange and machining off the flange face after brazing or soldering. A cover flange may use a socket or butt mounting, if desirable. Gaskets (MIL-G-24211), permit the use of a waveguide connection using two cover flanges, and provide pressure sealing. These gaskets reduce the flange contact resistance.

7.1.1.4 Types of mountings. Waveguide flanges are mounted by extending the waveguide through the flange and machining off the flange face (sleeve flange), terminating the end of the waveguide in a raised corral (butt mount), or terminating the end of the waveguide in a recessed socket (socket mounting). The connector area in a butt mounted flange is constructed by cross milling grooves in the raised back of the flange to form the connection area. In the socket mounted flange the socket is constructed by milling a rectangular hole the size to accommodate the waveguide, into the back of the flange. Flanges for heavy wall or reduced height waveguides may be constructed easily from standard size flange blanks by using the socket type of waveguide to flange interface. The sleeve type mounting is used exclusively in the larger waveguide sizes (frequency ranges below 1 GHz) where a very strong flange is required, and in the very small waveguide sizes (frequency ranges above 40 GHz) where the tolerances necessary for constructing an acceptable butt or socket mounting become prohibitively expensive or unobtainable. The butt and socket type mountings are used predominately in the 2 to 40 GHz range where the ease of assembly (with satisfactory electrical properties) of these mounting types become an economic advantage.

7.1.2 Special types of couplings. Lengths of waveguides may be joined without the use of flanges. Certain components such as rigid waveguide bends or twists may be constructed with a butt or socket type interface for direct connection of the waveguide without the use of flanges. This type of connection is used to join waveguides that make up a nonrepairable assembly since the connection must be soldered or brazed and therefore becomes a permanent connection.

7.2 Dimensioning and tolerancing. Dimensions on engineering drawings are intended to specify the theoretically exact location of a feature on an object. Tolerances are included with the dimensions to specify an acceptable departure from the ideal location. The simplest way to specify these dimensions and tolerances on a drawing is to use the rectangular coordinate system, where maximum and minimum tolerances are assigned to each dimension. This system works well for most objects composed of flat, plane surfaces or outside dimensions but leaves much to be desired when specifying dimensions and tolerances of mating parts such as waveguide flanges. The positional system of dimensioning and tolerancing was designed to specify the location and tolerancing of features with respect to the actual function and fit of the parts. When this system is applied to

MIL-HDBK-216
SECTION 7B
28 April 1977

specifying waveguide flanges, the exact dimensions and tolerances necessary to obtain the desired waveguide junction performance may be obtained. Detailed information on the application of positional tolerancing to waveguide flanges may be found in Dimensioning and Tolerancing, ANSI Y14.5-1973, The American Society of Mechanical Engineers, New York, NY 10017.

7.3 Waveguide flanges and coupling assemblies. Waveguide flanges and coupling assemblies used by the military services are:

- a. Rectangular flanges - MIL-F-3922/52 through MIL-F-3922/76.
- b. Single ridge flanges - M39000/1-001 through M39000/1-024 and M39000/2-001 through M39000/2-015.
- c. Double ridge flanges - M39000/3-001 through M39000/3-024 and M39000/4-001 through M39000/4-015.
- d. Coupling assemblies - M39004/1-001 through M39004/1-005 and M39004/2-001.

7.4 Cross-reference tables. Information on cross reference of waveguide flange type designation to part number, superseded obsolete and canceled types to substitute part number, and parts approved for use but not covered by specification are included in tables 7.I, 7.II, and 7.III, respectively.

MIL-HDBK-216
SECTION 7B
28 April 1977

TABLE 7.I. Cross reference (type designation to part number).

Type designation UG- /U	Part number	Type designation UG- /U	Part number
39	M3922/53-001	1356	M3922/52-039
40B	59-006	1357	52-040
51	53-002	1358	52-041
52B	59-007	1359	52-042
53	56-001	1360	52-043
54B	61-002	1361	52-044
135	53-003	1362	52-023
136B	59-008	1475	63-001
137B	59-009	1476	63-002
138	53-004	1477	63-003
148C	62-002	1478	63-004
149A	57-002	1479	64-001
343B	60-001	1480	63-005
344	55-001	1481	63-006
383	67-001	1482	63-007
385	67-002	1483	63-008
387	67-003	1484	64-002
406B	62-001	1493	70-001
407	57-001	1494	69-001
417B	58-007	1521	65-001
418B	58-008	1522	66-001
419	53-005	1523	66-002
435B	58-009	1524	66-003
437B	58-010	1525	66-004
440B	60-002	1526	66-005
441	55-002	1527	66-006
541A	59-001	1528	66-007
553A	58-011	1529	65-002
554A	58-012	1530	54-004
584	56-002	1541	M39000/1-001
585A	61-001	1542	1-002
595	54-001	1543	1-003
596A	59-003	1544	1-004
597	54-002	1545	1-005
598A	59-004	1546	1-006
599	54-003	1547	1-007
600A	59-005	1548	1-008
1343	52-024	1549	1-009
1344	52-027	1550	1-010
1345	52-028	1551	1-011
1346	52-029	1552	1-012
1347	52-030	1553	1-013
1348	52-031	1554	1-014
1349	52-032	1555	1-015
1350	52-033	1556	1-016
1351	52-034	1557	1-017
1352	52-035	1558	1-018
1353	52-036	1559	1-019
1354	52-037	1560	1-020
1355	52-038	1561	1-021

MIL-HDBK-216
SECTION 7B
28 April 1977

TABLE 7.1. Cross reference (type designation to part number) - Continued.

Type designation UG- /U	Part number	Type designation UG- /U	Part number
1562	M39000/1-022	1607	M39000/2-004
1563	1-023	1608	2-005
1564	1-024	1609	2-006
1565	3-001	1610	2-007
1566	3-002	1611	2-008
1567	3-003	1612	2-009
1568	3-004	1613	2-010
1569	3-005	1614	2-011
1570	3-006	1615	2-012
1571	3-007	1616	2-013
1572	3-008	1617	2-014
1573	3-009	1618	2-015
1574	3-010	1665	M3922/53-006
1575	3-011	1666	59-002
1576	3-012	1711	52-006
1577	3-013	1712	52-007
1578	3-014	1713	52-008
1579	3-015	1714	52-001
1580	3-016	1715	52-003
1581	3-017	1716	52-005
1582	3-018	1717	52-004
1583	3-019	1718	52-025
1584	3-020	1719	52-026
1585	3-021	1720	52-002
1586	3-022	1724	52-009
1587	3-023	1725	52-010
1588	3-024	1726	52-011
1589	4-001	1727	52-012
1590	4-002	1728	52-013
1591	4-003	1729	52-014
1592	4-004	1730	52-015
1593	4-005	1731	52-016
1594	4-006	1732	52-017
1595	4-007	1733	52-018
1596	4-008	1734	52-019
1597	4-009	1735	52-020
1598	4-010	1736	52-021
1599	4-011	1737	52-022
1600	4-012		
1601	4-013		
1602	4-014		
1603	4-015		
1604	2-001		
1605	2-002		
1606	2-003		

MIL-HDBK-216
SECTION 7B
28 April 1977

TABLE 7.II. Cross reference (superseded, obsolete, or canceled types to substitute part number).

Superseded flange type UG-	Part number M3922/
41	53-002
42	59-007
52, 52A	59-007
54, 54A	61-002
65	52-031
116	54-001
66	52-031
117	59-003
136, 136A	59-008
137, 137A	59-009
148B	62-002
164	56-001
165	61-002
210	59-003
200	61-002
211	54-001
214	56-001
322, 323	52-023
343, 343A	60-001
406, 406A	62-001
417, 417A	58-007
418, 418A	58-008
435, 435A	58-009
437, 437A	58-010
541	59-001
553	58-011
554	58-012
585	61-001
596	59-003
598	59-004
600	59-005
1905	71-13
1907	71-17
1908	71-15
1910	72-05
1911	73-05

MIL-HDBK-216
SECTION 7B
28 April 1977

TABLE 7.III. Parts approved for use (not covered
by specification)

Part	Manufacturers code
UG-509/U	80058
UG-510/U	80058
UG-511/U	80058
UG-512/U	80058
UG-1641/U	80058
UG-1642/U	80058
UG-1906/U	80058
UG-1909/U	80058
171378	24930
2667831-1	49956
2667831-2	49956
2667831-3	49956
2667831-4	49956
2667831-5	49956

MIL-HDBK-216
SECTION 8 A
7 April 1967
SUPERSEDING
Section 8
4 January 1962

SECTION 8 A
WAVEGUIDE ASSEMBLIES

8.1 General considerations.

See section 6.

8.2 Tables.

Table 8. I is a list of flexible waveguide assemblies. - The type designation is in the following form:

FG	090	A	CC	A	06
— —	— —	— —	— —	— —	— —
Component	Size	Type	Flange arrangement	Material of flange	Length

(a) Component. Twistable and nontwistable, flexible waveguide assemblies are identified by the two-letter symbol "FG"

(b) Size. The size is identified by a three-digit number indicating the inner width dimension of the matched rigid rectangular waveguide, to the nearest one-hundredth of an inch, with which the twistable or nontwistable, flexible waveguide assembly will make.

(c) Type. The type is identified by a letter which designates flexible waveguide assemblies of the same size but having different performance characteristics, as follows:

Type A - Twistable.
Type B - Nontwistable.
Type C - Extra flexible.

(d) Flange arrangement. The termination of the assemblies shall be identified by the following letters:

<u>End 1</u>	<u>End 2</u>
CC - Choke	Cover
DD - Cover	Cover
EE - Contact	Contact

(e) Material of flange. The flange material shall be identified by a letter as follows:

A - Aluminum
B - Brass

(f) Length. The length is identified by a two-digit number indicating the nominal relaxed length of the flexible waveguide assembly, measured from the face of one flange to the face of the other, and expressed in inches. When the required length is 6 inches, the number 6 is preceded by a zero.

Table 8. II lists the VSWR and bandwidth data for bends, corners and twists for the rigid waveguide assemblies.

Table 8. III is a cross reference of CG designated types to FG designated types.

Table 8. IV is a list of waveguide assemblies and a list to the selection of preferred waveguide assemblies. This guide contains those assemblies which have been selected by the Armed Services as the preferred types for use in electronic equipment. The purpose of this guide is to standardize waveguide assemblies and to limit the number of types used in the equipment of the Armed Services.

Table 8. V lists rigid waveguide assemblies, denoting functional description, engineering data, etc.

MIL-HDBK-216
SECTION 8 A
7 April 1967

TABLE 8. I. Flexible waveguide assemblies.

Type designation	Dash number / M287/1-	TE ₁₀ mode frequency range (GHz)	Min bending angle (degrees/ft)		Repeated twist (degrees/ft)		Attenuation (db/100 ft)	Axial twist (degrees/ft)	Pressurization oper (psig)	VSWR	Flanges		Standard rigid waveguide equivalent RG-(/)/U	Flexure (degrees/ft)	
			E plane	H plane	400 cycles	1 x 10 ⁶ cycles					1	2		E plane	H plane
FG650AEEB--	001 - 016	1.12 - 1.70	28.5	14.3	5	1.5	0.5	10	2	1.10	417A	417A	690	4.5	2.2
FG430AEEB--	017 - 032	1.70 - 2.60	55.5	26.5	7.5	2.25	1	15	4	1.10	435A	435A	104	7.5	3.6
FG340AEEB--	033 - 048	2.20 - 3.30	61.7	35.0	11	3.3	1.5	22	5	1.10	553	553	112	9	5.25
FG284AEEB--	049 - 064	2.60 - 3.85	100.0	47.8	14.5	4.5	2	28	15	1.10	1479	1479	48	13.3	6.4
FG187AEEB--	065 - 080	3.85 - 5.85	139.2	57.1	25	7.5	5	50	30	1.10	1475	1475	49	18.7	7.6
FG137AEEB--	081 - 096	5.85 - 8.20	177.4	74.3	35	10.5	8	70	30	1.10	1476	1476	50	24	10.2
FG112AEEB--	097 - 112	7.05 - 10.00	193.0	82.0	42.5	12.75	8	85	30	1.15	1477	1477	51	26.1	11.1
FG090AEEB--	113 - 128	8.20 - 12.40	203.7	91.6	47.5	14.25	10	95	30	1.15	1478	1478	52	27.5	12.3
FG650AEEA--	129 - 144	1.12 - 1.70	28.5	14.3	5	1.5	0.5	10	2	1.10	418A	418A	103	4.5	2.2
FG430AEEA--	145 - 160	1.70 - 2.60	55.5	26.5	7.5	2.25	1	15	4	1.10	437A	437A	105	7.5	3.6
FG340AEEA--	161 - 176	2.20 - 3.30	61.7	35.0	11	3.3	1.5	22	5	1.10	554	554	113	9	5.25
FG284AEEA--	177 - 192	2.60 - 3.85	100.0	47.8	14.5	4.5	2	28	15	1.10	1484	1484	75	13.3	6.4
FG187AEEA--	193 - 208	3.85 - 5.85	139.2	57.1	25	7.5	5	50	30	1.10	1480	1480	95	18.7	7.6
FG137AEEA--	209 - 224	5.85 - 8.20	177.4	74.3	35	10.5	8	70	30	1.10	1481	1481	106	24	10.2
FG112AEEA--	225 - 240	7.05 - 10.00	193.0	82.0	42.5	12.75	8	85	30	1.15	1482	1482	68	26.1	11.1
FG090AEEA--	241 - 256	8.20 - 12.40	203.7	91.6	47.5	14.25	10	95	30	1.15	1483	1483	67	27.5	12.3
FG284ACCB--	257 - 272	2.60 - 3.85	100.0	47.8	14.5	4.5	2	28	15	1.10	54B	54B	48	13.3	6.4
FG187ACCB--	273 - 288	3.85 - 5.85	139.2	57.1	25	7.5	5	50	30	1.10	148C	148C	49	18.7	7.6
FG137ACCB--	289 - 304	5.85 - 8.20	177.4	74.3	35	10.5	8	70	30	1.10	344B	344B	50	24	10.2
FG090ACCB--	305 - 320	7.05 - 10.00	193.0	82.0	42.5	12.75	8	85	30	1.15	52B	52B	51	26.1	11.1
FG062ACCB--	321 - 336	8.20 - 12.40	203.7	91.6	47.5	14.25	10	95	30	1.15	40B	40B	52	27.5	12.3
FG042ACCB--	337 - 352	12.40 - 18.00	250.0	119.5	60	18.00	20	120	30	1.20	541A	541A	91	33.7	16.2
FG024ACCB--	353 - 368	16.00 - 26.50	295.0	152.7	82.5	24.25	35	165	30	1.20	599A	599A	53	45	22.5
FG284ACCA--	369 - 384	2.60 - 3.85	100.0	47.8	14.5	4.5	2	28	15	1.10	585A	585A	75	13.3	6.4
FG187ACCA--	385 - 400	3.85 - 5.85	139.2	57.1	25	7.5	5	50	30	1.10	408B	408B	95	18.7	7.6
FG137ACCA--	401 - 416	5.85 - 8.20	177.4	74.3	35	10.5	8	70	30	1.10	440B	440B	106	24	10.2
FG090ACCA--	417 - 432	7.05 - 10.00	193.0	82.0	42.5	12.75	8	85	30	1.15	137B	137B	68	26.1	11.1
FG062ACCA--	433 - 448	8.20 - 12.40	203.7	91.6	47.5	14.25	10	95	30	1.15	136B	136B	67	27.5	12.3
FG042ACCA--	449 - 464	12.40 - 18.00	250.0	119.5	60	18.00	20	120	30	1.20	1165	1165	349	33.7	16.2
FG024ACCA--	465 - 480	16.00 - 26.50	295.0	152.7	82.5	24.25	35	165	30	1.20	599A	599A	121	45	22.5
FG284ADDB--	481 - 496	2.60 - 3.85	100.0	47.8	14.5	4.5	2	28	15	1.10	53	53	48	13.3	6.4
FG187ADDB--	497 - 512	3.85 - 5.85	139.2	57.1	25	7.5	5	50	30	1.10	149A	149A	49	18.7	7.6
FG137ADDB--	513 - 528	5.85 - 8.20	177.4	74.3	35	10.5	8	70	30	1.10	344	344	50	24	10.2
FG090ADDB--	529 - 544	7.05 - 10.00	193.0	82.0	42.5	12.75	8	85	30	1.15	51	51	51	26.1	11.1
FG062ADDB--	545 - 560	8.20 - 12.40	203.7	91.6	47.5	14.25	10	95	30	1.15	39	39	52	27.5	12.3
FG042ADDB--	561 - 576	12.40 - 18.00	250.0	119.5	60	18.00	20	120	30	1.20	419	419	91	33.7	16.2
FG024ADDB--	577 - 592	16.00 - 26.50	295.0	152.7	82.5	24.25	35	165	30	1.20	595	595	53	45	22.5
FG284ADDA--	593 - 608	2.60 - 3.85	100.0	47.8	14.5	4.5	2	28	15	1.10	584	584	75	13.3	6.4
FG187ADDA--	609 - 624	3.85 - 5.85	139.2	57.1	25	7.5	5	50	30	1.10	407	407	95	18.7	7.6
FG137ADDA--	625 - 640	5.85 - 8.20	177.4	74.3	35	10.5	8	70	30	1.10	441	441	106	24	10.2
FG090ADDA--	641 - 656	7.05 - 10.00	193.0	82.0	42.5	12.75	8	85	30	1.15	138	138	68	26.1	11.1
FG062ADDA--	657 - 672	8.20 - 12.40	203.7	91.6	47.5	14.25	10	95	30	1.15	135	135	67	27.5	12.3
FG042ADDA--	673 - 688	12.40 - 18.00	250.0	119.5	60	18.00	20	120	30	1.20	1165	1165	349	33.7	16.2
FG024ADDA--	689 - 704	16.00 - 26.50	295.0	152.7	82.5	24.25	35	165	30	1.20	597	597	121	45	22.5

See footnote at end of table.

MIL-HDBK-216
SECTION 8 A
7 April 1967

TABLE 8. I. Flexible waveguide assemblies - Continued.

Type designation	Dash number / M287/2-	TE ₁₀ mode frequency range (GHz)	Min bending angles (degrees/ft)		Repeated twist (degrees/ft)		Attenuation (db/100 ft)	Axial twist (degrees/ft)	Pressurization (psig)	VSWR	Flanges		Standard rigid waveguide equivalent RG- (/U)	Flexure (degrees/ft)	
			E plane	H plane	400 cycles	1 x 10 ⁶ cycles					1	2		E plane	H plane
FG650CEB--	001 - 016	1.12 - 1.70	52.8	25.4	27	6	2.5	54	2	1.10	417A	417A	69	7.2	3.6
FG340CEB--	017 - 032	1.70 - 2.60	72.3	49.1	30	9	3.5	60	20	1.10	435A	435A	104	8.6	4.3
FG340CEB--	033 - 048	2.20 - 3.30	114.5	85.9	35	10.5	5	70	30	1.10	553	553	112	10.5	5.28
FG284CEB--	049 - 064	2.60 - 3.95	152.7	107.8	42	12.6	6	84	40	1.10	1479	1479	48	11.5	7.5
FG187CEB--	085 - 080	3.95 - 5.85	239.1	144.7	67.5	20.25	7	135	45	1.10	1475	1475	49	18	9.5
FG137CEB--	081 - 086	5.85 - 8.20	275.0	144.7	70	21	8	140	45	1.12	1476	1476	50	26.5	13.25
FG112CEB--	087 - 112	7.05 - 10.00	343.7	171.8	90	27	8	180	45	1.15	1477	1477	51	28.8	14.4
FG090CEB--	113 - 128	8.20 - 12.40	500.0	305.5	120	36	13	240	60	1.15	1478	1478	52	34.25	17.12
FG650CEA--	129 - 144	1.12 - 1.70	52.8	25.4	27	6	2.5	54	2	1.10	418A	418A	103	7.2	3.6
FG340CEA--	145 - 160	1.70 - 2.60	72.3	49.1	30	9	3.5	60	20	1.10	437A	437A	105	8.6	4.3
FG340CEA--	161 - 176	2.20 - 3.30	114.5	85.9	35	10.5	5	70	30	1.10	554	554	113	10.5	5.28
FG284CEA--	177 - 192	2.60 - 3.95	152.7	107.8	42	12.6	6	84	40	1.10	1484	1484	75	11.5	7.5
FG187CEA--	193 - 208	3.95 - 5.85	239.1	144.7	67.5	20.25	7	135	45	1.10	1480	1480	95	19	9.5
FG137CEA--	209 - 224	5.85 - 8.20	275.0	144.7	70	21	8	140	45	1.12	1481	1481	106	26.5	13.25
FG112CEA--	225 - 240	7.05 - 10.00	343.7	171.8	90	27	8	180	45	1.15	1482	1482	68	28.8	14.4
FG090CEA--	241 - 256	8.20 - 12.40	500.0	305.5	120	36	13	240	60	1.15	1483	1483	67	34.25	17.12
FG284CCB--	257 - 272	2.60 - 3.95	152.7	107.8	42	12.6	6	84	30	1.10	54B	53	48	11.5	7.5
FG187CCB--	273 - 288	3.95 - 5.85	229.1	144.7	67.5	20.25	7	135	45	1.10	148C	149A	49	19	9.5
FG137CCB--	289 - 304	5.85 - 8.20	275.0	144.7	70	21	8	140	45	1.12	343B	344	50	26.5	13.25
FG112CCB--	305 - 320	7.05 - 10.00	343.7	171.8	90	27	8	180	45	1.15	52B	51	51	28.8	14.4
FG090CCB--	321 - 336	8.20 - 12.40	500.0	305.5	120	36	13	240	60	1.15	40B	39	52	34.25	17.12
FG62CCB--	337 - 352	12.40 - 18.00	550.0	392.8	120	36	30	250	60	1.20	541A	419	91	53.0	26.5
FG42CCB--	353 - 368	18.00 - 26.50	611.1	550.0	132	30	35	264	60	1.20	596A	595	53	69.0	34.5
FG284CCA--	369 - 384	2.60 - 3.95	152.7	107.8	42	12.6	6	84	30	1.10	585A	584	75	11.5	7.5
FG187CCA--	385 - 400	3.95 - 5.85	229.1	144.7	67.5	20.25	7	135	45	1.10	406B	407	85	19	9.5
FG137CCA--	401 - 416	5.85 - 8.20	275.0	144.7	70	21	8	140	45	1.12	440B	441	106	26.5	13.25
FG112CCA--	417 - 432	7.05 - 10.00	343.7	171.8	90	27	8	180	45	1.15	137B	138	68	28.8	14.4
FG090CCA--	433 - 448	8.20 - 12.40	500.0	305.5	120	36	13	240	60	1.15	136B	135	67	34.25	17.12
FG62CCA--	449 - 464	12.40 - 18.00	550.0	392.8	120	36	30	250	60	1.20	1166	1165	349	53.0	26.5
FG42CCA--	465 - 480	18.00 - 26.50	611.1	550.0	132	30	35	264	60	1.20	598A	597	121	69.0	34.5
FG284CDB--	481 - 496	2.60 - 3.95	152.7	107.8	42	12.6	6	84	30	1.10	53	53	48	11.5	7.5
FG187CDB--	497 - 512	3.95 - 5.85	229.1	144.7	67.5	20.25	7	135	45	1.10	149A	149A	49	19	9.5
FG137CDB--	513 - 528	5.85 - 8.20	275.0	144.7	70	21	8	140	45	1.12	344	344	50	26.5	13.25
FG112CDB--	529 - 544	7.05 - 10.00	343.7	171.8	90	27	8	180	45	1.15	51	51	51	28.8	14.4
FG090CDB--	545 - 560	8.20 - 12.40	500.0	305.5	120	36	13	240	60	1.15	39	39	52	34.25	17.12
FG62CDB--	561 - 576	12.40 - 18.00	550.0	392.8	120	36	30	250	60	1.20	419	419	91	53.0	26.5
FG42CDB--	577 - 592	18.00 - 26.50	611.1	550.0	132	30	35	264	60	1.20	595	595	53	69.0	34.5
FG284CDDA--	593 - 608	2.60 - 3.95	152.7	107.8	42	12.6	6	84	30	1.10	584	584	75	11.5	7.5
FG187CDDA--	609 - 624	3.95 - 5.85	229.1	144.7	67.5	20.25	7	135	45	1.10	407	407	95	19	9.5
FG137CDDA--	625 - 640	5.85 - 8.20	275.0	144.7	70	21	8	140	45	1.12	441	441	106	26.5	13.25
FG112CDDA--	641 - 656	7.05 - 10.00	343.7	171.8	90	27	8	180	45	1.15	138	138	68	28.8	14.4
FG090CDDA--	657 - 672	8.20 - 12.40	500.0	305.5	120	36	13	240	60	1.15	135	135	67	34.25	17.12
FG62CDDA--	673 - 688	12.40 - 18.00	550.0	392.8	120	36	30	250	60	1.20	1165	1165	349	53.0	26.5
FG42CDDA--	689 - 704	18.00 - 26.50	611.1	550.0	132	30	35	264	60	1.20	597	597	121	69.0	34.5

See footnote at end of table.

MIL-HDBK-216
SECTION 8A
7 April 1967

TABLE 8. I. Flexible waveguide assemblies - Continued.

Type designation	Dash number / M287/3-	TE ₁₀ mode frequency range (GHz)	Min bending angle (degrees/ft)		Attenuation (db/100 ft)	Pressurization oper (psig)	VSWR	Flanges UG-()/U		Standard rigid waveguide equivalent RG-()/U
			E plane	H plane				1	2	
FG650BEEB--	001 - 016	1.12 - 1.70	52.8	25.4	1	15	1.05	417A	417A	69
FG430BEEB--	017 - 032	1.70 - 2.60	72.3	49.1	1.5	20	1.07	435A	435A	104
FB340BEEB--	033 - 048	2.20 - 3.30	137.5	70.5	1.8	25	1.09	553	553	112
FG284BEEB--	049 - 064	2.60 - 3.95	152.7	107.8	2	30	1.10	1479	1479	48
FG187BEEB--	065 - 080	3.95 - 5.85	229.1	125.0	3	30	1.10	1475	1475	49
FG137BEEB--	081 - 096	5.85 - 8.20	275.0	137.5	5	30	1.10	1476	1476	50
FG112BEEB--	097 - 112	7.05 - 10.00	394.0	197.0	6	45	1.10	1477	1477	51
FG080BEEB--	113 - 128	8.20 - 12.40	458.0	229.0	10	60	1.10	1478	1478	52
FG650BEEA--	129 - 144	1.12 - 1.70	52.8	25.4	1	15	1.05	418A	418A	103
FG430BEEA--	145 - 160	1.70 - 2.60	72.3	49.1	1.5	20	1.07	437A	437A	105
FG340BEEA--	161 - 176	2.20 - 3.30	137.5	70.5	1.8	25	1.09	554	554	113
FG284BEEA--	177 - 192	2.60 - 3.95	152.7	107.8	2	30	1.10	1484	1484	75
FG187BEEA--	193 - 208	3.95 - 5.85	229.1	125.0	3	30	1.10	1480	1480	95
FG137BEEA--	209 - 224	5.85 - 8.20	275.0	137.5	5	30	1.10	1481	1481	106
FG112BEEA--	225 - 240	7.05 - 10.00	394.0	197.0	6	45	1.10	1482	1482	68
FG080BEEA--	241 - 256	8.20 - 12.40	458.0	229.0	10	60	1.10	1483	1483	67
FG284BCCB--	257 - 272	2.60 - 3.95	152.7	107.8	2	30	1.10	54B	53	48
FG187BCCB--	273 - 288	3.95 - 5.85	229.1	125.0	3	30	1.10	148C	149A	49
FG137BCCB--	289 - 304	5.85 - 8.20	275.0	137.5	5	30	1.10	343B	344	50
FG112BCCB--	305 - 320	7.05 - 10.00	394.0	197.0	6	45	1.10	52B	51	51
FG080BCCB--	321 - 336	8.20 - 12.40	458.0	229.0	10	60	1.10	40B	39	52
FG650BCCB--	337 - 352	12.40 - 18.00	458.3	343.7	15	60	1.13	541A	419	91
FG042BCCB--	353 - 368	18.00 - 26.50	611.1	550.0	30	60	1.15	596A	595	53
FG284BCCA--	369 - 384	2.60 - 3.95	152.7	107.8	2	30	1.10	585A	584	75
FG187BCCA--	385 - 400	3.95 - 5.85	229.1	125.0	3	30	1.10	406B	407	95
FG137BCCA--	401 - 416	5.85 - 8.20	275.0	137.5	5	30	1.10	440B	441	106
FG112BCCA--	417 - 432	7.05 - 10.00	394.0	197.0	6	45	1.10	137B	138	68
FG080BCCA--	433 - 448	8.20 - 12.40	458.0	229.0	10	60	1.10	136B	135	67
FG650BCCA--	449 - 464	12.40 - 18.00	458.3	343.7	15	60	1.13	116B	1165	349
FG042BCCA--	465 - 480	18.00 - 26.50	611.1	550.0	30	60	1.15	598A	597	121
FG284BDDDB--	481 - 496	2.60 - 3.95	152.7	107.8	2	30	1.10	53	53	48
FG187BDDDB--	497 - 512	3.95 - 5.85	229.1	125.0	3	30	1.10	149A	149A	49
FG137BDDDB--	513 - 528	5.85 - 8.20	275.0	137.5	5	30	1.10	344	344	50
FG112BDDDB--	529 - 544	7.05 - 10.00	394.0	197.0	6	45	1.10	51	51	51
FG080BDDDB--	545 - 560	8.20 - 12.40	458.0	229.0	10	60	1.10	39	39	52
FG650BDDDB--	561 - 576	12.40 - 18.00	458.3	343.7	15	60	1.13	419	419	91
FG042BDDDB--	577 - 592	18.00 - 26.50	611.1	550.0	30	60	1.15	595	595	53
FG284BDDDA--	593 - 608	2.60 - 3.95	152.7	107.8	2	30	1.10	584	584	75
FG187BDDDA--	609 - 624	3.95 - 5.85	229.1	125.0	3	30	1.10	407	407	95
FG137BDDDA--	625 - 640	5.85 - 8.20	275.0	137.5	5	30	1.10	441	441	106
FG112BDDDA--	641 - 656	7.05 - 10.00	394.0	197.0	6	45	1.10	138	138	68
FG080BDDDA--	657 - 672	8.20 - 12.40	458.0	229.0	10	60	1.10	135	135	67
FG650BDDDA--	673 - 688	12.40 - 18.00	458.3	343.7	15	60	1.13	1165	1165	349
FG042BDDDA--	689 - 704	18.00 - 26.50	611.1	550.0	30	60	1.15	597	597	121

1/2 Each length has a separate part number; for example: M287/3-003 would be FG650BEEB18.

MIL-HDBK-216
SECTION 8A
7 April 1967

TABLE 8. II. VSWR and bandwidth data for bends, corners and twists (rigid waveguide assemblies).

BENDS								
Waveguide type	Frequency range	Bandwidth ^{1/}	Maximum VSWR					
			H-plane			E-plane		
RG () /U	(GHz)	%	90°	60°	45°	90°	60°	45°
48	2.6 - 4.0	42	1.05	1.04	1.04	1.03	1.02	1.04
49	3.950 - 5.875	39	1.05	1.04	1.05	1.05	1.05	1.05
50	5.8 - 8.2	34	1.03	1.04	1.04	1.05	1.05	1.05
51	7.0 - 10.1	36	1.07	1.05	1.05	1.05	1.04	1.05
52	8.2 - 12.4	40	1.05	1.05	1.04	1.05	1.05	1.04
91	12.4 - 18.0	37	1.04	1.05	1.05	1.05	1.05	1.05
53	18.5 - 26.0	34	1.05	1.04	1.06	1.06	1.05	1.05
96	26.0 - 40.0	42	1.05	1.10	1.08	1.08	1.10	1.08
CORNERS								
Waveguide type	Frequency range	Bandwidth ^{1/}	Maximum VSWR					
			H-plane			E-plane		
RG () /U	(GHz)	%	90°	60°	45°	90°	60°	45°
48	2.6 - 4.0	42	1.09	1.10	1.03	1.07	1.07	1.08
49	3.9 - 6.0	42	1.08	1.07	1.05	1.09	1.09	1.08
50	5.85 - 8.2	34	1.08	1.08	1.06	1.10	1.10	1.07
51	7.0 - 10.0	36	1.08	1.06	1.02	1.05	1.08	1.07
52	8.1 - 12.2	40	1.10	1.07	1.08	1.10	1.09	1.08
91	12.4 - 17.85	37	1.10	1.08	1.08	1.10	1.09	1.10
53	18.0 - 26.5	34	1.06	1.09	1.04	1.07	1.10	1.06
96	26.5 - 40.0	42	1.12	1.14	1.08	1.16	1.15	1.12
TWISTS 90° angle								
Waveguide type	Frequency range	Bandwidth ^{1/}	Maximum VSWR					
RG () /U	(GHz)	%						
48	2.6 - 4.0	42	1.02					
49	3.950 - 5.875	39	1.05					
50	5.8 - 8.2	34	1.05					
51	7.0 - 10.0	36	1.05					
52	8.2 - 12.5	37	1.05					
91	12.5 - 17.8	37	1.05					
53	18.0 - 26.0	34	1.06					
96	26.0 - 40.0	42	1.10					

$$\frac{1}{\text{Bandwidth}} = \frac{200(f_2 - f_1)}{(f_1 + f_2)}$$

when f_1 = lower frequency
when f_2 = upper frequency

MIL-HDBK-216
SECTION 8 A
7 April 1967

TABLE 8. III. Cross reference of CG to FG types.

Type		Type	
CG /U	FG-	CG /U	FG-
164	090ADDB	733	112BCCB
165A	112BDDB	734	137BCCB
166	112ADDB	735	187BCCB
167A	187BDDB	736	284ACCB
168	187ADDB	779	090BDDB
179A	090BDDB	802	090BCCA
461	090BDDB	843	137BCCB
519	284ACCB	930	284ADDA
537A	650AEEB	1093	090ACCB
538	430AEEB	1347	284ADDB
539	062ADDB	1348	187ADDB
540	112ACCB	1349	137ADDB
541	090ACCB	1350	112ADDB
730	090BCCB	1351	090ADDB
731	650AEEB	1352	042ADDB
732	090BCCB	1353	062ADDB

Table 8. IV. Guide to selection of rigid waveguide assemblies.

Waveguide TYPE	E - plane					H - plane					Straight twists	Flanges	
	Bends			Mitered corner		Bends			Mitered corner				
	45°	60°	90°	45°	60°	45°	60°	90°	45°	60°			90°
RG-48/U (WR284)	UG-728/U	UG-824/U	UG-860/U	UG-760/U	UG-744/U	UG-893/U	UG-776/U	UG-712/U	UG-792/U	UG-877/U	UG-844/U	CG-992/U	UG-53, 54B/U
RG-49/U (WR187)	UG-729/U	UG-825/U	UG-861/U	UG-761/U	UG-745/U	UG-894/U	UG-777/U	UG-713/U	UG-793/U	UG-878/U	UG-845/U	CG-994/U	UG-149A, 149C/U
RG-50/U (WR137)	UG-730/U	UG-826/U	UG-862/U	UG-762/U	UG-746/U	UG-895/U	UG-778/U	UG-714/U	UG-794/U	UG-879/U	UG-846/U	CG-980/U	UG-344, 343B/U
RG-51/U (WR112)	UG-731/U	UG-827/U	UG-863/U	UG-763/U	UG-747/U	UG-896/U	UG-779/U	UG-715/U	UG-795/U	UG-880/U	UG-847/U	CG-982/U	UG-51, 52B/U
RG-52/U (WR90)	UG-732/U	UG-828/U	UG-864/U	UG-764/U	UG-748/U	UG-897/U	UG-780/U	UG-716/U	UG-796/U	UG-881/U	UG-848/U	CG-984/U	UG-39, 40B/U
RG-53/U (WR42)	UG-733/U	UG-829/U	UG-865/U	UG-765/U	UG-749/U	UG-898/U	UG-781/U	UG-717/U	UG-797/U	UG-882/U	UG-849/U	CG-988/U	UG-595/596/U
RG-67/U (WR90)	UG-734/U	UG-830/U	UG-866/U	UG-766/U	UG-750/U	UG-899/U	UG-782/U	UG-718/U	UG-798/U	UG-883/U	UG-850/U	CG-989/U	UG-595/596/U
RG-68/U (WR112)	UG-735/U	UG-831/U	UG-867/U	UG-767/U	UG-751/U	UG-900/U	UG-783/U	UG-719/U	UG-799/U	UG-884/U	UG-851/U	CG-985/U	UG-135, 136B/U
RG-69/U (WR650)	UG-736/U	UG-832/U	UG-868/U	UG-768/U	UG-752/U	UG-901/U	UG-784/U	UG-720/U	UG-800/U	UG-885/U	UG-852/U	CG-983/U	UG-138, 137B/U
RG-75/U (WR84)	UG-737/U	UG-833/U	UG-869/U	UG-769/U	UG-753/U	UG-902/U	UG-785/U	UG-721/U	UG-801/U	UG-886/U	UG-853/U	CG-983/U	UG-584, 585A/U
RG-91/U (WR62)	UG-738/U	UG-834/U	UG-870/U	UG-770/U	UG-754/U	UG-903/U	UG-786/U	UG-722/U	UG-802/U	UG-887/U	UG-854/U	CG-986/U	UG-419, 541A/U
RG-95/U (WR187)	UG-739/U	UG-835/U	UG-871/U	UG-771/U	UG-755/U	UG-904/U	UG-787/U	UG-723/U	UG-803/U	UG-888/U	UG-855/U	CG-985/U	UG-407, 406B/U
RG-96/U (WR28)	UG-740/U	UG-836/U	UG-872/U	UG-772/U	UG-756/U	UG-905/U	UG-788/U	UG-724/U	UG-804/U	UG-889/U	UG-856/U	CG-990/U	UG-589, 600A/U
RG-97/U (WR22)													UG-383/U
RG-98/U (WR15)													UG-385/U
RG-99/U (WR12)													UG-387/U
RG-109/U (WR650)													UG-418A/U
RG-109/U (WR430)													UG-435A/U
RG-105/U (WR430)													UG-437A/U
RG-106/U (WR137)	UG-741/U	UG-837/U	UG-873/U	UG-773/U	UG-757/U	UG-906/U	UG-789/U	UG-725/U	UG-805/U	UG-890/U	UG-857/U	CG-981/U	UG-44J, 440B/U
RG-107/U (WR62)	UG-742/U	UG-838/U	UG-874/U	UG-774/U	UG-758/U	UG-907/U	UG-790/U	UG-726/U	UG-806/U	UG-891/U	UG-858/U	CG-987/U	UG-419, 541A/U
RG-121/U (WR42)	UG-743/U	UG-839/U	UG-875/U	UG-775/U	UG-759/U	UG-908/U	UG-791/U	UG-727/U	UG-807/U	UG-892/U	UG-859/U	CG-991/U	UG-597/598A/U
RG-167/U (WR284)													
RG-168/U (WR187)													
RG-169/U (WR137)													
RG-170/U (WR112)													
RG-171/U (WR90)													
RG-172/U (WR62)													
RG-173/U (WR42)													

1/ All 90° mitered corners are double-jointed. All others are single jointed or cut.

MIL-HDEK-216
SECTION 8A
7 April 1967

TABLE 8. V. Rigid waveguide assemblies

Type	Functional description	For use with waveguide types	Engineering data
UG-67/U	6-3/4 inch radius, E-bend (90°)	RG-48/U (WR284)	Includes 2 UG-66/U.
UG-68/U	6 -- inch radius, H-bend (90°)	RG-48/U (WR284)	Includes 2 UG-66/U.
UG-69A/U	3-3/4 inch radius, E-bend (90°)	RG-48/U (WR284)	Includes 2 UG-66/U. Replaces UG-69/U.
UG-70A/U	4-1/2 inch radius, H-bend (90°)	RG-48/U (WR284)	Includes 2 UG-66/U. Replaces UG-70/U.
UG-134/U	2-1/16 inch radius, E-bend (90°)	RG-51/U (WR112)	Mates with UG-51/U and UG-52B/U.
UG-152/U	Adapter	RG-51/U (WR112) RG-52/U (WR90)	Includes UG-39/U and equivalent of UG-52/U.
UG-153/U	Adapter	RG-51/U (WR112) RG-52/U (WR90)	Includes UG-50A/U and equivalent of UG-51/U.
UG-328/U	6-3/4 inch radius, E-bend (90°)	RG-69/U (WR650)	Flanges not included.
UG-329/U	6-3/4 inch radius, E-bend (90°)	RG-69/U (WR650)	Includes UG-319/U and UG-320/U.
UG-330/U	8-3/8 inch radius, H-bend (90°)	RG-69/U (WR650)	Flanges not included.
UG-331/U	8-3/8 inch radius, H-bend (90°)	RG-69/U (WR650)	Includes UG-319/U and UG-320/U.
UG-353/U	6-3/4 inch radius, E-bend (45°)	RG-69/U (WR650)	Includes UG-319/U and UG-320/U.
UG-354/U	8-3/8 inch radius, H-bend (45°)	RG-69/U (WR650)	Includes UG-319/U and UG-320/U.
UG-379/U	2-1/8 inch radius, H-bend (90°) with 2-7/8 ext. on one side	RG-51/U (WR112)	Includes UG-51/U and UG-52B/U.
UG-380/U	1-13/16 inch radius E-bend (90°) with 3-3/16 ext. on one side	RG-51/U (WR112)	Includes UG-51/U and UG-52B/U.
UG-389A/U	2-1/8 inch radius, H-bend (45°)	RG-51/U (WR112)	Includes UG-51/U and UG-52B/U.
UG-448/U	Series tee	RG-48/U (WR284)	Includes 3 UG-53/U.
UG-449/U	Shunt tee	RG-48/U (WR284)	Includes 3 UG-53/U.

TABLE 8. V. Rigid waveguide assemblies — Continued

Type	Functional description	For use with waveguide types	Engineering data
UG-450/U	Series tee	RG-49/U (WR187)	Includes 3 UG-149A/U.
UG-451/U	Shunt tee	RG-49/U (WR187)	Includes 3 UG-149A/U.
UG-452/U	Series tee	RG-50/U (WR137)	Includes 3 UG-344/U.
UG-453/U	Shunt tee	RG-50/U (WR137)	Includes 3 UG-344/U.
UG-454/U	Series tee	RG-51/U (WR112)	Includes 3 UG-51/U.
UG-455/U	Shunt tee	RG-51/U (WR112)	Includes 3 UG-51/U.
UG-456/U	Series tee	RG-52/U (WR90)	Includes 3 UG-39/U.
UG-457/U	Shunt	RG-52/U (WR90)	Includes 3 UG-39/U.
UG-458/U	Series tee	RG-91, 107/U (WR62)	Includes 3 UG-419/U.
UG-459/U	Shunt tee	RG-91, 107/U (WR62)	Includes 3 UG-419/U.
UG-460/U	Series tee	RG-53, 66/U (WR42)	Includes 3 UG-425/U.
UG-461/U	Shunt tee	RG-53, 66/U (WR42)	Includes 3 UG-425/U.
UG-462/U	Series tee	RG-96/U (WR28)	Includes 3 UG-381/U.
UG-463/U	Shunt tee	RG-96/U (WR28)	Includes 3 UG-381/U.
UG-467/U	Magic tee	RG-75/U (WR284)	Mates with UG-585/U.
UG-468/U	Magic tee	RG-95/U (WR187)	Mates with UG-406/U.
UG-469/U	Magic tee	RG-106/U (WR137)	Mates with UG-440/U.
UG-470/U	Magic tee	RG-68/U (WR112)	Mates with UG-137A/U.
UG-471/U	Magic tee	RG-67/U (WR90)	Mates with UG-136A/U.
UG-472/U	Magic tee	RG-91, 107/U (WR62)	Mates with UG-541/U.
UG-473/U	Magic tee	RG-53, 66/U (WR42)	Mates with UG-425/U.
UG-579/U	Series tee	RG-69/U (WR650)	Includes 3 UG-417/U.
UG-580/U	Shunt tee	RG-69/U (WR650)	Includes 3 UG-417/U.
UG-648/U	Series tee	RG-75/U (WR284)	Includes 3 UG-584/U.
UG-649/U	Shunt tee	RG-106/U (WR137)	Includes 3 UG-441/U.
UG-650/U	Series tee	RG-67/U (WR90)	Includes 3 UG-135/U.
UG-658/U	Series tee	RG-68/U (WR112)	Includes 3 UG-138/U.
UG-659/U	Shunt tee	RG-68/U (WR112)	Includes 3 UG-138/U.
UG-660/U	Shunt tee	RG-67/U (WR90)	Includes 3 UG-135/U.

MIL-HDBK-216
SECTION 8A
7 April 1967

TABLE 8. V. Rigid waveguide assemblies — Continued

Type	Functional description	For use with waveguide types	Engineering data
UG-712/U	9-inch radius, H-bend (90°)	RG-48/U (WR284)	Includes UG-53/U and UG-54B/U.
UG-713/U	6-inch radius, H-bend (90°)	RG-49/U (WR187)	Includes UG-149A/U and UG-148C/U.
UG-714/U	4-1/8 inch radius, H-bend (90°)	RG-50/U (WR137)	Includes UG-343B/U and UG-344/U.
UG-715/U	3-3/8 inch radius, H-bend (90°)	RG-51/U (WR112)	Includes UG-51/U and UG-52B/U.
UG-716/U	3-inch-radius, H-bend (90°)	RG-52/U (WR90)	Includes UG-39/U and UG-40B/U.
UG-717/U	1-5/16-inch radius, H-bend (90°)	RG-53/U (WR42)	Includes UG-595/U and UG-596A/U.
UG-718/U	1-5/16-inch radius, H-bend (90°)	RG-66/U (WR42)	Includes UG-595/U and UG-596A/U.
UG-719/U	3-inch-radius, H-bend (90°)	RG-67/U (WR90)	Includes UG-135/U and UG-136B/U.
UG-720/U	3-3/8-inch radius, H-bend (90°)	RG-68/U (WR112)	Includes UG-137B/U and UG-138/U.
UG-721/U	9-inch radius, H-bend (90°)	RG-75/U (WR84)	Includes UG-584/U and UG-585A/U.
UG-722/U	2-7/64-inch radius, H-bend (90°)	RG-91/U (WR62)	Includes UG-419/U and UG-541A/U.
UG-723/U	6-inch radius, H-bend (90°)	RG-95/U (WR187)	Includes UG-406B/U and UG-407/U.
UG-724/U	1-5/16-inch radius, H-bend (90°)	RG-96/U (WR28)	Includes UG-599/U and UG-600A/U.
UG-725/U	4-1/8-inch radius, H-bend (90°)	RG-106/U (WR137)	Includes UG-440B/U and UG-441/U.
UG-726/U	2-7/64-inch radius, H-bend (90°)	RG-107/U (WR62)	Includes UG-419/U and UG-541A/U.
UG-727/U	1-5/16-inch radius, H-bend (90°)	RG-121/U (WR42)	Includes UG-597/U and UG-598A/U.
UG-728/U	8-1/4 ± 1/8-inch radius, E-bend (45°)	RG-48/U (WR284)	Includes UG-53/U and UG-54B/U.
UG-729/U	5-1/2 ± 1/8-inch radius, E-bend (45°)	RG-49/U (WR187)	Includes UG-148C/U and UG-149A/U.
UG-730/U	3-3/4 ± 1/8-inch radius, E-bend (45°)	RG-50/U (WR137)	Includes UG-343B/U and UG-344/U.

TABLE 8. V. Rigid waveguide assemblies — Continued

Type	Functional description	For use with waveguide types	Engineering data
UG-731/U	3-1/16 ± 1/16-inch radius, E-bend (45°)	RG-51/U (WR112)	Includes UG-51/U and UG-52B/U. Replaces UG-374A/U.
UG-732/U	2-3/4 ± 1/16-inch radius, E-bend (45°)	RG-52/U (WR90)	Includes UG-39/U and UG-40B/U.
UG-733/U	1-3/16 ± 1/16-inch radius, E-bend (45°)	RG-53/U (WR42)	Includes UG-595/U and UG-596A/U.
UG-734/U	1-3/16 ± 1/16-inch radius, E-bend (45°)	RG-66/U (WR42)	Includes UG-595/U and UG-596A/U.
UG-735/U	2-3/4 ± 1/16-inch radius, E-bend (45°)	RG-67/U (WR90)	Includes UG-135/U and UG-136B/U.
UG-736/U	3-1/6 ± 1/16-inch radius, E-bend (45°)	RG-68/U (WR112)	Includes UG-137B/U and UG-138/U.
UG-737/U	8-1/4 ± 1/8-inch radius, E-bend (45°)	RG-75/U (WR284)	Includes UG-584/U and UG-585A/U.
UG-738/U	1-15/16 ± 1/16-inch radius, E-bend (45°)	RG-91/U (WR62)	Includes UG-419/U and UG-541A/U.
UG-739/U	5-1/2 ± 1/8-inch radius, E-bend (45°)	RG-95/U (WR187)	Includes UG-406B/U and UG-407/U.
UG-740/U	55/64 ± 1/6-inch radius, E-bend (45°)	RG-96/U (WR28)	Includes UG-599/U and UG-600A/U.
UG-741/U	3-3/4 ± 1/8-inch radius, E-bend (45°)	RG-106/U (WR137)	Includes UG-440B/U and UG-441/U.
UG-742/U	1-15/16 ± 1/16-inch radius, E-bend (45°)	RG-107/U (WR62)	Includes UG-419/U and UG-541A/U.
UG-743/U	1-3/16 ± 1/16-inch radius, E-bend (45°)	RG-121/U (WR42)	Includes UG-597/U and UG-598A/U.
UG-744/U	60° Corner $\frac{1}{2}$ (E-plane)	RG-48/U (WR284)	Includes UG-53/U and UG-54B/U.
UG-745/U	60° Corner $\frac{1}{2}$ (E-plane)	RG-49/U (WR187)	Includes UG-148C/U and UG-149A/U.
UG-746/U	60° Corner $\frac{1}{2}$ (E-plane)	RG-50/U (WR137)	Includes UG-343B/U and UG-344/U.
UG-747/U	60° Corner $\frac{1}{2}$ (E-plane)	RG-51/U (WR112)	Includes UG-51/U and UG-52B/U.
UG-748/U	60° Corner $\frac{1}{2}$ (E-plane)	RG-52/U (WR90)	Includes UG-39/U and UG-40B/U.
*UG-749/U	60° Corner $\frac{1}{2}$ (E-plane)	RG-53/U (WR42)	Includes UG-595/U and UG-596A/U.

See footnotes at end of table.

MIL-HDBK-216
SECTION 8 A
7 April 1967

TABLE 8. V. Rigid waveguide assemblies. — Continued

Type	Functional description	For use with waveguide types	Engineering data
UG-750/U	60° Corner $\frac{1}{2}$ (E-plane)	RG-66/U (WR42)	Includes UG-595/U and UG-596A/U.
UG-751/U	60° Corner $\frac{1}{2}$ (E-plane)	RG-67/U (WR90)	Includes UG-135/U and UG-136B/U.
UG-752/U	60° Corner $\frac{1}{2}$ (E-plane)	RG-68/U (WR112)	Includes UG-137B/U and UG-138/U.
UG-753/U	60° Corner $\frac{1}{2}$ (E-plane)	RG-75/U (WR284)	Includes UG-584/U and UG-585A/U.
UG-754/U	60° Corner $\frac{1}{2}$ (E-plane)	RG-91/U (WR62)	Includes UG-419/U and UG-541A/U.
UG-755/U	60° Corner $\frac{1}{2}$ (E-plane)	RG-95/U (WR187)	Includes UG-406B/U and UG-407/U.
UG-756/U	60° Corner $\frac{1}{2}$ (E-plane)	RG-96/U (WR28)	Includes UG-599/U and UG-600A/U.
UG-757/U	60° Corner $\frac{1}{2}$ (E-plane)	RG-106/U (WR137)	Includes UG-440B/U and UG-441/U.
UG-758/U	60° Corner $\frac{1}{2}$ (E-plane)	RG-107/U (WR62)	Includes UG-419/U and UG-541A/U.
UG-759/U	60° Corner $\frac{1}{2}$ (E-plane)	RG-121/U (WR42)	Includes UG-597/U and UG-598A/U.
UG-760/U	45° Corner $\frac{1}{2}$ (E-plane)	RG-48/U (WR284)	Includes UG-53/U and UG-54B/U.
UG-761/U	45° Corner $\frac{1}{2}$ (E-plane)	RG-49/U (WR187)	Includes UG-148C/U and UG-149A/U.
UG-762/U	45° Corner $\frac{1}{2}$ (E-plane)	RG-50/U (WR137)	Includes UG-343B/U and UG-344/U.
UG-763/U	45° Corner $\frac{1}{2}$ (E-plane)	RG-51/U (WR112)	Includes UG-51/U and UG-52B/U.
UG-764/U	45° Corner $\frac{1}{2}$ (E-plane)	RG-52/U (WR90)	Includes UG-39/U and UG-40B/U.
UG-765/U	45° Corner $\frac{1}{2}$ (E-plane)	RG-53/U (WR42)	Includes UG-595/U and UG-596A/U.
UG-766/U	45° Corner $\frac{1}{2}$ (E-plane)	RG-66/U (WR42)	Includes UG-595/U and UG-596A/U.
UG-767/U	45° Corner $\frac{1}{2}$ (E-plane)	RG-67/U (WR90)	Includes UG-135/U and UG-136B/U.
UG-768/U	45° Corner $\frac{1}{2}$ (E-plane)	RG-68/U (WR112)	Includes UG-137B/U and UG-138/U.

See footnotes at end of table.

TABLE 8. V. Rigid waveguide assemblies. — Continued

Type	Functional description.	For use with waveguide types	Engineering data
UG-769/U	45° Corner $\frac{1}{2}$ (E-plane)	RG-75/U (WR284)	Includes UG-584/U and UG-585A/U.
UG-770/U	45° Corner $\frac{1}{2}$ (E-plane)	RG-91/U (WR62)	Includes UG-419/U and UG-541A/U.
UG-771/U	45° Corner $\frac{1}{2}$ (E-plane)	RG-95/U (WR187)	Includes UG-406B/U and UG-407/U.
UG-772/U	45° Corner $\frac{1}{2}$ (E-plane)	RG-96/U (WR28)	Includes UG-599/U and UG-600A/U.
UG-773/U	45° Corner $\frac{1}{2}$ (E-plane)	RG-106/U (WR137)	Includes UG-440B/U and UG-441/U.
UG-774/U	45° Corner $\frac{1}{2}$ (E-plane)	RG-107/U (WR62)	Includes UG-419/U and UG-541A/U.
UG-775/U	45° Corner $\frac{1}{2}$ (E-plane)	RG-121/U (WR42)	Includes UG-597/U and UG-598A/U.
UG-776/U	9-inch radius, H-bend (45°)	RG-48/U (WR284)	Includes UG-53/U and UG-54B/U.
UG-777/U	6-inch radius, H-bend (45°)	RG-49/U (WR187)	Includes UG-148C/U and UG-149A/U.
UG-778/U	4-1/8-inch radius, H-bend (45°)	RG-50/U (WR137)	Includes UG-343B/U and UG-344/U.
UG-779/U	2-3/4-inch radius, H-bend (45°)	RG-51/U (WR112)	Includes UG-51/U and UG-52B/U.
UG-780/U	3-inch radius, H-bend (45°)	RG-52/U (WR90)	Includes UG-39/U and UG-40B/U.
UG-781/U	1-5/16-inch radius, H-bend (45°)	RG-53/U (WR42)	Includes UG-595/U and UG-596A/U.
UG-782/U	1-5/16-inch radius, H-bend (45°)	RG-66/U (WR42)	Includes UG-595/U and UG-596A/U.
UG-783/U	3-inch radius, H-bend (45°)	RG-67/U (WR90)	Includes UG-135/U and UG-136B/U.
UG-784/U	3-3/8-inch radius, H-bend (45°)	RG-68/U (WR112)	Includes UG-137B/U and UG-138/U.
UG-785/U	9-inch radius, H-bend (45°)	RG-75/U (WR284)	Includes UG-584/U and UG-585A/U.
UG-786/U	2-7/64-inch radius, H-bend (45°)	RG-91/U (WR62)	Includes UG-419/U and UG-541A/U.
UG-787/U	6-inch radius, H-bend (45°)	RG-95/U (WR187)	Includes UG-406B/U and UB-407/U.
UG-788/U	23/25-inch radius, H-bend (45°)	RG-96/U (WR28)	Includes UG-599/U and UG-600A/U.

See footnotes at end of table.

MIL-HDBK-216
SECTION 8A
7 April 1967

TABLE 8. V. Rigid waveguide assemblies - Continued

Type	Functional description	For use with waveguide types	Engineering data
UG-789/U	4-1/8-inch radius, H-bend (45°)	RG-106/U (WR137)	Includes UG-440B/U and UG-441/U.
UG-790/U	2-7/64-inch radius, H-bend (45°)	RG-107/U (WR62)	Includes UG-419/U and UG-541A/U.
UG-791/U	1-5/16-inch radius, H-bend (45°)	RG-121/U (WR42)	Includes UG-597/U and UG-598A/U.
UG-792/U	45° Corner 1/4 (H-bend)	RG-48/U (WR284)	Includes UG-53/U and UG-54B/U.
UG-793/U	45° Corner 1/4 (H-bend)	RG-49/U (WR187)	Includes UG-148C/U and UG-149A/U.
UG-794/U	45° Corner 1/4 (H-bend)	RG-50/U (WR137)	Includes UG-343B/U and UG-344/U.
UG-795/U	45° Corner 1/4 (H-plane)	RG-51/U (WR112)	Includes UG-51/U and UG-52B/U.
UG-796/U	45° Corner 1/4 (H-plane)	RG-52/U (WR90)	Includes UG-39/U and UG-40B/U.
UG-797/U	45° Corner 1/4 (H-bend)	RG-53/U (WR42)	Includes UG-595/U and UG-596A/U.
UG-798/U	45° Corner 1/4 (H-bend)	RG-66/U (WR42)	Includes UG-595/U and UG-596A/U.
UG-799/U	45° Corner 1/4 (H-bend)	RG-67/U (WR90)	Includes UG-135/U and UG-136B/U.
UG-800/U	45° Corner 1/4 (H-bend)	RG-68/U (WR112)	Includes UG-137B/U and UG-138/U.
UG-801/U	45° Corner 1/4 (H-plane)	RG-75/U (WR284)	Includes UG-584/U and UG-585A/U.
UG-802/U	45° Corner 1/4 (H-plane)	RG-91/U (WR62)	Includes UG-419/U and UG-541A/U.
UG-803/U	45° Corner 1/4 (H-plane)	RG-95/U (WR187)	Includes UG-506B/U and UG-407/U.
UG-804/U	45° Corner 1/4 (H-plane)	RG-96/U (WR28)	Includes UG-599/U and UG-600A/U.
UG-805/U	45° Corner 1/4 (H-plane)	RG-106/U (WR137)	Includes UG-440B/U and UG-441/U.
UG-806/U	45° Corner 1/4 (H-plane)	RG-107/U (WR62)	Includes UG-419/U and UG-541A/U.
UG-807/U	45° Corner 1/4 (H-plane)	RG-121/U (WR42)	Includes UG-597/U and UG-598A/U.
UG-808/U	9-inch radius, H-bend (60°)	RG-48/U (WR284)	Includes UG-53/U and UG-54B/U.

See footnotes at end of table.

TABLE 8. V. Rigid waveguide assemblies -- Continued

Type	Functional description	For use with waveguide types	Engineering data
UG-809/U	6-inch radius, H-bend (60°)	RG-49/U (WR187)	Includes UG-148C/U and UG-149A/U
UG-810/U	4-1/8-inch radius, H-bend (60°)	RG-50/U (WR137)	Includes UG-343B/U and UG-344/U.
UG-811/U	3-3/8-inch radius, H-bend (60°)	RG-51/U (WR112)	Includes UG-51/U and UG-52B/U. Replaces UG-373/U.
UG-812/U	3-inch radius, H-bend (60°)	RG-52/U (WR90)	Includes UG-39/U and UG-40B/U.
UG-813/U	1-5/16-inch radius, H-bend (60°)	RG-53/U (WR42)	Includes UG-595/U and UG-596A/U.
UG-814/U	1-5/16-inch radius, H-bend (60°)	RG-66/U (WR42)	Includes UG-595/U and UG-596A/U.
UG-815/U	3-inch radius, H-bend (60°)	RG-67/U (WR90)	Includes UG-135/U and UG-136B/U.
UG-816/U	3-3/8-inch radius, H-bend (60°)	RG-68/U (WR112)	Includes UG-137B/U and UG-138/U.
UG-817/U	9-inch radius, H-bend (60°)	RG-75/U (WR284)	Includes UG-584/U and UG-585A/U.
UG-818/U	2-7/64-inch radius, H-bend (60°)	RG-91/U (WR62)	Includes UG-419/U and UG-541A/U.
UG-819/U	6-inch radius, H-bend (60°)	RG-95/U (WR187)	Includes UG-406B/U and UG-407/U.
UG-820/U	15/16-inch radius, H-bend (60°)	RG-96/U (WR28)	Includes UG-599/U and UG-600A/U.
UG-821/U	4-1/8-inch radius, H-bend (60°)	RG-106/U (WR137)	Includes UG-440B/U and UG-441/U.
UG-822/U	2-7/64-inch radius, H-bend (60°)	RG-107/U (WR62)	Includes UG-419/U and UG-541A/U.
UG-823/U	1-5/16-inch radius, H-bend (60°)	RG-121/U (WR42)	Includes UG-597/U and UG-598A/U.
UG-824/U	8-1/4-inch radius, E-bend (60°)	RG-48/U (WR284)	Includes UG-53/U and UG-54B/U.
UG-825/U	5-1/2-inch radius, E-bend (60°)	RG-49/U (WR187)	Includes UG-148C/U and UG-149A/U.
UG-826/U	3-3/4-inch radius, E-bend (60°)	RG-50/U (WR137)	Includes UG-343B/U and UG-344/U.
UG-827/U	3-1/16-inch radius, E-bend (60°)	RG-51/U (WR112)	Includes UG-51/U and UG-52B/U. Replaces UG-375/U.

MIL-HDBK-216
SECTION 8 A
7 April 1967

TABLE 8. V. Rigid waveguide assemblies — Continued

Type	Functional description	For use with waveguide types	Engineering data
UG-828/U	2-3/4-inch radius, E-bend (60°)	RG-52/U (WR90)	Includes UG-39/U and UG-40B/U.
UG-829/U	1-3/16-inch radius, E-bend (60°)	RG-53/U (WR42)	Includes UG-595/U and UG-596A/U.
UG-830/U	1-3/16-inch radius, E-bend (60°)	RG-66/U (WR42)	Includes UG-595/U and UG-596A/U.
UG-831/U	2-3/4-inch radius, E-bend (60°)	RG-67/U (WR90)	Includes UG135/U and UG-136B/U.
UG-832/U	3-1/16-inch radius, E-bend (60°)	RG-68/U (WR112)	Includes UG-137B/U and UG-138/U.
UG-833/U	8-1/4-inch radius, E-bend (60°)	RG-75/U (WR284)	Includes UG-584/U and UG-585A/U.
UG-834/U	1-15/16-inch radius, E-bend (60°)	RG-91/U (WR62)	Includes UG-419/U and UG-541A/U.
UG-835/U	5-1/2-inch radius, E-bend (60°)	RG-95/U (WR187)	Includes UG-406B/U and UG-407/U.
UG-836/U	55/64-inch radius, E-bend (60°)	RG-96/U (WR28)	Includes UG-599/U and UG-600A/U.
UG-837/U	3-3/4-inch radius, E-bend (60°)	RG-106/U (WR137)	Includes UG-440B/U and UG-441/U.
UG-838/U	1-15/16-inch radius, E-bend (60°)	RG-107/U (WR62)	Includes UG-419/U and UG-541A/U.
UG-839/U	1-3/16-inch radius, E-bend (60°)	RG-121/U (WR42)	Includes UG-597/U and UG-598A/U.
UG-844/U	90° Corner 2/ (H-plane)	RG-48/U (WR284)	Includes UG-53/U and UG-54B/U.
UG-845/U	90° Corner 2/ (H-plane)	RG-49/U (WR187)	Includes UG-148C/U and UG-149A/U.
UG-846/U	90° Corner 2/ (H-plane)	RG-50/U (WR137)	Includes UG-343B/U and UG-344/U.
UG-847/U	90° Corner 2/ (H-plane)	RG-51/U (WR112)	Includes UG-51/U and UG-52B/U.
UG-848/U	90° Corner 2/ (H-plane)	RG-52/U (WR90)	Includes UG-39/U and UG-40B/U.
UG-849/U	90° Corner 2/ (H-plane)	RG-53/U (WR42)	Includes UG-595/U and UG-596A/U.
UG-850/U	90° Corner 2/ (H-plane)	RG-66/U (WR42)	Includes UG-595/U and UG-596A/U.

See footnotes at end of table.

TABLE 8. V. Rigid waveguide assemblies. — Continued

Type	Functional description	For use with waveguide types	Engineering data
UG-851/U	90° Corner $\frac{2}{2}$ / (H-plane)	RG-67/U (WR90)	Includes UG-135/U and UG-136B/U.
UG-852/U	90° Corner $\frac{2}{2}$ / (H-plane)	RG-68/U (WR112)	Includes UG-137B/U and UG-138/U.
UG-853/U	90° Corner $\frac{2}{2}$ / (H-plane)	RG-75/U (WR284)	Includes UG-584/U and UG-585A/U.
UG-854/U	90° Corner $\frac{2}{2}$ / (H-plane)	RG-91/U (WR62)	Includes UG-419/U and UG-541A/U.
UG-855/U	90° Corner $\frac{2}{2}$ / (H-plane)	RG-95/U (WR187)	Includes UG-406B/U and UG-407/U.
UG-856/U	90° Corner $\frac{2}{2}$ / (H-plane)	RG-96/U (WR28)	Includes UG-599/U and UG-600A/U.
UG-857/U	90° Corner $\frac{2}{2}$ / (H-plane)	RG-106/U (WR137)	Includes UG-440B/U and UG-441/U.
UG-858/U	90° Corner $\frac{2}{2}$ / (H-plane)	RG-107/U (WR62)	Includes UG-419/U and UG-541A/U.
UG-859/U	90° Corner $\frac{2}{2}$ / (H-plane)	RG-121/U (WR42)	Includes UG-597/U and UG-598A/U.
UG-860/U	8-1/4-inch radius, E-bend (90°)	RG-48/U (WR284)	Includes UG-53/U and UG-54B/U.
UG-861/U	5-1/2-inch radius, E-bend (90°)	RG-49/U (WR187)	Includes UG-148C/U and UG-149A/U.
UG-862/U	3-3/4-inch radius, E-bend (90°)	RG-50/U (WR137)	Includes UG-343B/U and UG-344/U.
UG-863/U	3-1/16-inch radius, E-bend (90°)	RG-51/U (WR-112)	Includes UG-51/U and UG-52B/U. Replaces UG-142/U and UG-378/U
UG-864/U	2-3/4-inch radius, E-bend (90°)	RG-52/U (WR90)	Includes UG-39/U and UG-40B/U.
UG-865/U	1-3/16-inch radius, E-bend (90°)	RG-53/U (WR42)	Includes UG-595/U and UG-596A/U.
UG-866/U	1-3/16-inch radius, E-bend (90°)	RG-66/U (WR42)	Includes UG-595/U and UG-596A/U.
UG-867/U	2-3/4-inch radius, E-bend (90°)	RG-67/U (WR90)	Includes UG-135/U and UG-136B/U.
UG-868/U	3-1/16-inch radius, E-bend (90°)	RG-68/U (WR112)	Includes UG-137B/U and UG-138/U.
UG-869/U	8-1/4-inch radius, E-bend (90°)	RG-75/U (WR284)	Includes UG-584/U and UG-585A/U.

See footnotes at end of table.

MIL-HDBK-216
SECTION 8 A
7 April 1967

TABLE 8. V. Rigid waveguide assemblies -- Continued

Type	Functional description	For use with waveguide types	Engineering data
UG-870/U	1-15/16-inch radius, E-bend (90°)	RG-91/U (WR62)	Includes UG-419/U and UG-541A/U.
UG-871/U	5-1/2-inch radius, E-bend (90°)	RG-95/U (WR187)	Includes UG-406B/U and UG-407/U.
UG-872/U	55/64-inch radius, E-bend (90°)	RG-96/U (WR28)	Includes UG-599/U and UG-600A/U.
UG-873/U	3-3/4-inch radius, E-bend (90°)	RG-106/U (WR137)	Includes UG-440B/U and UG-441/U.
UG-874/U	1-15/16-inch radius, E-bend (90°)	RG-107/U (WR62)	Includes UG-419/U and UG-541A/U.
UG-875/U	1-3/16-inch radius, E-bend (90°)	RG-121/U (WR42)	Includes UG-597/U and UG-598A/U.
UG-877/U	60° Corner $\frac{1}{2}$ (H-plane)	RG-48/U (WR284)	Includes UG-53/U and UG-54B/U.
UG-878/U	60° Corner $\frac{1}{2}$ (H-plane)	RG-49/U (WR187)	Includes UG-148C/U and UG-149A/U.
UG-879/U	60° Corner $\frac{1}{2}$ (H-plane)	RG-50/U (WR137)	Includes UG-343B/U and UG-344/U.
UG-880/U	60° Corner $\frac{1}{2}$ (H-plane)	RG-51/U (WR112)	Includes UG-51/U and UG-52B/U.
UG-881/U	60° Corner $\frac{1}{2}$ (H-plane)	RG-52/U (WR90)	Includes UG-39/U and UG-40B/U.
UG-882/U	60° Corner $\frac{1}{2}$ (H-plane)	RG-53/U (WR42)	Includes UG-595/U and UG-596A/U.
UG-883/U	60° Corner $\frac{1}{2}$ (H-plane)	RG-67/U (WR90)	Includes UG-135/U and UG-136B/U.
UG-884/U	60° Corner $\frac{1}{2}$ (H-plane)	RG-68/U (WR112)	Includes UG-137B/U and UG-138/U.
UG-885/U	60° Corner $\frac{1}{2}$ (H-plane)	RG-75/U (WR284)	Includes UG-584/U and UG-585A/U.
UG-886/U	60° Corner $\frac{1}{2}$ (H-plane)	RG-91/U (WR62)	Includes UG-419/U and UG-541A/U.
UG-887/U	60° Corner $\frac{1}{2}$ (H-plane)	RG-95/U (WR187)	Includes UG-406B/U and UG-407/U.
UG-888/U	60° Corner $\frac{1}{2}$ (H-plane)	RG-96/U (WR28)	Includes UG-599/U and UG-600A/U.
UG-889/U	60° Corner $\frac{1}{2}$ (H-plane)	RG-106/U (WR137)	Includes UG-440B/U and UG-441/U.

See footnotes at end of table.

TABLE 8. V. Rigid waveguide assemblies -- Continued

Type	Functional description	For use with waveguide types	Engineering data
UG-890/U	60° Corner $\frac{1}{2}$ / (H-plane)	RG-107/U (WR62)	Includes UG-419/U and UG-541A/U.
UG-891/U	60° Corner $\frac{1}{2}$ / (H-plane)	RG-121/U (WR42)	Includes UG-597/U and UG-598A/U.
UG-892/U	60° Corner $\frac{1}{2}$ / (H-plane)	RG-66/U (WR42)	Includes UG-595/U and UG-596A/U.
UG-893/U	90° Corner $\frac{2}{2}$ / (E-plane)	RG-48/U (WR284)	Includes UG-53/U and UG-54B/U.
UG-894/U	90° Corner $\frac{2}{2}$ / (E-plane)	RG-49/U (WR187)	Includes UG-148C/U and UG-149A/U.
UG-895/U	90° Corner $\frac{2}{2}$ / (E-plane)	RG-50/U (WR137)	Includes UG-343B/U and UG-344/U.
UG-896/U	90° Corner $\frac{2}{2}$ / (E-plane)	RG-51/U (WR112)	Includes UG-51/U and UG-52B/U.
UG-897/U	90° Corner $\frac{2}{2}$ / (E-plane)	RG-52/U (WR90)	Includes UG-39/U and UG-40B/U.
UG-898/U	90° Corner $\frac{2}{2}$ / (E-plane)	RG-53/U (WR42)	Includes UG-595/U and UG-596A/U.
UG-899/U	90° Corner $\frac{2}{2}$ / (E-plane)	RG-66/U (WR42)	Includes UG-595/U and UG-596A/U.
UG-900/U	90° Corner $\frac{2}{2}$ / (E-plane)	RG-67/U (WR90)	Includes UG-135/U and UG-136B/U.
UG-901/U	90° Corner $\frac{2}{2}$ / (E-plane)	RG-68/U (WR112)	Includes UG-137B/U and UG-138/U.
UG-902/U	90° Corner $\frac{2}{2}$ / (E-plane)	RG-75/U (WR284)	Includes UG-584/U and UG-585A/U.
UG-903/U	90° Corner $\frac{2}{2}$ / (E-plane)	RG-91/U (WR62)	Includes UG-419/U and UG-541A/U.
UG-904/U	90° Corner $\frac{2}{2}$ / (E-plane)	RG-95/U (WR187)	Includes UG-406B/U and UG-407/U.
UG-905/U	90° Corner $\frac{2}{2}$ / (E-plane)	RG-96/U (WR28)	Includes UG-599/U and UG-600A/U.
UG-906/U	90° Corner $\frac{2}{2}$ / (E-plane)	RG-106/U (WR137)	Includes UG-440B/U and UG-441/U.
UG-907/U	90° Corner $\frac{2}{2}$ / (E-plane)	RG-107/U (WR62)	Includes UG-419/U and UG-541A/U.
UG-908/U	90° Corner $\frac{2}{2}$ / (E-plane)	RG-121/U (WR42)	Includes UG-597/U and UG-598A/U.

See footnotes at end of table

MIL-HDBK-216
SECTION 8A
7 April 1967

TABLE 8. V. Rigid waveguide assemblies — Continued

Type	Functional description	For use with waveguide types	Engineering data
UG-955/U	45° Corner 2/ (H-plane)	RG-69/U (WR650)	Includes 2 UG-954/U.
UG-956/U	90° Corner 2/ (E-plane)	RG-69/U (WR650)	Includes 2 UG-954/U.
UG-957/U	45° Corner 2/ (E-plane)	RG-69/U (WR650)	Includes 2 UG-954/U.
UG-958/U	90° Corner 2/ (H-plane)	RG-69/U (WR650)	Includes 2 UG-954/U.
UG-962/ FPS-8	7-1/4-inch radius, E-bend (90°)	RG-103/U (WR650)	Includes 2 UG-418A/U.
UG-963/ FPS-8	7-1/4-inch radius, E-bend (90°)	RG-69/U (WR650)	Includes 2 UG-417A/U.
UG-973/U	6-inch radius, E-bend (90°)	RG-110/U (WR137)	Includes UG-511/U and UG-512/U.
UG-974/U	12-inch radius, E-bend (90°)	RG-109/U	Includes UG-509/U and UG-510/U.
UG-990/U	90° bend	RG-69/U (WR650)	Includes flanges similar to UG-417A/U.
UG-991/U	90° bend	RG-69/U (WR650)	Includes flanges similar to UG-417A/U.
UG-996/U	Adapter	RG-48/U (WR284) RG-109/U	Transition: Includes UG-509/U and UG-65/U.
UG-1042/U	Magic tee	RG-48/U (WR284)	Mates with UG-54A/U.
UG-1043/U	Magic tee	RG-49/U (WR187)	Mates with UG-148C/U.
UG-1044/U	Magic tee	RG-50/U (WR137)	Mates with UG-343B/U.
UG-1045/U	Magic tee	RG-51/U (WR112)	Mates with UG-52B/U.
UG-1046/U	Magic tee	RG-52/U (WR90)	Mates with UG-40B/U.
UG-1070/U	Rotary coupler		
UG-1071/U	2-inch radius, E-bend (90°)	RG-51/U (WR112) RG-66/U	Includes UG-137B/U and UG-138/U.
UG-1072/U	2.38-inch radius, 45° bend	RG-68/U (WR112)	Includes UG-137B/U and UG-138/U.
UG-1077/U	Magic tee	RG-53/U (WR42) RG-66/U	Mates with UG-596A/U.
UG-1078/U	Magic tee	RG-96/U (WR28)	Mates with UG-600A/U.
UG-1088/U	1/4-inch radius, E-bend (90°)	RG-52/U (WR90)	Includes 2 UG-39/U.

See footnotes at end of table

TABLE 8. V. Rigid waveguide assemblies — Continued

Type	Functional description	For use with waveguide types	Engineering data
UG-1089/U	1/16-inch radius, H-bend (90°)	RG-52/U (WR90)	Includes 2 UG-39/U.
CG-345/U	1.27-inch radius, E-bend (90°)	RG-53/U (WR42) RG-66/U	Includes UG-116/U and UG-117/U.
CG-346/U	1.75-inch radius, H-bend (90°)	RG-53/U (WR42) RG-66/U	Includes UG-116/U and UG-117/U.
CG-471A/U	90° Twist	RG-51/U (WR112)	Includes UG-51/U and UG-52B/U.
CG-472A/U	Straight	RG-51/U (WR112)	Includes UG-51/U and UG-52B/U.
CG-473/U	Adapter 2-1/2 inch straight	RG-51/U (WR112)	Includes 2 UG-51/U.
CG-474/U	Adapter 2-1/2 inch straight	RG-51/U (WR112)	Includes 2 UG-52B/U.
CG-475/U	Straight (pressure section)	RG-51/U (WR112)	Includes UG-51/U and UG-52B/U.
CG-495/U	3. inch radius, E-bend (90°)	RG-51/U (WR112)	Replaced by UG-863/U.
CG-496/U	3-inch radius, E-bend (90°)	RG-52/U (WR90)	Replaced by UG-864/U.
CG-501/U	Straight	RG-96/U (WR28)	Includes 2 UG-383/U.
CG-502/U	Straight	RG-97/U (WR22)	Includes 2 UG-383/U.
CG-503/U	Straight	RG-98/U (WR15)	Includes 2 UG-365/U.
CG-504/U	Straight	RG-99/U (WR12)	Includes 2 UG-387/U.
CG-517/U	Straight	RG-53/U (WR42)	Includes 2 UG-425/U.
CG-518/U	Straight	RG-66/U (WR42)	Includes 2 UG-425/U.
CG-575/U	Straight	RG-50/U (WR137)	Includes UG-150/U and UG-247/U.
CG-637/U	Straight	RG-69/U (WR650)	Includes 2 UG-417A/U.
CG-639/U	Straight	RG-103/U (WR650)	Includes 2 UG-418A/U.
CG-844/U	Straight	RG-50/U (WR137)	Includes UG-343B/U and UG-344/U.
CG-942/U	Straight	RG-75/U (WR284)	Includes 2 UG-585A/U.
CG-946/U	Straight	RG-75/U (WR284)	Includes UG-584/U and UG-585A/U.
CG-962/U	Straight	RG-103/U (WR650)	Includes 2 UG-418A/U.
CG-970/U	Straight	RG-109/U	Includes 1 UG-509/U.
CG-971/U	Straight	RG-110/U	Includes UG-511/U and UG-512/U.

MIL-HDBK-216
SECTION 8 A
7 April 1967

TABLE 8. V. Rigid waveguide assemblies -- Continued

Type	Functional description	For use with waveguide types	Engineering data
CG-972/U	90° twist	RG-110/U	Includes UG-511/U and UG-512/U.
CG-973/U	90° twist	RG-109/U	Includes UG-509/U and UG-510/U.
CG-980/U	90° twist	RG-50/U (WR137)	Includes UG-343B/U and UG-344/U 7.750-inch length overall.
CG-981/U	90° twist	RG-106/U	Includes UG-440B/U and UG-441/U 7.750-inch length overall.
CG-982/U	90° twist	RG-51/U (WR112)	Includes UG-51/U and UG-52B/U 6.500-inch length overall.
CG-983/U	90° twist	RG-68/U (WR112)	Includes UG-137B/U and UG-138/U 6.500-inch length overall.
CG-984/U	90° twist	RG-52/U (WR90)	Includes UG-39/U and UG-40B/U 5.250-inch length overall.
CG-985/U	90° twist	RG-67/U (WR90)	Includes UG-135/U and UG-136B/U 5.250-inch length overall.
CG-986/U	90° twist	RG-91/U (WR62)	Includes UG-419/U and UG-541A/U 3.125-inch length overall.
CG-987/U	90° twist	RG-107/U (WR62)	Includes UG-419/U and UG-541A/U 3.125-inch length overall.
CG-988/U	90° twist	RG-53/U (WR42)	Includes UG-595/U and UG-596A/U 2.563-inch length overall.
CG-989/U	90° twist	RG-66/U (WR42)	Includes UG-595/U and UG-596A/U 2.563-inch length overall.
CG-990/U	90° twist	RG-96/U (WR28)	Includes UG-599/U and UG-600A/U 1.813-inch length overall.
CG-991/U	90° twist	RG-121/U (WR42)	Includes UG-597/U and UG-598A/U 2.563-inch length overall.
CG-992/U	90° twist	RG-48/U (WR284)	Includes UG-53/U and UG-54B/U 15.500-inch length overall.
CG-993/U	90° twist	RG-75/U (WR284)	Includes UG-584/U and UG-585A/U 15.500-inch length overall.
CG-994/U	90° twist	RG-49/U (WR187)	Includes UG-148C/U and UG-149A/U 10.250-inch length overall.
CG-995/U	90° twist	RG-95/U (WR187)	Includes UG-406B/U and UG-407/U 10.250-inch length overall.
CG-1010/U	Straight	RG-103/U (WR650)	Includes 2 UG-418A/U.
CG-1049/U	Straight	Navy type 14ACM	Includes UG-368/U and UG-369/U.
CG-1050/U	Straight	Navy type 14ACM	Includes 1 UG-369/U.

TABLE 8. V. Rigid waveguide assemblies — Continued

Type	Functional description	For use with waveguide types	Engineering data
CG-1051/U	Straight	Navy type 14ACM	Includes UG-368/U.
CG-1117/U	Series tee	RG-95/U (WR187)	Includes 3 UG-407/U.
CG-1118/U	Series tee	RG-106/U (WR137)	Includes 3 UG-441/U.
CG-1119/U	Series tee	RG-53/U (WR42)	Includes 3 UG-595/U.
CG-1120/U	Series tee	RG-96/U (WR28)	Includes 3 UG-599/U.
CG-1121/U	Shunt tee	RG-75/U (WR284)	Includes 3 UG-584/U.
CG-1122/U	Shunt tee	RG-95/U (WR187)	Includes 3 UG-407/U.
CG-1123/U	Shunt tee	RG-53/U (WR42)	Includes 3 UG-595/U.
CG-1124/U	Shunt tee	RG-96/U (WR28)	Includes 3 UG-599/U.
CCG-1128/U	90° step twist	RG-112/U (WR340)	Two cover flanges equiv. to UG-553/U; 5.865-inch length overall.
CG-1129/U	90° step twist	RG-113/U (WR340)	Two cover flanges equiv. to UG-554/U; 5.865-inch length overall.
CG-1130/U	90° step twist	RG-69/U (WR650)	Two cover flanges equiv. to UG-417A/U; 11.716-inch length overall.
CG-1131/U	90° step twist	RG-103/U (WR650)	Two cover flanges equiv. to UG-418A/U; 11.716-inch length overall.
CG-1132/U	90° step twist	RG-104/U (WR430)	Two cover flanges equiv. to UG-435A/U; 7.419-inch length overall.
CG-1133/U	90° step twist	RG-105/U (WR430)	Two cover flanges equiv. to UG-437A/U; 7.419-inch length overall.
CG-1134/U	90° step twist	RG-53/U (WR42) RG-66/U	One flange equiv. to UG-595/U, other equiv. to UG-596/U; 0.729-inch length overall.
CG-1135/U	90° step twist	RG-121/U (WR42)	One flange equiv. to UG-598/U, other equiv. to UG-597/U; 0.729-inch length overall.
CG-1136/U	90° step twist	RG-51/U (WR112)	One flange equiv. to UG-52B/U, other equiv. to UG-51/U; 1.953-inch length overall.
CG-1137/U	90° step twist	RG-68/U (WR112)	One flange equiv. to UG-137B/U, other equiv. to UG-138/U; 1.953-inch length overall.

MIL-HDBK-216
SECTION 8A
7 April 1967

TABLE 8. V. Rigid waveguide assemblies — Continued

Type	Functional description	For use with waveguide types	Engineering data
CG-1138/U	90° step twist	RG-52/U (WR90)	One flange equiv. to UG-40B/U, other equiv. to UG-39/U; 1.566-inch length overall.
CG-1139/U	90° step twist	RG-67/U (WR90)	One flange equiv. to UG-136B/U, other equiv. to UG-135/U; 1.566-inch length overall.
CG-1140/U	90° step twist	RG-50/U (WR137)	One flange equiv. to UG-343A/U, other equiv. to UG-344/U; 2.384-inch length overall.
CG-1141/U	90° step twist	RG-106/U (WR137)	One flange equiv. to UG-440B/U, other equiv. to UG-441/U; 2.384-inch length overall.
CG-1142/U	90° step twist	RG-48/U (WR284)	One flange equiv. to UG-54B/U, other equiv. to UG-53/U; 4.936-inch length overall.
CG-1143/U	90° step twist	RG-75/U (WR284)	One flange equiv. to UG-585A/U, other equiv. to UG-584/U; 4.936-inch length overall.
CG-1144/U	90° step twist	RG-49/U (WR187)	One flange equiv. to UG-148C/U, other equiv. to UG-149A/U; 3.255-inch length overall.
CG-1145/U	90° step twist	RG-95/U (WR187)	One flange equiv. to UG-406B/U, other equiv. to UG-407/U; 3.255-inch length overall.
CG-1146/U	90° step twist	RG-96/U (WR28)	One flange equiv. to UG-600A/U, other equiv. to UG-599/U; 0.485-inch length overall.
CG-1147/U	90° step twist	RG-91/U (WR62) RG-107/U	One flange equiv. to UG-541A/U, other equiv. to UG-419/U; 1.079-inch length overall.
CG-1148/U	-90° to +90° Rotary step twist	RG-95/U (WR187)	One flange equiv. to UG-406B/U, other equiv. to UG-407/U; 4.020-inch length overall.
CG-1149/U	-90° to +90° Rotary step twist	RG-95/U (WR187)	One flange equiv. to UG-406B/U, other equiv. to UG-407/U; 4.020-inch length overall.
CG-1150/U	-90° to +90° Rotary step twist	RG-52/U (WR90)	One flange equiv. to UG-40B/U, other equiv. to UG-39/U; 2.097-inch length overall.
CG-1151/U	-90° to +90° Rotary step twist	RG-67/U (WR90)	One flange equiv. to UG-136B/U, other equiv. to UG-135/U; 2.097-inch length overall.
CG-1163/U	Two 90° bends re- versing direction	RG-50/U (WR137)	Includes 2 UG-137B/U, at 9100 mc, VSWR is 1.10.

TABLE 8. V. Rigid waveguide assemblies. — Continued

Type	Functional description	For use with waveguide types	Engineering data
CG-1296/U	0-90° rotary step twist	RG-91/U	Includes UG-419/U and UG-541A/U, similar to, but not interchangeable with waveguide assembly CG-1136/U.
CG-1322/U	90° twist	RG-67/U	Includes UG-136B/U and UG-135/U; similar for interchangeable with waveguide assembly CG-985/U
CG-1329/U	Straight		Includes UG-1140/U and UG-418A/U
CG-1332/U	90° twist	RG-67/U (WR90)	Includes UG-136B/U and UG-135/U.
CG-1383/U	Straight		Includes UG-585A/U and UG-584/U exterior run from transition thru building to radar antenna.
CG-1412/U	Straight		Includes 2 UG-385/U.
CG-1416/U	90° E-bend		Includes UG-585A/U and UG-584/U 11.66-inch length overall.
CG-1421/U	85° E-bend		Includes UG-584/U and UG-585A/U 43.16-inch length overall.
CG-1422/U	U-bend in M-plane		Includes UG-584/U and UG-585A/U 21.31-inch length overall.
CG-1430/U	Straight		Includes UG-585A/U and UG-584/U 128.00-inch length overall.
CG-1513/U	Straight	RG-103/U	Includes 2 UG-418A/U.

^{1/} This type of corner consists of two sections of waveguide tubing soldered at oblique angles in order to affect the desired degree of bend.

^{2/} This type of corner consists of three sections of waveguide tubing soldered at oblique angles in order to affect the desired degree of bend.

NOTE:

For VSWR and bandwidth data for bend, corners, and twists refer to page 8.5 of this section.

MIL-HDBK-216
SECTION 8 A
7 April 1967

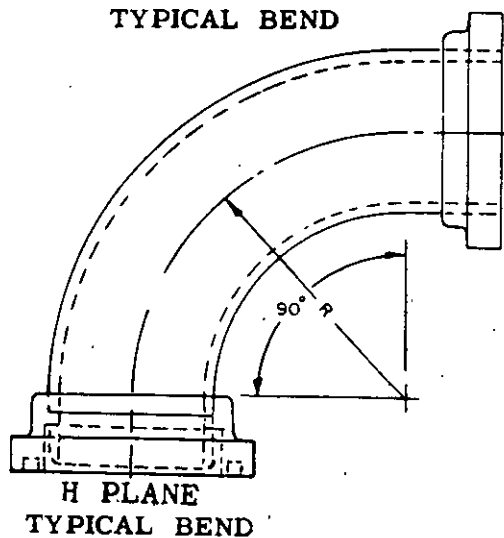
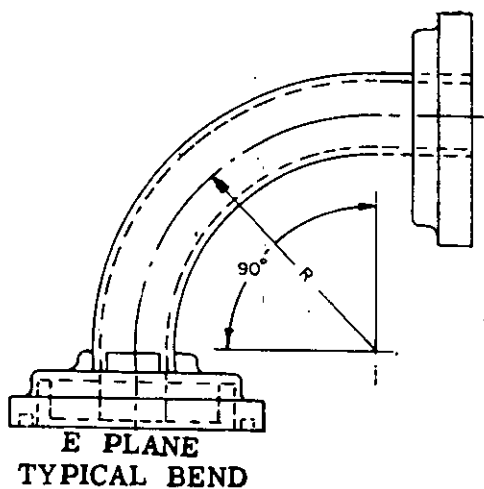
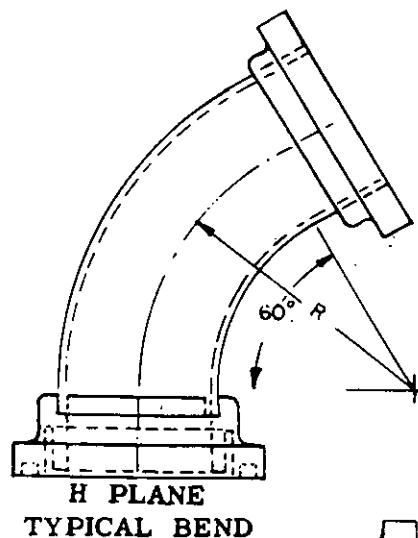
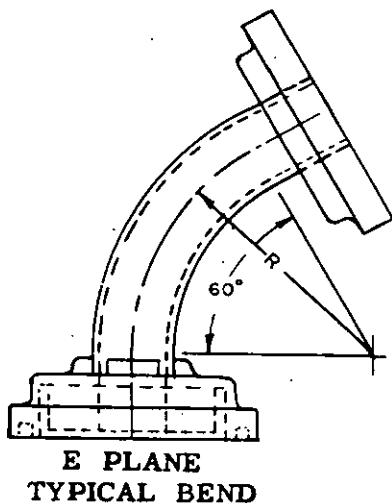
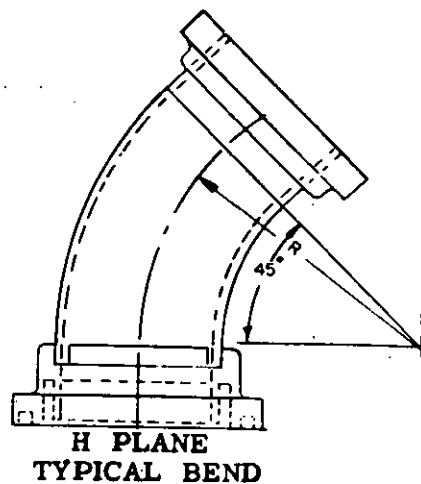
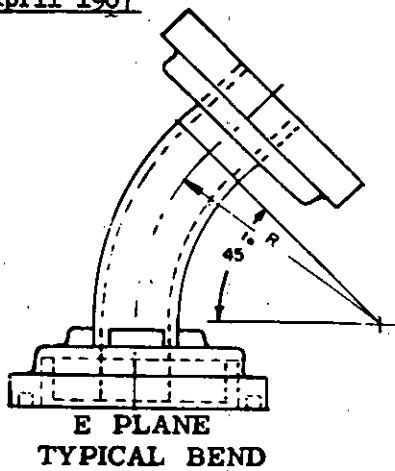
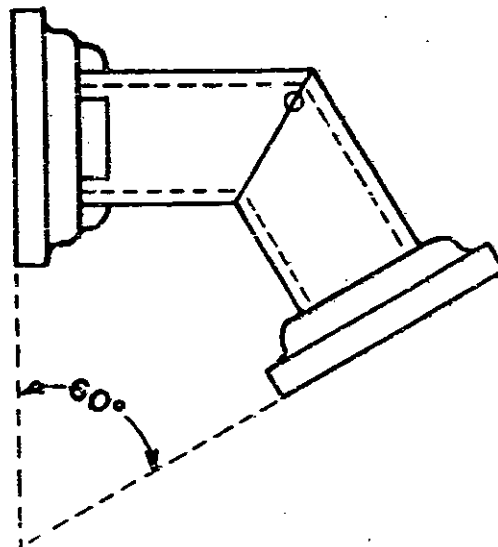
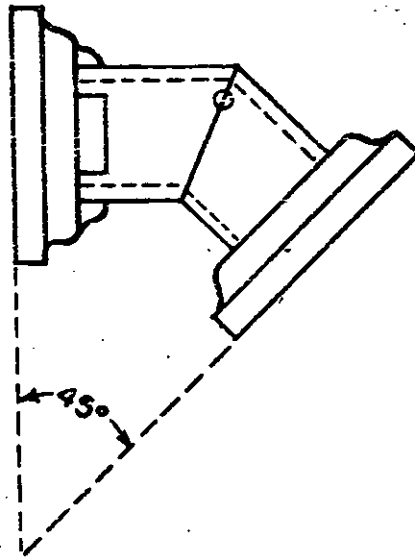

FIGURE 8.1. Typical bends.

MIL-HDBK-216
SECTION 8A
7 April 1967



TYPICAL CORNERS UTILIZING
TWO SECTIONS OF WAVEGUIDE

FIGURE 8.2. Typical corners.

MIL-HDBK-216
SECTION 8 A
7 April 1967

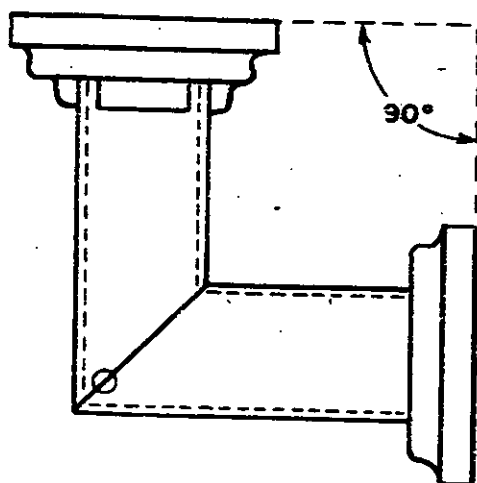

TYPICAL 90° CORNER
UTILIZING TWO SECTIONS
OF WAVEGUIDE

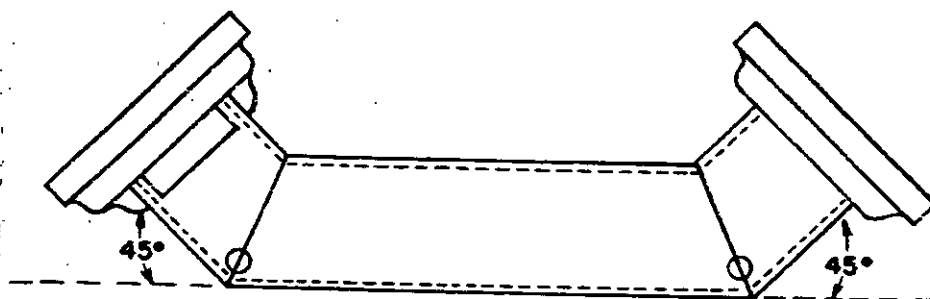

TYPICAL 90° CORNER
UTILIZING THREE SECTIONS
OF WAVEGUIDE

FIGURE 8.2. Typical comers (cont'd).

MIL-STD-216
SECTION 8A
7 April 1967

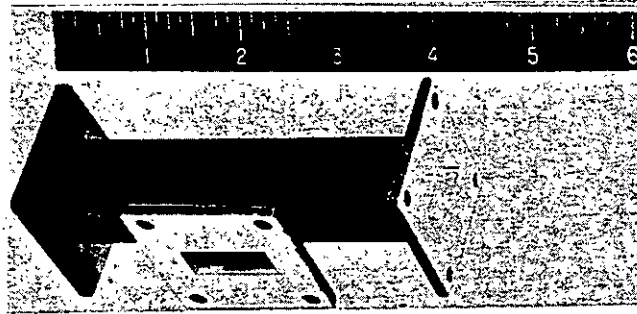

Typical shunt tee

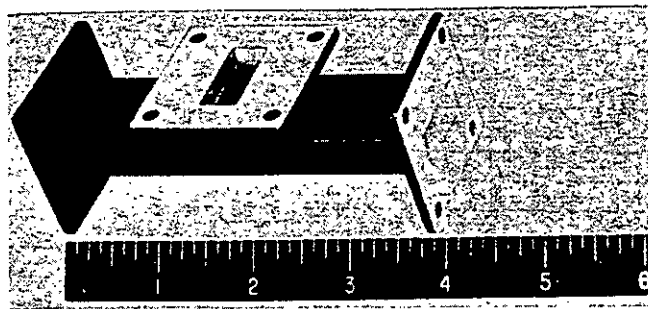

Typical series tee

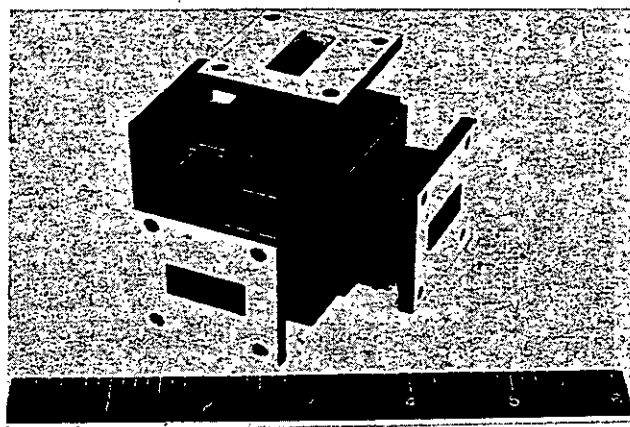

Typical magic tee

FIGURE 8.3. Typical shunt, series and magic tee.

MIL-HDBK-216
SECTION 9 A
7 April 1967
SUPERSEDING
Section 9
4 January 1962

SECTION 9 A

WAVEGUIDE ADAPTERS

9.1 General considerations

Waveguide adapters are used to provide a transition from a rigid rectangular waveguide to a coaxial line, using appropriate connectors at each end. Factors to be taken into consideration in using waveguide adapters are similar to those discussed in section 3.

Adapters preferred by the Armed Services are covered by MIL-A-22641 covering series N to waveguide, 5/8-inch coaxial line to waveguide and 7/8-inch coaxial line to waveguide. Contrary to previous practice, this specification does not establish piece part design criteria for the connector. It is a performance specification establishing only overall envelope and mating dimensions.

9.2 Tables.

Table I is a list of preferred waveguide adapters which indicates those adapters that have been selected by the Armed Services as the preferred types for use in electronic equipment. The purpose of the guide is to standardize waveguide adapters and to limit the number of types used in equipment of the Armed Services.

Table II is a list of waveguide adapters indicating functional description and pertinent engineering data.

MIL-EDHK-216
SECTION 9A
7 April 1967

TABLE 9.1. Preferred waveguide adapters.

UG type	Housing waveguide	Frequency range (MHz)	VSWR over entire freq. range	VSWR over 50% freq. range	Cover flange ^{1/}
UG-397/U	M85/1-069 RG-51/U	7,050 10,000	1.25	1.2	UG-51/U
UG-398/U	M85/1-063 RG-50/U	5,850 8,200	1.25	1.2	UG-344/U
UG-399/U	M85/1-051 RG-49/U	3,950 5,850	1.25	1.2	UG-149A/U
UG-400/U	M85/1-039 RG-48/U	2,600 3,950	1.25	1.2	UG-53/U
UG-403/U	M85/1-063 RG-50/U	5,850 8,200	1.3	1.2	UG-344/U
UG-404/U	M85/1-051 RG-49/U	3,950 5,850	1.3	1.2	UG-149A/U
UG-405/U	M85/1-039 RG-48/U	2,600 3,950	1.3	1.25	UG-53/U
UG-445/U	M85/1-039 RG-48/U	2,600 3,950	1.3	1.25	UG-53/U
UG-446A/U	M85/1-075 RG-52/U	8,200 12,400	1.25	1.2	UG-39/U
UG-520/U	M85/1-063 RG-50/U	5,850 8,200	1.3	1.2	UG-344/U
UG-521/U	M85/1-051 RG-49/U	3,950 5,850	1.3	1.2	UG-149A/U
UG-522/U	M85/1-039 RG-48/U	2,600 3,950	1.3	1.25	UG-53/U
UG-523/U	M85/1-039 RG-48/U	2,600 3,950	1.3	1.25	UG-53/U
UG-952/U	M85/1-027 RG-104/U	1,700 2,600	1.25	1.2	UG-435/U
UG-953/U	M85/1-015 RG-69/U	1,120 1,700	1.25	1.2	UG-417A/U
UG-1647/U	M85/1-065 RG-106/U	5,850 8,200	1.3	1.2	UG-441/U
UG-1648/U	M85/1-065 RG-106/U	5,850 8,200	1.3	1.2	UG-441/U
UG-1649/U	M85/1-041 RG-75/U	2,600 3,950	1.3	1.25	UG-584/U
UG-1650/U	M85/1-041 RG-75/U	2,600 3,950	1.3	1.25	UG-584/U
UG-1651/U	M85/1-053 RG-95/U	3,950 5,850	1.3	1.2	UG-407/U
UG-1652/U	M85/1-053 RG-95/U	3,950 5,850	1.3	1.2	UG-407/U
UG-1653/U	M85/1-071 RG-68/U	7,050 10,000	1.25	1.2	UG-138/U
UG-1654/U	M85/1-065 RG-106/U	5,850 8,200	1.25	1.2	UG-441/U
UG-1655/U	M85/1-053 RG-95/U	3,950 5,850	1.25	1.2	UG-407/U
UG-1656/U	M85/1-041 RG-75/U	2,600 3,950	1.25	1.2	UG-584/U
UG-1657/U	M85-1/077 RG-67/U	8,200 12,400	1.25	1.2	UG-135/U
UG-1658/U	M85/1-029 RG-105/U	1,700 2,600	1.25	1.2	UG-437A/U
UG-1659/U	M85/1-018 RG-103/U	1,120 1,700	1.25	1.2	UG-418A/U
UG-1660/U	M85/1-059 RG-344/U	4,900 7,050	1.25	1.2	RE49C735-14 UG-1355/U
UG-1661/U	M85/1-057 RG-343/U	4,900 7,050	1.25	1.2	RE49C735-13 UG-1354/U
UG-1662/U	M85/1-041 RG-75/U	2,600 3,950	1.3	1.25	UG-584/U
UG-1663/U	M85/1-041 RG-75/U	2,600 3,950	1.3	1.25	UG-584/U

^{1/}Cover flange in accordance with MIL-F-3922.

MIL-HDBK-216
SECTION 9 A
7 April 1967

TABLE 9.II. Waveguide adapters.

Type	Functional description	For use with waveguide types	Engineering data
UG-340/U	Waveguide to type N	RG-48/U (WR284)	Includes UG-66/U and type N female.
UG-397/U	Waveguide to type N	RG-51/U (WR112)	Includes UG-51/U and type N female.
UG-398/U	Waveguide to type N	RG-50/U (WR137)	Includes UG-344/U and type N female.
UG-399/U	Waveguide to type N	RG-49/U (WR187)	Includes UG-149A/U and type N female.
UG-400/U	Waveguide to type N	RG-48/U (WR284)	Includes UG-53/U and type N female.
UG-403/U	Waveguide to 5/8-inch rigid coaxial line	RG-50/U (WR137)	Includes UG-141/U and UG-344/U.
UG-404/U	Waveguide to 5/8-inch rigid coaxial line	RG-49/U (WR187)	Includes UG-141/U and UG-149A/U.
UG-405/U	Waveguide to 7/8-inch rigid coaxial line	RG-48/U (WR284)	Includes UG-46/U and UG-53/U.
UG-445/U	Waveguide to 5/8-inch rigid coaxial line	RG-48/U (WR284)	Includes UG-53/U and UG-140/U.
UG-446A/U	Waveguide to type N	RG-52/U (WR90)	Includes UG-39/U and type N female.
UG-500/U	Waveguide to type N	RG-48/U (WR284)	Includes UG-65/U and type N female.
UG-520/U	Waveguide to 5/8-inch coaxial line	RG-50/U (WR137)	Includes UG-140/U and UG-344/U.
UG-521/U	Waveguide to 5/8-inch coaxial line	RG-49/U (WR187)	Includes UG-140/U and UG-149A/U.
UG-522/U	Waveguide to 7/8-inch coaxial line	RG-48/U (WR284)	Includes UG-53/U and UG-45/U.
UG-523/U	Waveguide to 5/8-inch coaxial line	RG-48/U (WR284)	Includes UG-141/U and UG-53/U.
UG-551A/U	Waveguide to type N	RG-48/U	Includes UG-54A/U and type N female. Replaces UG-551/U.
UG-552/U	Waveguide to type N	RG-69/U (WR650)	Includes UG-417U and type N male.
UG-591/U	Waveguide to type N	RG-67/U (WR90)	Includes UG-135/U and type N female.
UG-592/U	Waveguide to type N	RG-67/U (WR90)	Includes UG-136/U and type N female.
UG-647/U	Waveguide to type N	RG-50/U (WR137)	
UG-687/U	Waveguide to type N	RG-52/U (WR90)	Includes UG-40A/U and type N male.
UG-688/U	Waveguide to type N	RG-52/U (WR90)	Includes UG-39/U and type N female.
UG-841/ FPS-6	Waveguide to type N	RG-75/U (WR284)	Includes UG-585/U and type N female.
UG-952/U	Waveguide to type N	RG-104/U (WR430)	Includes UG-435A/U and UG-20B/U.
UG-953/U	Waveguide to type N	RG-69/U (WR650)	Includes UG-417A/U and UG-20B/U.
UG-1001/U	Waveguide to type N	RG-109/U	Includes UG-509/U and type N female.
UG-1002/U	Waveguide to type N	RG-110/U	Includes UG-511/U and type N female.
UG-1004/U	Waveguide to type N	RG-109/U	Includes UG-509/U and type N female.

MIL-HDBK-216
SECTION 9
7 April 1967

TABLE 9.II. Waveguide adapters. (Continued)

Type	Functional description	For use with waveguide types	Engineering data
UG-1005/U	Waveguide to type N	RG-110/U	Includes UG-511/U and type N female.
UG-1023/U	Waveguide to type N	RG-52/U (WR90)	Includes UG-40A/U and type N female.
UG-1026/U	Waveguide to 1-5/8 inch	RG-46, 69/U (WR650)	Includes stainless steel UG-417A/U and UG-50/U.
UG-1031/U	Waveguide to 7/8-inch rigid coaxial line	RG-44, 69/U (WR650)	Includes stainless steel UG-417A/U One end and UG-45/U on other.
UG-1053/U	Waveguide to type N	RG-52/U (WR90)	Includes UG-39/U and type N.
UG-1054/U	Waveguide to type N	RG-51/U (WR112)	Includes UG-51/U and type N.
UG-1151/U	Waveguide to type C	RG-48/U (WR284)	Includes UG-53/U and type C.
UG-1152/U	Waveguide to type C	RG-49/U (WR187)	Includes UG-149A/U and type C.
UG-1153/U	Waveguide to type C	RG-52/U (WR90)	Includes UG-39/U and type C.
UG-1212/U	Ridged waveguide to ridged waveguide		Connects 3.047 x 1.371 I.D. ridged waveguide to 3.65 x 3.65 I.D. to ridged waveguide.
UG-1217/U	Ridged waveguide to coaxial line		Adapts a 50 ohm coaxial cable to a ridged waveguide system.
UG-1218/U	Waveguide to ridged waveguide	RG-69/U	Connects RG-69/U to 3.047 x 1.371 I.D. ridged waveguide.
UG-1219/U	Waveguide to ridged waveguide	RG-104/U	Connects RG-104/U to 3.047 x 1.371 I.D. ridged waveguide.
UG-1280/U	Waveguide to coaxial		Connects a 9.750 x 4.875 I.D. waveguide to 3.125 OD 50 ohms.
UG-1289/U	Waveguide to type N		Connects a 1.372 x 0.622 I.D. waveguide to type N connector.
UG-1290/U	Waveguide to type N		Connects a 1.872 x 0.872 I.D. waveguide to type N connector.
UG-1647/U	Waveguide to 5/8-inch rigid coaxial line	RG-106/U	Includes UG-141/U and UG-441/U.
UG-1648/U	Waveguide to 5/8-inch rigid coaxial line	RG-106/U	Includes UG-140/U and UG-441/U.
UG-1649/U	Waveguide to 5/8-inch rigid coaxial line	RG-75/U	Includes UG-140/U and UG-584/U.
UG-1650/U	Waveguide to 5/8-inch rigid coaxial line	RG-75/U	Includes UG-141/U and UG-584/U.
UG-1651/U	Waveguide to 5/8-inch rigid coaxial line	RG-95/U	Includes UG-140/U and UG-407/U.
UG-1652/U	Waveguide to 5/8-inch rigid coaxial line	RG-95/U	Includes UG-141/U and UG-407/U.
UG-1653	Waveguide to type N	RG-68/U	Includes UG-138/U and type N female.
UG-1654	Waveguide to type N	RG-106/U	Includes UG-441/U and type N female.
UG-1655	Waveguide to type N	RG-95/U	Includes UG-407/U and type N female.

MIL-HDBK-216
SECTION 9A
7 April 1967

TABLE 9.II. Waveguide adapters. (Continued)

Type	Functional description	For use with waveguide types	Engineering data
UG-1656	Waveguide to type N	RG-75/U	Includes UG-584/U and type N female.
UG-1657	Waveguide to type N	RG-67/U	Includes UG-135/U and type N female.
UG-1658	Waveguide to type N	RG-105/U	Includes UG-437A/U and type N female.
UG-1659	Waveguide to type N	RG-103/U	Includes UG-418A/U and type N female.
UG-1660	Waveguide to type N	RG-344/U	Includes UG-1355/U and type N female.
UG-1661	Waveguide to type N	RG-343/U	Includes UG-1354/U and type N female.
UG-1662	Waveguide to 7/8-inch rigid coaxial line	RG-75/U	Includes UG-45/U and UG-584/U.
UG-1663	Waveguide to 7/8-inch rigid coaxial line	RG-75/U	Includes UG-46/U and UG-584/U.

MIL-HDBK-216
SECTION 9 A
7 April 1967

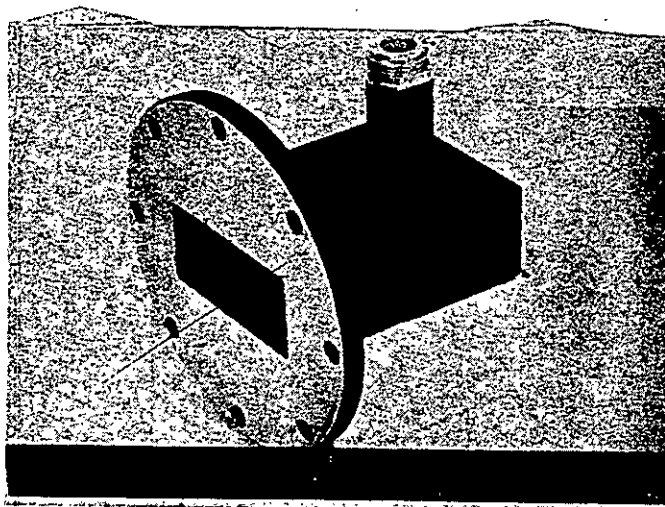

FIGURE 9.1. Typical waveguide to type N adapter.

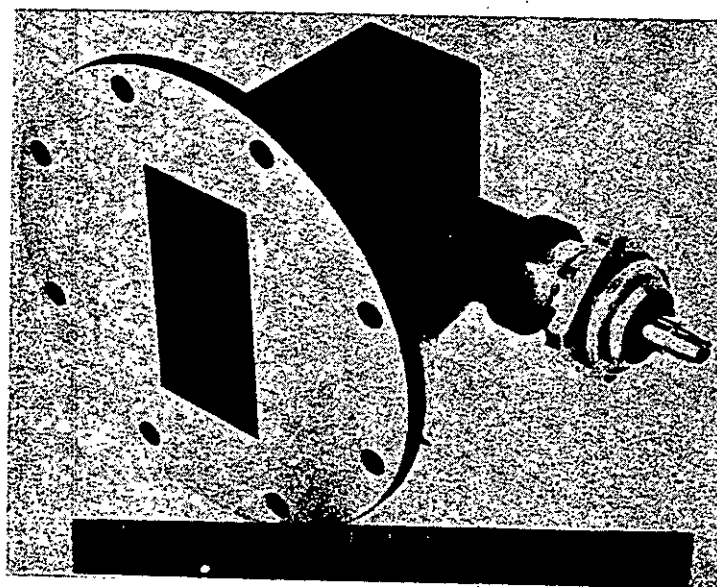

FIGURE 9.2. Typical waveguide to coaxial line adapter.

SECTION 10

WAVEGUIDE SWITCHES

10-1 General considerations.

General considerations for waveguide switches are similar to those for RF switches discussed in section 4.

10-2 Tables.

The waveguide switches listed in this part are used in conjunction with preferred waveguide flanges. They may be operated manually, or can be operated electrically by remote control. They are available in a varied number of switching positions and are designed for specific applications.

MIL-HDBK-216
4 January 1962

WAVEGUIDE SWITCHES

Type	Frequency (Kmc/sec)	VSWR	No. of parts	Flange Type	Method of actuation	Engineering data
SA-221/MPN-5			2		2 Motors	28 _v DC
SA-222/UP			2		Motor	28 _v DC
SA-269/U	27.0-29.0		3	UG-599/U UG-600/U	Solenoid	120 _v AC
SA-270/U	27.0-29.0		3	UG-599/U UG-600/U	Solenoid	120 _v AC
SA-361/U	27.0-29.0		3	UG-599/U UG-54A/U	Motor	
SA-340/U		1.05	3			
SA-364/U	9.18 (max)				Solenoid	48 _v DC
SA-374/U			2		Solenoid	
SA-380/U	7.05-10.0		3	UG-53/U	Manual	
SA-381/U	7.05-10.0		3	UG-53/U	Manual	
SA-436/FPS-14	7.05-10.0		3	UG-53/U	Motor	115 _v AC
SA-437/BPS-3	5.12-366		3	UG-344A/U	Motor	115 _v AC
SA-448/FPS-20	1.12-1.70		4	UG-418A/U	Motor	120 _v AC
SA-489/U	2.8-2.95	1.10	3	UG-584/U UG-585/U	Solenoid	28 _v DC
SA-490/U	2.8-2.95	1.10	3	UG-584/U UG-585/U	Solenoid	110 _v DC
SA-509/U	3.10-3.50	1.10	3	UG-584/U UG-585/U	Solenoid	28 _v DC
SA-510/U	3.10-3.50	1.10	3	UG-584/U UG-585/U	Solenoid	110 _v DC
SA-511/U	8.5-9.6	1.10	3	UG-135/U UG-136/U	Solenoid	28 _v DC
SA-512/U	8.5-9.6	1.10	3	UG-52/U UG-51/U	Solenoid	28 _v DC
SA-516/U	5.0-6.0	1.10	3	UG-406/U UG-407/U	Solenoid	28 _v DC
SA-518/ APS-62	7.05-10.0		3	UG-53A/U UG-54A/U	Solenoid	28 _v DC
SA-527/AEK			3		Solenoid	28 _v DC
SA-540/UP	1.12-1.70		3	UG-417A/U UG-418A/U	Motor or Manual	115 _v AC
SA-541/UP	2.2-3.3		3	UG-553/U UG-554/U	Motor or Manual	115 _v AC

MIL-HDBK-216
4 January 1962

WAVEGUIDE SWITCHES — Continued

Type	Frequency (Kms/sec)	VSWR	No. of parts	Flange Type	Method of actuation	Engineering data
SA-560/FPS-33	1.12-1.70		3	UG-417A/U UG-418A/U	Motor	120 _v AC
SA-563/U	8.2-12.4		9	UG-40B/U UG-39/U		
SA-583/U	13.0-17.0	1.10 (max)	3	UG-541/U UG-419/U	Solenoid	115 _v AC
SA-605/U			3	UG-137B/U	Solenoid	28 _v DC
SA-610/TPN-12			3		Solenoid	
SA-641/U	2.3-5.0		3	UG-53/U UG-54A/U	Solenoid	115 _v AC
SA-642/U	5.0-10.75		3	UG-343/U UG-344/U	Solenoid	115 _v AC
SA-643/U			3		Solenoid	110 _v AC
SA-667/U			3	UG-137A/U	Manual	
SA-698/FPS-26			3		Motor	120 _v AC
SA-699/FPS-26			3		Motor	120 _v AC
SA-709/FPS-26			3		Motor	120 _v AC

MIL-HDEK 216
4 January 1962

TYPICAL WAVEGUIDE SWITCH

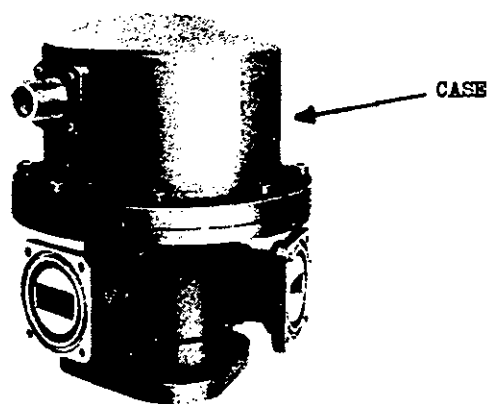

NOTE: OUTSIDE CASE MAY BE RECTANGULAR OR CIRCULAR

SECTION 11

FITTINGS FOR RIGID COAXIAL LINES

11-1 General considerations.

General considerations for fittings for rigid coaxial lines are similar to those discussed for waveguide couplings, Section 7.

11-2 Table.

The fittings listed in this part are weatherproof and can be used at the same frequencies and power for which the associated coaxial line is designed.

NAV-EDDK-216
4 January 1962

FITTINGS FOR RIGID COAXIAL LINES

TYPE	DESCRIPTION	FOR USE WITH	FOR LINE SIZE	ENGINEERING DATA
UG-43/U	Male coupling	RG-49/U	1/2	Mates with UG-44/U
UG-44/U	Female coupling	RG-47/U	1/2	Mates with UG-43/U
UG-45/U	Male coupling	RG-44/U	7/8	Mates with UG-46/U
UG-46/U	Female coupling	RG-44/U	7/8	Mates with UG-45/U
UG-47/U	Male coupling	RG-45/U	1-1/4	Mates with UG-48/U
UG-48/U	Female coupling	RG-45/U	1-1/4	Mates with UG-47/U
UG-49/U	Male coupling	RG-46/U	1-5/8	Mates with UG-50/U
UG-50/U	Female coupling	RG-46/U	1-5/8	Mates with UG-49/U
UG-140/U	Male coupling	RG-76/U	5/8	Mates with UG-141/U
UG-141/U	Female coupling	RG-76/U	5/8	Mates with UG-140/U
UG-267/U	Male coupling	RG-80/U	15/16	Mates with UG-268/U
UG-268/U	Female coupling	RG-80/U	15/16	Mates with UG-267/U
UG-339/U	Adapter			1-5/8 inch to 3-1/8 coaxial transition
UG-465/U	Tee	RG-76/U	5/8	Includes 3 UG-140/U
UG-466/U	Tee	RG-44/U	7/8	Includes 3 UG-45/U
UG-508/U	Adapter			7/8 inch to 3/8 inch coaxial transition
UG-677/U	Coupling	RG-128/U	1-5/8	1 male, 1 female
UG-1115/U	Female coupling	RG-155/U	7/8	Mates with UG-1116/U
UG-1116/U	Male coupling	RG-155/U	7/8	Mates with UG-1115/U
UG-1117/U	Bend, 45°	RG-155/U	7/8	0-2 kmc frequency range; 50 ohm impedance
UG-1118/U	Adapter		1-5/8 to 7/8	0-2 kmc frequency range; 50 ohm impedance
UG-1156/U	Elbow, Right angle	RG-153/U	1-5/8	Includes flanges UG-1157 and UG-1163/U
UG-1157/U	Outer contact flange	RG-153/U	1-5/8	Mates with UG-1163/U
UG-1158/U	Outer contact flange	RG-155/U	7/8	Mates with UG-1159/U
UG-1159/U	Outer contact flange	RG-155/U	7/8	Mates with UG-1158/U
UG-1160/U	Adapter	RG-153/U & -155/U	1-5/8 to 7/8	Includes flange UG-1158/U on one end; other end mates with UG-1163/U
UG-1161/U	Bullet	RG-153/U	1-5/8	0-2 kmc frequency range; 50 ohm impedance
UG-1162/U	Elbow, Right angle	RG-155/U	7/8	Includes flanges UG-1158/U and UG-1159/U
UG-1163/U	Outer contact flange	RG-153/U	1-5/8	Mates with UG-1157/U
UG-1164/U	Bullet	RG-155/U	7/8	0-4 kmc frequency range; 50 ohm impedance
CG-1373/U (ft-in)	Line section assembly	RG-153/U	7/8	Includes flanges UG-1157/U & UG-1163/U
CG-1374/U (ft-in)	Line section assembly	RG-155/U	1-5/8	Includes flanges UG-1158/U & UG-1159/U
MX-1066/U	Coupling		1-5/8	
MX-1067/U	Coupling		1-5/8	

EIA Standard RS-225
Rigid Coaxial Transmission Line
Flanges (50 Ohms)

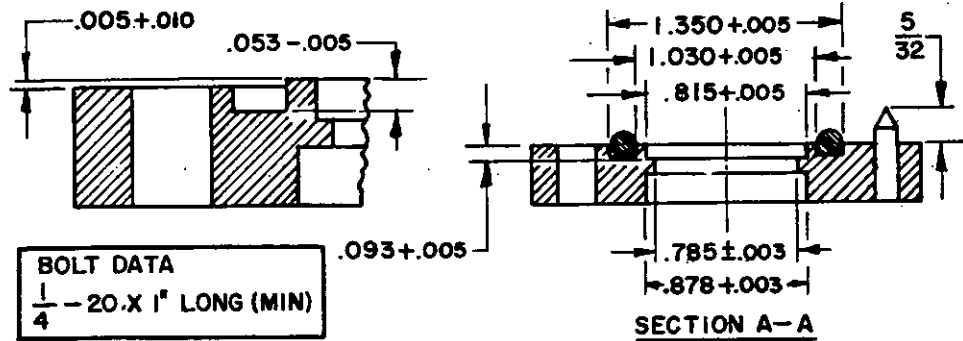
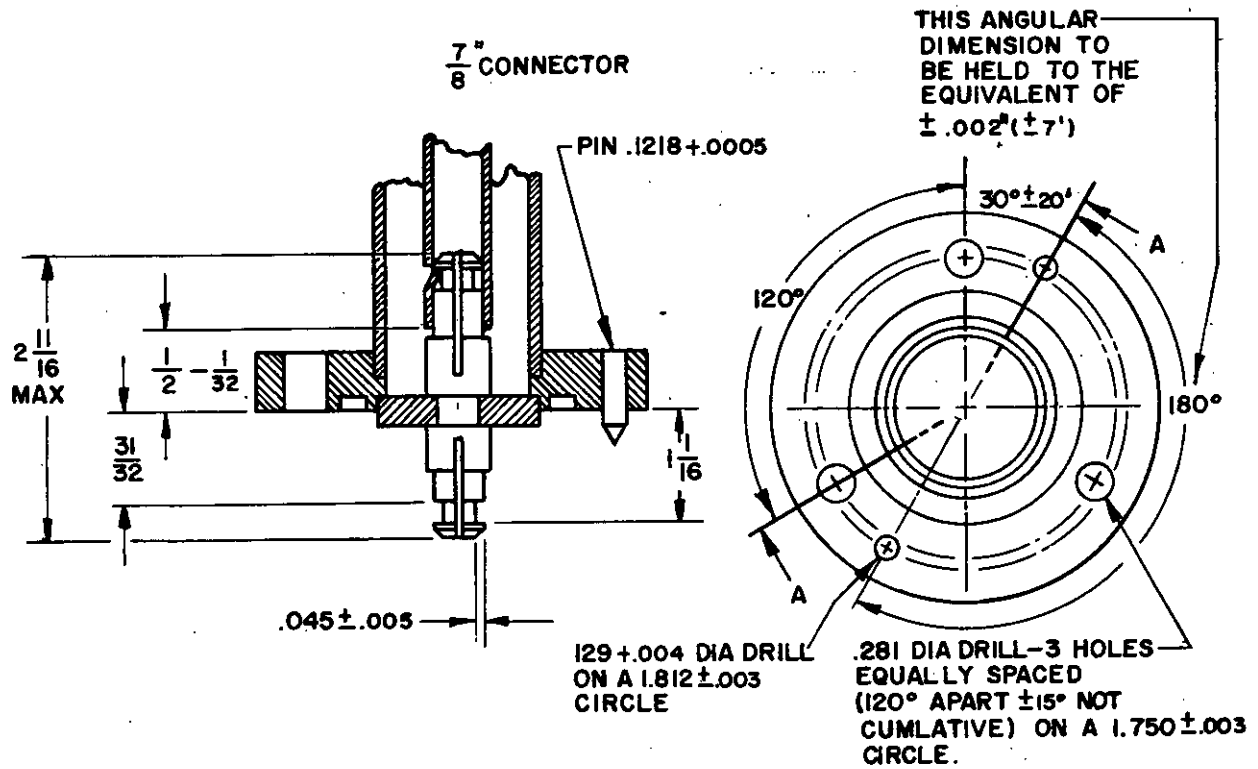

- NOTES: 1. FRACTIONAL DIMENSIONS $\pm \frac{1}{64}$ UNLESS OTHERWISE SPECIFIED
2. ALL DIAMETERS TO BE CONCENTRIC WITHIN .005 EXCEPT STOCK SIZE (O.D.)

FIG. 1

MIL-HDBK-216
4 January 1962

EIA Standard RS-225
Rigid Coaxial Transmission Line
Flanges (50 Ohms)

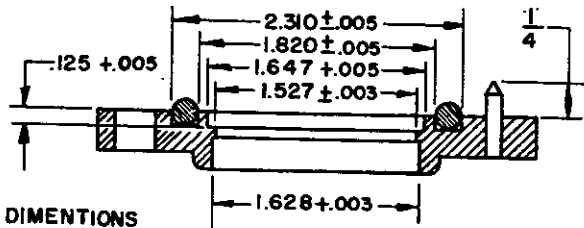
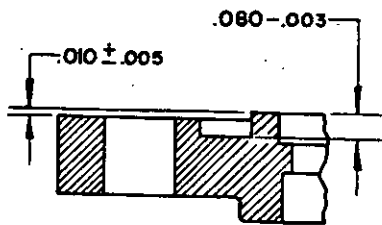
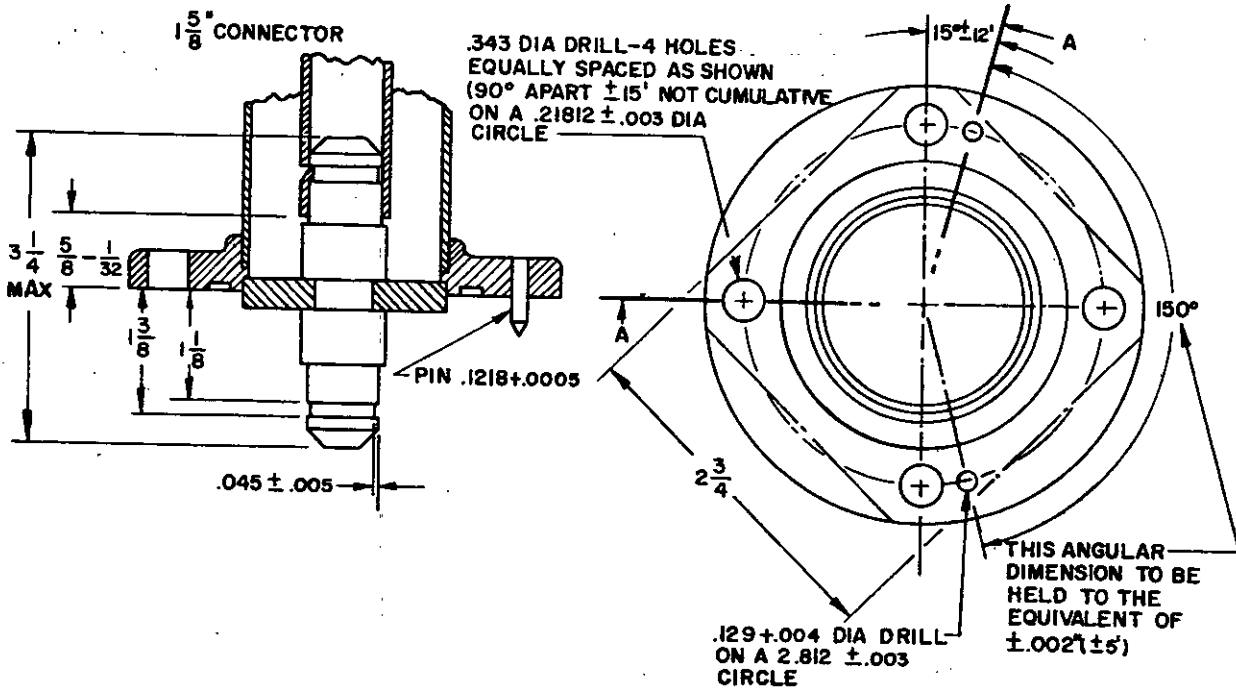

BOLT DATA
5/16 - 18 X 1 3/8 LONG (MIN)

- NOTES: 1. FRACTIONAL DIMENSIONS
± 1/64 UNLESS OTHERWISE SPECIFIED SECTION A-A
2. EITHER SQUARE OR ROUND FLANGE IS ACCEPTABLE
3. ALL DIAMETERS TO BE CONCENTRIC WITHIN .005 EXCEPT STOCK SIZE (O.D.)
- FIG. 2

EIA Standard RS-225
Rigid Coaxial Transmission Line
Flanges (50 Ohms)

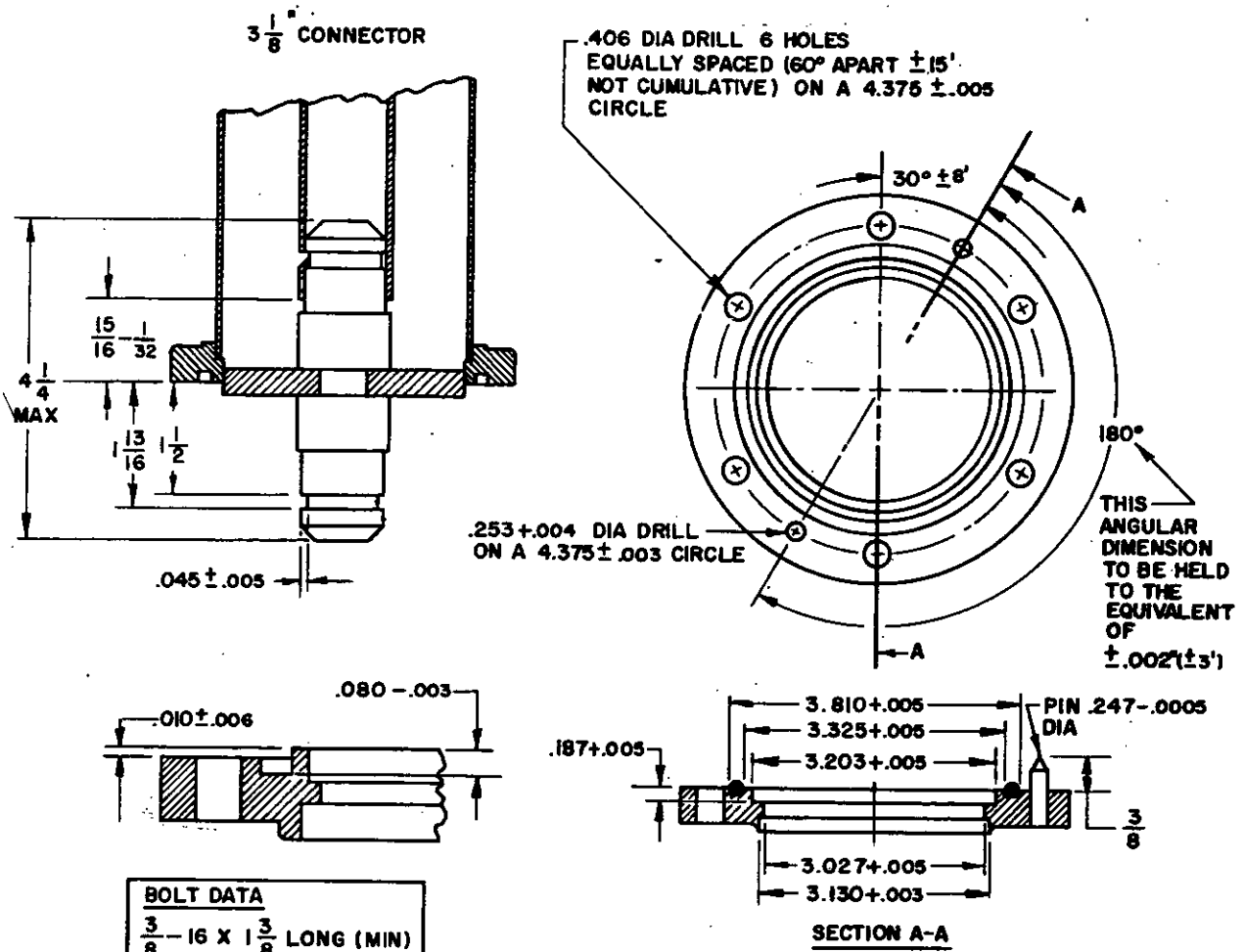

NOTES: 1. FRACTIONAL DIMENSIONS $\pm \frac{1}{64}$ UNLESS OTHERWISE SPECIFIED.
2. ALL DIAMETERS TO BE CONCENTRIC WITHIN .005 EXCEPT STOCK SIZE O.D.

FIG 3

MLL-EDHK-216
4 January 1982

MIL Standard BS-225
Rigid Coaxial Transmission Line
Flanges (50 Ohms)

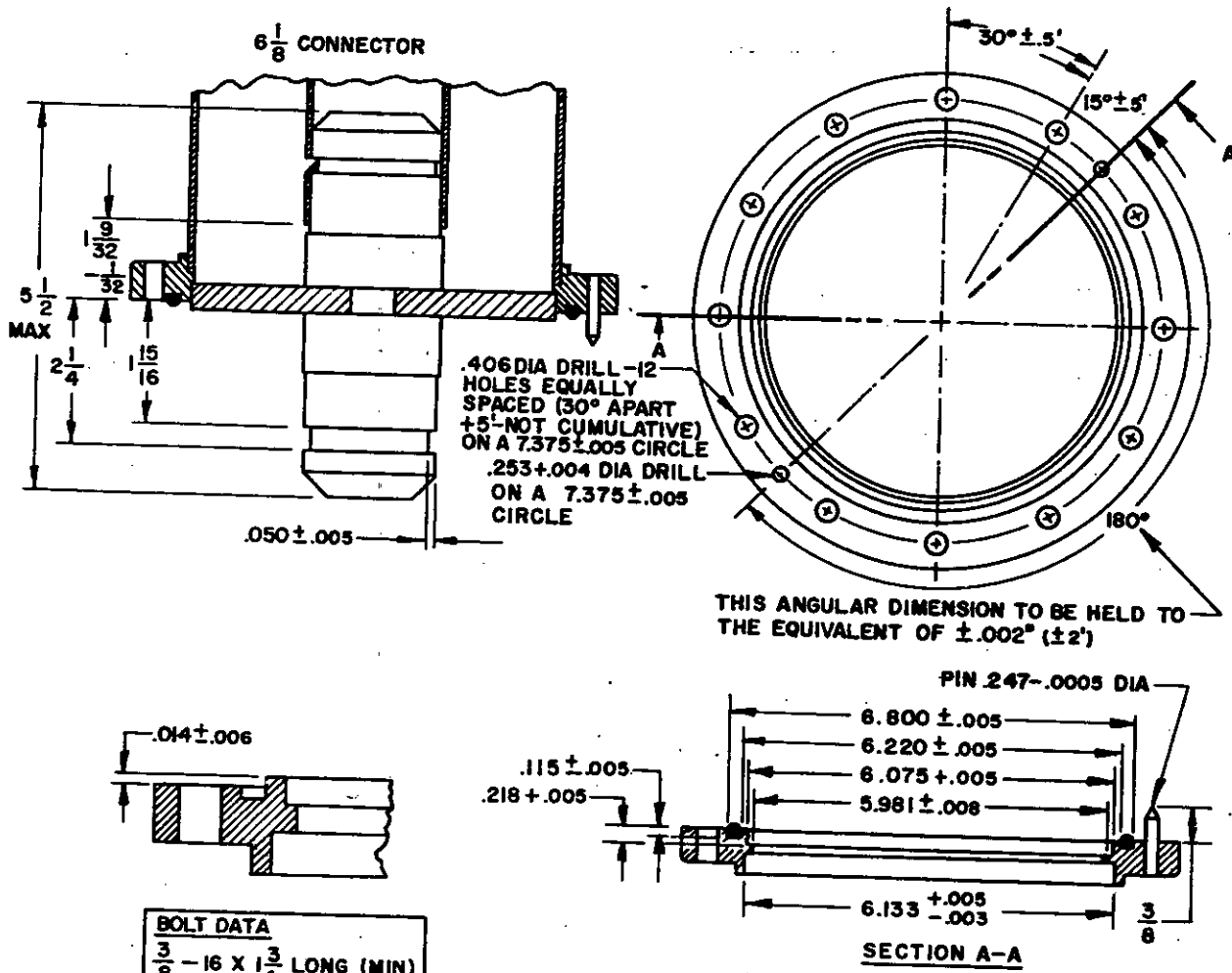

- NOTES: 1. FRACTIONAL DIMENSION ± 1/64 UNLESS OTHERWISE SPECIFIED
2. ALL DIAMETERS TO BE CONCENTRIC WITHIN .005 EXCEPT STOCK SIZE (O.D.)

FIG. 4

SECTION 12
DIRECTIONAL COUPLERS12-1 General considerations.

Directional couplers are designed to provide nominal responses in secondary lines to propagation on the main line. The uni-directional coupler provides a nominal response in the secondary line to propagation in the main line, in one direction only. A bi-directional coupler provides separate and simultaneous nominal responses in the secondary lines to each of the two directions of propagation in the main line while a multi-directional coupler provides more than two such nominal responses.

12-2 Table.

This part lists the directional couplers currently used by the Armed Services.

MIL-HDBK-216
4 January 1962

DIRECTIONAL COUPLERS

Type	Description	For use with	Primary line termination	Secondary line output	Coupling ^{1/} (db)	Engineering data
CU-57/AP	Unidirectional		UG-46/U	UG-45/U		
CU-60/AP	Unidirectional		UG-46/U	UG-45/U		
CU-72/APS-15B	Unidirectional	RG-52/U			20	
CU-73/APS-15A	Unidirectional	RG-52/U			20	
CU-78/UP	Bidirectional	RG-51/U		Type N female	26.5	8.5 - 9.6 KMC
CU-79/UP	Bidirectional	RG-51/U		Type N female	26	9.32 - 9.43 KMC
CU-83/U	Unidirectional	RG-48/U		Type N female	27	
CU-89/UP	Unidirectional			Type N female	20	X-band used in MK-12
CU-90/UP	Unidirectional			Type N female	20	2.9 - 3.1 KMC
CU-95/UP	Unidirectional	RG-48/U		Type N female	34	3.4 - 3.7 KMC
CU-103/APS-32	Unidirectional	RG-53/U		UG-116/U	20	
CU-104/APS-34	Unidirectional	RG-53/U		UG-116/U	20	
CU-105/APS-31	Unidirectional	UG-39/U	UG-39/U and UG-40/U	Type N female	25	
CU-106A/APS-33	Unidirectional	UG-40/U	Mates UG-40/U	Type N female	25	
CU-115/U	Unidirectional	RG-46/U		Type N female	25	
CU-118/UP	Unidirectional			Type N female	20	8.995 - 9.175 KMC
CU-122/U		RG-52/U	UG-39/U UG-40/U	Type N	20	8.20 - 12.40 KMC
CU-123/U	Unidirectional	RG-44/U	UG-45/U and UG-46/U	Type N	26.5	
CU-127/UP	Unidirectional	RG-53/U	UG-116/U and UG-117/U	UG-117/U	20	23.5 - 24.5 KMC
CU-129/APS-19	Unidirectional			Type N female	25	
CU-135/UP	Bidirectional	RG-52/U	UG-39/U and UG-40/U		20	
CU-136/UP	Bidirectional	RG-66/U	UG-116/U and UG-117/U	UG-116/U and UG-117/U	20	
CU-137/APS-23	Unidirectional	RG-52/U	UG-39/U and UG-40/U	Type N female	30	

¹ See footnote at end of table.

MIL-HDBK-216
4 January 1962

DIRECTIONAL COUPLERS — Continued

Type	Description	For use with	Primary line termination	Secondary line output	Coupling ¹ (db)	Engineering data
CU-146/UP	Bidirectional	RG-52/U	UG-39/U and UG-40/U	Type N female	20	VSWR 1.1 9.09 KMC
CU-147/U	Unidirectional	7/8-in. coaxial	UG-46/U and UG-45/U	Type N female	35	
CU-159/U		RG-52/U	UG-39/U and UG-40/U	Cover flange Choke flange		8.20 - 12.40
CU-160/UP	Bidirectional	RG-51/U		Type N female	25.3	
CU-162/U	Bidirectional	RG-51/U	UG-51/U	UG-39/U	23 inci- dent; 33 reflection	
CU-164/AP		RG-51/U	UG-51/U and UG-52A/U	Cover flange Choke flange	30	7.05 - 10.00 KMC
CU-165/U	Bidirectional	RG-51/U		Type N female	30	
CU-175/U			UG-60A/U Each End	Series EN	0.5	
CU-176/AP	Unidirectional	RG-52/U	UG-39/U and UG-40/U	Type N female	20	
CU-177/MPN-1B		RG-48/U	UG-53/U and UG-54A/U	Cover flange Choke flange	25	2.60 - 3.95 KMC
CU-187/U	Unidirectional	RG-92/U	UG-45/U and UG-46/U	Type N female	20	0.12 - 0.24 KMC 50 watts av- erage power
CU-188/U	Unidirectional	RG-92/U	UG-45/U and UG-46/U	Type N female	20	0.24 - 0.48 KMC
CU-189/U	Unidirectional	RG-92/U	UG-45/U and UG-46/U	Type N female	20	0.48 - 0.96 KMC
CU-190/U	Unidirectional	RG-92/U	UG-45/U and UG-46/U	Type N female	20	0.96 - 1.99 KMC
CU-191/U	Unidirectional	RG-92/U	UG-45/U and UG-46/U	Type N female	20	2.70 - 3.35 KMC
CU-198/U	Unidirectional	RG-48/U	UG-53/U	Type N female	20	2.70 - 3.35 KMC
CU-199/U	Unidirectional	RG-48/U	UG-53/U	Type N female	20	3.35 - 4.00 KMC
CU-200/U	Unidirectional	RG-49/U	UG-149A/U	Type N female	20	4.0 - 5.0 KMC

¹ See footnote at end of table.

MIL-HDBK-216
4 January 1962

DIRECTIONAL COUPLERS — Continued

Type	Description	For use with	Primary line termination	Secondary line output	Coupling ^{1/} (db)	Engineering data
CU-201/U	Unidirectional	RG-49/U	UG-149A/U	Type N female	20	5.0 - 6.0 KMC
CU-202/U	Unidirectional	RG-50/U	UG-344/U	Type N female	20	5.3 - 7.0 KMC
CU-203/U	Unidirectional	RG-50/U	UG-344/U	Type N female	20	7.0 - 8.2 KMC
CU-204/U	Unidirectional	RG-51/U	UG-51/U	Type N female	20	7.0 - 8.5 KMC
CU-205/U	Unidirectional	RG-51/U	UG-51/U	Type N female	20	8.5 - 10.0 KMC
CU-206/U	Unidirectional	RG-52/U	UG-39/U	Type N female	20	8.2 - 10.3 KMC
CU-207/U	Unidirectional	RG-52/U	UG-39/U	UG-39/U	20	10.3 - 12.4 KMC
CU-208/U	Unidirectional	RG-91/U	UG-419/U	UG-419/U	20	12.4 - 15.2 KMC
CU-209/U	Unidirectional	RG-91/U	UG-419/U	UG-419/U	20	15.2 - 18.0 KMC
CU-210/U	Unidirectional	RG-53/U	UG-425/U	UG-425/U	20	18.0 - 22.2 KMC
CU-211/U	Unidirectional	RG-53/U	UG-425/U	UG-425/U	20	22.2 - 26.5 KMC
CU-212/U	Unidirectional	RG-96/U	UG-381/U	UG-381/U	20	26.5 - 31.5 KMC
CU-213/U	Unidirectional	RG-96/U	UG-381/U	UG-381/U	20	31.5 - 36.0 KMC
CU-214/UP	Unidirectional	RG-92/U	UG-45/U and UG-46/U	Type N female	35	
CU-217/U	Unidirectional	RG-67/U	UG-136/U and UG-135/U	Type N female	20	Similar to CG-176/AP
CU-222/U	Bidirectional			Type UHF	20	300 ohm open wire
CU-224/U	Unidirectional	1-5/8-inch line	UG-49/U and UG-50/U	Type N female	33	1.15 - 1.35 KMC
CU-225/U	Unidirectional	RG-69/U	UG-417/U	Type N female	35	1.13 - 1.35 KMC
CU-233/FFS-3		RG-69/U	UG-417A/U	Contact flange UG-417A/U	35	1.12 - 1.70 KMC
CU-236/CFN-18		RG-48/U	UG-200/A/U UG-214/U	Choke flange	27	2.60 - 3.95 KMC
CU-243/UP		RG-48/U	UG-200/U	Choke flange	35	2.60 - 3.95 KMC
CU-245/U		RG-50/U	UG-150/U	Contact flange UG-150/U	20	5.85 - 8.20 KMC

¹ See footnote at end of table.

MIL-HDBK-216
4 January 1962

DIRECTIONAL COUPLERS — Continued

Type	Description	For use with	Primary line termination	Secondary line output	Coupling ^{1/} (db)	Engineering data
CU-258/U	Unidirectional	RG-52/U	UG-39/U and UG-40/U	Type N female	30	
CU-263/U		RG-52/U	UG-39/U	Cover flange	25	3.20 - 12.40 ENC
CU-267/U		RG-52/U	UG-39/U and UG-40A/U	Cover flange Choke flange	22	8.20 - 12.40 ENC
CU-295/U	Unidirectional	RG-48/U	UG-54/U and UG-53/U		37.2	2860 - 2900 MC
CU-312/SPS-12				Type N	38	
CU-316/APS-20B	Unidirectional			Type N female	40.0	2850 - 1910 MC
CU-319/FPS-8	Unidirectional			Type N female	44.5	1200 - 1400 MC
CU-323/APW-81				Type N	20	
CU-325/U	Bidirectional	RG-69/U	UG-417A/U	Type N female	35.0	1250 - 1350 MC
CU-333/UEN-60	Bidirectional	RG-17, 18/U	UG-154/U and UG-352A/U	Type N male	47.0	2000 - 4200 MC VSWR 1.5
CU-338/AP	Unidirectional	RG-51/U	UG-52A/U UG-51/U		27.0	9335 - 9415 MC
CU-339/AP	Unidirectional	RG-52/U	UG-40A/U and UG-39/U		22.7	9205 - 9285 MC
CU-341/U	Unidirectional	RG-52/U		Type N	20	9310 - 9415 MC
CU-349/APS-25		RG-51/U	UG-51/U UG-52/U	Type N	20	7.05 - 10.00
CU-354/MPQ-12		RG-44/U	UG-45/U and UG-46/U	Type N	25	
CU-356/SPW-18		RG-51/U	UG-51/U and UG-52A/U	Type N	21	7.05 - 10.00 ENC
CU-358/U					43	
CU-387/FPW-28		RG-75/U	UG-584/U UG-585	Type N female	35	2.60 - 3195 ENC
CU-388/FPW-28		RG-67/U	UG-135/U and UG-136A/U		20	8.20 - 12.40 ENC
CU-401/APS-64		RG-52/U	UG-39/U and UG-40A/U			8.20 - 12.40 ENC

¹ See footnote at end of table.

MIL-HDBK-216
4 January 1962

DIRECTIONAL COUPLERS — Continued

Type	Description	For use with	Primary line termination	Secondary line output	Coupling ^{1/} (db)	Engineering data
CU-428/FPN-13		CG-154/U	UG-40/U Each end		10	8.20 - 12.40 KMC
CU-430/URN-3		RG-44/U	UG-45/U and UG-46/U		40	
CU-431/URN-3		RG-55/U	UG-264/U	Type HNC	25	
CU-446/GPS-4		RG-69/U	UG-418A/U	Type N Male	40	1.12 - 1.70 KMC
CU-447/APW-16		RG-67/U	UG-135/U and UG-136A/U		15.5	8.20 - 12.40 KMC
CU-453/FPS-14		RG-48/U	UG-53/U and UG-54A/U			2.60 - 3.95 KMC
CU-455/URN-87		RG-117/U and RG-118/U	UG-532A/U	Type LT	40	
CU-456/U		RG-17/U and RG-18/U	UG-352/U	Type LC	30	
CU-457/APX		RG-52/U	UG-39/U and UG-40A/U	Type N Male	15	8.20 - 12.40 KMC
CU-479/APQ-39		RG-96/U	UG-599/U and UG-600		20	26.50 - 40.00 KMC
CU-484()/UP					10	
CU-485()/UP					10	
CU-515/FPS-19		RG-46/U	UG-49/U and UG-50/U	UG-58/U	20	
CU-516/FPS-20		RG-69/U	UG-418A/U	Type N Male	40	1.12 - 1.70 KMC
CU-528/U		RG-113/U	UG-554/U	Type N female	20	2.20 - 3.30 KMC
CU-529/MPS-16		RG-49/U	UG-148B/U and UG-149A/U	Type N female	37	3.95 - 5.85 KMC
CU-545/APN-1					20	
CU-549/TPS-1D		RG-69/U	UG-417A/U	Type N female	30	1.12 - 1.70 KMC
CU-556/FPS-6A		RG-75/U	UG-584/U and UG-585/U		18	2.60 - 3.95 KMC
CU-583/FPS-18				Type HNC		
CU-597/FPS-7				Type N	50	

1 See footnote at end of table.

DIRECTIONAL COUPLERS -- Continued

Type	Description	For use with	Primary line termination	Secondary line output	Coupling ^{1/} (db)	Engineering data
CU-606/GPS		RG-69/U	UG-418A/U	Type HN receptacle	23	1.12 - 1.70 KMC
CU-608/U		RG-153/U	UG-1163/U			
CU-609/U		RG-155/U	UG-1159/U			
CU-610/UR		RG-85A/U	UG-1170/U	End Seal		
CU-632/U				Type HN	50	
CU-652/UR			UG-560/U	Type HN	20	
CU-653/UR			UG-560/U	Type HN	20	
CU-662/GPQ-TIA			UG-571A/U	C Connector	40	
CU-673/U		RG-91/U	UG-541/U	Choke flange	10	
CU-681/GRN-9C			UG-290A/U	BNC Connector	30	
CU-682/GRN-9C			UG-290A/U	BNC Connector	40	
CU-721/TFN-12				Type N	25	
CU-730/U					28	
CU-733/APS-80						
CU-735/SPS-5C						
CU-739/SP		RG-218/U and RG-219/U	UG-155B/U	Type LC	40	
CU-742/FPN-34		RG-69/U	UG-417A/U	Type N female	56	1.12 - 1.70 KMC
CU-743/FPN-34		RG-69/U	UG-417A/U	Type N female	56	1.12 - 1.70 KMC
CU-767/FPS-35				Type N	68 74	
CU-773/URA-27			UG-560/U	Type HN	20	
CU-783/APW-22						
CU-785/GKA-5		RG-8/U and RG-9/U	UG-61E/U	Type HN		
CU-790/FPS-30					0	
CU-802/GKA-5			UG-1094/U	BNC Connector		
CU-817/FRT-49					60 to 90	
CU-820/URA-34			UG-560/U	Type HN		
CU-823/FPS-61		RG-69/U	UG-418A/U	Type HN Receptacle	30	1.12 - 1.70 KMC
CU-824/FPS-61		RG-69/U	UG-418A/U	Type HN Receptacle	30	1.12 - 1.70 KMC
CU-845/FRT-49				Type N	60 to 90	
CU-848/FPS-6					0.2	
CU-851/ALQ-23			UG-28A/U	Type N	3	
CU-852/ALQ-23				Type LT	40	

¹ See footnote at end of table.

MIL-HDBK-216
4 January 1962

DIRECTIONAL COUPLERS — Continued

Type	Description	For use with	Primary line termination	Secondary line output	Coupling ^{1/} (db)	Engineering data
CU-853/ALQ-23			UG-352B/U	Type LC	40	
CU-854/ALQ-23			UG-29B/U	Type N	48	
CU-857/UF				Type N	43.5	
CU-861()/U		RG-69/U	UG-418A/U	Type N	30	1.12 - 1.70 KMC

¹ Unless otherwise noted, the degree of coupling is the same for both incident and reflected waves in bidirectional couplers.

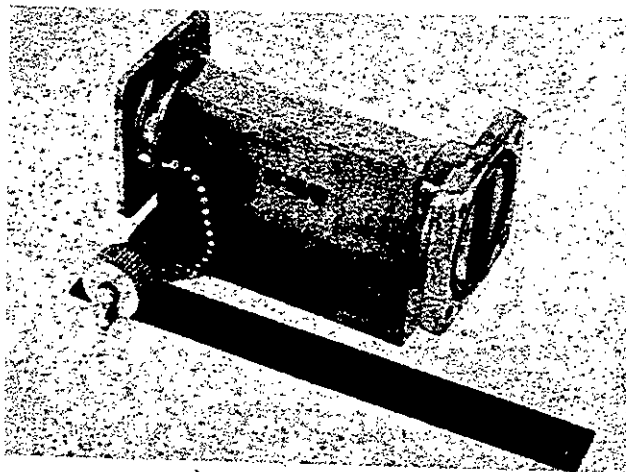

TYPICAL UNIDIRECTIONAL COUPLER

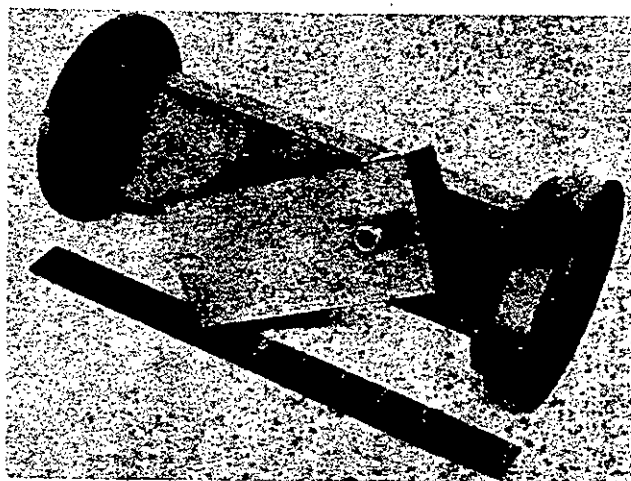

TYPICAL UNIDIRECTIONAL COUPLER

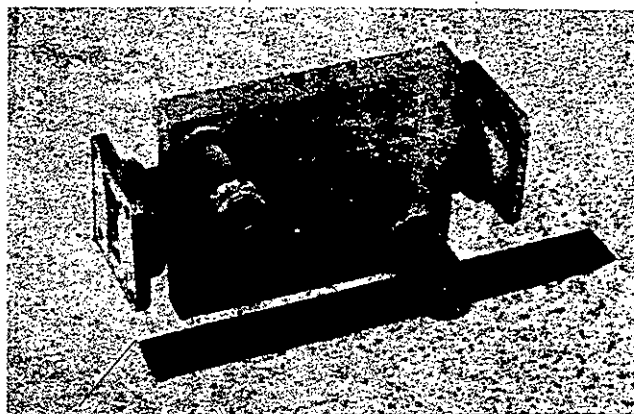

TYPICAL BIDIRECTIONAL COUPLER

MIL-HDBK-216
4 January 1962

SECTION 13

DUMMY LOADS

13-1 General considerations.

Dummy, or artificial loads, are available in the frequency range from 1.12 to 40 kmc. Each has a limited frequency range over which it provides a satisfactory match to the transmission line it terminates. Loads of various powers are available.

The devices usually consist of a resistance element in a shorted section which appears to the transmission line as an infinite line. When in use, the specified average power, and the peak power at any one frequency, should not be exceeded.

13-2 Table.

The loads listed in this part are those commonly used by the Armed Services.

MIL-HDBK-216
4 January 1962

DUMMY LOADS

TYPE	FRE- QUEN- CY (kmc/sec)	FOR USE WITH	TERMINA- TION	AVER- AGE POWER (Watts)	PEAK POWER (lowest to high- est frequency)	ENGINEERING DATA
DA-6/U	8.50-9.60	RG-52/U	UG-40/U	200	300 kw	See note
DA-7/UP	7.05-10.00	3/8 coax	UG-23B/U	1	1 kw	Max. VSWR 1.1
DA-8/UP	5.65-7.05	3/8 coax	UG-23B/U	1	1 kw	Max. VSWR 1.1
DA-9/UP	4.00-5.65	7/8 coax	UG-23B/U	1	1 kw	Max. VSWR 1.1
DA-10/UP	5.65-7.05	RG-76/U	UG-141/U	1	1 kw	Max. VSWR 1.1
DA-11/UP	4.00-5.65	RG-76/U	UG-141/U	1	1 kw	Max. VSWR 1.1
DA-45/UP	20-440	3/8 coax	N Male	1	1 kw	
DA-55/U	12.4-18.0	RG-69/U	UG-419/U	100	.28 megawatt	VSWR 1.10:1
DA-77/U	1.70-2.60	RG-104/U	UG-435A/U	1	1 kw	
DA-81/U	.925-3.95	7/8 coax	UG-46/U	1	1 kw	
DA-82/U	.1-1.7	1-5/8 coax	UG-50/U	1	1 kw	
DA-99/SLT	.015-2.70	RG-128/U	UG-677/U		1 kw	Max. VSWR 1.2
DA-102/UPM-63	15.7-17.0	RG-91/U	UG-419/U	1	1 kw	VSWR<5.0:1
DA-111/UPM-12	8.50-9.60	RG-52/U	UG-39/U			Calibrated mismatch
DA-141/U	2.60-3.95	RG-48/U	UG-53/U	1	1 kw	VSWR<1.01:1
DA-142/U	3.95-5.85	RG-49/U	UG-149A/U	1	1 kw	VSWR<1.01:1
DA-143/U	8.20-12.0	RG-52/U	UG-39/U	1	1 kw	VSWR<1.01:1
DA-144/U ¹	3.85-8.20	RG-106/U	UG-440A/U	800	.710 megawatt	VSWR<1.10:1
DA-145/U ¹	2.60-3.95	RG-75/U	UG-584/U	4500	3.20 megawatt	VSWR<1.10:1
DA-146/U ¹	8.30-12.4	RG-67/U	UG-136A/U	500	.290 megawatt	VSWR<1.10:1
DA-147/U ¹	1.12-1.70	RG-103/U	UG-418A/U	4500	17.2 megawatt	VSWR<1.10:1
DA-148/U ¹	7.08-10.0	RG-68/U	UG-137A/U	600	.460 megawatt	VSWR<1.10:1
DA-149/U ¹	3.95-5.85	RG-95/U	UG-406A/U	2000	2.00 megawatt	VSWR<1.10:1
EA-154/U	1.00-4.00	Rigid guide		1	1 kw	
DA-158/U ¹	26.5-40.0	RG-96/U	UG-599/U	75	.100 megawatt	VSWR<1.15:1
DA-159/U ¹	12.4-18.0	RG-107/U	UG-419/U	250	.160 megawatt	VSWR<1.15:1
DA-160/U ¹	18.0-26.5	RG-121/U	UG-597/U	150	.125 megawatt	VSWR<1.15:1
CG-97/AP	1.55-5.20	RG-155/U	UG-46/U			Used in eqpt. AN/AP A-22
TS-74A/UPM	1.55-5.20	7/8 coax	UG-45 and -46/U	200	250 kw	Similar to TS-105/ TPM-1. Terminates in 50 & 72 ohm lines
TS-105/TPM-1	0.39-1.65	1-5/8 coax		200	250 kw	Used in eqpt. AN/TPM-1

¹ Requirements in accordance with Specification MIL-D-3954.

Note: This component is not recommended for use over the entire frequency range of the associated waveguide due to the dummy load termination.

TYPICAL WAVEGUIDE DUMMY LOAD

FIGURE 1

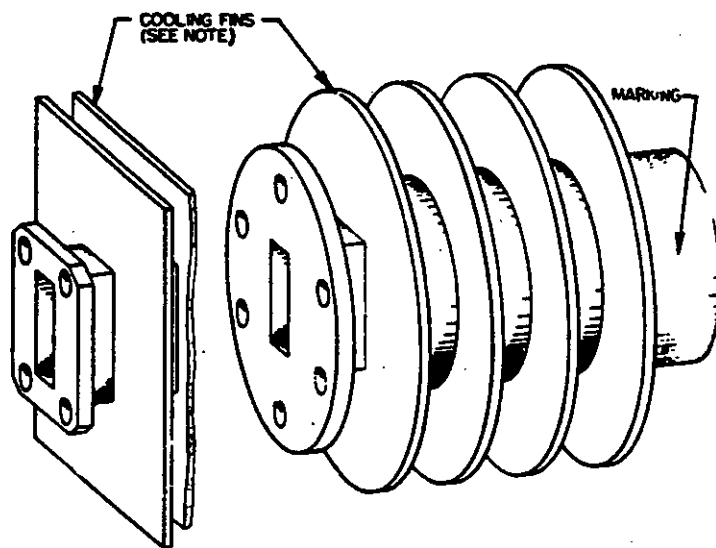

NOTE: Cooling fins may be rectangular or circular.

SECTION 14A

ATTENUATORS

14.1 General consideration.

14.1.1 Definition. An attenuator is a linear, passive device (with the exception of the pin diode type) designated to reduce (attenuate) power in a system by a predetermined ratio.

14.1.2 Application. Attenuators are used in many applications in the electronics field. Attenuators are used:

- (a) In loss measurements, where a known attenuator(s) is used to evaluate or measure an unknown loss or gain by comparison.
- (b) To extend the dynamic range of equipments and prevent burn-out or overloading of equipments.
- (c) To prevent interaction between circuit elements or circuits.

14.1.3 Types. There are two basic types of attenuators; fixed and variable, (mechanical and electrical). They include waveguide, coaxial, and printed circuit connections, absorptive and reflective, and calibrated and uncalibrated versions.

14.1.3.1 Fixed. Fixed attenuators are generally of six types:

- (a) Waveguide vane types, broad band and low power attenuators, are capable of high precision.
- (b) Rotated vane attenuators use the rotary vane principle in a fixed position. These are normally high value attenuators with good stability and precision.
- (c) Directional coupler types are similar in design to precision multihole directional couplers with attenuation a function of the coupling hole array between two lines. This type has a low voltage standing wave ratio (VSWR) since there are no protrusions into the waveguides. They are useful for higher attenuation values, high power levels, and as attenuation standards.
- (d) The "T" or "pi" attenuators have matching provisions to make the input impedance equal to the characteristic impedance of the line. The maximum and minimum value of attenuation are determined by the number of sections that are used and the available range of resistance values. The "T" and "pi" attenuators are normally used at lower frequency (6 GHz or less). The upper frequency is limited by the physical size of the resistive element and the mechanical movement. At higher frequencies the size of the element becomes comparable to the wavelength, consequently a point is reached when the element can no longer be considered as lumped components but rather a transmission line.
- (e) Lossy line attenuators (reference MIL-A-3933) are generally used from 1.0 to 18 GHz since they exhibit a low frequency cut off based on length and value of attenuation.
- (f) Distributed resistive film on a card of substrate attenuators are relatively frequency insensitive and are used from dc to 26.5 GHz. They offer good average power handling characteristics.

MIL-HDBK-216
SECTION 14A
8 November 1976

14.1.3.2 Variable. Variable attenuators are uncalibrated or calibrated with read out on scales, dials, micrometers, digital display or no readout but with thumb or screwdriver adjustments. These attenuators are generally of five basic types:

- (a) Lossy material types are those where microwave power flows through the material and are attenuated. Attenuation is varied by mechanically varying the location of the lossy material with respect to the media that conducts or propagates microwave power. Two of the many varieties of this type of attenuator are as follows:
 - (1) Lossy wall. The attenuation of a lossy wall attenuator is varied by changing the position of the material with respect to the coaxial fixed center conductor. Because of the lossy material, this item is frequency sensitive and has limited power handling capability; however, it has low insertion loss and low VSWR.
 - (2) Moveable vane. These are normally used in waveguide applications. With a given lossy material on the vane, the distance between the vane and waveguide side walls will cause the attenuation to vary. The vane is mounted inside the waveguide on rods that pass through holes in either the broadwall or narrow wall. These are frequency sensitive, low power, low insertion loss, and low VSWR attenuators.
- (b) Waveguide-below-cutoff. One of the most accurate variable attenuators is the waveguide-below-cutoff type. These are generally designed in the cylindrical waveguide configuration using the TE₁₁ mode of propagation. The attenuation is varied by changing the axial distance between two loops within the waveguide. With the exception of an initial nonlinear region, the change in attenuation is linear as a function of the distance between the loops. This type of attenuator normally has a higher insertion loss than other types; however, it has a wide attenuation range with satisfactory frequency sensitivity and VSWR rating in the linear region of operation.
- (c) Step attenuators (turret). Normally, step attenuators are used in applications requiring broadband flatness with low VSWR and satisfactory resettability over ranges from 0 to 120 dB. These use fixed attenuators arranged in a rotatable drum configuration or in a slab for switching between contacts. This arrangement provides discrete values of attenuation in each position and a high reliability factor. The majority of the step attenuators are useful from dc to 18 GHz.
- (d) Variable coupling attenuators. The attenuation of variable coupling attenuators is a function of the axial spacing or angular position between coupling sections. Two varieties of this type of attenuator are as follows:
 - (1) Variable coupler. These are basically directional couplers where the attenuation is varied by mechanically changing the coupling between two sections. This is accomplished by varying the spacing between coupled lines. These attenuators have a large attenuation range, high power handling capability, and retain calibration over a range of ambient conditions. They have a higher insertion loss when used at lower frequencies.
 - (2) Rotary vane. These attenuators normally consist of three sections of waveguide in tandem. The resistive material of the sections is normal to the E-field of the applied signal. The two end sections are fixed and the middle section is free to rotate with respect to the other two sections. Attenuation is varied by changing the angle of the resistive material with respect to the material of the end sections. When all resistive materials are aligned, no attenuation occurs. Maximum attenuation is normally

limited to 60 dB in order to avoid nonlinearities. These attenuators are accurate for wideband waveguide applications.

- (e) A distributed resistive film on a card or substrate type attenuator which has a moving brush or contact element provides an attenuation range of up to 120 dB. They are similar in design to a potentiometer. These types are available from dc to about 4 GHz at present.
- (f) Programmable attenuators. These rapid switching attenuators with high accuracy and repeatability, are useful in remote and computerized applications. Units are available with a switching speed of 30 nanoseconds. Two varieties of the programmable attenuators are the step and voltage controlled. The attenuation is varied by controlling the electrical signal applied to the attenuator. These signals can either be in the form of a biasing current or binary digit. The biasing can be pulses, square waves, or sine waves.

14.2 Electrical parameters and definitions.

14.2.1 Attenuation. A general transmission term used to indicate a decrease in signal magnitude. This decrease in power is commonly expressed in the logarithmic term of decibel that is equal to $10 \text{ Log } 10 \frac{P_{\text{input}}}{P_{\text{output}}}$.

14.2.2 Deviation of attenuation from nominal. This is the difference in actual attenuation from the nominal value of 23°C and an input power of 10 milliwatts at a specified reference frequency or frequency range. When specified for a frequency range, this also includes the frequency sensitivity variation (see 14.2.7) of the attenuator.

14.2.3 Characteristic insertion loss. This is the insertion loss (see 14.2.8) in a transmission line or waveguide that is reflectionless in both directions from the inserted attenuator.

14.2.4 Characteristic insertion loss incremental. This is the change in the characteristic insertion loss of a variable attenuator between two settings.

14.2.5 Characteristic insertion loss residual. (insertion loss residual). This is the loss through a variable attenuator when it is adjusted to the indicated minimum setting.

14.2.6 Frequency range. This is the range over which the accuracy of the attenuator is specified.

14.2.7 Frequency sensitivity. This is the peak-to-peak variation in the loss of the attenuator through the specified frequency range.

14.2.8 Insertion loss. This is the amount of power loss from the insertion of the attenuator in the transmission system. It is expressed as a ratio of the power delivered to that part of the system following the attenuator, before and after the insertion.

14.2.9 Power handling capabilities. This is the maximum power that can be applied to the attenuator under specified conditions and durations without producing a permanent change in the performance characteristics that would be outside of specification limits.

14.2.10 Maximum average power. This is the maximum average input that can be applied to the attenuator for a minimum of 1 hour at the maximum operating temperature without producing a permanent change in the specified properties.

14.2.11 Maximum peak power. This is the maximum peak input at maximum pulse length that can be applied to the attenuator for a minimum of 1 hour at the maximum operating temperature without producing a permanent change in the specified properties.

MIL-HDBK-216
SECTION 14A
8 November 1976

14.2.12 Power sensitivity. This is the temporary variation (under steady state conditions) in attenuation (in dB/W) when the input power is varied from 10 milliwatts to maximum input power.

14.2.13 Stability of attenuation. This is the stability of an attenuator after it has been subjected to various environmental requirements.

14.2.14 Operating temperature range. This is the temperature range that the attenuator can be operated at with maximum input power.

14.2.15 Temperature sensitivity. This is the temporary variation in attenuation
dB
(dB x °C) over the operating temperature range.

14.2.16 Input voltage standing wave ratio. This is the level of reflected signal created at the attenuator input when the output is terminated with a load with the same characteristic impedance as the radio frequency source.

14.2.17 Output voltage standing wave ratio. This is the level of reflected signal created at the attenuator output when the input is terminated with a load with the same characteristic impedance as the radio frequency source.

14.3 Tables. The following tables pertain to fixed attenuators approved as nonstandard parts, and variable attenuators (mechanical) approved as nonstandard parts.

TABLE 14. I. Fixed attenuators approved as nonstandard parts.

Equip part or dwg. no.	Frequency range <u>GHz</u>	Attenuation <u>dB</u>	Power AVG <u>W</u>	VSWR	Termination
0019346-01	1.15	10 \pm 0.6	50	1.20:1	Serie N, male (2)
2132441-1	1.06	5.4 \pm 0.3	20	1.20:1	Serie N, male & female
2132440-1	1.06	7 \pm 0.3	5	-	Serie N, male & female
10-00393	dc to 2.0	60 \pm 1.0	2	1.25:1	TNC, male & female
118858	dc to 4.0	10 \pm 0.5	15	1.25:1	TNC, male & female
2372423G1	0.95 to 1.225	1 \pm 0.3	2	-	TNC, male & female
339709-1	dc to 2	20 \pm 2	1	1.50:1	TNC, male & female
G 300111	dc to 4	1 \pm 0.25	1	1.25:1	BNC, male & female
0019368-01	1.025 to 1.15	40 \pm 1.0	5	1.20:1	SMA, female (2)
2899271	dc to 5	3 \pm 0.3	2	1.25:1	SMA, male & female
2899271-1	dc to 5	6 \pm 0.3	2	1.25:1	
2899271-2	dc to 5	10 \pm 0.5	2	1.25:1	
2899271-3	dc to 5	20 \pm 0.5	2	1.25:1	
2899271-4	3 to 3.6	14 \pm 0.3	2	1.25:1	
2899271-5	3 to 3.6	2 \pm 0.2	2	1.25:1	
2899271-6	3 to 3.6	1 \pm 0.2	2	1.25:1	
2899271-7	dc to 4	9 \pm 0.5	2	1.25:1	
2899271-8	dc to 4	12 \pm 0.5	2	1.25:1	
37-808602-1	1 to 2	2 \pm 0.2	2	1.50:1	SMA, male
37-808602-2	2 to 4	4 \pm 0.2	1	1.50:1	
37-808602-3	2 to 4	2.5 \pm 0.1	1	1.50:1	
37-808602-4	4 to 8	2 \pm 0.2	1	1.50:1	
373376-1	dc to 12	3 \pm 0.3	2	1.25:1	SMA, male & female
373376-2		4 \pm 0.3			
373376-3		5 \pm 0.3			
373376-4		6 \pm 0.3			
373376-5		7 \pm 0.3			
373376-6		8 \pm 0.3			

MIL-HDBK-216
SECTION 14A
8 November 1976

TABLE 14.1 Fixed attenuators approved as nonstandard parts -Continued.

Equip part no. dwg. no.	Frequency range GHz	Attenuation dB	Power AVG W	VSWR	Termination
373376-7	dc to 12	9 +0.3	2	1.25:1	SMA, male & female
373376-8		10 +0.3			
373376-9		12 +0.5			
373376-10		15 +0.5			
373376-11		17 +0.5			
373376-12		20 +0.5			
373376-14	dc to 12	1 +0.3	2	1.25:1	SMA, male & female
373376-15		2 +0.3			
R364905		20 +0.6			
581R199H09		15 +1.0			
PT4-13063-001		0.1 +0.25			
-005	7 to 8.5	0.5 +0.25	2	1.30:1	SMA, male & female
-010		1 +0.25			
-015		1.5 +0.25			
-020		2 +0.25			
-025		2.5 +0.25			
-030		3 +0.25			
-035		3.5 +0.25			
-040		4 +0.25			
-045		4.5 +0.25			
-050		5 +0.25			
-055		5.5 +0.25			
-060		6 +0.25			
-065		6.5 +0.25			
-070		7 +0.25			
-075	7.5 +0.25				
-080	8 +0.25				
-085	8.5 +0.25				
PT4-13063-090	9 +0.25				

TABLE 14. I. Fixed attenuators approved as nonstandard parts. -Continued.

Equip part no. dwg. no.	Frequency range	Attenuation dB	Power AVG	VSWR	Termination
PT4-13063-095	7.2 to 7.9 GHz	9.5 +0.25	2	1.20:1	SMA, male & female
-100		10 +0.25			
-105		10.5 +0.25			
-110		11.0 +0.25			
-115		11.5 +0.25			
-120		12 +0.25			
-125		12.5 +0.25			
-130		13 +0.25			
-135		13.5 +0.25			
-140		14 +0.25			
-145	14.5 +0.25				
PT4-13063-150	7.2 to 7.9 dc to 3	15 +0.25	2	1.20:1	SMA, male & female
8P032-001		0.5 +0.25			
-002	dc to 3	1 +0.25	2	1.15:1	SMA, male & female
-003		1.5 +0.25			
-004		2 +0.25			
-005		2.5 +0.25			
8P032-006		3 +0.25			
2903816-1	dc to 1 dc to 2 dc to 12	1 +0.5	5	1.15:1	SMA, male & female
2903816-2		2 +0.5			
1133152		3 +0.25			
1171896		10 +0.5			
A-002008-1		10 + 0.5			
A-002008-2		20 +0.5			
11041152		8 +0.5			
469881-1		1 +0.5			
-2		2 +0.5			
-3		3 + 0.5			
-4	4 +0.5				
-5	5 +0.5				
-6	6 +0.5				
-7	7 +0.5				
-8	8 +0.5				
-9	9 +0.5				
-10	10 +0.5				
					Solder tabs Solder tabs Solder leads

MIL-HDBK-216
SECTION 14A
8 November 1976

TABLE 14.I. Fixed attenuators approved as nonstandard parts -Continued.

Equip part no. dwg. no.	Frequency range	Attenuation dB	Power AVG	VSWR	Termination
469881-11	dc to 12 GHz	11 ± 0.55	W 1	1.35:1	Solder leads
-12		12 ± 0.6			
-13		13 ± 0.65			
-14		14 ± 0.7			
-15		15 ± 0.75			
-16		16 ± 0.8			
-17		17 ± 0.85			
-18		18 ± 0.9			
-19		19 ± 0.95			
-20		20 ± 1.0			
469881-20		dc to 12 dc to 1 GHz			
717754-1	2 ± 0.2				
717754-2	3 ± 0.3				
-3	4 ± 0.4				
-4	5 ± 0.5				
-5	6 ± 0.6				
-6	7 ± 0.7				
-7	8 ± 0.8				
-8	9 ± 0.9				
-9	10 ± 1.0				
-10	11 ± 1.1				
-11	12 ± 1.2				
-12	13 ± 1.3				
-13	14 ± 1.4				
-14	15 ± 1.5				
-15	16 ± 1.6				
-16	17 ± 1.7				
-17	18 ± 1.8				
-18	19 ± 1.9				
-19	20 ± 2				
-20					

TABLE 14. I. Fixed attenuators approved as nonstandard parts -Continued.

Equip part no. dwg. no.	Frequency range	Attenuation	Power AVG	VSWR	Termination
717754-21	dc to 1	21 +2	W	-	PC
-22		22 +2	0.1		
-23		23 +2			
-24		24 +2			
-25		25 +2			
-26		26 +2			
-27		27 +2			
-28		28 +2			
-29		29 +2			
-30		30 +2			
-31		31 +2			
-32		32 +2			
-33		33 +2			
-34		34 +2			
-35		35 +2			
-36		36 +2			
-37		37 +2			
-38		38 +2			
-39		39 +2			
-40		40 +2			
8998799	dc to 1	20 +0.5	0.1	-	PC
251835	8.2 to 12.4	10 +0.2	10	1.20:1	Waveguide flanges
2132514-1	8.2 to 12.4	30 +0.2	2	1.15:1	
.584121-1	7.05 to 10.0	18 +0.2	15	1.15:1	
584121-2	12.4 to 18.0	12 +0.2	1	1.20:1	Waveguide flanges

MIL-HDBK-216
SECTION 14A
November 1976

TABLE 14. II. Variable attenuators (mechanical) approved as nonstandard parts.

Equip part or dwg. no.	Freq range	Atten range	Dial backlash	VSWR (max)	Insertion loss	Calibration accuracy	Frequency sensitivity	Power avg	Termination
145266	GHz 0.4-0.45	(step) 0-60	-	1.70:1	dB 0.3	dB +0.5	-	W 0.5	Serie N, female (2)
SM-A-571563	0.06-0.08	(step) 0-41	-	-	0.5	-	-	0.1	Serie N, female (2)
01P222260	0.5-8	(step) 0.5-67	-	1.50:1	0.5	-	-	10	Serie N, female (2)
788C322H01	dc-2	(step) 0-5	-	1.25:1	-	+0.5	-	2	Serie N, male & female
H02		(step) 0-10	-		-	+0.5	-		
H03		(step) 0-20	-		-	+1.0	-		
788C322H04	dc-2	(step) 0-25	-	1.25:1	-	+1.0	-	2	Serie N, male & female
1087	0.052-0.056	(step) 0-10	-	1.30:1	1.0	+1.0	-	1	TNC, male & female
5518438	dc-1.2	(step) 0-100	-	1.20:1	0.3	+1.0	+4.0 dB	1	TNC, female (2)
5518437	dc-2.0	(step) 0-10	-	1.50:1	0.5	+0.1	+0.4 dB	1	TNC, female (2)
118851	dc-2.0	(step) 0-70	-	1.50:1	0.5	+0.2	+1.8 dB	1	TNC, female (2)
026-155-5382-000	dc-2.0	(step) 0-10	-	1.50:1	0.1	+0.1	+0.4 dB	1	TNC, female (2)
7844025	dc-0.010	(step) 0-20	0.1	1.20:1	0.5	-	-	1	BNC, female (2)
C12442	0-0.5	(step) 0-12	-	1.20:1	0.1	+0.1	-	0.5	BNC, female (2)
C12438	0-0.5	(step) 0-70	-	1.20:1	0.1	+0.1	-	0.5	
149225	0-0.5	(step) 0-10	-	1.20:1	0.1	+0.1	-	0.5	
0484	0.052-0.056	(step) 0-25	-	1.50:1	1	-	+5%	1	
20-106955	dc-1.7	(step) 0-85	-	1.20:1	0.3	+0.2	+1.8 dB	0.5	
20A0243002	dc-1	(step) 0-70	-	1.50:1	0.3	+0.2	+0.8 dB	0.5	BNC, female (2)

TABLE 14.II. Variable attenuators (mechanical) approved as nonstandard parts -Continued.

Equip part or dwg. no.	Freq range GHz	Atten range dB	Dial backlash dB	VSWR (max)	Insertion loss dB	Calibration accuracy dB	Frequency sensitivity dB	Power avg W	Termination
20A0243001	dc-1	(step) 0-10	-	1.50:1	0.3	+0.1	+0.4 dB	1	BNC, female (2)
G300010S1	dc-0.050	(step) 6-21	-	1.35:1	-	+0.7	-	2	
G300010S2	dc-0.050	(step) 3-18	-	1.35:1	-	+0.6	-	2	
G300010S3	dc-0.050	(step) 0-15	-	1.35:1	-	+0.6	-	2	
10272609-1	0.050-0.070	(step) 0-10	-	1.10:1	0.25	+0.1	-	0.5	
G300304-	dc-4	(step) 0-69	-	1.25:1	0.5	+1.30 69 dB	-	2	SMA, female (2)
582R376H01	2-4	0-10	-	1.70:1	1.2	-	+2 dB	1	
134204-001	.925-1.225	0-100	+0.5	1.80:1	6	+0.75% or +0.25	-	2	
134204-002	.925-1.225	0-60	+0.5	1.80:1	6	+0.75% or +0.25	-	2	
134204-003	1-1.12	0-100	+0.5	1.80:1	6	+0.75% or +0.25	-	2	
134204-004	1-1.12	0-63	+0.5	1.80:1	6	+0.75% or +0.25	-	2	
0019351	.925-1.225	(step) 0-100	-	1.30:1	0.7	+2	+0.2 dB	1	
AC9003-49	dc-4	(step) 0-49	-	1.35:1	0.5	+1.3	-	0.5	
378-0626-010	dc-2	0-10	-	1.35:1	0.8	+0.4	-	1	
58-P04933G-001	4-8	0-10	-	1.50:1	0.5	-	-	5	
58-P07581G-001	4.4-4.8	0-120	-	1.50:1	1	+1.5	-	5	
1254	1.03	0-60	-	2:1	6	+0.5	-	1	
723799	dc-0.5	0-11	-	1.15:1	-	+0.5	-	1	
03-808541	dc-0.5	1-16	-	1.20:1	1	+0.5	-	0.5	
37-808573	dc-0.3	0-65	-	1.25:1	6	+0.1	-	0.1	
725016A0467	0.065 -0.085	(step) 0-50	-	1.20:1	0.3	+0.5	-	0.5	SMA, female (2)

MIL-HDBK-216
SECTION 14A
8 November 1976

TABLE 14.II. Variable attenuators (mechanical) approved as nonstandard parts -Continued.

Equip part or dwg. no.	Freq range	Atten range	Dial backlash	VSWR (max)	Insertion loss	Calibration accuracy	Frequency sensitivity	Power avg	Termination
228089	0.5-8	0-55	-	1.50:1	0.5	-	dB	W	SMA, female (2)
725016A0389	.28357	0-10	-	1.50:1	1.5	-	-	10	SMA, female (2)
2938947	-.28643	0-25	-	1.50:1	1.0	-	+1 dB	0.5	SMA, female (2)
77C712525	-.0345	0-10	-	2.0:1	2.0	-	-	0.5	
G300310	dc-0.4	0-40	-	1.50:1	0.5	-	-	2	
119986	2-12.4	0-60	-	1.10:1	0.4	+0.9	-	1	
721776	1.370	0-20	-	1.60:1	0.5	-	-	5	
2902527	11.0-	0-2	-	1.20:1	0.2	-	-	40	
7011-0512	17.0	0-15	-	1.40:1	0.5	-	+1 dB	2	
37-808602-6	0.656	1-4.5	-	1.50:1	0.4	-	+0.4 dB	1	SMA, female (2)
37-808602-7	8.75	1-2.5	-	1.50:1	0.5	-	+0.2 dB	1	PC
725016A0773	-9.6	0-15	-	1.50:1	1.5	+0.2	-	0.5	PC
77C712498	dc-0.225	0-15	-	1.30:1	1.5	-	-	0.5	PC
58-P18369B001	33-33.4	20-60	-	-	-	-	-	10	Waveguide

SECTION 15

ROTARY JOINTS

15-1 General considerations.

As a result of the lack of coordination in the past, a wide variety of rotary joints have been designed, each specific to a particular piece of equipment.

Air-dielectric rotary joints include single coaxial and double concentric coaxial systems, with the single coaxial units including 50- and 70-ohm characteristic impedance types.

Solid-dielectric rotary joints were developed for radar systems which use solid-dielectric R. F. Cables to supply R. F. signals to the antenna. The solid dielectric rotary joint eliminates the necessity of pressurizing or dehydrating an air-dielectric type rotary joint.

15-2 Tables.

This part lists the rotary joints used by the Armed Services. The single rotary joints are used for transmission of frequencies and voltages which are limited only by the accessory cables and connectors in the line. The duplex are used for the specific band or frequency of the equipment noted.

MIL-HDBK-216
4 January 1962

A

SOLID-DIELECTRIC ROTARY JOINTS

Type	Description	Figure No.	For use with cable types	Weather-proof	Engineering data
UG-162/U	Single	15-A	RG-17, 18/U	Yes	See note 1
UG-226/U	Single	15-B	RG-17, 18/U	Yes	See note 1
UG-227/U	Duplex		RG-8, 10, 19, 20/U	Yes	See note 2
UG-238/U	Duplex		RG-8, 10, 19, 20/U	Yes	See note 2
UG-308/U	Single		RG-8, 10/U-		See note 3
UG-916/U	Single		All cables used with Series N Connectors	Yes	Pressurized; Series N Plug on one end, Series N Jack on other end
	Single		RG-8 size R. F. cable	Yes	See note 4
	Single		RG-8 size R. F. cable	Yes	See note 5

NOTE 1: Terminates in type LC female fitting at both ends. Can be used with other cables by use of suitable adapters.

NOTE 2: Terminates in type LC and HN female fittings at both ends. Silicone liquid filled.

NOTE 3: Terminates in type HN female fitting on one end and a special fitting on the other end.

NOTE 4: Terminates in type N female fittings at both ends. Can be used with other cables by use of suitable adapters.

NOTE 5: Terminates in type HN female fittings at both ends. Can be used with other cables by use of suitable adapters.

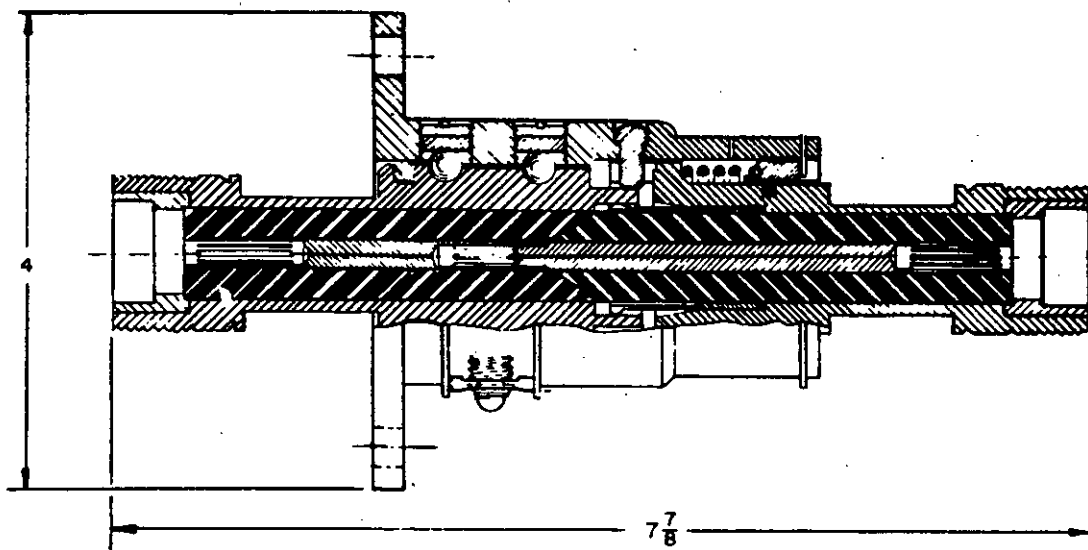

FIGURE 15-A

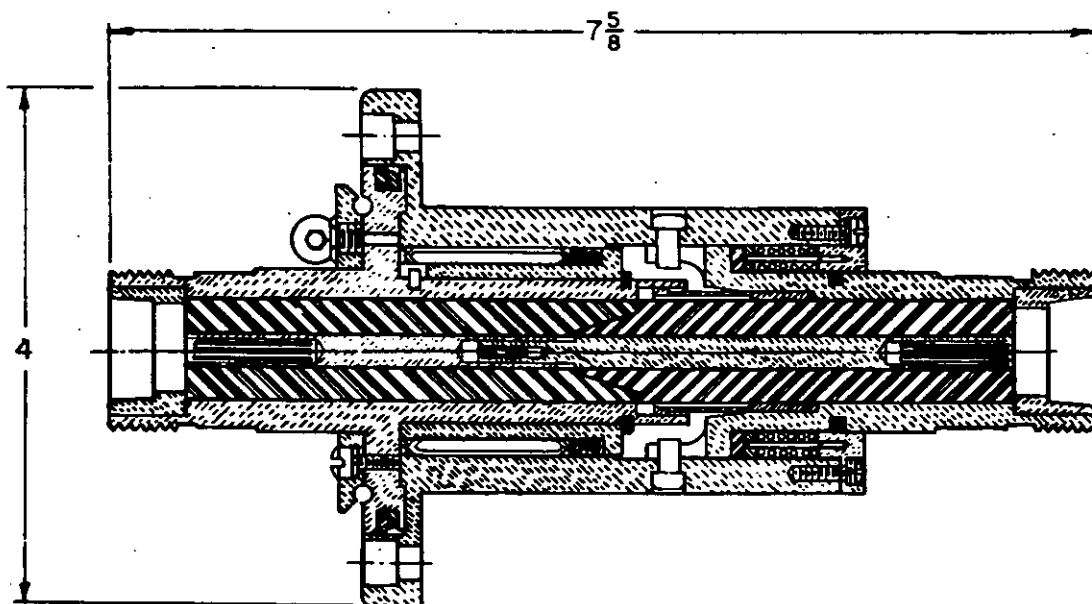

FIGURE 15-B

NOTE: ALL DIMENSIONS ARE APPROX. TO THE NEAREST $\frac{1}{8}$ INCH.

L-EDK-216
4 January 1962

B

AIR-DIELECTRIC ROTARY JOINTS

Type	For radar	Figure No.	For use with	Engineering data
	SC SC-1	15-C	1-5/8-inch line	
	SC-2 to SC-5 Inclusive	15-C	1-5/8-inch line	
	SA, SA-2 SA-3	15-C	1-5/8-inch line	
	SA-1	15-C	1-5/8-inch line	
	SCR-527	15-C	1-5/8-inch line	
	SCR-627	15-C	1-5/8-inch line	Azimuth elevation
	SCR-296A	15-D	1-5/8-inch line	
	Mark 20, model 0	15-E	1-5/8-inch line	Azimuth elevation
	Mark 20, model 0	15-E	1-5/8-inch line	Azimuth elevation
	AN/TPS-1 AN/TPS-1A	15-E	1-5/8-inch line	
	AN/TPS-1B	15-E	1-5/8-inch line	
	SCR-545	15-F	1-5/8-inch line	Azimuth elevation
	Mark 12	15-G	1-5/8-inch line	Cross-level elevation
	SD-3	15-H	1-5/8-inch line	
	SR-2	15-I	1-5/8-inch line	
	SK	15-J	3-1/8-inch line	
	SK-1M	15-J	3-1/8-inch top; 2-1/2-inch bottom line	
	SK-2 SK-3	15-J	3-1/8-inch line	
	SH SH-1	15-K	7/8-inch line	Cross-level elevation
	SC pedestal modified to use FC and B1 antennas	15-I	7/8-inch line	
	Mark 3 Mark 4	15-L	7/8-inch line	
	SCR-682	15-M	RG-28/U	DC pulse
	AM/CPS-4 SCR-598	15-M	RG-27, 28/U	DC pulse

MIL-HDBK-216
4 January 1962

AIR-DIELECTRIC ROTARY JOINTS -- Continued

Type	For radar	Figure No.	For use with	Engineering data
UG-325/U	AM/CPX-11		RG-10, 18/U	Dual coaxial
UG-346/U			RG-52/U	0.27 MW
UG-351/U	AM/MPW-3		7/8-inch line	Capacity coupled
UG-549/U	SR-3			4KV
UG-686/TPS-10D	AN-/TPS-10D		RG-52/U	9,200 to 9,400 Megacycles
UG-645/U	SG-6B			
UG-985/FPS-8	AN/FPS-8			

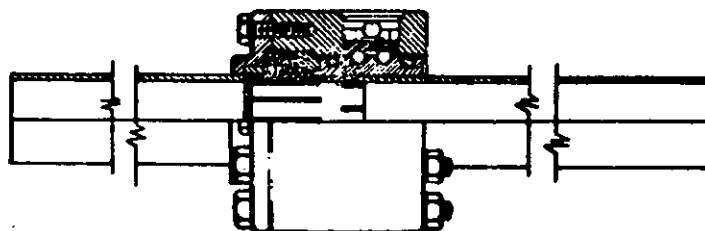

FIGURE 15-C

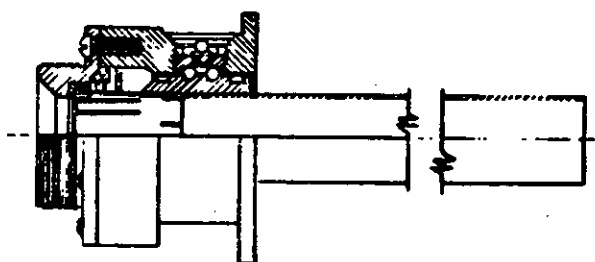

FIGURE 15-D

MIL-HDBK-216
4 January 1962

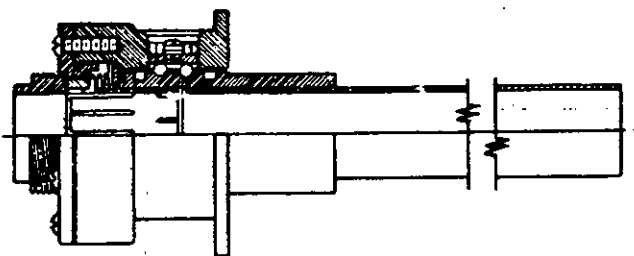

FIGURE 15-B

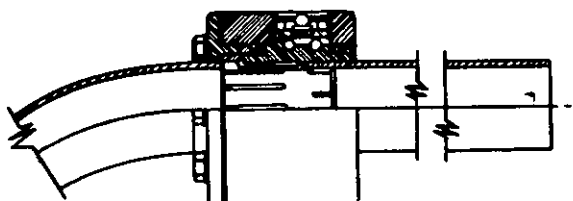

FIGURE 15-F

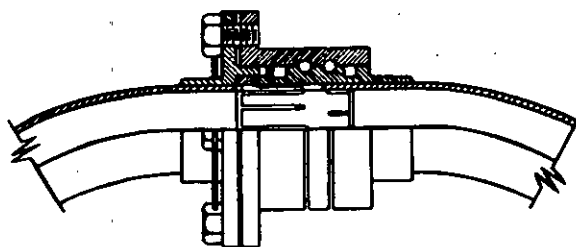

FIGURE 15-G

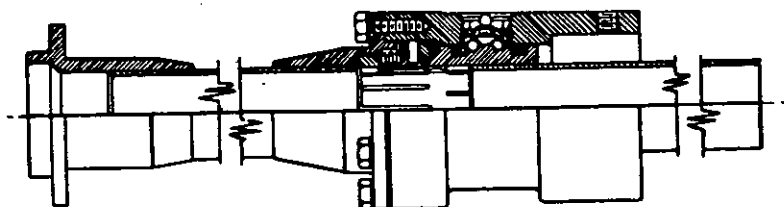

FIGURE 15-H

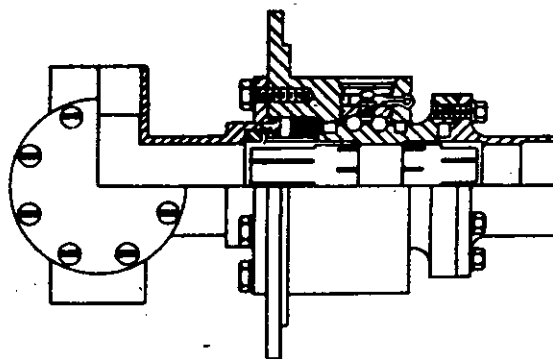

FIGURE 15-I

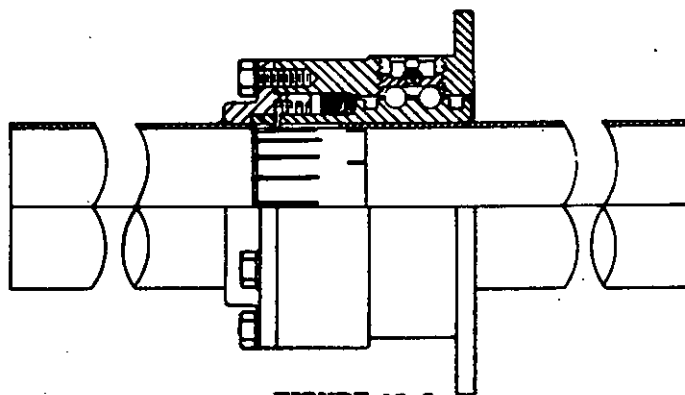

FIGURE 15-J

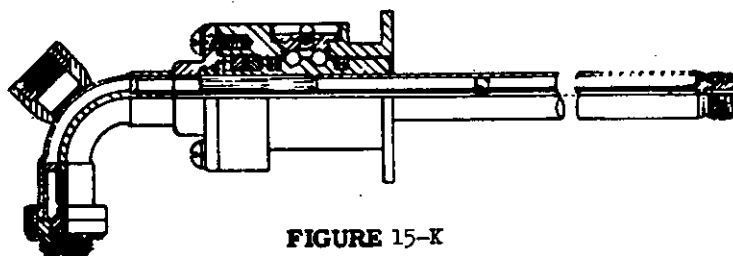

FIGURE 15-K

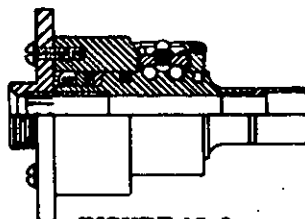

FIGURE 15-L

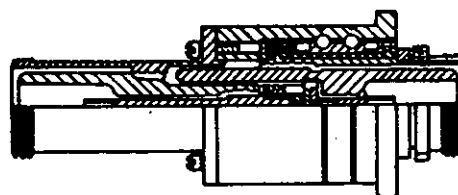

FIGURE 15-M

SECTION 16

MISCELLANEOUS NAVAL LINES AND FITTINGS

This section comprises lists of transmission lines, fittings, and associated equipment which have been prepared principally for the convenience of Naval activities. The lists were compiled by the Naval Research Laboratory and contain components shown on pertinent drawings. The drawings and specifications may be obtained upon application to the Director, Naval Research Laboratory,

1/4-INCH O. D. COAXIAL LINES (70-OHM, GAS-FILLED)

Item	Navy type	Navy drawing	Part No.
Installation instruction - - -	- - -	RA-62A-234	- - -
Spit-ring connector - - - - -	- - -	RA-62A-234	* 1
Compression nut - - - - -	- - -	RA-62A-234	2
Inner-conductor sleeve - - - -	- - -	RA-62A-234	3
Deck or bulkhead sleeve - - - -	- - -	RA-62A-234	4
Deck-sleeve nut - - - - -	- - -	RA-62A-234	5
Spit-sleeve member - - - - -	- - -	RA-62A-234	6
Coaxial line - - - - -	- - -	RA-62A-234	21
Protective armor - - - - -	- - -	RA-62A-234	22
Gland and follower - - - - -	- - -	RA-62A-234	23
Box connector - - - - -	- - -	RA-62A-234	25
Neoprene gland - - - - -	- - -	RA-62A-234	26
Ceramic plug - - - - -	- - -	RA-62A-234	27
Tee connector - - - - -	- - -	RA-62A-234	28
Pipe cap - - - - -	- - -	RA-62A-234	29
End seal - - - - -	- - -	RA-62A-234	31
Concentric jack shield - - - -	- - -	RA-62A-234	35
Installation hardware - - - -	- - -	BuShips 9-S-3980-L	- - -

7/8-INCH O. D. COAXIAL LINES (70-OHM, GAS-FILLED)

Item	Navy type	Navy drawing	Part No.
Installation instruction - - -	- - -	RA-62A-231	- - -
Bending instruction - - - - -	- - -	RA-62A-232	- - -
Pipe-sleeve coupling - - - - -	- - -	RA-62A-231	1
Inner-conductor elbow, 90° - -	- - -	RA-62A-231	2
Inner-conductor elbow, 45° - -	- - -	RA-62A-231	3
Inner-conductor elbow, coupling	- - -	RA-62A-231	4
Gas-vented elbow insulator - -	- - -	RA-62A-231	5
Coaxial line - - - - -	- - -	RA-62A-231	21
Deck or bulkhead sleeve - - -	- - -	RA-62A-231	22

MIL-HDBK-216
4 January 1962

7/8-INCH O. D. COAXIAL LINES (70-OHMS. GAS-FILLED) - Cont'd

Item	Navy type	Navy drawing	Part No.
Shim - - - - -	- - -	RA-62A-231	23
Gland and follower - - - - -	- - -	RA-62A-231	24
Compression nut - - - - -	- - -	RA-62A-231	25
Solder type coupling - - - - -	- - -	RA-62A-231	26
Short solderless coupling - - - - -	- - -	RA-62A-231	27
Solderless coupling - - - - -	- - -	RA-62A-231	28
Gas servicing coupling - - - - -	- - -	RA-62A-231	29
Anchor joint - - - - -	- - -	RA-62A-231	30
Differential joint - - - - -	- - -	RA-62A-231	31
Expansion coupling - - - - -	- - -	RA-62A-231	32
End seal - - - - -	- - -	RA-62A-231	33
Prefabricated elbow, 90° - - - - -	- - -	RA-62A-231	2,4,5, 21,36
Prefabricated elbow, 45° - - - - -	- - -	RA-62A-231	3,4,5, 21,37
Step hanger - - - - -	- - -	RA-62A-231	38
Bar hanger - - - - -	- - -	RA-62A-231	39
Hanger screws, etc - - - - -	- - -	RA-62A-231	40
Strap screws, etc - - - - -	- - -	RA-62A-231	41
Strap hanger - - - - -	- - -	RA-62A-231	42
Strap liner - - - - -	- - -	RA-62A-231	43
Solderless I.C. connector - - - - -	- - -	RA-62AA-249	- - -
Gas barrier and terminal section	- - -	RA-62F-252	- - -
Test report, line and fittings -	- - -	NRL No. R-1824	- - -

1-5/8-INCH O. D. COAXIAL LINES (50-OHMS, GAS-FILLED)

Item	Navy type	Navy drawing	Part No.
Gas barrier and terminal section	- - -	RA-62F-250	- - -
Tee connection - - - - -	- - -	RA-62F-251	- - -

MISCELLANEOUS ACCESSORIES FOR GAS-FILLED COAXIAL LINES

Item	Navy type	Navy drawing	Part No.
Gas-admission valve - - - - -	- - -	RA-62A-234	32
Automatic bleeder valve - - - - -	10050	RA-62F-229	- - -
Bleeder valve - - - - -	- - -	- - -	- - -
Manual bleeder valve - - - - -	- - -	- - -	- - -
Portable pressure gage - - - - -	- - -	RA-13A-249	- - -
Moisture indicator element - - - - -	62022	RA-62F-230	- - -
Line-testing ohmmeter - - - - -	60010	RA-10F-231	- - -
Line-gassing equipment - - - - -	- - -	RA-62F-222	- - -
Line blowing equipment - - - - -	- - -	RA-62F-221	- - -
Air drier and reactivator, Ship's air supply	- - -	RA-62F-233	- - -
Compressor-dehydrator, single cell	- - -	- - -	- - -
Compressor-dehydrator, dual cell, manual control	- - -	- - -	- - -
Automatic compressor-dehydrator, dual cell	10137	- - -	- - -

MISCELLANEOUS ACCESSORIES FOR SOLID-DIELECTRIC COAXIAL CABLES

Item	Navy type	Navy drawing	Part No.
End seal, RG-8/U, 12/U, 63/U, etc.	62111	RA-62F-300	- - -
End seal, ditto, weather - - - - -	62119	RA-62F-300	- - -
Concentric jack termination - - - - -	62112	RA-62F-300	- - -
Patch cord junction - - - - -	62113	RA-62F-300	- - -
Splice for RG-10/U, 12/U - - - - -	62114	RA-62F-300	- - -
Stuffing-tube packings - - - - -	- - -	RA-62AA-314	- - -
90° shield for 49194 and UG-58/U	- - -	RA-49F-247	- - -
Demountable panel receptacle UG-231/U (fits plugs UG-12/U and UG-21/U)	- - -	RA-49F-246	- - -
Junction-box coupling for RG-8/U	- - -	RA-62F-363	- - -
Splicing kit (injection molding)	MX-904/U	RE-49F-515	- - -

MIL-HDBK-216
4 January 1962

CONCENTRIC PATCH CORDS AND RELATED FITTINGS

Item	Navy type	Navy drawing	Part No.
70-ohm patch cord, 18-inch - - -	49122-B	RA-62F-218	- - -
70-ohm patch cord, 38-inch - - -	49123-B	RA-62F-218	- - -
70-ohm patch cord, 48-inch - - -	49150-B	RA-62F-218	- - -
175-ohm patch cord, 36-inch - -	49124-B	RA-62F-218	- - -
Concentric jack - - - - -	49120	RE-49F-437	- - -
Concentric plug - - - - -	49121-A	RA-49F-216	- - -
Patch cord adapter - - - - -	- - -	RA-49AA-218	- - -
90° plug adapter - - - - -	49151	RA-49F-224	- - -
Binding post adapter - - - - -	49152	RA-49AA-225	- - -
Dummy plug - - - - -	MX-1206/U	RE-49A-600	- - -

WIRE ANTENNA CLAMPS

Item	Navy type	Navy drawing	For wire size
Clamp	10656A	RE-10F-537	7-strand, No. 18 bronze wire
Clamp	10657A	RE-10F-537	5/16-inch wire rope
Clamp	10658A	RE-10F-537	7-strand, No. 18 bronze wire
Clamp	10659A	RE-10F-537	5/16-inch wire rope
Turnbuckle	10660A	RE-10F-537	- - -
Turnbuckle	10661A	RE-10F-537	- - -

INSTRUCTIONS AND Drawings

Item	Drawing No.
Installation instructions, 7/8-inch O.D. gas-filled lines - - - - -	RA-62A-231
Bending instruction, 7/8-inch O.D. gas-filled lines - - - - -	RA-62A-232
Test report, 7/8-inch O.D. gas-filled lines and fittings - - - - -	NRL-R-1824
Installation instruction, 1/4-inch O.D. gas-filled lines - - - - -	RA-62A-234
Installation instructions, RG-11/U and RG-12/U cables - - - - -	RA-62A-303
Instructions for measuring the hardness and creep of insulating cores in solid-dielectric coaxial cables	RA-62A-308

MIL-HDBK-216
4 January 1962

HULL FILLINGS

Type	Description	For use with	Engineering Data
UG-640D/U	Hull Jack	RG-17,177,217/U	Replaces UG-640/U, 640A/U, 640B/U, 640C/U, Series LC termination use MX-2326/U when possible.
UG-665E/U	Hull Jack	RG-14, 217/U	Replaces UG-665/U, 665A/U, 665B/U, 665C/U, 665D/U. Mates type N plug.
UG-666/U	Adapter	RG-14, 81/U	General Use
UG-667/U	Hull Jack	RG-17/U	Replaces by UG-640C/U
UG-668/U	Hull Jack	RG-57, 130/U	Replaced by MX-2646/U
UG-669/U	Hull Jack	RG-14/U	Replaced by UG-665E/U
UG-670/U	Adapter	RG-17, 81/U	General use
UG-671/U	Adapter	RG-14, 81/U	General use
UG-672B/U	Hull Jack	RG-57, 130/U	Replaced by MX-2646/U
UG-975/U	Adapter	RG-17, 82/U	General use
UG-980B/U	Hull Jack	RG-14/U	Replaces UG-980/U, 980A/U. Mates HN plug. Series HN termination
UG-983A/U	Bulkhead Jack	RG-8, 9, 10, 213,214,215/U	Bulkhead use. Mates HN Plug. Replaces UG-983/U
UG-986C/U	Hull Jack	RG-17/U	Replaces UG-986/U, 986A/U, 986B/U
UG-988D/U	Hull Jack	RG-17,177,218/U	Replaces UG-988/U, 988A/U, 988B/U, 988C/U. Mates QDL Plug
UG-1083A/U	Hull Jack	RG-160/U	Replaces UG-1083/U. For use with AT-317/BRR use MX-2646/U and RG-57/U
UG-1101/U	Bulkhead Jack	RG-14,217,219/U	Bulkhead use mates N plug
UG-1130/U	Plug	RG-160/U	Plug-Mates with UG-1083A/U
UG-1147B/U	Stuffing tube	RG-17,177,218/U	Replaced by MX-2326/U
UG-1192/U	Connector	RG-182/U	Never released
UG-1243/U	Stuffing tube	RG-14/U	Replaced by MX-2327/U
UG-1244/U	Adapter	UG-640/U	Adapter-converts UG-640/U to UG-1147B/U
UG-1363/U	Plug	RG-57/U	Plug for base of AT-317/BRR
MX-1203F/U	End Seal	RG-17, 218/U	Replaces MX-1203, 1203A/U thru 1203E/U
MX-1397A/U	End Seal	RG-14	Replaces MX-1397/U
MX-2306/U	Stuffing tube	RG-17,177,218/U	Same as UG-1147A/U. Except for nomenclature change.
MX-2326/U	Stuffing tube	RG-17, 218/U	Stuffing Tube, Hull
MX-2327/U	Stuffing tube	RG-14, 217/U	Stuffing Tube, Hull

MIL-HDBK-216
4 January 1962

HULL FILLINGS - Cont'd

Type	Description	For use with	Engineering Data
MX-2632/U	End Seal	RG-14, 217/U	Replaces MX-1397/U
MX-2646/U	Stuffing tube	RG-57/U	Stuffing Tube, Hull
258-8143	Contact End	UG-988D/U	Contact End for UG-988/U
295-6291	Contact End	UG-665E/U	Contact End for UG-665E/U
336-0440	Contact End	UG-640D/U	Contact End for UG-640D/U
660-6764	Contact End	UG-1083A/U	Contact End for UG-1083A/U
683-1518	Terminal	MX-1203F/U	Terminal for MX-1203F/U

MIL-HDEK-216
4 January 1962

SECTION 17

LIST OF DRAWINGS AND STANDARDS

This section contains a list of drawings and standards covering various R.F. component and waveguide assemblies and is revised periodically to reflect drawing and standard changes. Revisions of drawings and standards are indicated by suffix letters in the drawing or standard numbers. While this section lists current issues of the drawings or standards as of the date of preparation of this handbook, users are urged to check with the issuing activity for the latest issue.

Requests for drawings or standards, required by manufacturers in connection with a Government contract or order should be addressed to the contracting officer of the bureau or agency concerned. Activities of the Armed Services should make application to their respective organizations. Both the title and identifying number should be specified when requesting copies.

AIR FORCE DRAWINGS	-----	17.2
ASESA DRAWINGS	-----	17.3
BUSHIPS DRAWINGS	-----	17.4
SIGNAL CORPS DRAWINGS	-----	17.14
MILITARY STANDARDS	-----	17.16

MIL-HDBK-216
4 January 1962

AIR FORCE DRAWINGS

DRAWING NUMBER	SERVICE TYPE	DRAWING NUMBER	SERVICE TYPE
49B12678A	UG-488/U	52C12837	UG-916/U
49B14151	UG-516/U	52B13050	UG-61B/U
49B14145	UG-497/U	52B13089	UG-921/U
50C12862A	DA-35/U	52D54722	Waveguide Cover, Flanges
50C12863A	UG-514/U	53B54504	CN-29, 42 & 43/UP
50B13081	UG-555/U	53B13632	UG-297A/U
50B13336	UG-574A/U	54B54901	UG-446A/U
50B13388A	UG-594A/U	55C54460	UG-402A/U
50C13669	UG-559/U		
50B14129	UG-594/U		
50D54265	CG-637 & 639/U		
50D54284	UG-579/U		
50D54285	UG-580/U		
50C55057	UG-552/U		
50D55166	DA-18/U		
50D55187	DA-21/U		
50C55195	DA-22/U		
51B12903	UG-516A/U		
51B13712	UG-680/U		
51D13740B	UG-88B, 89A, 253A, 260A, 261A, 262A & 291A/U		
51B14092	RG-133/U		
51B14143	UG-60B/U		
51B14148	UG-59B/U		
51C14157	Assembly Instruc- tions for UG-59B, 60B & 61B/U with cables		

MIL-HDEK-216
4 January 1962

ASESA DRAWINGS

DRAWING NUMBER	SERVICE TYPE	DRAWING NUMBER	SERVICE TYPE
AS-2022C	UG-397/U	AS-2053C	UG-449/U
AS-2023B	UG-398/U	AS-2054C	UG-456, 650/U
AS-2024B	UG-521/U	AS-2055	UG-463/U
AS-2025C	UG-401/U	AS-2056B	UG-466/U
AS-2026B	UG-520/U	AS-2057B	UG-565/U
AS-2027B	UG-445/U	AS-2058C	UG-453, 649/U
AS-2028	UG-403/U	AS-2059	UG-452/U
AS-2029B	UG-523/U	AS-2060	UG-448, 648/U
AS-2030C	UG-405/U	AS-2061B	UG-469/U
AS-2031	UG-446/U	AS-2062B	UG-473/U
AS-2032C	UG-399/U	AS-2063D	UG-467/U
AS-2033B	UG-404/U	AS-2064	UG-455, 659/U
AS-2034	UG-519/U	AS-2065	UG-468/U
AS-2035	UG-522/U	AS-2066	UG-454, 658/U
AS-2037B	UG-518/U	AS-2067C	UG-462/U
AS-2038	UG-400/U	AS-2068B	UG-471/U
AS-2039C	UG-460/U	AS-2069C	UG-457, 660/U
AS-2040B	UG-474/U	AS-2070	UG-472/U
AS-2041	UG-451/U	AS-2072B	Drilling jigs for Waveguide flanges UG-381, 383, 385, and 387/U
AS-2042	UG-458/U		
AS-2043	UG-465/U		
AS-2044	UG-450/U	AS-2073C	UG-461/U
AS-2045	UG-459/U	AS-2074C	UG-470/U
AS-2051B	UG-567/U	AS-2075B	CU-224/U
		AS-2108D	UG-624/U

MIL-HDBK-216
4 January 1962

BUSHIPS DRAWINGS

DRAWING NUMBER	SERVICE TYPE	DRAWING NUMBER	SERVICE TYPE
RE24F167A	AS-44A/APR	RE49F258D	UG-29B/U
RE49F168E	NT49192	RE49F263A	Tests for type N spring contacts
RE49F169E	NT49191	RE49F269A	Assembly instruc- tions for UG-32 & 33/U
RE49F172C	NT49199	RE49F274C	NT49577
RE49F176E	NT49197	RE49F276A	NT49495
RE49F177C	NT49227	RE49F281F	UG-116 & 117/U
RE24D178D	SA-291/U	RE49F289C	UG-109A/U
RE49F187G	UG-32, 33 & 272/U	RE49F290F	UG-98A/U
RE49F189B	UG-275/U	RE49F291L	UG-97A/U
RE49F194C	UG-31/U	RE49F293F	UG-161/U
RE49Z199A	Assembly instruc- tions for NT49197	RE49Z296A	Assembly instruc- tions for NT49577
RE49F209G	UG-43, & 44/U	RE49F334F	UG-214, 200, 438 & 439/U.
RE49F211F	UG-47, & 48/U	RE49F338F	UG-162/U
RE49F217B	UG-71/U	RE49F351B	UG-223/U
RE49F227G	NT49531 & 49532	RE49F356B	UG-207, 256 & 257/U
RE49F228A	UG-73/U	RE49F362B	Assembly instruc- tions for UG-161/U
RE49F235B	Stuffing tube for RG-18 & 17/U cables	RE49F364D	UG-233, 234 & 237/U
RE49F236D	UG-192/U	RE49F365C	UG-249, 250 & 251/U
RE49F241C	NT49543A	RE49F373A	UG-241/U
RE49F242C	NT49544	RE49F374B	UG-242/U
RE49F243D	UG-85/U	RE49F375A	UG-243/U
RE49D244F	UG-87/U	RE49F376B	UG-244/U
RE49D246W	UG-88, 89 & 291/U	RE49F378G	UG-255/U
RE49F245C	UG-86/U	RE49F379C	UG-258/U
RE49F251C	UG-171/U	RE49F385A	UG-226/U
RE49F255C	NT49553		
RE49F256C	UG-114 & 115/U		
RE49F257B	Assembly instruc- tions for UG-192/U		

MIL-HDBK-216
4 January 1962

BUSHIPS DRAWINGS - Cont'd

DRAWING NUMBER	SERVICE TYPE	DRAWING NUMBER	SERVICE TYPE
RE49F389G	UG-273/U	RE49F481A	UG-288 & 289/U
RE49F393C	UG-267 & 268/U	RE49F484A	UG-367/U
RE49F402S	Plugs and Jacks, Type N series	RE49F486C	CN-79, 80, 81 & 89/U
RE49F405F	UG-202/U	RE49F494B	CG-495 & 496/U
RE49F413C	UG-152 & 153/U	RE49F495C	Waveguide assem- blies for use with RG-51/U
RE49F415A	Assembly instruc- tions for UG-180A, 181A & 182A/U	RE49F500C	UG-421/U
RE49AA416B	UG-307/U	RE49F504A	DA-12/U
RE49F418F	UG-253B/U	RE49F510C	MX-367/U
RE49F436A	UG-316/U	RE49F511E	UG-266, MX-539, & 543/U
RE49F437A	NT49120	RE49A513D	RG-109 & 110/U
RE49F442B	UG-318/U	RE49F514B	UG-342/U
RE49A444C	Method of ground- ing cables	RE49F515G	Splicing kits for RF cable
RE49F448B	UG-245/U	RE49A519A	UG-143/U
RE49F449D	UG-340/U	RE49A521A	UG-144/AP
RE49AA450A	UG-224/U	RE49F522E	UG-478/U
RE49J462	UG-69A/U	RE49F523F	UG-479/U
RE49J463B	UG-70A/U	RE49F524F	UG-480/U
RE49F464E	UG-322, 323 & 395/U	RE49F525F	UG-481/U
RE49F466A	UG-328/U	RE49F526E	UG-482/U
RE49F467A	UG-329/U	RE49F531C	TL-586 & 587/U
RE49F468A	UG-330/U	RE49F537D	UG-501/U
RE49F469A	UG-331/U	RE49F538C	UG-502/U
RE49F471A	UG-203/U	RE49F539C	UG-503/U
RE49F472A	UG-346/U	RE49F540B	UG-504/U
RE49F476A	UG-142/U	RE49F550A	UG-206/U
RE49F477B	CG-462/U	RE49F551A	UG-134/U

MIL-HDBK-216
4 January 1962

BUSHIPS DRAWINGS - Cont'd

DRAWING NUMBER	SERVICE TYPE	DRAWING NUMBER	SERVICE NUMBER
RE49F552A	UG-508/U	RE49D608B	UG-678/U
RE49F554G	UG-509 & 510/U	RE49D609B	UG-679/U
RE49F555E	UG-511 & 512/U	RE49D611G	UG-670/U
RE49F560B	UG-530/U	RE49D612A	UG-666/U
RE49F561A	UG-531/U	RE49B615A	WT49212
RE49F565A	UG-332/U	RE49D616B	Assembly instructions for UG-655/U
RE49F568B	UG-535/U		
RE49F571A	UG-284/U	RE49D617C	Assembly instructions for UG-640/U
RE49F573B	Assembly instructions for UG-478/U		
RE49F574B	Assembly instructions for UG-479/U	RE49D618B	Assembly instructions for UG-670/U
RE49F575B	Assembly instructions for UG-480/U	RE49B620B	Gasket, MX- ()/U
RE49F576B	Assembly instructions for UG-481/U	RE49D622E	CG-/U
RE49F577B	Assembly instructions for UG-482/U	RE49D623A	CN-161/U
RE49F581E	Assembly instructions for UG-531/U	RE49C625A	UG-368/U
RE49F586A	MX-1066/U	RE49C626A	UG-369/U
RE49F587A	MX-1067/U	RE49D628C	CN-183/U
RE49F588A	UG-164/U	RE49D630A	UG-920/U
RE49F594D	MX-1113/U	RE49B651D	RG-160A/U
RE49B597A	RE-126/U	RE49C662E	RG-145/U
RE49B598A	RG-127/U	RE49D674D	UG-1004/U
RE49B599B	RG-130 & 131/U	RE49D675A	UG-1005/U
RE49A600A	MX-1206/U	RE49D677A	UG-1018/U
RE49B604B	RG-132/U	RE49D681E	RG-149/U & 150/U
		RE49D683A	Assembly instructions for UG-967, 968, 972/U
		RE49D684A	Assembly instructions for UG-666/U
		RE49D687A	Assembly instructions for UG-505A/U

MIL-HDBK-216
4 January 1962

BUSEIPS DRAWINGS - Cont'd

DRAWING NUMBER	SERVICE TYPE	DRAWING NUMBER	SERVICE NUMBER
RE49D688A	Assembly instructions for UG-926A/U	RE49B737	RG-259/U
RE49D689A	Assembly instructions for MX-1397/U	RE49B738	RG-261/U & 262/U
RE49D692A	CG-1049, 1050 & 1051/U	RE49B739A	RG-266/U
RE49D693A	UG-955/U	RE49B740B	RG-264/U
RE49D694A	Waveguide Assemblies, Bends, 90°	RE49B741	RG-265/U
RE49D695A	Waveguide Assemblies, E-Bends, 45°	RE49B742	RG-267/U
RE49D696B	Waveguide Assembly, UG-958/U	RE49C743D	UG-1320/U
RE49C697A	SA352/U	RE49C744	Bodies for hull fittings
RE49B703C	RG-161/U	RE49C762C	RG-269/U
RE49B709A	RG-71A/U	RE49C763C	RG-270/U
RE49B716C	RG-174/U	RE10B765D	RG-230/U
RE49B717	RG-176/U	RE10A771A	Connectors for Air-dielectric lines General Notes and Requirements
RE49B719	RG-182/U	RE49C774A	RG-284/U
RE49B720D	MX-1901/U	RE49C775A	RG-285/U
RE49B729B	RG-254/U & 255/U	RE49C776A	RG-286/U
RE49B730C	RG-197, 232, 233, 234, 236, 237, 240 & 242/U	RE49C777A	RG-287/U
RE49B731A	RG-244, 245, 246, 247, 248, 249, 250 & 251/U	RE49C778A	RG-288/U
RE49B732B	RG-256/U	RE49C779A	RG-289/U
RE49B733B	RG-257/U & 258/U	RE49C780A	RG-290/U
RE49B734B	RG-252/U & 253/U	RE49C781A	RG-297/U
RE49C735A	Waveguide flange press contact type	RE24I2016A	SA-131/U
RE49B736	UG-1307/U	RE24C2017A	SA-249/U
		RE24C2022A	SA-291/U
		REB49024A	UG-1173/U
		REB49025A	MX-1899/U
		REB49026B	UG-1180/U
		REB49027B	UG-1174/U

MIL-HDBK-216
4 January 1962

BUSHIPS DRAWINGS - Cont'd

DRAWING NUMBER	SERVICE TYPE	DRAWING NUMBER	SERVICE NUMBER
REA49028A	UG-625B/U	REB49061	UG-261B/U
REB49029	MX-1913/U	REB49062A	UG-913A/U
REB49030	MX-1914/U	REB49063A	UG-1094/U
REB49031B	UG-495D/U	REB49064	UG-88C/U
REB49032A	UG-202A/U	REB49065	UG-961A/U
REB49033A	Gas Seal	REB49066	UG-932A/U
REB49035B	UG-1185A/U	REB49067	UG-291B/U
REB49036B	UG-1186A/U	REB49068A	CW-159/U
REB49037B	UG-1187A/U	REB49069	CW-282/U
REB49038	UG-1249/U	REB49070A	UG-914/U
REB49039	UG-1275/U	REB49071C	UG-414A/U
REB49042	UG-146A/U	REB49072	UG-491A/U
REB49044	Rotary joint, special	REB49073	UG-290A/U
REB49046A	MX-564A/U	REB49077A	UG-28A/U
REB49047B	MX-1441/U	REB49079A	UG-58A/U
REB49048A	MX-1462/U	REB49080	UG-107B/U
REA49049	CW-155A/U	REB49081A	UG-159C/U
REA49050	CW-123A/U	REB49082A	UG-160D/U
REB49051B	UG-1098/U	REB49083A	UG-167D/U
REB49052	UG-274A/U	REB49084A	UG-204C/U
REB49053B	UG-912/U	REB49085	UG-464/U
REB49054B	UG-282A/U	REB49086	UG-483/U
REB49055E	UG-911A/U	REB49087	UG-484/U
REB49056A	UG-254A/U	REB49088	UG-486/U
REB49057	UG-262B/U	REB49089A	UG-487/U
REB49058	UG-909/U	REB49090A	UG-536B/U
REB49059	UG-1016A/U	REB49092A	UG-936B/U
REB49060	UG-910/U	REB49094	UG-941A/U
		REB49095A	UG-982/U

MIL-HDBK-216
4 January 1962

EUSHIPS DRAWINGS - Cont'd

DRAWING NUMBER	SERVICE TYPE	DRAWING NUMBER	SERVICE NUMBER
HEB49096	UG-1006/U	HEB49126D	UG-977C/U
HEB49097A	UG-253B/U	HEB49127A	UG-989A/U
HEB49098B	UG-492D/U	HEB49128	UG-1010/U
HEB49099	MX-1142/U	HEB49129	UG-1013A/U
HEB49101	MX-1144/U	HEB49130B	UG-1020A/U
HEB49102B	UG-349B/U	HEA49131	MX-913/U
HEB49103B	UG-335A/U	HEB49132	UG-89B/U
HEB49104B	UG-566A/U	HEB49133	UG-260B/U
HEB49105A	UG-567A/U	HEB49134	MX-498A/U
HEB49106	UG-568/U	HEB49135	MX-675/U
HEB49107	UG-569/U	HEB49136	MX-676/U
HEB49108	UG-626A/U	HEC49137K	MX-1203F/U
HEB49109	UG-627A/U	HEB49138B	MX-1397A/U
HEB49110A	UG-628B/U	HEB49139	MX-1461/U
HEB49111	UG-629/U	HEB49140	MX-1465/U
HEB49112	UG-630/U	HEB49141B	MX-1490B/U
HEB49113A	UG-631/U	HEB49142	MX-1530A/U
HEB49114A	UG-632A/U	HEB49143A	MX-1531A/U
HEB49115	UG-633/U	HEB49144	MX-1554A/U
HEB49116	UG-634/U	HEB49145E	UG-640D/U
HEB49117	UG-642A/U	HEB49146L	UG-665E/U
HEB49118	UG-643/U	HEB49147B	UG-672B/U
HEB49119B	UG-934A/U	HEB49148	UG-980A/U
HEB49120A	UG-946/U	HEB49149B	UG-983A/U
HEB49121A	UG-966A/U	HEB49150C	UG-986C/U
HEB49122B	UG-967B/U	HEB49151G	UG-988D/U
HEB49123B	UG-968B/U	HEB49152B	UG-154A/U
HEB49124A	UG-972B/U	HEB49153C	UG-155B/U
HEB49125A	UG-976/U	HEB49154C	UG-156A/U

MLL-HDBK-216
4 January 1962

BUSEIPS DRAWINGS - Cont'd

DRAWING NUMBER	SERVICE TYPE	DRAWING NUMBER	SERVICE NUMBER
REB49155C	UG-157B/U	REB49190	UG-570/U
REB49156E	UG-208B/U	REB49191A	UG-937A/U
REB49157E	UG-287B/U	REB49192	UG-572/U
REB49158H	UG-216B/U	REB49193	UG-944A/U
REB49159B	UG-219B/U	REB49194	UG-573A/U
REB49160A	UG-352B/U	REB49195A	UG-943B/U
REB49161A	UG-532A/U	REB49201	MX-1143/U
REB49162D	UG-533B/U	REB49202	UG-1058/U
REB49163A	UG-534B/U	REB49203	UG-217A/U
REB49164C	UG-586B/U	REB49204B	UG-259A/U
REB49165C	UG-587B/U	REB49205	UG-350/U
REB49166C	UG-1075C/U	REB49206A	UG-264/U
REB49167D	UG-1076C/U	REB49207A	UG-36/U
REB49168B	MX-407B/U	REB49208A	UG-38A/U
REB49169	UG-1057/U	REB49209A	UG-181A/U
REB49170B	UG-1060A/U	REB49211	UG-603A/U
REB49171A	MX-1556/U	REB49212B	UG-593 & 602A/U
REB49172A	MX-554A/U	REB49213A	UG-1095B/U
REB49173A	UG-701/U	REB49214E	UG-1101/U
REB49174B	UG-702A/U	REB49215B	UG-1073A/U
REB49179	UG-707A/U	REB49216B	UG-1074A/U
REB49173A	UG-708A/U	REB49217B	UG-494B/U
REB49181	UG-709A/U	REB49218A	UG-1021/U
REB49183	UG-711A/U	REB49219A	UG-496/U
REB49184	UG-180A/U	REB49220C	UG-926A/U
REB49185	UG-182A/U	REB49221	MX-103/U
REB49186	UG-336A/U	REB49222A	TL-612/U
REB49187	UG-62A/U	REB49223B	UG-427C/U
REB49188A	UG-34/U	REB49224B	UG-60E/U
REB49189B	UG-222B/U	REB49225B	UG-929B/U

MIL-HDBK-216
4 January 1962

BUSHIPS DRAWINGS - Cont'd

DRAWING NUMBER	SERVICE TYPE	DRAWING NUMBER	SERVICE TYPE
REB49226B	UG-925B/U	REB49255	UG-507A/U
REB49227C	UG-59E/U	REB49256	UG-975/U
REB49228B	UG-61E/U	REB49257A	UG-506A/U
REB49229B	UG-930B/U	REB49258D	UG-1083A/U
REB49230B	UG-927B/U	REB49259A	MX-1057A/U
REB49231	UG-413/U	REB49262A	UG-1111/U
REB49232	UG-1102/U	REB49263B	CG-1174/U
REB49233	UG-1103/U	REB49264B	CG-1175/U
REB49234A	UG-333C/U	REB49265B	CG-1176/U
REB49235A	UG-334C/U	REB49266B	CG-1177/U
REB49236	UG-106/U	REB49267	UG-1087/U
REB49237A	UG-635/U	REB49268A	MX-1599/U
REB49238D	UG-636A/U	REB49269	MX-1600/U
REB49239	UG-347A/U	REB49271A	UG-605/U
REB49240	UG-348A/U	REB49272A	UG-1138/U
REB49241A	UG-415A/U	REB49273C	UG-497A/U
REB49242A	UG-416A/U	REB49274A	UG-213A/U
REB49243A	UG-498/U	REB49275B	UG-218A/U
REB49244	UG-499A/U	REB49276C	UG-309/U
REB49245	UG-997A/U	REB49277A	UG-108A/U
REB49246B	UG-981/U	REB49278A	UG-270A/U
REB49247	UG-564/U	REB49279B	UG-271A/U
REB49248	TL-611/U	REB49280	UG-1059/U
REB49249A	UG-557A/U	REB49283A	UG-101B/U
REB49250	UG-565A/U	REB49284	UG-1079/U
REB49251B	NT49195	REB49285A	UG-279B/U
REB49252B	NT49194	REB49286	UG-1080/U
REB49253D	UG-1061A/U	REB49287B	UG-327A/U
REB49254B	UG-212C/U	REB49288	MX-1598/U

MIL-HDBK-216
4 January 1962

BUSHIPS DRAWINGS - Cont'd

DRAWING NUMBER	SERVICE TYPE	DRAWING NUMBER	SERVICE NUMBER
REB49289B	UG-1041A/U	REB49326D	UG-421B/U
REB49297	UG-954/U	REB49327	MX-1884/U
REB49298A	UG-174/U	REA49328	UG-175/U
REB49300	MX- /U	REA49329	UG-176/U
REB49301B	UG-30D/U	REA49330A	UG-45/U
REB49302B	UG-83A/U	REA49331A	UG-46/U
REB49303	UG-1188/U	REA49332	UG-49/U
REB49304A	UG-422/U	REA49333	UG-50/U
REB49305C	UG-1132A/U	REA49334	UG-140/U
REB49306B	UG-1136/U	REA49335	UG-141/U
REB49307A	UG-1134/U	REB49336G	MX-2326/U
REB49308	UG-1135/U	REB49337A	UG-1022/U
REB49309C	UG-1137B/U	REB49338B	UG-100B/U
REB49310	UG-505A/U	REB49339	UG-571/U
REB49311A	MX-1228/U	REB49340B	UG-493A/U
REB49312B	UG-37A/U	REB49341A	UG-423A/U
REB49313B	MX-1684A/U	REB49342	MX-1801A/U
REB49314	UG-677/U	REB49343	MX-1802A/U
REB49315D	UG-965A/U	REB49344C	UG-559B/U
REB49316	UG-1133/U	REB49345	MX-1870/U
REB49317A	UG-288A/U	REB49346B	UG-1110/U
REB49318C	UG-1244/U	REB49347B	UG-1165/U
REB49319	UG-1142/U	REB49348	UG-1276/U
REB49320	Adapter	REB49349	UG-1221/U
REB49321	UG-1144/U	REB49351A	UG-552/U
REB49322	UG-1145/U	REB49352A	NT-49191
REB49323B	UG-1146/U	REB49353	UG-1195/U
REB49324B	UG-201A/U	REB49354A	UG-1130/U
REB49325	MX-1744A/U	REB49355A	UG-1210/U

MIL-HDEK-216
4 January 1962

BUSHIPS DRAWINGS - Cont'd

DRAWING NUMBER	SERVICE TYPE	DRAWING NUMBER	SERVICE NUMBER
REB49357A	UG-1170/U	REB49401A	UG-1319/U
REB49358B	NT-491388A	REA49402 } REA49403 }	{ Subminiature con- nectors for use with cables RG-188/U and RG-196/U
REB49359	UG-425/U		
REB49360	UG-381/U	REB49405	UG-1363/U
REB49361	UG-306/U	REB49406	MX-3103/U
REB49362	MX-2034/UR	REB49408	UG-1019A/U
REB49363	UG-1214/U	REB49409	UG-1370/U
REB49364B	UG-1213/U	REB49410	UG-1168/U
REB49365	UG-1215/U		
REB49366E	MX-2327/U		
REB49376A	UG-1050/U & 1050A/U		
REB49377	UG-1051/U		
REB49378A	UG-556B/U		
REB49390	UG-1278/U		
REB49391B	Terminal		
REB49392B	Adaptor		
REB49393B	Adaptor		
REB49394B	Adaptor		
REB49395C	N-5935, 295 & 6291		
REB49396	MX-2632/U		
REB49397A	MX-2646/U		
REB49399	UG-1279/U		

MIL-HDBK-216
4 January 1962

SIGNAL CORPS DRAWINGS

DRAWING NUMBER	SERVICE TYPE	DRAWING NUMBER	SERVICE TYPE
SC-C-5187E	UG-1110/U	SC-B-33640A	UG-1161/U
SC-D-5940D	UG-102/U	SC-C-33644A	UG-1156/U
SC-D-5941E	UG-103/U	SC-C-33650A	UG-1160/U
SC-D-5943E	UG-104/U	SC-C-33655A	UG-1154/U
SC-D-6234C	PL-274	SC-C-41141C	UG-657/U
SC-D-10097A	PL-275	SC-C-48783A	UG-641/U
SC-DL-10189	Adapter	SC-C-51117B	UG-1150/U
SC-D-10870A	UG-105/U	SC-C-51118A	UG-1149/U
SC-D-11908F	UG-131/U	SC-DL-51745	UG-1153/U
SC-D-11909F	UG-131/U	SC-DL-51748	UG-1151/U
SC-D-12024D	UG-119/U	SC-DL-51760	UG-1152/U
SC-C-12444A	UG-969/U	SC-C-68401	UG-961/U
SC-C-16495H	UG-106/U	SC-DL-68404	UG-1016/U
SC-C-19882A	RG-185 & 186/U	SC-C-72309C	UG-201/U
SC-C-24456B	UG-1179/U	SC-D-72331A	UG-349A/U
SC-C-24612A	UG-215/U	SC-D-77093C	UG-625/U
SC-C-24728A	UG-1179/U	SC-C-77094A	UG-625B/U
SC-C-26753B	UG-1258/U	SC-C-82969B	RG-156, 157 & 158/U
SC-C-32978C	UG-1189/U	SC-C-83125C	UG-931/U
SC-C-32986C	UG-1190/U	SC-C-83132A	UG-932/U
SC-B-33589B	UG-1157/U	SC-C-86185	UG-1104/U
SC-B-33592B	UG-1158/U	SC-C-86341	UG-1017/U
SC-B-33596A	UG-1159/U	SC-D-98508A	UG-1033/U
SC-C-33601A	CG-1374/U	SC-B-105837	UG-1110/U
SC-B-33610A	UG-1163/U	SC-DL-106727B	UG-970/U
SC-C-33614B	UG-1155/U	SC-C-107432A	CW-339/U
SC-D-33621A	UG-1162/U	SC-D-107574	UG-1056/U
SC-B-33628A	UG-1164/U	SC-D-107575	UG-1055/U
SC-D-33633A	CG-1373/U		

MIL HDBK-216
4 January 1962

SIGNAL CORPS DRAWINGS - Cont'd

DRAWING NUMBER	SERVICE TYPE
SC-C-107602A	UG-959A/U
SC-D-135226	CG-1128 & 1129/U
SC-D-135230	CG-1130 & 1131/U
SC-D-135234	CG-1132 & 1133/U
SC-C-135238	CG-1134 & 1135/U
SC-C-135242	CG-1136 & 1137/U
SC-C-135246	CG-1138 & 1139/U
SC-C-135250	CG-1140 & 1141/U
SC-D-135254	CG-1142 & 1143/U
SC-C-135258	CG-1144 & 1145/U
SC-C-135262	CG-1146/U
SC-C-135266	CG-1147/U

MIL-EDBK-216
4 January 1962

MILITARY STANDARDS

DRAWING NUMBER	SERVICE TYPE	DRAWING NUMBER	SERVICE TYPE
MS15506(Navy)	UG-28A/U	MS35113(Sig C)	UG-690/U
MS15507(Navy)	UG-57B/U	MS35114(Sig C)	UG-691/U
MS16072(Ships)	CN-85A/U	MS35115(Sig C)	UG-692/U
MS16073(Ships)	CN-86A/U	MS35116(Sig C)	UG-693/U
MS16074(Ships)	CN-87A/U	MS35117(Sig C)A	UG-694/U
MS16075(Ships)	CN-110B/U	MS35118(Sig C)C	UG-695/U
MS16076(Ships)	CY-121A/U	MS35119(Sig C)A	UG-696/U
MS16077(Ships)	CN-158A/U	MS35120(Sig C)C	UG-697/U
MS16078(Ships)	CN-159A/U	MS35121(Sig C)A	UG-698/U
MS16079(Ships)	CN-160A/U	MS35122(Sig C)	UG-699/U
MS16080(Ships)	CN-168A/U	MS35123(Sig C)A	UG-700/U
MS16081(Ships)	CN-169A/U	MS35124(Sig C)A	UG-923/U
MS16082(Ships)	CN-245/U	MS35125(Sig C)A	Nut, Hex, Special thd.
MS16083(Ships)	CN-246/U	MS35156	Elbow, Waveguide, (90° H-Plane bend)
MS16084(Ships)	CN-248/U	MS35157	Elbow, Waveguide, (45° E-Plane bend)
MS16085(Ships)	CN-249/U	MS35158	Elbow, Waveguide, (60° E-Plane mitered corner)
MS16086(Ships)	CN-265/U	MS35159	Elbow, Waveguide, (45° E-Plane mitered corner)
MS16087(Ships)	CN-326/U	MS35160	Elbow, Waveguide, (45° H-Plane bend)
MS16088(Ships)	CN-327/U	MS35161	Elbow, Waveguide (45° H-Plane mitered corner)
MS16089(Ships)	CN-328/U	MS35162	Elbow, Waveguide (60° H-Plane bend)
MS16090(Ships)	CN-329/U	MS35163	Elbow, Waveguide (60° E-Plane bend)
MS16091(Ships)	CN-330/U	MS35164	Elbow, Waveguide (90° H-Plane mitered corner)
MS16092(Ships)	CN-331/U		
MS16093(Ships)	CN-332/U		
MS16094(Ships)	CN-247/U		
MS24136(USAF)	RG-178/U		
MS24137(USAF)	RG-179/U		
MS24138(USAF)	RG-180/U		
MS27035	UG-625B/U		
MS27036	UG-1174/U		

MILITARY STANDARDS - Cont'd

DRAWING NUMBER	SERVICE TYPE	DRAWING NUMBER	SERVICE TYPE
MS35165	Elbow, Waveguide (90° E-Plane bend)	MS35281(Sig C)A	UG-634/U
MS35166	Elbow, Waveguide (60° H-Plane mitered corner)	MS35282(Sig C)	UG-637/U
MS35167	Elbow, Waveguide (90° Plane mitered corner)	MS35283A	UG-636A/U
MS35168B	UG-880/U	MS35284A	UG-630A/U
MS35169A	UG-89C/U	MS35285(Sig C)	UG-628A/U
MS35170B	UG-260C/U	MS35286A	UG-627B/U
MS35171A	UG-261C/U	MS35287A	UG-642A/U
MS35172A	UG-262C/U	MS35288A	UG-643/U
MS35173B	UG-274B/U	MS35315B	UG-573B/U
MS35174B	UG-290A/U	MS35316A	UG-571A/U
MS35175A	UG-291C/U	MS35317A	UG-570A/U
MS35176C	UG-491B/U	MS35318A	UG-572A/U
MS35177E	UG-492B/U	MS35319	UG-568/U
MS35178C	UG-1098A/U	MS35320A	UG-566A/U
MS35179D	UG-1094A/U	MS35321(Sig C)	UG-564/U
MS35180B	UG-909A/U	MS35322(Sig C)	UG-567A/U
MS35181A	UG-910A/U	MS35323A	UG-569A/U
MS35182C	UG-911A/U	MS35324(Sig C)	UG-565A/U
MS35183A	UG-912/U	MS35325B	MX-1142/U
MS35184A	UG-914/U	MS35326B	MX-1143/U
MS35185A	MX-195A/U	MS35327A	MX-1144/U
MS35186A	CW-123A/U	MS35328A	UG-633A/U
MS35187A	CW-282/U	MS35329(Sig C)	UG-632/U
MS35220	Waveguide Assembly, (Straight, with 90° twist)	MS35330B	UG-629A/U
MS35279B	UG-631A/U	MS35331(Sig C)	UG-635/U
MS35280A	UG-626B/U	MS35367	UG-913A/U
		MS35368	UG-306B/U
		MS90035	Waveguides, Rigid, Rectangular: Standard sizes

MIL-HDBK-216
4 January 1962

MILITARY STANDARDS - Cont'd

DRAWING NUMBER	SERVICE TYPE	DRAWING NUMBER	SERVICE TYPE
MS90044	UG-54A & 585/U	MS90142	SA-275/U
MS90045	UG-53 & 584/U	MS90156A	UG-27C/U
MS90046	UG-148B & 406A/U	MS90159B	UG-30C/U
MS90047	UG-149A & 407/U	MS90214B	UG-709B/U
MS90048	UG-343A & 440A/U	MS90227A	UG-704A/U
MS90049	UG-344 & 441/U	MS90233A	UG-707A/U
MS90050	UG-383, 385 & 387/U	MS90237B	UG-710B/U
MS90051	UG-553 & 554/U	MS90244B	UG-711B/U
MS90052	UG-417A & 418/U	MS90247B	UG-708B/U
MS90053	UG-435A & 437A/U	MS90248	UG-706/U
MS90054	UG-596 & 598/U	MS90253	UG-702/U
MS90055	UG-600/U	MS90261B	UG-703A/U
MS90056	UG-595 & 597/U	MS90266	UG-701/U
MS90057	UG-599/U	MS90273	UG-705/U
MS90058	UG-40A & 136A/U	MS90277C	MX-1286/U
MS90059	UG-39 & 135/U	MS90292A	UG-935B & 940B/U
MS90060	UG-52A & 137A/U	MS90293B	UG-941B/U
MS90061	UG-51 & 138/U	MS90704	CN-84/U
MS90062	UG-541/U	MS90705	CN-176/U
MS90063	UG-419/U	MS91231B	UG-18D/U
MS90064	Gaskets	MS91233B	UG-19D & 20 D/U
MS90065	Gasket	MS91236B	UG-21E/U
MS90066	MX-1106/U	MS91237B	UG-22E & 23E/U
MS90067	MX-1107/U	MS91238A	UG-204C/U
MS90068	MX-1108/U	MS91239B	UG-167E/U
MS90069	MX-1109/U	MS91596A	UG-216/U
MS90070	MX-1110/U	MS91604	UG-154/U
MS90071	MX-1111/U	MS91610	UG-352A/U
MS90072	MX-1223/U	MS91614	UG-155/U
MS90073	MX-1230/U	MS91616	UG-157/U
MS90074	MX-1231/U	MS91617	UG-156/U
MS90075	MX-1232/U	MS91618	UG-287/U
MS90140	SA-273/U	MS91619A	UG-219/U
MS90141	SA-274/U	MS91620A	UG-208/U

MIL-HDEK-216
4 January 1962

SECTION 18

NOMENCLATURE INDEX

SERVICE TYPE	PAGE NUMBER OR DESCRIPTION	DOCUMENTATION ^{1/}	SERVICE TYPE	PAGE NUMBER OR DESCRIPTION	DOCUMENTATION ^{1/}	
CG-97/AP	13.2	COL. MACHINE WORKS	CG-475/U	8.20	RE49F495	
CG-162/U	Replaced by CG-420/U		CG-495/U	8.21	RE49F495	
CG-163/U	Replaced by CG-420/U		CG-496/U	8.21		
CG-164/U	8.2		CG-501/U	8.21		
CG-165A/U	8.2		CG-502/U	8.21		
CG-166/U	8.2		CG-503/U	8.21		
CG-167A/U	8.2		CG-504/U	8.21		
CG-168/U	8.2		CG-517/U	8.21		
CG-169A/U	8.2		CG-518/U	8.21		
CG-170/U	8.2		CG-519/U	8.3		
CG-176/AP	12.3		CG-537A/U	8.3		
CG-179A/U	8.2		CG-538/U	8.3		
CG-333A/U	8.2		CG-539/U	8.3		
CG-334/U	8.2		CG-540/U	8.3		
CG-343/U	8.2		CG-541/U	8.3		
CG-344/U	8.2		CG-542/U	8.3		
CG-345/U	8.20		RAD. LAB.	CG-575/U	8.21	
CG-346/U	8.20		RAD. LAB.	CG-637/U	8.21	AF50D54265
CG-370/U	8.2			CG-639/U	8.21	AF50D54265
CG-374/U	8.2			CG-684/U	8.3	
CG-418/U	8.2		CG-719/U	5.2		
CG-419/U	8.2		CG-720/U	5.2		
CG-420/U	8.2		CG-730/U	8.3		
CG-461/U	8.3		CG-731/U	8.3		
CG-471A/U	8.20	RE49F495	CG-732/U	8.3		
CG-472A/U	8.20	RE49F495	CG-733/U	8.3		
CG-473/U	8.20	RE49F495	CG-734/U	8.3		
CG-474/U	8.20	RE49F495	CG-735/U	8.3		

^{1/}For latest revisions of drawings, see Section 17.

MIL-HDBK-216
4 January 1962

NOMENCLATURE INDEX - Cont'd

SERVICE TYPE	PAGE NUMBER OR DESCRIPTION	DOCUMENTATION ^{1/}	SERVICE TYPE	PAGE NUMBER OR DESCRIPTION	DOCUMENTATION ^{1/}
CG-736/U	8.3		CG-991/U	8.22	MS35220
CG-779/U	8.3		CG-992/U	8.22	MS35220
CG-802/U	8.4		CG-993/U	8.22	MS35220
CG-843/U	8.4		CG-994/U	8.22	MS35220
CG-844/U	8.21		CG-995/U	8.22	MS35220
CG-863/U	8.4		CG-1010/U	8.22	TITEFLEX
CG-919/U	8.4		CG-1049/U	8.22	RE49D692
CG-930/U	8.4		CG-1050/U	8.22	RE49D692
CG-942/U	8.21		CG-1051/U	8.22	RE49D692
CG-945/U	8.4		CG-1093/U	8.4	
CG-946/U	8.21	GE	CG-1117/U	8.22	
CG-947/U	8.4		CG-1118/U	8.22	
CG-962/U	8.21	GE	CG-1119/U	8.22	
CG-970/U	8.21	CWS	CG-1120/U	8.22	
CG-971/U	8.21	CWS	CG-1121/U	8.22	
CG-972/U	8.21	CWS	CG-1122/U	8.22	
CG-973/U	8.21	CWS	CG-1123/U	8.22	
CG-980/U	8.21	MS35220	CG-1124/U	8.22	
CG-981/U	8.21	MS35220	CG-1125/U	8.4	
CG-982/U	8.21	MS35220	CG-1126/U	8.4	
CG-983/U	8.21	MS35220	CG-1128/U	8.22	SC-D-135226
CG-984/U	8.21	MS35220	CG-1129/U	8.22	SC-D-135226
CG-985/U	8.21	MS35220	CG-1130/U	8.22	SC-D-135230
CG-986/U	8.21	MS35220	CG-1131/U	8.23	SC-D-135230
CG-987/U	8.22	MS35220	CG-1132/U	8.23	SC-D-135234
CG-988/U	8.22	MS35220	CG-1133/U	8.23	SC-D-135234
CG-989/U	8.22	MS35220	CG-1134/U	8.23	SC-D-135238
CG-990/U	8.22	MS35220			

^{1/}For latest revisions of drawings, see Section 17.

MIL-HDBK-216
4 January 1962

NOMENCLATURE INDEX - Cont'd

SERVICE TYPE	PAGE NUMBER OR DESCRIPTION	DOCUMENTATION ^{1/}	SERVICE TYPE	PAGE NUMBER OR DESCRIPTION	DOCUMENTATION ^{1/}
CG-1135/U	8.23	SC-C-135238	CG-1351/U	8.5	
CG-1136/U	8.23	SC-C-135242	CG-1352/U	8.5	
CG-1137/U	8.23	SC-C-135242	CG-1353/U	8.5	
CG-1138/U	8.23	SC-C-135246	CG-1373/U	11.2	SC-DL-33632
CG-1139/U	8.23	SC-C-135246	CG-1374/U	11.2	SL-DL-33600
CG-1140/U	8.23	SC-C-135250	CG-1383/U	8.24	
CG-1141/U	8.23	SC-C-135250	CG-1412/U	8.24	
CG-1142/U	8.23	SC-D-135254	CG-1416/U	8.24	
CG-1143/U	8.23	SC-D-135254	CG-1421/U	8.24	
CG-1144/U	8.23	SC-C-135258	CG-1422/U	8.24	
CG-1145/U	8.23	SC-C-135258	CG-1430/U	8.25	
CG-1146/U	8.24	SC-C-135262	CG-1513/U	8.25	
CG-1147/U	8.24	SC-C-135266	CN-29/UP	14.2	AF53C54504
CG-1148/U	8.24		CN-30A/U	14.2	MS16687
CG-1149/U	8.24		CN-31A/U	14.2	MS16688
CG-1150/U	8.24		CN-32A/U	14.2	MS16689
CG-1151/U	8.24		CN-33A/U	14.2	MS16690
CG-1162/U	8.4		CN-34A/U	14.2	WE
CG-1163/U	8.24		CN-35A/U	14.2	MS16691
CG-1165/U	8.4		CN-36A/U	14.2	MS16692
CG-1296/U	8.24		CN-37A/U	14.2	MS16693
CG-1322/U	8.24		CN-38A/U	14.2	MS16694
CG-1329/U	8.24		CN-39A/U	14.2	MS16695
CG-1332/U	8.24		CN-40A/U	14.2	MS16696
CG-1347/U	8.4		CN-41/U	14.2	WE
CG-1348/U	8.4		CN-42A/UP	14.2	AF53C54504
CG-1349/U	8.4		CN-43A/UP	14.2	AF53C54504
CG-1350/U	8.5		CN-57/U	14.3	PIB

^{1/}For latest revisions of drawings, see Section 17.

MLL-HDBK-216
4 January 1962

NOMENCLATURE INDEX - Cont'd

SERVICE TYPE	PAGE NUMBER OR DESCRIPTION	DOCUMENTATION ¹ /	SERVICE TYPE	PAGE NUMBER OR DESCRIPTION	DOCUMENTATION ¹ /
CN-58/U	14.3	PIB	CN-265/U	14.4	MS16086(NAVY)
CN-84A/U	14.3	MS16071(NAVY)	CN-326/U	14.4	MS16087(NAVY)
CN-85A/U	14.3	MS16072(NAVY)	CN-327/U	14.4	MS16088(NAVY)
CN-86A/U	14.3	MS16073(NAVY)	CN-328/U	14.4	MS16089(NAVY)
CN-87A/U	14.3	MS16074(NAVY)	CN-329/U	14.4	MS16090(NAVY)
CN-89/U	14.3	RE49F486	CN-330/U	14.4	MS16091B(NAVY)
CN-110B/U	14.3	MS16075(NAVY)	CN-331/U	14.4	MS16092(NAVY)
CN-111A/U	14.3	USAF57-2051	CN-332/U	14.4	MS16093(NAVY)
CN-120/U	14.3		CN-333/U	14.4	
CN-121A/U	14.3	MS16076(NAVY)	CN-334/U	14.4	
CN-122/U	14.3		CN-335/U	14.4	
CN-123/U	14.3		CN-336/U	14.4	
CN-158A/U	14.3	MS16077(NAVY)	CU-57/AP	12.2	WE
CN-159A/U	14.3	MS16078(NAVY)	CU-60/AP	12.2	WE
CN-160A/U	14.3	MS16079(NAVY)	CU-72/APS-15B	12.2	
CN-168A/U	14.3	MS16080(NAVY)	CU-73/APS-15A	12.2	
CN-169A/U	14.3	MS16081(NAVY)	CU-78/UP	12.2	
CN-173/U	14.3		CU-79/UP	12.2	
CN-174/U	14.3		CU-83/U	12.2	
CN-175/U	14.3		CU-89/UP	12.2	
CN-176/U	14.3		CU-90/UP	12.2	
CN-177/U	14.3		CU-95/UP	12.2	
CN-178/U	14.3		CU-103/APS-32	12.2	
CN-201/U	14.3	GE	CU-104/APS-34	12.2	
CN-245/U	14.4	MS16082(NAVY)	CU-105/APS-31	12.2	
CN-246/U	14.4	MS16083(NAVY)	CU-106A/APS-33	12.2	PHILCO
CN-247/U	14.4	MS16094(NAVY)			
CN-248/U	14.4	MS16084A(NAVY)			
CN-249/U	14.4	MS16085(NAVY)			

¹For latest revisions of drawings, see Section 17.

NOMENCLATURE INDEX - Cont'd

SERVICE TYPE	PAGE NUMBER OR DESCRIPTION	DOCUMENTATION	SERVICE TYPE	PAGE NUMBER OR DESCRIPTION	DOCUMENTATION
CU-115/U	12.2		CU-203/U	12.4	SPERRY
CU-118/UP	12.2		CU-204/U	12.4	SPERRY
CU-122/U	12.2		CU-205/U	12.4	SPERRY
CU-123/U	12.2		CU-206/U	12.4	SPERRY
CU-127/UP	12.2	RAD. LAB.	CU-207/U	12.4	SPERRY
CU-129/APS-19	12.2		CU-208/U	12.4	SPERRY
CU-135/UP	12.2		CU-209/U	12.4	SPERRY
CU-136/UP	12.2		CU-210/U	12.4	SPERRY
CU-137/APS-23	12.2		CU-211/U	12.4	SPERRY
CU-146/UP	12.3		CU-212/U	12.4	SPERRY
CU-147/U	12.3	TERPENING	CU-213/U	12.4	SPERRY
CU-159/U	12.3		CU-214/UP	12.4	
CU-160/UP	12.3		CU-217/U	12.4	
CU-162/U	12.3		CU-222/U	12.4	SPERRY
CU-164/AP	12.3		CU-224/U	12.4	
CU-165/U	12.3		CU-225/U	12.4	AS-2075
CU-175/U	12.3		CU-233/FPS-3	12.4	
CU-177/MPN-18	12.3		CU-236/CPN-18	12.4	
CU-187/U	12.3	SPERRY	CU-243/UP	12.4	
CU-188/U	12.3	SPERRY	CU-245/U	12.4	
CU-189/U	12.3	SPERRY	CU-258/U	12.5	
CU-190/U	12.3	SPERRY	CU-263/U	12.5	
CU-191/U	12.3	SPERRY	CU-267/U	12.5	
CU-198/U	12.3	SPERRY	CU-295/U	12.5	GE
CU-199/U	12.3	SPERRY	CU-312/SPS-15	12.5	
CU-200/U	12.3	SPERRY	CU-316/APS-20B	12.5	GE
CU-201/U	12.4	SPERRY	CU-319/FBS-8	12.5	GE
CU-202/U	12.4	SPERRY	CU-323/APN-81	12.5	

^{1/}For the latest revisions of drawings, see Section 17.

MIL-EDBK-216
4 January 1962

NOMENCLATURE INDEX - Cont'd

SERVICE TYPE	PAGE NUMBER OR DESCRIPTION	DOCUMENTATION ^{1/}	SERVICE TYPE	PAGE NUMBER OR DESCRIPTION	DOCUMENTATION ^{1/}
CU-325/U	12.5		CU-545/APN-1	12.6	
CU-333/URM-60	12.5		CU-549/TPS-1D	12.6	
CU-338/AP	12.5	WESTING.	CU-556/FPS-6A	12.6	
CU-339/AP	12.5	WESTING.	CU-583/FPS-18	12.6	
CU-341/U	12.5		CU-597/FPS-7	12.6	
CU-349/APS-25	12.5		CU-606/GPS	12.7	
CU-354/MPQ-12	12.5		CU-608/U	12.7	
CU-356/SPN-18	12.5		CU-609/U	12.7	
CU-358/U	12.5		CU-610/UR	12.7	
CU-387/FPN-28	12.5		CU-632/U	12.7	
CU-388/FPN-28	12.5		CU-652/UR	12.7	
CU-401/APS-64	12.5		CU-653/UR	12.7	
CU-428/FPN-13	12.6		CU-662/GPQ-TLA	12.7	
CU-430/URN-3	12.6		CU-673/U	12.7	
CU-431/URN-3	12.6		CU-681/GRN-9C	12.7	
CU-446/GPS-4	12.6		CU-682/GRN-9C	12.7	
CU-447/APW-16	12.6		CU-721/TPN-12	12.7	
CU-453/FPS-14	12.6		CU-730/U	12.7	
CU-455/URM-87	12.6		CU-733/APS-80	12.7	
CU-456/U	12.6		CU-735/SPS-5C	12.7	
CU-457/APX	12.6		CU-739/SP	12.7	
CU-479/APQ-39	12.6		CU-742/FPN-34	12.7	
CU-484()/UP	12.6		CU-743/FPN-34	12.7	
CU-485()/UP	12.6		CU-767/FPS-35	12.7	
CU-515/FPS-19	12.6		CU-773/URA-27	12.7	
CU-516/FPS-20	12.6		CU-783/APW-22	12.7	
CU-528/U	12.6		CU-785/GKA-5	12.7	
CU-529/MPS-16	12.6		CU-790/FPS-30	12.7	

^{1/}For latest revisions of drawings, see Section 17.

NOMENCLATURE INDEX - Cont'd

SERVICE TYPE	PAGE NUMBER OR DESCRIPTION	DOCUMENTATION ¹ /	SERVICE TYPE	PAGE NUMBER OR DESCRIPTION	DOCUMENTATION ¹ /
CU-802/GKA-6	12.7		DA-19/U	Replaced by DA-149/U	
CU-817/FRT-49	12.7		DA-20/URM-68	Replaced by DA-148/U	
CU-820/URA-34	12.7		DA-21/U	Replaced by DA-148/U	
CU-823/FPS-61	12.7		DA-22/U	Replaced by DA-146/U	
CU-824/FPS-61	12.7		DA-23/U	Replaced by DA-159/U	
CU-845/FRT-49	12.7		DA-24/U	Replaced by DA-160/U	
CU-848/FPS-6	12.7		DA-25/U	Replaced by DA-158/U	
CU-851/ALQ-23	12.7		DA-26/U	Replaced by DA-160/U	
CU-852/ALQ-23	12.7		DA-27/U	Replaced by DA-159/U	
CU-853/ALQ-23	12.8		DA-28/U	Replaced by DA-158/U	
CU-854/ALQ-23	12.8		DA-45/UP	13.2	PRD
CU-857/UP	12.8		DA-51/U	Replaced by DA-145/U	
CU-861()/U	12.8		DA-53/U	Replaced by DA-147/U	
CW-123A/U	3.30	MS35186	DA-54/U	Replaced by DA-147/U	
CW-155A/U	3.30	HEA49049	DA-55/U	13.2	SPERRY
CW-159/U	3.30	HEB49068	DA-74/U	Replaced by DA-149/U	
CW-282/U	3.30	MS35187	DA-77/U	13.2	PRD
DA-2/UP	Replaced by DA-144/U		DA-81/U	13.2	PRD
DA-3/UP	Replaced by DA-148/U		DA-82/U	13.2	PRD
DA-4/UP	Replaced by DA-149/U		DA-86/U	Replaced by DA-147/U	
DA-6/U	13.2	SUB.SIG.CO.	DA-96/U	Replaced by DA-145/U	
DA-7/UP	13.2	PRD	DA-97/U	Replaced by DA-146/U	
DA-8/UP	13.2	PRD	DA-98/U	Replaced by DA-159/U	
DA-9/UP	13.2	PRD	DA-99/SLT	13.2	BIRD ELECT.
DA-10/UP	13.2	PRD	DA-100/SLT-3	Replaced by DA-145/U	
DA-11/UP	13.2	PRD			
DA-15/URM-63	Replaced by DA-146/U		DA-102/UPM-63	13.2	SPERRY
DA-18/U	Replaced by DA-145/U				

¹For latest revisions of drawings, see Section 17.

MIL-HDBK-216
4 January 1962

NOMENCLATURE INDEX - Cont'd

SERVICE TYPE	PAGE NUMBER OR DESCRIPTION	DOCUMENTATION ^{1/}	SERVICE TYPE	PAGE NUMBER OR DESCRIPTION	DOCUMENTATION ^{1/}
DA-103/U	Replaced by DA-146/U		MX-554A/U	3.30	REB49172
DA-107/URM-84	Replaced by DA-148/U		MX-564A/U	3.36 - 3.47	REB49046
DA-111/UPM-12	13.2	MIL-R-8724	MX-675/U	3.69	REB49135
DA-112/U	Replaced by DA-145/U		MX-676/U	3.69	REB49136
DA-115/U	Replaced by DA-146/U		MX-840/U	3.69	GE
DA-117/U	Replaced by DA-148/U		MX-913/U	3.47	REA49131
DA-120/U	Replaced by DA-145/U		MX-1057/U	3.69	REC49259
DA-141/U	13.2	SPEERRY	MX-1066/U	11.2	RE49F586
DA-142/U	13.2	SPEERRY	MX-1067/U	11.2	RE49F587
DA-143/U	13.2	SPEERRY	MX-1113/U	3.69	MS90069
DA-144/U	13.2		MX-1142/U	3.33	MS35325
DA-145/U	13.2		MX-1143/U	3.33	MS35326
DA-146/U	13.2		MX-1144/U	3.33	MS35327
DA-147/U	13.2		MX-1169/U	3.69	
DA-148/U	13.2		MX-1170/U	3.69	
DA-149/U	13.2		MX-1203F/U	16.5 - 3.69	REB49137
DA-154/U	13.2	RADC-1817	MX-1228/U	3.69	REA49311
DA-158/U	13.2		MX-1286/U	3.33 - 3.47	MS90277
DA-159/U	13.2		MX-1397A/U	16.5 - 3.69	REB49138
DA-160/U	13.2		MX-1441/U	3.47	REB49047
MT-412/U	3.30	RE49F331	MX-1461/U	3.69	REB49139
MX-103/U	3.36	REB49221	MX-1462/U	3.43 - 3.47	REB49048
MX-195A/U	3.27 - 3.30	MS35185	MX-1465/U	3.69	REB49140
MX-367/U	3.30 - 3.27	RE49F510	MX-1490B/U	3.69	REB49141
MX-407B/U	3.69	REB49168	MX-1530A/U	3.69	REB49142
MX-498A/U	Replaced by MX-1465/U		MX-1531A/U	3.69	REB49143
MX-539/U	3.65	RE49F511	MX-1554A/U	3.69	REB49144
MX-543/U	3.65	RE49F511	MX-1556/U	3.62 - 3.65	REB49171

^{1/}For latest revisions of drawings, see Section 17.

18.8

NOMENCLATURE INDEX - Cont'd

SERVICE TYPE	PAGE NUMBER OR DESCRIPTION	DOCUMENTATION ¹	SERVICE TYPE	PAGE NUMBER OR DESCRIPTION	DOCUMENTATION ¹
MX-1564/U	3.69	BAR LOW	MX-2632/U	3.69	
MX-1598/U	3.69	REB49288	RG-4/U	2.14	RE9202
MX-1599/U	3.68	REB49268	RG-5B/U	2.14	
MX-1600/U	3.68	REA49269	RG-6A/U	2.14	
MX-1684/U	3.69	REB49313	RG-7/U	2.14	
MX-1744A/U	3.69	REB49325	RG-8A/U	2.14	
MX-1758/U	3.30		RG-9B/U	2.14	
MX-1759/U	3.30		RG-10A/U	2.14	
MX-1801A/U	3.69	REB49342	RG-11A/U	2.14	
MX-1802A/U	3.69	REB49343	RG-12A/U	2.14	
MX-1870/U	3.33-3.55	REA49345	RG-13A/U	2.14	
MX-1884/U	3.69	REB49327	RG-14A/U	2.14	
MX-1899/U	3.56	REB49205	RG-15/U	2.14	
MX-1901/U	3.69	REA9D720	RG-16/U	2.14	
MX-1913/U	3.56	REA49029	RG-17B/U	2.14	
MX-1914/U	3.56	REA49030	RG-18A/U	2.14	
MX-2306/U	16.5		RG-19A/U	2.14	
MX-2326/U	16.6	REB49366	RG-20A/U	2.15	
MX-2327/U	16.6	REB49336	RG-21A/U	2.15	

¹For latest revisions of drawings, see Section 17.

MIL-HDBK-216
4 January 1962

NOMENCLATURE INDEX - Cont'd

SERVICE TYPE	PAGE NUMBER OR DESCRIPTION	DOCUMENTATION ¹	SERVICE TYPE	PAGE NUMBER OR DESCRIPTION	DOCUMENTATION ¹
RG-22B/U	2.15		RG-40/U	2.16	
RG-23A/U	2.15		RG-41/U	2.16	
RG-24A/U	2.15		RG-42/U	2.16	
RG-25A/U	2.15		RG-43/U	2.16	
RG-26A/U	2.15		RG-44/U	5.5	
RG-27A/U	2.15		RG-45/U	5.5	
RG-28B/U	2.15		RG-46/U	5.5	
RG-29/U	2.15		RG-47/U	5.5	
RG-30/U	2.15		RG-48/U	6.18	MS90035
RG-31/U	2.15		RG-49/U	6.18	MS90035
RG-32/U	2.15		RG-50/U	6.18	MS90035
RG-33/U	2.15		RG-51/U	6.18	MS90035
RG-34B/U	2.15		RG-52/U	6.18	MS90035
RG-35B/U	2.15		RG-53/U	6.18	MS90035
RG-36/U	2.16		RG-54A/U	2.16	
RG-37/U	2.16		RG-55B/U	2.16	
RG-38/U	2.16		RG-56/U	2.16	WE-KS9351
RG-39/U	2.16		RG-57A/U	2.16	
			RG-58C/U	2.16	

¹For latest revisions of drawings see Section 17.

NOMENCLATURE INDEX - Cont'd

SERVICE TYPE	PAGE NUMBER OR DESCRIPTION	DOCUMENTATION ¹	SERVICE TYPE	PAGE NUMBER OR DESCRIPTION	DOCUMENTATION ¹
RG-59B/U	2.16		RG-78A/U	2.17	
RG-60/U	2.16		RG-79B/U	2.17	
RG-61/MRQ	SPECIAL 500 ohm line		RG-80/U	5.2	
RG-62C/U	Reassigned new nomenclature	RG-210/U	RG-81/U	2.17	
RG-63B/U	2.16		RG-82/U	2.17	
RG-64A/U	2.17		RG-83/U	2.17	
RG-65A/U	2.17		RG-84A/U	2.17	
RG-66/U	6.18	MS90035	RG-85A/U	2.17	
RG-67/U	6.18	MS90035	RG-86/U	2.17	
RG-68/U	6.18	MS90035	RG-87A/U	2.17	
RG-69/U	6.18	MS90035	RG-88B/U	2.18	
RG-71B/U	2.17		RG-89/U	2.18	
RG-72/U	2.17		RG-90/U	2.18	
RG-73/U	2.17		RG-91/U	6.18	MS90035
RG-74A/U	2.17		RG-92/U	5.2	
RG-75/U	6.18	MS90035	RG-93/U	2.18	
RG-76/U	5.5		RG-94/U	2.18	
RG-77A/U	2.17				

¹For latest revisions of drawings, see Section 17.

MIL-HDBK-216
4 January 1962

NOMENCLATURE INDEX - Cont'd

SERVICE TYPE	PAGE NUMBER OR DESCRIPTION	DOCUMENTATION ¹	SERVICE TYPE	PAGE NUMBER OR DESCRIPTION	DOCUMENTATION ¹
RG-95/U	6.18	MS90035	RG-117A/U	2.18	
RG-96/U	6.18	MS90035	RG-118A/U	2.18	
RG-97/U	6.18	MS90035	RG-119/U	2.18	
RG-98/U	6.18	MS90035	RG-120/U	2.18	
RG-99/U	6.18	MS90035	RG-121/U	6.18	MS90035
RG-100/U	2.18	FTR	RG-122/U	2.18	SURPENANT
RG-101/U	70-ohm cable		RG-124/U	2.18	BOSTON INS.
RG-102/U	Two conductors, 140 ohm cable		RG-125/U	2.18	FTR
RG-103/U	6.18	MS90035	RG-126/U	2.18	RE49B597
RG-104/U	6.18	MS90035	RG-127/U	6.18	RE49B598
RG-105/U	6.18	MS90035	RG-128/U	5.2	
RG-106/U	6.18	MS90035	RG-129/U	8.4	
RG-107/U	6.18	MS90035	RG-130/U	2.18	RE49B599
RG-108A/U	2.18		RG-131/U	2.18	RE49B599
RG-109/U	6.18	RE49A513	RG-132/U	6.18	RE49B604
RG-110/U	6.18	RE49A513	RG-133A/U	2.18	
RG-111A/U	2.18		RG-134/U	5.2	
RG-112/U	6.18	MS90035	RG-135/U	6.18	MS90035
RG-113/U	6.18	MS90035	RG-136/U	6.18	MS90035
RG-114A/U	2.18		RG-137/U	6.18	MS90035
RG-115A/U	2.18	MIL-C-17/92 (USAF)	RG-138/U	6.18	MS90035
RG-116/U	2.18		RG-139/U	6.18	MS90035
			RG-140/U	2.18	
			RG-141A/U	2.19	

¹For latest revisions of drawings, see Section 17.

MIL-HDBK-216
4 January 1962

NOMENCLATURE INDEX - Cont'd

SERVICE TYPE	PAGE NUMBER OR DESCRIPTION	DOCUMENTATION ¹	SERVICE TYPE	PAGE NUMBER OR DESCRIPTION	DOCUMENTATION ¹
RG-142A/U	2.19		RG-162/U	5.2	
RG-143A/U	2.19		RG-163/U	6.18	
RG-144/U	2.19	AMPHENOL	RG-164/U	2.19	
RG-145/U	Twin conductor RF cable: similar to BTL dwg #CA-1301, except without #19 quads of control wires.		RG-165/U	2.19	
			RG-166/U	2.19	
			RG-167/U	6.18	MS90035
RG-146/U	2.19		RG-168/U	6.18	MS90035
RG-147/U	2.19		RG-169/U	6.18	MS90035
RG-148/U	2.19		RG-170/U	6.18	MS90035
RG-149/U	2.19	RE49B681	RG-171/U	6.18	MS90035
RG-150/U	2.19	RE49B681	RG-172/U	6.18	MS90035
RG-151/U	5.3		RG-173/U	6.18	MS90035
RG-152/U	5.3		RG-174/U	2.19	RE49B716
RG-153/U	5.3				
RG-154/U	5.3		RG-176/U	2.19	RE49B717
RG-155/U	5.3		RG-177/U	2.19	
RG-156/U	2.19	SC-C-82969	RG-178B/U	2.19	
RG-157/U	2.19	SC-C-82969	RG-179B/U	2.19	
RG-158/U	2.19	SC-C-82969	RG-180B/U	2.20	
RG-159/U	2.19	BOSTON INSUL	RG-181/U	2.20	
RG-160A/U	2.19		RG-182/U	2.20	RE49B719
RG-161/U	2.19	RE49B703C	RG-183/U	2.20	
			RG-184/U	2.20	FED. TEL. LABS.

¹For latest revisions of drawings, see Section 17.

MIL-HDBK-216
4 January 1962

NOMENCLATURE INDEX - Cont'd

SERVICE TYPE	PAGE NUMBER OR DESCRIPTION	DOCUMENTATION ^{1/}	SERVICE TYPE	PAGE NUMBER OR DESCRIPTION	DOCUMENTATION ^{1/}
RG-185/U	2.20		RG-213/U	2.21	
RG-186/U	2.20	FED. TEL. LABS.	RG-214/U	2.21	
			RG-215/U	2.21	
RG-187A/U	2.20		RG-216/U	2.21	
			RG-217/U	2.21	
RG-188A/U	2.20		RG-218/U	2.21	
RG-189/U	2.20	PHELPS-DODGE	RG-219/U	2.21	
RG-190/U	2.20		RG-220/U	2.21	
RG-191/U	2.20		RG-221/U	2.21	
RG-192/U	2.20		RG-222/U	2.21	
RG-193/U	2.20		RG-223/U	2.21	
RG-194/U	2.20		RG-224/U	2.21	
			RG-225/U	2.21	
RG-195A/U	2.20		RG-226/U	2.21	
RG-196A/U	2.20		RG-227/U	2.21	
RG-201/U	6.18	MS90035			
RG-202/U	6.18	MS90035	RG-228A/U	2.21	
RG-203/U	6.18	MS90035	RG-229/U	2.21	
RG-204/U	6.18	MS90035	RG-230/U	2.21	
RG-205/U	6.18	MS90035	RG-235/U	2.21	
RG-206/U	6.18	MS90035			
RG-207/U	6.18	MS90035	RG-264A/U	2.21	
RG-208/U	6.18	MS90035	RG-266/U	2.21	
RG-209/U	2.21	MIL-C-17/96 (USAF)	RG-271/U	6.18	MS90035
RG-210/U	2.21	MIL-C-17/97 (USAF)	RG-272/U	6.18	
RG-211/U	2.21		RG-273/U	6.18	
RG-212/U	2.21		RG-274/U	6.18	
			RG-275/U	6.18	

^{1/}For latest revisions of drawings, see Section 17.

MIL-STD-216
4 January 1962

NOMENCLATURE INDEX - Cont'd

SERVICE TYPE	PAGE NUMBER OR DESCRIPTION	DOCUMENTATION ^{1/}	SERVICE TYPE	PAGE NUMBER OR DESCRIPTION	DOCUMENTATION ^{1/}
RG-276/U	6.18		SA-163/U	4.2	GEN. COMMUNICATIONS CO.
RG-277/U	6.18		SA-176/U	4.2	RE24AA2000
RG-278/U	6.18		SA-185/U	4.2	MIL-S-3928/1
RG-279/U	2.21		SA-188/U	4.2	GE
RG-280/U	2.22		SA-189/U	4.2	GE
RG-281/U	2.22		SA-210/U	4.2	BuAER 17R23
RG-282/U	2.22		SA-212/U	4.2	BuAER 17R23
RG-283/U	2.22		SA-215/U	4.2	HAZELTINE ELECT.
RG-290/U	6.18		SA-221/MPN-5	10.2	
RG-291/U	6.18		SA-222/UP	10.2	
RG-293/U	2.22		SA-249/U	4.2	RE24C2017
RG-294/U	2.22		SA-269/U	10.2	GE
RG-295/U	2.22		SA-270/U	10.2	GE
RG-296/U	2.22		SA-273/U	4.2	MIL-S-3928/2
SA-14/SPR-1	4.2	GALVIN MFG. CO.	SA-274/U	4.2	MIL-S-3928/3
SA-23/APR-4	4.2		SA-275/U	4.3	MIL-S-3928/4
SA-44/APR	4.2		SA-280/APX-17	4.3	HAZELTINE ELEC. CORP.
SA-44A/APR	4.2	RE24F167			
SA-56/SPR-1	4.2	CANFIELD MFG. CO.	SA-288/U	4.3	BIRD ELECTRONICS CO.
SA-74/U	4.2	BIRD ELEC. CO.	SA-291/U	4.3	RE24D178
SA-131/U	4.2	RE24D2016	SA-293/U	4.3	RE24F174
SA-139/U	4.2	RE23F225	SA-303/U	4.3	MIL-S-3928/5
SA-140/U	4.2	RE23F174	SA-304/U	4.3	INDUSTRIAL PROD. CO.
SA-141/U	4.2	RE23F225	SA-323/U	4.3	BuAER 52A-3A101
SA-149/U	4.2	DESIGNERS FOR INDUSTRY INC.	SA-324/U	4.3	BuAER 52A-3A102
SA-150/U	4.2	do	SA-325/U	4.3	BuAER 52A-3A103
SA-151/U	4.2	do	SA-326/U	4.3	BuAER 52A-3A104
SA-152/U	4.2	do			
SA-153/U	4.2	do			

^{1/}For latest revisions of drawings, see Section 17.

MIL-HDBK-216
4 January 1962

NOMENCLATURE INDEX - Cont'd

SERVICE TYPE	PAGE NUMBER OR DESCRIPTION	DOCUMENTATION ¹ /	SERVICE TYPE	PAGE NUMBER OR DESCRIPTION	DOCUMENTATION ¹ /
SA-327/U	4.3	BuAER 52A-3A105	SA-511/U	10.2	BOGART
SA-328/U	4.3	BuAER 52A-3A106	SA-512/U	10.2	BOGART
SA-329/U	4.3	BuAER 52A-3A107	SA-516/U	10.2	BOGART
SA-330/U	4.3	THOMPSON PRODUCTS CO.	SA-518/APS-62	10.2	LAVOIE
SA-335/U	4.3	ANDREW CORP.	SA-520/U	4.3	STANFORD RESEARCH INSTIT.
SA-336A/U	4.3	JOWIL ELEC. INC.	SA-521/U	4.3	STANFORD RESEARCH INSTIT.
SA-340/U	10.2	RCA	SA-527/APX	10.2	SPEERY GYROSCOPE CO.
SA-346/GRD	4.3	MIL-R-10637 (SIG C)	SA-540/UP	10.2	RADC-1701
SA-352/U	4.3	RE49C697	SA-541/UP	10.2	RADC-1701
SA-361/U	10.2	WEBSTER CHICAGO CORP.	SA-543/GPX	4.3	BELL TEL.LAB.
SA-364/U	10.2	AIRTRON, INC.	SA-560/FPS-33	10.3	GE
SA-374/U	10.2		SA-563/U	10.3	
SA-380/U	10.2		SA-570/GRT-5	4.4	COLLINS RADIO CO.
SA-381/U	10.2	AIRTRON, INC.	SA-572/FRT-41	4.4	
SA-431/U	4.3	THOMPSON PROD. CO	SA-602/U	4.4	BOGART MFG.CO.
SA-436/FPS-14	10.2	AIRTRON, INC.	SA-605/U	10.3	BOGART
SA-437/BPS-3	10.2	WESTERN ELEC.CO.	SA-610/TPN-12	10.3	AIRTRON, INC.
SA-445/U	4.3		SA-641/U	10.3	AIRTRON, INC.
SA-448/FPS-20	10.2	RADC-2476	SA-642/U	10.3	AIRTRON, INC.
SA-477/FPS-19	4.3	AIRBORNE INSTRUMENT LAB. INC.	SA-643/U	10.3	
SA-478/URT	4.3	THOMPSON PROD. CO	SA-667/U	10.3	RAYTHEON MFG.CO.
SA-489/U	10.2	BOGART	SA-698/FPS-26	10.3	MIL-R-9691A (USAF)
SA-490/U	10.2	BOGART	SA-699/FPS-26	10.3	MIL-R-9691A (USAF)
SA-509/U	10.2	BOGART	SA-702/U	4.4	BOGART MFG.CO.
SA-510/U	10.2	BOGART	SA-709/FPS-26	10.3	MIL-C-9692A (USAF)

¹For latest revisions of drawings, see Section 17.

MIL-HDBK-216
4 January 1962

NOMENCLATURE INDEX - Cont'd

SERVICE TYPE	PAGE NUMBER OR DESCRIPTION	DOCUMENTATION ^{1/}	SERVICE TYPE	PAGE NUMBER OR DESCRIPTION	DOCUMENTATION ^{1/}
SA-741/ALD-3	4.4	DANBURY KNUDSEN	UG-22E/U	3.44	MS91237
TL-323/U	3.40	RE49F386	UG-23E/U	3.44	MS91237
TL-324/U	3.40	RE49F386	UG-24/U	Replaced by UG-21D/U	
TL-325/U	3.40	RE49F387	UG-25/U	Replaced by UG-22D/U	
TL-326/U	3.40	RE49F387	UG-26/U	Replaced by UG-23D/U	
TL-611/U	3.68	REA49268	UG-27C/U	3.44	MS90156
TL-612/U	3.36	REB49222	UG-28A/U	3.44	MS15506
TS-74A/UPM	13.2		UG-29B/U	3.44	RE49F258
TS-105/TPM-1	13.2		UG-30D/U	3.44	REB49301
TS-108A/UP	Replaced by DA-146/U		UG-31/U	3.26	RE49F194
TS-231A/AP	Replaced by DA-148/U		UG-32/U	3.24	RE49F187
TS-253/AP	Replaced by DA-160/U		UG-33/U	3.24	RE49F187
TS-332/UP	Replaced by DA-146/U		UG-34/U	3.50	REB49188
TS-335/MPM	Replaced by DA-145/U		UG-35/U	Replaced by UG-350/U	
TS-338/UP	Replaced by DA-145/U		UG-36/U	3.50	REB49207
UG-9/U	Replaced by UG-18C/U		UG-37A/U	3.50	REB49312
UG-10/U	Replaced by UG-19C/U		UG-38A/U	3.50	REB49208
UG-11/U	Replaced by UG-20C/U		UG-39/U	7.5	MS90059
UG-12/U	Replaced by UG-21D/U		UG-40B/U	7.5	MS90058
UG-13/U	Replaced by UG-22D/U		UG-41/U	Cancelled	
UG-14/U	Replaced by UG-23D/U		UG-42/U	5.3	RE49F198
UG-15/U	Replaced by UG-18C/U		UG-43/U	11.2	RE49F209
UG-16/U	Replaced by UG-19C/U		UG-44/U	11.2	RE49F209
UG-17/U	Replaced by UG-20C/U		UG-45/U	11.2	REA49330
UG-18D/U	3.44	MS91231	UG-46/U	11.2	REA49331
UG-19D/U	3.44	MS91233	UG-47/U	11.2	RE49F211
UG-20D/U	3.44	MS91233	UG-48/U	11.2	RE49F211
UG-21E/U	3.44	MS91236	UG-49/U	11.2	REA49332

^{1/}For latest revisions of drawings, see Section 17.

MIL-HDBK-216
4 January 1962

NOMENCLATURE INDEX - Cont'd

SERVICE TYPE	PAGE NUMBER OR DESCRIPTION	DOCUMENTATION ^{1/}	SERVICE TYPE	PAGE NUMBER OR DESCRIPTION	DOCUMENTATION ^{1/}
UG-50/U	11.2	REA49333	UG-75/U	Adapter, RG-17/U to 1-5/8 inch rigid line	
UG-51/U	7.5	MS90061			
UG-52B/U	7.5	MS90060	UG-76/TSM	Special Adapter	
UG-53/U	7.5	MS90045	UG-77/TSM	Special Adapter	
UG-54B/U	7.5	MS90044	UG-78/AP	Special Adapter	BTL
UG-55/U	7.5	RE492205	UG-79/U	Adapter, type N plug to RG-52/U waveguide	
UG-56/U	7.5	RE492205			
UG-57B/U	3.44	MS15507 (NAVY)	UG-80/U	Adapter, RG-51/U to RG-52/U waveguide	
UG-58A/U	3.44	REB49079	UG-81/U	Adapter, type N plug to RG-52/U waveguide	
UG-59E/U	3.35	REB49227			
UG-60E/U	3.35	REB49224	UG-82/U	1-5/8 inch coaxial line coupling (M)	GE
UG-61E/U	3.35	REB49228			
UG-62A/U	3.50	REB49187	UG-83B/U	3.19	REB49302
UG-63/U	Replaced by UG-38A/U		UG-84/GR	Special Adapter	
UG-64/APR	Adapter, Special Assembly		UG-85/U	3.27	RE49F243
			UG-86/U	3.27	RE49F245
UG-65/U	7.5	RE49F213	UG-87/U	3.27	RE49D244
UG-66/U	7.5	RE49F213	UG-88E/U	3.28	MS35168
UG-67/U	8.8	RE492219	UG-89C/U	3.28	MS35169
UG-68/U	8.8	RE492220	UG-90/U	Replaced by UG-291B/U	
UG-69A/U	8.8	RE49J462	UG-91A/U	3.48	RE49F402
UG-70A/U	8.8	RE49J463	UG-92A/U	3.48	RE49F402
UG-71/U	Replaced by UG-192/U	RE49F217	UG-93A/U	3.48	RE49F402
UG-72/GR	Special Adapter		UG-94A/U	3.48	RE49F402
UG-73/U	3.64	RE49F228	UG-95A/U	3.48	RE49F402
UG-74/U	Adapter, RG-17/U to 1-5/8 inch rigid line		UG-96A/U	3.48	RE49F402
			UG-97B/U	3.43	RE49F291

^{1/}For latest revisions of drawings, see Section 17.

MIL-HDE K-216
4 January 1962

NOMENCLATURE INDEX - Cont'd

SERVICE TYPE	PAGE NUMBER OR DESCRIPTION	DOCUMENTATION ^{1/}	SERVICE TYPE	PAGE NUMBER OR DESCRIPTION	DOCUMENTATION ^{1/}
UG-98A/U	3.43	RE49F290	UG-125/U	Adapter, type AN-3100-14S-4P to British 104-701	SPECIAL
UG-99/PPN/2	Special Adapter				
UG-100B/U	3.43	REB49338	UG-126/U	Adapter, type (GE) F-27J764 to AN-3108-22-148	SPECIAL
UG-101B/U	3.43	REB49283			
UG-102/U	3.62	SC-D-5940	UG-127/U	Adapter, type (GE) K-27J764 to AN-F68925-1	SPECIAL
UG-103A/U	3.62	SC-D-5941			
UG-104/U	3.62	SC-D-5943	UG-128/U	Adapter, type AN-3110-14S-1P to special BTL plug	BTL
UG-105/U	3.62	SC-D-10870			
UG-106/U	3.44 3.62	REB49236	UG-129/U	Adapter, type N plug to special BTL plug	BTL
UG-107B/U	3.44	REB49080			
UG-108A/U	3.19	REB49277	UG-130/U	Adapter, type UHF receptacle to special BTL plug	BTL
UG-109A/U	3.43	RE49F289			
UG-110/U	3.58	SPERRY	UG-131/U	3.58	SC-D-11909
UG-111/U	3.64	AMPHENOL	UG-132/U	Cancelled (Same as UG-178/AP)	
UG-112/AP	Special Adapter	SPECIAL	UG-133/U	90 H-bend elbow for RG-51/U waveguide	WECO.
UG-113/AP	Special Adapter	SPECIAL			
UG-114/U	3.27	RE49F256	UG-134/U	8.8	RE49F551
UG-115/U	3.27	RE49F256	UG-135/U	7.5	MS90059
UG-116/U	7.5	RE49F281	UG-136B/U	7.5	MS90058
UG-117/U	7.5	RE49F281	UG-137B/U	7.5	MS90060
UG-118/TPT-1	Special Adapter	SPECIAL	UG-138/U	7.5	MS90061
UG-119A/UP	Adapter, type N to type UHF	SC-D-12024	UG-139/TPT-1	Adapter, type N receptacle to four type N receptacles	SPECIAL
UG-120/U	90 E-bend elbow for RG-52/U waveguide	WECO.	UG-140/U	11.2	REA49334
UG-121/U	90 E-bend elbow for RG-52/U waveguide	WECO.	UG-141/U	11.2	REA49335
UG-122/U	Special Coupling	BTL	UG-142/U	Replaced by UG-863/U	
UG-123/U	Special Adapter	BTL	UG-143/U	Replaced by UG-715/U	
UG-124/U	Adapter, type UHF to type AN-3100-14-4B	SPECIAL	UG-144/AP	Special Adapter between two UG-40/U choke flanges	RE49A521

^{1/}For latest revisions of drawings, see Section 17.

MIL-HDBK-216
4 January 1962

NOMENCLATURE INDEX - Cont'd

SERVICE TYPE	PAGE NUMBER OR DESCRIPTION	DOCUMENTATION ^{1/}	SERVICE TYPE	PAGE NUMBER OR DESCRIPTION	DOCUMENTATION ^{1/}
UG-145/AP	Special Adapter between two UG-42/U choke flanges	BENARD RICE	UG-166/U	3.50	
UG-146A/U	3.19	REB49042	UG-167E/U	3.45	MS91239
UG-147/U	Adapter, right angle, rotary-joint type	ASTATIC	UG-168/U	3.26	RE49F236
UG-148C/U	7.5	MS90046	UG-169/U	Replaced by UG-156A/U	
UG-149A/U	7.5	MS90047	UG-170/U	Replaced by UG-157A/U	
UG-150/U	7.5	RE49AA280	UG-171/U	3.66	RE49F251
UG-151/TPS-3	Adapter, flexible to rigid coaxial line	SC-D-15144	UG-172/CPS-6	Special Assembly	
UG-152/U	8.8	RE49F413	UG-173/U	3.64	RE49A355
UG-153/U	8.8	RE49F413	UG-174/U	3.50	REB49298
UG-154/U	3.38		UG-175/U	3.64	REA49328
UG-154A/U	3.38		UG-176/U	3.64	REA49329
UG-155/U	3.38		UG-177/U	3.64	AMPHENOL
UG-155B/U	3.38	HEB49153	UG-178/AP	Adapter, right-angle, (MF)	WECO.
UG-156/U	3.39		UG-179/AP	Adapter, antenna to type N jack	SPECIAL
UG-156A/U	3.39	REB49154	UG-180A/U	3.51	HEB49184
UG-157/U	3.39		UG-181A/U	3.51	HEB49209
UG-157B/U	3.39	REB49155	UG-182A/U	3.51	HEB49185
UG-158/U	3.50	GE	UG-183/U	Adapter, type N to RG-52/U waveguide	SPECIAL
UG-159C/U	3.44	REB49081	UG-184/U	Pulse, plug, rubber insert	ASTATIC
UG-160D/U	3.45	REB49082	UG-185/U	Replaced by UG-290A/U	
UG-161/U	3.26	RE49F293	UG-186/U	Adapter, type N plug to RG-52/U waveguide	
UG-162/U	15.2	RE49F338	UG-187/U	Quick-acting clamp for use with RG-44/U	
UG-163/U	Adapter, type UG-81/U to rigid coaxial line	SPECIAL			
UG-164/U	7.5	RE49F588			
UG-165/U	7.5				

^{1/} For latest revisions of drawings, see Section 17.

MIL-HDEK-216
4 January 1962

NOMENCLATURE INDEX - Cont'd

SERVICE TYPE	PAGE NUMBER OR DESCRIPTION	DOCUMENTATION ^{1/}	SERVICE TYPE	PAGE NUMBER OR DESCRIPTION	DOCUMENTATION ^{1/}
UG-188/U	Replaced by UG-536A/U		UG-210/U	7.5	RE49F493
UG-189/U	Replaced by UG-264/U		UG-211/U	7.5	RE49F493
UG-190/U	Adapter, type N to 50-ohm coaxial air line	SPECIAL	UG-212C/U	3.35	REB49254
UG-191/AP	Receptacle, bulk-head type N	ASTATIC	UG-213A/U	3.19	REB49274
UG-192/U	3.26	RE49F236	UG-214/U	7.5	RE49F334
UG-193/U	Pulse, panel jack rubber insert	ASTATIC	UG-215/U	3.38	RE49F344 or SC-C-24612
UG-194A/U	Improved UG-194/U	WECO.	UG-216/U	3.38	REB49158
UG-195A/U	Pulse, panel jack, rubber insert	BTL	UG-216B/U	3.39	
UG-196/U	3.62	AMPHENOL	UG-217A/U	3.19	MIL-A-27434/6
UG-197/U	3.66	RE49F242	UG-218A/U	3.19	MIL-A-27434/7
UG-198/U	3.27	PHILCO	UG-219/U	3.40	
UG-199/APG-15	Adapter, CG-283/APG-15 to UG-24/U plug	GE	UG-219B/U	3.40	REB49159
UG-200/U	Cancelled		UG-220/U	3.40	RE49F348
UG-201A/U	3.19	SC-D-72309 or REB49324	UG-221/U	3.50	RAD. LAB.
UG-202A/U	3.45	REB49032	UG-222/U	3.50	RE49F470
UG-203/U	3.64	RE49F471	UG-222A/U	3.50	REB49189
UG-204C/U	3.45	MS91238	UG-223/U	3.64	RE49F351
UG-205/AP	Adapter, tee, special assembly	WECO.	UG-224/U	3.64	RE49AA50
UG-206/U	3.26	RE49F550	UG-225/APR-10	Special Adapter	BELMONT RADIO
UG-207/U	3.26	RE49F356	UG-226/U	15.2	RE49F385
UG-208/U	3.38		UG-227/U	15.2	RA62F362
UG-208B/U	3.38	REB49156	UG-228/U	Replaced by UG-182A/U	
UG-209/MPM-15	Special Assembly	SC-D-19051	UG-229/U	Replaced by UG-180A/U	
			UG-230/U	Replaced by UG-181A/U	
			UG-231/U	3.45	
			UG-232/U	Special plug, couples to standard banana plug	NATIONAL ELEC. MACH- INE SHOP

^{1/}For latest revisions of drawings, see Section 17.

MIL-HDEK-216
4 January 1962

NOMENCLATURE INDEX - Cont'd

SERVICE TYPE	PAGE NUMBER OR DESCRIPTION	DOCUMENTATION	SERVICE TYPE	PAGE NUMBER OR DESCRIPTION	DOCUMENTATION
UG-233/U	3.24	RE49F364	UG-259A/U	3.19	MIL-A-27434/8
UG-234/U	3.24	RE49F364	UG-260D/U	3.28	MS35170
UG-235/U	Adapter, type UHF to 'JONES' jack	SPECIAL	UG-261C/U	3.28	MS35171
UG-236/U	British Pye type right-angle plug	SPECIAL	UG-262A/U	3.28	
UG-237/U	3.24	RE49F364	UG-262B/U	3.28	
UG-238/U	15.2		UG-262C/U	3.28	MS35172
UG-239/U	3.64		UG-263/U	3.45	RE49F381
UG-240/U	3.40	RE49F367	UG-264/U	3.51	REB49206
UG-241/U	3.19	RE49F373	UG-265/U	Adapter, right angle, type N	ASTATIC
UG-242/U	3.27	RE49F374	UG-266/U	3.64	RE49F511
UG-243/U	3.27	RE49F375	UG-267/U	11.2	RE49F393
UG-244/U	3.27	RE49F376	UG-268/U	11.2	RE49F393
UG-245/U	3.27	RE49F448	UG-269/U	Special Adapter	
UG-246/U	3.27	BTL	UG-270A/U	3.19	MIL-A-27434/9
UG-247/U	7.5	RA10A794	UG-271A/U	3.19	MIL-A-27434/10
UG-248/U	7.5	RE10A794	UG-272/U	3.24	RE49F187
UG-249/U	3.24	RE49F365	UG-273/U	3.19	RE49F389
UG-250/U	3.24	RE49F365	UG-274B/U	3.28	MS35173
UG-251/U	3.24	RE49F365	UG-275/U	3.58	RE49F189
UG-252/U	Cancelled		UG-276/U	3.58	SPEERRY
UG-253B/U	3.28	RE49F418 & RE49F246	UG-277/U	Adapter, for RG-5/U cable	AF45B3792
UG-254A/U	Replaced by UG-911/U		UG-278/U	Pulse, jack, rubber insert	WE
UG-255/U	3.19	RE49F378	UG-279B/U	3.43	REB49285
UG-256/U	3.26	RE49F356	UG-280/U	Receptacle, type N	GEK
UG-257/U	3.26	RE49F356	UG-281/U	3.45	RCA
UG-258/U	3.26	RE49F379	UG-282B/U	3.28	REB49054

1/ For latest revisions of drawings, see Section 17.

NOMENCLATURE INDEX - Cont'd

SERVICE TYPE	PAGE NUMBER OR DESCRIPTION	DOCUMENTATION	SERVICE TYPE	PAGE NUMBER OR DESCRIPTION	DOCUMENTATION
UG-283/U	90° E-bend elbow for RG-48/U waveguide	RAD. LAB.	UG-303/U	Plug, type N	AF45B40991
UG-284/U	90° E-bend elbow for RG-48/U waveguide	RE49F571	UG-304/U	Panel Jack, Type N	AF45D40999
UG-285/U	Replaced by UG-483/U		UG-305/U	Jack, type N	SPECIAL
UG-286/U	Obsolete		UG-306B/U	3.28	MS35368
UG-287/U	3.39	REB49157	UG-307/U	3.64	RE49AA416
UG-287B/U	3.39	REB49157	UG-308/U	15.2	WESTINGHOUSE
UG-288A/U	3.66	REB49317	UG-309/U	3.20	REB49276
UG-289/U	3.66	RE49F481	UG-310/U	Plug, type N	SPECIAL
UG-290A/U	3.28	MS35174	UG-311/U	Jack, type N	SPECIAL
UG-291A/U	3.28		UG-312/U	3.35	
UG-291C/U	3.28	MS35175	UG-313/U	3.26	
UG-292/U	Adapter, right angle type N	AF45B40851	UG-314/U	3.39	RE49F398
UG-293/U	3.43	RRLSK	UG-315/U	3.26	
UG-294/U	Adapter, bulkhead, adapts Navy plug 49195 to Navy plug 49121	RE49F410	UG-316/U	3.26	RE49F436
UG-295/U	3.64	ARMY 71-4991	UG-318/U	3.20	RE49F442
UG-296/U	3.64	ARMY 71-4991	UG-319/U	7.5	WESTINGHOUSE
UG-297A/U	3.64	AF53B13632	UG-320/U	7.5	WESTINGHOUSE
UG-298/U	3.64	ARMY 71-4991	UG-321/U	Plug used with (49194) NAVY Recpt.	WE
UG-299/U	3.64	ARMY 71-4991	UG-322/U	7.5	RE49F464
UG-300/U	3.64	ARMY 71-4991	UG-323/U	7.5	RE49F464
UG-301/UP	Crystal Adapter	SC-D-15595	UG-324/U	Cancelled	
UG-302/U	Adapter, antenna to cable (test set TS-182/UP)	HICKOK ELEC. INSTR. CO.	UG-325/U	15.5	
			UG-326/TPM-7	Adapter, type N to RG-44/U stub-supported coaxial line	SC-D-14930
			UG-327A/U	3.20	MIL-A-27434/11
			UG-328/U	8.8	RE49F466
			UG-329/U	8.8	RE49F467

^{1/} For latest revisions of drawings, see Section 17.

MIL-HDBK-216
4 January 1962

NOMENCLATURE INDEX - Cont'd

SERVICE TYPE	PAGE NUMBER OR DESCRIPTION	DOCUMENTATION	SERVICE TYPE	PAGE NUMBER OR DESCRIPTION	DOCUMENTATION
UG-330/U	8.8	RE49F468	UG-353/U	8.8	WESTINGHOUSE
UG-331/U	8.8	RE49F469	UG-354/U	8.8	WESTINGHOUSE
UG-332/U	Adapter, type UHF to binding post	RE49F565	UG-355/U	Adapter, type N to 726C Klystron tube	GE
UG-333B/U	3.25	REB49234	UG-356/U	Adapter, type N to 2K29 Klystron tube	GE
UG-334B/U	3.25	REB49235	UG-357/U	3.65	BENDIX
UG-335/U	3.20	REB49103	UG-358/U	3.65	BENDIX
UG-336A/U	3.51	REB49186	UG-359/U	3.65	BENDIX
UG-337/U	3.26	RAYTHEON	UG-360/U	3.65	BENDIX
UG-338/U	3.26	RAYTHEON	UG-361/U	Adapter, antenna lead to coaxial socket	SC-D-20927
UG-339/U	11.2	RAYTHEON	UG-362/U	Replaced by UG-290A/U	
UG-340/U	9.2	RE49F449	UG-363/U	3.64	SC-D-62340
UG-341/U	Plug; quick plug in type P/o Navy Model SR-3 & SR-6	WE	UG-364/U	Replaced by UG-290A/U	
UG-342/U	3.27	RE49F514	UG-365/U	Replaced by UG-290A/U	
UG-343B/U	7.6	MS90048	UG-366/U	3.64	WE
UG-344/U	7.6	MS90049	UG-367/U	3.45	RE49F484
UG-345/U	Pulse, receptacle type B, ceramic-insert	CANCELLED	UG-368/U	Male coupler for 1A4ACM (NAVY) waveguide	RE49C625
UG-346/U	15.5	RE49F472	UG-369/U	Female coupler for 1A4ACM (NAVY) waveguide	RE49C626
UG-347A/U	3.86	REB49239	UG-370/U	3.24	PRD
UG-348A/U	3.66	REB49240	UG-371/U	3.24	PRD
UG-349B/U	3.20	SC-D-72331 or REB49102	UG-372/U	3.65	RAYTHEON
UG-350/U	3.50	REB49205	UG-373/U	Replaced by UG-811/U	
UG-351/U	15.5	GILFILLAN BROTHERS	UG-374A/U	Replaced by UG-731/U	
UG-352/U	3.39		UG-375/U	Replaced by UG-827/U	
UG-352B/U	3.39	REB49160			

1/ For latest revisions of drawings, see Section 17.

MIL-HDBK-216
4 January 1962

NOMENCLATURE INDEX - Cont'd

SERVICE TYPE	PAGE NUMBER OR DESCRIPTION	DOCUMENTATION/	SERVICE TYPE	PAGE NUMBER OR DESCRIPTION	DOCUMENTATION/
UG-376A/U	Replaced by UG-715/U		UG-401/U	3.24	AS-2025
UG-377/U	3.27	WE	UG-402A/U	3.24	AF55C54460
UG-378A/U	Replaced by UG-863/U		UG-403/U	9.2	AS-2028
UG-379/U	8.8	RE49F495	UG-404/U	9.2	AS-2033
UG-380/U	8.8	RE49F495	UG-405/U	9.2	AS-2030
UG-381/U	7.6	REB49360	UG-406B/U	7.6	MS90046
UG-382/U	Cancelled		UG-407/U	7.6	MS90047
UG-383/U	7.6	MS90050	UG-408/U	90° E-bend elbow for RG-68/U Waveguide	WESTINGHOUSE
UG-384/U	Cancelled		UG-409/U	Adapter, RG-81/U to RG-82/U cable for underwater use	USNUSL
UG-385/U	7.6	MS90050	UG-410/U	3.64	AIR MARINE INST. CORP.
UG-386/U	Cancelled		UG-411/U	Receptacle, mates with UG-412/U	BENDIX
UG-387/U	7.6	MS90050	UG-412/U	Receptacle, mates with UG-411/U	BENDIX
UG-388/U	Cancelled		UG-413/U	3.35	REB49231
UG-389A/U	8.8	RE49F495	UG-414A/U	3.28	REB49071
UG-390/U	Receptacle, type LC, part of rotary switch	DESIGNERS FOR INDUS.	UG-415A/U	3.66	REB49241
UG-391/U	Receptacle, special, part of rotary switch	DESIGNERS FOR INDUS.	UG-416A/U	3.66	REB49242
UG-392/U	Receptacle, type N, part of rotary switch	DESIGNERS FOR INDUS.	UG-417A/U	7.6	MS90052
UG-393/U	Receptacle, type N, part of rotary switch	DESIGNERS FOR INDUS.	UG-418A/U	7.6	MS90052
UG-394/U	Receptacle, type N, part of rotary switch	DESIGNERS FOR INDUS.	UG-419/U	7.6	MS90063
UG-395/U	Flange for 14ACM (Navy) Waveguide	RE49F464	UG-420/U	Replaced by UG-419/U	
UG-396/U	Cancelled		UG-421B/U	3.62	MIL-C-3655/1
UG-397/U	9.2	AS-2022	UG-422/U	3.62	MIL-C-3655/2
UG-398/U	9.2	AS-2023	UG-423B/U	3.62	MIL-C-3655/3
UG-399/U	9.2	AS-2032	UG-424/U	Special plug	FED. MFG. & ENG. CORP.
UG-400/U	9.2	AS-2038			

¹For latest revisions of drawings, see Section 17.

MIL-HDEK-216
4 January 1962

NOMENCLATURE INDEX - Cont'd

SERVICE TYPE	PAGE NUMBER OR DESCRIPTION	DOCUMENTATION/	SERVICE TYPE	PAGE NUMBER OR DESCRIPTION	DOCUMENTATION/
UG-425/U	7.6	REB49359	UG-454/U	8.9	AS-2066
UG-427C/U	3.35	REB49223	UG-455/U	8.9	AS-2064
UG-428/U	Plug; type N	HAZELTINE	UG-456/U	8.9	AS-2054
UG-429/U	Phaser section	TERPENING	UG-457/U	8.9	AS-2069
UG-430/U	Phaser section	TERPENING	UG-458/U	8.9	AS-2042
UG-431/U	Phaser section	TERPENING	UG-459/U	8.9	AS-2045
UG-432/U	Phaser section	TERPENING	UG-460/U	8.9	AS-2039
UG-433/U	Phaser section	TERPENING	UG-461/U	8.9	AS-2073
UG-434/U	Choke flange, for RG-104/U Waveguide	SPECIAL	UG-462/U	8.9	AS-2067
UG-435A/U	7.6	MS90053	UG-463/U	8.9	AS-2055
UG-436/U	Choke flange, for RG-105/U Waveguide	SPECIAL	UG-464/U	3.45	REB49085
UG-437A/U	7.6	MS90053	UG-465/U	11.2	AS-2043
UG-438A/U	Replaced by UG-585/U		UG-466/U	11.2	AS-2056
UG-439/U	Replaced by UG-584/U		UG-467/U	8.9	AS-2063
UG-440B/U	7.6	MS90048	UG-468/U	8.9	AS-2065
UG-441/U	7.6	MS90049	UG-469/U	8.9	AS-2061
UG-443/CRN-10	Special Adapter	SPECIAL	UG-470/U	8.9	AS-2074
UG-444/CRN-10	Special Adapter	SPECIAL	UG-471/U	8.9	AS-2068
UG-445/U	9.2	AS-2027	UG-472/U	8.9	AS-2070
UG-446A/U	9.2	AF54B54901	UG-473/U	8.9	AS-2062
UG-447/U	3.28	BENDIX	UG-474/U	Waveguide adapter	AS-2040
UG-448/U	8.8	AS-2060	UG-475/U	Replaced by UG-413/U	
UG-449/U	8.8	AS-2053	UG-476/U	Cancelled (use) UG-415/U	
UG-450/U	8.9	AS-2044	UG-477/U	Adapts single wire to coaxial socket	
UG-451/U	8.9	AS-2041	UG-478/U	3.16	RE49F522
UG-452/U	8.9	AS-2059	UG-479/U	3.66	RE49F523
UG-453/U	8.9	AS-2058	UG-480/U	3.66	RE49F524

²For latest revisions of drawings, see Section 17.

NOMENCLATURE INDEX - Cont'd

SERVICE TYPE	PAGE NUMBER OR DESCRIPTION	DOCUMENTATION ^{1/}	SERVICE TYPE	PAGE NUMBER OR DESCRIPTION	DOCUMENTATION ^{1/}
UG-481/U	3.66	RE49F525	UG-506A/U	3.66	REC49257
UG-482/U	3.66	RE49F526	UG-507A/U	3.67	REC49255
UG-483/U	3.45	REB49086	UG-508/U	11.2	RE49F552
UG-484/U	3.45	REB49087	UG-509/U	7.6	RE49F554
UG-485/U	Elbow, for use with RG-52/U Waveguide	SPECIAL	UG-510/U	7.6	RE49F554
UG-486/U	3.45	REB49088	UG-511/U	7.6	RE49F555
UG-487/U	3.45	REB49089	UG-512/U	7.6	RE49F555
UG-488/U	Adapter to special antennas	AF49B12678	UG-513/U	Adapter, Crystal socket part of crystal test set TS-546 ()/U	EBY
UG-489/CPS-6E	Special assembly	AMF	UG-514/U	Adapter, part of audio oscillator TS-382A/U	AF50C12863
UG-490/U	Adapter, RG-48/U Waveguide to RG-44/U coaxial line	BENDIX	UG-515/CPS-6B	Adapts coaxial magnetron output coupling to rectangular waveguide	KINGS ELEC.
UG-491B/U	3.28	MS35176	UG-516A/U	3.20	MIL-A-27434/14
UG-492D/U	3.28	MS35177	UG-518/U	3.24	AS-2037
UG-493A/U	3.62	MIL-C-3655/4	UG-519/U	3.24	AS-2034
UG-494A/U	3.35	REB49217	UG-520/U	9.2	AS-2026
UG-495D/U	3.35	REB49031 or AF56C57289	UG-521/U	9.2	AS-2024
UG-496/U	3.35	REB49219	UG-522/U	9.2	AS-2035
UG-497A/U	3.20	MIL-A-27434/13	UG-523/U	9.2	AS-2029
UG-498/U	3.66	REB49243	UG-524/U	Receptacle, part of dummy load TS-214/UP	WEC0
UG-499A/U	3.66	REB49244	UG-525/U	Receptacle, part of dummy load TS-234/UP	WEC0
UG-500/U	9.2	GE	UG-526/U	3.67	RCA
UG-501/U	3.66	RE49F537	UG-527/U	3.28	BENDIX
UG-502/U	3.66	RE49F538	UG-528/U	Adapter, part of signal generator SC-1/ARN	BOONRACO
UG-503/U	3.66	RE49F539			
UG-504/U	3.66	RE49F540			
UG-505A/U	3.66	REC49310			

^{1/}For latest revisions of drawings, see Section 17.

MIL-HDBK-216

4 January 1962

NOMENCLATURE INDEX - Cont'd

SERVICE TYPE	PAGE NUMBER OR DESCRIPTION	DOCUMENTATION ^{1/}	SERVICE TYPE	PAGE NUMBER OR DESCRIPTION	DOCUMENTATION ^{1/}
UG-529/U	Adapter, part of Signal generator SG-1/ARN	BOONRACO	UG-548/U	Adapter, right angle, between RG-69/U and coaxial cable	WESTINGHOUSE
UG-530/U	3.43	RE49F560	UG-549/U	15.5	WESTINGHOUSE
UG-531/U	3.43	RE49F561	UG-550/U	Adapter, right angle, part of radio set AN/MRC-2	SC-C-21831
UG-532A/U	3.40	REB49161	UG-551A/U	9.2	MARYLAND ELEC. MFG.
UG-533B/U	3.40	REB49162	UG-552/U	9.2	AF50C5507 or REB49351
UG-534B/U	3.40	REB49163	UG-553/U	7.6	MS90051
UG-535/U	3.28	RE49F568	UG-554/U	7.6	MS90051
UG-535A/U	Assigned new nomenclature UG-1098/U		UG-555/U	3.43	AF50B13081
UG-536B/U	3.45	REB49090	UG-556B/U	3.45	REB49378
UG-537/U	Adapter, part of radio test set AN/URM-6	STODDART AIRCRAFT	UG-557A/U	3.45	REB49249
UG-538/U	Adapter, connects coaxial cable to waveguide	BENDIX	UG-558/U		BARLOW
UG-539/U	Adapter, part of standing wave meter TS-130A/UP	AF49B56481	UG-559B/U	3.20	MIL-A-27434 /15
UG-540/U	Adapter, part of standing wave meter TS-130A/UP	AF49B56475	UG-560/U	3.35	AMPHENOL
UG-541A/U	7.6	MS90062	UG-564/U	3.20	MIL-A-27434 /1
UG-542/U	3.58		UG-565A/U	3.20	MIL-A-27434 /2
UG-543/U	Receptacle, part of radio test set AN/URM-6	BOONTON RADIO CORP.	UG-566A/U	3.32	MS35320
UG-544/U	Receptacle, part of radio test set AN/URM-6	STODDART AIRCRAFT	UG-567A/U	3.32	MS35322
UG-545/U	Adapter, used on RF switch SA-191/SLT-1	GE	UG-568/U	3.32	MS35319
UG-546/U	Plug used on RF switch SA-191/SLT-1	GE	UG-569A/U	3.32	MS35323
UG-547/U	Adapter, right angle, between RG-69/U and rotary coupler	WESTINGHOUSE	UG-570A/U	3.32	MS35317
			UG-571A/U	3.32	MS35316
			UG-572A/U	3.32	MS35318
			UG-573B/U	3.32	MS35315
			UG-574A/U	Plug, special, for use with type N series	AF50B13336

^{1/}For latest revisions of drawings, see Section 17.

MIL-HDBK-216
4 January 1962

NOMENCLATURE INDEX - Cont'd

SERVICE TYPE	PAGE NUMBER OR DESCRIPTION	DOCUMENTATION ^{1/}	SERVICE TYPE	PAGE NUMBER OR DESCRIPTION	DOCUMENTATION ^{1/}
UG-575/U	Receptacle, special, for use with type N series	AF50B13338	UG-597/U	7.6	MS90056
UG-576/U	Special adapter, coaxial line to waveguide	BARLOW	UG-598A/U	7.6	MS90054
UG-577/U	Special adapter, coaxial line to waveguide	BARLOW	UG-599/U	7.6	MS90057
UG-578/U	Special adapter, coaxial line to waveguide	BARLOW	UG-600A/U	7.6	MS90055
UG-579/U	8.9	AFX50D54284	UG-601/CPN-18	Adapts RF-5586 magnetron tube of radar transmitter T-258/CPN-18 to Duplex CU-244/CPN-18	BENDIX
UG-580/U	8.9	AFX50D54285	UG-602A/U	3.45	REB49212
UG-581/U	Universal connector between airfilled line to N connector	SPECIAL	UG-603A/U	3.45	REB49211
UG-582/U	3.25		UG-604/U	3.29	BENDIX
UG-583/U	3.25		UG-605/U	3.20	MIL-A-27434/18
UG-584/U	7.6	MS90045	UG-606/U	3.20	MIL-A-27434/19
UG-585A/U	7.6	MS90044	UG-607/U	Adapts high voltage output of power transformer TF-134/URM-16 to receptacle UG-181A/U	SPECIAL
UG-586B/U	3.20	MIL-A-27434/16	UG-608/U	Adapts high-voltage output of power transformer TF-134/URM-16 to plug UG-180A/U	BUGGIE
UG-587B/U	3.20	MIL-A-27434/17	UG-609/U	Adapts high voltage output of power transformer TF-134/URM-16 to receptacle UG-182A/U	BUGGIE
UG-589/U	3.29	SC-C-5187	UG-610/U	Adapts high voltage output of power transformer TF-134/URM-16 to plug UG-34/U	BUGGIE
UG-590/U	Clamp, for clamping UG-135/U and UG-136/U together.	SPERRY	UG-611/U	Adapts high-voltage output of power transformer TF-134/URM-16 to receptacle UG-36/U	BUGGIE
UG-591/U	9.2	SPERRY			
UG-592/U	9.2	SPERRY			
UG-593A/U	3.45	REB49212			
UG-594A/U	3.45	AF50B13388			
UG-595/U	7.6	MS90056			
UG-596A/U	7.6	MS90054			

^{1/}For latest revisions of drawings, see Section 17.

MIL-HDBK-216
4 January 1962

NOMENCLATURE INDEX - Cont'd

SERVICE TYPE	PAGE NUMBER OR DESCRIPTION	DOCUMENTATION ^{1/}	SERVICE TYPE	PAGE NUMBER OR DESCRIPTION	DOCUMENTATION ^{1/}
UG-612/U	Choke flange for use with RF line CAY-14-ACM		UG-623/U	Adapter-connector for use with 6,000 volt d.c. connectors; used in military aircraft	AF50D13810
UG-613A/U	Crystal socket adapter	MIL-M-5818 (AF)	UG-624/U	3.29	AS-2108
UG-614A/U	Crystal socket adapter	MIL-M-5818 (AF)	UG-625B/U	3.29	MS27035
UG-615/U	Consists of plug PL-259 one end; connector MC-80 other end	TRANSDUCER CORP.	UG-626B/U	3.32	MS35280
UG-616/U	Plug connector used in military aircraft; high voltage d.c.; similar to standard connectors, except smaller, lighter, and for d.c. only	AF50C13794	UG-627B/U	3.32	MS35286
UG-617/U	Receptacle for use with 3000 volt d.c. connectors and cables	AF50C13792	UG-628B/U	Cancelled	
UG-618/U	Plug connector for use with 3,000 volt d.c. connectors and cables; used in military aircraft	AF50C13786	UG-629/U	3.32	MS35330
UG-619/U	Adapter, connector for use with 3,000 volt d.c. connectors; used in military aircraft	AF50C13782	UG-630A/U	3.32	MS35284
UG-620/U	Plug connector for use with 6,000 volt connectors and cables for use in military aircraft	AF50D13798	UG-631A/U	3.32	MS35279
UG-621/U	Receptacle for use with 6,000 volt d.c. connectors and cables; used in military aircraft	AF50D13807	UG-632A/U	Cancelled	
UG-622/U	Plug connector for use with 6,000 volt d.c. connectors and cables used in military aircraft	AF50D13805	UG-633A/U	3.32	MS35328
			UG-634/U	Cancelled	
			UG-635/U	3.20	MIL-A-27434/3
			UG-636A/U	3.21	MIL-A-27434/4
			UG-637/U	3.21	MIL-A-27434/5
			UG-638/U	Waveguide adapter part of antenna drive AS-481(AF-1)/SPS-7	SYLVANIA
			UG-639/U	Cancelled	
			UG-640D/U	16.5	REB49145
			UG-641/U	3.29	SC-C-48783
			UG-642A/U	3.32	MS35287
			UG-643/U	3.32	MS35288
			UG-644/U	Cancelled	
			UG-645/U	15.5	RAYTHEON

^{1/}For latest revisions of drawings, see Section 17.

MIL-HDEK-216
4 January 1962

NOMENCLATURE INDEX - Cont'd

SERVICE TYPE	PAGE NUMBER OR DESCRIPTION	DOCUMENTATION ^{1/}	SERVICE TYPE	PAGE NUMBER OR DESCRIPTION	DOCUMENTATION ^{1/}
UG-646/U	3.64	RAYTHEON	UG-669/U	16.5	USN USL
UG-647/U	9.2		UG-670	16.5	RE49D611
UG-648/U	8.9	AS-2060	UG-671/U	16.5	USN USL
UG-649/U	8.9	AS-2058	UG-672B/U	16.5	REB49147
UG-650/U	8.9	AS-2054	UG-673/U	Waveguide adapter p/o Radar set AN/CPN-4 and AN/FPN-16, Adapts transmission line to antenna array (feed end)	R-7437(AF)
UG-651/U	Electrical clamp	WESTINGHOUSE	UG-674/U	Adapter, waveguide to coax (special)	R-7437(AF)
UG-652/U	Electrical clamp	WESTINGHOUSE	UG-675/U	Part of antenna As-519/GPN; used to attenuate and lead X-band radar and feed energy to coaxial line	R-7437(AF)
UG-653/U	RF line cap; gas-tight end terminal for terminating pressurized RF lines	WESTINGHOUSE	UG-676/U	90° elbow for use with RF transmission line RG-128/U	PDC
UG-654/U	RF line cap; gas-tight end terminal for terminating pressurized RF lines	WESTINGHOUSE	UG-677/U	11.2	REB49314
UG-655/U	RF line elbow; RF line section used for changing direction 90°	WESTINGHOUSE	UG-678/U	3.67	RE49D608
UG-656/U	RF line elbow; RF line section used for changing direction 45°	WESTINGHOUSE	UG-679/U	3.67	RE49D609
UG-657/U	3.29	SC-C-41141	UG-680A/U	3.45	AF51B13712
UG-658/U	8.9	AS-2066	UG-681/U	Coaxial to waveguide adapter, adapts a "Midwest" connector type 102207 to a 1-1/4" x 5/8" waveguide	MIDWEST ENG. DEV. CO.
UG-659/U	8.9	AS-2064	UG-682/U	Crystal socket provides snap in connection for crystal holder HC-10/U	SPECIAL
UG-660/U	8.9	AS-2069	UG-683/U	Crystal socket adapter; adapts a crystal socket to accommodate crystal holder HC-10/U	EBY
UG-662/U	Antenna adapter	BuAER E-1795	UG-684A/U	Adapter, connector; adapts a ENC male to PJ-055 phone jack	TRAD
UG-664/U	Male to male adapter which provides capacitive coupling between a crystal and loop coupling	HAZELTINE			
UG-665E/U	16.5	REB49146			
UG-666/U	16.5	RE49D612			
UG-667/U	16.5	USN USL			
UG-668/U	16.5	USN USL			

^{1/}For latest revisions of drawings, see Section 17.

MIL-HDBK-216
4 January 1962

NOMENCLATURE INDEX - Cont'd

SERVICE TYPE	PAGE NUMBER OR DESCRIPTION	DOCUMENTATION ^{1/}	SERVICE TYPE	PAGE NUMBER OR DESCRIPTION	DOCUMENTATION ^{1/}
UG-686/TPS-10D	15.5	RCA	UG-714/U	8.10	MS35156
UG-687/U	9.2	ESPEY	UG-715/U	8.10	do
UG-688/U	9.2	ESPEY	UG-716/U	8.10	do
UG-689/UPM-25		ESPEY	UG-717/U	8.10	do
UG-690/U	3.21	MIL-A-27434/20	UG-718/U	8.10	do
UG-691/U	3.21	MIL-A-27434/21	UG-719/U	8.10	do
UG-692/U	3.59	MS35115(SC)	UG-720/U	8.10	do
UG-693/U	3.59	MS35116(SC)	UG-721/U	8.10	do
UG-694/U	3.59	MS35117(SC)	UG-722/U	8.10	do
UG-695/U	3.59	MS35118(SC)	UG-723/U	8.10	do
UG-696/U	3.59	MS35119(SC)	UG-724/U	8.10	do
UG-697/U	3.59	MS35120(SC)	UG-725/U	8.10	do
UG-698/U	3.59	MS35121(SC)	UG-726/U	8.10	do
UG-699/U	3.59	MS35122(SC)	UG-727/U	8.10	do
UG-700/U	3.59	MS35123(SC)	UG-728/U	8.10	MS35157
UG-701/U	3.32	MS90266	UG-729/U	8.10	do
UG-702/U	3.21	MS90253	UG-730/U	8.10	do
UG-703A/U	3.21	MS90261	UG-731/U	8.10	do
UG-704A/U	3.32	MS90227	UG-732/U	8.25	do
UG-705/U	3.32	MS90273	UG-733/U	8.25	do
UG-706/U	3.33	MS90248	UG-734/U	8.25	do
UG-707A/U	3.33	MS90233	UG-735/U	8.25	do
UG-708B/U	3.33	MS90247	UG-736/U	8.25	do
UG-709B/U	3.33	MS90214	UG-737/U	8.11	do
UG-710B/U	3.33	MS90237	UG-738/U	8.11	do
UG-711B/U	3.33	MS90244	UG-739/U	8.11	do
UG-712/U	8.10	MS35156	UG-740/U	8.11	do
UG-713/U	8.10	MS35156	UG-741/U	8.11	do
			UG-742/U	8.11	do

^{1/}For latest revisions of drawings, see Section 17.

NOMENCLATURE INDEX - Cont'd

SERVICE TYPE	PAGE NUMBER OR DESCRIPTION	DOCUMENTATION ^{1/}	SERVICE TYPE	PAGE NUMBER OR DESCRIPTION	DOCUMENTATION ^{1/}
UG-743/U	8.11	MS35157	UG-771/U	8.12	MS35159
UG-744/U	8.11	MS35158	UG-772/U	8.12	do
UG-745/U	8.11	do	UG-773/U	8.12	do
UG-746/U	8.11	do	UG-774/U	8.13	do
UG-747/U	8.11	do	UG-775/U	8.13	do
UG-748/U	8.11	do	UG-776/U	8.13	MS35160
UG-749/U	8.11	do	UG-777/U	8.13	do
UG-750/U	8.11	do	UG-778/U	8.13	do
UG-751/U	8.11	do	UG-779/U	8.25	do
UG-752/U	8.11	do	UG-780/U	8.13	do
UG-753/U	8.11	do	UG-781/U	8.13	do
UG-754/U	8.11	do	UG-782/U	8.13	do
UG-755/U	8.11	do	UG-783/U	8.13	do
UG-756/U	8.12	do	UG-784/U	8.13	do
UG-757/U	8.12	do	UG-785/U	8.13	do
UG-758/U	8.12	do	UG-786/U	8.13	do
UG-759/U	8.12	do	UG-787/U	8.13	do
UG-760/U	8.12	MS35159	UG-788/U	8.13	do
UG-761/U	8.12	do	UG-789/U	8.13	do
UG-762/U	8.12	do	UG-790/U	8.13	do
UG-763/U	8.12	do	UG-791/U	8.13	do
UG-764/U	8.12	do	UG-792/U	8.13	MS35161
UG-765/U	8.12	do	UG-793/U	8.14	do
UG-766/U	8.12	do	UG-794/U	8.14	do
UG-767/U	8.12	do	UG-795/U	8.14	do
UG-768/U	8.12	do	UG-796/U	8.14	do
UG-769/U	8.12	do	UG-797/U	8.14	do
UG-770/U	8.12	do	UG-798/U	8.14	do

^{1/}For latest revisions of drawings, see Section 17.

MIL-HDBK-216

4 January 1962

NOMENCLATURE INDEX - Cont'd

SERVICE TYPE	PAGE NUMBER OR DESCRIPTION	DOCUMENTATION ^{1/}	SERVICE TYPE	PAGE NUMBER OR DESCRIPTION	DOCUMENTATION ^{1/}
UG-799/U	8.14	MS35161	UG-828/U	8.15	MS35163
UG-800/U	8.14	do	UG-829/U	8.15	do
UG-801/U	8.14	do	UG-830/U	8.15	do
UG-802/U	8.25	do	UG-831/U	8.15	do
UG-803/U	8.14	do	UG-832/U	8.16	do
UG-804/U	8.14	do	UG-833/U	8.16	do
UG-805/U	8.14	do	UG-834/U	8.16	do
UG-806/U	8.14	do	UG-835/U	8.16	do
UG-807/U	8.14	do	UG-836/U	8.16	do
UG-808/U	8.14	MS35162	UG-837/U	8.16	do
UG-809/U	8.14	do	UG-838/U	8.16	do
UG-810/U	8.14	do	UG-839/U	8.16	do
UG-811/U	8.14	do	UG-840A/CPS-6B	A coaxial to waveguide adapter used to provide a means of connecting the coaxial magnetron output to a 1-1/2 x 3 inch rectangular waveguide	GE
UG-812/U	8.14	do			
UG-813/U	8.15	do			
UG-814/U	8.15	do			
UG-815/U	8.15	do	UG-841/FPS-6	9.2	GE
UG-816/U	8.15	do	UG-842/FPS-6	90° waveguide elbow to connect from receiver arm of duplexer to transmit-receive tube	GE
UG-817/U	8.15	do			
UG-818/U	8.15	do			
UG-819/U	8.15	do	UG-843/FPS-6	180° waveguide elbow to connect from a duplexer to a bi-directional coupler	GE
UG-820/U	8.15	do			
UG-821/U	8.15	do			
UG-822/U	8.15	do	UG-844/U	8.16	MS35164
UG-823/U	8.15	do	UG-845/U	8.16	do
UG-824/U	8.15	MS35163	UG-846/U	8.16	do
UG-825/U	8.15	do	UG-847/U	8.16	do
UG-826/U	8.15	do	UG-848/U	8.16	do
UG-827/U	8.15	do	UG-849/U	8.16	do

^{1/}For latest revisions of drawings, see Section 17.

MIL-HDBK-216
4 January 1962

NOMENCLATURE INDEX - Cont'd

SERVICE TYPE	PAGE NUMBER OR DESCRIPTION	DOCUMENTATION ^{1/}	SERVICE TYPE	PAGE NUMBER OR DESCRIPTION	DOCUMENTATION ^{1/}
UG-850/U	8.16	MS35164	UG-879/U	8.18	MS35166
UG-851/U	8.16	do	UG-880/U	8.18	do
UG-852/U	8.16	do	UG-881/U	8.18	do
UG-853/U	8.16	do	UG-882/U	8.18	do
UG-854/U	8.16	do	UG-883/U	8.18	do
UG-855/U	8.17	do	UG-884/U	8.18	do
UG-856/U	8.17	do	UG-885/U	8.18	do
UG-857/U	8.17	do	UG-886/U	8.18	do
UG-858/U	8.17	do	UG-887/U	8.18	do
UG-859/U	8.17	do	UG-888/U	8.18	do
UG-860/U	8.17	MS35165	UG-889/U	8.18	do
UG-861/U	8.17	do	UG-890/U	8.18	do
UG-862/U	8.17	do	UG-891/U	8.18	do
UG-863/U	8.25	do	UG-892/U	8.18	do
UG-864/U	8.17	do	UG-893/U	8.18	MS35167
UG-865/U	8.17	do	UG-894/U	8.18	do
UG-866/U	8.17	do	UG-895/U	8.19	do
UG-867/U	8.17	do	UG-896/U	8.19	do
UG-868/U	8.17	do	UG-897/U	8.19	do
UG-869/U	8.17	do	UG-898/U	8.19	do
UG-870/U	8.17	do	UG-899/U	8.19	do
UG-871/U	8.17	do	UG-900/U	8.19	do
UG-872/U	8.17	do	UG-901/U	8.19	do
UG-873/U	8.17	do	UG-902/U	8.19	do
UG-874/U	8.17	do	UG-903/U	8.19	do
UG-875/L	8.18	do	UG-904/U	8.19	do
UG-876/U	Special	—	UG-905/U	8.19	do
UG-877/U	8.18	MS35166	UG-906/U	8.19	do
UG-878/U	8.18	do	UG-907/U	8.19	do

^{1/}For latest revisions of drawings, see Section 17.

MIL-HDBK-216

4 January 1962

NOMENCLATURE INDEX - Cont'd

SERVICE TYPE	PAGE NUMBER OR DESCRIPTION	DOCUMENTATION ^{1/}	SERVICE TYPE	PAGE NUMBER OR DESCRIPTION	DOCUMENTATION ^{1/}
UG-908/U	8.19	MS35167	UG-925B/U	3.35	REB49226
UG-909B/U	3.29	MS35180	UG-926A/U	3.35	REB49220
UG-910B/U	3.29	MS35181	UG-927B/U	3.35	REB49230
UG-911A/U	3.29	MS35182	UG-928/U	3.29	IPC 1100
UG-912A/U	3.29	MS35183	UG-929B/U	3.35	REB49225
UG-913A/U	3.29	MS35367	UG-930B/U	3.35	REB49229
UG-914/U	3.29	MS35184	UG-931/U	3.67	SC-C-83125
UG-915/U	Crystal socket so designed so that a series N plug and Jack can be unmated and a crystal socket inserted in circuit	DIAMOND	UG-932A/U	3.67	REB49066
UG-916/U	15.2	AF52C12837	UG-933/U	7.6	RCA
UG-917/U	Coaxial to waveguide adapter, adapts coaxial line in receiver transmitter unit to external waveguide run		UG-934A/U	3.54	REB49119
UG-918/U	Connector, adapter; used to adapt input of radio receiver R-438()/ARN-26AY to existing antenna installations	CLASSIFIED	UG-935B/U	3.45	MS90292
UG-919/U	Connector adapter; used to adapt input of radio receiver R-196()/ARN-26Y to existing antenna installations	SUTCHELL-CARLSON	UG-936B/U	3.45	REB49092
UG-920/U	Replaced by UG-212C/U		UG-937A/U	3.33	MS35317 and MS90277 or REB49191
UG-921/U	3.43	AF52B13089	UG-938A/U	3.33	MS35316 and MS90277
UG-922/UPN	Antenna to transmitter adapter. A loading adapter consisting of 5 composition resistors	SPECIAL	UG-939A/U	3.33	MS35329 and MS90277
UG-923/U	3.59	MS35124(SC)	UG-940B/U	3.45	MS90292
UG-924/U	Replaced by UG-282A/U		UG-941B/U	3.45	MS90293
			UG-942B/U	3.33	MS35285 and MS90277
			UG-943B/U	3.33	REB49195
			UG-944A/U	3.33	REB49193
			UG-945B/U	3.33	MS90237 and MS90277
			UG-946/U	3.54	REB49120
			UG-947/U	Test adapter, adapts actual base of crystal unit DC-9 to two-spring sockets	SC-B-9985
			UG-948A/FPS-3	Special waveguide to coaxial adapter	HENDIX

^{1/} For latest revisions of drawings, see Section 17.

NOMENCLATURE INDEX - Cont'd

SERVICE TYPE	PAGE NUMBER OR DESCRIPTION	DOCUMENTATION ^{1/}	SERVICE TYPE	PAGE NUMBER OR DESCRIPTION	DOCUMENTATION ^{1/}
UG-949/U	Receptacle connector 10 female, round, polarized contacts	CANNON	UG-968B/U	3.55	REB49123
			UG-969/U	3.62	SC-C-12444
UG-950/FPS/6	Transmission line rotary coupler, couples transmission line to provide 35 elevation movement	GE	UG-970/U	3.25	MIL-A-27434/23
			UG-971/U	3.21	MIL-A-27434/24
			UG-972B/U	3.55	REB49124
UG-951/FPS/6	180° waveguide elbow part of transmission lines conducting RF energy to antenna of Radar Set AN/FPS-6	GE	UG-973/U	8.20	CWS
			UG-974/U	8.20	CWS
			UG-975/U	3.67 16.5	REC49256
UG-952/U	9.2	MICROWAVE DEV. LAB.	UG-976/U	3.55	REB49125
UG-953/U	9.2	SPECIALTY SPRAYING & MACHINE CO.	UG-977A/U	3.21	MIL-A-27434/25
			UG-978/U	3.67	
UG-954/U	7.7	REA49297	UG-979/U	7.7	WESTINGHOUSE
UG-955/U	8.19	RE49D693	UG-980B/U	16.5	REB49148
UG-956/U	8.19	RE49D694	UG-981/U	3.62	MIL-C-3655/5
UG-957/U	8.19	RE49D695	UG-982/U	3.46	REB49095
UG-958/U	8.19	RE49D696	UG-983A/U	16.5	REB49149
UG-959A/U	3.29	SC-C-107602	UG-984/FPS-8	161° waveguide elbow p/o Radar set AN/FPS-8 transmission line	TITEFLEX
UG-960/FPS-6	Rotary coupler designed to permit 360 azimuth travel of AN/FPS-6 antenna elements	GE	UG-985A/FPS-8	15.5	GE
			UG-986C/U	16.5	REB49150
UG-961A/U	3.67	REB49065	UG-987/U	3.67	GE
UG-962/FPS-8	8.19	GE	UG-988D/U	16.5	REB49151
UG-963/FPS-8	8.19	GE	UG-989A/U	3.54	REB49127
UG-964/U	3.67		UG-990/U	8.20	RATHEON
UG-965A/U	3.25	REB49315	UG-991/U	8.20	RATHEON
UG-966/U	3.21	MIL-A-27434/22	UG-994/FPS-8	90° elbow w/cast on flanges; part of AN/FPS-8	GE
UG-967B/U	3.55	REB49122			

^{1/}For latest revisions of drawings, see Section 17.

MIL-EDHK-216
4 January 1962

NOMENCLATURE INDEX - Cont'd.

SERVICE TYPE	PAGE NUMBER OR DESCRIPTION	DOCUMENTATION ^{1/}	SERVICE TYPE	PAGE NUMBER OR DESCRIPTION	DOCUMENTATION ^{1/}
UG-995/FPS-8	Waveguide to coaxial adapter p/o Radar Set AN/FPS-8	GE	UG-1015/MPS-14	60° elbow, to be used between Radar Set group OA-357/FPS-6 and Antenna group OA-389/FPS-6	GE
UG-996/U	8.20	CWS			
UG-997A/U	3.46	REB49245	UG-1016A/U	3.67	REB49059
UG-998/U	3.21		UG-1017/U	3.67	REB49252 or SC-C-86341
UG-999A/U	3.21	BIRD ELEC.			
UG-1000/U	Similar to UG-536/U; connects RG-58/U cable to special antenna plug	USN USL	UG-1018/U	3.46	RE49D677
			UG-1019/U	3.36	DIAMOND
UG-1001/U	9.2	GRANITE STATE MACHINE	UG-1020A/U	3.54	REB49130
			UG-1021A/U	3.36	REB49218
UG-1002/U	9.2	do	UG-1022/U	3.43	REB49337
UG-1003/U	3.46	IPC	UG-1023/U	9.2	AS-2031
UG-1004/U	9.2	RE49D674	UG-1024/U	Special Antenna adapter	WARD PROD.
UG-1005/U	9.2	RE49D675	UG-1025/U	3.26	GE
UG-1006/U	3.46	REB49096	UG-1026/U	9.2	GE
UG-1007A/GPX-13	Adapts waveguide assembly CG-537/U to twin coaxial RF transmission line	HAZELTINE	UG-1027/U	7.7	GE
			UG-1028/U	Special waveguide assembly	GE #P-9785563P1
UG-1008A/GPX-13	7.7	HAZELTINE	UG-1029/U	Special waveguide assembly	GE #P-9785566P1
UG-1009/GPX-13	Coaxial to waveguide adapter p/o antenna modification kit MX-1233/GPX-13	RE49D670	UG-1030/U	Special waveguide assembly	GE #P-9785565P1
			UG-1031/U	9.2	GE
UG-1010/U	3.55	REB49128	UG-1032/U	3.33	
UG-1013A/U	3.21	MIL-A-27434/26	UG-1033/U	3.29	SC-D-98508
			UG-1034/U	3.21	MIL-C-27434/27
UG-1014/MPS-14	90° elbow, to be used between Radar Set Group OA-537/FPS-6 and Antenna group OA-389/FPS-6	GE	UG-1035/U	3.67	
			UG-1036/BLR-1	Adapts RG-9/U to UG-110/U (MIL-D-15653) (Ships)	SPECIAL

^{1/}For latest revisions of drawings, see Section 17.

MIL-HDBK-216
4 January 1962

NOMENCLATURE INDEX - Cont'd

SERVICE TYPE	PAGE NUMBER OR DESCRIPTION	DOCUMENTATION ^{1/}	SERVICE TYPE	PAGE NUMBER OR DESCRIPTION	DOCUMENTATION ^{1/}
UG-1037/BLR-1	Adapts RG-9/U to UG-109/U (MIL-D-15653) (Ships)	SPECIAL	UG-1061A/U	3.54	REB49253
			UG-1062/U	3.67	BARLOW
UG-1038/BLR-1	Plain waveguide flange MIL-D-15653 (Ships)	SPECIAL	UG-1063/U	Cancelled	
			UG-1064/U	Cancelled	
UG-1039/BLR-1	Plain waveguide flange MIL-D-15653 (Ships)	SPECIAL	UG-1065/U	Cancelled	
			UG-1066/U	Cancelled	
UG-1040/FPS-13	Rotary coupler serves as coupling and distribution device	SPECIAL	UG-1067/U	Cancelled	
			UG-1068/U	Cancelled	
UG-1041A/U	3.36	REB49289	UG-1069/U	Cancelled	
UG-1042/U	8.20	AS-2063	UG-1070/U	8.20	BENDIX
UG-1043/U	8.20	AS-2065	UG-1071/U	8.20	BENDIX
UG-1044/U	8.20	AS-2061	UG-1072/U	8.20	BENDIX
UG-1045/U	8.20	AS-2074	UG-1073A/U	3.54	REB49215
UG-1046/U	8.20	AS-2068	UG-1074A/U	3.54	REB49216
UG-1047/U	3.25	PRD	UG-1075C/U	3.54	REB49166
UG-1048/U	3.25	PRD	UG-1076C/U	3.54	REB49167
UG-1049/U	3.25	PRD	UG-1077/U	8.20	AS-2062
UG-1050/U	3.67	REB49376	UG-1078/U	8.20	AS-2040
UG-1051/U	3.67	IPC	UG-1079/U	3.43	REB49284
UG-1052/U	3.46	IPC	UG-1080/U	3.43	REB49286
UG-1053/U	9.2	HEWLETT-PACKARD	UG-1081/U	Waveguide flange connects magnetron to CG-850/U	RCA
UG-1054/U	9.2	do	UG-1082/U	3.29	AF53C29638
UG-1055/U	3.29	SC-D-107575	UG-1083A/U	16.5	REB49258
UG-1056/U	3.29	SC-D-107574	UG-1084/U	3.51	AIRTRON
UG-1057/U	3.62	MIL-C-3655/6	UG-1085/U	3.51	AIRTRON
UG-1058/U	3.62	MIL-C-3655/7	UG-1086/U	3.51	AIRTRON
UG-1059/U	3.62	MIL-C-3655/8	UG-1087/U	7.7	REB49267
UG-1060A/U	3.62	MIL-C-3655/9			

^{1/}For latest revisions of drawings, see Section 17.

MIL-HDBK-216
4 January 1962

NOMENCLATURE INDEX - Cont'd

SERVICE TYPE	PAGE NUMBER OR DESCRIPTION	DOCUMENTATION/	SERVICE TYPE	PAGE NUMBER OR DESCRIPTION	DOCUMENTATION/
UG-1088/U	8.20	GEN. COM.	UG-1111/U	3.55	REB49262
UG-1089/U	8.20	GEN. COM.	UG-1115/U	11.2	ANDREW CORP.
UG-1090/U	3.29	ALLEN DuPONT CO.	UG-1116/U	11.2	ANDREW CORP.
UG-1091/U	Connects probe output to UG-21B/U	KINGS	UG-1117/U	11.2	ANDREW CORP.
UG-1092/U	Adapts crystal socket to UG-88/U	KINGS	UG-1118/U	11.2	ANDREW CORP.
UG-1094A/U	3.29	MS35179	UG-1119/U	3.25	ANDREW CORP.
UG-1095B/U	3.46	REB49213	UG-1120/U	3.25	ANDREW CORP.
UG-1096/U	Special Flange		UG-1121/U	3.25	ANDREW CORP.
UG-1097/U	Pressure proof waveguide flange. Used with RG-163/U	CWS	UG-1122/U	3.25	ANDREW CORP.
UG-1098A/U	3.29	MS35178	UG-1123/U	3.14	ANDREW CORP.
UG-1099/U	5.20	ITS	UG-1124/U	3.14	ANDREW CORP.
UG-1100/U	Test adapter; Part of Signal Generator TS-452C/U	LEWYT CORP.	UG-1125/U	3.14	ANDREW CORP.
UG-1101/U	16.5	REB49214	UG-1126/U	3.67	FTL
UG-1102/U	3.35	REB49232	UG-1127()/GPA -27	Test adapter	
UG-1103/U	3.36	REB40233	UG-1130/U	16.5	REB49354
UG-1104/U	3.30	SC-C-86185 or AF54B8567	UG-1131/U	Special adapter	TELRAD
UG-1105/U	Classified	NOT AVAILABLE	UG-1132/U	3.55	REB49305
UG-1106/U	Classified	NOT AVAILABLE	UG-1133/U	3.54	REB49316
UG-1107/U	3.22	DIAMOND	UG-1134/U	3.55	REB49307
UG-1108/U	3.22	DIAMOND	UG-1135/U	3.55	REB49308
UG-1109/U	3.36	DIAMOND	UG-1136/U	3.22	MIL-A-27434 /28
UG-1110/U	3.50	SC-C-105837 or REB49346	UG-1137/U	3.22	MIL-A-27434 /29
			UG-1138/U	3.33	REB49272
			UG-1139/U	Waveguide adapter	
			UG-1140/U	7.7	BENDIX
			UG-1141/U	3.50	SQUARE ROOT MFG. CO.

^{1/}For latest revisions of drawings, see Section 17.

MIL-HDBK-216
4 January 1962

NOMENCLATURE INDEX - Cont'd

SERVICE TYPE	PAGE NUMBER OR DESCRIPTION	DOCUMENTATION ^{1/}	SERVICE TYPE	PAGE NUMBER OR DESCRIPTION	DOCUMENTATION ^{1/}
UG-1142/U	3.22	MIL-A-27434/30	UG-1168/U	3.22	REB49410
UG-1143/U	3.22	MIL-A-27434/21	UG-1169/U	3.67	RW47F199
UG-1144/U	3.22	MIL-A-27434/22	UG-1170/U	3.69	REC49357
UG-1145/U	3.55	REB49322	UG-1171/ALT-6	Classified	NOT AVAILABLE
UG-1146/U	3.22	MIL-A-27434/23	UG-1172/ALT-6	Classified	NOT AVAILABLE
UG-1147B/U	Replaced by MX-2326/U		UG-1173/U	3.55	REB49024
UG-1148/U	3.36	COLLINS	UG-1174/U	3.30	REB49027
UG-1149/U	3.46	SC-C-51118	UG-1179/U	3.79	SC-C-24456
UG-1150/U	3.46	SC-C-51117	UG-1180/U	3.55	REB49026
UG-1151/U	9.2	SL-DL-51748	UG-1181/GR	Special adapter	MOTOROLA
UG-1152/U	9.2	SL-DL-51760	UG-1182/GR	Special adapter	MOTOROLA
UG-1153/U	9.2	SL-DL-51745	UG-1183/GR	Special adapter	MOTOROLA
UG-1154/U	3.25	SC-C-33655	UG-1184/UPM-16	Cancelled	
UG-1155/U	3.25	SC-C-33614	UG-1185A/U	3.46	REB49035
UG-1156/U	11.2	SC-C-33644	UG-1186A/U	3.46	REB49036
UG-1157/U	11.2	SC-B-33589	UG-1187A/U	3.46	REB49037
UG-1158/U	11.2	SC-B-33592	UG-1188/U	3.25	REB49303
UG-1159/U	11.2	SC-B-33596	UG-1189/U	3.39	SC-C-32978
UG-1160/U	11.2 - 3.26	SC-C-33650	UG-1190/U	3.33	SC-C-32986
UG-1161/U	11.2	SC-B-33640	UG-1191/GPS-4	Special	BENDIX
UG-1162/U	11.2	SC-D-33621	UG-1192/U	16.5	REC49034
UG-1163/U	11.2	SC-B-33610	UG-1193/FPS-19	Special adapter	RAYTHEON
UG-1164/U	11.2	SC-B-33628	UG-1194/FPS-19	Waveguide seal	RAYTHEON
UG-1165/U	3.54	REC49347	UG-1195/U	3.46	REB49353
UG-1166/U	3.22	MIL-D-26708	UG-1196/U	7.7	MS90045
UG-1167/U	3.22	MIL-D-26708	UG-1197/U	7.7	MS90044
			UG-1198/U	7.7	MS90047
			UG-1199/U	7.7	MS90046
			UG-1200/U	7.7	MS90049

^{1/}For latest revisions of drawings, see Section 17.

MIL-EDBK-216
4 January 1962

NOMENCLATURE INDEX - Cont'd

SERVICE TYPE	PAGE NUMBER OR DESCRIPTION	DOCUMENTATION ^{1/}	SERVICE TYPE	PAGE NUMBER OR DESCRIPTION	DOCUMENTATION ^{1/}
UG-1201/U	7.7	MS90048	UG-1225/TPS-1D	Flange, waveguide, special	RAYTHEON
UG-1202/U	7.7	MS90061	UG-1226/U	Adapter, special	COMM. PRODS. CO.
UG-1203/U	7.7	MS90060	UG-1227/U	Adapter, special	do
UG-1204/U	7.7	MS90059	UG-1228/U	Adapter, special	do
UG-1205/U	7.7	MS90058	UG-1229/U	Adapter, special	do
UG-1206/U	7.7	MS90063	UG-1230/U	Adapter, special	do
UG-1207/U	7.7	MS90062	UG-1231/U	Adapter, special	do
UG-1208/U	7.7	MS90056	UG-1232/U	Adapter, special	do
UG-1209/U	7.7	MS90054	UG-1233/U	Seal, special	do
UG-1210/U	3.55	REC49355	UG-1234/U	Seal, special	do
UG-1211/U	Special receptacle	NEMS-CLARK	UG-1235/U	Seal, special	do
UG-1212/U	Special plug	NEMS-CLARK	UG-1236/U	Clamp, special	do
UG-1213/U	3.36	REB49364	UG-1237/U	Clamp, special	do
UG-1214/U	3.36	REB49363	UG-1238/U	Clamp, special	do
UG-1215/U	3.36	REB49365	UG-1239/UPM-84	Adapter, special	POLARAD
UG-1216/U	Waveguide adapter	FR MACHINE WORKS	UG-1240/UPM-84	Adapter, special	POLARAD
UG-1217/U	Special adapter	FR MACHINE WORKS	UG-1241/UPM-84	Special adapter	POLARAD
UG-1218/U	9.3	FR MACHINE WORKS	UG-1242/UPM-84	Special adapter	POLARAD
UG-1219/U	9.3	FR MACHINE WORKS	UG-1243/U	Replaced by MX-2327/U	
UG-1220/U	Waveguide adapter	FR MACHINE WORKS	UG-1244/U	16.5	REB49318
UG-1221/U	3.55	REB49349	UG-1245/U	Special	HEWLETT-PACKARD
UG-1222/U	Adapter, special	BOONTON RAD. CORP.	UG-1246/U	Special adapter	HEWLETT-PACKARD
UG-1223/TPS-1D	Adapter, special	RAYTHEON	UG-1247/U	Special adapter	HEWLETT-PACKARD
UG-1224/TPS-1D	Adapter, special	RAYTHEON	UG-1248/U	Special adapter	HEWLETT-PACKARD

^{1/}For latest revisions of drawings, see Section 17.

MIL-HDBK-216
4 January 1962

NOMENCLATURE INDEX - Cont'd

SERVICE TYPE	PAGE NUMBER OR DESCRIPTION	DOCUMENTATION ¹	SERVICE TYPE	PAGE NUMBER OR DESCRIPTION	DOCUMENTATION ¹
UG-1249/U	3.54	HEB49038	UG-1278/U	3.55	HEB49390
UG-1250/U	3.22		UG-1279/U	3.54	HEB49399
UG-1251/U	3.25	ES-DL-161463	UG-1280/FRA-39	Special adapter	WECO
UG-1252/U	Special adapter	RAYTHEON	UG-1281/U	3.47	COMM. PROD.CO
UG-1253/U	3.62	SC-DL-130446	UG-1282/U	3.47	do
UG-1254/U	3.67	SC-DL-34988	UG-1283/U	3.47	do
UG-1255/U	3.67	SC-DL-35042	UG-1284/U	3.47	do
UG-1256/U	3.67	SC-DL-35037	UG-1285/U	3.47	do
UG-1257/U	3.68	SC-DL-35004	UG-1286/U	3.47	do
UG-1258/U	3.39	SC-C-26753	UG-1287/U	3.22	KINGS ELEC.
UG-1259/U	3.68	SC-DL-35032	UG-1288/U	3.22	HEWLETT- PACKARD
UG-1260/U	3.22	SC-DL-35027	UG-1289/U	9.3	HEWLETT- PACKARD
UG-1262/U	3.68	SC-DL-35055	UG-1290/U	9.3	HEWLETT- PACKARD
UG-1263/U	3.68	SC-DL-35050	UG-1291/U	3.52	SC-D-292777
UG-1264/U	3.40	TA-MAR	UG-1292/U	3.52	SC-D-292838
UG-1265/U	3.40	ES-DL-166756	UG-1293/U	3.52	SC-D-292843
UG-1266/U	3.46	ES-DL-166763	UG-1294/U	3.52	SC-D-292869
UG-1267/U	3.46	ES-DL-166749	UG-1295/U	3.52	SC-D-292748
UG-1268/U	3.46	ES-DL-166759	UG-1296/U	3.52	SC-D-292701
UG-1269/U	3.46	ES-DL-166812	UG-1297/U	3.52	SC-D-292722
UG-1270/U	3.46	ES-DL-166724	UG-1298/U	3.52	SC-D-292808
UG-1271/U	3.46	ES-DL-166742	UG-1299/FPS-7	Special adapter	GE
UG-1272/U	3.46	ES-DL-166732	UG-1301/U	3.52	FED. TELE. COMM.LABS.
UG-1273/U	3.47	ES-DL-166746	UG-1302/U	3.52	FED. TELE. COMM.LABS.
UG-1274/U	3.25	ES-DL-161076	UG-1303/U	3.52	FED. TELE. COMM.LABS.
UG-1275/U	3.54	HEB49039			
UG-1276/U	3.55	HEB49348			
UG-1277/GKA	Special adapter	GE			

¹For latest revisions of drawings, see Section 17.

MIL-HDBK-216
4 January 1962

NOMENCLATURE INDEX - Cont'd

SERVICE TYPE	PAGE NUMBER OR DESCRIPTION	DOCUMENTATION ¹	SERVICE TYPE	PAGE NUMBER OR DESCRIPTION	DOCUMENTATION ¹
UG-1304/U	3.52	FED. TELE. COMM. LABS.	UG-1329/U	3.68	RE49B747
UG-1305/U	3.40	TAMAR INC.	UG-1330/U	3.68	PRODELIN INC.
UG-1306/U	3.23	SC-DL-45984	UG-1331/U	3.47	RE49B745
UG-1307/U	3.68	RE49B736	UG-1332/U	3.68	RE49B754
UG-1308/AP	3.47	HAZELTINE A-30235	UG-1333/U	3.68	RE49B749
UG-1309/AP	3.47	HAZELTINE A-30237	UG-1334/U	3.68	RE49B750
UG-1310/UPM-89	Special adapter	HAZELTINE A-31048	UG-1335/U	3.68	RE49B751
UG-1311/U			UG-1336/U	3.68	RE49B752
UG-1312/U	Special adapter	RADIO ENG. PROD F27950	UG-1337/U	3.68	RE49B755
UG-1313/U	Rotary Coupler		UG-1338/URM-104	Waveguide adapter	BOGART B17020
UG-1314/U	3.40	AMPHENOL 82-117	UG-1339/URM-104	Waveguide adapter	BOGART B17019
UG-1315/U	Special adapter	PITOMETER LOG CORP.	UG-1340/USM-68	Special adapter	BRUND N.Y. IND. CORP.
UG-1316/U	3.55	RE49398	UG-1341/FPS-30	Special adapter	BENDIX R650875
UG-1317/FPS-35	Special adapter	HAZELTINE	UG-1342/URM-125	Test adapter	RADIOPLANE 101048-9
UG-1318/U	3.55		UG-1343/U		RE49C735-2
UG-1319/			UG-1344/U		RE49C735-3
UG-1320/U	3.36		UG-1345/U		RE49C735-4
UG-1321/U	3.30 - 3.68		UG-1346/U		RE49C735-5
UG-1322/GRM-20	Test adapter	GB7320179G1	UG-1347/U		RE49C735-7
UG-1323/U	Waveguide adapter	WAVELINE, INC.	UG-1348/U		RE49C735-7
UG-1324/U	3.68	RE49B758	UG-1349/U		RE49C735-8
UG-1325/U	3.68	RE49B757	UG-1350/U		RE49C735-9
UG-1326/U	3.68	RE49B756	UG-1351/U		RE49C735-10
UG-1327/U	3.39	RE49B753	UG-1352/U		RE49C735-11
UG-1328/U	3.47	RE49B748	UG-1353/U		RE49C735-12
			UG-1354/U		RE49C735-13

¹ For latest revisions of drawings, see Section 17.

MIL-HDBK-216
4 January 1962

NOMENCLATURE INDEX - Cont'd

SERVICE TYPE	PAGE NUMBER OR DESCRIPTION	DOCUMENTATION/	SERVICE TYPE	PAGE NUMBER OR DESCRIPTION	DOCUMENTATION/
UG-1355/U		HB49C735-14	UG-1381/U	3.68	AMPHENOL 89-7051
UG-1356/U		HB49C735-15	UG-1382/FPS-26	Special Adapter	AVCo
UG-1357/U		HB49C735-16	UG-1383/FPS-50	Special Adapter	ANDREW CORP.
UG-1358/U		HB49C735-17	UG-1384/FPS-50	Special Adapter	D.S.KENNEDY CORP.
UG-1359/U		HB49C735-18	UG-1385/FPS-50	Special Adapter	ITE
UG-1360/U		HB49C735-19	UG-1386/FPS-6	Special Adapter	GE
UG-1361/U		HB49C735-20	UG-1387/U	Cancelled	
UG-1362/U		HB49C735-1	UG-1388/GFM-44	Test Adapter	ADMIRAL CORP P-AR258
UG-1363/U	16.5	HEB49405	UG-1389/U	Special Adapter	HEWLETT- PACKARD
UG-1364/U	3.61	SIG C TECH REQ 6021	UG-1390/FPS-26	Special Adapter	AVCo
UG-1365/U	3.61	do	UG-1391/FPS-26	Special Adapter	AVCo
UG-1366/U	3.61	do	UG-1392/U	3.56	SIG C TECH REQ 6022
UG-1367/U	3.61	do	UG-1393/U	3.56	do
UG-1368/U	3.23	do	UG-1394/U	3.56	do
UG-1369/U	3.61	do	UG-1395/U	3.56	do
UG-1370/U	3.40	HEB49409	UG-1396/U	3.56	do
UG-1371/U			UG-1397/U	3.56	do
UG-1372/U	3.56	SIG C TECH REQ 6022	UG-1398/U	3.56	do
UG-1373/U	3.56	do	UG-1399/U	3.56	do
UG-1374/U	3.56	do	UG-1400/U	3.51	
UG-1375/U	3.23	do	UG-1401/FPS-26	Special Adapter	AVCo 749729
UG-1376/U	Special Adapter	HAZELTINE	UG-1402/U	Special Adapter	WECO
UG-1377/U			UG-1403/PRC-10	Special Adapter	BURGESS BATTERY MF4244I or MF4244H
UG-1378A/FPS	Special Adapter	BENDIX N658216-1	UG-1404/U	Navy Hull Filling	HEC49412
UG-1379/U	3.51	CANNON ELEC. 039849-000			
UG-1380/U	3.68	AMPHENOL 89-7050			

^{1/}For latest revisions of drawings, see Section 17.

NIL-HDBK-216
4 January 1962

Navy or Signal Corps type	Drawing	Engineering data
NT49188 PL-295	-----	Assigned nomenclature UG-1060/U
NT49189 PL-305	-----	Assigned nomenclature UG-1059/U
NT49190 PL-259	RE49F175	UHF plug: For use with RG-8, 9, 10, 11, 12, 13, 63, and 65/U RF cables.
NT49191 PL-258	RE49F169	Similar to UG-299/U
NT49192A M-359A	RE49F168	Similar to UG-297/U
NT49193 M-360	RE49F167	Assigned nomenclature UG-106/U
NT49194 SO-239	REB49252	Similar to UG-296/U
NT49195 PL-259A		UHF plug: For use with RG-8, 9, 10, 11, 12, 13, 63, and 65/U RF cables.
NT49196 SO-265	-----	Assigned nomenclature UG-1057/U
NT49197	RE49F176	Adapter: For use with cables RG-8, 9, and 10/U. Connects to 7/8 in. 50 ohm line
NT49198 PL-325	-----	Assigned nomenclature UG-1058/U
NT49199 M-358	RE49F172	Similar to UG-298/U
NT49205	RE49F180	Replaced by UG-21D/U
NT49206	RE49F180	Replaced by UG-22D/U
NT49208 M-365	RE49F173	Hood: For use with cables RG-34/U
NT49261	RE49F187	Assigned nomenclature UG-32/U
NT49263	RE49F187	Assigned nomenclature UG-33/U
NT49267	-----	Replaced by UG-27C/U
NT49268	-----	Replaced by UG-21D/U
NT49269	-----	Replaced by UG-22D/U
NT49270	RE49F189	Assigned nomenclature UG-275/U
NT49284	-----	Replaced by UG-21D/U
NT49285	-----	Replaced by UG-22D/U
NT49286	-----	Replaced by UG-18C/U
NT49287	-----	Replaced by UG-19C/U
NT49288	RE49F180	Replaced by UG-18C/U
NT49289	RE49F180	Replaced by UG-19C/U
NT49296	RE49F180	Replaced by UG-23D/U
NT49297	RE49F180	Replaced by UG-18C/U

Navy or Signal Corps type	Drawing	Engineering data
NT49298	-----	Replaced by UG-23D/U
NT49299	-----	Replaced by UG-20C/U
NT49426	RE49F180	Replaced by UG-18C/U
NT49427	RE49F180	Replaced by UG-19C/U
NT49428	RE49F180	Replaced by UG-20C/U
NT49445	-----	Replaced by UG-23D/U
NT49450	RE49F465	Replaced by UG-28A/U
NT49454	RE49F194	Assigned nomenclature UG-31/U
NT49470	-----	Replaced by UG-58A/U
NT49482	RE49F471	Assigned nomenclature UG-203/U
NT49483	RE49F315	Replaced by UG-167D/U
NT49529	RE49F236	Assigned nomenclature UG-192/U
NT49530	RE49F237	End Seal: For use with cables RG-8, 9, and 11/U
NT49531	RE49F227	Assigned nomenclature UG-234/U
NT49532	RE49F227	Assigned nomenclature UG-233/U
NT49544	RE49F242	Assigned nomenclature UG-197/U
NT49547	RE49F251	Assigned nomenclature UG-171/U
NT49533	RE49F255	Adapter: For use with RG-17, 18/U cables.
NT49577	RE49F274	Adapter: For use with RG-17, and 18/U RF cables
NT49599	RE49F448	Assigned nomenclature UG-245/U
NT49601	-----	Assigned nomenclature UG-246/U
NT491049 PL-274	SC-D-6234	Similar to UG-300/U
PL-275	SC-D-10097	Adapter: Twin, small, Nonweatherproof
PL-276	-----	Adapter, bulkhead: Twin, large, nonweatherproof
PL-284	-----	Assigned nomenclature UG-102/U
PL-285	-----	Assigned nomenclature UG-105/U
PL-293	-----	Assigned nomenclature UG-104/U
SO-264	-----	Assigned nomenclature UG-103/U
258-8143	REB49392	Contact End for UG-988/U
295-6291	REB49395	Contact End for UG-665E/U
336-0440	REB49393	Contact End for UG-640D/U
660-6764	REB49394	Contact End for UG-1083A/U
683-1518	REB49391	Terminal for MX-1203F/U

NOTICE OF
CANCELLATION

NOT MEASUREMENT
SENSITIVE

MIL-HDBK-216
NOTICE 11
6 September 2001

MILITARY HANDBOOK
R. F. TRANSMISSION LINES AND FITTINGS

MIL-HDBK-216, dated 4 January 1962, is hereby canceled without replacement.

CONCLUDING MATERIAL

Custodians:

Army – CR
Navy – EC
Air Force – 11
DLA – CC

Preparing activity:
DLA - CC

(Project MISC-0272)

Review activities:

Army – AR, CR4, MI
Navy – AS, MC, OS, SH
Air Force - 99