

INCH-POUND

MIL-STD-47187(MI)
10 August 1993
SUPERSEDING
MIL-N-47187B (MI)
31 August 1990

MILITARY STANDARD

NUTS, BLIND, PRESS,
AND BLIND RIVET,
INSTALLATION OF



AMSC N/A
DISTRIBUTION STATEMENT A.
distribution is unlimited.

AREA 14GP
Approved for public release;

MIL-STD-47187

FOREWORD

1. This military standard is approved for use by the U.S. Army Missile Command, Department of the Army, and is available for use by all Departments and Agencies of the Department of Defense.
2. Beneficial comments (recommendations, additions, deletions) and any pertinent data which may be of use in improving this document should be addressed to: Commander, U.S. Army Missile Command, ATTN: AMSMI-RD-SE-TD-ST, Redstone Arsenal, AL 35898-5270 by using the Standardization Document Improvement Proposal (DD Form 1426) appearing at the end of this document or by letter.

MIL-STD-47187

CONTENTS

<u>PARAGRAPH</u>	<u>PAGE</u>
1.	SCOPE.....1
1.1	Scope.....1
2.	APPLICABLE DOCUMENTS.....2
2.1	Government documents.....2
2.1.1	Specifications, standards, and handbooks.....2
2.2	Non-Government publications.....2
2.3	Order of precedence.....3
3.	DEFINITIONS.....4
3.1	Anchor, sleeve.....4
3.2	Fasteners, threaded.....4
3.3	Lock washers.....4
4.	GENERAL REQUIREMENTS.....5
4.1	Hole preparation.....5
4.2	Installation preparation.....5
4.3	Installation of blind nuts.....5
4.3.1	Installation force.....5
4.4	Workmanship.....7
5.	DETAILED REQUIREMENTS.....8
5.1	Hole size and configuration for blind nut.....8
5.2	Installation of press nuts.....9
5.3	Installation of blind rivet nuts.....10
5.3.1	Head-to-parent material contact.....10
5.3.2	Bulge and tightness.....10
5.3.3	Hole size and configuration for blind rivet nut..10
5.3.4	Replacement of blind rivet nuts.....11
6.	NOTES.....13
6.1	Intended Use.....13
6.2	Issue of DODISS.....13
6.3	Metrication.....13
6.4	Subject term (keyword) listing.....13

MIL-STD-47187

<u>PARAGRAPH</u>		<u>PAGE</u>
FIGURES		
1	Blind nut components and installation.....	5
2	Blind nut installation tool.....	6
3	Blind nut hole configuration.....	8
4	Press nut installation.....	9
5	Blind rivet nut installation.....	10
6	Blind rivet nut hole configuration.....	11
TABLES		
I	Blind nut installation pull force.....	6
II	Blind nut installation hole requirements.....	8
III	Press nut installation hole requirements.....	9
IV	Blind rivet nut installation hole requirements.....	12

MIL-STD-47187

1. SCOPE

1.1 Scope. This standard covers the requirements for the installation of blind nuts, press nuts, and blind rivet nuts.

MIL-STD-47187

2. APPLICABLE DOCUMENTS

2.1 Government documents.

2.1.1 Specifications, standards, and handbooks. The following specifications, standards, and handbooks form a part of this document to the extent specified herein. Unless otherwise specified, the issues of these documents are those listed in the issue of the Department of Defense Index of Specifications and Standards (DODISS) and supplement thereto, cited in the solicitation (see 6.2).

SPECIFICATIONS

FEDERAL

TT-P-1757 - Primer Coating, Zinc Chromate, Low-Moisture-Sensitivity

(Unless otherwise indicated, copies of the federal and military specifications, standards, and handbooks are available from the Standardization Documents Order Desk, Bldg. 4D, 700 Robbins Ave., Philadelphia, PA 19111-5094.)

2.2 Non-Government publications. The following documents form a part of this document to the extent specified herein. Unless otherwise specified, the issues of the documents which are DoD adopted are those listed in the issue of the DODISS cited in the solicitation. Unless otherwise specified, the issues of documents not listed in the DODISS are the issues of the documents cited in the solicitation (see 6.2).

2-1033 - HI-Shear Blind Nut Data Book

(Application for copies should be addressed to Hi-Shear Industries, Inc., 2600-T Skypark Drive, Torrance, CA 90509.)

(Non-Government standards and other publications are normally available from the organizations that prepare or distribute the documents. These documents also may be available in or through libraries or other informational services.)

MIL-STD-47187

2.3 Order of precedence. In the event of a conflict between the text of this document and the references cited herein, the text of this document takes precedence. Nothing in this document, however, supersedes applicable laws and regulations unless a specific exemption has been obtained.

MIL-STD-47187

3. DEFINITIONS

3.1 Anchor, sleeve. A tubular piece, as of metal, fitting over the anchor to make it secure.

3.2 Fastener, threaded. A threaded device used to connect, link, clinch, or bind the rivet or other part in place.

3.3 Lock washers. A flat thin ring or a perforated plate used in joints or assemblies to insure tightness and prevent slippage.

MIL-STD-47187

4. GENERAL REQUIREMENTS

4.1 Hole preparation. Holes shall be straight and perpendicular to the parent material and shall conform to the dimensional requirements specified on the engineering drawing and herein.

4.2 Installation preparation. All surface treatments such as anodize or chemical film treat shall have been completed on the parent material prior to installation. The blind-nut sleeves and press nuts shall be installed with wet zinc chromate primer conforming to TT-P-1757, color Y.

4.3 Installation of blind nuts. Installation of blind nuts shall be as specified in figure 1. Installation shall be such that the sleeve is flush with or not greater than 0.015 inch below the structure surface.

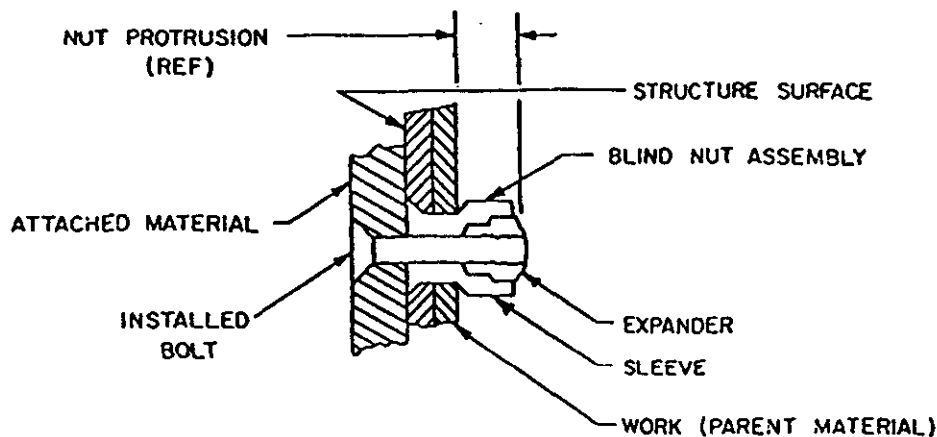
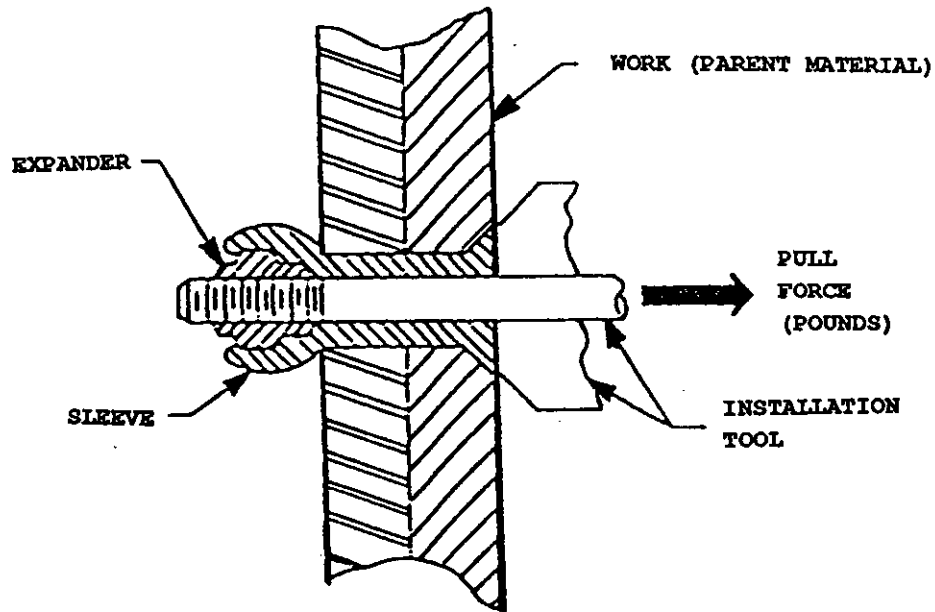

FIGURE 1. Blind nut components and installation.

4.3.1 Installation force. Blind nuts shall be installed as shown in figure 2 by engaging the threads of the expander and pulling the expander into the sleeve with the force specified in table I.

MIL-STD-47187

FIGURE 2. Blind nut installation tool.TABLE I. Blind nut installation pull force.

Thread size	Pull force (pounds) <u>1/</u>
4-40UNC-3B	775-792
6-32UNC-2B	1425-1495
8-32UNC-3B	2550-2680
10-32UNF-3B	3875-4050
1/4-28UNF-3B	6100-6400
5/16-24UNF-3B	8125-8540
3/8-24UNF-3B	9700-10,200
1/2-20UNF-3B	9700-10,200

1/ Installation pull force shall be applied using equipment as specified in HI-Shear Blind Nut Data Chart 2-1033, revised 11 November 1985, HI-Shear Corp., Torrance, California; or equal.

MIL-STD-47187

4.4 Workmanship. Blind nuts, press nuts, and blind rivet nuts shall be uniformly installed and shall reflect a high quality of workmanship.

MIL-STD-47187

5. DETAILED REQUIREMENTS

5.1 Hole size and configuration for blind nut. Hole size shall be as specified in table II. Configuration of the holes shall be as specified in figure 3.

TABLE II. Blind nut installation hole requirements.

Blind nut thread	Hole size D diameter (inch)	Sleeve countersink C diameter (inch) (ref)	
		Shallow head <u>1/</u>	Shearhead <u>2/</u>
4-40UNC-3B	0.170-0.173	0.229	-
6-32UNC-3B	0.219-0.222	0.278	-
8-32UNC-3B	0.258-0.264	0.317	0.395
10-32UNF-3B	0.313-0.319	0.372	0.474
1/4-28UNF-3B	0.391-0.397	0.450	0.560
5/16-24UNF-3B	0.469-0.477	0.528	0.668
3/8-24UNF-3B	0.531-0.539	0.590	0.754
1/2-20UNF-3B	0.656-0.664	0.714	-

1/ Type BN360, HI-Shear Corp., Torrance, California, or equal.

2/ Type BN359, HI-Shear Corp., Torrance, California, or equal.

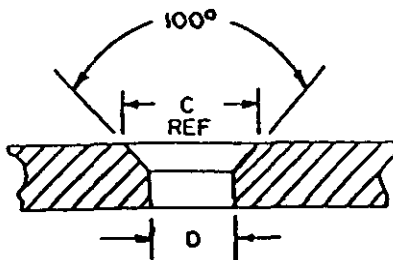

FIGURE 3. Blind nut hole configuration.

MIL-STD-47187

5.2 Installation of press nuts. Installation requirements for press nuts shall be as specified in table III. Press nuts shall be positioned with pilot flange in hole and force shall be applied of sufficient magnitude to cause the flange of the press nut to bear flush against the surface of the parent material (see Figure 4).

TABLE III. Press nut installation hole requirements.

Press nut thread		Hole diameter (inch)
Coarse	Fine	
4-40NC-3B	-	0.172-0.175
6-32NC-3B	-	0.191-0.194
8-32NC-3B	-	0.221-0.224
-	10-32NF-3B	0.250-0.253
-	1/4-28UNF-3B	0.344-0.347
-	5/16-24UNF-3B	0.413-0.418
-	3/8-24UNF-3B	0.484-0.489

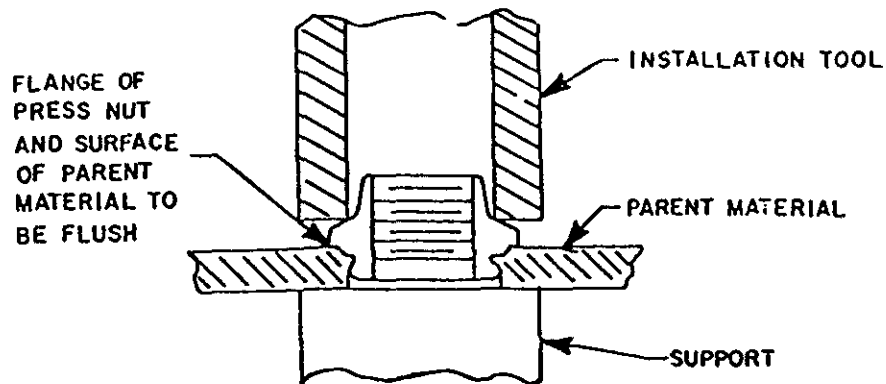

FIGURE 4. Press nut installation.

MIL-STD-47187

5.3 Installation of blind rivet nuts. Installation of blind rivet nuts having countersunk heads or flat heads and keyed or keyless configurations shall be as specified in figure 5. Installation of blind rivet nuts having countersunk heads shall be such that the head is flush with or under flush to the structure surface.

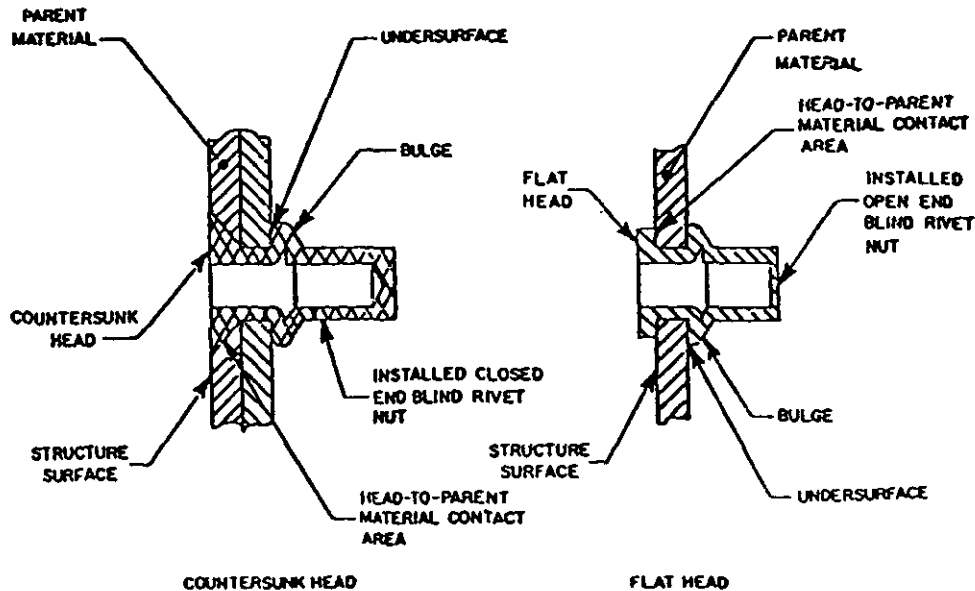

FIGURE 5. Blind nut installation.

5.3.1 Head-to-parent material contact. At least 67 percent of the head-to-parent material contact area (see figure 5) of the blind rivet nut head shall be in contact with the parent material of the structure.

5.3.2 Bulge and tightness. The blind rivet nut shall be firmly secured in the parent material of the structure so there is no relative movement between the installed insert and the structure. The undersurface of the structure (see figure 5) shall be flat so the bulge of the installed blind rivet nut will form normally.

5.3.3 Hole size and configuration for blind rivet nut. Configuration of the holes shall be as specified (see figure 6). When a keyway is required, it shall be cut with a key cutter tool or guided drill. Hole size shall be as specified in table IV.

MIL-STD-47187

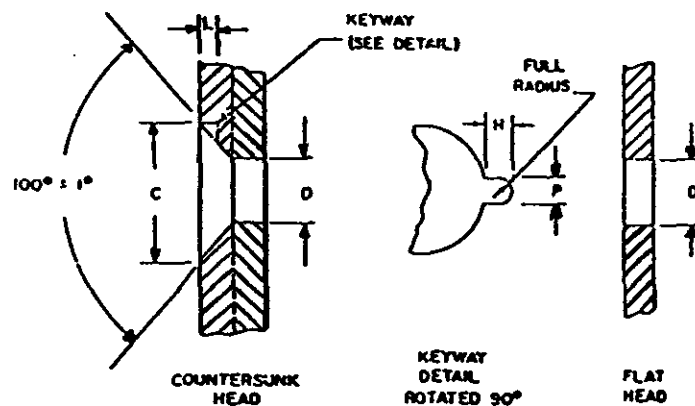

FIGURE 6. Blind rivet hole configuration.

5.3.4 Replacement of blind rivet nuts. Replacement shall be made with the same diameter and configuration, in accordance with the installation procedure of this standard.

TABLE IV. Blind rivet nut installation hole requirements.

Blind rivet nut thread	Hole size D diameter (inch)	Countersink C diameter (inch)	Keyway dimensions		
			Width P (in)	Height H (in)	Length L (in)
4-40UNC-3B	0.155-0.157	0.263	0.062-0.065	0.046-0.048	0.051 min.
6-32UNC-3B	0.189-0.193	0.323	0.062-0.065	0.056-0.058	0.063 min.
8-32UNC-3B	0.221-0.226	0.355	0.062-0.065	0.056-0.058	0.063 min.
10-32UNF-3B	0.250-0.256	0.391	0.062-0.065	0.056-0.058	0.065 min.
1/4-2UNC-3B	0.332-0.338	0.529	0.062-0.065	0.056-0.058	0.089 min.
5/15-18UNC-3B	0.413-0.423	0.656	0.128-0.131	0.097-0.102	0.104 min.
3/8-16UNC-3B	0.490-0.500	0.777	0.128-0.131	0.110-0.115	0.124 min.

MIL-STD-47187

6. NOTES

(This section contains information of a general or explanatory nature that may be helpful, but is not mandatory.)

6.1 Intended use. This standard covers the requirements for the installation of blind nuts, press nuts, and blind rivet nuts.

6.2 Issue of DODISS. When this standard is used in acquisition, the issue of the DODISS to be applicable to this solicitation must be cited in the solicitation (see 2.1.1 and 2.2).

6.3 Metrication. Metric equivalents in accordance with FED-STD-376 are acceptable for use in this standard.

6.4 Subject term (keyword) listing.

Anchor, sleeve
Fasteners, threaded
Lock washers

Custodian:
Army - MI

Preparing activity:
Army - MI

Project 14GP-A127

STANDARDIZATION DOCUMENT IMPROVEMENT PROPOSAL

INSTRUCTIONS

1. The preparing activity must complete blocks 1, 2, 3, and 8. In block 1, both the document number and revision letter should be given.
2. The submitter of this form must complete blocks 4, 5, 6, and 7.
3. The preparing activity must provide a reply within 30 days from receipt of the form.

NOTE: This form may not be used to request copies of documents, nor to request waivers, or clarification of requirements on current contracts. Comments submitted on this form do not constitute or imply authorization to waive any portion of the referenced document(s) or to amend contractual requirements.

I RECOMMEND A CHANGE:	1. DOCUMENT NUMBER MIL-STD-47187	2. DOCUMENT DATE (YYMMDD) 930810
------------------------------	-------------------------------------	-------------------------------------

3. DOCUMENT TITLE

NUTS, BLIND, PRESS, AND BLIND RIVET, INSTALLATION OF

4. NATURE OF CHANGE (Identify paragraph number and include proposed rewrite, if possible. Attach extra sheets as needed.)

5. REASON FOR RECOMMENDATION

6. SUBMITTER

a. NAME (Last, First, Middle Initial)

b. ORGANIZATION

c. ADDRESS (Include Zip Code)

d. TELEPHONE (Include Area Code)

7. DATE SUBMITTED (YYMMDD)

(1) Commercial

(2) AUTOVON
(if applicable)

8. PREPARING ACTIVITY

a. NAME
COMMANDER
U.S. ARMY MISSILE COMMAND

b. TELEPHONE (Include Area Code)

(1) Commercial
(205) 876-6980

(2) AUTOVON
746-6980

c. ADDRESS (Include Zip Code)
ATTN: AMSMI-RD-SE-TD-ST
REDSTONE ARSENAL, AL 35898-5270

IF YOU DO NOT RECEIVE A REPLY WITHIN 45 DAYS, CONTACT:
Defense Quality and Standardization Office
5203 Leesburg Pike, Suite 1403, Falls Church, VA 22041-3466
Telephone (703) 756-2340 AUTOVON 289-2340