

# DAU PROGRAM MANAGERS TOOL KIT

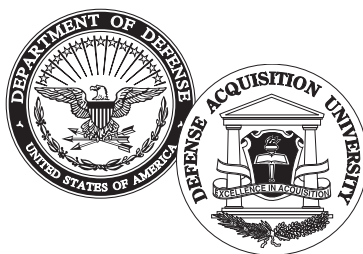

Fourteenth Edition (Ver 2.0)  
April 2008

## DAU PROGRAM MANAGERS TOOL KIT

---

For sale by the  
U.S. Superintendent of Documents, Government Printing Office  
Internet: [bookstore.gpo.gov](http://bookstore.gpo.gov) Phone: 202-512-1800 Fax: 202-512-2250  
Mail Stop: SSOP, Washington, DC 20402-0001

DAU PROGRAM MANAGERS TOOL KIT

## PREFACE

This Fourteenth Edition (Ver 2.0) of the *DAU Program Managers Tool Kit* contains a graphic summary of acquisition policies and managerial skills frequently required by DoD program managers. It is a current version of a “Tool Box” that was first developed by Charles F. Schied of the Defense Acquisition University (DAU) Program Management Course (PMC) 92-1. For convenience, the *Tool Kit* is sized for insertion into a 3-hole, 5-1/2” x 8-1/2” “Day Runner.” The information in the *Tool Kit* is extracted from DAU course material and is based on DoDD 5000.1, DoDI 5000.2, the *Defense Acquisition Guidebook* (DAG), CJCSI 6212.01D (March 14, 2007), and CJCSI 3170.01F (May 1, 2007). Material from the DAU Acker Library and Knowledge Repository was also used.

Since the *DAU Program Managers Tool Kit* is a compilation of classroom presentation and teaching materials used in a number of different courses at DAU, the charts and tables vary in look and feel.

Users of the *Tool Kit* are reminded that this summary is a guide only and should not be used as a substitute for official policy guidance. Periodic review of official policy guidance is recommended.

## DAU PROGRAM MANAGERS TOOL KIT

## ACKNOWLEDGMENTS

As sponsor of the *Tool Kit*, the Learning Capabilities Integration Center (LCIC) recognizes the following members of the DAU staff and faculty for their input to this Fourteenth Edition (Ver 2):

- Bill Bahnmaier, formerly of DAU's Program Management and Leadership Department on the Capital/Northeast Regional Campus, for coordinating the input and editing the material received from various DAU faculty and staff sources.
- Charles Cochrane, formerly the DAU Program Management Center Director, and currently a DoD contractor supporting DAU, for his significant contributions on current DoD acquisition policy.
- Mike Dorohovich, a contractor from CSC Corporation supporting DAU, for his contribution on the DAU knowledge sharing systems.
- Duane Tripp for his input on the latest international acquisition policy and guidance.
- The Learning Capabilities Integration Center and its Center Directors and Performance Learning Directors, including Sharon Jackson, John Morrell, David Bachman, Leslie Deneault, John Krieger, Bill Kobren, John Claxton, John Snoderly, George Prosnik, Bruce Moler, and Bill Motley.
- The Visual Arts and Press Department, including Kathryn Sondheimer for layout/graphics, Judith Greig and Carol Scheina for editing, and Frances Battle for liaison with the Government Printing Office and the commercial printer.

Other significant contributors from the DAU faculty were John Kelley and Bob Daugherty of the Program Management Department; Robert Carlson, Bob Gustavus, Gerry Land, and Miriam Cohe of the Business, Cost Estimating, and Financial Management Department; and Larry Heller of the Logistics Management Department.



Randy Fowler  
Director, Learning Capabilities  
Integration Center

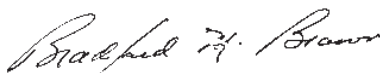

Bradford Brown  
Director, Center for  
Acquisition Management

## DAU PROGRAM MANAGERS TOOL KIT

## TABLE OF CONTENTS

Preface.....	iii
Acknowledgments .....	v
Table of Contents.....	vii
<b>CHAPTER 1—ACQUISITION MANAGEMENT</b> .....	1
The Program Manager’s Bill of Rights and Responsibilities .....	2
Defense Acquisition Decision Points and Phases .....	3
Acquisition Categories (ACAT) .....	4
Acquisition Strategy Considerations.....	5
Acquisition, Technology and Logistics (AT&L) Knowledge	
Management System .....	6–8
Acquisition, Technology, and Logistics Sharing System (AKSS) .....	6
Acquisition Community Connection (ACC) .....	6
<i>Defense Acquisition Guidebook</i> (DAG) .....	7
Integrated Framework Chart (IFC) .....	7
AT&L ACQUIRE .....	8
Best Practices Clearinghouse (BPCh).....	8
Process Performance and Learning Tools.....	8
Defense Acquisition Board Timeline Milestones B, C, and FRPDR.....	9
Milestone Decision Information—A Possible Construct.....	9
Information For Milestone/Decision Reviews .....	10
Interoperability.....	11
S&T Linkage to Defense Acquisition Process.....	12
Joint Capabilities Technology Demonstration (JCTD)	
10-Step Life-Cycle Process Flow.....	13
Acquisition Program vs. ATD and JCTD.....	14
Program Structure/Schedule (Example) .....	15
<b>INTERNATIONAL</b> .....	16–17
DoD International Armaments Cooperation Policy .....	16
The Scope of Defense Cooperation.....	16
Defense Sales vs. Cooperative Acquisition.....	17
International Activities Associated with Defense Acquisition Phases.....	17
<b>FUNDS MANAGEMENT</b> .....	18–31
Resource Allocation Process—Overlap.....	18
Planning, Programming, Budgeting, and Execution (PPBE)—	
Planning Phase.....	19
PPBE—On-Year Program/Budget Review (Even Year) .....	19
PPBE—Off-Year Program/Budget Review (Odd Year) .....	20
Resource Allocation Process .....	20
Congressional Enactment Timetable .....	21
Procurement Appropriations.....	22–23
RD&TE Appropriations (Account Numbers) .....	24
RD&TE Appropriations (Relationship Between MFP 6 R&D	
Categories and RDT&E Appropriations Budget Activities).....	24

## DAU PROGRAM MANAGERS TOOL KIT

**CHAPTER 1—ACQUISITION MANAGEMENT (CONTINUED)**

Sample Navy Appropriations and Budget Activities.....	25
Appropriation Life.....	26
Below Threshold Reprogramming Actions.....	26
Life Cycle Cost Composition.....	27
Product Improvements.....	27
Cost Estimating.....	28
Cost Estimating Relationships (CER)—Parametric.....	28
Cost Estimating Requirements.....	29
Program Cost and Schedule Breach Parameters.....	30
Performance Measurement.....	31
<b>CONTRACTING</b> .....	32–36
Contracting—Components of Contract Price.....	32
Types of Contracts .....	32
Contract Type Features.....	33–34
Pre-Solicitation Process.....	35
Post-Solicitation Process .....	35
Other Ways to Buy .....	36
<b>DEFENSE INDUSTRY BUSINESS MANAGEMENT</b> .....	37–43
Contractor Profitability Ratios .....	37
Aerospace/Defense Industry Contractor Profitability Ratios.....	38
Lockheed Martin Corp.—Dupont Formula Analysis (An Example) .....	39
Cash Cycle.....	40
Contractor Financing and Payments.....	40
Direct and Indirect Costs .....	41
Assigning Indirect Costs .....	41
Life Cycle of Indirect Cost Rates .....	42
Contractor's Cost Proposal.....	42
Contractor Business Planning Process Outputs.....	43
<b>LOGISTICS</b> .....	44–50
Life Cycle Logistics .....	44
Principal Life Cycle Logistics (Goals/Objectives).....	44
System Operational Effectiveness (SOE) .....	44
Best Practice: Support Elements.....	45
Support Element Definitions.....	45
Life Cycle Logistics Linkage To Defense Acquisition Process.....	46
Performance-Based Logistics (PBL) .....	47
Performance-Based Logistics (PBL) Tool Kit .....	47
Post-Production Support Decision Process.....	48
Operational Availability.....	48
Life Cycle Sustainment Metrics .....	49
Life Cycle Sustainment Outcome Enablers.....	49
Logistics Management Community of Practice (LOG COP) .....	50
<i>Defense Acquisition Guidebook—Life Cycle Logistics</i> .....	50

**CHAPTER 1—ACQUISITION MANAGEMENT (CONTINUED)**

<b>ORGANIZATION</b> .....	51–52
Program Office Organization Structures (Examples) .....	51–52
“Traditional” or Functional Structure .....	51
“Pure” Product Structure .....	51
Matrix Structure.....	52
Integrated Product Teams .....	52
<b>MANUFACTURING</b> .....	53–58
The Role of Manufacturing in the Acquisition Process .....	53
Common Production Risks That Greatly Impact Cost, Schedule and Performance .....	53
Producibility.....	54–55
Producibility— <i>Defense Acquisition Guidebook, 4.4.6.1 Producibility</i> ...	54
Quality Management Systems.....	55
Key Characteristics and Variation Reduction .....	55–56
Production Readiness Review (PRR) .....	57
Additional Manufacturing Information Sources .....	57
<b>TEST AND EVALUATION</b> .....	58–63
Test and Evaluation (T&E)—Types and Tasks .....	58
Test and Evaluation Nomograph .....	59–60
Modeling and Simulation (M&S) Planning .....	61
Hierarchy of Models and Simulations.....	62
The Evolution of Modeling and Simulation.....	63
<b>PLANNING AND CONTROL TOOLS</b> .....	64–71
Gantt Chart (Example).....	64
Milestone Chart (Example).....	64
Network Schedules.....	65
Network Schedules (Example).....	66
Examples of Network Scheduling Software.....	67
Schedule Development.....	68
Lead Time Chart.....	69
Line of Balance Technique.....	70
Acquisition Program Baseline.....	71
<b>RISK MANAGEMENT</b> .....	72–75
Risk Management Process Model .....	72
Root Cause Analysis .....	72
Risk Management Process—Details .....	73
Risk and Tradeoffs Analysis.....	74
Program Manager’s Checklist for Review of Tradeoff Planning and Studies.....	75
Technical Performance Measurement .....	75

## DAU PROGRAM MANAGERS TOOL KIT

**CHAPTER 1—ACQUISITION MANAGEMENT (CONTINUED)**

<b>SYSTEMS ENGINEERING</b> .....	76–94
What Is Systems Engineering? .....	76
Systems Engineering Tasks .....	76
Systems Engineering Policy in DoD.....	76
Systems Engineering Process—Technical Management Processes ..	77
Systems Engineering Process Linkages.....	78
Defense Acquisition Management Framework—	
Technical “V” Activities .....	79
Concept Refinement Phase Systems Engineering Activities .....	80
Technology Development Phase Systems	
Engineering (SE) Activities .....	80
System Development and Demonstration Phase SE Activities.....	81
Production and Deployment Phase Systems Engineering Activities.....	81
Operations and Support Phase Systems Engineering Activities .....	82
Requirements (User Needs) Analysis Questions .....	83
Attributes of a Well-Defined Requirement.....	83
Systems Engineering Process—Design Operations .....	84
Systems Engineering Design Considerations—“The Fishbone” .....	85
Technical Management Processes .....	86
Specification Development and Technical Reviews .....	87
Technical Review Definitions .....	88
Technical Review Best Practices.....	89
Specifications and Standards.....	90
Performance vs. Detail Specifications .....	90
Program-Unique Specifications.....	91
Configuration Management .....	92
Interface Management.....	93
Interface Control Concept.....	93
How To Create a Work Breakdown Structure.....	94
Basic Purposes of WBS .....	94
<b>SOFTWARE</b> .....	95–98
Software Development—Technical Review Relationships .....	95
Software Development—Key Life Cycle Review Factors.....	96
Candidate Software Measures (Metrics).....	97
Quality Events For Software .....	97
Software Management Best Practices .....	98
Software Acquisition Worst Practices.....	98
<b>CHAPTER 2—LEADERSHIP AND MANAGERIAL SKILLS</b> .....	99
Management and Leadership.....	100
Empowerment, Delegation, and Coaching .....	101–102
Coaching Skills .....	102
Generic IPT Process .....	103
Formula for Effective Team Performance .....	104

**CHAPTER 2—LEADERSHIP AND MANAGERIAL SKILLS (CONTINUED)**

Team Charter .....	105
Working Groups.....	106–107
Team Development Wheel.....	106
Typical Working Groups .....	106
Management Tradeoffs for Working Groups.....	107
Team Performance Model.....	107
Team Decision Making .....	108
Effective Meetings.....	109
Decision Briefing.....	110
Communications .....	111–113
Counseling .....	113
Time Management.....	114
Management Tools and Techniques.....	115–116

**CHAPTER 3—PROBLEM-SOLVING TOOLS..... 117**

Brainstorming.....	117–118
Cause-and-Effect Diagram .....	119
Force Field Analysis .....	119
Histogram .....	120
Scatter Diagram .....	120
Surveys .....	121
Affinity Diagram.....	122
Affinity Diagram (Example).....	123
Pairwise Ranking .....	124–125
Pairwise Ranking (Example) .....	125
Pareto Chart.....	126
Benchmarking.....	127
Flowcharting .....	128
Standard Flowchart Symbols .....	129
Deployment Flowcharts.....	129–130
Nominal Group Technique (NGT).....	131–132
Creative Problem Solving .....	133
Knot Chart.....	134
Qualitative Problem Solving.....	135
Gantt Chart .....	136

## DAU PROGRAM MANAGERS TOOL KIT

## CHAPTER 1 ACQUISITION MANAGEMENT

- Things that make you go “Hmmm?...”

“The only thing most auditors fix is the blame.”

“Experience is something you got just after you needed it.”

“People are smarter than they look; listen to them.”

“The last 10 percent of the performance sought generates one-third of the cost and two-thirds of the problems.”

“Never open a can of worms unless you want to go fishing.”

“Those who believe it cannot be done, will you please get out of the way of those who are busy doing it?”

- Things we should always remember.

“Be honest in everything you say, write, and do.”

“Be good to your people, and they will be good to you.”

“Forgiveness is easier to obtain than permission.”

“Keep everyone informed; when in doubt, coordinate.”

“Be the first to deliver bad news.”

“Bad news does not get any better with time.”

“If you are sitting at your desk, you are not managing your program.”

DAU PROGRAM MANAGERS TOOL KIT

## **THE PROGRAM MANAGER'S BILL OF RIGHTS AND RESPONSIBILITIES**

### ***RIGHTS:***

Program Managers have the RIGHT to:

- a single, clear line of authority from the Defense Acquisition Executive;
- authority commensurate with their responsibilities;
- timely senior leadership decisions;
- be candid and forthcoming without fear of personal consequences;
- speak for their program and have their judgments respected;
- receive the best available training and experience for the job; and
- be given adequate financial and personnel resources.

### ***RESPONSIBILITIES:***

Program Managers have the RESPONSIBILITY to:

- accept program direction from acquisition executives and implement it expeditiously and conscientiously;
- manage their programs to the best of their abilities within approved resources;
- be customer-focused and provide the user with the best, most cost-effective systems or capabilities;
- innovate, strive for optimal solutions, seek better ways to manage, and provide lessons-learned to those who follow;
- be candid about program status, including risks and problems as well as potential solutions and likely outcomes;
- prepare thorough estimates of financial and personnel resources that will be required to manage the program; and
- identify weaknesses in the acquisition process and propose solutions.

# DEFENSE ACQUISITION DECISION POINTS AND PHASES (DoDI 5000.2)

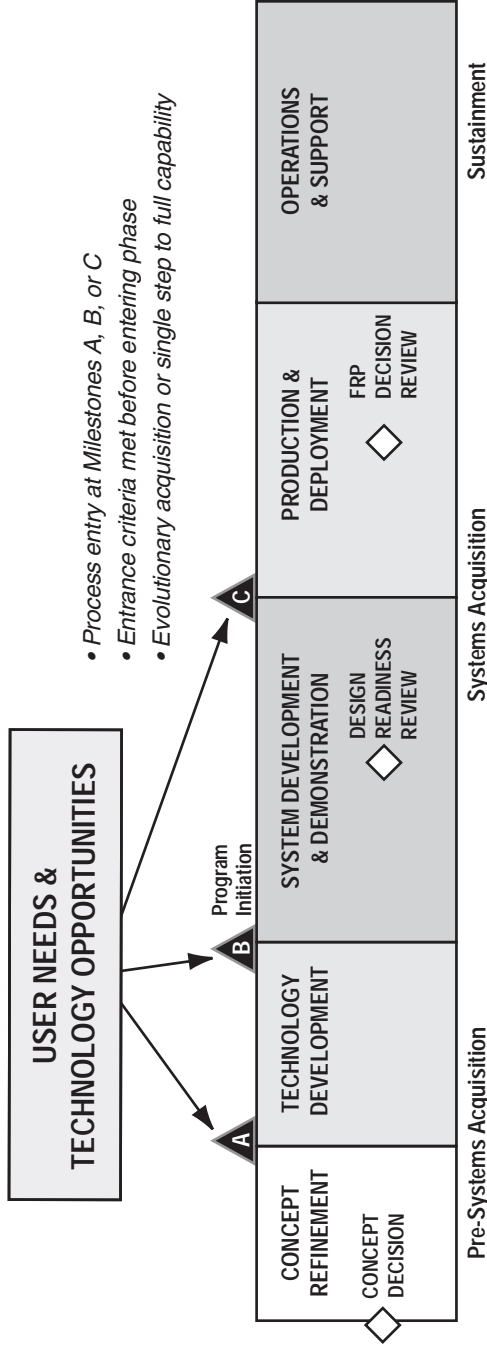

- Process entry at Milestones A, B, or C
- Entrance criteria met before entering phase
- Evolutionary acquisition or single step to full capability

## DAU PROGRAM MANAGERS TOOL KIT

**ACQUISITION CATEGORIES (ACAT)**

<b>Major Defense Acquisition Programs</b>	<b>ACAT ID:</b>	DAB Review Designated by DAE Decision by DAE	\$365M RDT&E or \$2.190B Procurement (FY 00 Constant \$)
	<b>ACAT IC:</b>	Component Review Designated by DAE Decision by Service Sec/CAE	
<b>Major AIS Acquisition Programs</b>	<b>ACAT IAM:</b>	ITAB Review* Designated by ASD(NII)** Decision by ASD(NII)	\$378M Life Cycle Cost or \$126M Total Program Cost or \$32M Program Cost in any single year (FY 00 Constant \$)
	<b>ACAT IAC:</b>	Component Review Designated by ASD(NII) Decision made by Svc Sec/CAE	
<b>Major Systems</b>	<b>ACAT II:</b>	Does Not Meet ACAT I Criteria Designated by Svc Sec/CAE Decision by Svc Sec/CAE	\$140M RDT&E or \$660M Procurement (FY 00 Constant \$)
<b>All Others</b> (except Navy and USMC)	<b>ACAT III:</b>	Does Not Meet ACAT I, IA, or II Criteria Designated IAW Component Policy Decision at lowest appropriate level	No Fiscal Criteria
<b>Navy USMC</b>	<b>ACAT IV:</b>	Not otherwise designated ACAT I, IA, II, or III Designated IAW Component Policy Navy/USMC ACAT IVT/IVM Decision at lowest appropriate level	SECNAVINST 5000.2_

\* Information Technology Acquisition Board

\*\* ASD for Networks and Information Integration (NII); formerly ASD(C3I)

## ACQUISITION STRATEGY CONSIDERATIONS

(*Defense Acquisition Guidebook*, Chapter 2)

- Program Structure
  - Acquisition Approach
  - Capability Needs
  - Test and Evaluation
  - Risk Management
  - Resource Management
    - Funding Under an Evolutionary Acquisition Strategy
    - Advance Procurement
  - Systems Engineering Plan
  - Interoperability
    - Information Interoperability
    - Other than Information Interoperability
  - Information Technology
  - Research and Technology Protection
    - Protection of Critical Information
    - Anti-Tamper Measures
  - Information Assurance
  - Product Support Strategy
  - Human Systems Integration
  - Environmental Safety and Occupational Health
  - Modular Open Systems Approach
  - Business Considerations
    - Competition
      - ◆ Fostering a Competitive Environment
        - Competition Advocates
        - Ensuring Future Competition for Defense Products
      - ◆ Building Competition into Individual Acquisition Strategies
        - Applying Competition to Acquisition Phases
        - Applying Competition to Evolutionary Acquisition
        - Competition and Source of Support
        - Industry Involvement
    - ◆ Potential Obstacles to Competition
      - Exclusive Teaming Arrangement
      - Sub-Tier Competition
    - ◆ Potential Sources
      - Market Research
      - Commercial and Nondevelopmental Items
      - Dual-Use Technologies
      - Use of Commercial Plans
      - Industrial Capability
    - ◆ Small Business Innovative Research (SBIR) Technologies
  - International Cooperation
    - ◆ International Cooperative Strategy
    - ◆ International Interoperability
    - ◆ International Cooperation Compliance
    - ◆ Testing Required for Foreign Military Sales
  - Contract Approach
    - ◆ Performance-Based Business Strategy
    - ◆ Modular Contracting
    - ◆ Contract Bundling
    - ◆ Major Contract(s) Planned
    - ◆ Multi-Year Contracting
    - ◆ Contract Type
    - ◆ Contract Incentives
    - ◆ Integrated Contract Performance Management
    - ◆ Special Contract Terms and Conditions
    - ◆ Warranties
    - ◆ Component Breakout
  - Leasing
  - Equipment Valuation
    - ◆ Program Description
    - ◆ Accounting Review
    - ◆ Contract Implications
- Best Practices
- Relief, Exemption, or Waiver
- Additional Acquisition Strategy Topics

**NOTE:** In addition to the Acquisition Strategy, there are five plans required: Acquisition Plan (FAR/DFARS), Program Protection Plan and Test and Evaluation Master Plan (DoDI 5000.2), Information Support Plan (ISP) (CJCSI 6212.01D), and Systems Engineering Plan (USD AT&L Memo February 20, 2004).

## DAU PROGRAM MANAGERS TOOL KIT

# ACQUISITION, TECHNOLOGY AND LOGISTICS (AT&L) KNOWLEDGE MANAGEMENT SYSTEM (Composed of the following systems)

## Acquisition, Technology, and Logistics Knowledge Sharing System (AKSS)



The AKSS portal is the new knowledge repository component of the AT&L Knowledge Management System (AKMS). It is the primary reference tool for the Defense AT&L community, and it provides a central point to access and organize AT&L resources and information. AKSS has a personalized search, sort, and display capability, and it provides a means to link information and reference assets from various disciplines into an integrated information source. The AKSS portal provides direct links to DoD acquisition policies, including USD(AT&L) memoranda, Federal Acquisition Regulation, and Defense Federal Acquisition Regulation Supplement, as well as department and service guidance and instructions. In addition, the AKSS portal is a trusted source of information on acquisition news, Web sites, training opportunities, and other relevant information. To learn more, go to <https://akss.dau.mil> and take the online virtual tour.

**Ask a Professor (AAP)** <https://akss.dau.mil/aap> is a service offered as part of AKSS. Users submit acquisition-related questions and receive formal responses. In addition, the AAP contains a database of questions and answers that are categorized by subject area and can be browsed or searched.

---

## Acquisition Community Connection (ACC)



The ACC is the collaborative component of the AKMS that focuses on acquisition-related topics and disciplines such as contracting, logistics, program management, and risk management. It consists of Communities of Practice, Special Interest Areas, and collaborative workspaces that

- connect people with know-how across DoD organizations and industry;
- enable members to interact and share resources, ideas, and experiences to support job performance and avoid duplication of effort; and
- identify partnership development opportunities.

Members may request workspaces in ACC, which provide a way for physically dispersed individuals to centrally locate and share documents and references as well as manage team projects. To learn more, go to <https://acc.dau.mil> and take the online virtual tour.

## DEFENSE ACQUISITION GUIDEBOOK (DAG)

The DAG <<https://akss.dau.mil/dag>> provides links to policy, law, and useful content housed in communities of practice. It allows users to navigate through the *Guidebook* via a document index, graphical interface (Life Cycle Framework), or a search by topic.

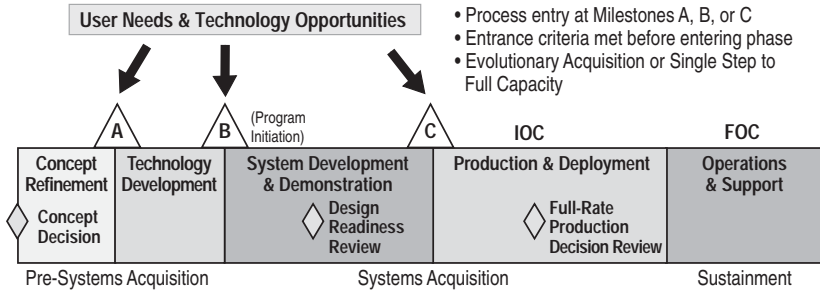

## INTEGRATED FRAMEWORK CHART (IFC)

The AT&L IFC <<https://acc.dau.mil/ifc>> is a pictorial road map of key activities in the systems acquisition process. Users navigate through a graphical model of the three major acquisition process areas: Joint Capabilities Integration and Development System (JCIDS); Defense Acquisition; and Planning, Programming, Budgeting, and Execution (PPB&E).

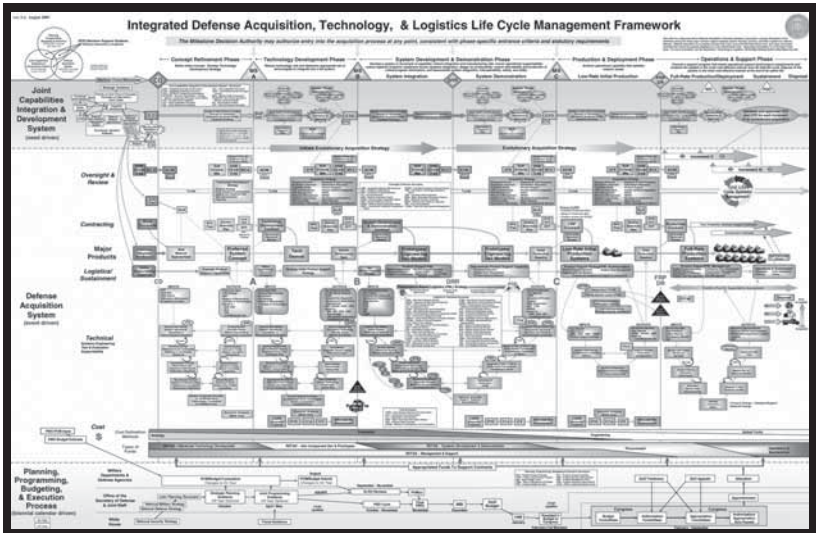

## DAU PROGRAM MANAGERS TOOL KIT

### **AT&L ACQUIRE**

ACQUIRE <<http://acquire.dau.mil>> is a search tool focused on the specific needs of the acquisition workforce. It uses the DAU acquisition taxonomy, trusted acquisition sites, and selected AT&L resources to enhance searches and derive better results. Searches can be conducted by individual or multiple sites; document titles; topic; content, via an index of major categories; and subcategories.

Courseware is also searchable via ACQUIRE. Users can suggest additional AT&L sites that should be included in ACQUIRE crawls.

---

### **BEST PRACTICES CLEARINGHOUSE (BPCh)**

The BPCh is an innovative “clearinghouse” approach that will improve all DoD’s acquisition processes by helping programs select and implement proven practices appropriate to the individual program needs. Initially, the BPCh will focus on software acquisition and systems engineering.

The Clearinghouse provides:

- an authoritative source for practices, lessons learned, and risks to avoid;
- validated practices with consistent, verifiable information;
- an active knowledge base to help with practice questions;
- an intelligent front-end to quickly get to answers;
- useful information and tools to help find, select, and implement practices appropriate to specific programs; and
- living knowledge through a constantly updated, expanded, and refined database.

---

### **PROCESS PERFORMANCE AND LEARNING TOOLS**

Process Performance and Learning Tools (PPLTs) link learning and job support assets to complicated process flow to help users create plans and other AT&L products accurately and efficiently. The following PPLTs have been developed:

- Pricing Support Tool <<http://pricingtool.dau.mil>>
- Performance Based Logistics Toolkit <<https://acc.dau.mil/pbltoolkit>>

## DEFENSE ACQUISITION BOARD TIMELINE MILESTONES B, C, AND FRPDR

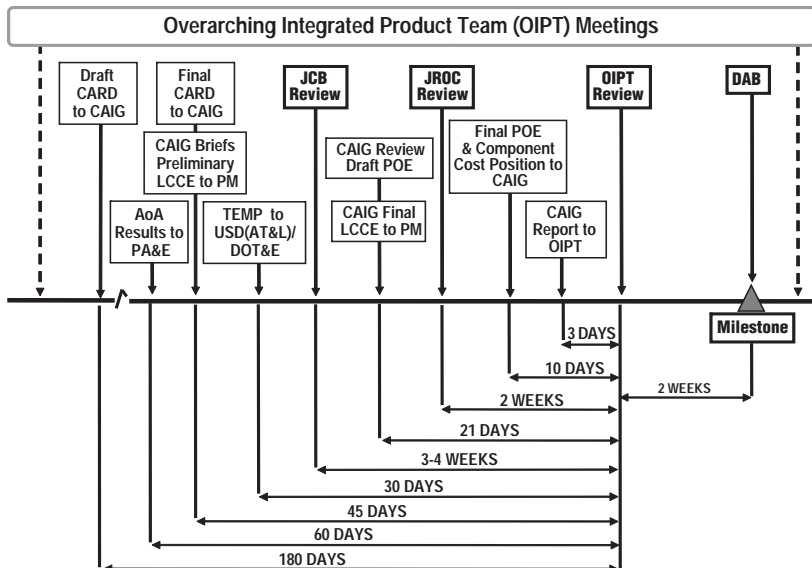

- ADM - Acquisition Decision Memorandum
- CAIG - Cost Analysis Improvements Group
- CARD - Cost Analysis Requirements Description
- DAB - Defense Acquisition Board
- FRPDR - Full Rate Production Decision Review
- JCB - Joint Capabilities Board
- JROC - Joint Requirements Oversight Council
- LCCE - Life Cycle Cost Estimate(s)

### MILESTONE DECISION INFORMATION— A POSSIBLE CONSTRUCT

**1 WHY?**

- Threat
- Capability

**2 WHAT?**

- Requirement
- Analysis of Alternatives

**3 HOW?**

- Acquisition Strategy

**4 RISKS?**

- Risk Mgmt Plan
- T&E Plan
- T&E Results

**5 COST?**

- CAIV Objectives
- LCCE
- ICE

**6 MANAGEMENT?**

- PMO Structure
- IPT Structure
- WIPT—OIPT Structure

**7 AGREEMENT?**

- APB
- ADM
- Exit Criteria

- \* Have I presented all necessary information?
- \* Does the information flow logically?
- \* Is the information clear and accurate?
- \* Is it concise, executive-level information?

## DAU PROGRAM MANAGERS TOOL KIT

## REQUIREMENTS FOR MILESTONE/DECISION REVIEWS

See encl 3, DoDI 5000.02

Requirement	Milestone/Decision Point					
	MDD	A	B	P-CDRA	C	FRP
Acquisition Decision Memorandum <sup>5</sup>	X	X	X	X	X	X
Acquisition Program Baseline <sup>5</sup>			X		X	X
Acquisition Strategy <sup>5</sup> (see Page 5)			X		X	X
Acquisition Information Assurance Strategy (all IT incl NSS)		X	X		X	X
Affordability Assessment			X		X	
Alternate Live Fire T&E Plan (pgms w/waiver from full-up LFT&E) <sup>2</sup>			X			
Analysis of Alternatives (AoA) <sup>3&amp;5</sup>		X	X		X	X
AoA Study Guidance	X					
Benefit Analysis & Determination <sup>1&amp;8</sup> (bundled acquisitions)			X			
Beyond LRIP Report <sup>2</sup> (incl MDAPs that are also MAIS)						X
Capability Development Document (CDD) <sup>5</sup>			X			
Capability Production Document (CPD)					X	
Clinger-Cohen Act (CCA) Compliance <sup>5</sup>		X	X		X	X
Clinger-Cohen Act (CCA) Certification <sup>7</sup>		X	X		X	X
Competition Analysis <sup>1&amp;8</sup> (depot-level maintenance rule)			X			
Component CIO Confirmation of CCA Compliance (non-MAIS IT) <sup>5</sup>		X	X		X	X
Component Cost Estimate <sup>5&amp;9</sup> (MAIS; optional MDAP)		X	X			X
Consideration of Technology Issues (MDAP & MAIS)		X	X		X	
Cooperative Opportunities <sup>1</sup>		X	X		X	
Core Logistics/Source of Repair Analysis <sup>1&amp;8</sup>			X		X	
Corrosion Prevention Control Plan <sup>1</sup>			X		X	
Cost Analysis Requirements Description <sup>5&amp;9</sup> (MDAP & MAIS)			X		X	X
Data Management Strategy <sup>1</sup> (MDAP, MAIS & ACAT II)		X	X		X	X
Economic Analysis (MAIS) <sup>7</sup> (may be combined w/AoA at MS-A)		X	X			X
Exit Criteria <sup>5</sup>		X	X		X	X
Industrial Base Capabilities <sup>1</sup> (MDAPs only))			X		X	
Independent Cost Estimate (ICE) <sup>5&amp;10</sup> (MDAPs only)		X	X		X	X
Independent Technology Readiness Assessment <sup>11</sup>			X		X	
Information Support Plan <sup>1&amp;5</sup>			X	X	X	
Initial Capabilities Document (ICD) <sup>4&amp;5</sup>	X	X	X		X	
Initial Operational Test & Evaluation Completed (ACAT I & II)						X
Item Unique Identification (IUID) Plan (Part of SEP)		X	X		X	
Joint Interoperability Test Certification (IT & NSS)						X
Life-Cycle Signature Support Plan <sup>5</sup>		X	X		X	
Life-Cycle Sustainment Plan <sup>1</sup>			X		X	X
Live Fire T&E Waiver <sup>2</sup> (covered systems) (n/a MAIS)			X			

## DAU PROGRAM MANAGERS TOOL KIT

Requirement	Milestone/Decision Point					
	MDD	A	B	P-CDRA	C	FRP
Live Fire T&E Report <sup>2</sup> (covered systems) (n/a MAIS)						X
LRIP Quantities MDAP & ACAT II (n/a AIS)			X			
Manpower Estimate (MDAPS only) <sup>5</sup>			X		X	X
Market Research		X	X			
Milestone Decision Authority (MDA) Certification (MDAPs only) <sup>4</sup>		X	X		X	
MDA assessment of chem, bio, rad, and nuc survivability			X		X	
Military Equipment Validation <sup>1</sup>					X	X
Net-Centric Data Strategy <sup>5 &amp; 12</sup>		X	X		X	
Operational Test Agency Report of OT&E Results			X		X	X
Preliminary Design Review (PDR) Report			X			
Program Manager's Report of DT&E Results			X		X	
Post-Critical Design Review (CDR) Report				X		
Post Implementation Review						X
Program Protection Plan (PPP) <sup>1</sup>		X	X		X	
Pgm Environ, Safety & Occup Health Evaluation (PESHE) <sup>5</sup>			X		X	X
Replaced System Sustainment Plan <sup>5</sup> (MDAPs only)			X			
Selected Acquisition Report (SAR) <sup>4 &amp; 13</sup>						
Spectrum Supportability Determination <sup>9</sup>			X		X	
System Threat Assessment (STA) (ACAT II) <sup>5 &amp; 14</sup>			X		X	
System Threat Assessment Report (STAR) (ACAT I) <sup>5 &amp; 6</sup>			X		X	
Systems Engineering Plan (SEP)		X	X		X	
Technology Development Strategy (MDAP & MAIS)		X	X		X	
Technology Readiness Assessment (TRA) <sup>5</sup>			X		X	
Test & Evaluation Master Plan (TEMP)			X		X	X
Test & Evaluation Strategy (TES)		X				

<sup>1</sup> Part of TDS or Acquisition Strategy<sup>2</sup> OSD T&E Oversight Programs<sup>3</sup> MDAP: A,B,C; MAIS: A, B, FRP<sup>4</sup> Milestone C if Program Initiation<sup>5</sup> Program Initiation for Ships<sup>6</sup> Validated by DIA for ACAT ID; AIS use DIA validated capstone info/ops Threat Assessment Decision<sup>7</sup> Milestone C if equivalent to FRP<sup>8</sup> Milestone C if no Milestone B<sup>9</sup> MAIS whenever an economic analysis is required<sup>10</sup> May be CAIG Assessment at Milestone A<sup>11</sup> ACAT ID only if required by DDR&E<sup>12</sup> Summarized in TDS; details in ISP<sup>13</sup> SAR at program initiation; annually thereafter<sup>14</sup> Validated by Component; AIS use DIA validated capstone info/ops Threat Assessment Decision

## INTEROPERABILITY

### DoD Policy: DoD Directive 4630.05

Information Technology and National Security Systems employed by U.S. Forces shall, where required (based on capability context), interoperate with existing and planned systems and equipment, of joint, combined, and coalition forces and with other U.S. Government departments and agencies, as appropriate.

### Joint Staff (J-6) Certification and Validation

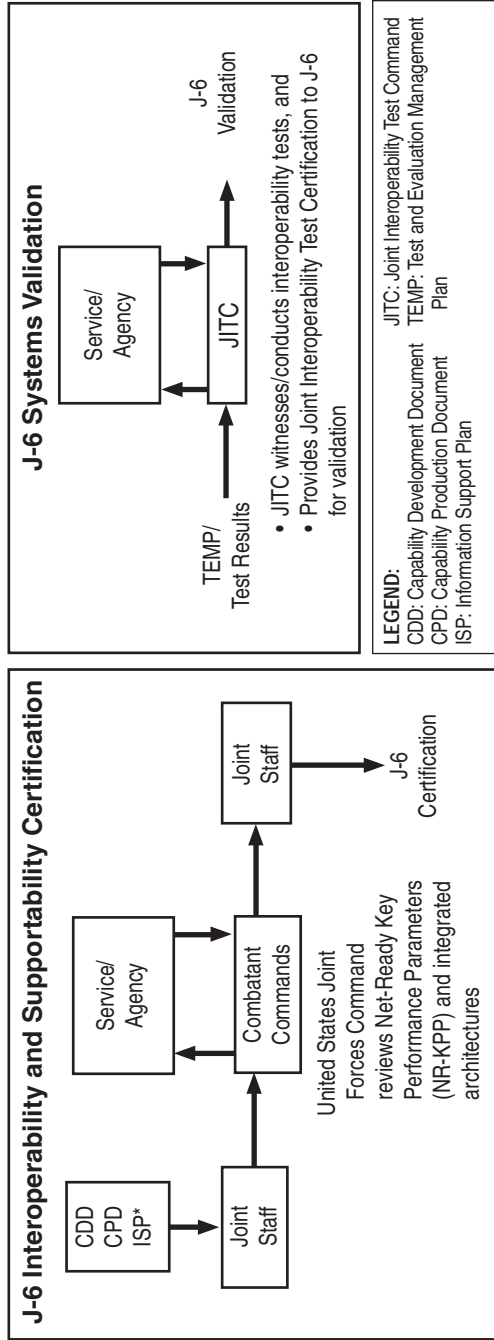

\*NR-KPP certification

DAU PROGRAM MANAGERS TOOL KIT

S&T LINKAGE TO DEFENSE ACQUISITION PROCESS

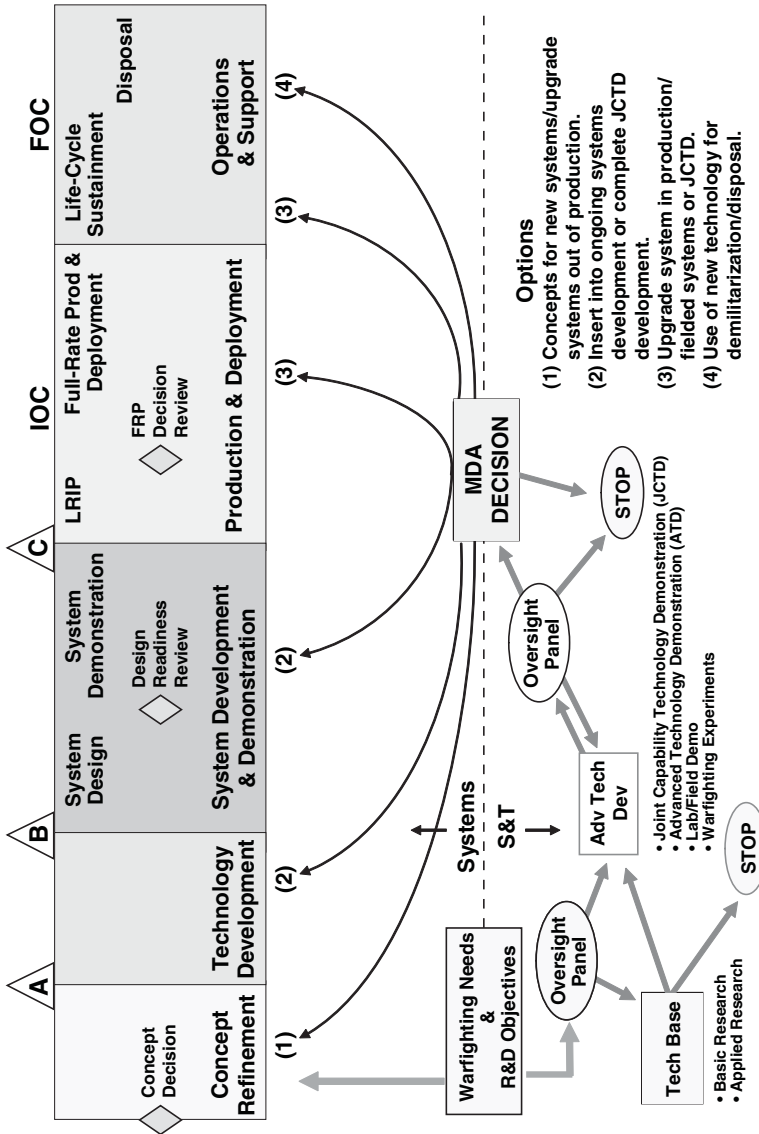

# JOINT CAPABILITIES TECHNOLOGY DEMONSTRATION (JCTD) 10-STEP LIFE-CYCLE PROCESS FLOW

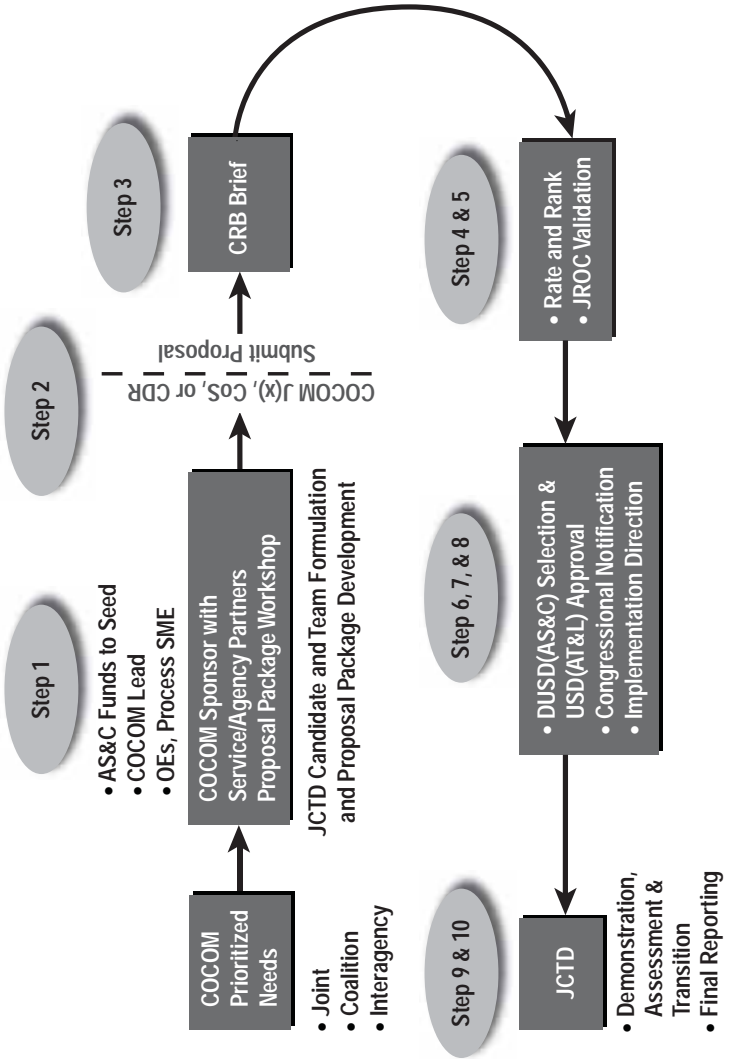

DAU PROGRAM MANAGERS TOOL KIT

**ACQUISITION PROGRAM vs. ATD AND JCTD**

	<b>Acquisition Program</b>	<b>Advanced Technology Demonstration (ATD)</b>	<b>Joint Capability Tech Demonstration (JCTD)</b>
<b>Motivation</b>	<ul style="list-style-type: none"> <li>Develop, produce, and field system</li> <li>Cost, schedule, performance</li> </ul>	<ul style="list-style-type: none"> <li>Demonstrate feasibility and maturity</li> <li>Reduce technical risks and uncertainties at relatively low cost</li> </ul>	<ul style="list-style-type: none"> <li>Gain understanding of and evaluate utility prior to acquisition decision</li> <li>Develop concepts of operation and doctrine</li> </ul>
<b>Documented Need</b>	ICD/CDD/CPD	Not Required	JROC Approval and Prioritization
<b>Oversight</b>	Milestone Decision Authority	Labs/R&D Centers	DUSD(ASC) Oversight Panel
<b>Funding</b>	Fully FYDP Funded	RDT&E	RDT&E (2 years in field)
<b>ACAT</b>	All ACATs	Not ACAT Effort	Not ACAT Effort
<b>Configuration and Testing</b>	System/Subsystem Prototypes DT/OT	Technology Demonstrations	Tech Demonstrations In Field Environment/MUA
<b>Rules</b>	DoD 5000 Series/FAR	Informal/FAR/OTA	Implementation Directive/FAR/OTA
<b>Role of User</b>	Max Involvement	Some Involvement	Max Involvement

<b>LEGEND:</b>	DT/OT—Developmental/Operational Testing	FYDP—Future Years Defense Program
ACAT—Acquisition Category	DUSD(AS&C)—Deputy Under Sec Def	ICD—Initial Capabilities Document
CDD—Capability Development Document	(Advanced Systems and Concepts)	MUA—Military Utility Assessment
CPD—Capability Production Document	FAR—Federal Acquisition Regulation	



## DAU PROGRAM MANAGERS TOOL KIT

## DoD INTERNATIONAL ARMAMENTS COOPERATION POLICY

“PMs shall pursue international armaments cooperation to the maximum extent feasible, consistent with sound business practice and with the overall political, economic, technological, and national security goals of the United States. International agreements for international armaments cooperation programs shall complete the interagency consultation and Congressional notification requirements contained in 10 U.S.C. 2350a, Section 2751 of the Arms Export Control Act, and 10 U.S.C. 2531.”

— DoDD 5000.1 (Para E1.1.1)

### THE SCOPE OF DEFENSE COOPERATION

<u>RDT&amp;E</u>	<u>Production and Procurement</u>	<u>Follow-on Support</u>
Information Exchanges	Foreign Military Sales	Cooperative Logistics Supply Support
Engineer and Scientist Exchanges	Direct Commercial Sales Exchanges	Mutual Support
Cooperative R&D	Cooperative Production (Joint Funds)	Logistics Support
Comparative or Joint Testing	Coproduction/Licensing (Foreign Funds)	Host Nation Support Defense Industrial Base
Standardization	Reciprocal Procurement	



***The Program Manager's Focus***

## DEFENSE SALES vs. COOPERATIVE ACQUISITION

*They are Different*

- |  |   |
|--|---|
| <ul style="list-style-type: none"> <li>• <b>Defense Sales</b> <ul style="list-style-type: none"> <li>– Any Nation</li> <li>– U.S. Contracts (FMS)</li> <li>– U.S. Manages (FMS)</li> <li>– Production and Support</li> <li>– Dept. of State or Dept. of Commerce + DoD                             <ul style="list-style-type: none"> <li>– USD(Policy)</li> </ul> </li> <li>– Foreign Initiated</li> <li>– Foreign Funds (or U.S. Credit/Grants)</li> </ul> </li> </ul> | <ul style="list-style-type: none"> <li>• <b>Cooperative Acquisition</b> <ul style="list-style-type: none"> <li>– Allied or Friendly</li> <li>– U.S., Ally or NATO</li> <li>– Jointly Managed</li> <li>– All Acquisition</li> <li>– DoD – USD(AT&amp;L) + Dept. of State and Dept. of Commerce</li> <li>– U.S. and/or Foreign</li> <li>– Foreign + U.S. Funds</li> </ul> </li> </ul> |
|--|---|

## INTERNATIONAL ACTIVITIES ASSOCIATED WITH DEFENSE ACQUISITION PHASES

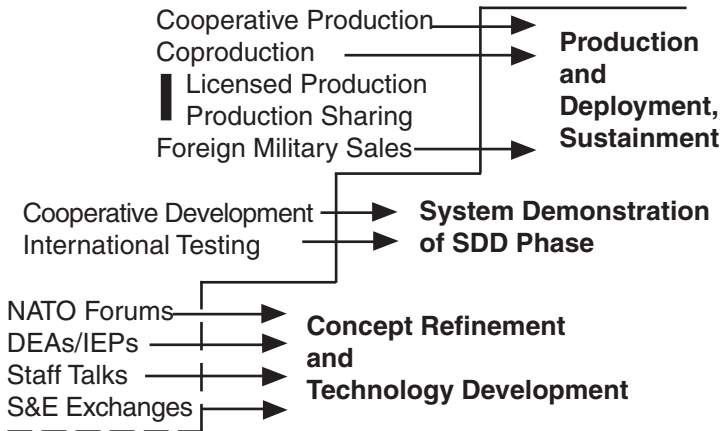

**Technology Opportunities and User Capability Needs**

**Legend:**

- DEA—Data Exchange Agreement
- IEP—Information Exchange Project
- S&E—Science and Engineering

DAU PROGRAM MANAGERS TOOL KIT

**RESOURCE ALLOCATION PROCESS—OVERLAP**

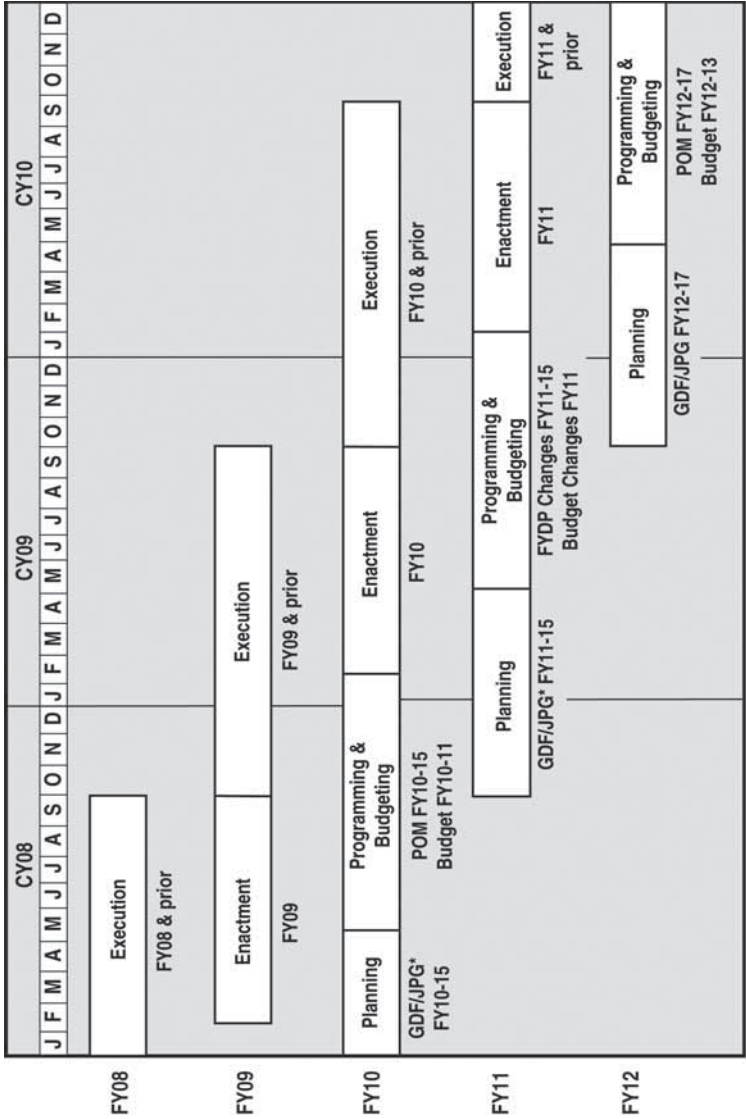

\*GDF SECDEF option in off year

## PLANNING, PROGRAMMING, BUDGETING, AND EXECUTION (PPBE)—PLANNING PHASE

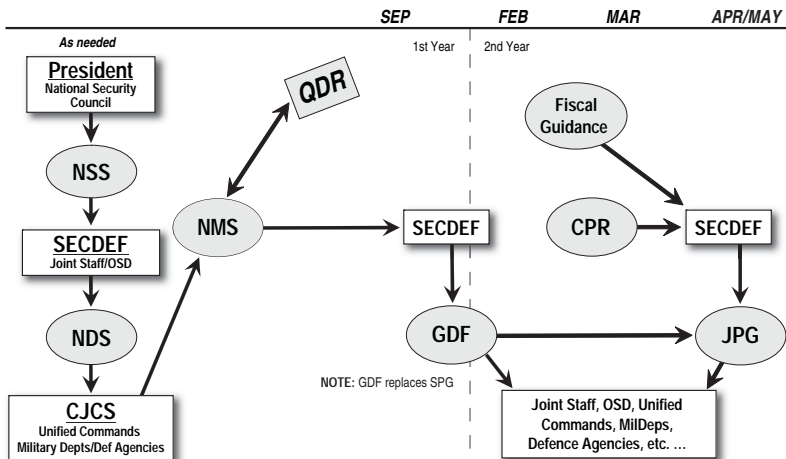

**Legend:**

CJCS—Chairman of the Joint Chiefs of Staff  
 CPR—Chairman's Program Recommendation  
 GDF—Guidance for Development of the Force

JPG—Joint Programming Guidance  
 NMS—National Military Strategy  
 NDS—National Defense Strategy  
 NSS—National Security Strategy  
 QDR—Quadrennial Defense Review

## PPBE—ON-YEAR PROGRAM/BUDGET REVIEW

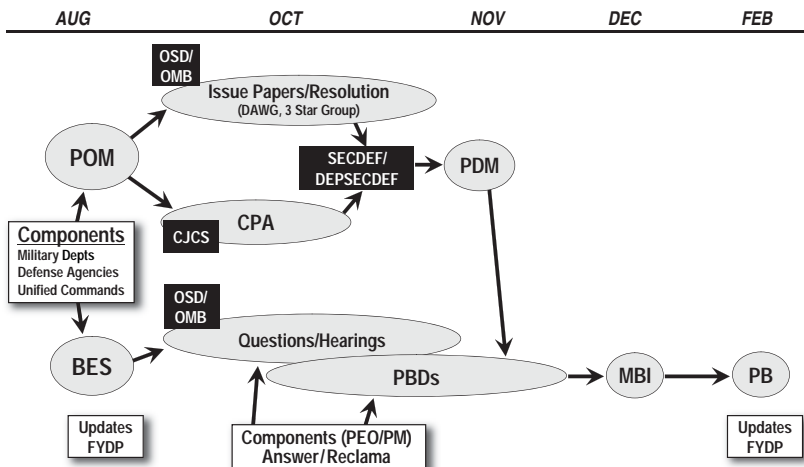

**Legend:**

BES—Budget Estimate Submission  
 COCOM—Combatant Commander  
 CPA—Chairman's Program Assessment  
 DAWG—Deputies Advisory Working Group

FYDP—Future Years Defense Program  
 MBI—Major Budget Issues  
 PB—President's Budget  
 PBD—Program Budget Decision

PEO/PM—Program Executive Officer/  
 Program Manager  
 PDM—Program Decision Memorandum  
 POM—Program Objectives Memorandum

DAU PROGRAM MANAGERS TOOL KIT

**PPBE—OFF-YEAR PROGRAM/BUDGET  
REVIEW (ODD YEAR)**

(e.g., FY 09–13 (Aug 07—Feb 08))

- No Program Objectives Memorandum submissions
- Focus priority on FY 09
- Program of Record (POR) remains FY 08 President’s Budget
- Minimize programmatic changes
- Change Proposal (CP) is vehicle to request changes to POR
- No FYDP update until FY 09 PB
- Complete Budget Estimate Submission provided to the Office of the Undersecretary of Defense (Comptroller) must incorporate all baseline changes
- Program/Budget Review Process
  - 3-Star Group oversees CP review
  - Deputy’s Advisory Working Group considers major issues and advises SECDEF
  - Budget issues reviewed and coordinated through Program Budget Decision (PBD) process
  - SECDEF makes final resource decisions
  - Approved changes and decisions documented in Program Decision Memorandums and PBDs

**RESOURCE ALLOCATION PROCESS**

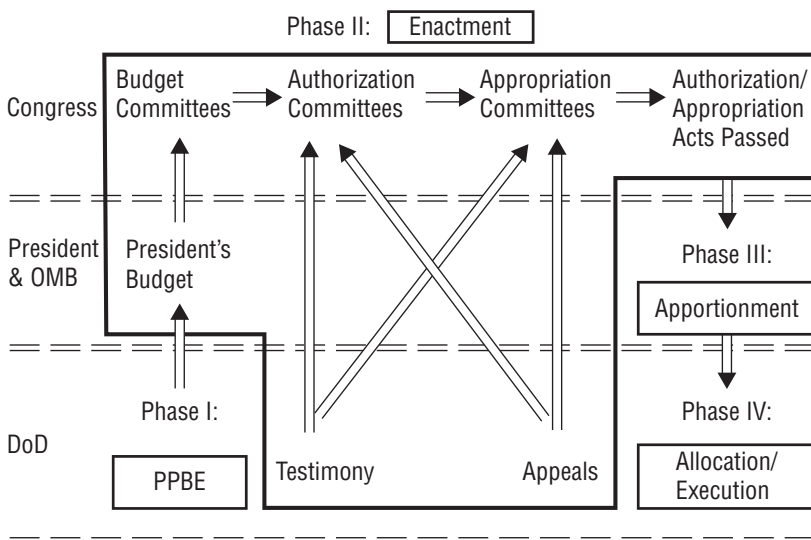

# CONGRESSIONAL ENACTMENT TIMETABLE

	JAN	FEB	MAR	APR	MAY	JUN	JUL	AUG	SEP	OCT
		^		15	15					
	PRES BUDGET									
	COMMITTEE INPUTS									
BUDGET RESOLUTION	HOUSE	<u>HRNGS MARKS FLOOR</u>		<u>FLOOR</u>						
	SENATE	<u>HRNGS MARKS FLOOR</u>	<u>FLOOR</u>	<u>CONF RESOLUTION</u>						
AUTHORIZATION	HOUSE		<u>HASC HRNGS MARKS FLOOR</u>	<u>FLOOR</u>	<u>CONF/ REPT</u>	<u>CONF/ REPT</u>	<u>CONF/ REPT</u>	<u>CONF/ REPT</u>	<u>CONF/ REPT</u>	<u>CONF/ REPT</u>
	SENATE		<u>SASC HRNGS MARKS FLOOR</u>	<u>FLOOR</u>	<u>CONF/ REPT</u>	<u>CONF/ REPT</u>	<u>CONF/ REPT</u>	<u>CONF/ REPT</u>	<u>CONF/ REPT</u>	<u>CONF/ REPT</u>
APPROPRIATION	HOUSE		<u>HAC HRNGS MARKS FLOOR</u>	<u>FLOOR</u>	<u>CONF/ REPT</u>	<u>CONF/ REPT</u>	<u>CONF/ REPT</u>	<u>CONF/ REPT</u>	<u>CONF/ REPT</u>	<u>CONF/ REPT</u>
	SENATE		<u>SAC HRNGS MARKS FLOOR</u>	<u>FLOOR</u>	<u>CONF/ REPT</u>	<u>CONF/ REPT</u>	<u>CONF/ REPT</u>	<u>CONF/ REPT</u>	<u>CONF/ REPT</u>	<u>CONF/ REPT</u>

"TARGET" FISCAL YEAR

## DAU PROGRAM MANAGERS TOOL KIT

## PROCUREMENT APPROPRIATIONS (Account Numbers and Budget Activities)

<i><b>Appropriation</b></i>	<i><b>Budget Activity</b></i>
<b>Army (21 -)</b>	
Aircraft	- 2031 1 Aircraft 2 Modification of Aircraft 3 Spares and Repair Parts 4 Support Equipment and Facilities
Missile	- 2032 1 Not Used 2 Other Missiles 3 Modification of Missiles 4 Spares and Repair Parts 5 Support Equipment and Facilities
Weapons and Tracked Combat Vehicles	- 2033 1 Tracked Combat Vehicles 2 Weapons and Other Combat Vehicles 3 Spares and Repair Parts
Ammo	- 2034 1 Ammo 2 Ammo Production Base Support
Other	- 2035 1 Tactical and Support Vehicle 2 Communications and Electronics 3 Other Support Equipment 4 Initial Spares
<b>Navy (17 -)</b>	
Aircraft	- 1506 1 Combat Aircraft 2 Airlift Aircraft 3 Trainer Aircraft 4 Other Aircraft 5 Modification of Aircraft 6 Aircraft Spares and Repair Parts 7 Aircraft Support Equipment and Facilities
Weapons	- 1507 1 Ballistic Missiles 2 Other Missiles 3 Torpedoes and Related Equipment 4 Other Weapons 5 Not Used 6 Spares and Repair Parts
Ammo, Navy and Marine Corps	- 1508 1 Ammo, Navy 2 Ammo, Marine Corps
Shipbuilding and Conversion	- 1611 1 Not Used 2 Other Warships 3 Amphibious Ships 4 Not Used 5 Auxiliaries, Craft, and Prior-Year Program Costs
Other	- 1810 1 Ships Support Costs 2 Communications and Electronics Equipment 3 Aviation Support Equipment 4 Ordnance Support Equipment 5 Civil Engineering Support Equipment 6 Supply Support Equipment

## DAU PROGRAM MANAGERS TOOL KIT

## PROCUREMENT APPROPRIATIONS (Account Numbers and Budget Activities) (Continued)

<i><b>Appropriation</b></i>	<i><b>Budget Activity</b></i>
Other (continued)	-1810 7 Personnel and Command Support Equipment 8 Spares and Repair Parts
<b><i>Marine Corps (17 -)</i></b>	
Procurement	- 1109 1 Not Used 2 Weapons and Combat Vehicles 3 Guided Missiles and Equipment 4 Communications and Electronics Equipment 5 Support Vehicles 6 Engineering and Other Equipment 7 Spares and Repair Parts
<b><i>Air Force (57 -)</i></b>	
Aircraft	- 3010 1 Combat Aircraft 2 Airlift Aircraft 3 Trainer Aircraft 4 Other Aircraft 5 Modification of In-Service Aircraft 6 Aircraft Spares and Repair Parts 7 Aircraft Support Equipment and Facilities
Missile	- 3020 1 Ballistic Missiles 2 Other Missiles 3 Modification of In-Service Missiles 4 Spares and Repair Parts 5 Other Support
Ammo	- 3011 1 Ammo 2 Weapons
Other	- 3080 1 Not Used 2 Vehicular Equipment 3 Electronics and Telecommunications Equipment 4 Other Base Maintenance and Support Equipment 5 Spares and Repair Parts
<b><i>Defense (97 -)</i></b>	
Defense-wide	- 0300 1 Major Equipment 2 Special Operations Command 3 Chemical/Biological Defense
National Guard and Reserve Equipment	- 0350 1 Reserve Equipment 2 National Guard Equipment
Defense Production Activity Purchase	- 0360 1 Defense Production Activity Purchases
Chemical Agents and Munitions Destruction	- 0390 1 Chemical Agents and Munitions Destruction—O&M 2 Chemical Agents and Munitions Destruction—RDT&E 3 Chemical Agents and Munitions Destruction— Procurement
Rapid Acquisition Fund	-2095 1 Rapid Acquisition Fund

## DAU PROGRAM MANAGERS TOOL KIT

## RDT&E APPROPRIATIONS (Account Numbers)

<u>Appropriation</u>	<u>Account Number</u>
RDT&E, Army	21 - 2040
RDT&E, Navy	17 - 1319
RDT&E, Air Force	57 - 3600
RDT&E, Defense-wide	97 - 0400
Development T&E, Defense	97 - 0450
Operational T&E, Defense	97 - 0460

## RDT&E APPROPRIATIONS Relationship Between MFP 6 R&D Categories and RDT&E Appropriations Budget Activities

<b>MFP 6 R&amp;D Category</b>	<b>RDT&amp;E Budget Activity</b>	<b>RDT&amp;E Budget Activity Title</b>
6.1	BA 1	Basic Research
6.2	BA 2	Applied Research
6.3	BA 3	Advanced Technology Development
6.4	BA 4	Advanced Component Development and Prototypes
6.5	BA 5	System Development and Demonstration
6.6	BA 6	RDT&E Management Support
---	BA 7	Operational System Development

<b>Legend:</b>	RDT&E—Research, Development, Test and Evaluation
BA—Budget Activity	T&E—Test and Evaluation
MPF—Major Force Program	
R&D—Research and Development	

**\*NOTE:** Although similar, titles of the Major Force Program (MFP) six categories (which are not shown above) are not exactly the same as titles of the RDT&E Appropriation Budget Activities. In addition, the "Operational System Development" Budget Activity for RDT&E BA 7 is not considered MFP 6. While correctly funded with RDT&E dollars, these efforts do not fall under a MFP 6 Category; rather, for MFP purposes, the efforts are considered part of the Major Force Program that the fielded operational system falls within.

## DAU PROGRAM MANAGERS TOOL KIT

## SAMPLE NAVY APPROPRIATIONS AND BUDGET ACTIVITIES

MFP 6 R&D Category	RDT&E Budget Activity (BA) Number and Title	Below Threshold Reprogramming Rules Max In*      Max Out*	Years Available For Obligation Purposes	Funding Rate	
		(At Prog. Element Level)			
6.1	BA 1 Basic Research	\$10M**	Lesser of \$10M or 20% of amount appropriated	2	Incremental
6.2	BA 2 Applied Research	↓	↓	↓	↓
6.3	BA 3 Advanced Tech. Development				
6.4	BA 4 Adv. Comp. Dev. and Prototypes				
6.5	BA 5 System Devel. and Demo.				
6.6	BA 6 RDT&E Management Support (T&E Ranges) (Civilian Salaries)				
	BA 7 Operational Systems Devel. (Post-Production)				
Procurement Budget Activity	Budget Activity Description	Below Threshold Reprogramming Rules Max In      Max Out	Years Available for Obligation Purposes	Funding Policy	
		(At Line Item Level)			
<b>PROCUREMENT (Proc.)</b>					
SCN-1	Not Used	\$20M**	Lesser of \$20M or 20% of amount appropriated	5	Full
SCN-2	Ship Conversion—Other Warships	↓	↓	↓	↓
SCN-3	Ship Conversion—Amphibious Ships				
SCN-4	Not Used				
SCN-5	Ship Conversion—Auxiliaries, Craft, and Prior-Year Program Costs				
WPN-1	Weapons Proc.—Ballistic Missiles				
WPN-2	Weapons Proc.—Other Missiles			3	
WPN-3	Weapons Proc.—Torpedos and Equipment			↓	↓
WPN-4	Weapons Proc.—Other Weapons				
WPN-5	Not Used				
WPN-6	Weapons Proc.—Spares and Repair Parts				
OPN-1	Other Proc.—Ship Support Equipment (SE)				
OPN-2	Other Proc.—Comm./Electronics Equip.				
OPN-3	Other Proc.—Aviation SE				
OPN-4	Other Proc.—Ordnance SE				
OPN-5	Other Proc.—Civil Engineering SE				
OPN-6	Other Proc.—Supply SE				
OPN-7	Other Proc.—Pers. and Command SE				
OPN-8	Other Proc.—Spares and Repair Parts				
APN-1	Aircraft Proc.—Combat Aircraft	↓	↓	↓	↓
APN-2	Aircraft Proc.—Airlift Aircraft				
APN-3	Aircraft Proc.—Trainer Aircraft				
APN-4	Aircraft Proc.—Other Aircraft				
APN-5	Aircraft Proc.—Modifications of Aircraft				
APN-6	Aircraft Proc.—Aircraft Spares and Repair Parts				
APN-7	Aircraft Proc.—Aircraft SE and Facilities				
Other Appropriations / Titles		Below Threshold Reprogramming Rules Max In      Max Out	Years Available for Obligation Purposes	Funding Policy	
<b>O&amp;M, N</b>	Operations and Maintenance	\$15M	No Congressional Restriction	1	Annual
<b>MILPER, N</b>	Military Personnel	\$10M	No Congressional Restriction	1	Annual
<b>MILCON, N</b>	Military Construction	Lesser of +\$2.0M or 25% Appropriated	No Congressional Restriction	5	Full

\*Below Threshold Reprogramming (BTR) amount limits are cumulative over entire period of time the specific fiscal year appropriation is available for obligation purposes (i.e., 1, 2, 3, or 5 years).

\*\*Reference Source: USD(C) Memo: Subject: FY 2006 Below Threshold Reprogramming Authority Policy, 10 Feb 2006

## DAU PROGRAM MANAGERS TOOL KIT

## APPROPRIATION LIFE

	YEARS											
	1	2	3	4	5	6	7	8	9	10	11	
O&M	■	■	■	■	■	■	■	■	■	■	■	■
RDT&E	■	■	■	■	■	■	■	■	■	■	■	■
PROCUREMENT	■	■	■	■	■	■	■	■	■	■	■	■
SHIPS	■	■	■	■	■	■	■	■	■	■	■	■
MILCON	■	■	■	■	■	■	■	■	■	■	■	■
MILPERS	■	■	■	■	■	■	■	■	■	■	■	■

■ **Current Period:** Available for new obligations, obligation adjustments, expenditures, and outlays

■ **Expired Period:** Available for obligation adjustments, expenditures, and outlays

■ **Cancelled:** Unavailable for obligations, obligation adjustments, expenditures, and outlays

## BELOW THRESHOLD REPROGRAMMING ACTIONS

Amounts are Cumulative Over Entire Period of  
Obligation Availability

APPN	MAX INTO	MAX OUT	MAX OUT	OBLIGATION AVAILABLE
RDT&E	+\$10M*	Lesser of -\$10M 20%	Lesser of	Line Item
PROC	+\$10M*	Lesser of -\$20M -20%	Line Item	3 Years (Shipbuilding and Conversion: 5 Years)
O&M	+\$15M	None, Unless Otherwise Specified	Budget Activity (BA) Some Ba 1 Sub-activity Limitations On Decreases (Operating Forces)	1 Year
MILPERS	+\$10M	No Specific Congressional Restriction	Budget Activity	1 Year
MILCON	Lesser of +\$2M +25%	No Specific Congressional Restriction	Project	5 Years

\* RDT&E changed to \$10M and Procurement changed to \$20M for FY 03, FY 04, FY 05 per OSD Comptroller.

# LIFE CYCLE COST COMPOSITION

## Life Cycle Cost

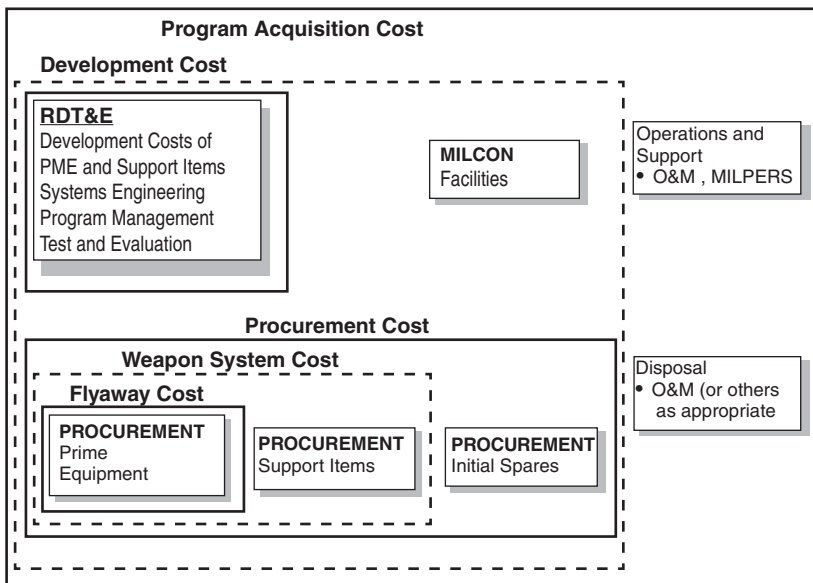

# PRODUCT IMPROVEMENTS

## Funding Decision Tree

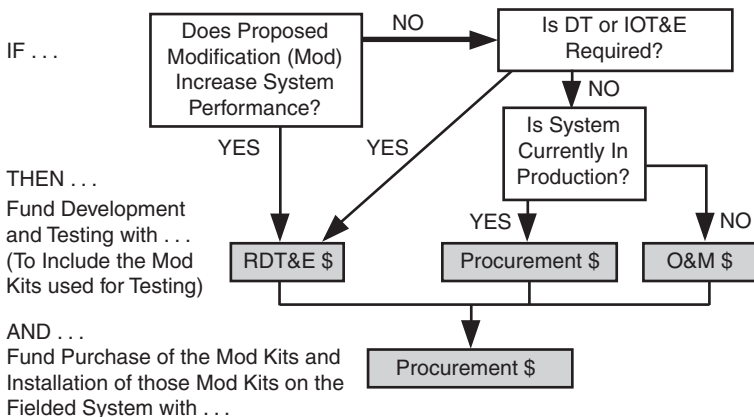

## DAU PROGRAM MANAGERS TOOL KIT

**COST ESTIMATING****Estimate Methods    Comments**

Analogy	Comparison to <i>one</i> similar existing system; based on judgments. Little or no data available; relatively quick, easy, flexible. Used in early phases (e.g., Concept Refinement and Tech. Dev.).
Parametric	Comparison to <i>many</i> similar existing systems; based on statistical analysis. Determine primary cost drivers and establish Cost Estimating Relationships (CERs). Used in early to mid-phases (e.g., Concept Refinement and Tech. Dev., and System Dev. and Dem.).
Engineering or “Bottoms-Up”	Summation of “all” individual items in the system. Uses Work Breakdown Structure (WBS) for estimating purposes. Used in mid-phases (e.g., System Dev. and Dem.).
Extrapolation	Comparison to historical cost of <i>same</i> system. Based on extrapolation from actuals. Uses Learning Curve Theory. Used in late phases (e.g., production and replenishment spares).

**Guidelines**

1. Make sure cost data are relevant and homogeneous. Caution: Watch out for historical data in times of change. Prior actuals may include uncompensated overtime or were priced as a “buy-in.”
2. Focus on cost drivers.
3. Test sensitivities and data relationships.

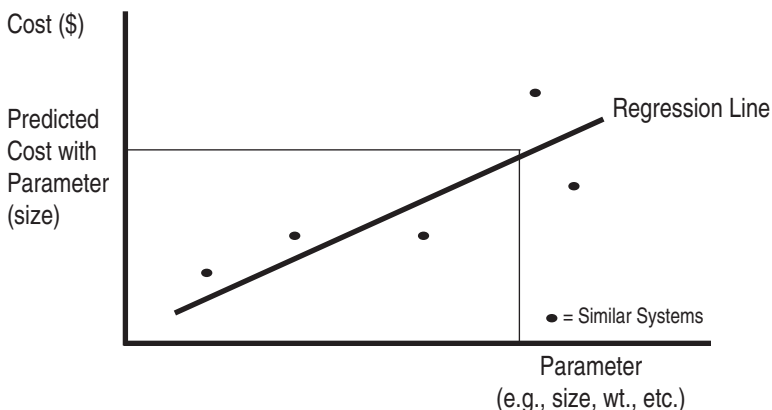
**COST ESTIMATING RELATIONSHIPS  
(CER)—PARAMETRIC**

## COST ESTIMATING REQUIREMENTS

	ACAT IC and ID	ACAT IAM and IAC
POE	Program initiation and all subsequent milestones, including FRP DR	Program initiation and all subsequent milestones <ul style="list-style-type: none"> <li>• Includes Economic Analysis</li> </ul>
CARD	Required same as ICE or CCA <ul style="list-style-type: none"> <li>• Draft 180 days prior to OIPT/milestone</li> <li>• Draft 180 days prior to OIPT/milestone</li> </ul>	Required same as CCA <ul style="list-style-type: none"> <li>• Draft 180 days prior to OIPT/milestone</li> <li>• Final 45 days prior to OIPT/milestone</li> </ul>
CCA	Usually serves as ICE for ACAT IC programs <ul style="list-style-type: none"> <li>• Prepared by component cost agency (AFCAA, DASA-CE, NCCA)</li> <li>• Program initiation and all subsequent milestones including FRP DR</li> <li>• Prepared at MDA discretion for other programs</li> </ul>	Program initiation and whenever economic analysis is required
ICE	Required by law for all MDAP programs * <ul style="list-style-type: none"> <li>• Prepared by OSD CAIG for ACAT ID and ACAT IC at discretion of USD(AT&amp;L)</li> <li>• Program initiation and all subsequent milestones including FRP DR</li> </ul>	

**ACAT II and ACAT III: POE (and CCA and MDA discretion) at program initiation and all subsequent milestones.**

**Legend:**

AFCAA—Air Force Cost Analysis Agency  
 CAIG—Cost Analysis Improvement Group  
 CARD—Cost Analysis Requirements Description  
 CCA—Component Cost Analysis  
 DASA-CE—Dep Asst Sec of Army (Cost and Economics)  
 FRP DR—Full Rate Production Decision Review

ICE—Independent Cost Estimate  
 MDA—Milestone Decision Authority  
 MDAP—Major Defense Acquisition Program  
 NCCA—Naval Center for Cost Analysis  
 OIPT—Overarching Integrated Product Team  
 POE—Program Office Estimate  
 USD(AT&L)—Under Secretary of Defense (Acquisition, Technology, and Logistics)

\*ICE statutory requirement (Title 10, US Code, Sec 2434), Source: DoDI 5000.2

## DAU PROGRAM MANAGERS TOOL KIT

**PROGRAM COST AND SCHEDULE BREACH PARAMETERS**

<b>Applicable to Major Defense Acquisition Programs (MDAPs)</b>			
	<b>SAR</b> <i>(Title 10, US Code, Sec 2432)</i>	<b>Unit Cost Report (UCR)</b> <i>(Title 10, US Code, Sec 2433) (Nunn-McCurdy)</i>	<b>APB</b> <i>(Title 10, US Code, Sec 2435)</i>
<b>Schedule Milestones</b>	6 month slip from previous SAR	N/A	Slip beyond threshold date * Default threshold = objective plus 6 months; MDA discretion
<b>Cost</b>	15/30% PAUC Growth (Current/Original)  15/30% APUC Growth (Current/Original)	15/30% PAUC Growth (Current/Original)  15/30% APUC Growth (Current/Original)	15%/30% PAUC Growth 15%/30% APUC Growth (Current/Original)  * RDT&E Growth * Procurement Growth * MilCon or O&M Growth * 10% default; MDA discretion
<b>Reports Required if Breach Occurs</b>	Quarterly SAR	Quarterly/Exception DAES Service notifies Congress (>15/30%) SecDef Certification (>25/50%)	Program Deviation Report
<b>ACAT II and III: 15%/30% PAUC/APUC APB breach parameters are N/A; actual breach parameters at MDA discretion</b>			
<b>Legend :</b> APUC—Average Procurement Unit Cost PAUC—Program Acquisition Unit Cost DAES—Defense Acquisition Executive Summary		<b>Critical Cost Growth (APB/SAR/UCR)</b> PAUC or APUC increases of 25% of current baseline or 50% of original baseline requires Sec Def certification to Congress: -- Essential to national defense -- No alternatives -- Cost are under control -- Management is in place to keep costs under control	
Significant Cost Growth (APB/SAR/UCR) PAUC or APUC increases of 15% of current baseline or 30% of original baseline is "reportable" to Congress			

## PERFORMANCE MEASUREMENT

### COST AND SCHEDULE PERFORMANCE MEASUREMENT

1. Define the work
  2. Schedule the work
  3. Allocate budgets
- } Cost Account
4. Defining, Planning and Budgeting:

WBS

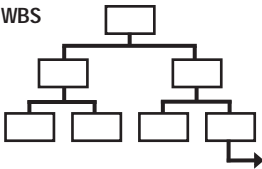

ELEMENT/COST ACCOUNT—300

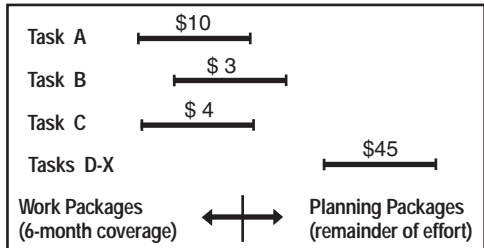

5. Prepare and monitor performance profiles:

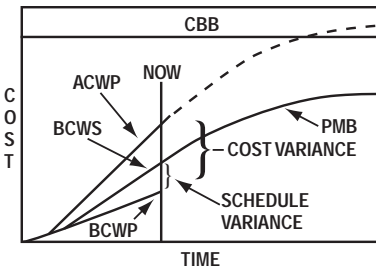

**VARIANCES**

- Cost Variance  $CV = BCWP - ACWP$
- Schedule Variance  $SV = BCWP - BCWS$
- Cost Variance %  $CV\% = \frac{BCWP - ACWP}{BCWP}$
- Schedule Variance %  $SV\% = \frac{BCWP - BCWS}{BCWS}$
- Variance at Completion  $VAC = BAC - EAC$

**PERFORMANCE INDICES**

$$\text{Cost Performance Index } CPI = \frac{BCWP}{ACWP}$$

$$\text{Schedule Performance Index } SPI = \frac{BCWP}{BCWS}$$

$$\text{Percent Complete} = \frac{BCWP_{(cum)}}{BAC}$$

$$\text{Percent Spent} = \frac{ACWP_{(cum)}}{BAC}$$

**ESTIMATE AT COMPLETION**

$$EAC \text{ (Lowest Estimate)} = \frac{BAC}{CPI_{(cum)}}$$

$$EAC \text{ (Highest Estimate)} = ACWP_{(cum)} + \frac{BAC - BCWP_{(cum)}}{\{CPI_{(cum)} \times SPI_{(cum)}\}}$$

**TO COMPLETE PERFORMANCE INDICES**

$$TCPI_{(eac)} = \frac{BAC - BCWP_{(cum)}}{EAC - ACWP_{(cum)}}$$

**Legend:**

- ACWP—Actual Cost of Work Performed
- AUW—Authorized Unpriced Work
- BAC—Budget at Completion
- BCWP—Budgeted Cost of Work Performed
- BCWS—Budgeted Cost of Work Scheduled
- CBB—Contract Budget Base (NCC+AUW)
- CPI—Cost Performance Index
- CV—Cost Variance
- EAC—Estimate at Completion (Government)

- MR—Management Reserve
- NCC—Negotiated Contract Cost
- PMB—Performance Measurement Baseline
- SPI—Schedule Performance Index
- SV—Schedule Variance
- TAB—Total Allocated Budget
- TCPI—To Complete Performance Indices
- VAC—Variance at Completion
- WBS—Work Breakdown Structure

DAU PROGRAM MANAGERS TOOL KIT

## CONTRACTING—COMPONENTS OF CONTRACT PRICE

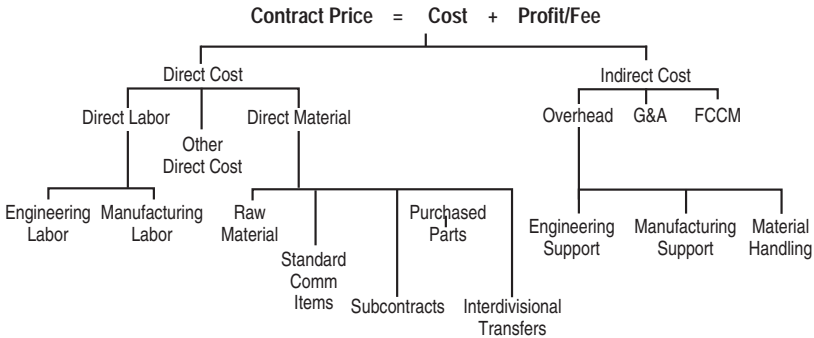

### TYPICAL CONTRACT TYPE BY PHASE

CR	TD	SDD/SI	SDD/SD	PROD
CPFF, FFP	CPFF, FFP	CPFF, CPIF	CPIF, CPAF	FPI(F), FFP

## TYPES OF CONTRACTS

**Cost Family**—Appropriate when product not well defined; high risk; contractor provides best efforts; Government pays all allowable costs. Fee varies by type.

**CPFF**—Fee same regardless of actual cost outcome.

**CPIF**—Actual fee earned computed by applying share ratio to over/under run, subject to min/max fee limits.

**Fixed Price Family**—Product well defined, low risk; contractor must deliver product.

**FFP**—Price fixed regardless of actual cost incurred.

**FPI(F)**—Final price computed by applying share ratio to over/underrun, subject to ceiling price limitation.

**AF**—Either stand-alone Cost Plus Award Fee (CPAF) or combined with cost or fixed price types. AF unilaterally determined by government based on subjective evaluation of contractor's performance.

**Fee Limits: CPFF**—Fee limited to 15% for R&D; 10% for production and services. No statutory or FAR/DFARS regulatory limitation on other contract types.

**Legend:**

AF—Award Fee  
 CPAF— Cost Plus Award Fee  
 CPFF— Cost Plus Fixed Fee  
 CPIF— Cost Plus Incentive Fee  
 CR—Cost Reimbursement  
 FAR/DFARS— Federal Acquisition Regulation/  
 Defense FAR Supplement  
 FCCM— Facilities Capital Cost of Monies  
 FFP— Firm Fixed Price

FPI(F)—Fixed Price Incentive (Firm Target)  
 ODC—Other Direct Cost  
 G&A—General and Administrative (Expense)  
 PROD—Production  
 R&D—Research and Development  
 SD—System Development  
 SDD— System Development and Demonstration  
 SI— System Integration  
 TD— Technology Development

## CONTRACT TYPE FEATURES

	<b>FIXED PRICE</b>	<b>COST REIMBURSEMENT</b>
Promise	Delivery	Best Efforts
Contractor Risk	High	Low
Cash Flow	Delivery	As Incurred
Progress Payments %	75/90/95	N/A
Administration	Low	High
Fee Limit %	None	15/10/6 on CPFF

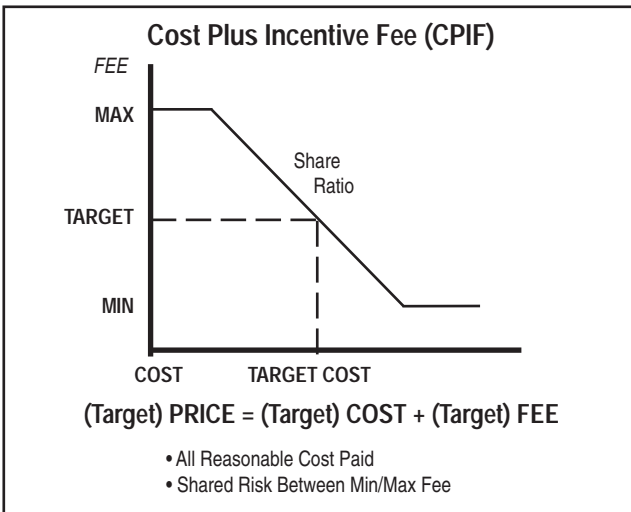
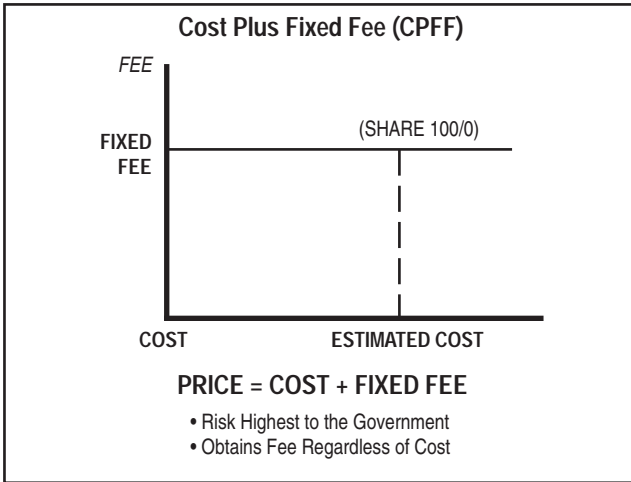

DAU PROGRAM MANAGERS TOOL KIT

**CONTRACT TYPE FEATURES**

(Continued)

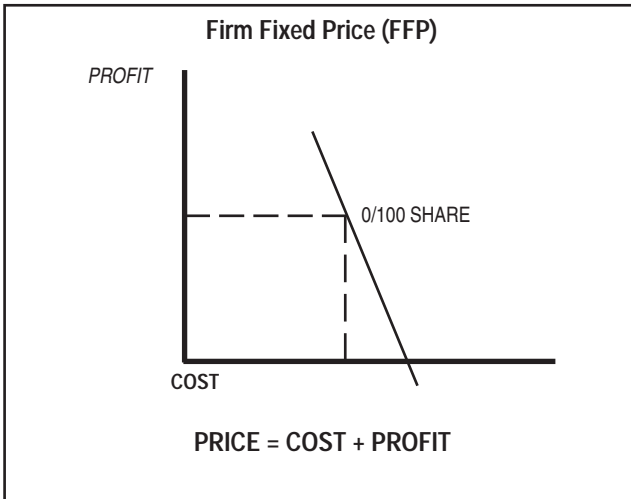
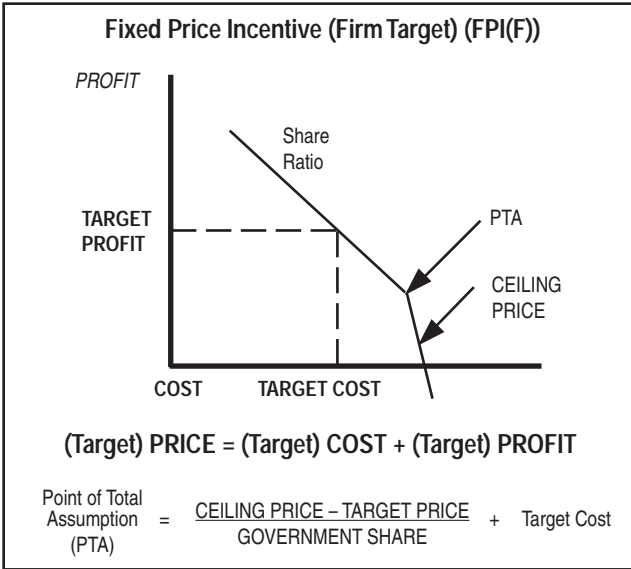

### PRE-SOLICITATION PROCESS

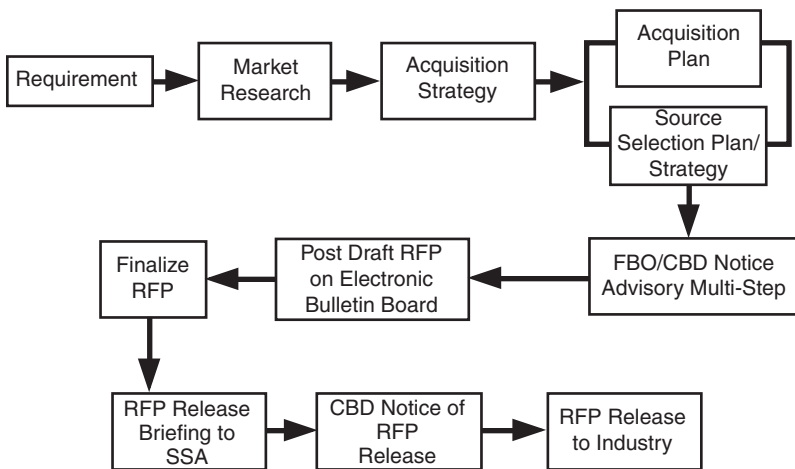

### POST-SOLICITATION PROCESS

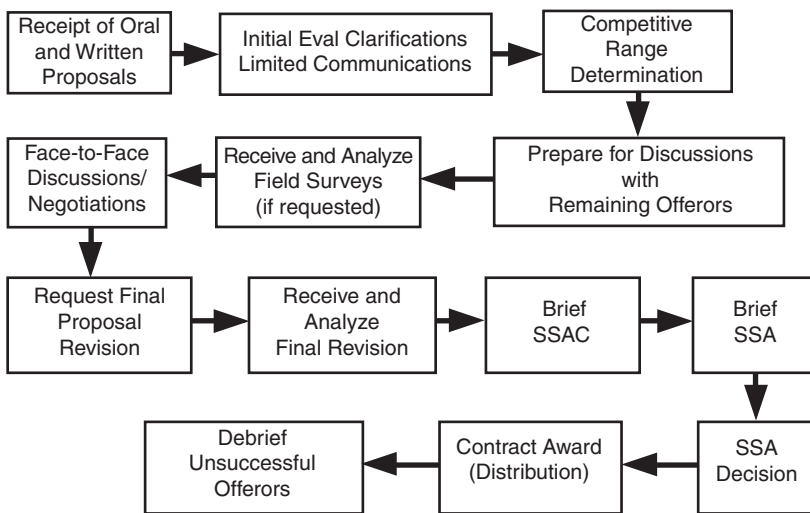

<b>LEGEND:</b>	FBO/CBD – FedBizOps/Commerce Business Daily	RFP – Request for Proposal
		SSA – Source Selection Authority
		SSAC – Source Selection Advisory Council

## DAU PROGRAM MANAGERS TOOL KIT

### OTHER WAYS TO BUY

- **GSA Multiple Award Schedules (MAS)**
  - General Services Administration contracts for both products and services—available to all agencies.
- **Government–Wide Agency Contracts (GWACs)**
  - Similar to MAS but more restricted in products and services available.
- **Indefinite Delivery/Indefinite Quantity Contracts**
  - Task orders (services) and delivery orders (products) issued under omnibus umbrella contract.
- **Other Transactions (OT)**
  - **Defined:** Vehicles used for basic, applied and advanced research projects and prototype development. OTs are not contracts, grants, or cooperative agreements.
  - **Objective:** Attract commercial companies and consortia that historically have not done business with the Department of Defense because of statutory and/or regulatory requirements. OTs are not subject to the Federal Acquisition Regulation. *Designed to increase DoD access to dual-use technologies.*
  - **Research Projects:**
    - ◆ Where practical, government cost share should not exceed cost share of other parties.
    - ◆ Use OT when standard contract, grant, or cooperative agreement is not appropriate.
  - **Prototype Projects:**
    - ◆ Must be directly relevant to weapons or weapon systems proposed to be acquired or developed by DoD.
  - **Constraints:**
    - ◆ At least one nontraditional contractor participating.
    - ◆ If no nontraditional contractor participates, 1/3 of cost paid by parties other than federal government or senior procurement executive justifies transaction.
  - **OT Guide for Prototype Projects, January 2001.**

## CONTRACTOR PROFITABILITY RATIOS

The basic concept of profitability ratios is to measure net income against revenue or against the investment required to produce it. There are three principal profitability ratios with which you should be familiar. They are:

1. **Return on Sales**, which shows what percentage of dollars are left after the company has paid for all costs, interest, and taxes. It is expressed as:

$$\text{Return on Sales} = \frac{\text{Net Income}}{\text{Sales}}$$

2. **Return on Total Assets**, which looks at the efficiency with which management has used its resources, the company's assets, to generate income. It is computed as:

$$\text{ROA} = \frac{\text{Net Income}}{\text{Total Assets}}$$

As noted, **Return on Assets** addresses how well management utilizes the assets of the firm in generating income. The ROA formula reflects the combined result of Return on Sales and the total asset turnover ratio (total sales/total assets), broken down as follows:

$$\text{ROA} = \frac{\text{Net Income}}{\text{Total Sales}} \times \frac{\text{Total Sales}}{\text{Total Assets}}$$

3. **Return on Stockholders' Equity** measures the rate of return on the owners' investment—their equity in the company. This is also known as **Return on Equity**:

$$\text{ROE} = \frac{\text{Net Income}}{\text{Stockholders' Equity}}$$

ROE can also be broken into two components: return on assets and financial leverage (a ratio reflecting the relationship of creditor to owner financing—expressed as total assets/ stockholders equity). This is shown by:

$$\text{ROE} = \frac{\text{Net Income}}{\text{Total Assets}} \times \frac{\text{Total Assets}}{\text{Stockholders' Equity}}$$

These profitability ratios give three different viewpoints concerning the "bottom line" on the income statement—how much net profit is being made on each sale, how much is being made for the assets that are employed, and how much is being made for the company owners. Contractor profitability ratios for the aerospace/defense industry for the period of 1980 to date are shown on page 38.

From an owner's perspective, another profitability ratio you may be aware of is **Earnings Per Share**:

$$\text{EPS} = \frac{\text{Net Income}}{\text{Number of Shares of Common Stock Outstanding}}$$

<b>Legend:</b>	EPS—Earnings Per Share	ROA—Return on Assets	ROE—Return on Equity
----------------	------------------------	----------------------	----------------------

## DAU PROGRAM MANAGERS TOOL KIT

## AEROSPACE/DEFENSE INDUSTRY CONTRACTOR PROFITABILITY RATIOS

### Aerospace/Defense Industry Contractor Profitability Ratios

	Return On Sales (NI/S)	Asset Turnover (S/TA)	Return On Assets (NI/TA)	Financial Leverage (TA/SE)	Return On Equity (NI/SE)
1980	4.3	1.21	5.2	3.08	16.0
1981	4.4	1.18	5.2	3.06	16.0
1982	3.3	1.12	3.7	3.24	12.0
1983	3.5	1.17	4.1	2.98	12.1
1984	4.1	1.15	4.7	3.00	14.1
1985	3.1	1.13	3.6	3.17	11.1
1986	2.8	1.07	3.1	3.13	9.4
1987	4.1	1.07	4.4	3.32	14.6
1988	4.3	1.02	4.4	3.39	14.9
1989	3.3	1.00	3.3	3.24	10.7
1990	3.4	1.00	3.4	3.38	11.5
1991	1.8	1.06	1.9	3.21	6.1
1992	-1.4	0.86	-1.2	4.33	-5.2
1993	3.6	0.97	3.5	3.80	13.2
1994	4.7	0.92	4.3	3.44	14.8
1995	3.8	0.92	3.5	3.17	11.1
1996	5.6	0.91	5.1	3.35	17.1
1997	5.2	0.92	4.8	3.60	17.3
1998	5.0	0.96	4.8	3.73	18.0
1999	6.5	0.95	6.2	3.52	21.8
2000	4.7	0.91	4.3	3.30	14.2
2001	3.9	0.92	3.6	3.22	11.6
2002	4.1	0.90	3.7	3.16	11.7
2003	3.1	0.84	2.6	3.81	9.9
<b>AVERAGE</b>	3.8	1.0	3.8	3.4	12.7

Source: Aerospace Industries Association

**Legend:**

NI/S—Net Income/Sales

NI/SE—Net Income/Stockholders' Equity

NI/TA—Net Income/Total Assets

S/TA—Sales/Total Assets

TA/SE—Total Assets/Stockholders' Equity

# LOCKHEED MARTIN CORP.—DUPONT FORMULA ANALYSIS (AN EXAMPLE)

Fiscal Year	Return on Sales %	Total Asset Turnover	Return on Assets %	Financial Leverage	Return on Equity %
1999	1.53%	0.826	1.26%	4.757	6.01%
2000	-2.11%	0.807	-1.71%	4.249	7.25%
2001	-4.36%	0.866	-3.77%	4.301	-16.23%
2002	1.88%	0.985	1.85%	4.600	8.53%
2003	3.31%	1.216	4.02%	3.874	15.59%

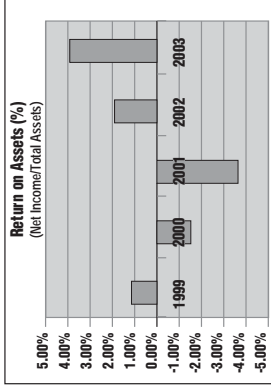
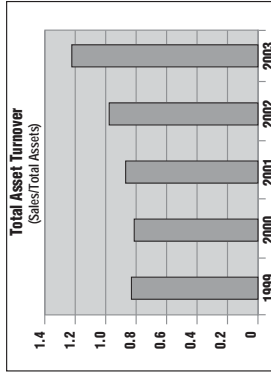
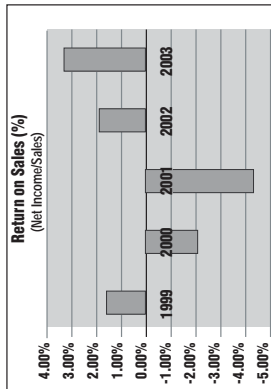

X

=

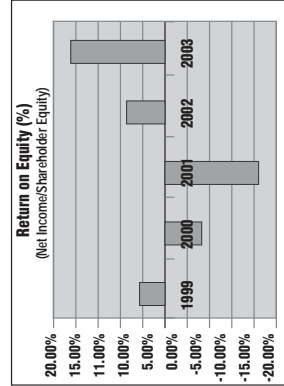
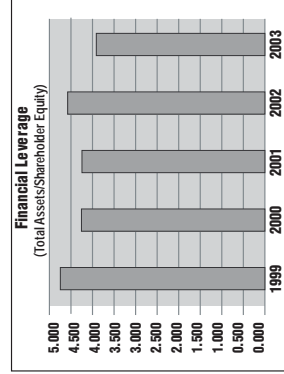
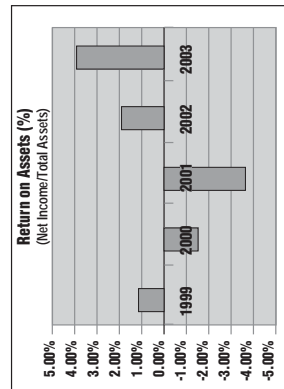

X

=

DAU PROGRAM MANAGERS TOOL KIT

### CASH CYCLE

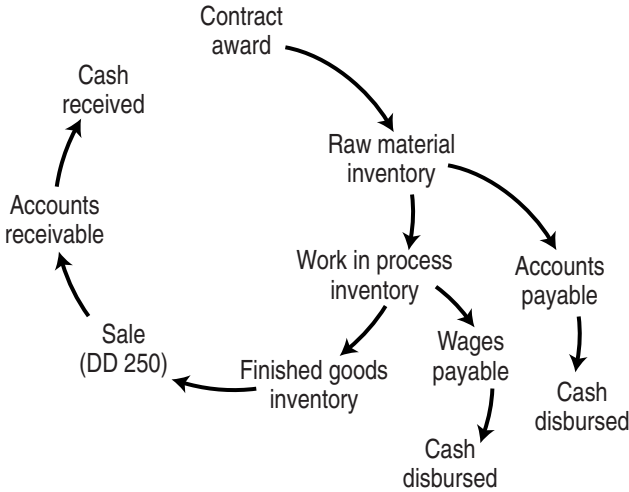

### CONTRACTOR FINANCING AND PAYMENTS

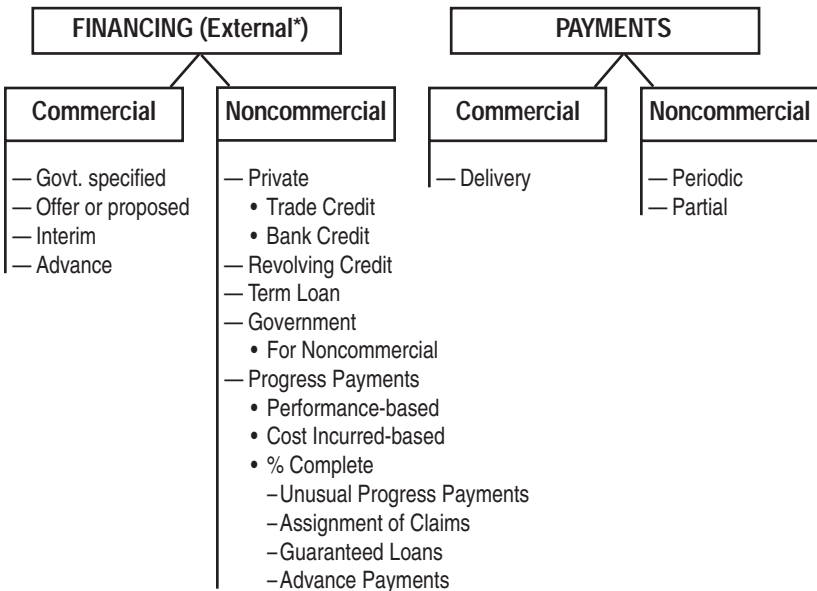

\*Internal Contractor Financing— Retained Earnings

## DIRECT AND INDIRECT COSTS

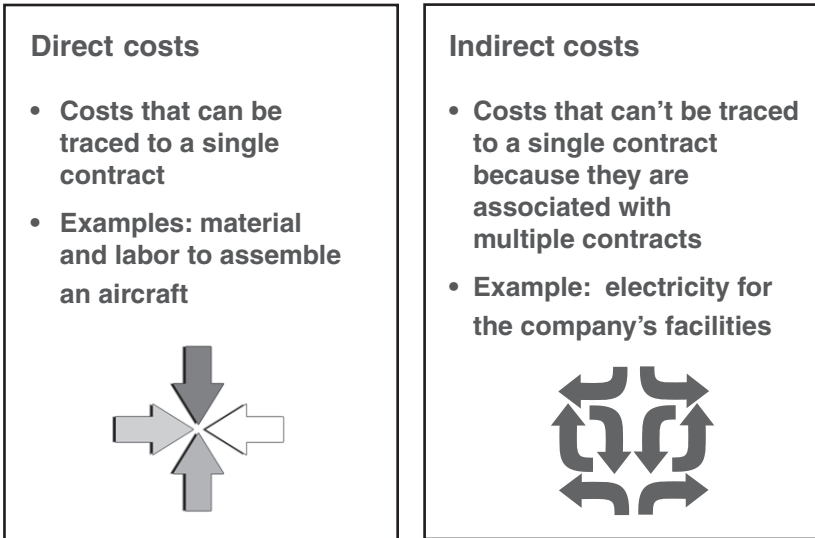

## ASSIGNING INDIRECT COSTS

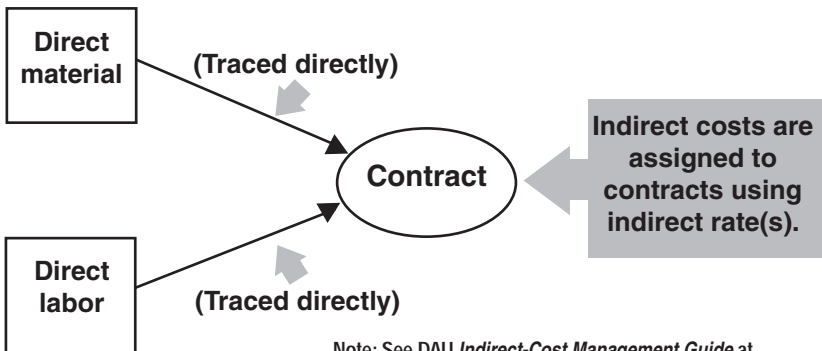

Note: See DAU *Indirect-Cost Management Guide* at [www.dau.mil/pubs/gdbks/icmguide.asp](http://www.dau.mil/pubs/gdbks/icmguide.asp).

### Calculation of Indirect Rates

$$\text{INDIRECT RATE} = \frac{\text{Indirect Cost Pool}}{\text{Allocation Base}}$$

## DAU PROGRAM MANAGERS TOOL KIT

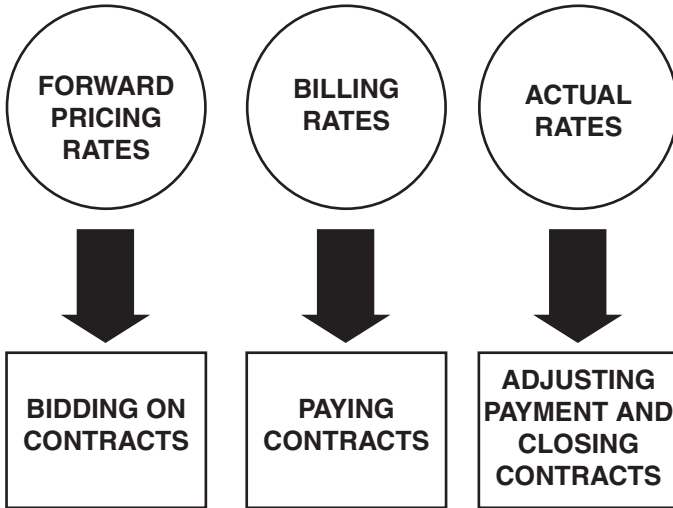
**LIFE CYCLE OF INDIRECT COST RATES****CONTRACTOR'S COST PROPOSAL****EXAMPLE**

Direct material	\$ 40,000
Material handling 10%	4,000
Direct engineering labor	6,000
Engineering overhead 100%	6,000
Direct manufacturing labor	12,000
Manufacturing overhead 150%	18,000
Other direct costs	<u>6,000</u>
Subtotal	92,000
General and administrative 25%	<u>23,000</u>
Total cost	115,000
Profit 15%	17,250
Cost of money for facilities capital	<u>1,500</u>
<b>Price</b>	<b>\$133,750</b>

## CONTRACTOR BUSINESS PLANNING PROCESS OUTPUTS

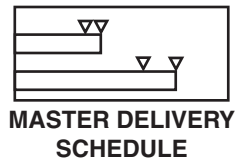
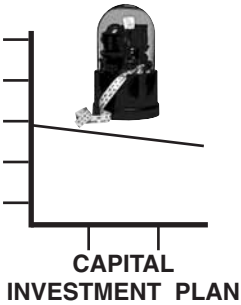
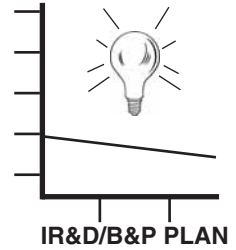
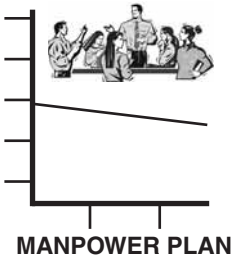
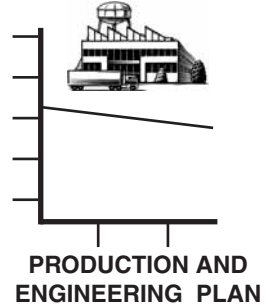
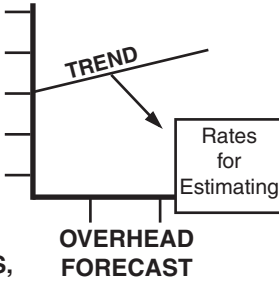

## DAU PROGRAM MANAGERS TOOL KIT

## LIFE CYCLE LOGISTICS

- The planning, development, implementation, and management of a comprehensive, affordable, and effective systems-support strategy, within Total Life Cycle Systems Management. Life cycle logistics encompasses the entire system's life cycle including acquisition (design, develop, test, produce, and deploy), sustainment (operations and support), and disposal.

### PRINCIPAL LIFE CYCLE LOGISTICS GOALS/OBJECTIVES

- Influence product design for affordable System Operational Effectiveness.
- Design and develop the support system utilizing Performance-Based Logistics.
- Acquire and concurrently deploy the supportable system, including support infrastructure.
- Maintain/improve readiness, improve affordability, and minimize logistics footprint.

### SYSTEM OPERATIONAL EFFECTIVENESS (SOE)

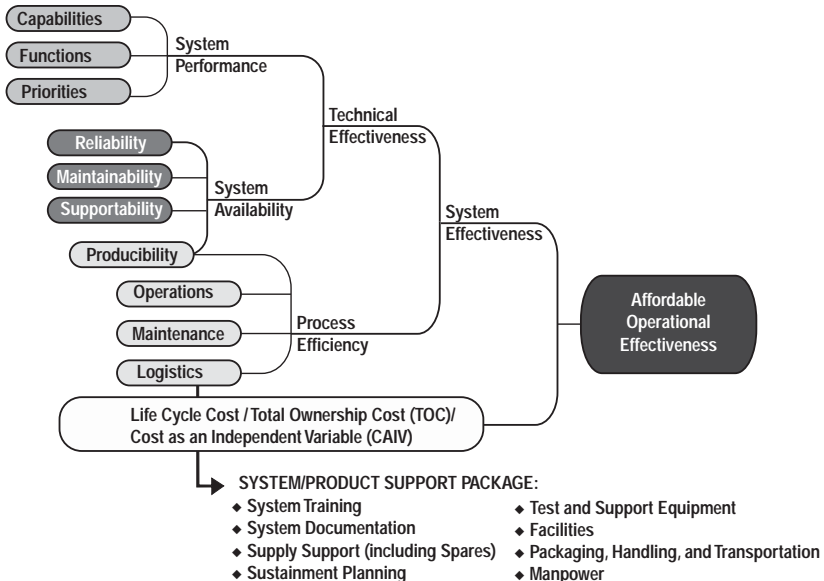

## BEST PRACTICE: Support Elements

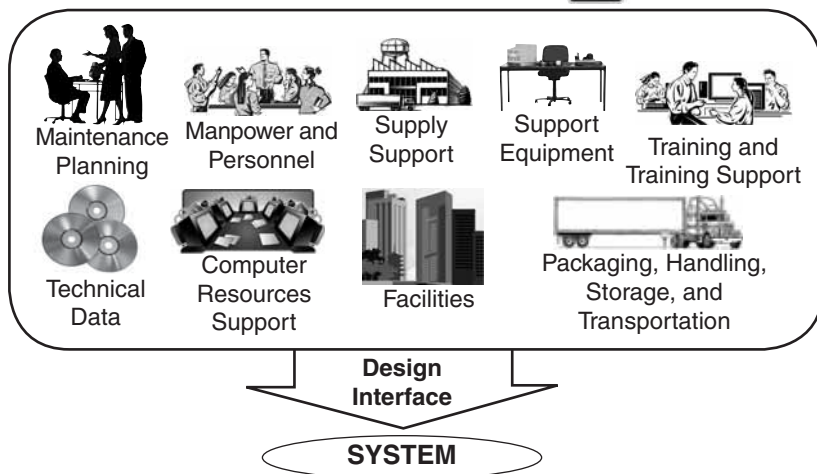

## SUPPORT ELEMENT DEFINITIONS

**Maintenance Planning** – establishes maintenance concepts and requirements.

**Manpower and Personnel** – identification of personnel skills, grades, and quantity required to support operation and maintenance of system.

**Supply Support** – determine requirements to acquire and manage spares and repair parts.

**Support Equipment** – identify all equipment required to support operation and maintenance of the system.

**Technical Data** – scientific and technical information used to support systems acquisition.

**Training and Training Support** – determine requirements to acquire training devices and conduct training of operators and maintenance personnel.

**Computer Resources Support** – identification of facilities, hardware, software, and support tools to operate and support embedded computer systems.

**Facilities** – identify real property required to support system.

**Packaging, Handling, Storage, and Transportation** – identify designs and methods to ensure the system is preserved, packed, stored, handled, and transported properly.

**Design Interface** – relationships of logistics-related design parameters to readiness and support resources requirements; influence design for supportability.

Note: Under Performance-Based Logistics (PBL), support elements are still valid even though the government is buying results and solutions, not specific resources or processes.

DAU PROGRAM MANAGERS TOOL KIT

LIFE CYCLE LOGISTICS LINKAGE TO DEFENSE ACQUISITION PROCESS

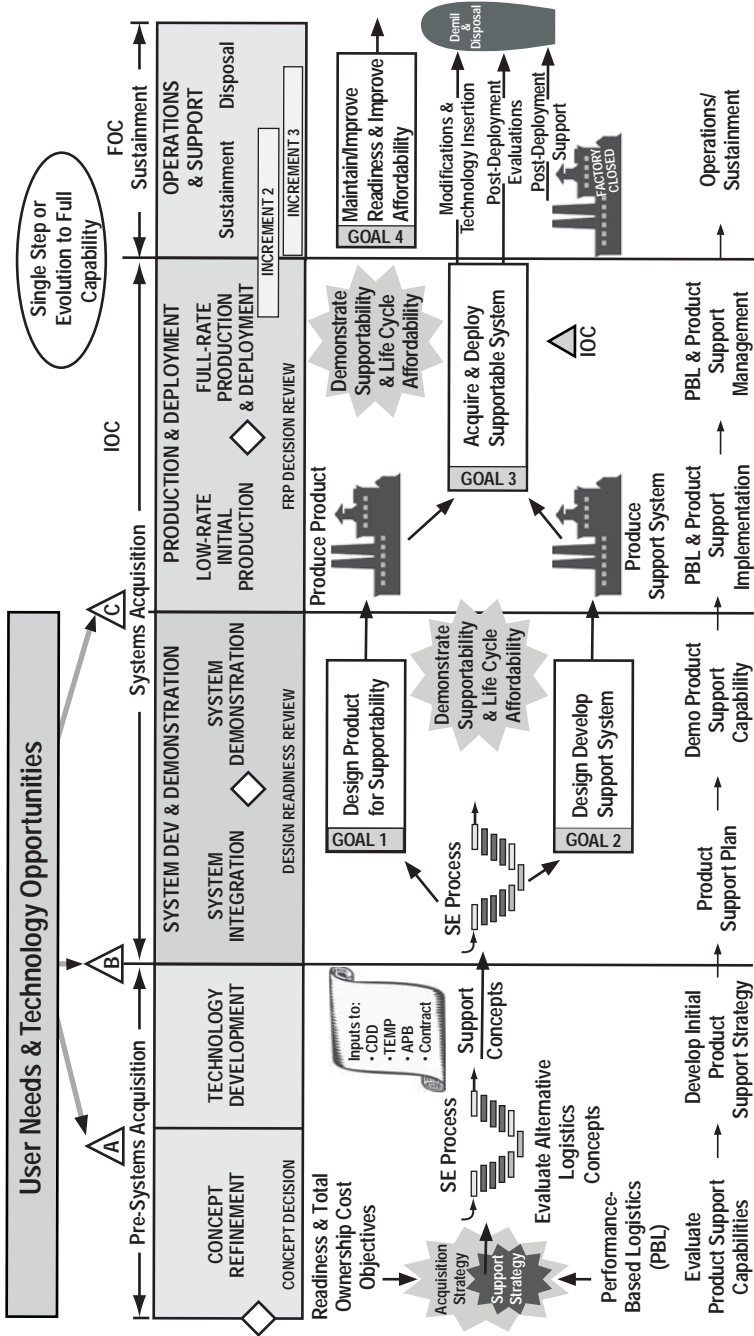

## PERFORMANCE-BASED LOGISTICS (PBL)

- The purchase of support as an integrated, affordable, performance package designed to optimize system readiness and meet performance goals for a weapon system through long-term support arrangements with clear lines of authority and responsibility.
- PBL is DoD's preferred approach for product support implementation.

---

## PERFORMANCE-BASED LOGISTICS (PBL) TOOL KIT

### PBL 12-Step Process Model

<<https://acc.dau.mil/pbl>>

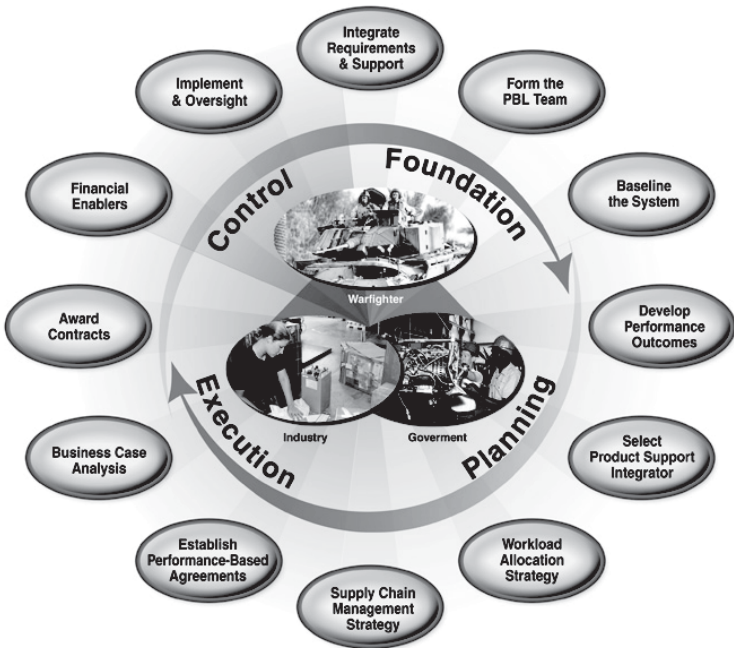

DAU PROGRAM MANAGERS TOOL KIT

**POST-PRODUCTION SUPPORT DECISION PROCESS**

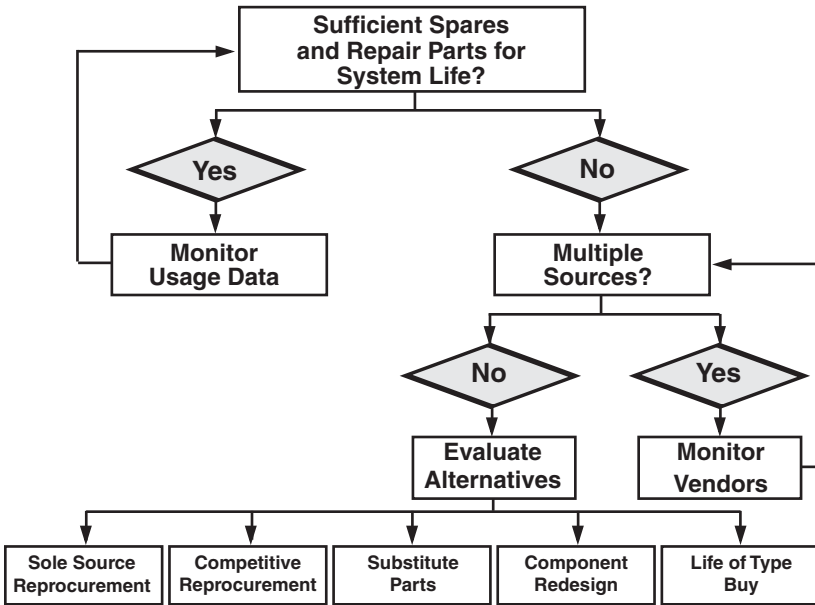

**OPERATIONAL AVAILABILITY**

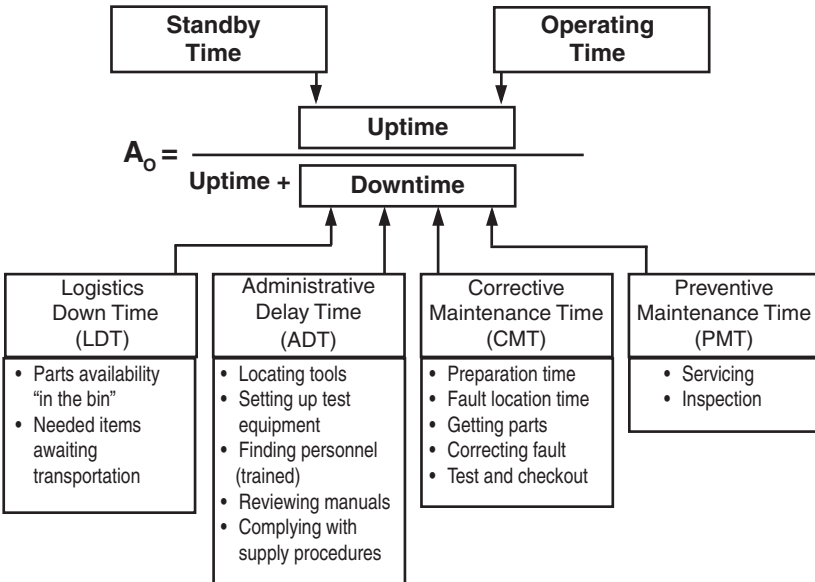

## LIFE CYCLE SUSTAINMENT METRICS

(CJCS 3170, 1 May 2007)

### Material Availability (Key Performance Parameter (KPP))

- A Key Data Element
- Used In Maintenance and Logistics Planning
- Average percentage of time entire population of systems is materially capable for operational use during a specified period
- Formula: 
$$\frac{\text{Number of End Items Operational}}{\text{Total Population of End Items}}$$



### Material Reliability (Key System Attributes (KSA))

- Mean Time Between Failure (MTBF)
- Measure of How Often System Fails/Requires Repair
- Key Data Element In Forecasting Maintenance/Logistics Needs
- Formula: 
$$\frac{\text{Total Operating Hours}}{\text{Total Number of Failures}}$$

### Ownership Cost (KSA)

- O&S costs associated with materiel readiness
- Focused on Sustainment of the System
- Essential Metric For Sustainment Planning and Execution
- Useful For Trend Analyses
- Supports Design Improvements/Modifications
- Uses CAIG O&S Cost Estimating Structure Selected Cost Elements

### Mean Downtime

- Measure of How Long a System Will Be Unavailable After a Failure
- Used In Maintenance/Logistics Planning Process
- Formula: 
$$\frac{\text{Total Down Time for All Failures}}{\text{Total Number of Failures}}$$

## LIFE CYCLE SUSTAINMENT OUTCOME ENABLERS

<<https://acc.dau.mil/log>>

- Performance Based Logistics (PBL)—<<https://acc.dau.mil/pbl>>
- Corrosion Prevention—<<https://acc.dau.mil/corrosion>>
- Item Unique Identification (Iuid)/serialized Item Management (SIM)—<<https://acc.dau.mil/uid>>
- Technical Data/IETM
  - Interactive Electronic Technical Manuals (IETM)—<<https://acc.dau.mil/ietm>>
  - Data Management—<<https://acc.dau.mil/dm>>
- Condition Based Maintenance (CBM+)—<<https://acc.dau.mil/cbm>>
  - Prognostics and Diagnostics—<<https://acc.dau.mil/phm>>
  - Reliability Centered Maintenance (RCM)—<<https://acc.dau.mil/rcm>>
- Continuous Process Improvement (CPI)—<<https://acc.dau.mil/cpi-lean>>
  - Title 10 Requirements/ 50/50, Partnering
  - 50/50—<<https://acc.dau.mil/depot>>
  - Partnering—<<https://acc.dau.mil/ppp>>
- Depot Maintenance Plan—<<https://acc.dau.mil/depot>>
- Diminishing Manufacturing Sources and Material Shortages (DMSMS)/Obsolescence Planning
  - Diminishing Manufacturing Sources and Material Shortages (DMSMS)—<<https://acc.dau.mil/dmsms>>
  - Aging Systems—<<https://acc.dau.mil/agingsystems>>
  - Obsolescence Management—<<https://acc.dau.mil/obsolescence>>
  - Continuous Modernization—<<https://acc.dau.mil/modernization>>
  - Technology Insertion—<<https://acc.dau.mil/techinsertion>>
  - Lead Free Electronics/Solder <<https://acc.dau.mil/leadfree>>
- Training—<<https://acc.dau.mil/training>>
- Integrated Supply Chain Management (SCM)—<<https://acc.dau.mil/scm>>
- Radio Frequency Identification (RFID)—<<https://acc.dau.mil/rfid>>
- Predictive Modeling—<<https://acc.dau.mil/m&s>>
- Long-term Performance Based Agreements (PBA)—<<https://acc.dau.mil/pbar>>



DAU PROGRAM MANAGERS TOOL KIT

# LOGISTICS MANAGEMENT COMMUNITY OF PRACTICE (LOG COP)

*Transforming the Way We Work*

Where YOU can ....

**Find Helpful Tools and Templates**

- Latest PBL Resources
- Supportability Best Practices
- Contracting Lessons Learned

**Get Ahead In YOUR Career**

- Logistics Training and Education
- Latest OSD Policy and Direction
- Logistics Conferences/Events
- Link to Top DoD Web sites

**Connect With Professionals**

- Share Experiences and Ideas
- Start and Join Discussions
- Locate DoD and Industry Experts



<http://acc.dau.mil/log>

## DEFENSE ACQUISITION GUIDEBOOK LIFE CYCLE LOGISTICS

<https://akss.dau.mil/dag>

**Defense Acquisition Guidebook**  
Your Acquisition policy and discretionary kind practice guide.

Defense Acquisition University

Home | Document View | Life Cycle Framework View | Functional/Topic View | Search/Glossary/Acronyms | DAU Resources | Help

### CHAPTER 5 Life Cycle Logistics (LCL)

#### 5.0. Overview

##### 5.0.1. Purpose

This chapter provides program managers with a description of Life-Cycle Logistics (LCL) and its application in the acquisition and sustainment phases. A fundamental element of DoD policy is the designation of the program manager (PM) as the life cycle manager (Total Life Cycle Systems Management (TLCSM)), responsible for effective and timely acquisition and sustainment of the system throughout its life cycle. The PM is responsible for providing the needed product support capability to maintain the materiel readiness, sustainment and operational capability of a system. Emphasis is placed on increasing reliability and reducing logistics footprint in the systems engineering process, and providing for effective product support using Performance-Based Logistics (PBL) strategies. In support of the total system level responsibilities of the PM, PBL strategies may be applied at the system, subsystem, or major assembly level depending upon program unique circumstances and appropriate economic / business case analysis. TLCSM, employing PBL, is the overarching DoD framework implementing the Title 10 requirement to provide sustained materiel readiness to the warfighter. This approach is depicted in Figure 5.0.1.1.

**Total Life Cycle Systems Management (TLCSM)**

**Life Cycle Logistics (LCL)**

LCL in Systems Engineering (SE)      Performance Based Logistics (PBL)

## PROGRAM OFFICE ORGANIZATION STRUCTURES (Examples)

### *“Traditional” or Functional Structure*

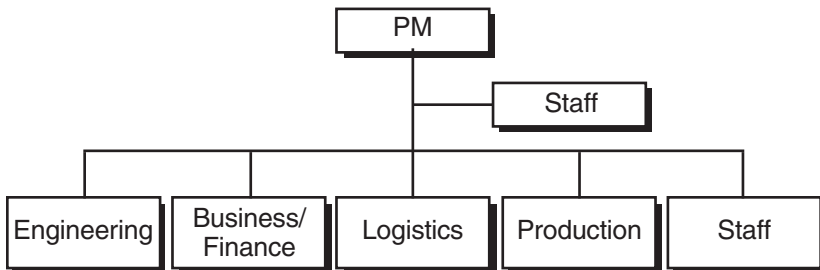

Note: Functional divisions shown are notional.

### *“Pure” Product Structure*

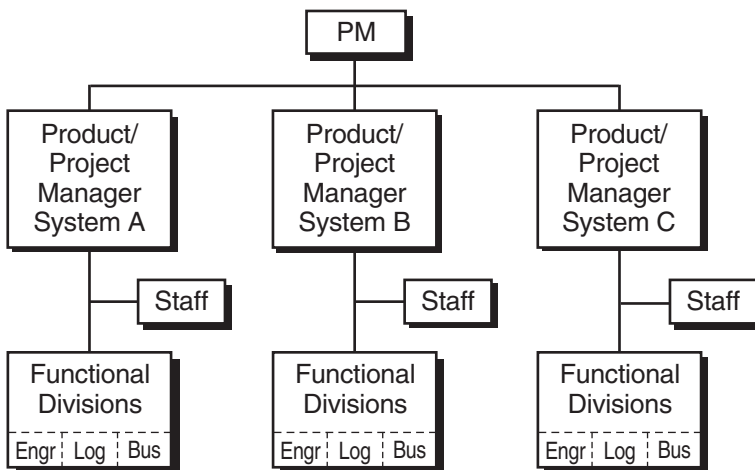

Note: Functional divisions shown are notional.

LEGEND: Engr—Engineering      Log—Logistics      Bus—Business

DAU PROGRAM MANAGERS TOOL KIT

# PROGRAM OFFICE ORGANIZATION STRUCTURES

(Continued)

## Matrix Structure

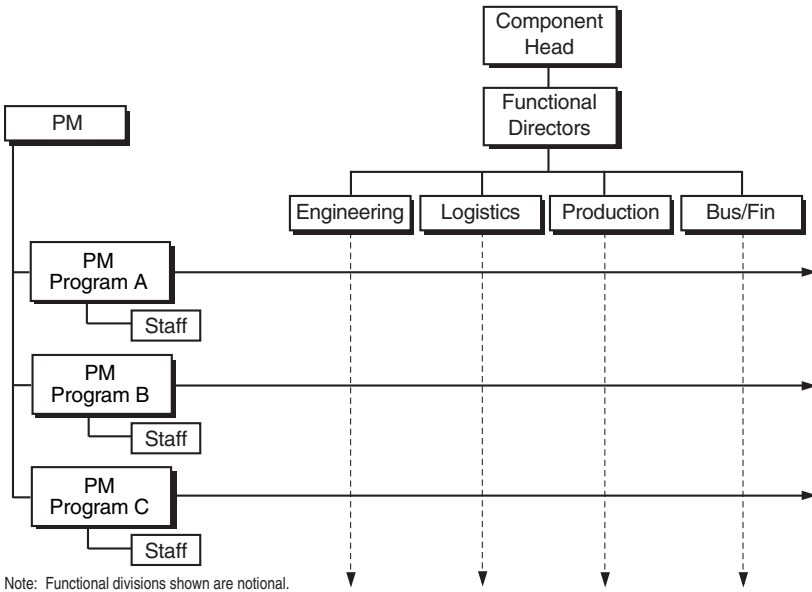

## Integrated Product Teams

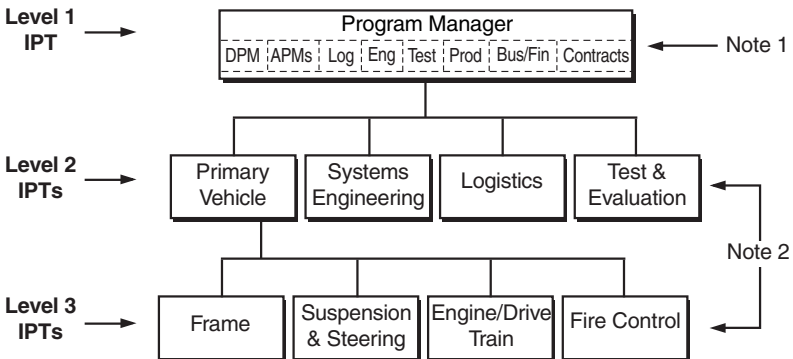

Note 1: Functional titles shown are notional.  
 Note 2: IPTs often align with WBS elements.

## DAU PROGRAM MANAGERS TOOL KIT

## THE ROLE OF MANUFACTURING IN THE ACQUISITION PROCESS

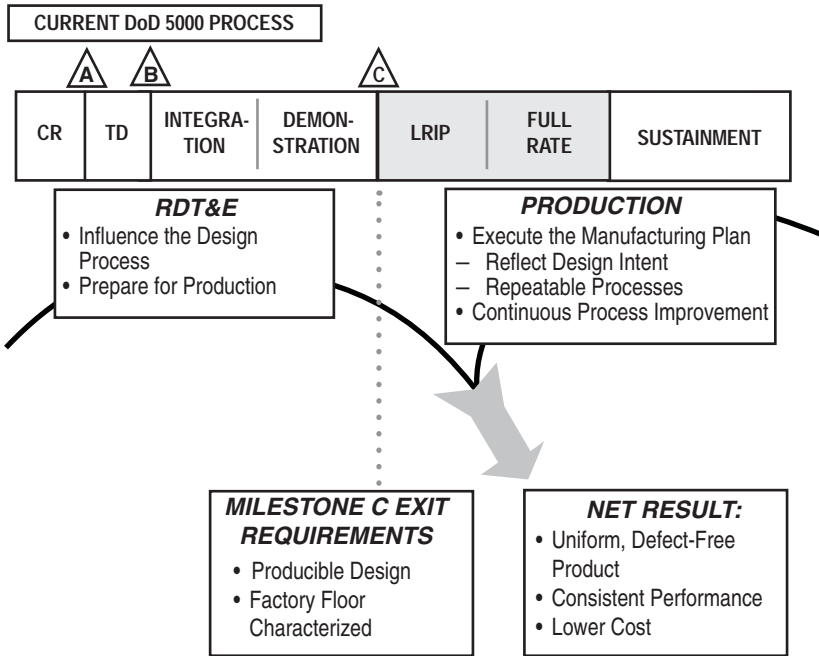

### COMMON PRODUCTION RISKS THAT GREATLY IMPACT COST, SCHEDULE, AND PERFORMANCE

- Unstable requirements/engineering changes
- Unstable production rates and quantities
- Insufficient process proofing
- Insufficient materials characterization
- Changes in proven materials, processes, subcontractors, vendors, components
- Producibility
- Configuration management
- Subcontractor management
- Special tooling
- Special test equipment

## DAU PROGRAM MANAGERS TOOL KIT

# PRODUCIBILITY

### **DEFINITION:**

The measure of relative ease of manufacturing a product. The product should be easily and economically fabricated, assembled, inspected, and tested with high quality on the first attempt that meets performance thresholds.

### **PRODUCIBILITY ISSUES:**

- Design engineering, NOT manufacturing, is the technical group responsibility for producibility. Program offices and design engineers often dislike producibility because it usually requires performance functionality sacrifices (especially if cost is a set value, i.e., CAIV).
- Many design engineers do not have proper training or experience in designing for producibility. Manufacturing facilities must be explicitly recognized as a major design constraint. This includes process capabilities and rate capabilities at each facility.

### ***The PM is responsible for Producibility***

---

## PRODUCIBILITY

### ***Defense Acquisition Guidebook, 4.4.6.1 Producibility***

- Producibility: degree to which system design facilitates timely, affordable, optimum-quality manufacture, assembly, and delivery of system
- Producing system design should be a development priority
- Design engineering efforts concurrently develop:
  - Producing and testable design
  - Capable manufacturing processes
  - Necessary process controls to:
    - Meet requirements
    - Minimize manufacturing costs
- PM should use existing manufacturing processes whenever possible
- When design requires new manufacturing capabilities, PM needs to consider process flexibility (e.g., rate and configuration insensitivity)
- Full-rate production necessitates:
  - Stable systems design
  - Proven manufacturing processes
  - Available production facilities and equipment

## QUALITY MANAGEMENT SYSTEMS

### *Defense Acquisition Guidebook, 4.4.7 Quality*

- The PM should allow contractors to define and use their preferred quality management system that meets required program support capabilities.
- The PM will not require International Standards Organization (ISO) registration of a supplier's quality system since there have been instances where ISO 9001-registered supplier products were deficient or life-threatening.
- Contractor's quality management system should be capable of the following key activities:
  - Monitor, measure, analyze, control, and improve processes;
  - Reduce product variation;
  - Measure/verify product conformity;
  - Establish mechanisms for field product performance feedback; and
  - Implement an effective root-cause analysis and corrective action system.

**Notes:** ISO 9000 Series International Quality Standard is considered a Basic Quality system, but the focus is still on "Document what you do. Do what you document."

Advanced Quality Systems (AQS), such as the new SAE AS9100B Aerospace industries' quality standard, focus on achieving customer satisfaction via use of key characteristics identification and control, variation reduction of key characteristics, flow-down of similar process control requirements to suppliers, and many other advanced process-oriented control and improvement techniques.

---

## KEY CHARACTERISTICS AND VARIATION REDUCTION

**GOAL**—Minimize and control variation on both key product characteristics and corresponding key manufacturing process characteristics:

- **Key Characteristics:** The features of a material, process, or part whose variation has a significant influence on product fit, performance, service life, or manufacturability—per SAE AS9100B.
- **Major Sources of Variation:** Insufficient design margins, process (manpower, machinery, methods, etc.), measurement systems, supplier's products.

**WHY:** Direct correlation between deviation from nominal value (i.e., variation) on key characteristics and product quality and functionality.

**TOOLS:** Quality Function Deployment (QFD), Design of Experiments (DOE), Statistical Process Control. (See control chart on next page.)

## DAU PROGRAM MANAGERS TOOL KIT

## KEY CHARACTERISTICS AND VARIATION REDUCTION

(Continued)

$\bar{X}$  (Control Chart)

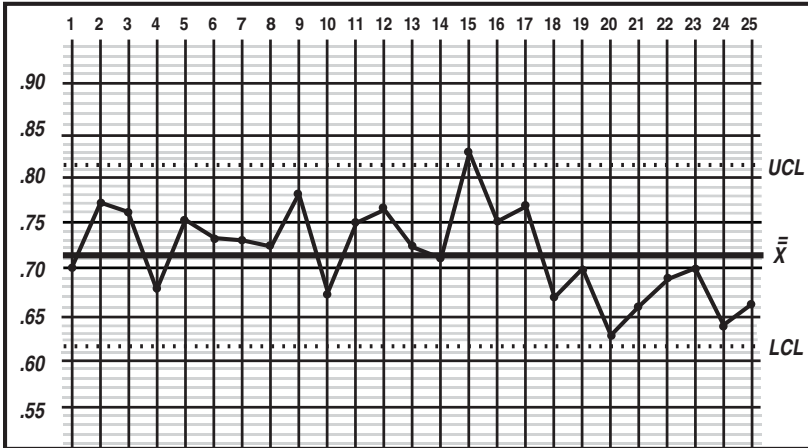

R (Control Chart)\*

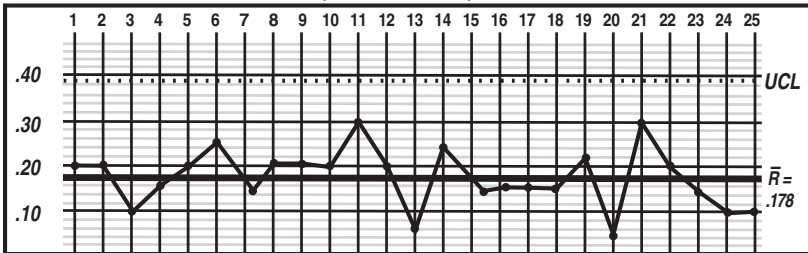

\*Note: No lower control limit for R chart for sample size below 7.

The  $\bar{X}$  (X bar) and R Control Charts are used to monitor manufacturing processes. Upper or Lower Control Limits (UCL or LCL) are **NOT** design specification parameters. Instead, they are predicted boundaries for stable processes, calculated using  $\bar{X}$  (X double bar) (average of sampled process Means),  $\bar{R}$  (R Bar) (the average of the sample Ranges, which are the spreads between extreme values per sample), plus the selected data sample size and process-keyed statistical formulas. Values outside the UCL and/or LCL indicate possible process instability, likely due to uncommon "special" causes of variation. **Caution:** A process in control is desirable because it is predictable, yet it could fail to meet design requirements due to inherent "common" variation and/or because the process average isn't centered on the design nominal value.

Reference: *The Memory Jogger™ II*; ©1994 by GOAL/QPC

## PRODUCTION READINESS REVIEW (PRR)

### **WHY WE DO THEM”**

- Risk Management Tool: Identify program risks and issues and opportunities early and often (small, incremental, proactive—vice big, single, reactive)
- Assess capability of contractor (and subcontractor) to deliver on time, within cost, a product that meets performance and quality requirements
- Assess actual contractor performance (metrics)
- Assess effectiveness of contractor’s corrective/preventative actions
- Measure improvement of contractor’s performance

### **HOW TO DO THEM**

- Write a charter that the program office and contractor both understand
- Coordinate with the Defense Contract Management Agency (DCMA)—use their capability
- Establish areas of assessment with metrics
  - Producibility
  - Engineering Change Orders (ECO)/design stability
  - Manufacturing process control (key characteristics)
  - Cost, time of scrap, rework, and repair
  - Tooling status
  - Subcontractor management (same metrics as listed above)
- Ask questions, touch things, talk to shop floor workers
  - **See what is actually happening on the factory floor rather than the conference room, i.e., go see and talk to the people doing the work**

### **WHEN TO DO THEM**

- Early and often (see *Defense Acquisition Guidebook*, 4.3.3.9.3, Production Readiness Reviews)
- Concurrently with other technical reviews, such as the System Functional Review (SFR), Preliminary Design Review (PDR), and the Critical Design Review (CDR)
- In Systems Integration and Systems Demonstration
- “Final” PRR occurs at end of Systems Demonstration (before Milestone C)
- PRRs should be held in LRIP and beyond IF major changes (to design, manufacturing processes, rates/quantities, etc.) occur during LRIP

---

## ADDITIONAL MANUFACTURING INFORMATION SOURCES

- DAU’s Production, Quality and Manufacturing Information Web site:
  - Go to <[www.dau.mil](http://www.dau.mil)>, select Knowledge Sharing, select Acquisition Community Connection, then see Participate in a Community, and select Production, Quality and Manufacturing
  - Contains references to subjects including DoD Manufacturing Requirements, and Best Business Practices, such as Lean Enterprise, e-Commerce, Six Sigma, Basic and Advanced Quality Systems, Supply Chain Management, etc.
- Best Manufacturing Practices Center of Excellence—<[www.bmpcoe.org](http://www.bmpcoe.org)>
- Lean Aerospace Initiative (LAI)—<<http://web.mit.edu/lean>>

## DAU PROGRAM MANAGERS TOOL KIT

**TEST AND EVALUATION (T&E)—TYPES AND TASKS*****Developmental T&E (DT&E)/Operational T&E (OT&E) Comparisons*****DT&E**

- Technical performance measurement
- Developmental agency responsible (PM)
- Technical Personnel
- Ltd. test articles/each test
- Controlled environment
- All types of test articles
- Contractor involved

**IOT&E**

- Operational effective/suitable
- Operational Test Agency (OTA) responsible
- “Typical” user personnel
- Many test articles/each test
- “Combat” environment/threats
- “Production Rep” test articles
- Contractor may not be allowed

***T&E Required Before Going Beyond Low Rate Initial Production***

- **Production Qualification T&E**—Verify Design Article meets Spec/PM responsible Performed by Contractor and/or Government/DPRO assistance valuable. Readiness for IOT&E.
- **Live Fire T&E (LFT&E)**—Vulnerability and Lethality/Developmental Agency fund and execute DOTE oversight, approval, and Congressional reporting for ACAT I, II, and selected programs.
- **Initial Operational T&E (IOT&E)**—Operational Effectiveness and Suitability/Independent Service OTA plan and manage. DOTE oversight, approval, and Congressional reporting for ACAT I and selected systems.

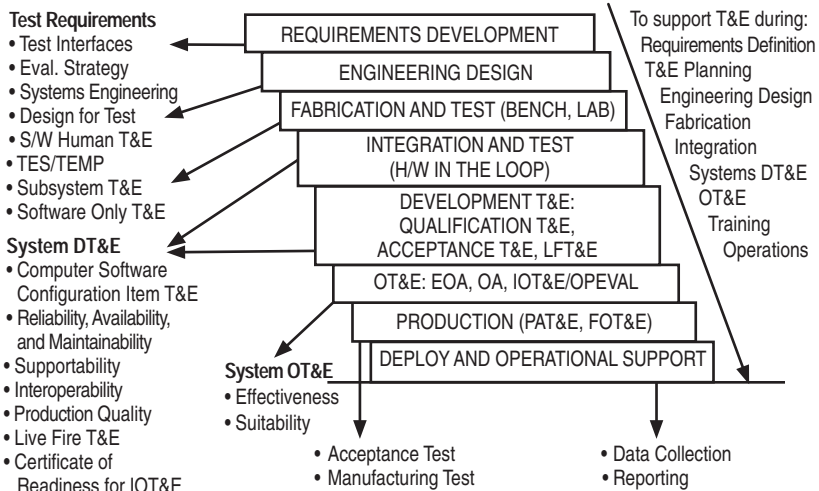
***T&E Tasks and Events*****Models and Simulations Used Throughout the Acquisition Process**

**Use Integrated DT/OT**—Single integrated contractor/government DT and OT team; shared test events and test data; independent data analysis and reporting.

**ACAT I and II Programs**—Require an independent, dedicated IOT&E to proceed beyond Low Rate Initial Production (LRIP).

**AGONIZE OVER THRESHOLDS!**

## TEST AND EVALUATION NOMOGRAPH

**What is this nomograph?** A two-dimensional graphical representation of the cumulative binomial distribution.

**Why use nomograph?** It enables a relatively simple solution to a complex mathematical calculation.

**What does it do?** It allows you to calculate the performance of an item with associated statistical confidence.

### **When do you use it?**

- When your requirement includes a “Confidence Level” with a specific level of performance. For example: THIS missile must hit THAT target 90 percent of the time with 80 percent statistical confidence?
- When the performance of an item under test can be characterized by a binomial distribution.

### **What are the characteristics of a binomial distribution?**

- Result of each event (firing) is independent from other events.
- Probability of success of each event is constant.
- Each event results in a “success” or a “failure.” (In other words, there are no points for being close; each event must be scored as a hit or a miss.)

### **What are some examples of binomially distributed events?**

- Coin flip
- Missile launch
- Rocket firing
- Starting a car

**BOTTOM LINE:** Each of these test events must be graded as “pass” or “fail,” and you must determine the success criteria before the test begins.

The nomograph can be used (pre-test) as a test planning device to determine how many tests will be necessary to verify that specified performance has been met. The nomograph can also be used (post-test) to evaluate test data.

Note: There are two axes on the nomograph. One axis is the total number of trials. The other axis is the total number of failures. Additionally, the nomograph is non-linear.

## DAU PROGRAM MANAGERS TOOL KIT

## T&amp;E NOMOGRAPH (Continued)

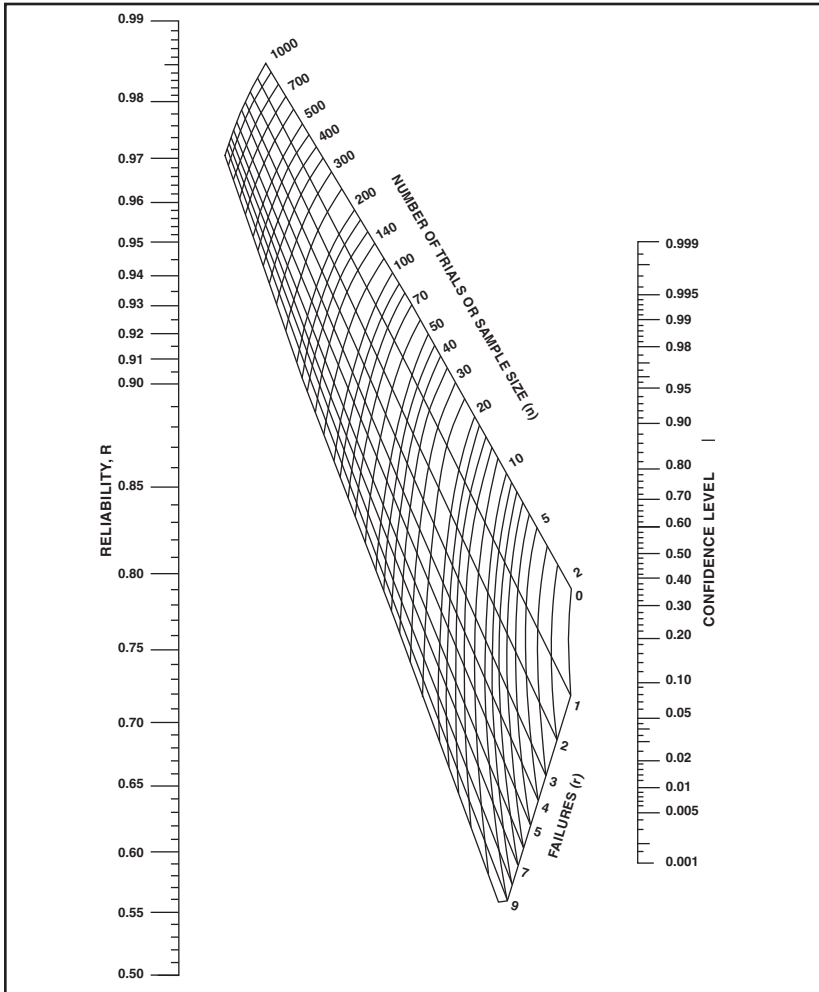
**How do you get a solution?**

- From the data, determine the number of trials (total number of coin flips or missile shots, etc.) and locate the appropriate line on the nomograph.
- Determine the number of failures and locate the appropriate line on the nomograph.
- Draw a point at the intersection of these two lines on the nomograph.
- Any straight line drawn through this point is a valid solution for the data set used.

**For example:**

- Requirement: Your missile must hit the target at least 90% of the time, with at least 80% confidence.
- Given: You fired 20 missiles with 19 hits and 1 failure.
- What is the statistical confidence that you will have 90% success in the field with these missiles fired against THAT target?  
Answer: 60% confidence.
- Did you meet the requirement? NO, you achieved only 60% confidence of hitting THAT target 90% of the time, and the requirement was 80% confidence or better. One other way to look at the same data is to say that you did achieve 90% probability of success, but you only had 60% confidence in this result; either way you look at it, you did not meet the requirement.

**NOTE:** If you had fired 30 missiles and missed only 1 time, you would have achieved the 80% confidence along with the required 90% performance level.

## MODELING AND SIMULATION (M&S) PLANNING

- ACCESS YOUR SERVICE CENTERS OF M&S EXPERTISE
- Establish a simulation coordinating group; the EARLIER the better
- Design long-term M&S applications and the Integrated Digital Environment through the acquisition strategy, Test and Evaluation Management Plan (TEMP), Source Selection Plan (SSP)
- Constructive, virtual, live
- CONTINUOUS PLANNING



PROGRAM PLANNING

Test and Evaluation Strategy/TEMP



### HOW DO WE PLAN?—A NOTIONAL APPROACH

#### Integrated Digital Environment (IDE) Planning

- Establish a business process improvement team
- Identify high payback process areas
- Identify potential legacy systems and data repositories
- Identify user base including remote sites
- Capacity of PC workstations
- Bandwidth of communication lines
- Where servers are/will be located
- Identify legacy system host platforms

#### Modeling and Simulation (M&S) Planning

- Identify high payback process areas
- Identify potential legacy systems, Service/Joint-standard simulations, architectures and data repositories
- Identify where user and simulators are/will be located
- Determine capabilities and architectures of existing simulations
- Network bandwidth requirements
- IDE utilization opportunities
- Interoperability/interface/immersion requirements
- Required capability cap
- Design M&S architectures
- Establish a simulation and Verification, Validation, and Authentication (SVV&A) planning process
- Establish long-term plan, budget, document and implement
- Manage, update, and implement the SSP

Simulation Support Plan (SSP)  
 (Required by Army, Marine  
 Corps, and Air Force)



DAU PROGRAM MANAGERS TOOL KIT

**HIERARCHY OF MODELS AND SIMULATIONS**

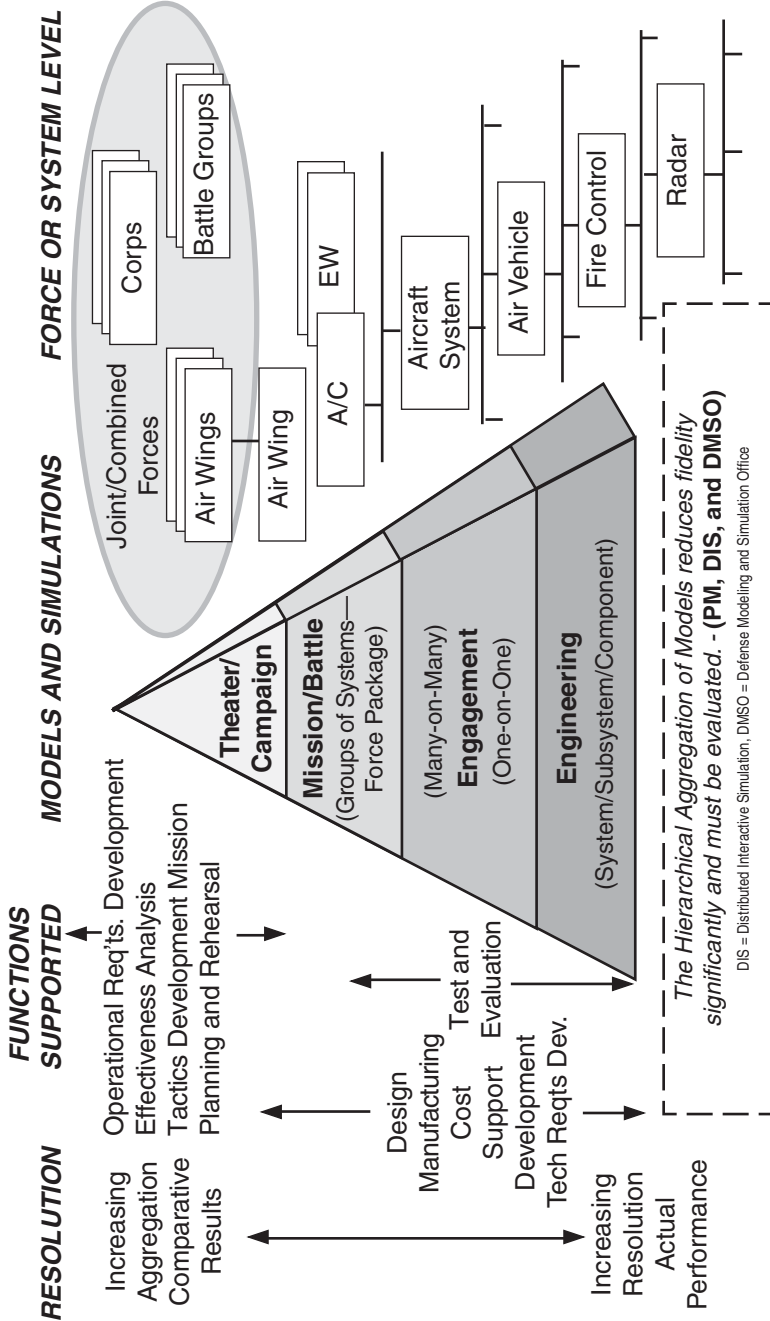

# THE EVOLUTION OF MODELING AND SIMULATION

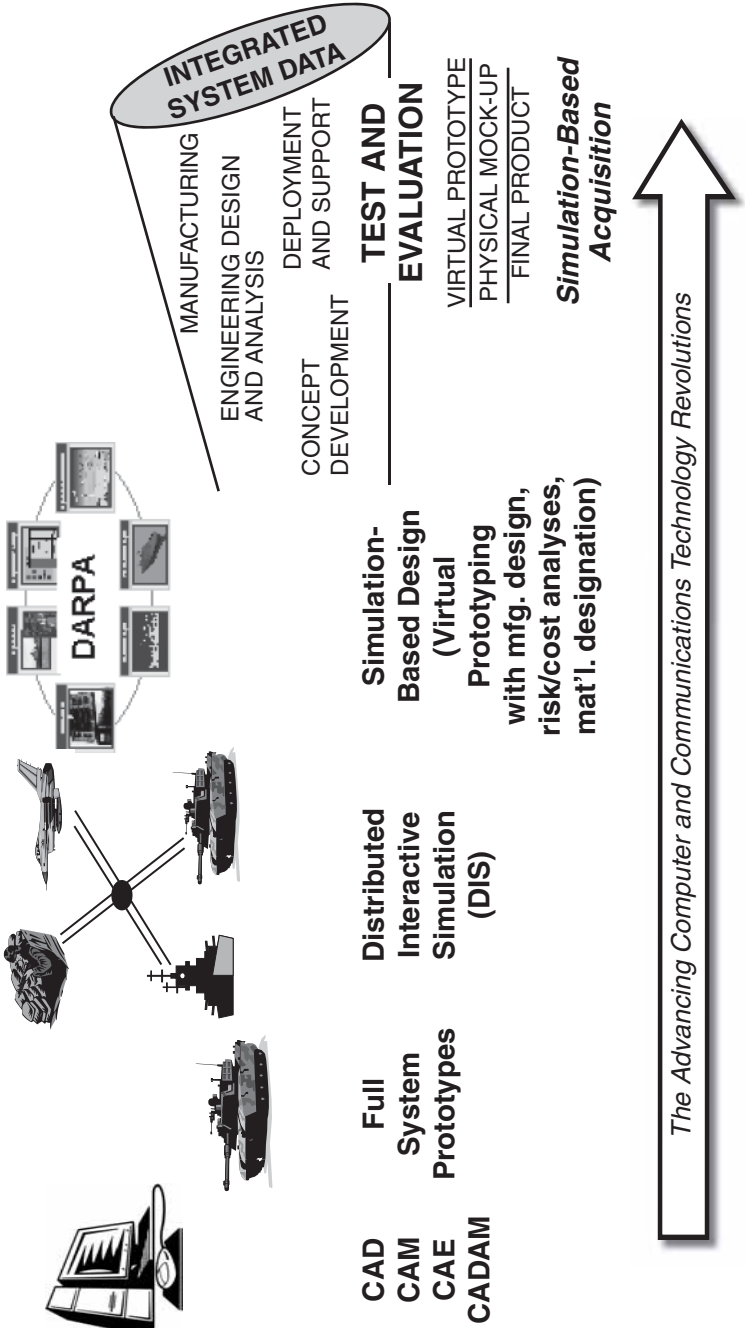

DAU PROGRAM MANAGERS TOOL KIT

## PLANNING AND CONTROL TOOLS

### Gantt Chart (Example)

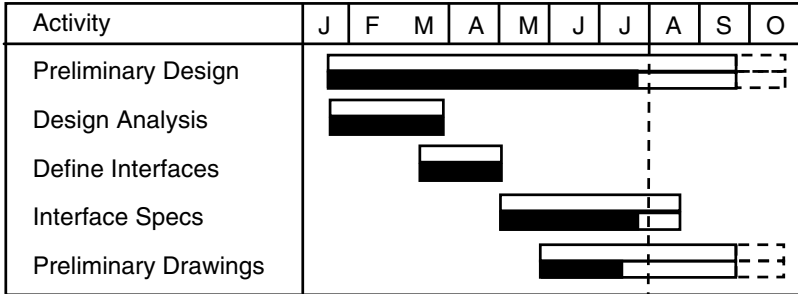

Symbol	Meaning
	Planned activity schedule
	Status of activity
	Forecast completion behind schedule
	Forecast completion ahead of schedule

Current Date

**NOTE:** There is no standard set of Gantt chart symbols.

- Shows planned start and finish dates; may also show progress
- Depicts activities as horizontal bars imposed over a time line
- Primary strengths are simplicity and depicting overall project plan and status
- Can show dependencies between activities (can be difficult to read as the number of activities and dependencies between activities increases)

### Milestone Chart (Example)

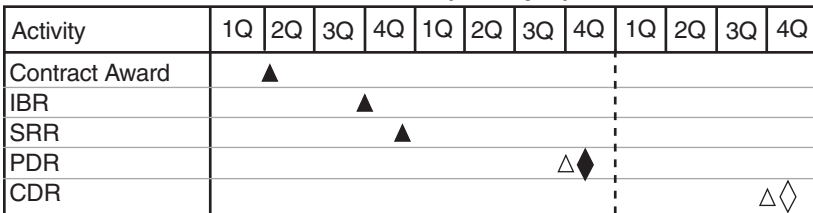

Symbol	Meaning
△	Planned event completion
▲	Actual event completion
△◆	Actual completion behind schedule
△◇	Forecast completion behind schedule

Current Date

- Shows when key events are scheduled and when they are actually accomplished.
- Primary strengths are simplicity and depicting information at the “big picture” level.
- Does not show progress related to events or dependencies between events.

## PLANNING AND CONTROL (Continued)

### Network Schedules

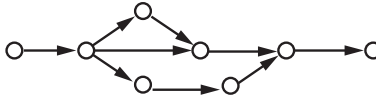

- Graphically portray dependencies and constraints among project activities and the sequence in which the activities occur.
- Allows managers to conduct a systematic, disciplines and thorough review of the activities required to complete the project.
- Provides information about early and late start and finish times.
- Used to determine the project's critical path, and slack or float in schedule activities.
- Generally, there are two types of networks: Arrow Diagramming Method (ADM), and Precedence Diagramming Method (PDM).

### Arrow Diagramming Method (ADM)

- Also known as Activity-on-Arrow (AOA); information about activities is shown above/below the arrows connecting events in the schedules. Events are usually shown as circles, squares, or rectangles (see following page).
- ADM generally treats all relationships (see below) as finish-to-start (i.e., first activity must finish before the next activity can start).
- ADM can show other relationships (e.g., start-to-start, finish-to-finish) through the use of "dummy" activities.

### Precedence Diagramming Method (PDM)

- Also known as Activity-on-Node (AON); information about activities is shown in/on the network nodes. Nodes are usually shown as squares or rectangles (see following page).
- Lines connecting the nodes show the relationships between the activities.
- PDM can show all forms of schedule relationships, including lead and lag situations (see below).

	<p><b>Finish-to-Start.</b> Activity "A" must finish before Activity "B" can start.</p>		<p><b>Start-to-Start.</b> Activity "A" must start before Activity "B" can start.</p>
	<p><b>Finish-to-Finish.</b> Activity "A" must finish before Activity "B" can finish.</p>		<p><b>Start-to-Finish.</b> Activity "A" must start before Activity "B" can finish. Rarely used.</p>

DAU PROGRAM MANAGERS TOOL KIT

**PLANNING AND CONTROL TOOLS**  
Network Schedules (Example)

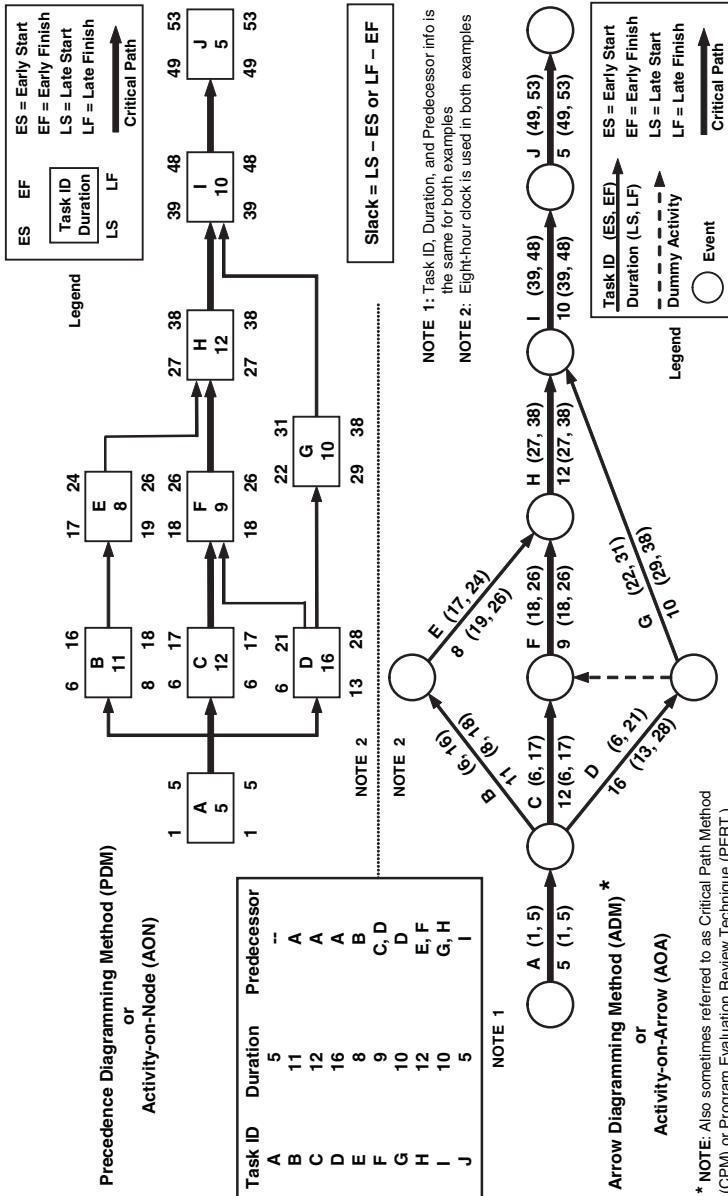

# PLANNING AND CONTROL TOOLS

## Examples of Network Scheduling Software

**Gantt Chart View**

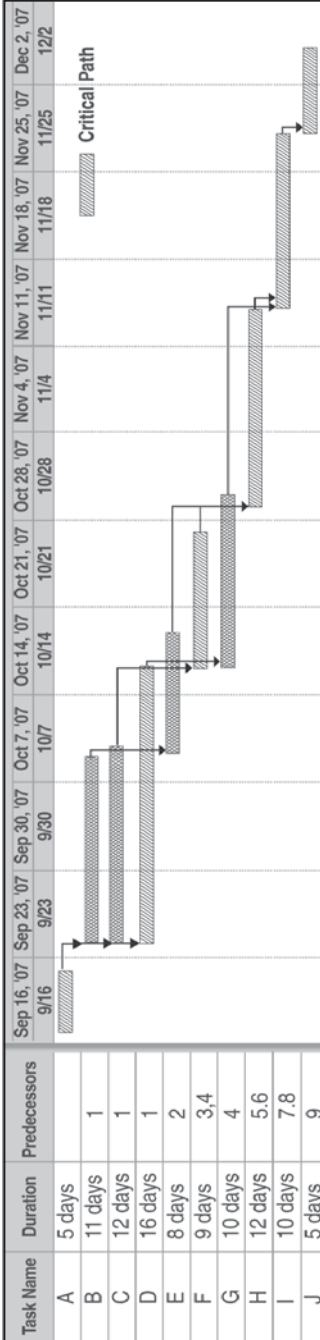

NOTE: Task name, duration, and predecessor information is the same as in Network Schedule on the previous page.

**Network View**

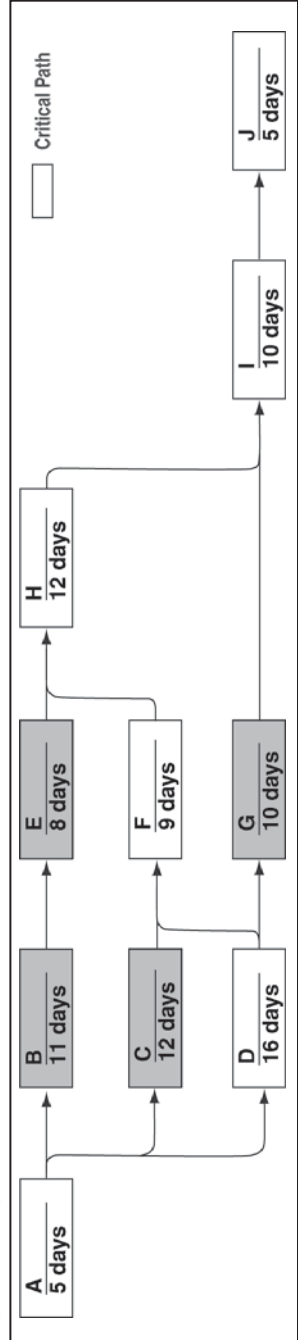



### LEAD TIME CHART

(Use with Line of Balance on next page.)

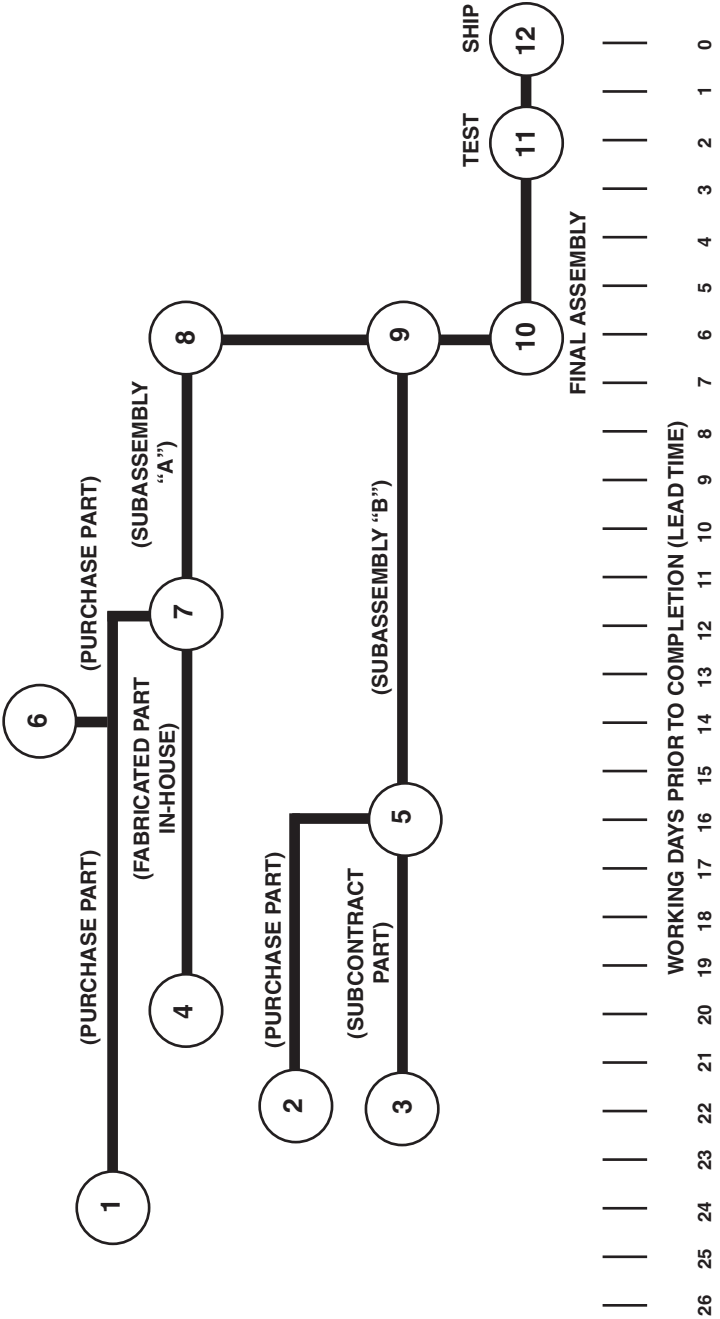



## ACQUISITION PROGRAM BASELINE Key Performance Parameter (KPP)—An Example

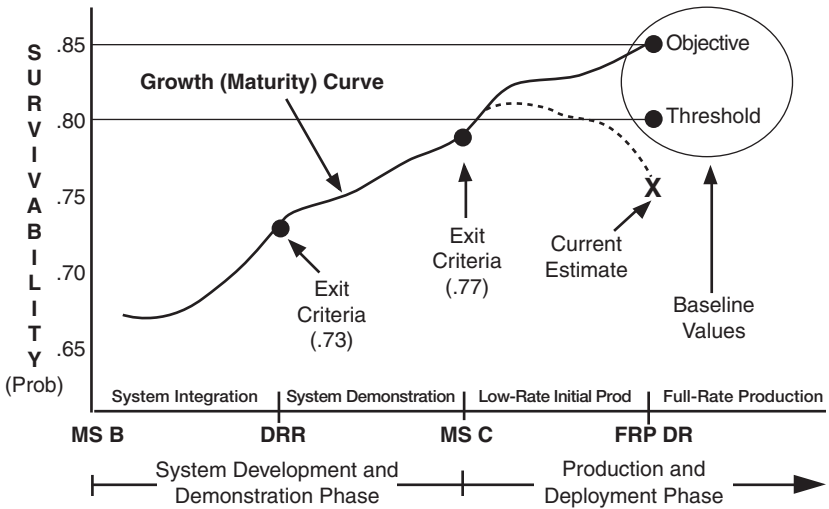

\* In this example, the current estimate falls below the threshold—this represents a baseline breach of performance.

- Every program must have an APB starting at program initiation (normally Milestone B).
- The APB reflects the threshold and objective values for a minimum number of cost, schedule, and performance parameters that describe the program over its life cycle.
- Cost thresholds and objectives reflect major elements of life cycle cost (RDT&E, procurement, PAUC, APUC, etc.)
- Schedule thresholds and objectives reflect critical events (milestone decisions, start of DT/OT, first flight, IOC, etc.)
- Performance thresholds and objectives are key performance parameters (KPPs) extracted verbatim from the CDD/CPD.
- The JROC requires four mandatory KPPs: net-ready, survivability, materiel availability, and force protection. Two additional KPPs are required for selected programs: system training and energy efficiency.
- The MDA may add other significant performance parameters if necessary.
- The APB is signed by PM, PEO, and CAE, as appropriate, and approved by MDA.

### Legend:

MS—Milestone

DRR—Design Readiness Review

FRP DR—Full-rate Production

Design Review

CDD—Capabilities Design Document

CPD—Capabilities Production Document

MDA—Milestone Decision Authority

PM—Program Manager

PEO—Program Executive Officer

CAE—Component Acquisition Executive

IOC—Initial Operational Capability

APUC—Average Procurement Unit Cost

PAUC—Program Acquisition Unit Cost

RDT&E—Research, Development, Test

and Evaluation

JROC—Joint Requirements Oversight

Council

DT/OT—Development Test/Operational Test

DAU PROGRAM MANAGERS TOOL KIT

## RISK MANAGEMENT PROCESS MODEL

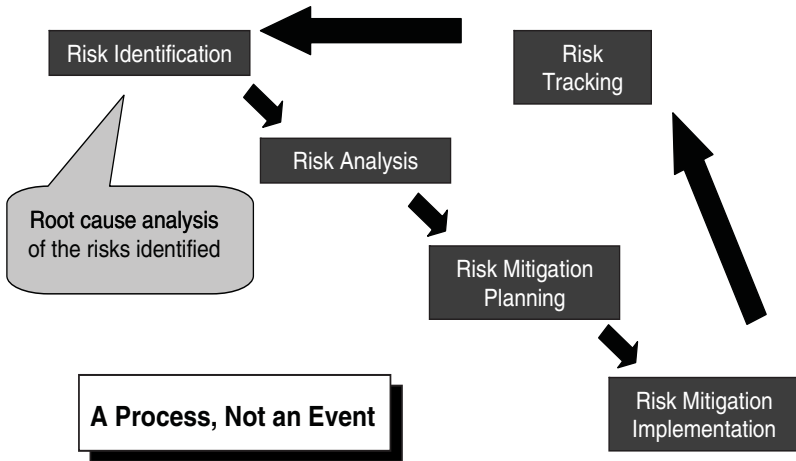

DoD Risk Management Guide  
August 2006

---

## ROOT CAUSE ANALYSIS

- Risk identification includes analysis to identify the root causes of the risks identified.
- Root causes are identified by examining each WBS product and process element in terms of the sources or areas of risk.
- An approach for identifying and compiling a list of root causes to:
  - list WBS product or process elements;
  - examine each in terms of risk sources or areas;
  - determine what could go wrong; and
  - ask “why” multiple times until the source(s) is discovered.

# RISK MANAGEMENT PROCESS—DETAILS

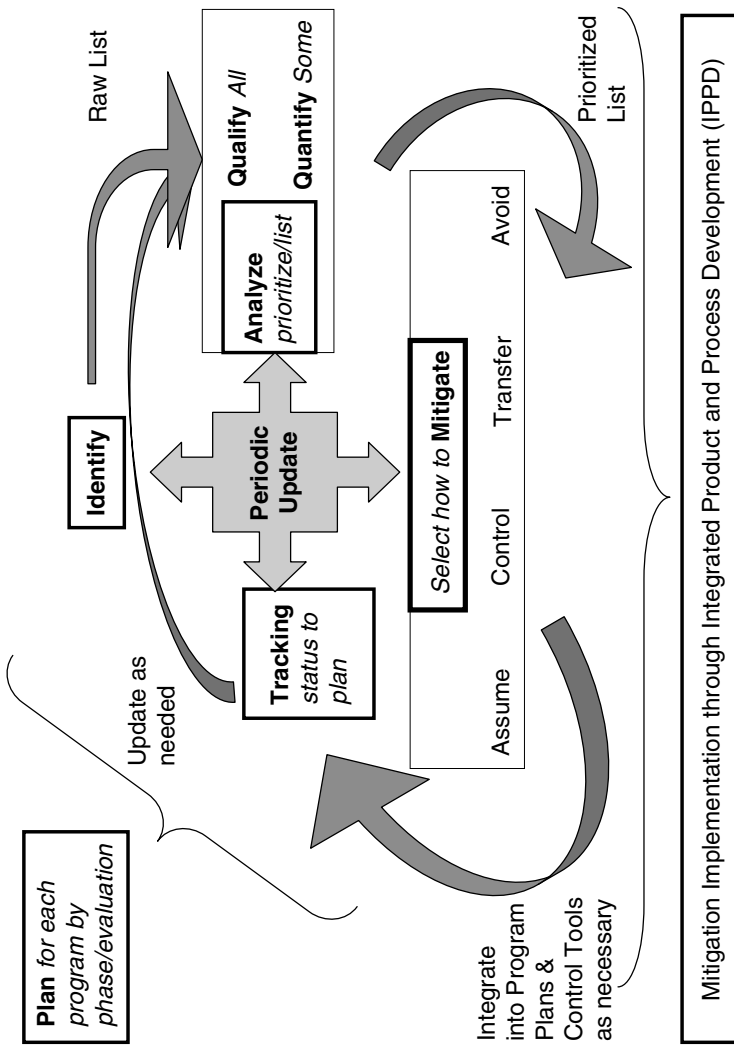

DAU PROGRAM MANAGERS TOOL KIT

# RISK AND TRADEOFF ANALYSIS

## Risk Management

### Risk Planning

Risk Management Plan  
(The Process)

<u>Risk ID</u>	<u>Risk Analysis</u>	<u>Risk Mitigation</u>	<u>Risk Tracking</u>
Technical	Networks	Avoidance	Monitoring
Cost	Simulation	Control	Reports
Schedule	Watch lists	Assumption	Feedback
Lessons learned	Templates	Transfer	T&E Results
WBS			

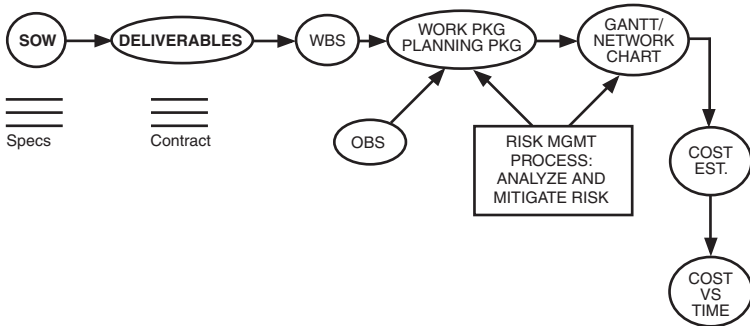

## **RISK MANAGEMENT**

1. Develop program plans to the work package level.
2. Identify and analyze risk at the lowest work package/WBS level.
3. Mitigate and actively manage the highest risk work packages; risks that you can't mitigate you must accept.

## **TRADEOFF ANALYSIS\***

1. Identify alternative solutions
2. Select evaluation criteria/factors and MOEs, i.e., cost, schedule, performance criteria
3. Weight evaluation criteria
4. Develop utility functions for each factor
5. Conduct evaluation (weighted utility summary table where weight is multiplied by utility function value)
6. Perform sensitivity check
7. Select highest scored alternative

\*With Cost As an Independent Variable (CAIV), aggressive cost objectives are established as a result of trading performance and schedule for cost.

## PROGRAM MANAGER'S CHECKLIST FOR REVIEW OF TRADEOFF PLANNING AND STUDIES

- 1. ARE ALL VIABLE ALTERNATIVES BEING EXPLORED?**
  - Is each alternative clearly defined?
  - Have the alternatives been prescreened? How?
  - Are affordability limits established?
  - Can all of the screened-out alternatives be defended?
- 2. ARE SELECTION CRITERIA IDENTIFIED?**
  - Are all significant criteria identified?
  - Do the criteria discriminate among alternatives?
  - Are the criteria measurable?
  - Have the criteria been pre-approved?
- 3. IS THE CRITERIA WEIGHTING SYSTEM ACCEPTABLE?**
  - Are rationales for criteria weights explained?
  - Are criteria weights consistent with guidance?
  - Are criteria weights consistently distributed in the tree?
- 4. ARE UTILITY (SCORING) CRITERIA DETERMINED?**
  - Is defensible rationale established for each criterion?
  - Are criteria developed from operational measures of effectiveness where possible?
  - Do all plans use the same numerical scale?
  - Is the location of the “zero point” explained?
- 5. ARE EVALUATION METHODS DOCUMENTED?**
  - Are test data reliability estimates (confidence levels) incorporated?
  - Are models validated? When? By Whom?
- 6. HAS SENSITIVITY BEEN ESTIMATED?**
  - Are error ranges carried through with worst-on-worst case analysis?
  - Have the effects of changes in the utility curve shapes been examined?
  - Have rationales for the limits been developed?

## TECHNICAL PERFORMANCE MEASUREMENT

### The Concept

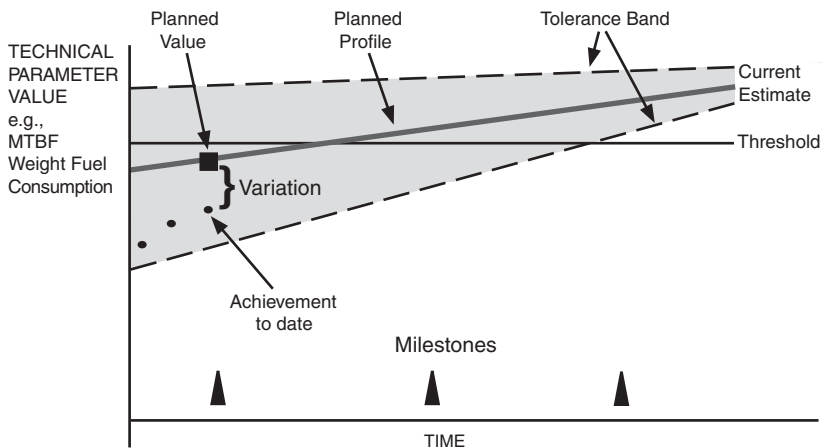

## DAU PROGRAM MANAGERS TOOL KIT

### WHAT IS SYSTEMS ENGINEERING?

- International Council on Systems Engineering (INCOSE) definition:

Systems Engineering is an **interdisciplinary approach** and means to enable the realization of successful systems. It focuses on **defining customer needs** and required **functionality** early in the development cycle, documenting requirements, then proceeding with **design synthesis** and system **validation** while **considering the complete problem...**

*Focus is on technical systems development and integrative engineering to meet requirements.*

-- [www.incose.org](http://www.incose.org)

---

### SYSTEMS ENGINEERING TASKS

- Ensure essential technical things get done
  - Verify technical solutions to satisfy customer capability requirements
  - Develop a total system design solution
    - Design in downstream life-cycle needs (open system approach)
    - Balance cost, schedule, performance, and risk
  - Generate and track technical information needed for decision making and configuration management
- 

### SYSTEMS ENGINEERING POLICY IN DoD

*(Signed by the Honorable Mike Wynne, USD(AT&L) (Acting), February 20, 2004)*

- All programs, regardless of ACAT shall:
  - Apply an SE approach
  - Develop a Systems Engineering Plan (SEP)
    - ◆ Describe technical approach, including processes, resources, and metrics
    - ◆ Detail timing and conduct of SE technical reviews
- Director, Defense Systems (DS), USD(AT&L) tasked to provide guidance for DoDI 5000.2
  - Recommend changes in Defense SE
  - Establish a senior-level SE forum
  - Assess SEP and program readiness to proceed before each DAB and other USD(AT&L)-led acquisition reviews

# SYSTEMS ENGINEERING PROCESS—TECHNICAL MANAGEMENT PROCESSES

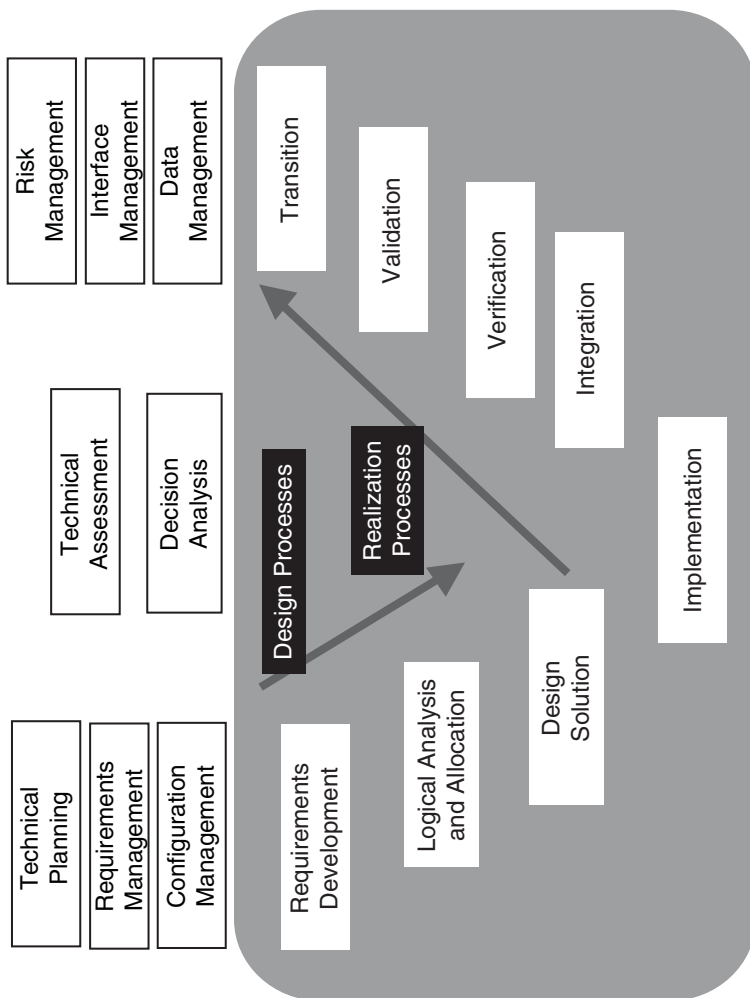

DAU PROGRAM MANAGERS TOOL KIT

**SYSTEMS ENGINEERING PROCESS LINKAGES**

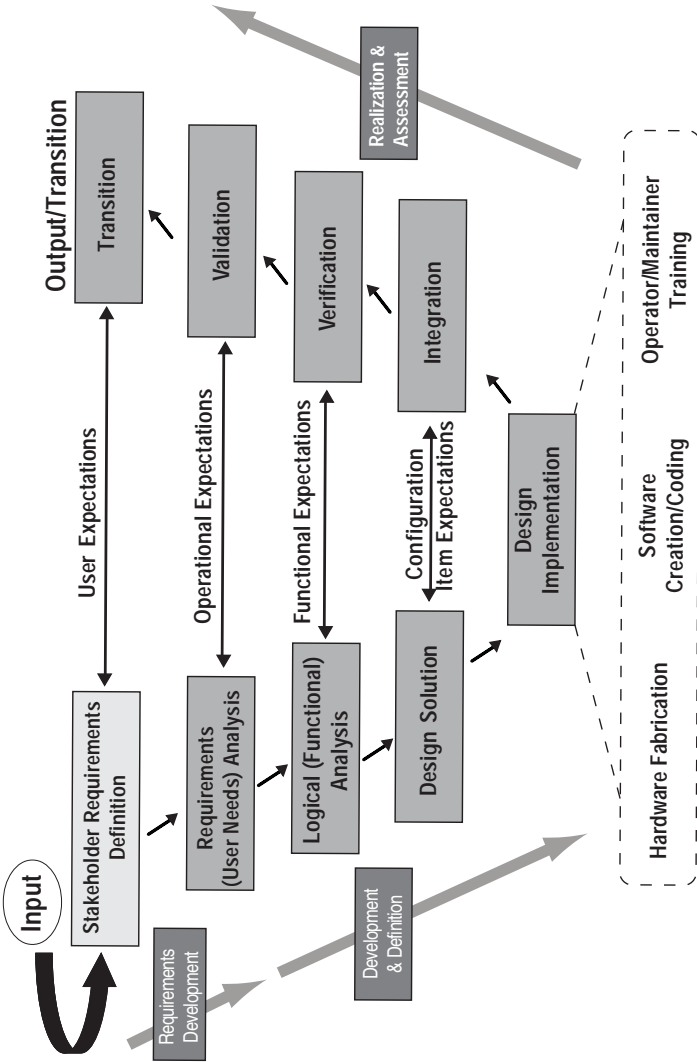

**Note:** Parts of "V" process in dark gray boxes match the Systems Engineering Process Model. This process is followed in phase activities "Vs" on succeeding pages.

# DEFENSE ACQUISITION MANAGEMENT FRAMEWORK—TECHNICAL “V” ACTIVITIES

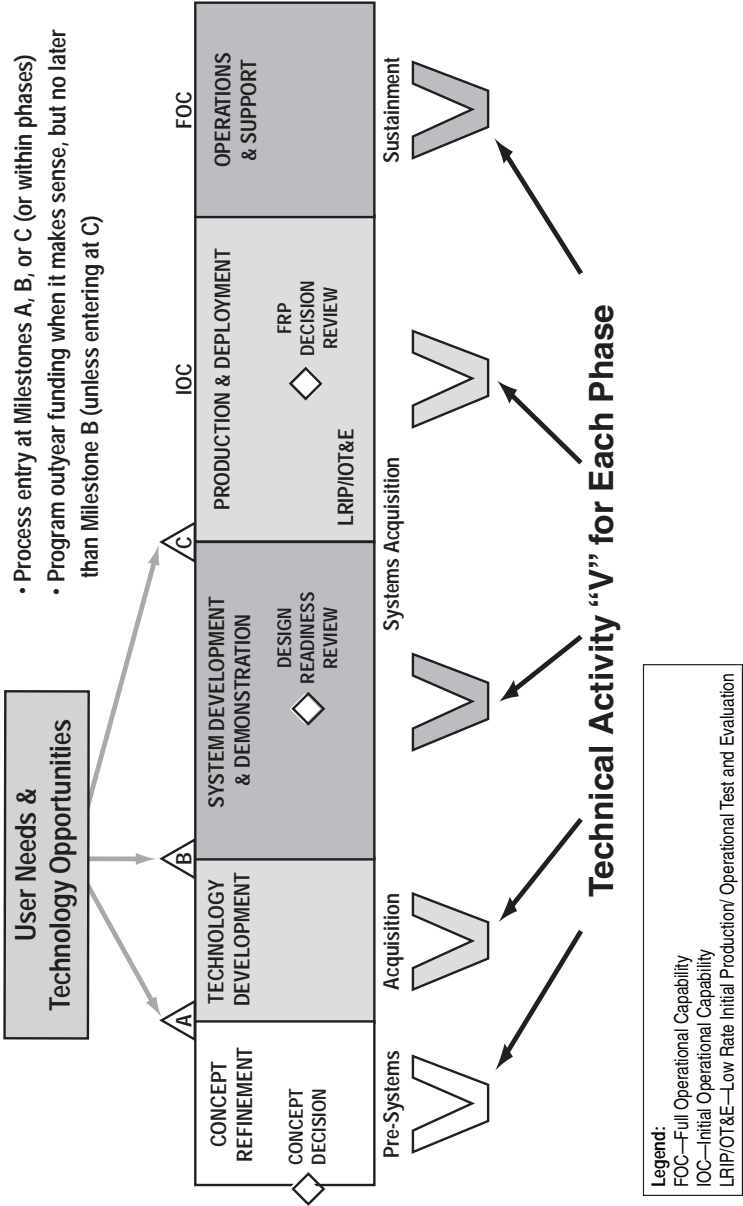

DAU PROGRAM MANAGERS TOOL KIT

**CONCEPT REFINEMENT PHASE SYSTEMS ENGINEERING (SE) ACTIVITIES**

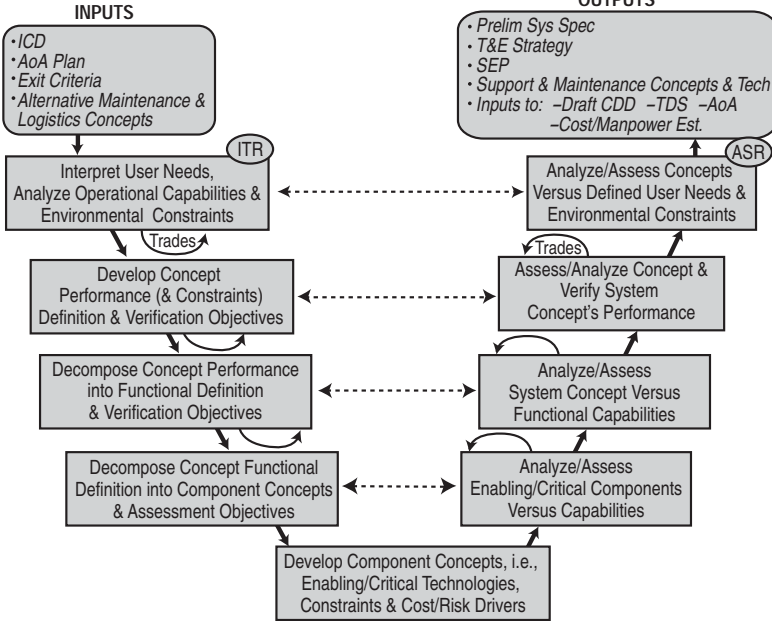

**TECHNOLOGY DEVELOPMENT PHASE SE ACTIVITIES**

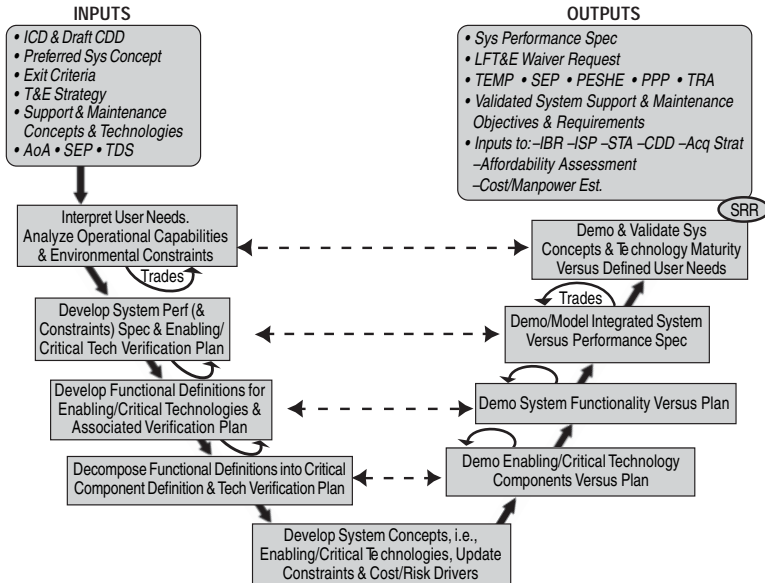

## SYSTEM DEVELOPMENT AND DEMONSTRATION PHASE SYSTEMS ENGINEERING ACTIVITIES

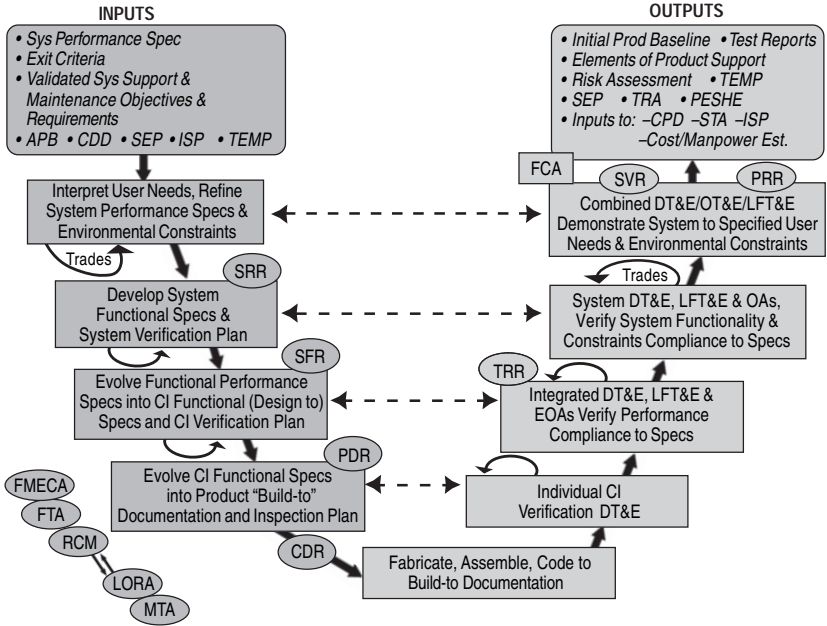

## PRODUCTION AND DEPLOYMENT PHASE SYSTEMS ENGINEERING ACTIVITIES

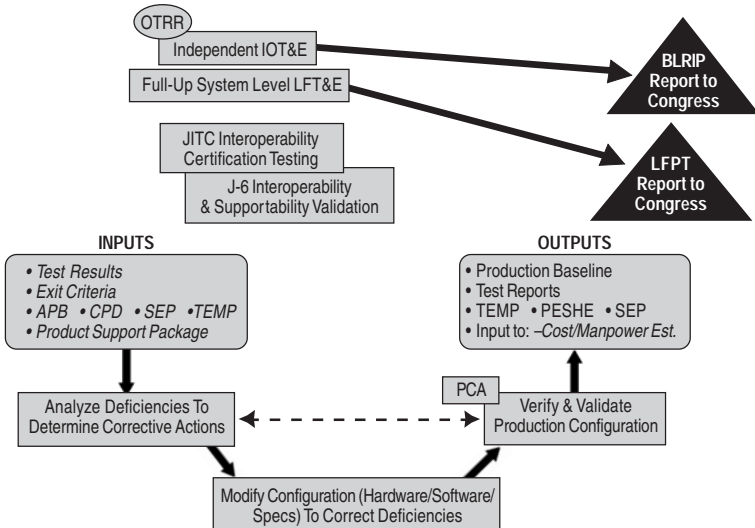

DAU PROGRAM MANAGERS TOOL KIT

## OPERATIONS AND SUPPORT PHASE SYSTEMS ENGINEERING ACTIVITIES

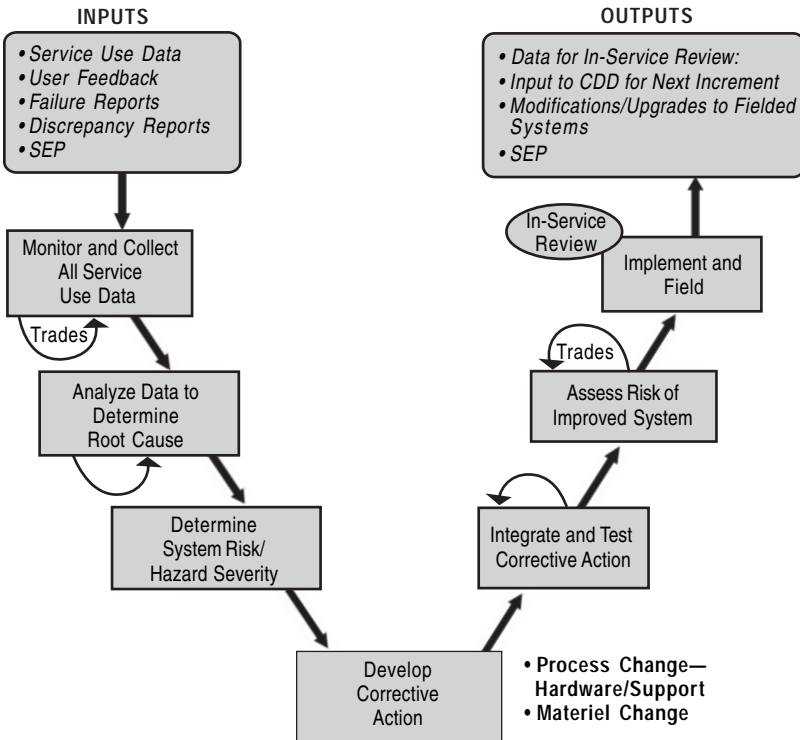

## REQUIREMENTS (USER NEEDS) ANALYSIS QUESTIONS

- What are the reasons behind the system development?
  - What are the customer expectations? How will they measure the performance of the system?
  - Who are the users and how do they intend to use the product?
  - What do the users expect of the product?
  - What are their levels of expertise?
  - With which environmental characteristics must the system comply?
  - What are existing and planned interfaces?
  - What functions will the system perform, expressed in customer language?
  - What are the constraints—hardware, software, economic, procedural – with which the system must comply?
  - What will be the final form of the product—model, prototype, mass production?
- 

## ATTRIBUTES OF A WELL-DEFINED REQUIREMENT

- **Specific, Clear, and Unambiguous:** Contains no vague terms
- **Understandable:** Stated with sufficient detail in everyday language
- **Concise:** Contains no unnecessary words
- **Consistent:** Top-to-bottom consistency with identical usage of terms and conformance to standards
- **Stable:** Baselined and under configuration control
- **Traceable:** Derived from the mission profile or the contractor's design policies
- **Verifiable:** Determine whether the product is satisfying the requirement
- **Feasible:** Can achieve, produce, and maintain the requirement

DAU PROGRAM MANAGERS TOOL KIT

# SYSTEMS ENGINEERING PROCESS— DESIGN OPERATIONS

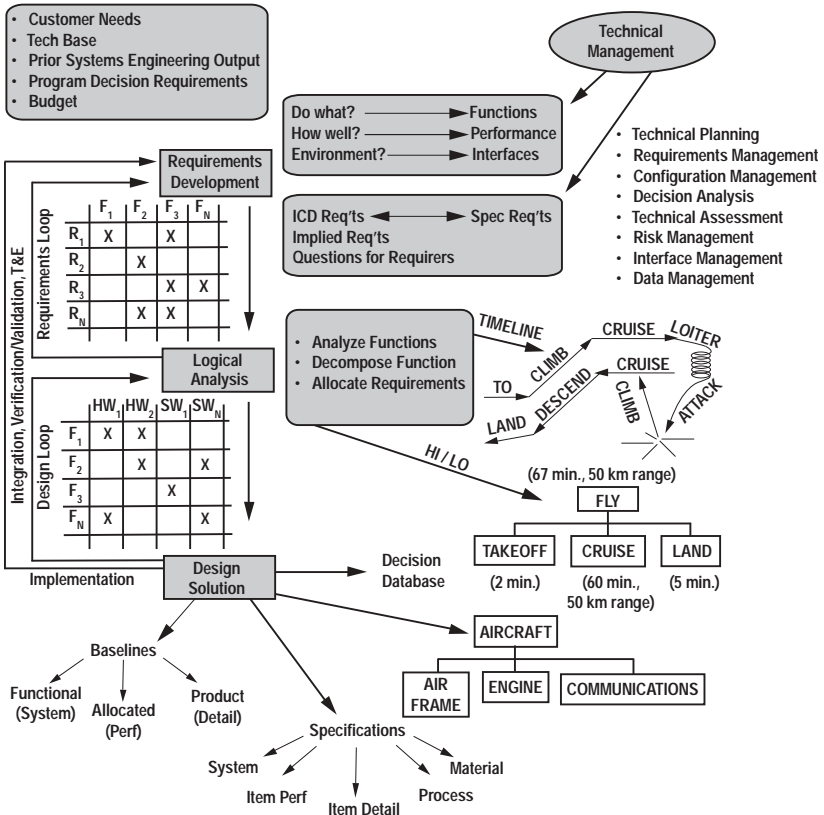

**SYSTEMS ENGINEERING DESIGN CONSIDERATIONS—“THE FISHBONE”**

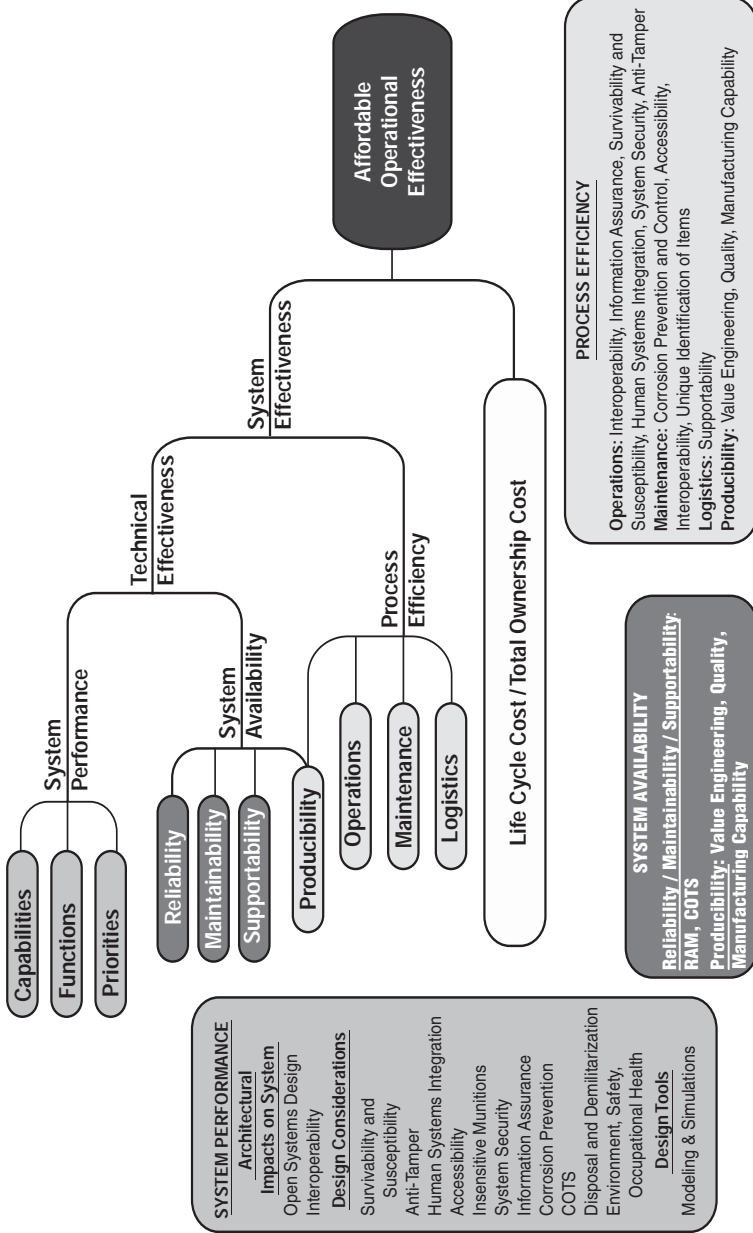

DAU PROGRAM MANAGERS TOOL KIT

**TECHNICAL MANAGEMENT PROCESSES**

(See top of Systems Engineering Process Chart, page 77.)

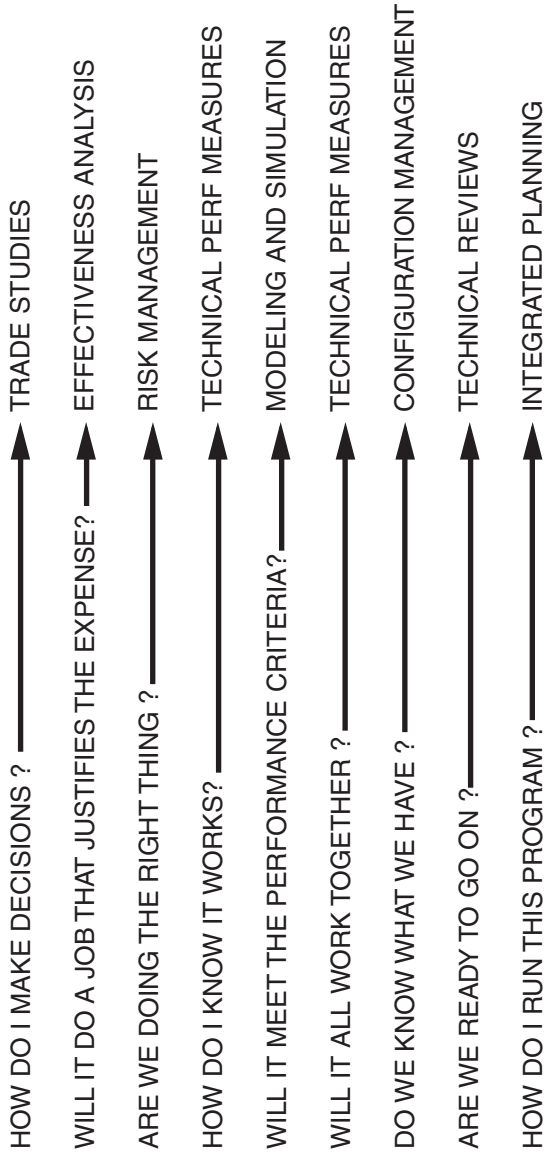

# SPECIFICATION DEVELOPMENT AND TECHNICAL REVIEWS

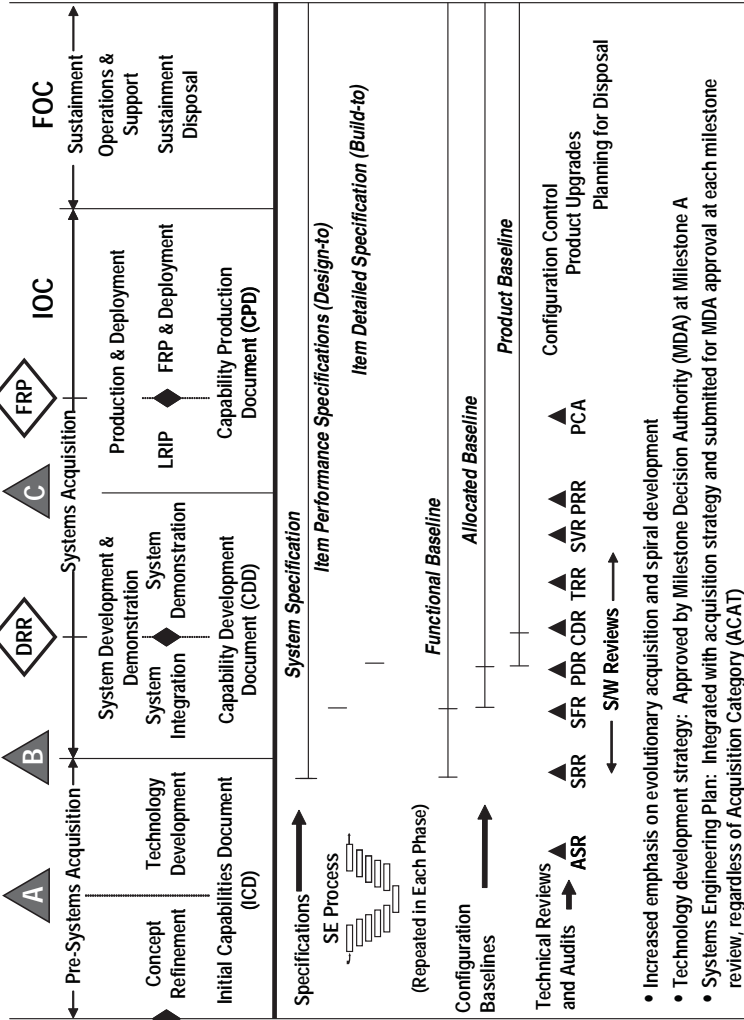

DAU PROGRAM MANAGERS TOOL KIT

## TECHNICAL REVIEW DEFINITIONS

**ASR (Alternative Systems Review)** – Assess that preferred system solution meets needs.

**SRR (System Requirements Review)** – Ensure system performance capabilities are consistent with technology solution and traceable to Initial Capabilities Document and draft Capability Development Document.

**SFR (System Functional Review)** – Ensure functional performance capabilities are consistent with cost, schedule, and risk constraints and system ready to proceed into preliminary design.

**PDR (Preliminary Design Review)** – Ensure system preliminary design and functional/allocated baseline are captured in item performance specifications for each configuration item in system.

**CDR (Critical Design Review)** – Determine that system meets stated performance capabilities, product baseline is captured in item detail specification, and system is ready for fabrication, demonstration, and test.

**PRR (Production Readiness Review)** – Verify design is ready for production and adequate production planning accomplished; system capabilities are traced to final production system.

**TRR (Test Readiness Review(s))** – Assess test readiness and approve test plans.

**SVR (System Verification Review) (synonymous with Functional Configuration Audit)** – Verify configuration items perform to specification and system is ready to proceed into Low-Rate Initial Production and Full-Rate Production within cost, schedule, and risk constraints.

**PCA (Physical Configuration Audit)** – Verify item produced (product baseline) matches design documentation (e.g., drawings, etc.) and item detail specification in the contract.

## TECHNICAL REVIEW BEST PRACTICES

*Easy in principle,  
difficult in practice.*

Technical reviews:

- Are a fundamental part of the SE process and serve as a **technical assessment product** for the program manager
  - Should be **event-based**
  - Objective entry criteria need to be defined up front
  - Are only as good as **who conducts** them
  - Engagement of Technical Authority
  - Chair independent of program team
  - Independent subject matter experts, determined by Chair
  - Involve ALL STAKEHOLDERS
- Should review **entire program from a technical perspective**
  - Cost, schedule, and performance
  - By ALL STAKEHOLDERS
  - Involve all technical products (specs, baselines, risks, cost estimates)
- Should result in program **decisions and changes**
  - Rather than a “check in the box”
- Taken as a whole series, form a major part (**backbone**) of the SEP

## DAU PROGRAM MANAGERS TOOL KIT

**SPECIFICATIONS AND STANDARDS**  
**A New Way of Doing Business (Acquisition Reform)**  
*(SECDEF Memo of June 29, 1994)*

1. Use **Performance**-Based Specifications
2. Cancel/**Convert** Manufacturing and Management Standards to **Performance** or Nongovernment Standards (NGSs)
3. Encourage Contractors to Submit **Alternative Solutions** to Military Standards/Specifications
4. **Prohibit** Use of Military Specifications/Standards **Except** when **Authorized** by Service Acquisition Executive or Designee

**PERFORMANCE vs. DETAIL SPECIFICATIONS**

	<b>PERFORMANCE</b>	<b>DETAIL / DESIGN</b>
Design/Fab.	Require desired outcomes or functions, Specific design to contractor	Specify exact parts and components
Processes	Few, if any	Specify exact processes
Physical Characteristics	Give specifics only for interfaces, environment, or human factors	Specify more physical characteristics than for interfaces, environment, etc.
Interface Requirements	Detailed interface data do NOT solely make a perf. spec. a detail spec.	Detailed interface data
Materials	Leave specifics to contractor	Require specific materials
Test and Evaluation	State performance need; contractor picks test procedure	Prescribed testing process

## PROGRAM-UNIQUE SPECIFICATIONS

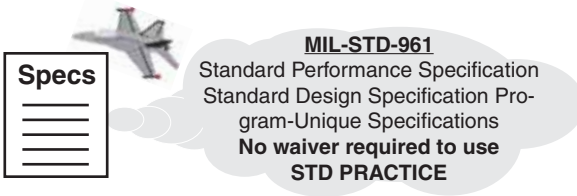

- Program unique specifications advantages:
  - Helps **avoid** duplication and inconsistencies.
  - Enables **good** estimates of necessary work and resources.
  - Provides consistent **communication** among players as people rotate.
  - Can be used to **prepare** test plans.
  - Can be used a long time **after** the system has been put into operation.
  - Serves as an **interface** between customers, developers, and designers.
- Can act as negotiation and reference document for **engineering changes**.

Specification	Content	Baseline
<b>System</b>	<ul style="list-style-type: none"> <li>• Defines mission/technical performance requirements. Allocates Requirements to functional areas. Defines interfaces.</li> </ul>	Functional (“ <b>System</b> ”)
<b>(Hardware or Software) Item Performance</b>	<ul style="list-style-type: none"> <li>• Defines performance characteristics of configuration items (form, fit, function). Details design requirements only to meet interfaces. “<b>DESIGN-TO</b>.”</li> </ul>	Allocated (“ <b>Design-to</b> ”)
<b>(Hardware or Software) Item Detail</b>	<ul style="list-style-type: none"> <li>• Includes “how to” and specific design requirements. Usually includes specific processes and procedures. “<b>BUILD-TO</b>.”</li> </ul>	Product (“ <b>Build-to</b> ”)
<b>Process</b>	<ul style="list-style-type: none"> <li>• Defines process performed during fabrication.</li> </ul>	Product
<b>Material</b>	<ul style="list-style-type: none"> <li>• Defines production of raw materials or semi-fabricated material used in fabrication.</li> </ul>	Product

## DAU PROGRAM MANAGERS TOOL KIT

### **CONFIGURATION MANAGEMENT**

**Nongovernment Standard: EIA Standard-649**

*Also see MIL HNBK 61*

**“A management process for establishing and maintaining consistency of a product’s performance, functional, and physical attributes with its requirements, design, and operational information throughout its life.”**

- **Identify** and **document** the functional and physical characteristics of configuration items.
- **Control** changes to configuration items and their related documentation.
- **Record (or Status Accounting in DoD terms)** and report information needed to manage configuration items effectively, including the status of proposed changes and implementation status of approved changes.
- **Audit** configuration items to verify conformance to specifications, drawings, interface control documents, and other contract requirements.

– Adopted by DoD on November 22, 1996

### **CONFIGURATION MANAGEMENT PLANNING**

- The decisions on
    - **Which baselines the government should eventually control**
    - **The data needed**
    - **When that control should be established**
- ... are strategic management decisions that involve
- **Acquisition strategies—sources, competition, etc.**
  - **Logistics support plans—repair levels, data needs, open systems, etc.**
  - **Technology insertion—stable vs. rapidly moving technologies, etc.**
- Government should control the Functional Baseline (document system level requirements)
  - DoD PMOs increasingly choose to leave Allocated Baselines under contractor control until late in development. (Documents the Configuration Item (CI) level design requirements.)
    - **Promotes contractor design flexibility**
    - **Relieves PMO from administrative burdens of managing design Engineering Change Proposals**
    - **Requires effective implementation of Integrated Product and Process Development**
  - When and if to control baselines is dependent on support philosophy and acquisition management strategy.

## INTERFACE MANAGEMENT

Will it all work together?

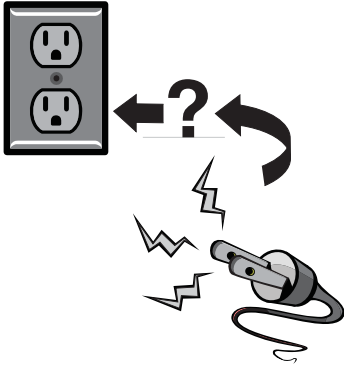

- The Government PMO:
  - Identifies external interfaces
  - Establishes interface standards (baselines)
  - Maintains interface stability
- The contractor:
  - Manages internal interfaces
  - Establishes interface requirements to include internal and external interfaces
  - Controls interfaces to ensure
    - ◆ Accountability
    - ◆ Timely dissemination of changes

*The Government increasingly chooses to manage interfaces, leaving design details to contractors.*

---

## INTERFACE CONTROL CONCEPT

- Identifies, documents, and controls all functional and physical characteristics
- Interfaces:
  - What?
    - ◆ Common boundary
    - ◆ Types: mechanical, electrical, operational, software
    - ◆ Functional and physical characteristics
  - Where?
    - ◆ Within one contractor's design
    - ◆ Among contractor's items and GFE
    - ◆ Among multiple contractors' items
    - ◆ Among systems
  - Controlled by Interface Control Working Group
  - Documented in Interface Control Documents



## SOFTWARE DEVELOPMENT—TECHNICAL REVIEW RELATIONSHIPS

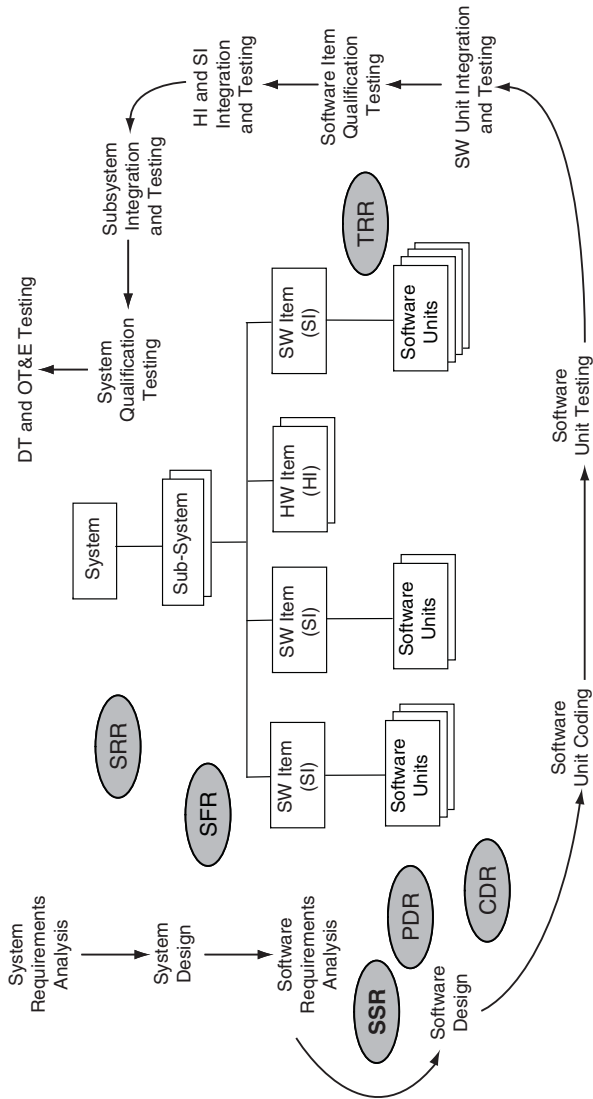

Note: SSR = Software Specification Review. The SSR is a unique sub-system review held to assess SW requirements prior to start of design.

## DAU PROGRAM MANAGERS TOOL KIT

## SOFTWARE DEVELOPMENT—KEY LIFE CYCLE REVIEW FACTORS

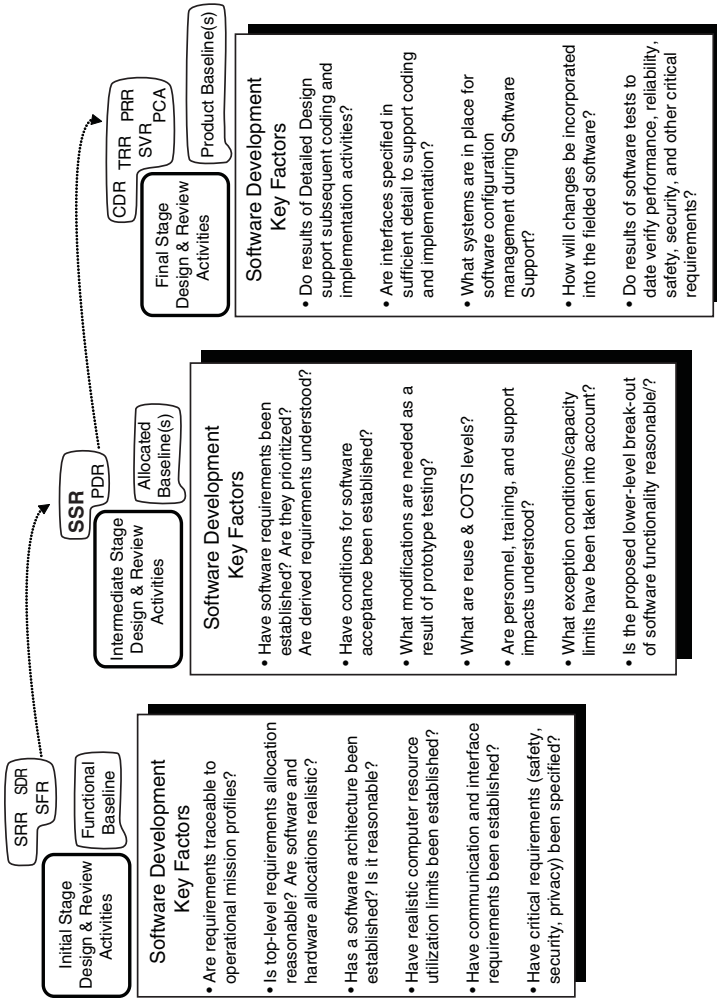

Rev 3.1

## CANDIDATE SOFTWARE MEASURES (METRICS)

- Software Size
- Requirements Volatility
- Software Effort/Staffing
- Software Progress
- Problem/Change Report Status
- Rework/Scrap
- Computer Resource Utilization
- Milestone Performance
- Build Release Content
- Software Complexity
- Effect of Reuse
- Earned Value

Software measures should be risk- or issue-driven and are phase-dependent.

Check out the handbooks at the DoD's Practical System and Software Measures site at <[www.psmc.com](http://www.psmc.com)>.

## QUALITY EVENTS FOR SOFTWARE

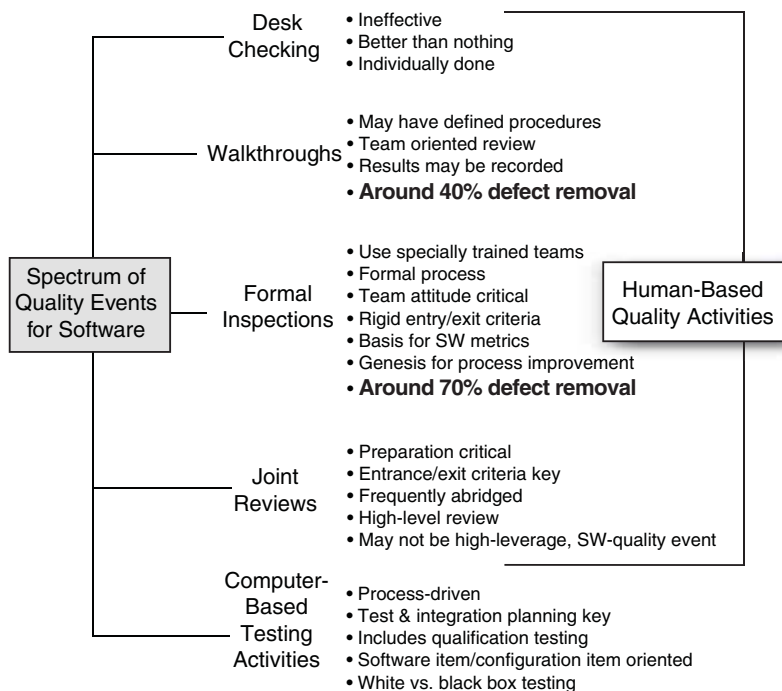

## DAU PROGRAM MANAGERS TOOL KIT

### **SOFTWARE MANAGEMENT BEST PRACTICES**

- Adopt continuous risk management
- Estimate cost and schedule empirically
- Use software metrics to help manage
- Track earned value
- Track software defects against software quality targets
- Treat people as the most important resource
- Use life cycle configuration management
- Manage and trace requirements
- Use system-based software design
- Ensure data and database interoperability
- Define and control interfaces
- Design twice, but code once
- Carefully assess reuse risks and costs
- Inspect requirements and design
- Manage testing as a continuous process
- Test frequently
- Use good systems engineering processes

---

### **SOFTWARE ACQUISITION WORST PRACTICES**

- Use schedule compression to justify new technology on a time-critical project
- Have the government mandate technological solutions
- Specify implementation technology in the RFP
- Use as many “silver bullets” as possible
- Expect to recover more than 10% schedule slip without a reduction in delivered functionality
- Put items out of project control on the critical path
- Plan on achieving more than 10% improvement from observed past performance
- Bury as much of the project complexity as possible in the software as opposed to the hardware
- Conduct critical system engineering tasks without software expertise
- Believe that formal reviews alone will provide an accurate picture of the project
- Expect that the productivity of a formal review is directly proportional to the number of attendees above five

## CHAPTER 2

# LEADERSHIP AND MANAGERIAL SKILLS

- More things that make you go “Hmmm?...”

“An authority is a person who just happens to know the source.”

“A conservative is a person who believes nothing should be done the first time.”

“Diplomacy is the art of hearing all parties arguing in a dispute and nodding to all of them without ever agreeing with any of them.”

“The meeting raised our confidence that the contractor can actually accomplish the task and that it will occur in our lifetime.”

“This is the earliest I’ve been late.”

“The world would be a much better place if people weren’t allowed to have children until they’ve proven they can successfully manage a DoD program.”

“Everyone is bound to bear patiently the results of his/her own example.”

“The superior person is firm in the right way, and not merely firm.”

DAU PROGRAM MANAGERS TOOL KIT

## MANAGEMENT AND LEADERSHIP

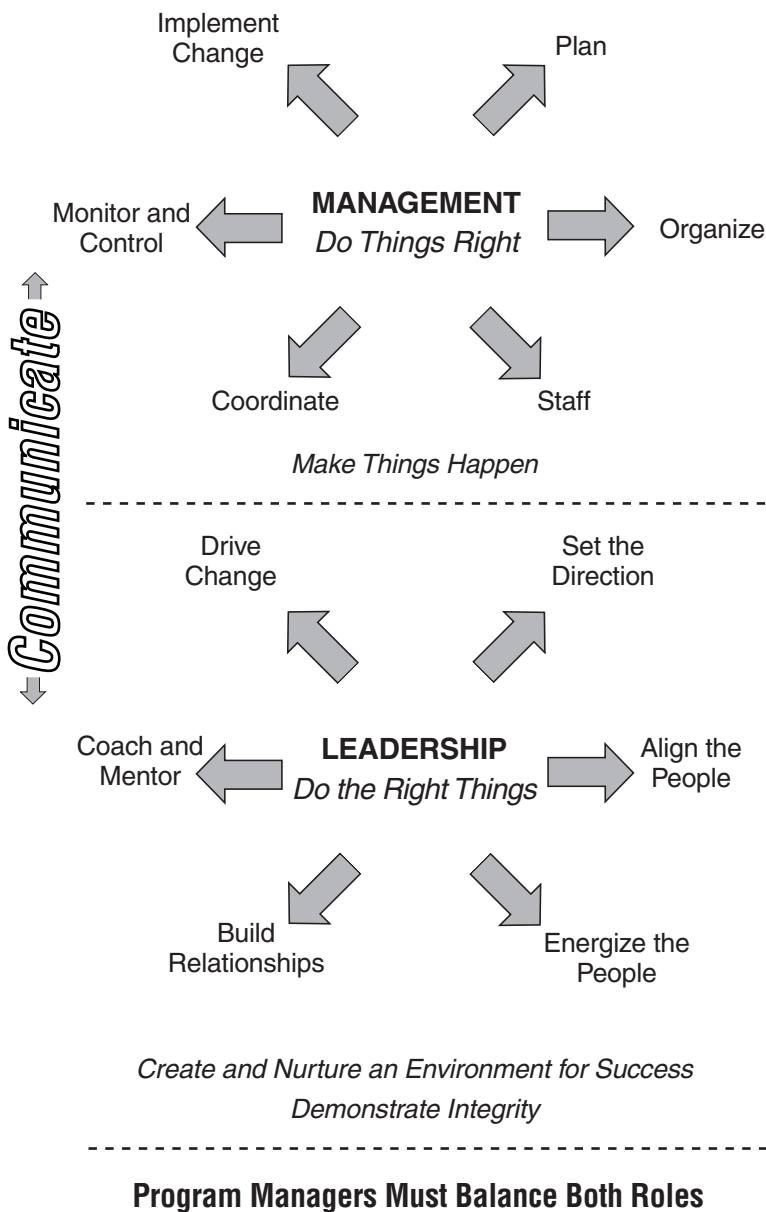

## EMPOWERMENT, DELEGATION, AND COACHING

EMPOWERMENT	DELEGATION	COACHING
Assigning an employee or team responsibility and authority to take actions and make decisions in pursuit of the organization's goals.	Assigning an employee (usually a subordinate) a specific task or tasks to complete.	Providing employees with the tools, knowledge, and opportunities they need to develop their potential and increase their effectiveness.

### Reasons for Empowerment, Delegation, and Coaching

- Allows managers more time for managerial and leadership roles (e.g., long-term planning, coordinating ongoing activities, monitoring and controlling activities, and providing feedback to employees)
- Increases employee capability and motivation
- Enhances employee career growth
- Improves teamwork
- Maximizes limited resources
- Pushes responsibility and accountability further down in the organization

### Steps for Empowerment, Delegation, and Coaching

1. Select the task or tasks to be assigned
2. Select the person or team; evaluate their current capabilities to complete the task or tasks
3. Provide training and/or coaching, if necessary, to improve their capabilities
4. Solicit input from the person or team regarding the task or tasks
5. Agree on the tasks, objectives, responsibility, authority, and deadline
6. Provide guidance, assistance, and support, as necessary
7. Establish metrics to measure progress
8. Monitor progress
9. Provide feedback
10. Identify lessons learned
11. Evaluate performance

**NOTE:** Some people use “empowerment” and “delegation” interchangeably, while others see a subtle distinction, e.g., delegation often refers to an individual, while empowerment is usually associated with groups or teams. Empowerment usually includes more authority and freedom related to making decisions and taking actions, while delegation is usually more bounded.

## DAU PROGRAM MANAGERS TOOL KIT

**EMPOWERMENT, DELEGATION, AND COACHING**

(Continued)

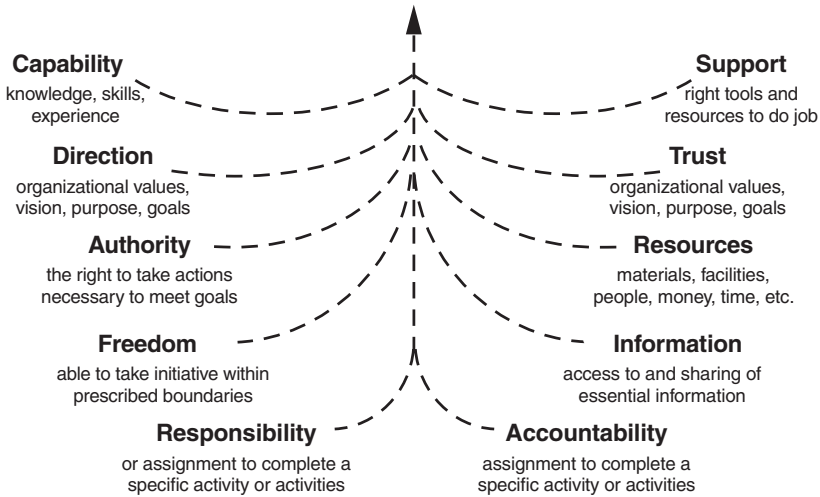

Leaders should ensure the components shown above are present.

**COACHING SKILLS**

- **Active Listening.** Give your *full attention*. Focus on the message, not formulating your response to it. Establish and maintain eye contact, paraphrase key points, and avoid making judgments.



- **Questioning.** Ask questions to promote discovery of new knowledge and stimulate thinking. Use open questions that require some thought to complete.



- **Giving Feedback.** One of the most valuable, but least used tools in communication. People are often uncomfortable giving feedback to others, particularly when they believe it could be perceived as negative. Offer factual, specific, but non-judgmental (and unemotional) feedback.



- **Sharing.** Share your experiences. Make suggestions on overcoming difficulties or how to proceed.

## GENERIC IPT PROCESS

**Identify the Need for an IPT**



**Conduct Team Closeout Activities**



**Staff the Team**



**Assess and Realign**



**Conduct Team Startup Activities**



**Develop a Plan of Action**

**Execute the Plan**



**Identify a Need for a Team**—Determine whether the creation of a team is the best method to accomplish the intended purpose.

**Staff the Team**—Determine what functional disciplines and organizations/activities need to be represented and who the team members will be.

**Conduct Team Startup Activities**—Conduct activities to get the team started, such as establishing operating agreements, assigning roles and responsibilities, and conducting team training sessions. Activities also include discussing and agreeing on the team's intended purpose, and developing shared goals, critical success factors, and metrics to measure team progress toward goals. A common output of these activities is the Team Charter. (See page 105.)

**Develop a Plan of Action**—Take specific action steps or processes for how the team will perform. This includes assigning action items, establishing target dates, determining what resources are needed, etc.

**Execute the Plan**—Perform the work necessary to accomplish the project goals and produce the team deliverables.

**Assessment and Realignment**—Conduct periodic assessments of team performance, and use metrics to measure progress toward goals. Make adjustments as necessary.

**Conduct Team Closeout Activities** – Deliver the final product or service, update program documents, and compile lessons learned.

DAU PROGRAM MANAGERS TOOL KIT

**FORMULA FOR EFFECTIVE TEAM PERFORMANCE**

**Individual Factors (Examples)**

- Personal Standards
- Personal Interests
- Personal Values
- Career Goals
- Work Ethic
- Security
- Welfare
- Morale

**Customer Factors (Examples)**

- Improved Capability
- Improved Readiness
- Reduced O&M Costs

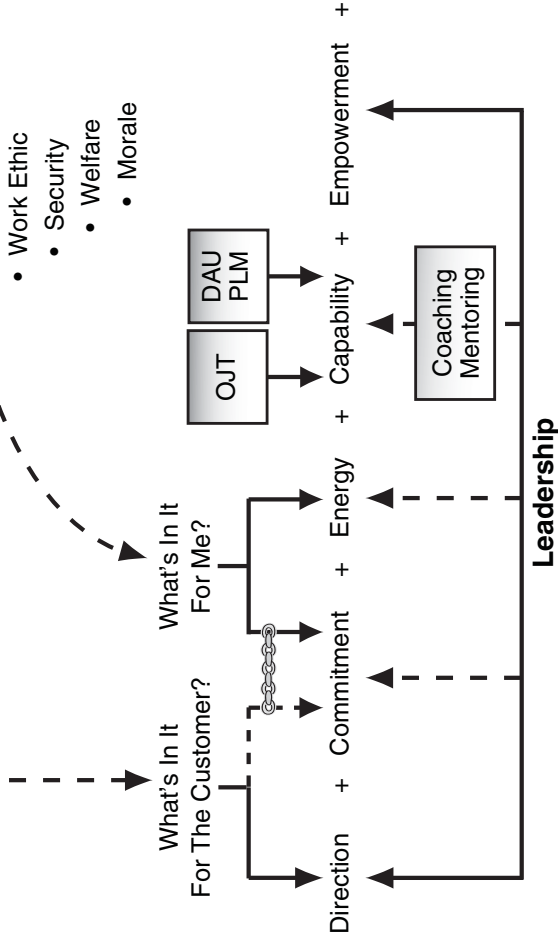
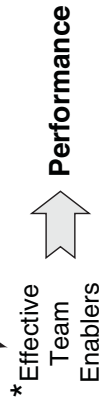
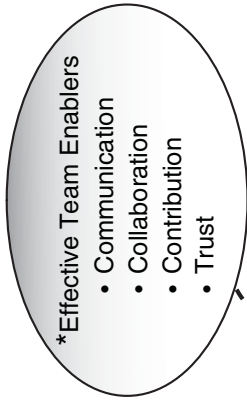

OJT = On-the-Job Training  
 DAU = Defense Acquisition University  
 PLM = Performance Learning Model

## TEAM CHARTER

**Team Charter.** A document describing key aspects of why a team is established, what is expected of it, and what authority and responsibility it has. The person or entity creating (i.e., “chartering” or authorizing) the team normally provides some general guidance; however, the team may benefit considerably by developing the “meat and potatoes” of the charter, resulting in increased commitment of all team members. Examples of topics that may be included in a charter follow:

- **Purpose.** Describe *why* the team exists and *what* it is intended to accomplish.
- **Goals/objectives.** List specific, measurable items the team is focused on achieving to help it *exceed* its customer’s expectations.
- **Critical success factors.** List the *critical actions* the team must perform to ensure it is successful in fulfilling its purpose.
- **End products/deliverables.** Describe the item(s) the team is responsible for delivering.
- **Authority and accountability.** Describe what team members are allowed/not allowed to do without authorization from a higher level. Describe what they are responsible for completing.
- **Metrics.** List measures of progress for critical success factors and goals/objectives.
- **Program schedule.** List key program/team milestones and events.
- **Team membership.** List team members and contact information.
- **Roles and responsibilities.** List specific assignments for improving team performance (e.g., time keeper, recorder or scribe, scheduler, etc.). Also, list specific tasks and/or action items the team is assigned to complete.
- **Resources required.** Describe the funding, materials, equipment, support, etc., the team needs to complete its mission.
- **Program organizational structure.** Define where the team fits within the overall program office structure.
- **Program organizational structure.** Describe or depict where the team fits in the overall program office structure.
- **Operating agreements/ground rules.** List agreed-upon guidelines describing how team members will interact, what processes they will use, and what they expect of one another.
- **Customers, suppliers, stakeholders.** List key individuals, teams, and organizations involved with the team’s output.

## DAU PROGRAM MANAGERS TOOL KIT

**WORKING GROUPS****TEAM DEVELOPMENT WHEEL**

RECOGNIZE WHICH PHASE OF TEAM DEVELOPMENT YOU ARE IN AND TAKE POSITIVE ACTION TO WORK THROUGH.

Note: There can be an additional phase—"Adjourning"—when the team disbands, says good bye, and reflects on lessons learned. This is a "celebration" phase.

This diagram is based on Dr. Bruce Tuckman's 1965 study of small groups, which identified the traditional five phases experienced by project work teams.

**TYPICAL WORKING GROUPS**

- Logistics Support Management Team (LSMT)
- Test and Evaluation Working Group (TEWG)
- Computer Resources Working Group (CRWG)
- Requirements Interface Working Group
- Interface Control Working Group (ICWG)
- Technology Assessment Working Group
- "Tiger" Team
- Process Action Team (PAT)
- Integrated Product and Process Teams (IPPTs)

## MANAGEMENT TRADEOFFS FOR WORKING GROUPS

### Advantages

- More ideas and solutions
- Consensus positions
- Strong commitments

### Disadvantages

- Takes more time
- Hard to terminate
- Paralysis by analysis

## TEAM PERFORMANCE MODEL

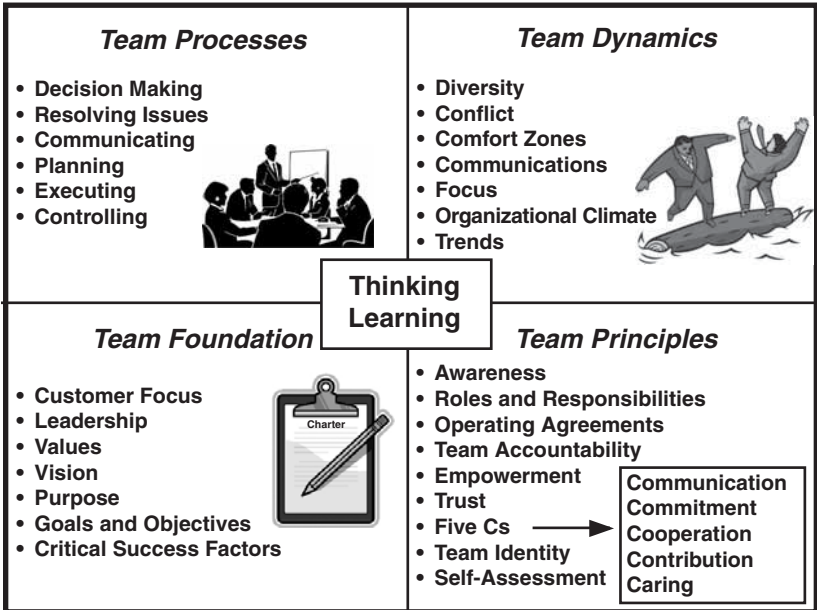

## DAU PROGRAM MANAGERS TOOL KIT

## TEAM DECISION MAKING

Good team decision making is a critical element of team performance. It involves examining the decision context (e.g., current program environment, assumptions, constraints, pressures, stakeholder inputs, etc.), determining who needs to be involved in the decision, verifying how much time is available to make the decision, and deciding on the decision-making process.

### Generally Accepted Team Decision-Making Methods

- **Unilateral.** One person makes the decision, usually the team leader.

Variations:

- *Directive or Authoritative.* The person making the decision does so primarily using his/her knowledge, experience, and program guidelines/constraints, but is also influenced by his/her own reasons and motives.
- *Consultative.* The person making the decision may seek input from other team members, but ultimately, he/she still makes the decision on his/her own.

- **Majority.** Each team member votes, and the majority decides the course of action.
- **Consensus.** Team members may not completely agree with the most preferred approach, but they have the opportunity to express their point of view, understand the logic behind the decision, and support it. Consensus is generally the preferred decision-making method for most team issues, especially when the commitment of all team members is important.

### Guidelines for Achieving Consensus:



— Don't try to force consensus. Listen to other positions and reactions before expressing your own point.



— No winners or losers. Don't assume that someone must "win" and someone must "lose" if the discussion reaches a stalemate.



— Don't avoid conflict. Don't change your mind simply to reach agreement and maintain harmony.



— Avoid majority votes, compromises, or horse trading to reach an agreement.



— It's OK to disagree. Differences of opinion are natural and expected.

**Note: Groupthink.** A phenomenon—to be avoided—where team members become so concerned about preventing disagreement or conflict that they abandon critical thinking to simply go along with whatever consensus seems to be emerging.

## EFFECTIVE MEETINGS

### Prior To the Meeting

- Determine and clarify the purpose for the meeting
- Determine expected meeting outcomes
- Identify meeting attendees
  - Subject matter experts
  - Key decision makers
  - People directly affected by potential decisions/outcomes
- Determine meeting format
  - Face-to-face, virtual teleconference, teleconference, Web tool
- Determine date/time/location
- Develop and distribute meeting agenda (at least 24 hours prior)
  - Specific topics, presenter, estimated time, desired outcome
- Meeting logistics
  - Room setup, IT support needed



### During the Meeting

- Opening
  - Start on time
  - Review agenda
  - Set or review ground rules
  - Clarify roles
- Conducting
  - Address one item at a time
  - Facilitate discussions
  - Encourage open communication and information sharing
  - Maintain focus and pace
  - Specify topics, presenter, amount of time devoted to item
- Closing
  - Summarize agreements and decisions
  - Review action items
  - Ask for agenda items for the next meeting
  - Set the date / time of the next meeting



### After the Meeting

Review and publish minutes

## DAU PROGRAM MANAGERS TOOL KIT

# DECISION BRIEFING

### Elements of a Decision Briefing

- Outline—Agenda
- Purpose of Briefing/Issue(s)
- Background
- Assumptions
- Alternatives Identified
- Evaluation Criteria/Process
- Analysis of Identified Alternatives
- Recommended Alternative
- Rationale for Recommendation
- Recommended Implementation Plan
- Key Risks for Recommended Implementation Plan



### What to Expect from the Person/People Receiving the Briefing

- Challenges to assumptions, definitions, methodology
- Questions concerning compliance with or changes to policy
- Sensitivity of the issue and/or recommended alternative to change
- Questions or challenges to analysis, tradeoffs, rationale for recommendations, and implementation plan
- Questions concerning risks for the recommended implementation plan



**NOTE:** Questions may be open-ended or closed (e.g., yes/no answers)

## COMMUNICATIONS

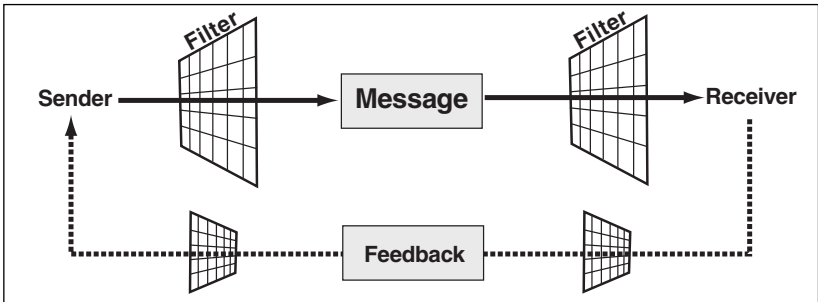

Messages pass through filters; first through the filter of the person sending the message, and then through the filter of the receiver. Filters sometimes act to enhance the message, and at other times, they can be barriers. Filters consist of factors such as personality, tone of voice, body language, facial expressions, accents, perceptions, attitudes, emotions, knowledge, functional background, the medium of communication used (verbal, written, e-mail, etc.) and much more. Each person's filter is different, sometimes resulting in the receiver interpreting the message differently than the sender intended.

One of the most important communications skills (and often a barrier to effective communications) is listening. Learning to “actively listen” can increase communications effectiveness significantly

Active listening involves:

- Establishing and maintaining eye contact.
- Focusing on what is being communicated.
- Not making judgments about the sender's information.
- Not formulating your reply before the sender has finished sending his/her message.
- Paraphrasing key points the sender makes (when the sender pauses—don't interrupt to paraphrase what's being communicated).



Effective program management requires the right people to get the right information at the right time. Program communications must take place vertically (up and down), horizontally, and externally.

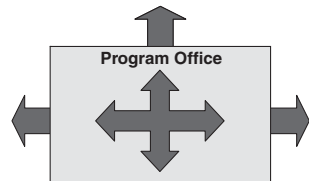

## DAU PROGRAM MANAGERS TOOL KIT

# COMMUNICATIONS\_(Continued)

### Communications Plan

One way to ensure the right people get the right information at the right times is to develop a program (and/or team) communications plan. The plan may include:

- Key entities (program management leadership, IPTs, customer, contractor(s), and key stakeholders).
- What information they should provide.
- What information they should receive.
- How it is provided/received.
- Format, frequency/interval, and other factors considered important for the particular program/situation.
- Types of meetings, such as regular status meetings and program management reviews.
- Reports (e.g., status reports, cost/sched perf reports, action item lists).
- Issues and the policy for elevating them to higher levels.
- Other forms of communication, and how and by whom they are used.



### Interpersonal Negotiation Techniques

Purpose: Resolving conflicts

Objective: Seek to satisfy both parties' interests

#### Methodology:

- Acknowledge the conflict and its effect on performance.
- Separate people and emotions from the issue.
- Present issues in terms of the underlying interests or requirements, i.e., the most important aspects of what you need to achieve.
- LISTEN to the other party's interests/requirements; be able to restate their interests to their satisfaction (indicating you understand what interests they are trying to achieve).
- Agree on what the issue is.
- Look for common goals and common interests.
- Identify as many possible alternatives to resolve the issue and satisfy the interests of both parties.
- Resist the urge to compromise ("meet in the middle"). Instead, look at the issue from different perspectives: Challenge assumptions and constraints.
- Agree on the alternative that best meets both parties' interests.
- Obtain the commitment of all members of both parties on what will be done to implement the solution.



## COMMUNICATIONS (Continued) Counseling

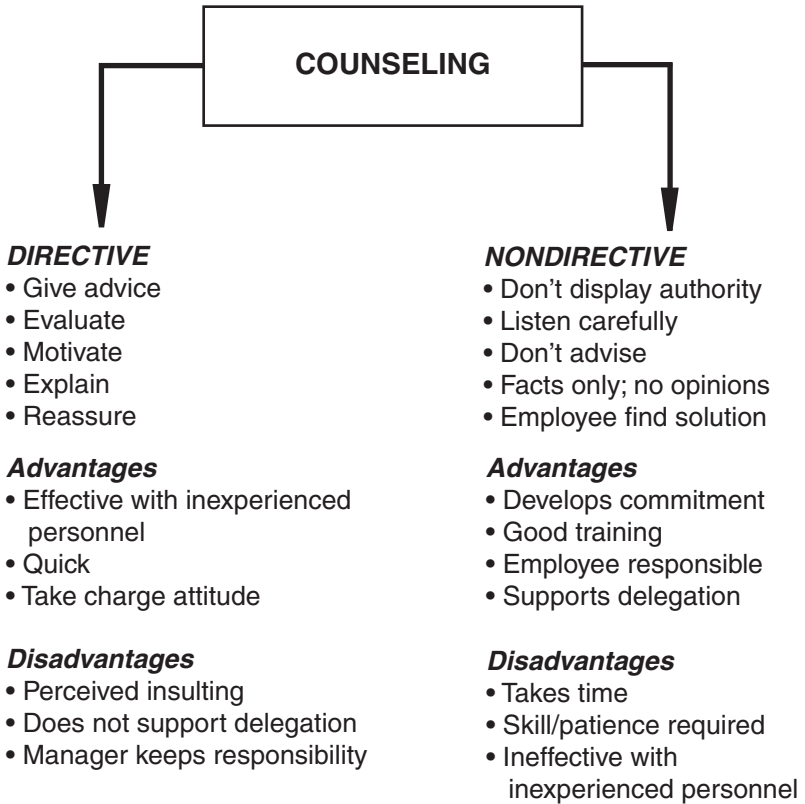

### **COUNSELING PROCESS**

1. Set up interview—private, confidential, unhurried
2. Encourage discussion—open questions, active listening
3. Help employee think it through—deal with facts, no opinions or own views
4. Let employee find the solution—his/her solution to the problem

## DAU PROGRAM MANAGERS TOOL KIT

**TIME MANAGEMENT**

1. List all the tasks you have to complete.
2. Prioritize the tasks based on urgency and importance of completion using the format shown below.
3. Do Priority 1 tasks first. If possible delegate some of them.
4. The key to effective time management is to schedule time to work on small pieces of Priority 2 tasks.  
— If not completed early, they will eventually become Priority 1 tasks.
5. Reassign or delegate Priority 3 tasks if possible.  
— A common tendency is focusing on Priority 3 tasks (because of their urgency) instead of Priority 2 tasks (because of their importance).
6. Priority 4 tasks are time wasters/busy work and should be avoided.



<b>Priority 1</b>	Important Urgent	<b>Priority 2</b>	Important Not Urgent
<b>Priority 3</b>	Urgent Not Important	<b>Priority 4</b>	Not Urgent Not Important

**Common Time Robbers****Avoidance Techniques**

- |  |   |
|--|---|
| • Incoming telephone call                  | ⇨ Screen for importance<br>⇨ Allow voice mail to pick up the call<br>⇨ Limit length of calls (e.g., 2 min.)                         |
| <hr style="border-top: 1px dashed #000;"/> |   |
| • Outgoing telephone calls                 | ⇨ Do as many at one time as possible<br>⇨ Itemize topics before calling<br>⇨ Stick to the topic; don't socialize                    |
| <hr style="border-top: 1px dashed #000;"/> |   |
| • Unscheduled visitors                     | ⇨ Screen for importance<br>⇨ Do not invite visitor into your office<br>⇨ Remain standing<br>⇨ Schedule a time for visitor to return |
| <hr style="border-top: 1px dashed #000;"/> |   |
| • Improper delegation                      | ⇨ Re-delegate<br>⇨ Make a record of delegated tasks<br>⇨ Assign deadlines   |
| <hr style="border-top: 1px dashed #000;"/> |   |
| • Poorly conducted meetings                | ⇨ Have a pre-published agenda<br>⇨ Stay focused on subject<br>⇨ Use a time keeper/gate keeper                                       |

## MANAGEMENT TOOLS AND TECHNIQUES

- 1. Activity-Based Management (ABM).** Uses detailed economic analyses of important business activities to improve strategic and operational decisions. ABM increases the accuracy of cost information by more precisely linking overhead and other indirect costs to products or customer segments. Traditional accounting systems distribute indirect costs using bases such as direct labor hours, machine hours, or material dollars. ABM tracks overhead and other indirect costs by activity, which can then be traced to products or customers.
- 2. Balanced Scorecard.** Defines what management means by “performance” and measures whether management is achieving desired results. The Balanced Scorecard translates mission and vision statements into a comprehensive set of objectives and performance measures that can be quantified and appraised. These measures typically include: financial, customer value, internal business process, learning and growth, and employee performance.
- 3. Cycle Time Reduction.** Decreases the time it takes a company or program to perform key activities throughout its value chain. Cycle Time Reduction uses analytic techniques to minimize waiting time, eliminate activities that do not add value, increase parallel processes, and speed up decision processes within an organization. Time-based strategies often emphasize flexible manufacturing, rapid response, and innovation in order to attract the most profitable customers.
- 4. Groupware.** Refers to a broad range of technologies that allow people in organizations to work together through computer networks. These products range from sophisticated electronic mail packages to applications that link offices and employees. Organizations use such technology-aided communications to better inform strategic and financial decisions and to more effectively and economically bring together working groups. (DAU has a Groupware capability in its Management Decision Center, which is used for management decision making by offices and agencies throughout DoD.)

## MANAGEMENT TOOLS AND TECHNIQUES

(Continued)

- 5. Outsourcing.** Occurs when a company or Government agency uses third parties to perform non-core business activities. Contracting third parties enables a company or agency to focus its efforts on its core competencies. Many companies find that outsourcing reduces cost and improves performance of the activity. Third parties that specialize in an activity are likely to be lower cost and more effective, given their scale. Through outsourcing, a company or agency can access the state of the art in all of its business activities without having to master each one internally.
- 6. Business Process Reengineering.** Involves the fundamental redesign of core business processes to achieve significant improvements in productivity, cycle times, and quality. In Business Process Reengineering, companies start with a blank sheet of paper and rethink existing processes to deliver more value to the customer. They typically adopt a new value system that places increased emphasis on customer needs. Companies and/or Government agencies reduce organizational layers and eliminate unproductive activities in two key areas. First, they redesign functional organizations into cross-functional teams. Second, they use technology to improve data dissemination and decision making.
- 7. Strategic Planning.** Is a comprehensive process for determining what a commercial business or Government agency should become and how it can best achieve that goal. It appraises the full potential of a business and explicitly links the business objectives to the actions and resources required to achieve them. Strategic Planning offers a systematic process to ask and answer the most critical questions confronting a management team—especially large, irrevocable resource commitment questions.

## CHAPTER 3 PROBLEM-SOLVING TOOLS

### BRAINSTORMING

**PURPOSE:** To stimulate the free flow of ideas.

**METHOD:** Group members take turns generating ideas. One idea stimulates another and then another. Freewheeling of ideas is encouraged. Brainstorming stops when all group members run out of ideas. The next page lists questions that may suggest new ideas for you.



#### GROUND RULES:

***Put prejudice aside.*** Remember, all ideas can be thought of as starters.

***No criticism allowed.*** This is not the time to judge an idea. Don't criticize other ideas no matter how ridiculous they may seem. The ideas can be discussed in detail later; at this time, the objective is to generate more ideas.

***Welcome free-wheeling or blue-skying.*** Let those wild ideas come out—otherwise you may conceal your creative process. The impractical ideas may trigger other ideas that are possible to use.

***Strive for quantity, not quality.*** The more ideas brought out, the better the chance of a great solution.

***Combine and rearrange ideas.*** Single ideas aren't the only way to make a suggestion. You can make additions or combinations of previously suggested ideas to create still better ideas.

***Record all ideas exactly as expressed.*** This keeps the mind free of remembering what was said and allows you to build on previous ideas.

DAU PROGRAM MANAGERS TOOL KIT

## **BRAINSTORMING**

(Continued)

### ***Why does it work?***

Some of the reasons why brainstorming enhances a group's creativity are that it:

- Increases involvement and participation.
- Produces the most ideas in the shortest time.
- Reduces the need to give the “right” answer.
- Frees up the group; allows the members to have fun and is interesting.
- Reduces the possibility of negative thinking.

### **QUESTIONS TO STIMULATE YOUR BRAIN CELLS:**

1. Can we use this idea elsewhere? As is? With changes?
2. If we change it, is there anything else like it? Any related issues?
3. Modify? Change? Rearrange? Meaning, color, motion, sound, odor, taste, form, shape, layout, etc.?
4. Magnify? Add what? More, stronger, larger, newer?
5. Minimize? Subtract what? Eliminate, smaller, lighter, slower, split?
6. Substitute? Who, what, when, where?
7. Reverse? Opposite, backwards, upside down, inside out?

## CAUSE-AND-EFFECT DIAGRAM

The cause-and-effect diagram is a graphical illustration of the relationship between a problem or goal (the effect) and its potential contributors (the causes). Sometimes called the “fishbone” or Ishikawa diagram.

**Used for analyzing problems, a CAUSE-AND-EFFECT DIAGRAM can help:**

- Determine root causes of a given effect; and
- Identify areas where there is a lack of data.

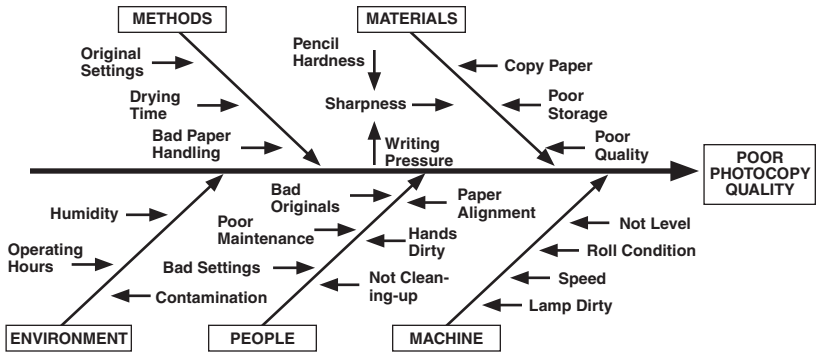

## FORCE FIELD ANALYSIS

A Force Field Analysis illustrates the relationship and significance of factors that may influence the problem or goal. This analysis helps us better understand driving and restraining forces.

### GOAL: Stop Smoking

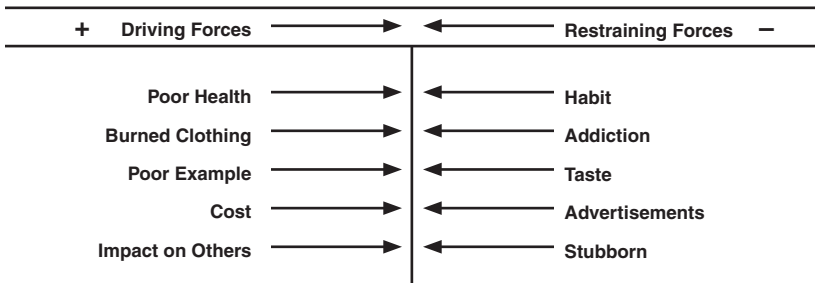

**Used for making decisions, FORCE FIELD ANALYSIS can help:**

- Identify realistic improvement opportunities;
- Develop systematic action plan for problem resolution; and
- Create criteria for evaluating effectiveness of improvement actions.

## DAU PROGRAM MANAGERS TOOL KIT

## HISTOGRAM

The histogram chart displays the distribution of a measurable characteristic (for example: weight, length, speed, etc.). A histogram shows what the variability of the data is in a graphical or pictorial manner.

**Used for data analysis, a HISTOGRAM can help:**

- Present a picture of how the process is operating;
- Compare actual process measurements with an expected distribution;
- Observe patterns in the data; and
- Investigate process stability.

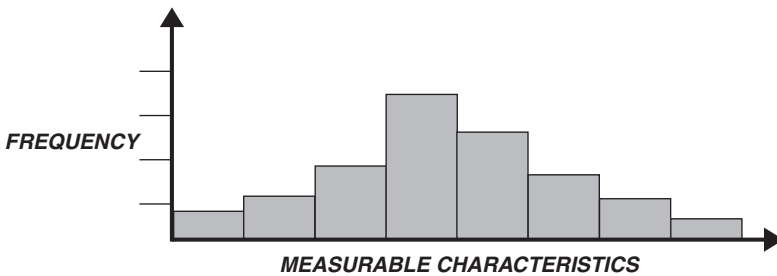

## SCATTER DIAGRAM

A scatter diagram depicts the correlation between two variables (X and Y).

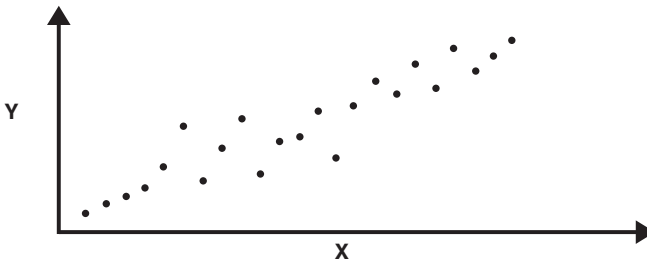

**Used for data analysis, a SCATTER DIAGRAM can help:**

- Confirm a hypothesis that two variables are related; and
- Provide both visual and statistical means to test the strength of a potential relationship.

## SURVEYS

Surveys are used to collect data from a variable number of items or people for a comparative study. They are used when a new project is planned to prove the need and the demand of the customer.

Surveys can be used anywhere in the organization to find out specific information that is necessary to make improvements in a process.

### Surveys:

- Are an inexpensive way to test a system or product
- Can be used with a large number of people or a small group
- Can give you an overall view, determined by the questions you ask
- Show if an organization is meeting its quality goals
- Help identify satisfied and dissatisfied customers or employees

### Survey Process

1. Determine the group to be studied.
2. Determine what questions will be asked.



**BRAINSTORMING**



**SURVEY**

**Note:** Train your data collectors thoroughly. Everyone must know how to ask the questions, whom to approach, and how to approach them.

3. Compile your results in chart form using a Pareto chart (see page 126), histogram, and other tools that will give you clarification.
4. Use the compounded data to form a base for improvement.
5. Continue to take data to monitor improvements, and make sure the improvements you have made are working.

### Caution!

- Data must be collected honestly and consistently.
- An untrained collector can skew the data to reflect personal biases.
- A poor, inconsistent survey will give you invalid data.
- Make sure there is enough time allowed for the collecting process.

## DAU PROGRAM MANAGERS TOOL KIT

# AFFINITY DIAGRAM

An affinity diagram is a technique for organizing verbal information into a visual pattern. An affinity diagram starts with specific ideas and helps you work toward broad categories. This is the opposite of a cause-and-effect diagram, which starts with the broad causes and works toward specifics. You can use either technique to explore all aspects of an issue.

### Affinity diagrams can help you:

- Organize and give structure to a list of factors that contribute to a problem; and
- Identify key areas where improvement is most needed.

### How to do it:

- 1. *Identify the problem.*** Write the problem or issue on a white-board or flip chart.
- 2. *Generate ideas.*** Use an idea-generation technique to identify all facets of the problem. Use index cards or Post-it® notes to record the ideas.
- 3. *Cluster your ideas (on cards or paper) into related groups.*** Use questions like “Which other ideas are similar?” and “Is this idea somehow connected to any others?” to help group the ideas together.
- 4. *Create affinity cards.*** For each group, create an affinity card, a card that has a short statement describing the entire group of ideas.
- 5. *Cluster related affinity cards.*** Put all of the individual ideas in a group under their affinity card. Now try to group the affinity cards under even broader groups. You can continue to group the cards until your definition of “group” becomes too broad to have any meaning.
- 6. *Create an affinity diagram.*** Lay out all of the ideas and affinity cards on a single piece of paper or a blackboard. Draw outlines of the groups with the affinity cards at the top of each group. The resulting hierarchical structure will give you valuable insight into the problem.

## AFFINITY DIAGRAM (Example)

A publication team wanted to reduce the number of typographical errors in their program's documentation. As part of a first step, they conducted a brainstorming session that produced the following list of factors that influenced errors.

Computers  
Proofreading Skill  
Unreasonable  
Deadlines  
Lighting  
Chair Height  
Desk Height  
Technical Jargon  
Handwriting  
Slang

Spelling  
Draft Copy  
Distribution  
Final Copy  
Computer Skill  
No Measurements  
No Feedback  
Printers  
Noise

Typewriters  
Comfort  
Time of Day  
Interruptions  
Grammar  
Punctuation  
Font  
Editing Skill  
Typing Skill

The following affinity diagram helped them to focus on areas for further analysis.

### Typographical Errors

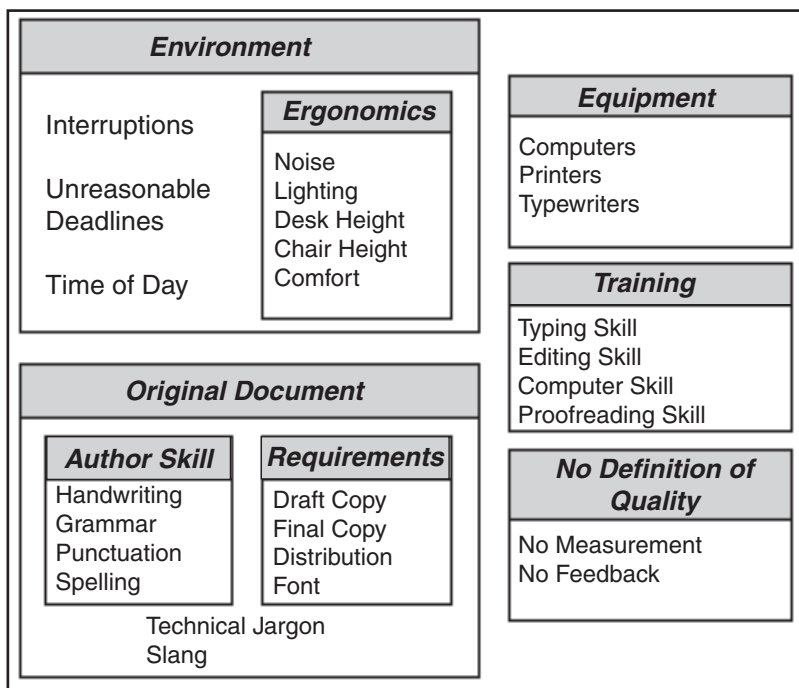

### Affinity Diagram

## DAU PROGRAM MANAGERS TOOL KIT

**PAIRWISE RANKING**

Pairwise ranking is a structured method for ranking a small list of items in priority order.

**Pairwise Ranking can help you:**

- Prioritize a small list; and
- Make decisions in a consensus-oriented manner.

**How to do it:**

1. **Construct a pairwise matrix.** Each box in the matrix represents the intersection (or pairing) of two items. If your list has five items, the pairwise matrix would look like this, with the top box representing idea 1 paired with idea 2.

	1			
2		2		
3			3	
4				4
5				

2. **Rank each pair.** For each pair, have the group (using a consensus-oriented discussion) determine which of the two ideas is preferred. Then, for each pair, write the number of the preferable idea in the appropriate box. Repeat this process until the matrix is filled.

	1			
2	2	2		
3			3	
4				4
5				

1 and 2 compared  
2 is better

	1			
2	2	2		
3	1		3	
4				4
5				

1 and 3 compared  
1 is better

	1			
2	2	2		
3	1	2	3	
4	1	2	3	4
5	5	5	5	5

...and so on  
until...

4 and 5 compared  
5 is better

## DAU PROGRAM MANAGERS TOOL KIT

3. **Count** the number of times each alternative appears in the matrix.

Alternative 5  
ranks 1st overall

Alternative	1	2	3	4	5
Count	2	3	1	0	4
Rank					

4. **Rank all items.** Rank the alternatives by the total number of times they appear in the matrix. To break a tie (where two ideas appear the same number of times), look at the box in which those two ideas are compared. The idea appearing in that box receives the higher ranking.

Alternative 5 appears  
4 times in the matrix

Alternative	1	2	3	4	5
Count	2	3	1	0	4
Rank	3rd	2nd	4th	5th	1st

## PAIRWISE RANKING (Example)

A program team was asked to recommend a site for testing a unique portion of a system. A feasibility study produced a list of six possible locations. The team then used pairwise ranking to determine that Nellis AFB was best suited for this particular test.

- |                  |                |
|------------------|----------------|
| 1. Fort Huachuca | 4. Nellis AFB  |
| 2. Edwards AFB   | 5. Eglin AFB   |
| 3. Kirtland AFB  | 6. Hanscom AFB |

	1					
2	2	2				
3	1	3	3			
4	4	4	4	4		
5	5	5	5	4	5	
6	1	6	6	4	5	

Site	1	2	3	4	5	6
Count	2	1	1	5	4	2
Rank	3rd	6th	5th	1st	2nd	4th

## DAU PROGRAM MANAGERS TOOL KIT

**PARETO CHART**

A bar chart that arranges contributing factors/causes to a problem in order with respect to their degree of contribution to the problem.

Used for analyzing problems, a Pareto chart can help:

- Select improvement opportunities;
- Identify root causes with greatest impact from a cause and effect diagram;
- Check results of improvement efforts by comparing Pareto charts before and after action is taken.

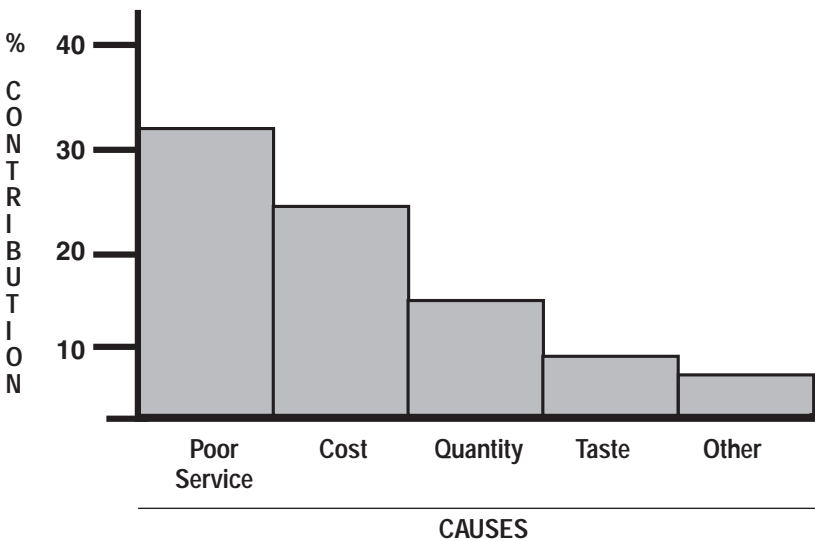
**Customer Complaints  
(Food Service)**

## BENCHMARKING

Benchmarking is the process of measuring products, services, and practices against the toughest competitors or those known as leaders in their field. Benchmarking can help you:

- Understand how you compare with similar organizations; and
- Identify areas for process improvement.

### HOW TO DO IT:

**Identify the process to be benchmarked.** Select a *process* (as opposed to a product) that is important to both your organization and your customers. Be sure the process in your organization is similar to, *and measured in the same manner as* the one to which it's being compared.

**Study other organizations.** Develop a list of organizations with comparable products and services. Determine what specific processes the organization performs. Based on this information, rank the organizations from best to worst.

**Compare and evaluate.** Compare your *process* to the best and worst cases and list the important differences. These differences can suggest potential improvements to your process.

### BENCHMARKING EXAMPLE:

Using inputs their customers provided, the executive leaders at AF Product Division B decided that their source selection process needed improvement. As part of the initial analysis, they wanted to see how their process compared with others. They determined that the average number of days required for source selection was an important process measure.

As a result of this analysis, representatives visited AF Product Division A and Navy Division B and studied their source selection procedures.

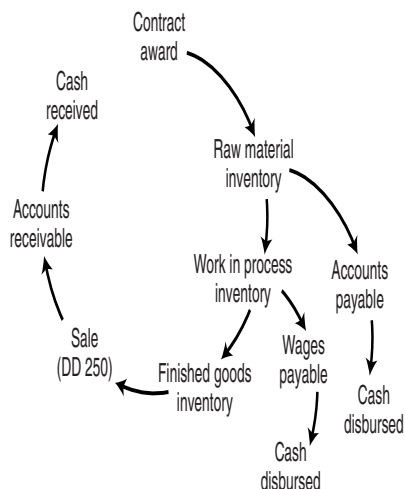

**Note:** Benchmarking is *not* replicating a process from an organization that excels (unless your goal is to be 2nd best). It *is* studying the process, clearly understanding the theory behind the process, and then restudying your own process to determine improvements.

## DAU PROGRAM MANAGERS TOOL KIT

**FLOWCHARTING**

A flowchart is a graphic representation of the steps of a process. Flowcharts help us understand the process by mapping out the steps in as much or as little detail as needed.

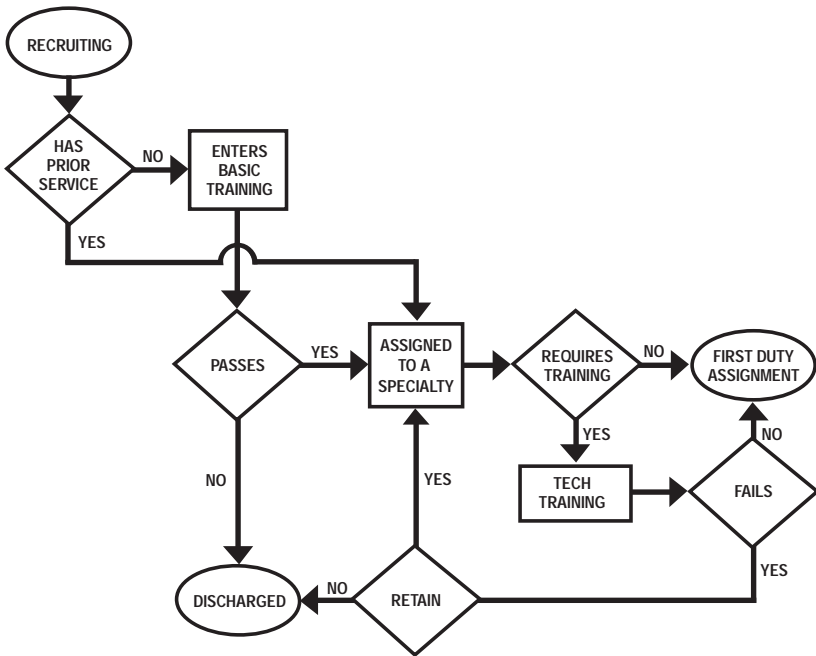



**Enlisted Accessions and Training**

***Used for analyzing a process, a FLOWCHART can help:***

- Understand the existing process;
- Locate improvement areas in a process;
- Document changes to a process;
- Show relationships between different steps in a process; and
- Identify critical stages of a process.

There are standard flowchart symbols. When you are developing a flowchart, especially in a group environment, the goal is to chart the process. Don't waste time debating which shape a symbol should be. A flowchart that doesn't use the standard symbols can be just as useful as a chart that does use them.

## STANDARD FLOWCHART SYMBOLS

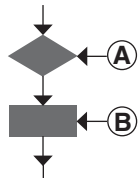
This Symbol...	Represents...	Some Examples:
	<b>Start/Stop</b>	<b>Receive Trouble Report</b> <b>Machine operable</b>
	<b>Decision Point</b>	<b>Approve/Disapprove</b> <b>Accept/Reject</b> <b>Yes/No</b> <b>Pass/Fail</b>
	<b>Activity</b>	<b>Drop off travel voucher</b> <b>Open access panel</b>
	<b>Document</b>	<b>Fill out trouble report</b>
	<b>Connector (to another page or part of the diagram)</b>	

---

## DEPLOYMENT FLOWCHARTS

A deployment flowchart shows the process flow and the work groups involved in each step. It provides a graphic representation of a given process or system work groups, or individuals responsible for each activity.

A deployment flowchart is used anytime individuals or groups need to analyze a process in order to improve a system.

## DAU PROGRAM MANAGERS TOOL KIT

**DEPLOYMENT FLOWCHARTS** (continued)

Deployment flowcharts are used for various functions such as training agenda, daily schedule, meeting analysis, emergency procedures, purchasing process, communication procedures, maintenance process, etc.

**Deployment Flowcharts:**

- Identify involvement in a process, as it relates to the whole process.
- Define work processes, and identify existing loops through people or departments.
- Visualize a process or system.

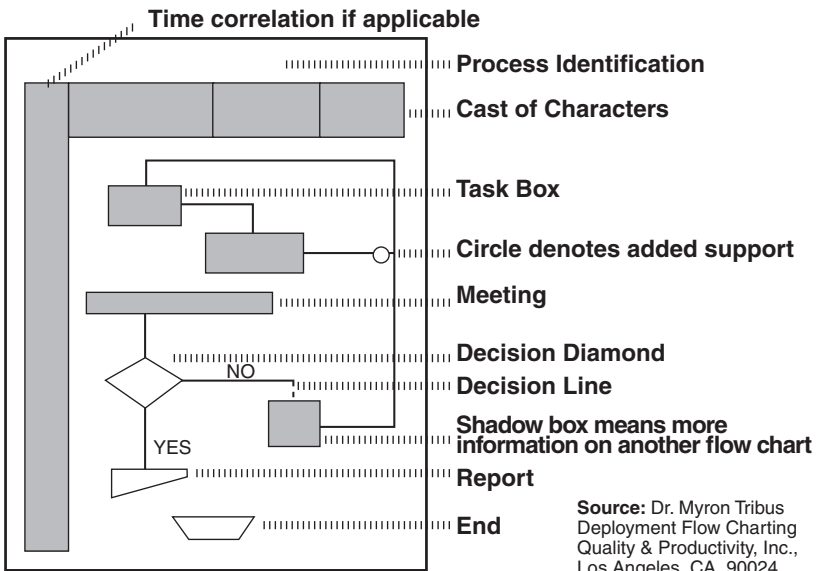
**Deployment Process**

1. Select a process or system to analyze.
2. Identify the cast of characters (people involved in the process).
3. Document the existing process using the flowchart symbols.
4. Discuss changes to be made in the process with all those involved with the process.
5. Update the deployment flowchart with the proposed changes and implement the new process
6. Study the effectiveness of the change and return to step 1 above.

## NOMINAL GROUP TECHNIQUE (NGT)

### *Ranking of consensus*

#### Why?

Allows a team to come to consensus on relative importance of issues, problems, or solutions by combining individual importance rankings into a team's final ranking.

#### What?

- Builds commitment to the team's choice through equal participation in the process
- Allows every team member to rank issues without being pressured by others
- Puts quiet team members on an equal footing with more dominant members
- Makes a team's consensus (or lack of it) visible; the major causes of disagreement can be discussed.

#### How to do it:

1. Generate the list of issues, problems, or solutions to be prioritized



In a new team with members who are not accustomed to team participation, it may feel safer to do written, silent brainstorming, especially when dealing with sensitive topics.

2. Write statements on a flip chart or white board
3. Eliminate duplicate and/or clarify meanings of any of the statements



As a leader, *always* ask for the team's permission and guidance when changing statements.

4. Record the final list of statements on a flip chart or white board

Example: Why does faculty have inconsistent output?

- A Lack of training
- B No documented process
- C Unclear quality standards
- D Lack of cooperation with other departments in developing standards
- E High turnover



Use letters rather than numbers to identify each statement so that team members do not get confused by the ranking process that follows.

## DAU PROGRAM MANAGERS TOOL KIT

**NOMINAL GROUP TECHNIQUE (NGT) (Continued)**

5. Each team member records the corresponding letters on a piece of paper and rank orders the statements

Example: Larry's sheet of paper looks like this:

A 4  
B 5  
C 3  
D 1  
E 2



This example uses "5" as the most important ranking and "1" as the least important. Since individual rankings will be later combined, this "reverse order" minimizes the effect of team members leaving some statements blank. Therefore, a blank (value = 0) would not, in effect, increase its importance.

6. Combine the rankings of all team members

	<u>John</u>	<u>Paul</u>	<u>George</u>	<u>Ringo</u>	<u>Mary</u>		<u>Total</u>
A	4	5	2	2	1	=	14
B	5	4	5	3	5	=	22
C	3	1	3	4	4	=	15
D	1	2	1	5	2	=	11
E	2	3	4	1	3	=	13

"No documented process," B, would be the highest priority. The team would work on this first and then move through the rest of the list as needed.

**Variation:*****Weighted Multivoting***

Each team member *rates, not ranks*, the relative importance of choices by distributing a value, e.g., 100 points, across the options. Each team member can distribute this value among as many or as few choices as desired.

Example:

	<u>John</u>	<u>Paul</u>	<u>George</u>	<u>Ringo</u>	<u>Mary</u>		<u>Total</u>
A	20		10			=	30
B	40	80	50	100	45	=	315
C	30	5	10		25	=	70
D		5	10		20	=	35
E	10	10	20		10	=	50

With large numbers of choices, or when the voting for the top choices is very close, this process can be repeated for an agreed-upon number of items. Stop when the choice is clear.

## CREATIVE PROBLEM SOLVING

### ***PROCESS STEPS***

1. List perceived problems
2. Gather relevant data
3. Define actual problem
4. Determine alternative solutions
5. Analyze and evaluate alternatives
6. Select solution
7. Validate solution

### ***DIVERGENT THINKING\****

1. Accept all ideas and alternatives
2. Defer judgment or evaluation
3. Discuss, combine, hitchhike, improve ideas
4. When exhausted, move to converge

### ***CONVERGENT THINKING\****

1. Establish categories of alternatives
2. Develop evaluation criteria
3. Avoid premature closure
4. Keep eye on objective
5. List strengths and weaknesses
6. Select best alternative or idea

\*Used sequentially during all problem-solving steps

DAU PROGRAM MANAGERS TOOL KIT

## KNOT CHART

**The Knot Chart is useful for:**

- Initially sorting the wheat from the chaff
- Organizing/coordinating the next steps of the problem-solving process

<b>Know</b>	<b>Need to Know</b>	<b>Opinion</b>	<b>Think We Know</b>

As you work your way through the problem, everything should move into the left column – Know.

## QUALITATIVE PROBLEM SOLVING (Kepner - Tregoe)<sup>1</sup>

Deviation Statement: (Describe the actual performance vs. should performance)

	Is	Is Not	What is distinctive about "Is" vs. "Is Not"?	Does the distinction suggest a change?
Specifying Question  What? (Identify)  Where? (Location)  When? (Timing)  Extent? (Magnitude)				
Possible Causes:				
Most Likely Cause:				

1. Define deviation.
2. Describe what deviation IS and IS NOT.
3. List distinctions between what deviation IS and IS NOT.
4. Do distinctions indicate or suggest a change?
5. Determine possible causes based on distinctions and changes.

<sup>1</sup>Copyright Kepner Tregoe, Inc. (1981). All rights reserved. Reprinted with permission. (Kepner-Tregoe, Inc., Research Road, P.O. Box 704, Princeton, N.J. 08542)

## DAU PROGRAM MANAGERS TOOL KIT

**GANTT CHART**

A Gantt Chart is used for planning schedules and managing projects. It is a method for basic planning and work instruction.

**How to do it:**

1. The Gantt Process begins by listing the activities of a project in order of execution.

<b>ACTIVITIES</b>
1. Requirements are written
2. Finances are arranged
3. Bidding takes place
4. Contractor is selected
5. Prototype is built
6. Testing begins

2. Place the number of each activity across the top of your chart. Time duration such as days, weeks, years, etc., can replace activity numbers if appropriate.
3. Draw vertical lines across the chart for each item.
4. Starting with number 1, begin comparing the activities. Can number 1 be done at the same time as number 5 or 6?
5. Draw horizontal lines to indicate which activities can be done simultaneously.

<b>ACTIVITIES</b>	<b>1</b>	<b>2</b>	<b>3</b>	<b>4</b>	<b>5</b>	<b>6</b>
1. Requirements are written	█					
2. Finances are arranged		█				
3. Bidding takes place		█	█			
4. Contractor is selected			█	█		
5. Prototype is built				█	█	
6. Testing begins					█	█

6. You now have an overview of your project giving you a starting point and time-saving measures to help you complete the project on time.