

# DATA ITEM DESCRIPTION

**Title:** AEROSPACE EMERGENCY RESCUE AND MISHAP RESPONSE INFORMATION (EMERGENCY SERVICES) SOURCE DATA

**Number:** DI-TMSS-81532A

**AMSC Number:** 7679

**DTIC Applicable:**

**Office Of Primary Responsibility:** HQ AFCESA/CEXF

**Applicable Forms:**

**Use/relationship:** This information is used as source data for the preparation and maintenance of Technical Order (TO) 00-105E-9, *Aerospace Emergency Rescue and Mishap Response Information (Emergency Services)*. This DID contains the format and content preparation instructions for the data product generated by the specific and discrete task requirement as delineated in the contract. Additionally, required changes for text and illustrations are explained.

a. This DID is applicable to the acquisition and modification of all aircraft, helicopters, unmanned aircraft vehicles (UAV) and aircraft systems that are to be used by the Department of Defense military services and require fire protection and emergency rescue information to include NASA, Civil Reserve Air Fleet, and various US Government agency aircraft.

b. TO 00-105E-9 is primarily used by firefighting personnel to identify internal and external hazards/HAZMAT, gain entry, shutdown systems, and rescue aircrew and passengers in the event of an aircraft accident. It is additionally utilized by secondary response situations confronted by Bioenvironmental engineers, accident investigation teams, secondary emergency responders, explosive ordnance disposal (EOD) and aircraft crash recovery crews in the performance of their duties.

c. The procedures and methodologies in the TO are used by Fire Department aircraft fire fighting training programs for installation assigned aircraft.

d. This DID supercedes DI-TMSS-81532, Aircraft Emergency Rescue Information (Fire Protection) Source Data, dated 970124. Title of TO was changed and more requirements have been added making this revision necessary bringing it in line with its current use and methodologies.

## Requirements:

1. Reference Documents. The applicable issue of the documents cited herein, including their approval dates and dates of any applicable amendments, notices, and revisions, shall be as specified in the contract.

2. Format. Source Data contractor format is acceptable. Abbreviations and acronyms shall be kept to a minimum and be in accordance with MIL-STD-38784. MIL-STD-38784 may be obtained from the Standardization Documents Order Clerk, 700 Robbins Avenue, Building 4D, Philadelphia, PA 19111-5094.

3. Content. The content of the information shall be presented in the style of the technical manual specified in the contract. Text is typewritten and single spaced. Illustrations shall be presented in textual descriptive form, marked-up illustrations, marked-up photographs, or existing TM drawings with appropriate text describing intent of drawing.

3.1 Preparation Instructions. The source data shall include the following:

3.1.1 System Coverage. All aircraft, helicopters, UAVs, or aircraft systems that are to be used by the Department of Defense and require fire protection and emergency rescue.

3.1.2 Illustrations. (See figures 1 - 13) Illustrations needed in conjunction with this data are extracted from existing Technical Manuals (TM) or engineering drawings that are developed for the aircraft or system being acquired. Digital photographs are also acceptable. Illustrations are created only when existing illustrations, found in the relevant TMs and engineering drawings, cannot satisfy the requirements of this DID. The following apply to illustrations:

a. Illustrations are in accordance with MIL-STD-38784 with the exception that they do not have figure numbers and color is used as described in 3.1.3.

b. Illustrations are turned 90 degrees counterclockwise (landscape - see all figures).

c. Each type and model aircraft is orientated to a computer screen instead of a standard left-hand page.

## DI-TMSS-81532A

## Item 3.1 PREPARATION INSTRUCTIONS (Continued)

- d. This manual is prepared in electronic media and is published in PDF format posted to an authorized web site.
- e. The official military or commercial aircraft designations, such as F-22A, F-117A, C-17, and B-2, are positioned in the upper right corner.
- f. The page number at the upper left is rotated 90 degrees clockwise and is associated with the aircraft such as C-17.1, B-2.9, and F-15.4.
- g. A list of special tools and equipment required is boxed in the upper left corner of the Aircraft Entry page of each type and model of aircraft (see Figures 7 and 8).
- h. Aircraft entry and model designation (such as C-17A, B-52) is as depicted (see Figures 7 and 8).
- i. Illustrations are coordinated with text by showing applicable paragraph numbers (see Figure 8).
- j. Aircraft dimensions, height, length, and wingspan, are depicted in a 3 view graphic (see Figure 2).
- k. Aircraft recognition is illustrated by an Aircraft Paint Scheme page with a current picture of the aircraft (see Figure 1).

3.1.3 Color in illustrations. Other colors may be used to prevent confusion when areas overlap or a unique system or component is used. The following items are depicted on appropriate illustrations and are colored using the following guidelines:

- a. Fuel systems - blue.
- b. Oxygen systems and cut-in areas - yellow.
- c. Armament (interior and exterior) - red.
- d. Battery (main and auxiliaries) - black.
- e. Hydrazine - purple.
- f. Nitrogen systems - orange.
- g. Ammonia - green.
- h. Hydraulic systems - brown.
- i. Oil and reservoirs - light brown
- j. Composites materials - various (with legend)
- k. Emergency and normal entry details:
  - (1) Emergency releases (interior and exterior) - red.
  - (2) Ejection handgrips - red.
  - (3) Jettison handles (canopies, doors, and hatches) - red.
  - (4) Ejection catapult safety pins with streamers - red.

NOTE: These details may also be red/black or yellow/black showing actual colors.

## DI-TMSS-81532A

## Item 3.1 PREPARATION INSTRUCTIONS (Continued)

## l. Engine shutdown details:

- (1) Fire shutdown switches - red.
- (2) Fire suppression system handles - red.
- (3) Power and battery switches - red.
- (4) Throttle levers - red.
- (5) Fuel selector switches - red.
- (6) Mixture levers - red.
- (7) Auxiliary Power Unit (APU) switches - red.

## m. Ejection seat details:

- (1) Firing handles/triggers - red.
- (2) Arming levers - red.
- (3) Safety pins and streamers - red.
- (4) Initiators, thermal batteries, pyrotechnic devices, and shield mild detonating cord - red.
- (5) Rocket catapult and other seat mounted rockets - red.
- (6) Initiator hose quick disconnects - red.

## n. Aircrew extraction details:

- (1) Restraint belts - red.
- (2) Releases for restraint belts, harnesses, straps and handles, survival kits - red.
- (3) Personal service quick disconnects - red.

## o. Skin penetration point/fire access door details:

- (1) Skin penetration - red or broken red line
- (2) Fire access doors - red or broken red line

3.1.4 External hazards. (see Figures 3 and 4) Illustrations and information for all external hazards such as emitting radar zones, approach areas to engine intakes and exhausts, propeller clearances, ejected seat and jettisoned canopy envelopes with associated shrapnel danger areas, spin and drag chute ignitors or cartridges, armament firing zones, hot brakes, engine starting cartridges, APU exhaust ports, flare tube outlets, chaff dispensing units, etc. These areas are depicted as a shaded area or with broken lines.

3.1.5 Fuel system (internal hazards). Illustrations and information for fuel systems, including fuel tanks, that are internally hazardous such as interconnecting lines with fuel tanks, etc., (see Figures 7 and 8).

3.1.6 Composite material hazards. Illustrations and information for areas containing composite materials and types (organic, inorganic, or both) which would create additional hazards in a fire. This information includes burn potential flash points of the composite materials and any environmental risks (see Figure 5).

## DI-TMSS-81532A

## Item 4 PREPARATION INSTRUCTIONS (Continued)

3.1.7 Aircraft dimensions. Illustrations and information for aircraft dimensions with landing gear in down position, (i.e., height, width, and length as a minimum). This information includes interior cubic footage to determine fire retardant agent usage and amount (see Figure 2).

3.1.8 Cockpit or flight deck. Illustrations and information for the cockpit or flight deck including controls for engine and APU shutdown (see Figure 10).

3.1.9 Cabin arrangement or configuration. Illustrations and information for cabin layout, crewmember and passenger configurations, capacity, and any possible locations outside the normal seating arrangements, i.e., galley, latrine, equipment, and maintenance areas or bays, etc., (see Figure 12).

3.1.10 Escape and ejection systems. Illustrations and information for escape and ejection systems employing pyrotechnics and their associated hazards. This information includes the safeing of such systems and required disconnection (e.g., oxygen and communication leads, etc.) enabling successful aircrew extraction and rescue (see Figure 11). General information about these systems are explained in Chapter 2.

3.1.11 Restraint devices. Illustrations and information for seats employing restraint devices and procedures for releasing occupants from the seats, including positioning levers, (i.e., inertial reel control, vertical, horizontal, tilt, and pedestal controls for shifting the seat forward or aft) (see Figure 11). General information about these systems are explained in Chapter 2.

3.1.12 Skin penetration points. Illustrations and information for skin penetration points and their dimensions for all potential fire areas. A broken line illustrates each area for skin penetration (see Figure 6).

3.1.13 Window cut-in areas. Illustrations and information for locations and dimensions of cut-in areas around all aircraft windows and their internal operation, if applicable (i.e., sliding open with associated controls, etc.). A broken line illustrates each area for cut-ins (see Figure 9).

3.1.14 Flotation equipment. Illustrations and information for the controls, locations, and use of flotation equipment deployment systems and any associated hazards during deployment. This information includes location and procedures for escape for overhead openings and hatch openings requiring ropes or ladders after deployment.

3.1.15 Fire extinguishers. Illustrations and information for fire extinguisher locations, capacities, and types of extinguishing agents.

3.1.16 Engine fire bottles. Illustrations and information for engine fire bottle (if any) locations, capacities, and types of extinguishing agents.

3.1.17 Oxygen systems. Illustrations and information for locations, capacities, and number of oxygen regulators, shutoff valves, and cylinders or bottles in the system (see Figures 7 and 8).

3.1.18 On Board Inert Gas Generating System (OBIGGS) and like systems as they are developed. Illustrations and information for any OBIGGS, as well as locations and capacities of nitrogen cylinders, and location of panel switches that control these systems (see Figures 7 and 8).

3.1.19 Hydraulics. Illustrations and information for locations and capacities of hydraulic fluid reservoirs and lines. This information is normally depicted on the aircraft entry page.

3.1.20 Hazardous materials. Illustrations and information for the material, health hazard, first aid treatment, fire hazard, location, and amount. (Details of these materials are either placed in specific aircraft files and/or fully explained in Chapter 3.)

4. Special Tools and Equipment. Tools and equipment required for fire protection and emergency rescue specific to each aircraft. If any tools must be locally manufactured, this information includes complete instructions for fabrication of the tool such as parts required, procedures for fabrication and treating, special processes, etc., (see Figure 13).

DI-TMSS-81532A

5. Required Changes and Updates. Required changes and updates shall contain a separate package supporting the change. If more than one package of changes is submitted, the contractor shall divide the packages enabling the publications personnel to readily identify them. The packages shall be titled "Changes Required in Technical Manual 00-105E-9, Revision Number \_\_\_\_\_, Book Dated \_\_\_\_\_, Changes Dated \_\_\_\_\_."

5.1 Each page of each package shall be identified with the applicable technical manual number. An introductory statement in each package shall identify any modifications for this technical manual that are incorporated.

5.2. The source data shall contain essential information that will enable publications personnel to accomplish all required technical manual changes. When an illustration which is used in more than one technical manual has been changed, the publications personnel shall be informed of this illustration change which shall be incorporated in the source data for this technical manual.

6. Text Changes. Each recommended technical manual text change shall be identified and as closely associated by the relevant page, paragraph and sub paragraph number listed in the technical manual. New paragraphs and sub paragraphs to be added shall be identified and contain the essential information that will enable publications personnel to accomplish the change.

7. Illustration Changes. Illustration changes shall be identified by the relevant page, paragraph and sub paragraph of the technical manual. New illustrations to be added shall be identified and as closely associated by the relevant page, paragraph and sub paragraph of the technical manual. When illustration changes consist of only nomenclature or call-out changes, these changes may be identified by a textual description of the change(s) to be made.

8. End of DI-TMSS-81532A

F-22A.1

# AIRCRAFT PAINT SCHEME

# F-22A

Item 10, PREPARATION INSTRUCTIONS  
T.O. 00-105E-9

DI-TMSS-81532

6



FIGURE 1. Example of aircraft paint scheme.

F-117A.2

# AIRCRAFT DIMENSIONS

# F-117A

Item 10, PREPARATION INSTRUCTIONS  
T.O. 00-105E-9

DI-TMSS-81532

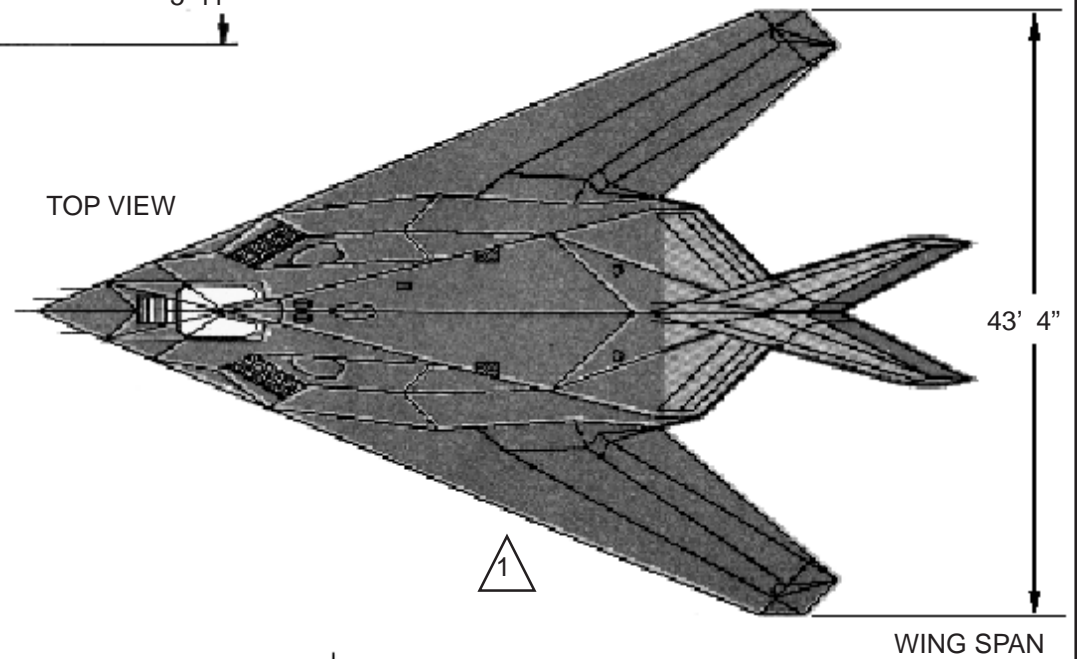
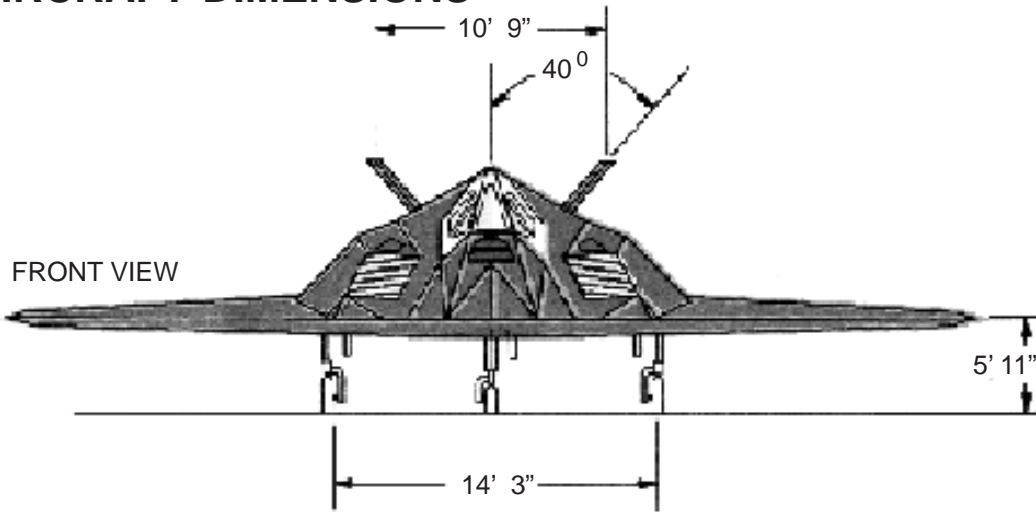

NOTE:  
 1 Dimension shown (side view) is for nose and main gear struts inflated to 3 inch extension.

LEFT SIDE VIEW

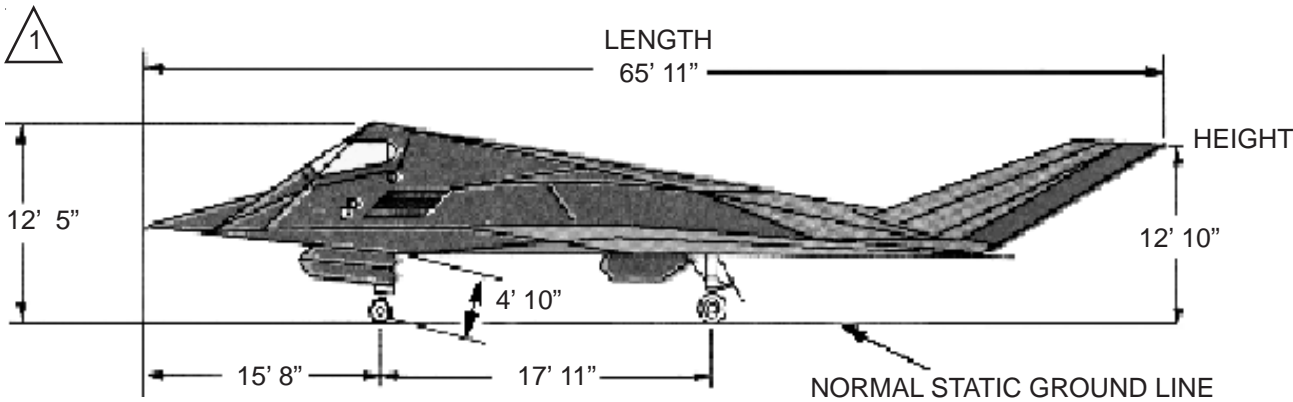

FIGURE 2. Example of aircraft dimensions.

# DANGER AREAS

C-17A

## WARNING

Engines, at any power setting are capable of developing enough inlet duct suction to cause fatal injuries to a person too close to the inlet.

## CAUTION

When loading or unloading personnel, baggage, or equipment through the crew entry door, with engines operating, stay clear of engine inlets. Secure all loose personal items before passing in front of operating engines. Application of high power settings with jet blast directed toward the path of other aircraft is not recommended. Jet blast is cumulative with surface winds and may exceed the operating limits of other aircraft.

NOTE:

If winds exceed 25 knots or ramp surfaces are slippery, add 50% to distance at intake.

### LEGEND

RADAR:

 RADIATION 48 FT RADIUS

TAKE OFF THRUST:

 INTAKE  
16 FT RADIUS

 BLAST (TWO ENGINES)  
283 MPH AT 115 FT OR LESS  
167 MPH AT 170 FT  
69 MPH AT 338 FT  
27 MPH AT 1100 FT  
20 MPH AT 1400 FT

 TEMPERATURE:  
200 DEGREES AT 65 FT  
150 DEGREES AT 95 FT  
100 DEGREES AT 202 FT

IDLE THRUST:

 INTAKE  
9 FT RADIUS

BLAST  
136 MPH AT 28 FT  
68 MPH AT 95 FT

TEMPERATURE  
125 DEGREES AT 22 FT  
100 DEGREES AT 50 FT

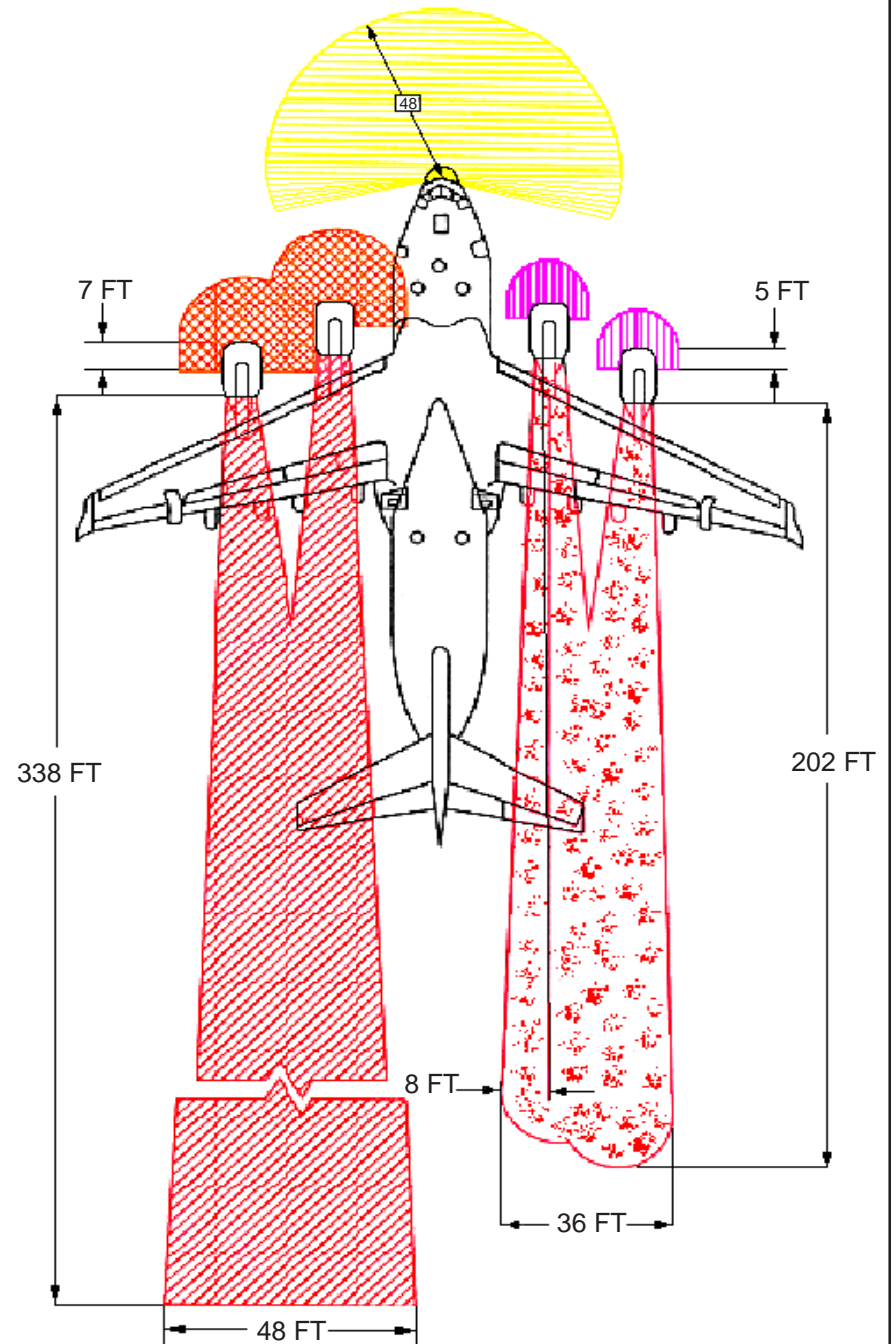

FIGURE 3. Example of external hazards.

# IMPACT DANGER AREAS

## 1. EJECTION SEAT AND HATCH TRAJECTORIES

### WARNING

Keep personnel and vehicles clear of impact areas during emergency entry.

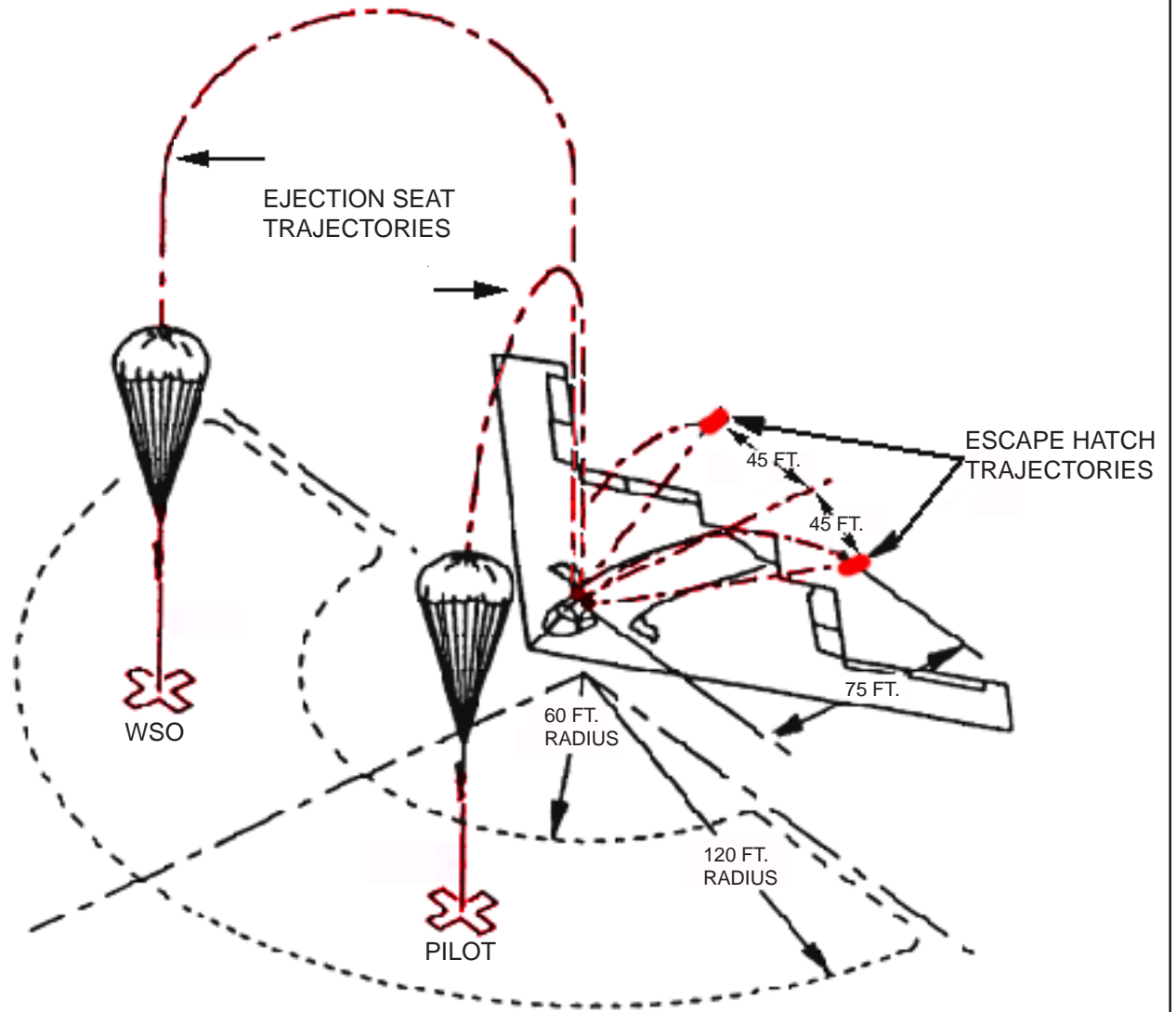







FIGURE 4. Example of external hazards.

F-117A.7

# AIRFRAME MATERIALS

## LEGEND

-  a. ALUMINUM - MAIN BODY
-  b. ALUMINUM - TITANIUM - AFT OF WING ROOTS
-  c. EPOXY FIBERGLASS - EDGES
-  d. GRAPHITE POLYETHERETHERKETONE (PEEK)  
- RUDDER, A PLASTIC THAT BURNS @ 600 DEGREES WITH TOXIC SMOKE
-  e. GRAPHITE EXPOXY - WEAPONS BAY DOOR
-  f. POLYIMID - AFT TRAILING EDGE - BURNS AT A HIGHER TEMPERATURE. > 600 DEGREES

### NOTE:

Composites comprise 5% or less of total structure and polyurethane plastic is paint coating.

10

# F-117A

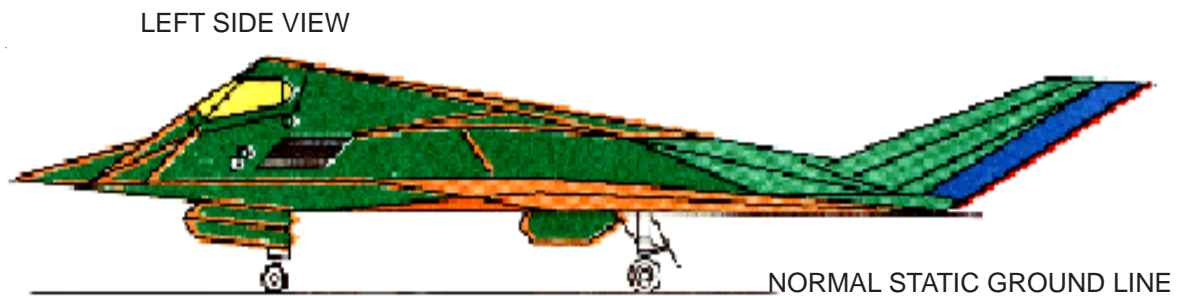
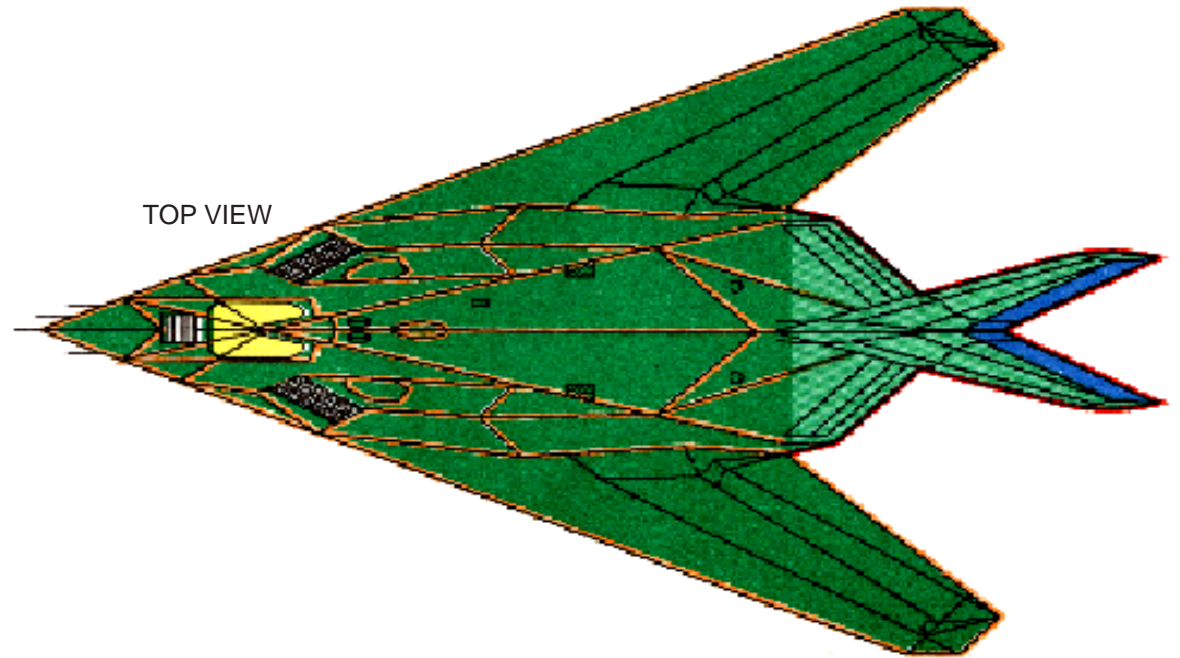

Item 10, PREPARATION INSTRUCTIONS  
T.O. 00-105E-9

DI-TMSS-81532

FIGURE 5. Example of airframe materials.

# AIRCRAFT SKIN PENETRATION POINTS

## NOTE:

Penetration points for all weapons bay doors are identical. Penetrate each door approximately 25 inches to the right or left of the aircraft centerline. The doors are 7 inches thick at the penetration point.

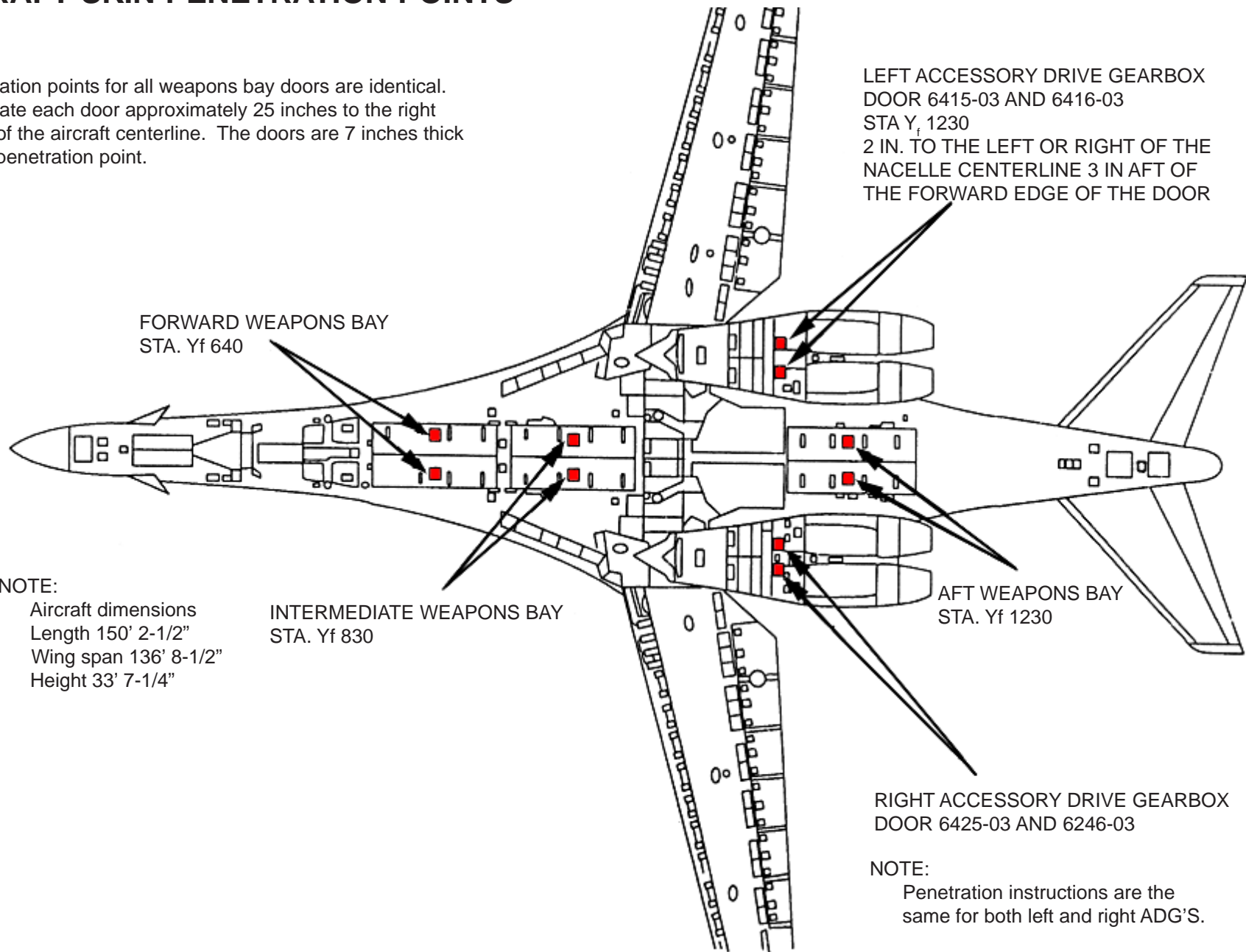

## NOTE:

Aircraft dimensions  
Length 150' 2-1/2"  
Wing span 136' 8-1/2"  
Height 33' 7-1/4"

## NOTE:

Penetration instructions are the same for both left and right ADG'S.

FIGURE 6. Example of skin penetration points.

**SPECIAL TOOLS/EQUIPMENT**  
 35 Ft Extension Ladder, "A" Frame Ladder,  
 Flathead Screwdriver for Oxygen Access,  
 Power Rescue Saw, Portable Lights, Fire Drill II

**AIRCRAFT ENTRY**

**WARNING**

Opening any aircraft door  
under pressurized conditions  
will injure or cause death to  
rescue personnel. Do not  
open any door until this  
condition does not exist!

**CAUTION**

During training or practice  
 scenarios, exerting too much  
 pressure when raising the  
troop doors will damage the  
door up-stops. These doors  
require little force to open.

**NOTE:**  
 Seat capacity depends  
 on cargo bay configuration  
 for passengers or litters.  
 Maximum Crew Seats (7)  
 Maximum Passengers (102)  
 Maximum Litters (48)

**NOTE:**  
 Fuel Information in US GALS  
 Total Fuel : 29,984  
 Fuel Type: JP-8

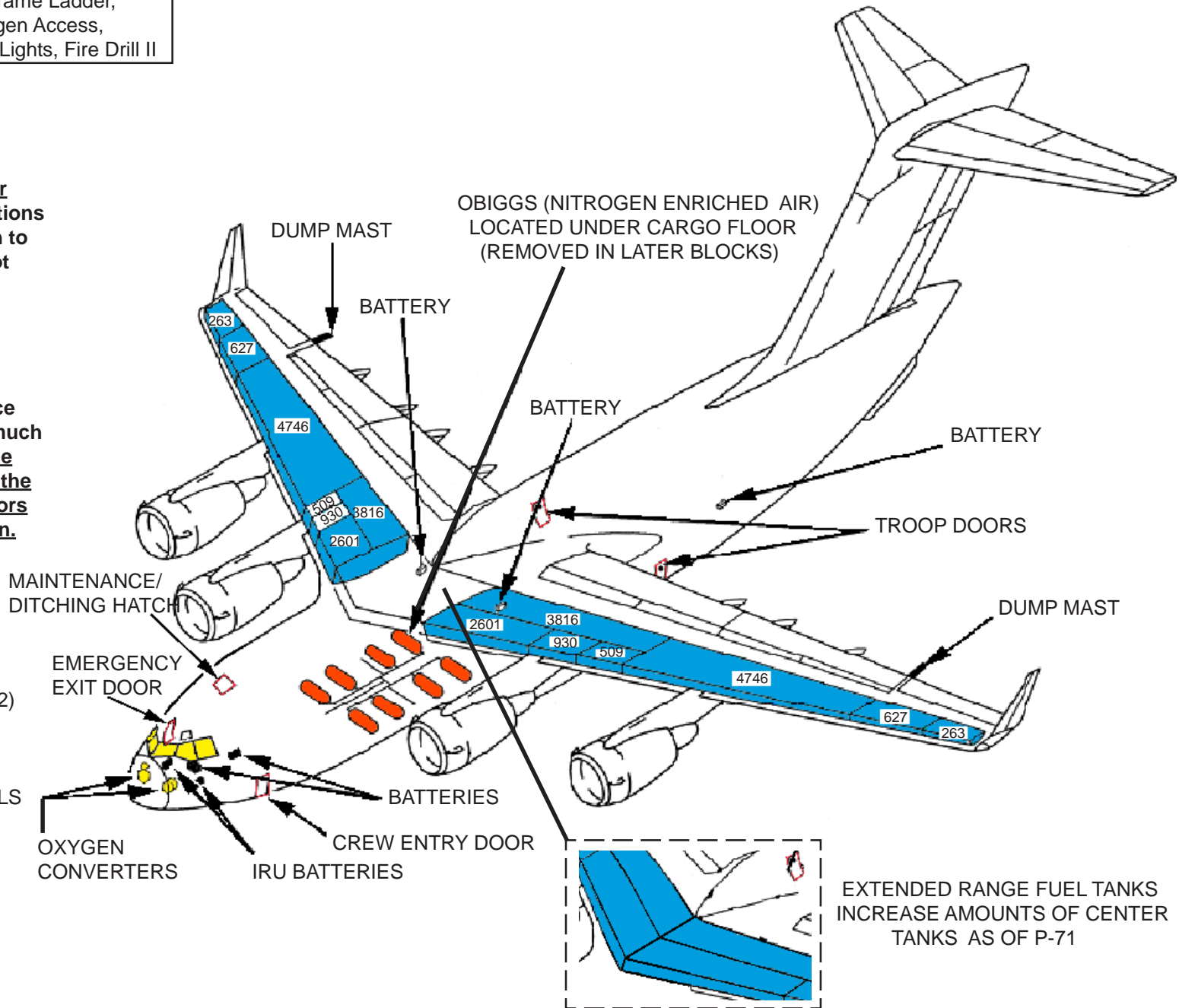

FIGURE 7. Example of list of special tools, number of personnel, entries, hatches, OBIGGS, and aircraft dimensions.

B-52.7

**SPECIAL TOOLS/EQUIPMENT**

- Cowling Key
- Disarming Tool
- Rescue Harness (Local Mfg)
- 25 Foot Ladder
- Fire Drill II

**B-52**

Item 10, PREPARATION INSTRUCTIONS  
T.O. 00-105E-9

**AIRCRAFT ENTRY B-52G/H MODELS**

**1. NORMAL ENTRY FORWARD COMPARTMENT**  
(Hatch located forward of landing gear.)

- a. Push release button in and pull handle down and open hatch.

**2. EMERGENCY ENTRY FORWARD COMPARTMENT**

**NOTE:**

Communicate with crew in order for the rescue crew to avoid being in the vicinity of a jettisoning or impacting hatch. Look through side windows to determine situation and condition of crew if communication can not be made.

**WARNING**

When a hatch is removed, the seat at that station will be armed and can be fired. Making entry through hatch should only be made as a last resort.

- a. If possible, make entry through side window and cut canopy jettison hatch hose and catapult hose.

**NOTE:**

Cut catapult hose on seat below top hatch(es) that entry was made through. Safety remaining ejection seats after engine shutdown.

- b. PILOT'S, CO-PILOT'S, EW OFFICER'S, and GUNNER'S ESCAPE HATCHES. Push release button in and pull handle up and open hatch.

- c. Lift and rotate aft until hatch disengages and separates from hinge points.

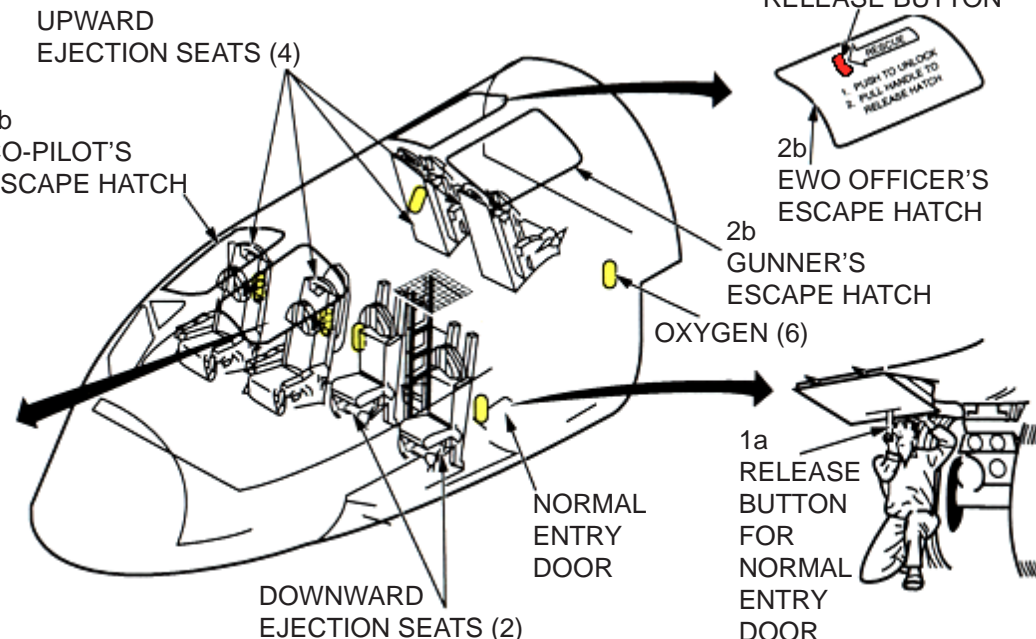
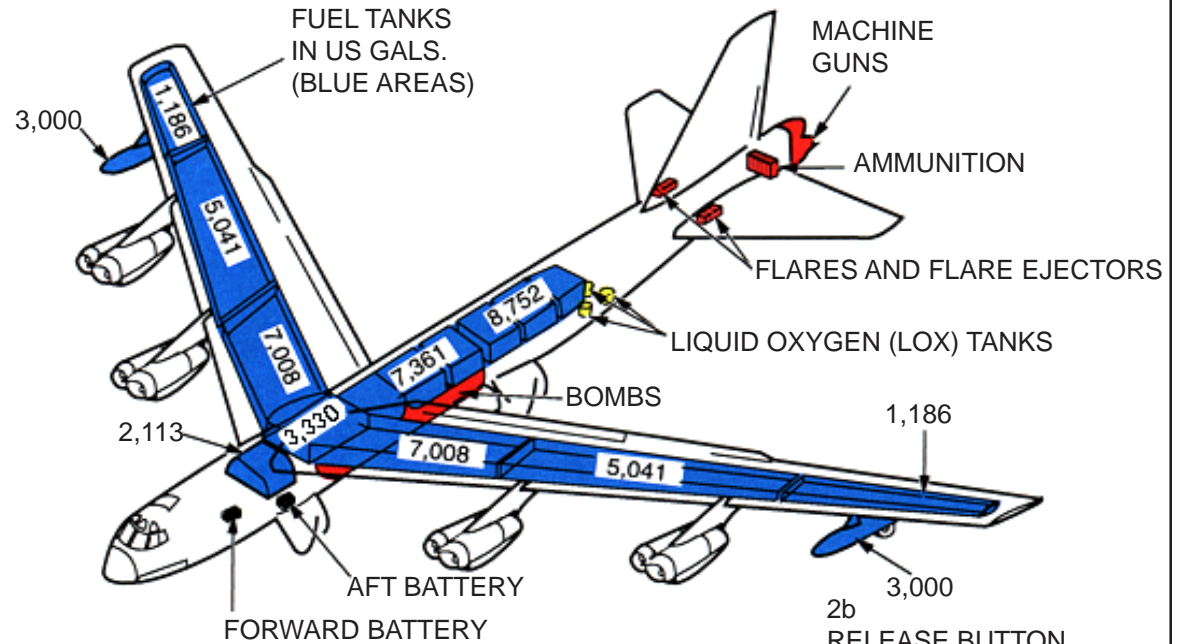

13

DI-TMSS-81532

FIGURE 8. Example of general view depicting fuel, oxygen, armament, batteries, list of special tools, normal and emergency entry, cut-in procedures and miscellaneous information.

## EMERGENCY ENTRY - Continued

## 2. CUT-IN AREAS

- a. Primary cut-in areas are on each of the two forward escape hatches. Use 5-inch cutting depth and remain within the cutting border.
- b. Secondary cut-in area approximately 3-1/2 feet aft of the right escape hatch. Use 5-inch cutting depth and remain within the cutting border.

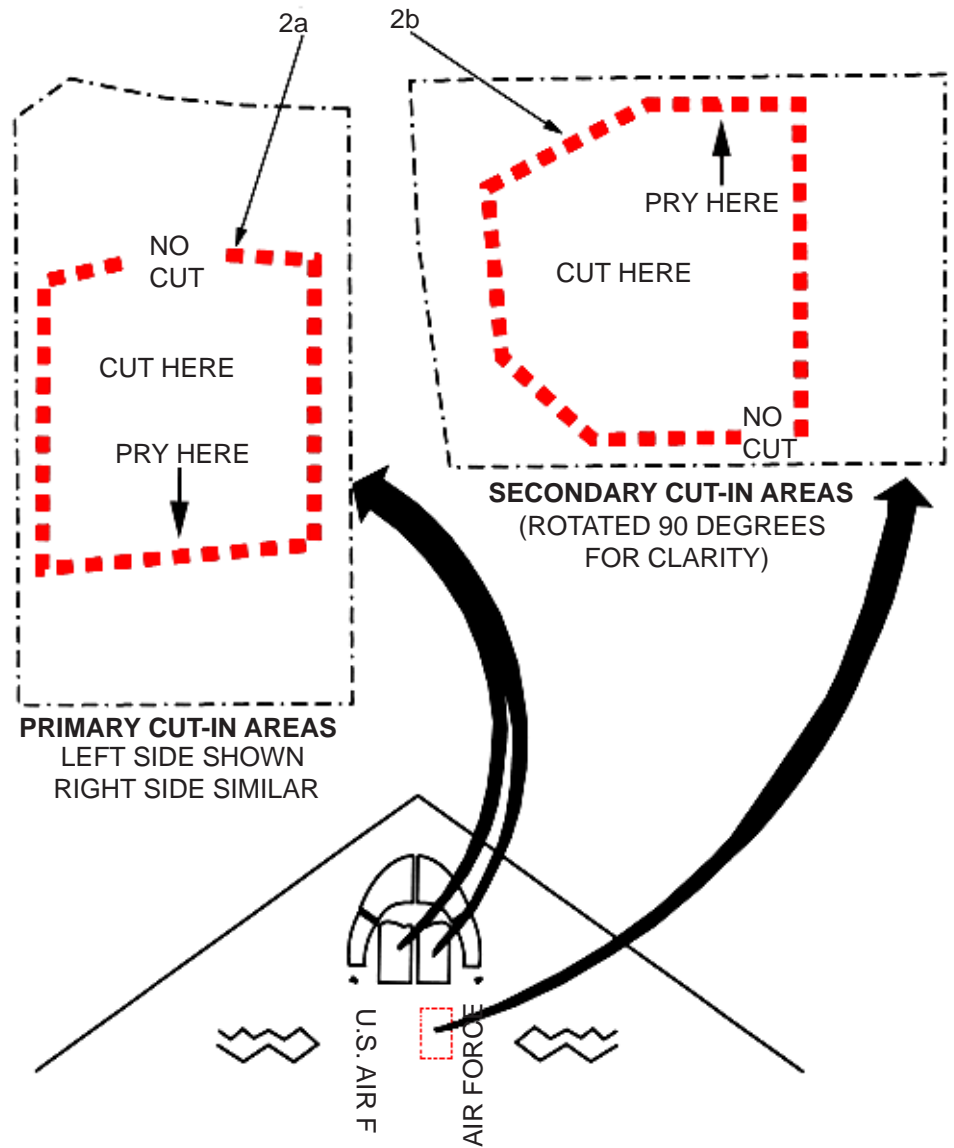

FIGURE 9. Example of cut-in areas.

**ENGINE SHUTDOWN****1. APU SHUTDOWN****NOTE:**

There are five (5) ways to shutdown the APU.

- (1) Position the APU switch to OFF.
- (2) Position the APU Emergency Shutdown switch in the left wheel well to EMER OFF.
- (3) Flood the APU inlet with extinguishing agent.
- (4) Command the APU to shutdown using the PMA.
- (5) Depress the APU FIRE Switchlight.

- a. Place the APU switch, located on the Electric Panel left console forward of throttles, to OFF.
- b. The APU FIRE Switchlight, located on the right glare-shield eyebrow, illuminates when a fire in the APU Compartment has been detected. Depressing the switchlight, on the ground, will shutdown the APU.
- c. The Emergency Shutdown Switch, located on the forward inboard side of the left main landing gear wheel well allows ground personnel to shutdown the APU during an emergency situation.

**2. ENGINE SHUTDOWN**

- a. Pull the friction lever, located left of left engine throttle, aft, to release throttle friction.
- b. Place the engine throttles, located on the left console, aft to lift over gate and continue aft to OFF.
- c. Depress the ENG FIRE warning switchlight, located on forward instrument panel, if illuminated. This action shuts off fuel, electrical power, ventilation, and air to the affected engine and arms the fire suppression system.
- d. If fire light remains illuminated: When the fire extinguisher is ready to discharge the extinguishing agent, the READY/DISCH switchlight, located on the forward instrument panel illuminates. When the switchlight is depressed, the READY light goes off and the DISCH switchlight illuminates indicating that the halon has been discharged to the selected compartment.
- e. Position battery switch, located on right corner panel, down to OFF. Another battery switch is located on the left main landing gear door frame above the PMA ports for external battery shutoff.

**F-22A**

APU/ENGINE FIRE SWITCHLIGHTS

2c  
LT ENGINE FIRE  
SWITCHLIGHT  
2d  
READY  
DIS-  
CHARGE

2c  
RT ENGINE FIRE  
SWITCHLIGHT  
1b  
APU FIRE  
SWITCHLIGHT

SWITCHLIGHT  
(with Guard Up)

2e  
INTERNAL  
BATTERY  
SWITCH

2a,b  
FRICTION LEVER  
AND THROTTLES

ELECTRIC PANEL

1a  
APU  
SWITCH



LEFT MAIN  
LANDING  
GEAR  
DOOR  
FRAME

2e  
EXTERNAL  
BATTERY  
SWITCH

PMA PORTS

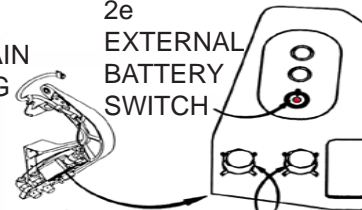

1c  
LEFT MAIN  
LANDING GEAR  
WHEEL WELL

APU  
NORM  
EMERG  
1a  
APU WHEEL  
WELL SWITCH

APU SHUTDOWN CONTROLS

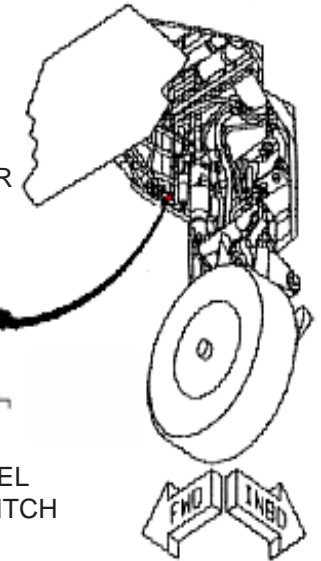

FIGURE 10. Example of engine shutdown procedures.

# SAFETYING EJECTION SYSTEM AND AIRCREW EXTRACTION

## 1. NORMAL SAFETYING FOR MARTIN-BAKER SEAT

**NOTE:**

Flight status safety pins are normally stored in the right forward console.

- Rotate ejection seat SAFE/ARMED handle forward, located on left side of seat, to the SAFE position.
- Insert seat safety pin in firing handle and housing, located forward center of seat.
- Insert internal canopy jettison safety pin over canopy jettison handle located on forward right console.
- Place the interseat sequencing handle, located at the left aft side console, in the SOLO mode. (See page T-38C.14.)

## 2. AIRCREW EXTRACTION

**NOTE:**

Refer to page T-38C.15 for additional help.

- Release tab on helmet to release oxygen mask allowing crewmember to breathe.
- Push in both plungers of each quick-release connector of the upper and lower leg garters and remove the leg garters from the aircrew's legs. Set garters aside to prevent leg and garter entanglement during extraction process.
- Disconnect the quick release connectors of the LH/RH attachment straps of the Seat Survival Kit (SSK) from the torso harness.
- Unlatch the lap belt at the center release mechanism.
- Unlatch each shoulder harness strap using release buckle.
- Lift feet from rudder pedals, lift knees and place feet on floor, then lift the aircrew from the cockpit.
- The oxygen hose and communication lead will automatically disconnect and fall away as the crewmember is extracted.

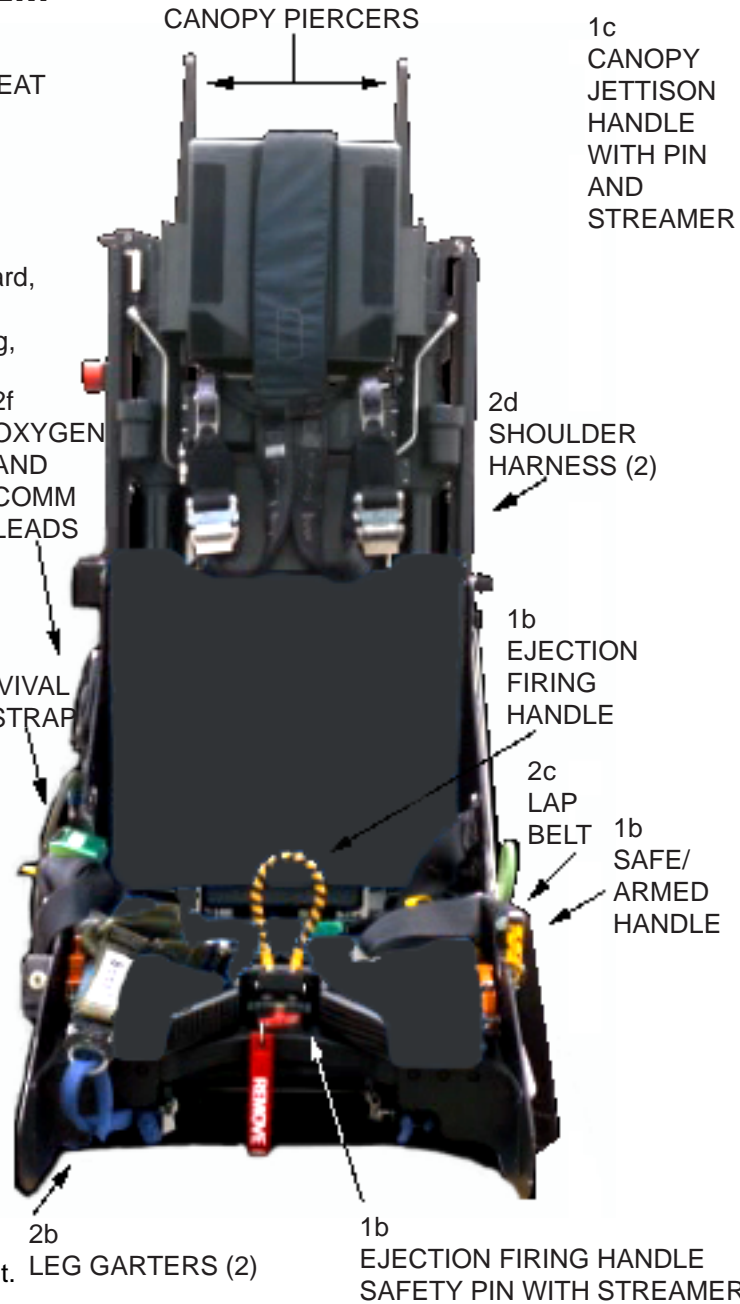

CANOPY JETTISON HANDLE (SAFED)

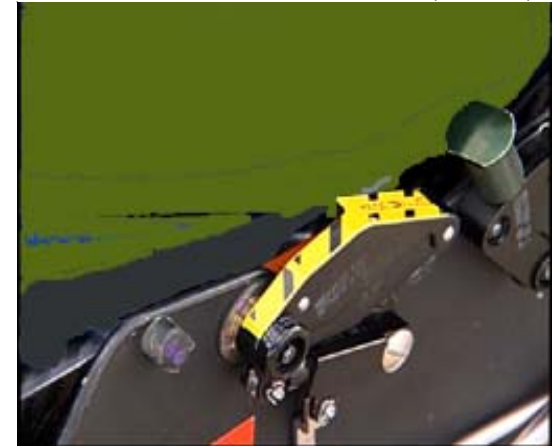

SAFE/ARMED HANDLE (ARMED)



SAFE/ARMED HANDLE (SAFED)

FIGURE 11. Example of safeing ejection seat and restraint systems.

E-4.15

# CABIN ARRANGEMENT

E-4

NOTE:

Doors that have a keyless lock are equipped with an emergency kickout panel. These entrances are marked on the floor plan with an asterisk(\*).

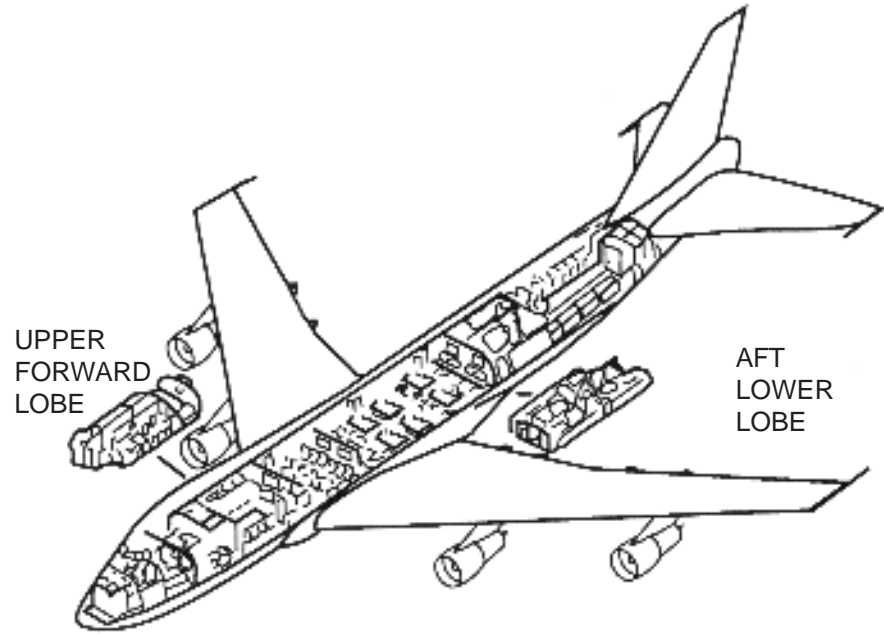
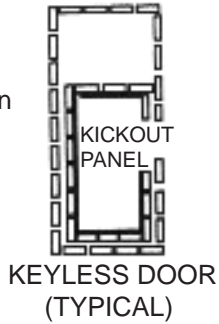

CREW SERVICE ENTRANCE DOOR UPPER FORWARD LOBE

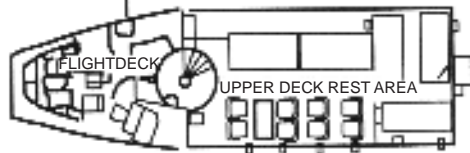

NO. 1 RIGHT MAIN DECK ENTRY DOOR

NO. 2 RIGHT MAIN DECK ENTRY DOOR

NO. 3 RIGHT MAIN DECK ENTRY DOOR

NO. 4 RIGHT MAIN DECK ENTRY DOOR

NO. 5 LEFT MAIN DECK ENTRY DOOR

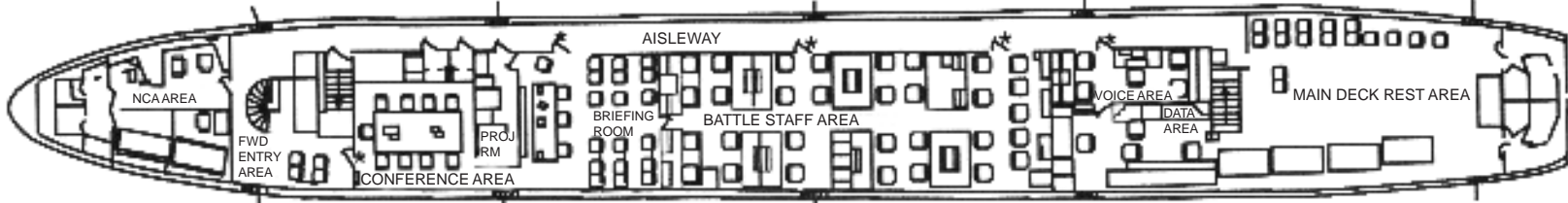

NO. 1 LEFT MAIN DECK ENTRY DOOR

NO. 2 LEFT MAIN DECK ENTRY DOOR

NO. 3 LEFT MAIN DECK ENTRY DOOR

NO. 5 LEFT MAIN DECK ENTRY DOOR

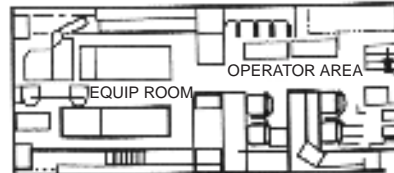

AFT LOWER LOBE

17

FIGURE 12. Example of cabin arrangement or configuration.

**SPECIAL TOOL**

## LOCAL MANUFACTURED TOOL

## NOTE:

This tool can be locally manufactured with 1/4" keyway stock for the 1/4" plug removal on the left side fuselage. The 1/4" keystack will prevent wearing out the plug head and accelerate the rescue process. See page F-16.10 steps 2a and 3a for application. Attach this tool to a socket wrench or speed handle. A substitute tool for the socket wrench or speed handle can be a cordless drill.

**WARNING**

DO NOT USE A POWERED DRILL TO OPEN THE CANOPY! The canopy mechanisms are not engineered for rapid opening and a malfunction can occur resulting in a possible falling canopy and failed rescue!

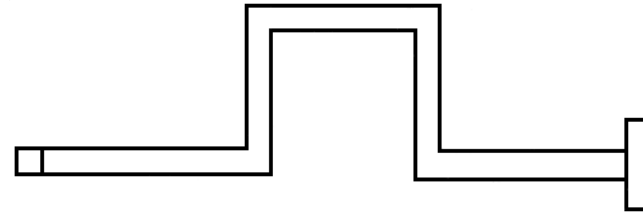

TYPICAL 1/4" DRIVE SPEED HANDLE FOR SPECIAL TOOL

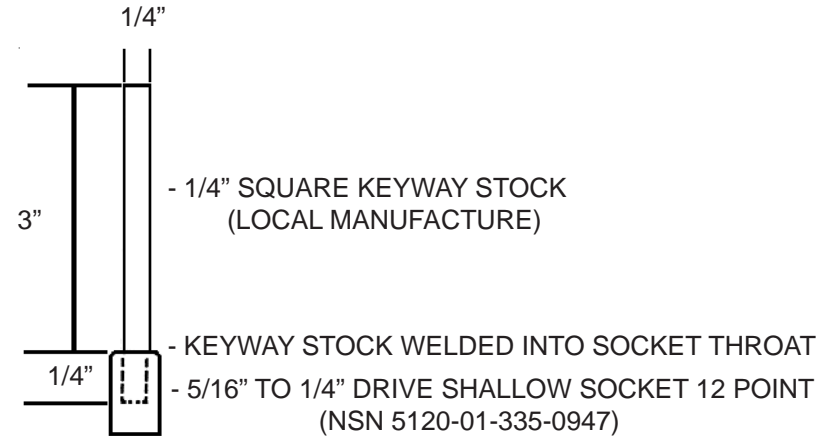

FIGURE 13. Example of special tools.