

INCH-POUND

A-A-55634

20 MARCH 1998

SUPERSEDES

V-F-106

20 April 1990

COMMERCIAL ITEM DESCRIPTION

ZIPPERS (FASTENERS, SLIDE INTERLOCKING)

The General Services Administration has authorized the use of this commercial item description by all Federal Agencies.

1. Scope: This document covers slide fasteners used for dress, coverall, aviation, rainwear, sleeping bag, equipage, body bag, chemical protective, anti-gravity (anti-g), diving suit, tentage and other miscellaneous and specialty end item applications.

2. Classification: This section contains zipper configuration types/styles, descriptions and definitions.

2.1. Types/Styles: Following tables references availability of all potential zipper configurations relative to types and styles.

TABLE I. Type I Fastener, Nonseparating, Nonreversible

Style	Lock 1/	Top Stop	Bottom Stop	Slider Arrangement 2/
1	Pin or cam			Single
2	Automatic	Without	Without	
3	Without			
4	Automatic			
5	Pin or cam	Open	Closed	
6	Without			
7	Automatic			
8	Pin or Cam	Bridge	Closed	
9	Without			Multiple (mouth to mouth)
10	Automatic			
11	Pin or cam	Open	Open	
12	Without			
13	Automatic			
14	Pin or cam	Open	Bridge	
15	Without			
16	Automatic			
17	Pin or cam	Bridge	Bridge	
18	Without			Multiple (throat to throat)
19	Automatic			
20	Pin or cam	Closed	Closed	

Beneficial comments, recommendations, additions, deletions, clarifications, etc. and any data which may improve this document should be sent to Defense Industrial Supply Center, ATTN: DISC-AEEB, 700 Robbins Avenue, Philadelphia PA 19111-5096.

A-A-55634

TABLE II. Type II Fastener, Nonseparating, Reversible 3/

Style	Lock 1/	Top Stop	Bottom Stop	Slider Arrangement 2/
1	Without			Single
2	Automatic	Open	Closed	
3	Without	Bridge	Closed	
4	Automatic			
5	Without	Open	Open	Multiple (mouth to mouth)
6	Without	Bridge	Bridge	
7	Without	Closed	Closed	Multiple (throat to throat)

TABLE III. Type III Fastener, Separating, Nonreversible

Style	Lock 1/	Top Stop	Bottom Stop	Slider Arrangement 2/
1	Without		Right-hand separating unit	Single
2			Left-hand separating unit	
3	Without	Open	Right-hand separating unit	
4			Left-hand separating unit	
5	Automatic	Right-hand quick release	Right-hand separating unit	
6	Automatic	Left-hand quick release	Left-hand separating unit	
7	Automatic		Right-hand separating unit	
7A	For Anti-Gravity	Clothing use	Left-hand separating unit	
8	Automatic		Right-hand separating unit	
8A	For Anti-Gravity	Clothing use	Left-hand separating unit	
9	Without	Right-hand quick release	Right-hand separating unit	Multiple (mouth to mouth)
10	Without	Left-hand quick release	Left-hand separating unit	
11	Automatic	Right-hand quick release	Right-hand separating unit	
12	Automatic	Left-hand quick release	Left-hand separating unit	
13	Automatic	Open	Left-hand separating unit	Multiple (throat to throat)
14	Automatic	Open	Right-hand separating unit	
15	Automatic	Left-hand separating unit	Right-hand separating unit	
16	Without	Left-hand separating unit	Right-hand separating unit	

A-A-55634

TABLE IV. Type IV Fastener, Separating, Reversible 3/

Style	Lock 1/	Top Stop	Bottom Stop	Slider Arrangement 2/
1	Without	Open	Right-hand separating unit	Single
2	Without	Open	Left-hand separating unit	
3	Without	Right-hand quick release	Right-hand separating unit	
4	Without	Left-hand quick release	Left-hand separating unit	
5	Automatic	Open	Right-hand separating unit	Multiple (mouth to mouth)
6	Automatic	Open	Left-hand separating unit	

1/ Cam type locks are not applicable to continuous element fasteners. Automatic locks include ratchet type locks. Cam and pin lock include semi-automatic pin locks.

2/ All components shall be from the same manufacturer; otherwise zippers may be dysfunctional.

3/ Reversible sliders are those which have a pull on both the front and back of the slider.

2.2. Zipper Definitions:

2.2.1 Chain: Chain is a continuous closure, formed by interlocking the elements on one tape alternately with those on the other tape. Existing types of chain are continuous element, individual element zippers and self-sealing.

2.2.1.1 Individual Element Fasteners (IEF). (See Figures I & II)-Two rows of interlockable separately - formed teeth called scoops or elements, each attached to one of the opposing edges of two tapes, most commonly manufactured from, but not restricted to: brass, aluminum or Delrin® plastic polymer. The latter no. 9 plastic element has two classes of chain, class 1- normal duty and class 2-heavy duty.

2.2.1.2 Continuous Element Fasteners (CEF). (See Figures I & II)- The elements may be formed as a strand of configured monofilament or elements with integrally formed interconnecting webs or elements individually molded or fused to an interconnecting cord or cords. These rows of elements are attached either by sewing or by being integrally woven into the tape fabric. The woven model generally supplies a higher degree of abrasion resistance; however, it is best to discuss application with zipper manufacturer. CEF's are commonly manufactured from either polyester or nylon polymer.

A-A-55634

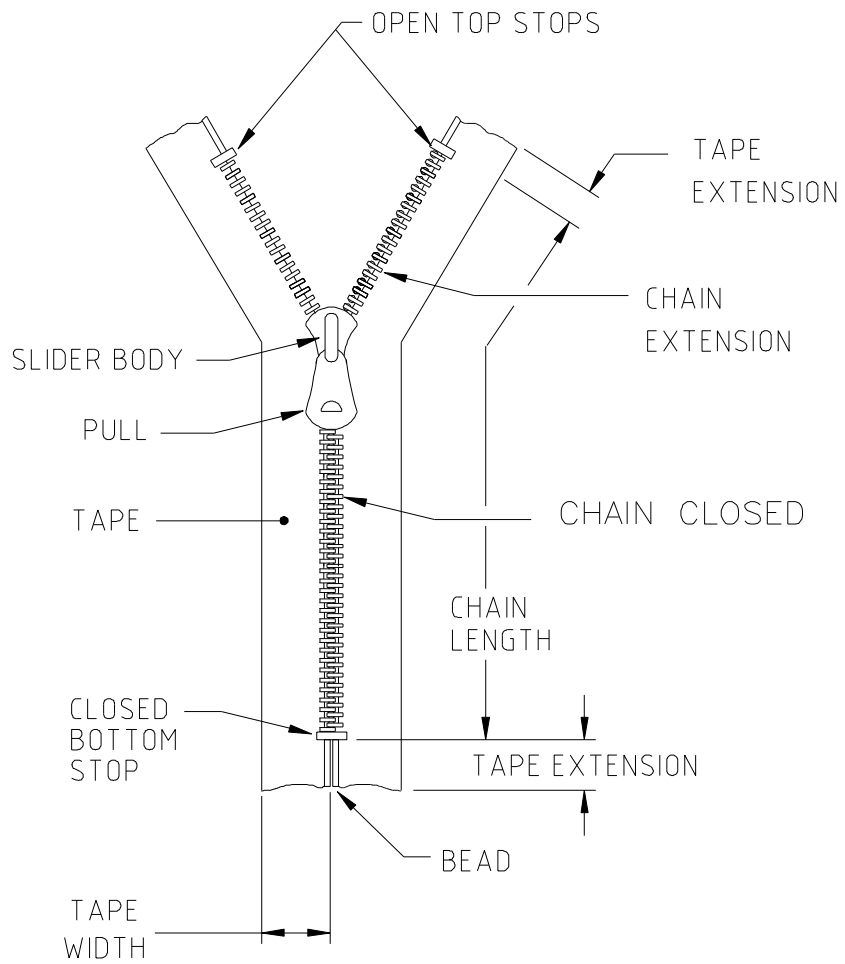

Fig. I - Zipper components common to IEF and CEF fasteners

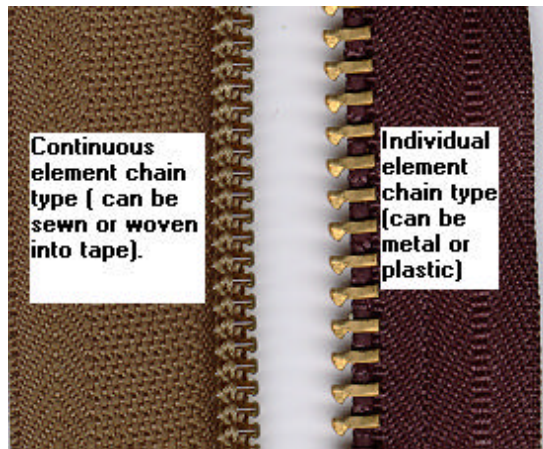

Fig. II - CEF & IEF chain elements

2.2.1.3. Self-Sealing Zippers. (See Figure III)-Two rows of interlockable rubberized CEF or metal IEF chain that prevents moisture penetration under hydrostatic pressure.

A-A-55634

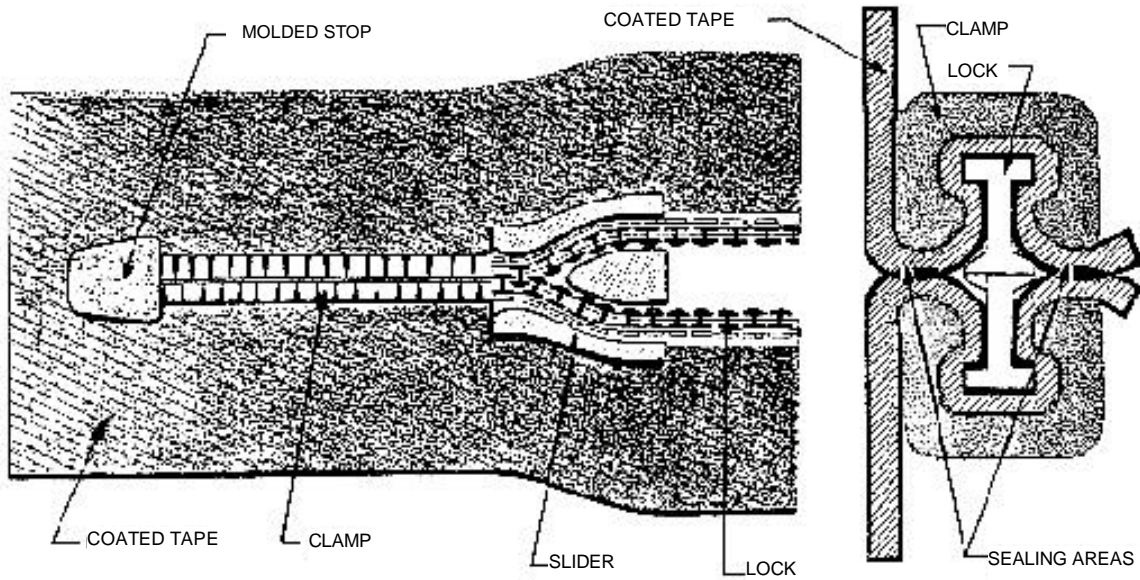

Fig. III- Self-Sealing Fastener

2.2.1.4 Anti-Gravity Zippers. (See Figure IV for typical pin and box interface)-Fastener generally described as size 9, black oxidized brass individual element fastener chain that provides a secure pressurized pin and box locking mechanism. Dimensions shown in Figure IV are nominal. Parts shall be fully functional for intended use.

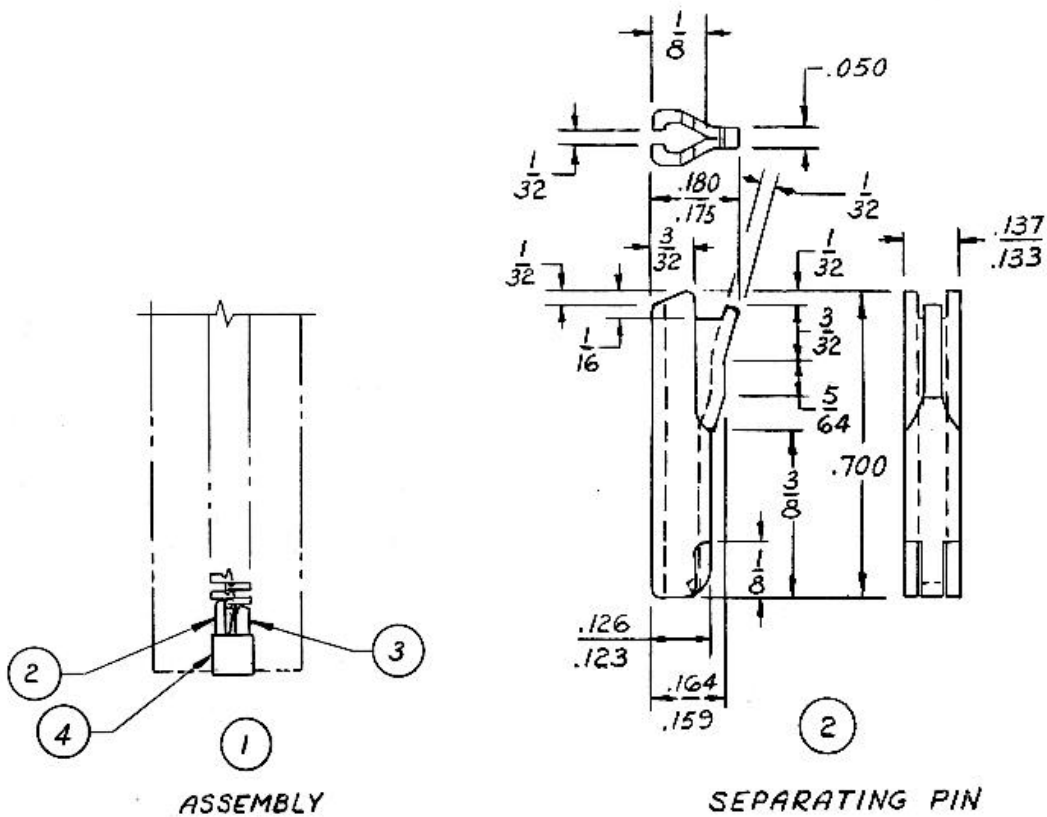

Fig. IV-Pin & Box Interface

A-A-55634

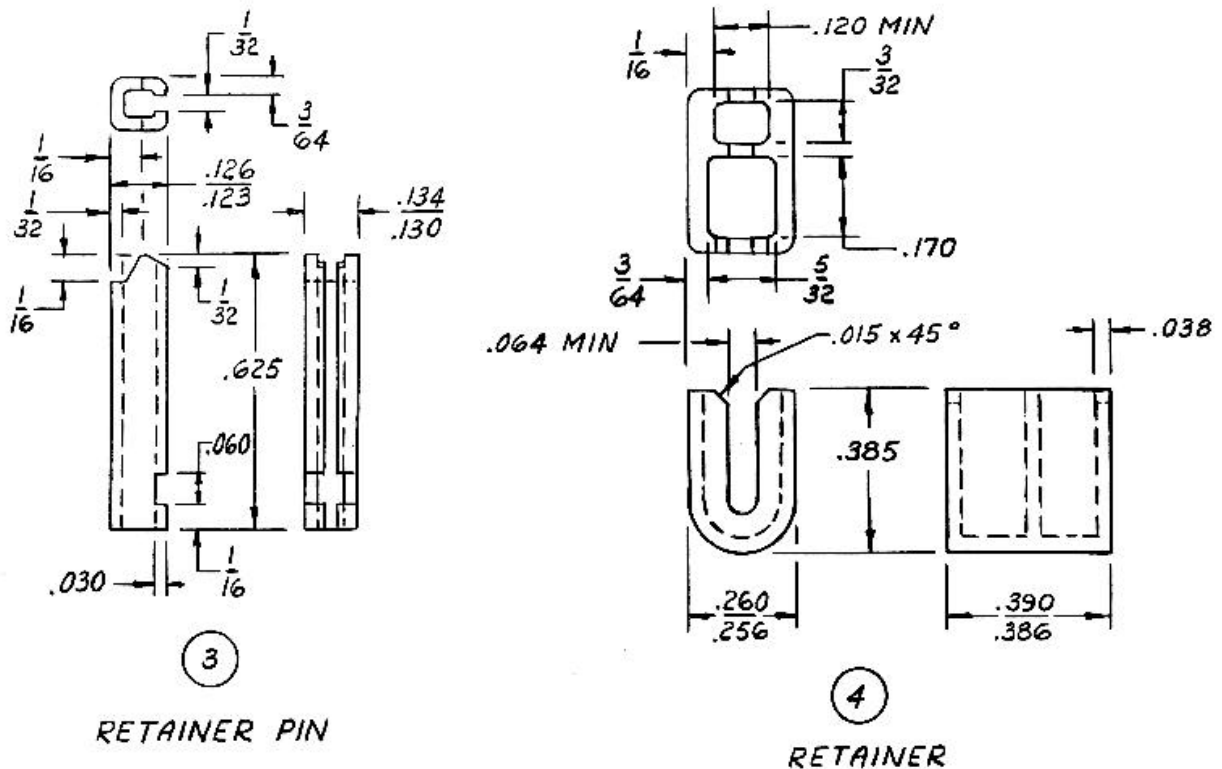

Fig. IV-Pin & Box Interface (Continued)

2.2.2 **Size:** Zipper size is determined by combination of closed chain width and physical characteristics per Table V. There are a total of 10 separate sizes within 6 size groups, ranging from 1 through 10. Maintaining all requirements of any intrarange size products shall be the responsibility of the manufacturer.

2.2.3 **Tape:** IEF zipper chains are connected/attached to tape fabrics having an overall width which yield a specific sewable area. CEF chains are connected/attached via sewn threads or woven into tape. These tapes are listed in Table V as typical tape widths (self-sealing types are as specified). See Section 4 for tape width tolerance. Specific tape widths shall be designated by the zipper manufacturer as required. Tape materials (except self-sealing) are generally polyester or Nomex® (defined either as aramid or high-temperature-resistant polyamide).

2.2.4 **Tape Ends/Extensions:** Shall be of a length that is practical for sewing, unless otherwise specified in the contract. All tape ends shall be treated to prevent fraying. Typical methods are: coated type, bonded reinforcement, tape impregnation, hot knife, ultrasonic sealing, or pinking.

2.2.5 **Sliders:** (See Figure V) Sliders are movable components which span the two rows of elements comprising the chain. The slider, when moved, will open and close the zipper chain. Sliders come in either single or multiple arrangement in order to open/close in a specific manner. Sliders may be equipped with locks, these being automatic, pin, semi-automatic pin locks and cam locks. The semi-automatic pin lock slider may be interchanged for cam locks. The manufacturers name or I.D. shall be imprinted either on the slider body or pull.

A-A-55634

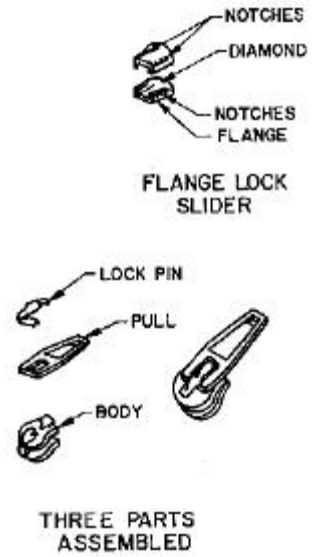
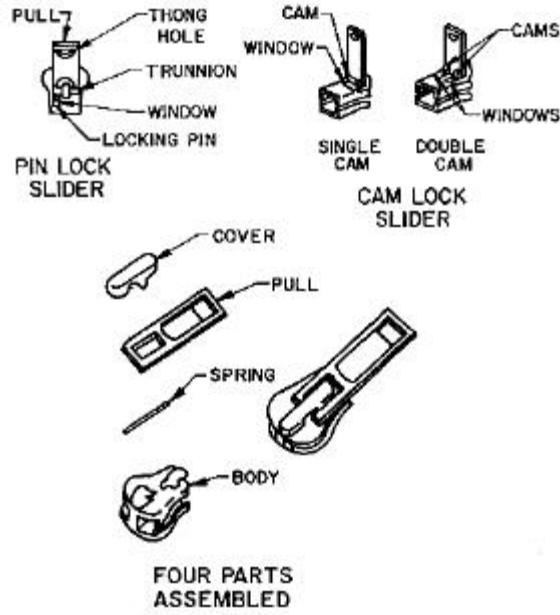
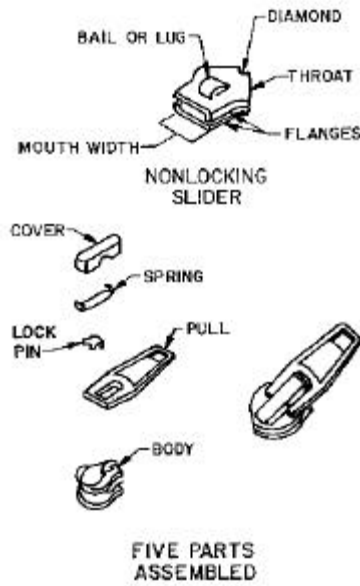

AUTOMATIC LOCK SLIDER

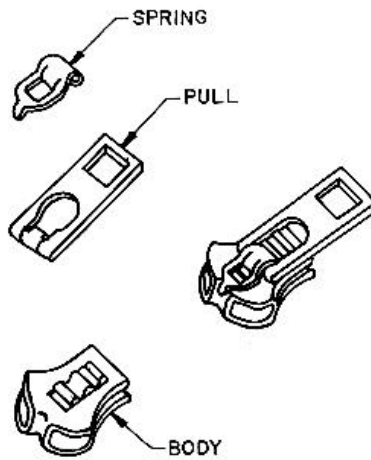

SEMI-AUTOMATIC PIN-LOCK SLIDER

Fig. V- Slider Types

A-A-55634

2.2.6 **Slider Pulls:** (See Figure VI) Slider pulls provide the movement of the sliders. Unless otherwise specified, they can be either short (below 7/8 inch long), long (7/8 inch or longer), padlock, chain or stirrup pull. Pull arrangements are of two main types:

Non-Reversible - Opens and closes from one side.

Reversible - Opens and closes from both sides, shall be single pulls on both sides.

A thong may be attached to a slider pull to facilitate opening of a zipper while wearing gloves. When specified, any pull that provides a hole large enough to accommodate a thong may be used.

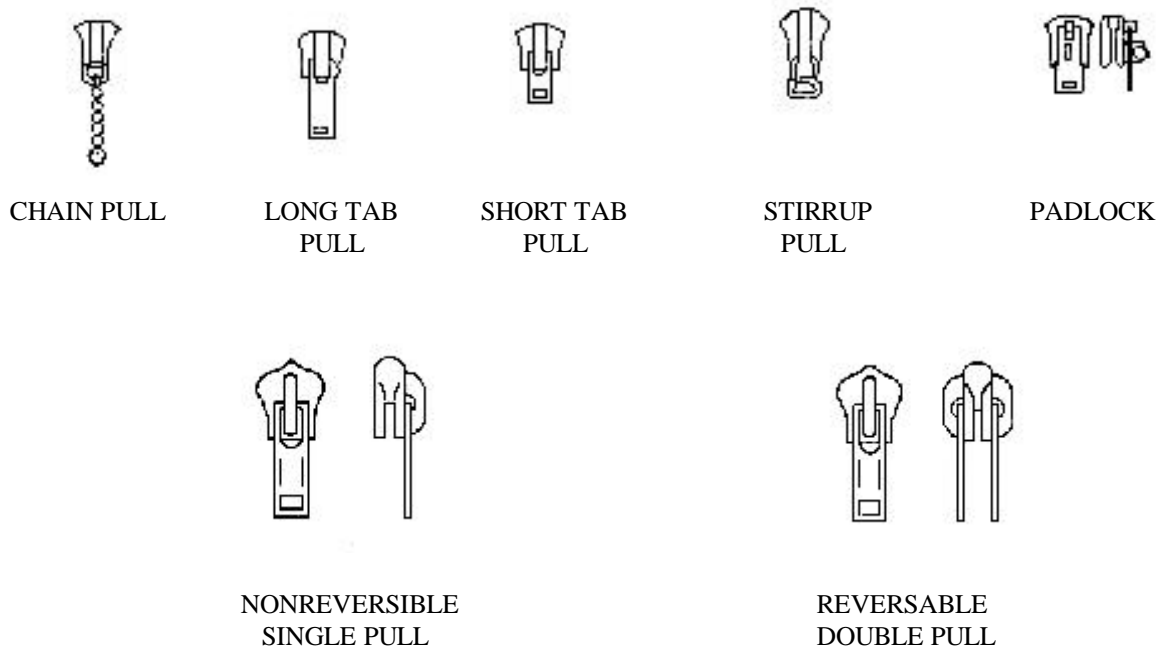

Fig. VI- Slider Pull Types

2.2.7 **Thongs:** Thongs are independent textile webbing/braid/outershell material extensions to the slider pulls. Finished length of the thong after assembly to the pull shall be $6 \pm 3/4$ inches, unless otherwise stated. The thong material shall be 3/8" wide and have a breaking strength of 100 lbs. minimum. Thongs shall be tied to the pull. Thong ends shall be bartacked or treated to prevent fraying.

2.2.8 **Top and Bottom Stops:** Element or elements used to restrict the movement of the slider. The use of a staple or folded type stop shall not be used in lieu of a bridge stop, except in the case of continuous element (CEF) fasteners.

2.2.9 **Zipper Length:** The length of the fastener shall be measured from the bottom of the bottom stop to the top of the top stop. For self-sealing fasteners, the length is measured from the top of the bottom stop to the top of the slider when against the top stop.

2.2.10 **Quick-Release Stops:** This device shall temporarily limit the travel of the slider at the open end of the chain under normal closing operation. It shall permit the slider to be forced beyond the stop when an additional force is exerted against the slider. The performance requirements for this device shall be established between the design activity and the manufacturer. However, quick release stops shall endure a minimum of 200 cycles when pulled (either manually or mechanically) beyond the quick release stop.

A-A-55634

2.2.11 Separating Unit (hand): (See Figure VII) Separating units are used in application where two chain sides must be released from each other. All separating zippers shall be capable of being engaged and disengaged in a smooth even manner with minimal force. Separators come in two "Hands", left and right. To determine the "Hand" of a separator: When a separating zipper having a single pull is viewed, as worn, with the chain in a vertical position and the separating unit at the bottom of the chain, the zipper will be considered "Left Hand" if the separating pin is on the observers left and "Right Hand" if the separating pin is on the observers right. Unless otherwise specified, all separating units are left hand.

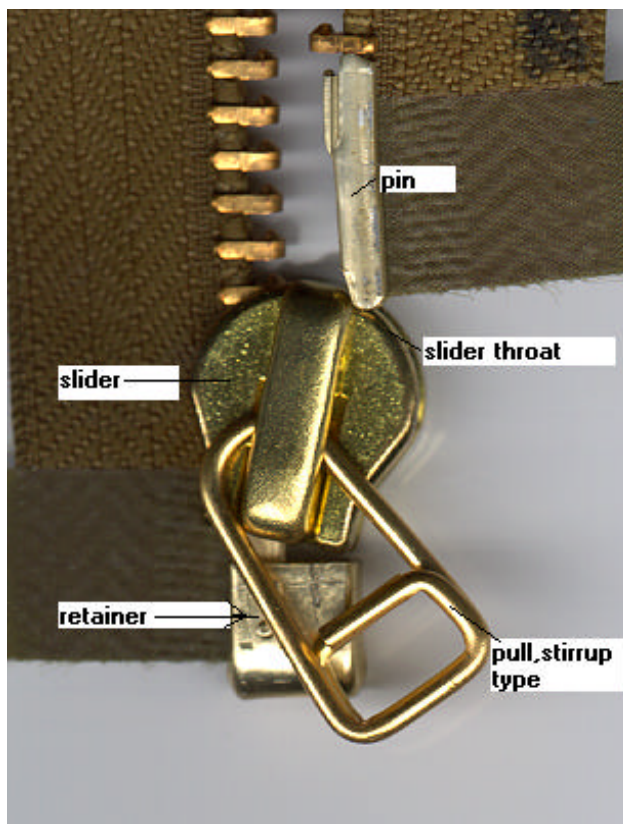

Separating unit as shown is 'Left Hand'. If the placement of the separating pin and retainer were on opposite sides, it would become 'Right Hand'. *NOTE. The stirrup type pull is for illustration purposes only.*

Fig. VII- Separator Hand

2.2.12 Interchangeability: An interchangeable slide fastener shall be a separating type which is so constructed that when the two stringers of the chain are separated, each stringer can be joined and operated using the slider provided by the manufacturer with the opposing stringer of other fasteners of the same size and design from a single manufacturer. Neither like size interchangeable fasteners nor sliders from different manufacturers are to be considered interchangeable with each other.

3. Salient Characteristics:

3.1 Physical Performance Requirements: Table V exhibits performance requirements relative to specific size category.

A-A-55634

TABLE V. Performance Requirements

<u>Physical Characteristic</u>	<u>Fastener Sizes</u>					
	<u>1-2</u>	<u>3-4</u>	<u>5-7</u>	<u>8</u>	<u>9</u>	<u>10</u>
Closed Chain Width, in.	.125 - .180		.180 - .310	.310 - .390		.320 - .500
Tape Width, in. ($\pm 1/16$ in.)	7/16 - 9/16		9/16 - 3/4	5/8 - 3/4		3/4 - 1.0
<u>Strength Tests:(lbs. min.)</u>						
<u>A. Crosswise Breaking Strength of Chain:</u>						
Individual Element Fasteners, (IEF)						
Brass, Nickel	60	70	130	190	200	225
Anti-G	-	-	-	-	250	-
Aluminum	65	65	90	100	110	125
Plastic, Class I, Normal Duty	60	65	100	130	145	160
Class II, Heavy Duty	-	-	-	-	250	-
Continuous Element Fasteners, (CEF)	80	80	175	200	225	250
<u>B. Crosswise of Separating Unit:</u>						
IEF						
Brass, Nickel, Anti-G	20	20	30	30	90	110
Aluminum	20	20	30	30	75	90
Plastic, Class I	20	20	30	30	50	65
CEF	20	20	30	30	40	50
<u>C. Single or Individual Element Pull-Off:</u>						
(Not applicable to continuous element fasteners)						
IEF						
Brass, Nickel, Anti-G	5	9	12	24	28	30
Aluminum	5	7	9	14	15	16
Plastic, Class I	5	6	12	20	20	20
Class II	-	-	-	-	26	-
<u>D. Single or Individual Element Slippage Lengthwise:</u>						
(Not applicable to continuous element fasteners)						
IEF						
Brass, Nickel, Anti-G	5	9	12	17	17	17
Aluminum	4	6	9	13	14	17
Plastic, Class I	5	6	10	17	17	17
Class II	-	-	-	-	22	-

A-A-55634

TABLE V. Performance Requirements (Continued)

Physical Characteristic	Fastener Sizes					
	<u>1-2</u>	<u>3-4</u>	<u>5-7</u>	<u>8</u>	<u>9</u>	<u>10</u>
<u>E. Holding Strengths of Stops, Retainers, and Separating Units</u> (Quick Release shall be 1/2 of value shown)						
IEF						
Brass, Nickel, Anti-G	15	15	25	35	50	50
Aluminum	15	15	25	35	35	40
Plastic, Class I	10	10	20	35	35	35
CEF	15	15	25	35	35	35
<u>F. Operating Force Tests:</u> (Maximum in Pounds) Slider on Chain						
IEF						
Metal	1.5	1.5	2.5	3.5	3.5	4.5
Plastic, Class I	2.0	2.0	2.0	2.5	2.5	3.5
Class II	-	-	-	-	3.0	-
CEF	2.0	2.0	2.0	2.5	2.5	3.5
<u>G. Slider on Chain After Salt Spray:</u>						
IEF						
Metal	3.0	3.0	5.0	7.0	7.0	9.0
Plastic, Class I	4.0	4.0	4.0	5.0	5.0	7.0
Class II	-	-	-	-	5.0	-
CEF	4.0	4.0	4.0	5.0	5.0	7.0
<u>H. Slider Resistance to Cushioned Compression:</u> (Pounds to be applied) all fasteners						
	100	100	200	500	500	500
<u>I. After Cushioned Compression:</u> (Maximum Operating Force)						
IEF						
Metal Fasteners	1.5	1.5	2.5	2.5	3.5	4.5
Plastic, Class I	3.0	3.0	3.0	3.0	3.5	4.0
Class II	-	-	-	-	3.5	-
CEF	3.0	3.0	3.0	3.0	3.5	4.0
<u>J. Slider Lock Strength:</u> (lbs.min.)						
	3.0	3.0	7.0	7.0	7.0	10.0

A-A-55634

3.2 Water Repellency: When designated, zipper tape shall be water repellent treated so as not to absorb more than 9.5% moisture after one laundering. Any treatment shall use only EPA approved chemicals with no toxicity. See Section 4 for test method.

3.3 Color Matching: Specific color standards (i.e. CG 483, Tan 380, etc.) shall be supplied to the manufacturer by the procuring activity when requested. The color of the finished tape shall match the standard sample when viewed under filtered tungsten lamps that approximate artificial daylight and that have a correlated color temperature of 7500 ± 200 K with illumination of 100 ± 20 foot candles, and shall be a good match to the standard sample under incandescent lamplight at 2300 ± 200 K. Color of zipper components (tape, chain, sliders, thongs, stops, pin and box) shall all approximately match except CEF, where the pin/box shall be in accordance with manufacturers standard practice.

3.4 Black oxidized finish: Any non-glossy (dull) black oxidized finish shall be durable with no chipping or delamination up to 3 home laundings. See Section 4 for test method.

3.4.1 Enameled Finish: When required, metallic components shall be enameled to match the shade of the tape, unless otherwise specified in the procurement document. Anodizing or chromate finish are not allowed.

3.5 Colorfastness Requirements: Specific colorfastness requirements including chlorine bleaching, weathering, wet dry-cleaning, light, laundering and dry heat sublimation shall be designated in the procurement document. Nomex® fastener tape shall only be subjected to 6 standard fading hours. All ratings (as applicable) shall be "good". See Section 4 for test methods.

3.6 Salt Spray Resistance: When applicable, a 5% salt spray solution shall be exposed to the zipper for 24 hours (unless otherwise specified). See Section 4 for test method.

3.7 Tape Uniformity (straightness) of chain: Overall fastener chain shall be uniform to 1/16 of an inch and 5 inch length. See Section 4 for test method.

3.8 Continuous Chain Application: Continuous chain application may be utilized as an alternate to preassembled Type I and II slide fasteners as part of the manufacturing method. This method requires that the entire chain, tape and tape extensions be securely stitched with the required seam without any puckering or waviness. The slider shall be indexed into position to provide for a smooth running chain disengagement with its mouth squarely against the bottom stop and smooth running chain engagement with its throat evenly against the top stops with no excess chain elements showing. If continuous element monofilament chain is used, sewn stops, without gapping, are allowed.

3.9 Flatness: Fastener chain shall be flat without waviness. See Section 4 for test method.

3.10 Length Tolerances: Unless otherwise specified, the tolerances shall be as specified in Table VI. All interchangeable slide fasteners for each length of a single manufacturer's design must be made according to a uniform element account (see interchangeability) and length tolerance shall be twice those indicated in Table VI, except that the total tolerance shall be equally divided on the plus or minus side. On removable lining applications the slide fasteners may be center marked in accordance with user requirements.

A-A-55634

TABLE VI - Length Tolerance

Fastener Length, in.	Size 1-4		5-7		8-9		10	
	plus	minus	plus	minus	plus	minus	plus	minus
to 12	1/8	1/8	3/16	3/16	1/4	1/4	5/16	5/16
12-1/4 to 18	1/8	3/16	3/16	1/4	1/4	5/16	5/16	3/8
18-1/4 to 24	1/8	1/4	3/16	5/16	1/4	3/8	5/16	7/16
24-1/4 to 30	1/8	5/16	3/16	3/8	1/4	7/16	5/16	1/2
30-1/4 to 36	1/8	3/8	3/16	7/16	1/4	1/2	5/16	9/16
36-1/4 to 42	1/8	7/16	3/16	1/2	1/4	9/16	5/16	5/8
42-1/4 to 48	1/8	1/2	3/16	9/16	1/4	5/8	5/16	11/16
48-1/4 to 54	1/8	9/16	3/16	5/8	1/4	11/16	5/16	3/4
54-1/4 to 60	1/8	5/8	3/16	11/16	1/4	3/4	5/16	13/16
60-1/4 to 66	1/8	11/16	3/16	3/4	1/4	13/16	5/16	7/8
66-1/4 to 72	1/8	3/4	3/16	13/16	1/4	7/8	5/16	15/16
72-1/4 to 78	1/8	13/16	3/16	7/8	1/4	15/16	5/16	1
78-1/4 to 84	1/8	7/8	3/16	15/16	1/4	1	5/16	1-1/16
84-1/4 to 90	1/8	1-5/16	3/16	1	1/4	1-1/16	5/16	1-1/8
90-1/4 to 96	1/8	1	3/16	1-1/16	1/4	1-1/8	5/16	1-3/16
96-1/4 to 102	1/8	1-1/16	3/16	1-1/8	1/4	1-3/16	5/16	1-1/4
102-1/4 to 108	1/8	1-1/8	3/16	1-3/16	1/4	1-1/4	5/16	1-5/16
108-1/4 to 114	1/8	1-3/16	3/16	1-1/4	1/4	1-5/16	5/16	1-3/8
114-1/4 to 120	1/8	1-1/4	3/16	1-5/16	1/4	1-3/8	5/16	1-7/16
120-1/4 to 126	1/8	1-5/16	3/16	1-3/8	1/4	1-7/16	5/16	1-1/2
126-1/4 to 132	1/8	1-3/8	3/16	1-7/16	1/4	1-1/2	5/16	1-9/16
132-1/4 to 138	1/8	1-7/16	3/16	1-1/2	1/4	1-9/16	5/16	1-5/8
138-1/4 to 144	1/8	1-1/2	3/16	1-9/16	1/4	1-5/8	5/16	1-11/16
144-1/4 to 150	1/8	1-9/16	3/16	1-5/8	1/4	1-11/16	5/16	1-3/4
150-1/4 and over	1/8		3/16		1/4		5/16	

For fasteners over 150-1/4 inches long, the minus shall be 1-13/16 inches plus 1/16 inch for each additional 6 inches increments in length.

3.11 Endurance Testing: Fastener chain and quick release stops shall be tested for endurance per specification requirements. Unless otherwise specified, all fastener chain shall meet a minimum endurance of 1000 cycles, and quick release shall meet 200 cycles. See Figure VIII for typical endurance machine description, requirements, and settings as required for chain testing.

A-A-55634

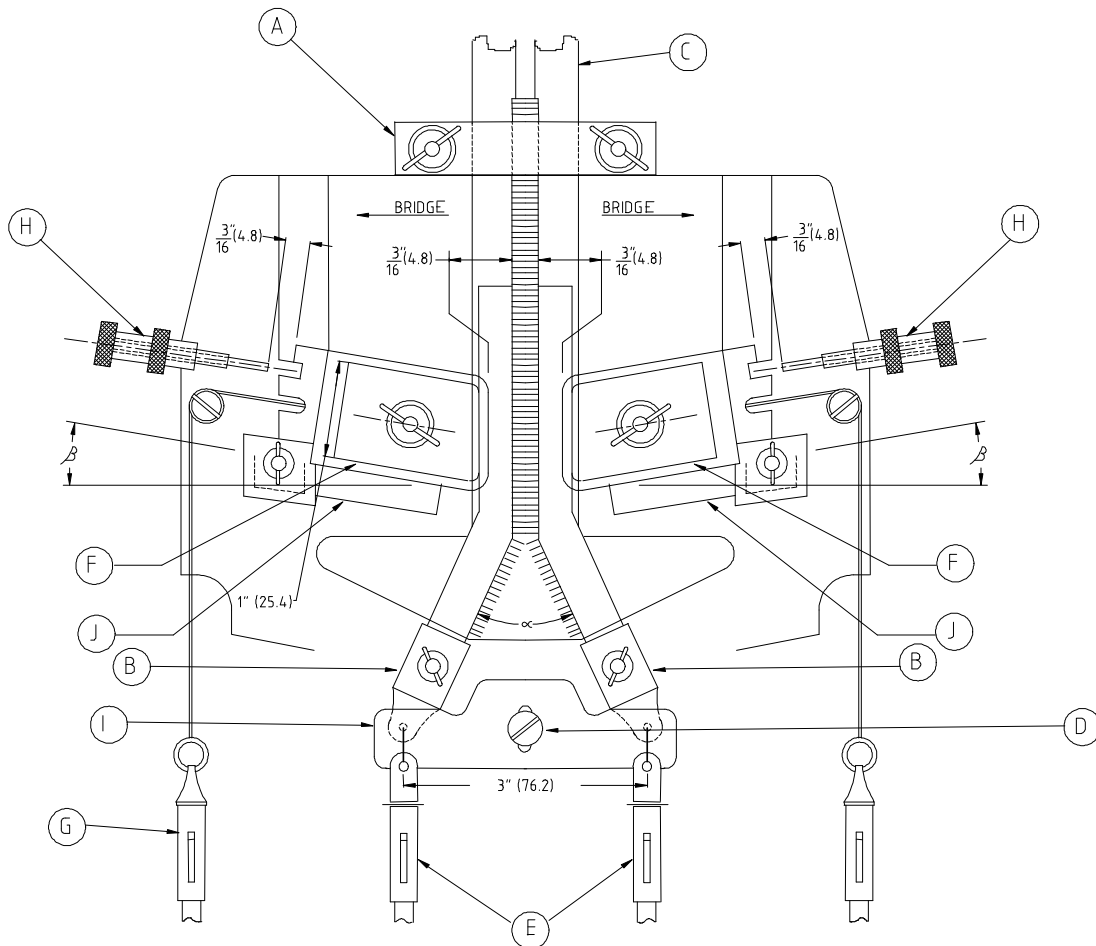

Fig. VIII- Endurance Machine

- This apparatus is an endurance testing machine which attempts to simulate various applications for different slide fasteners by applying a range of lateral and longitudinal forces to the chain.

A - clamp for closed end of slide fastener

B - clamp for open end of slide fastener

C - sample slide fastener

D - holding pin

E - spring balance for longitudinal direction

F - clamp for holding lateral side of slide fastener

G - spring balance for lateral direction

H - adjusting screw for moving distance of lateral clamp

I - rotary plate which acts as a medium for forces between slide fastener and balance

J - supporting plate for lateral holding clamp

- Two lateral clamps are located in the midst of reciprocating stroke on both sides of slide fastener.

- Gross weight of longitudinal clamps including B and I is 300 grams.

- Sample position 3 inches distance between the pivot of B, angle open (30 degrees), angle closed (60 degrees)

- Lateral clamps are inclined to be 10 degrees at the right to the chain

- Metric dimensions are noted in parentheses.

A-A-55634

- Endurance machine requirements are as follows:
 - A - the reciprocating stroke shall be 3 inches
 - B - unless otherwise specified, the number of cycles back and forth shall not be less than 500.
 - C - the lateral and longitudinal forces applied shall be in accordance with chain force table below for the different fastener sizes.
 - D - the fastener shall be opened and closed at a uniform rate of 30 cycles per minute.
 - E - the slider shall move approximately 3 inches for opening and 3 inches for closing.
 - F - there shall be no interference by any locking device on the slider during the opening and closing of the fastener.
 - G - for fasteners with multiple sliders, each shall be tested individually

FASTENER SIZE	FORCE, LATERAL LBS. (KGS)	FORCE, LONGITUDINAL LBS. (KGS)
1-2	1.5 (0.7)	1.1 (0.5)
3-4	2.2 (1.0)	1.5 (0.7)
5-7	3.5 (1.6)	3.1 (1.4)
8-9	5.3 (2.4)	4.0 (1.8)
10	6.6 (3.0)	5.1 (2.3)

Fig. VIII (cont'd)

4. Quality Assurance Provisions:

4.1 Product Conformance: The products provided shall meet salient characteristics of the commercial item description, conform to the producer's own drawings, specifications, standards and quality assurance practices and the same product shall be offered for sale in the commercial market. The government reserves the right to require proof of such conformance.

4.2 Test Methods: Table VII contains all applicable documents and test methods that are required for testing.

TABLE VII - TEST METHODS

a. Applicable Documents:

ASTM: American Society for Testing and Materials.

D2059 Resistance to Zippers to Salt Spray (Fog).
 D2060 Measuring Zipper Dimensions.
 D2061 Strength Test for Zippers.
 D2062 Operability of Zippers.

AATCC: American Association for Textile Chemists and Colorists.

TM3 Colorfastness to Bleaching with Chlorine.
 TM16-E Colorfastness to Light
 TM61 Colorfastness to Laundering, Home and Commercial: Accelerated
 TM111B Weather Resistance: Exposure to Natural Light and Weather.
 TM117 Colorfastness to Heat, Dry (Excluding Pressing).
 TM132 Colorfastness to Dry-cleaning

A-A-55634

TABLE VII - TEST METHODS (Continued)

<u>b. Physical Tests</u>	<u>ASTM Method</u>
<u>Crosswise Breaking Strength:</u>	
Chain	D2061
Separating Unit	D2061
<u>Holding Strength of Stops:</u>	
Bottom Stop	D2061
Separable Pin	D2061
Fixed Retainer	D2061
Top Stop	D2061
Slider locking strength (180 degrees)	D2061
<u>Operating Force:</u>	
Slider on Chain, Opening and Closing	D2062
Slider on Chain After Salt Spray (if applicable)	D2062
Element Pull-Off	D2061
Element Slippage - lengthwise	D2061
<u>Slider:</u>	
Cushioned Compression	D2061
Salt Spray Resistance (5% for 96 hours)	D2059
Length	D2060
Uniformity (straightness)	D2060
Flatness	D2060
Tape Width	D2060
Water Repellency	D2060
<u>Chain Width.</u> The closed chain width shall be measured to determine conformance of fastener size with the following procedure: Place the closed slide fastener or slide fastener chain on a horizontal working surface. Position the identification gauge with the outside faces of the anvils in flat contact with the tape. Close the jaws of the gauge slowly until they are in contact in a relaxed state, without physically compressing the shoulders of the elements and parallel to them on both stringers. Make five measurements on each specimen not less than 1 inch apart, reading the dial of the gauge to the nearest .001 inch.	
<u>Colorfastness Tests</u> (as appropriate)	
Chlorine Bleaching	<u>AATCC</u> Test Method 3
Weathering	Test Method 111 B (20 hrs.)
Wet Dry Cleaning	Test Method 132
Light	Test Method 16 (20 KJ for 20 hrs.)
Laundering/Black Oxidized Finish Durability (3X)	Test Method 61 (3A)
Dry Heat Sublimation	Test Method 117

5. Packaging

5.1 Unless otherwise specified, preservation, packing and marking shall be specified in the procurement document. Packaging shall be accordance with ASTM D3951.

A-A-55634

6. Notes

6.1 Unless otherwise specified, all dimensions are in inches.

6.2 Part Numbering System: For purposes of fastener identification, use the following system.Example: AA55634 - 00I 01 CEF A FS P 25Whereby AA55634 = Basic CID No.00I = Type Fastener: (See Tables I-IV for types)

00I = Fastener non-separating, non-reversible

0II = Fastener non-separating, reversible

III = Fastener separating, non-reversible

IV = Separating reversible

01 = Style, 01 thru 20 (See Tables I-IV for styles)CEF = Chain Type: CEF = Continuous Element Fastener

IEF = Individual Element Fastener

SSF = Self-Sealing Fastener

AGF = Anti-Gravity Fastener

A = Chain Material:

A = Aluminum

C = Brass, Black Oxidized

B = Brass

E = Aluminum, Enameled finish

N = Nickel

P = Plastic

FS = Fastener Size:

01 = 1-2

09 = 9

03 = 3-4

10 = 10

05 = 5-7

08 = 8

P = Tape Material:

P = Polyester, without water repellent (WR) finish

Q = Polyester, with WR finish

N = Nomex® (high-temperature-resistant polyamide) without WR finish

O = Other material as specified in the procurement document.

25 = Length in 1/4 inches, ($25 = 25/4 = 6\frac{1}{4}$ "*)**NOTE: Manufacturers are permitted to use either the direct length or the quarter inch system.*MILITARY INTERESTS:Custodians

Army - GL

Navy - AS

Air Force - 99

Review Activities

Army - MI

Air Force - 82

Navy-MC, SA, OS, NU

CIVIL AGENCY COORINATING ACTIVITIES:

GSA - FSS

VA - OSS

USDA - AFS

PREPARING ACTIVITY:

DLA - IS

(Project No.5325-0399)