



DOCUMENT 119-06

TELEMETRY GROUP

TELEMETRY APPLICATIONS HANDBOOK

**WHITE SANDS MISSILE RANGE
REAGAN TEST SITE
YUMA PROVING GROUND
DUGWAY PROVING GROUND
ABERDEEN TEST CENTER
NATIONAL TRAINING CENTER
ELECTRONIC PROVING GROUND**

**NAVAL AIR WARFARE CENTER WEAPONS DIVISION, PT. MUGU
NAVAL AIR WARFARE CENTER WEAPONS DIVISION, CHINA LAKE
NAVAL AIR WARFARE CENTER AIRCRAFT DIVISION, PATUXENT RIVER
NAVAL UNDERSEA WARFARE CENTER DIVISION, NEWPORT
PACIFIC MISSILE RANGE FACILITY
NAVAL UNDERSEA WARFARE CENTER DIVISION, KEYPORT**

**30TH SPACE WING
45TH SPACE WING
AIR FORCE FLIGHT TEST CENTER
AIR ARMAMENT CENTER
ARNOLD ENGINEERING DEVELOPMENT CENTER
BARRY M. GOLDWATER RANGE**

NATIONAL NUCLEAR SECURITY ADMINISTRATION (NEVADA)

**DISTRIBUTION A: APPROVED FOR PUBLIC RELEASE
DISTRIBUTION IS UNLIMITED**

This page intentionally left blank.

TELEMETRY APPLICATIONS HANDBOOK

MAY 2006

Prepared by

**TELEMETRY GROUP (TG)
RANGE COMMANDERS COUNCIL**

Published by

**Secretariat
Range Commanders Council
U.S. Army White Sands Missile Range,
New Mexico 88002-5110**

THIS DOCUMENT IS AVAILABLE ON THE
RANGE COMMANDERS WEBSITE AT
<http://www.jcte.jcs.mil/>

This page intentionally left blank.

TABLE OF CONTENTS

| | |
|--|------------|
| LIST OF FIGURES | iv |
| LIST OF TABLES | x |
| CHANGES TO THIS EDITION | xi |
| FOREWORD | xiii |
| PREFACE | xv |
| ACRONYMS AND INITIALISMS | xvii |
| | |
| CHAPTER 1: INTRODUCTION | 1-1 |
| 1.1 Telemetry Applications Handbook | 1-1 |
| 1.2 Telemetry Systems | 1-3 |
| | |
| CHAPTER 2: TELEMETRY SIGNALS AND NOISE | 2-1 |
| 2.1 Overview | 2-1 |
| 2.2 Non-R(NRZ PCM/FM) | 2-8 |
| 2.3 Biphase PCM/FM..... | 2-37 |
| 2.4 NRZ PCM/PM..... | 2-48 |
| 2.5 Biphase PCM/PM..... | 2-63 |
| 2.6 FQPSK, SOQPSK, and ARTM CPM | 2-83 |
| 2.7 Pulse Amplitude Modulation/Frequency Modulation..... | 2-96 |
| 2.8 FM/FM Telemetry | 2-120 |
| 2.9 Hybrid Systems | 2-168 |
| 2.10 Link Analysis | 2-173 |
| 2.11 Relay Systems | 2-181 |
| 2.12 Frequency Modulation (FM) Noise Characteristics..... | 2-184 |
| 2.13 Telemetry and GPS Compatibility | 2-202 |
| 2.14 Telemetry Signal Spacing | 2-209 |
| 2.15 References for Chapter 2..... | 2-219 |
| | |
| CHAPTER 3: TELEMETRY TRANSMITTING SYSTEM CHARACTERIZATION.... | 3-1 |
| 3.1 Introduction | 3-1 |
| 3.2 Overview of Telemetry Transmitting Systems | 3-1 |
| 3.3 Transmitting System Selection Guidelines | 3-2 |
| 3.4 References for Chapter 3..... | 3-7 |
| | |
| CHAPTER 4: TELEMETRY RECEIVING SYSTEM CHARACTERIZATION | 4-1 |
| 4.1 Overview | 4-1 |
| 4.2 Receiving Antennas..... | 4-3 |
| 4.3 Preamplifiers, Downconverters, and Multicouplers..... | 4-5 |
| 4.4 Telemetry Receivers and Diversity Combiners | 4-8 |
| 4.5 Magnetic Tape Recorders/Reproducers | 4-16 |
| 4.6 Data Synchronizers and Discriminators | 4-44 |
| 4.7 Receiving/Recording System Parameter Selection Guidelines..... | 4-48 |
| 4.8 Data Quality Monitoring | 4-50 |
| 4.9 References for Chapter 4..... | 4-59 |

GLOSSARY OF TERMS

INDEX

LIST OF FIGURES

| | | |
|--------------|--|------|
| Figure 1-1. | Telemetry transmitting system..... | 1-4 |
| Figure 1-2. | Telemetry receiving system. | 1-4 |
| Figure 2-1. | NRZ-L PCM/FM BER for three peak deviations. | 2-9 |
| Figure 2-2. | BEP versus E_b/N_o for NRZ-L PCM/FM with a peak deviation of 0.35 times the bit rate..... | 2-10 |
| Figure 2-3. | IF filter attenuation versus peak deviation..... | 2-13 |
| Figure 2-4. | BER for peak DEV/bit rate = 0.175, 0.25, and 0.35..... | 2-14 |
| Figure 2-5. | NRZ-L signal with PREMOD filter = bit rate..... | 2-16 |
| Figure 2-6. | NRZ-L signal with PREMOD filter = bit rate (CA)..... | 2-16 |
| Figure 2-7. | NRZ-L signal with PREMOD filter = bit rate/2 (CD)..... | 2-16 |
| Figure 2-8. | NRZ-L signal with PREMOD filter = bit rate/2 (CA)..... | 2-16 |
| Figure 2-9. | Effect of ac coupling on NRZ PCM/FM signal..... | 2-17 |
| Figure 2-10. | BEP for 10 Mb/s PCM/FM with various IF filters..... | 2-19 |
| Figure 2-11. | BER with AFC and with 100 kHz detuning..... | 2-20 |
| Figure 2-12. | BER versus IF SNR for several IF BWS..... | 2-22 |
| Figure 2-13. | BER with IF BW/bit rate = 1, 2, 3, and 6..... | 2-23 |
| Figure 2-14. | BER with IF BW bit rate = 1 and 1.5..... | 2-24 |
| Figure 2-15. | BER with video and PREMOD BWs = 0.5 and 1 bit rate..... | 2-25 |
| Figure 2-16. | BER with video BW = 0.5, 0.75, and 1 bit rate..... | 2-26 |
| Figure 2-17. | BER with video BW = 0.5, 0.75, and 1 bit rate..... | 2-27 |
| Figure 2-18. | NRZ PCM/FM spectrum (no PREMOD, peak DEV = 0.35 bit rate)..... | 2-30 |
| Figure 2-19. | RF spectrum PREMOD = 800 kHz CD peak DEV = 0.1 bit rate..... | 2-31 |
| Figure 2-20. | RF spectrum PREMOD = 800 kHz CD peak DEV = 0.175 bit rate..... | 2-31 |
| Figure 2-21. | RF spectrum PREMOD = 800 kHz CD peak DEV = 0.25 bit rate..... | 2-31 |
| Figure 2-22. | RF spectrum PREMOD = 800 kHz CD peak DEV = 0.35 bit rate..... | 2-31 |
| Figure 2-23. | RF spectrum PREMOD = 800 kHz CD peak DEV = 0.42 bit rate..... | 2-32 |
| Figure 2-24. | RF spectrum PREMOD = 800 kHz CD peak DEV = 0.50 bit rate..... | 2-32 |
| Figure 2-25. | RF spectrum PREMOD = 800 kHz CD peak DEV = 0.71 bit rate..... | 2-32 |
| Figure 2-26. | RF spectrum PREMOD = 800 kHz CD peak DEV = 1.00 bit rate..... | 2-32 |
| Figure 2-27. | RF spectrum PREMOD = 800 kHz CA peak DEV = 0.35 bit rate..... | 2-33 |
| Figure 2-28. | RF spectrum PREMOD = 560 kHz CD peak DEV = 0.35 bit rate..... | 2-33 |
| Figure 2-29. | RF spectrum PREMOD = 560 kHz CA peak DEV = 0.35 bit rate..... | 2-33 |
| Figure 2-30. | RF spectrum PREMOD = 400 kHz CA peak DEV = 0.35 bit rate..... | 2-33 |
| Figure 2-31. | RF spectrum PREMOD = 400 kHz CA peak DEV = 0.35 bit rate..... | 2-34 |
| Figure 2-32. | RF spectrum PREMOD = 800 kHz CD peak DEV = 0.35 bit rate..... | 2-34 |
| Figure 2-33. | RF spectrum PREMOD = 560 kHz RC peak DEV = 0.35 bit rate..... | 2-34 |
| Figure 2-34. | RF spectrum PREMOD-None peak DEV = 0.35 bit rate (3 kHz)..... | 2-34 |
| Figure 2-35. | NRZ PCM/FM AF spectrum with repeated 16-bit word..... | 2-35 |
| Figure 2-36. | NRZ PCM/FM RF spectrum with repeated 16-bit word (3/4 zeros)..... | 2-36 |
| Figure 2-37. | BER for IF BW = 2 and 6 times bit rate..... | 2-38 |
| Figure 2-38. | BER for peak DEV = 0.5, 0.65, and 0.8 bit rate for IF BW = 2 times bit rate..... | 2-39 |
| Figure 2-39. | BER for peak DEV = 0.5, 0.65, and 0.8 bit rate for IF BW = 3 times bit rate..... | 2-40 |
| Figure 2-40. | BER for PREMOD BW = 1, 1.4, and 2 bit rate..... | 2-42 |
| Figure 2-41. | BER for IF BW/bit rate = 1.4, 1.67, 2, and 2.5..... | 2-43 |
| Figure 2-42. | BER for IF BW/bit rate = 2, 3, and 6..... | 2-44 |

| | | |
|--------------|--|------|
| Figure 2-43. | Biphase PCM/FM RF spectrum (PREMOD=800 kHz CD, DEV=0.65 bit rate). | 2-45 |
| Figure 2-44. | Biphase PCM/FM RF spectrum (PREMOD=800 kHz CD, DEV=0.50 bit rate). | 2-46 |
| Figure 2-45. | RF spectrum PREMOD = 800 kHz CD peak DEV = 0.80 bit rate..... | 2-46 |
| Figure 2-46. | RF spectrum PREMOD = 800 kHz CA peak DEV = 0.65 bit rate..... | 2-46 |
| Figure 2-47. | RF spectrum PREMOD = 400 kHz CD peak DEV = 0.65 bit rate..... | 2-47 |
| Figure 2-48. | RF spectrum PREMOD = 400 kHz CA peak DEV = 0.65 bit rate..... | 2-47 |
| Figure 2-49. | BER for peak DEV = 80, 90, and 100 degrees. | 2-49 |
| Figure 2-50. | BER for peak DEC = 80, 90, and 100 degrees. | 2-50 |
| Figure 2-51. | BER for PREMOD = bit rate. | 2-51 |
| Figure 2-52. | BER for PREMOD = 0.7 bit rate. | 2-52 |
| Figure 2-53. | BER for PREMOD = 0.7 bit rate with F/S DET. | 2-53 |
| Figure 2-54. | BER for IF BW/bit rate = 2 and 12. | 2-56 |
| Figure 2-55. | BER for linear and limited IF signals. | 2-57 |
| Figure 2-56. | BER for video BW/BIT rate = 0.5, 1, and 2. | 2-58 |
| Figure 2-57. | RF spectrum 50 kb/s NRZ-M PCM/PM. | 2-60 |
| Figure 2-58. | RF spectrum 500 kb/s NRZ-M PCM/PM. | 2-60 |
| Figure 2-59. | RF spectrum 800 kb/s NRZ-N PCM/PM. | 2-61 |
| Figure 2-60. | RF spectrum PREMOD = 800 kHz CD peak DEV = 0.90 degrees..... | 2-61 |
| Figure 2-61. | RF spectrum PREMOD = 800 kHz CD peak DEV = 99 degrees..... | 2-62 |
| Figure 2-62. | RF spectrum PREMOD = 800 kHz CD peak DEV = 90 degrees (1s). | 2-62 |
| Figure 2-63. | RF spectrum PREMOD = 800 kHz CD peak DEV = 111 degrees (1s). | 2-62 |
| Figure 2-64. | RF spectrum PREMOD = 800 kHz CD peak DEV = 111 degrees..... | 2-62 |
| Figure 2-65. | RF spectrum PREMOD = 400 kHz CD peak DEV = 90 degrees..... | 2-63 |
| Figure 2-66. | RF spectrum PREMOD = 400 kHz CD peak DEV = 113 degrees..... | 2-63 |
| Figure 2-67. | RF spectrum PREMOD = 800 kHz CA peak DEV = 90 degrees..... | 2-63 |
| Figure 2-68. | RF spectrum PREMOD = 400 kHz CA peak DEV = 90 degrees..... | 2-63 |
| Figure 2-69. | 400 kb/s biphase PCM/PM RF spectrum (PREMOD = 800 kHz CD, DEV = 90 degrees. | 2-66 |
| Figure 2-70. | BER for peak DEV = 60, 75, and 90 degrees. | 2-67 |
| Figure 2-71. | BER for peak DEV = 60, 75, and 90 degrees. | 2-68 |
| Figure 2-72. | BER for peak DEV = 60 DEG and PREMOD = 1 and 2 bit rate. | 2-69 |
| Figure 2-73. | BER for peak DEV = 75 DEG and PREMOD = 1 and 2 bit rate. | 2-70 |
| Figure 2-74. | BER for peak DEV = 90 DEG and PREMOD = 1 and 2 bit rate. | 2-71 |
| Figure 2-75. | BER for IF BW=3 bit rate and PREMOD = 1 and 2 bit rate..... | 2-72 |
| Figure 2-76. | Biphase Signal with PREMOD BW = 2 times bit rate (CD)..... | 2-73 |
| Figure 2-77. | Biphase eye pattern with PREMOD BW = 1.4 bit rate. | 2-74 |
| Figure 2-78. | BER for peak DEV = 60 DEG. IF BW/bit rate = 2, 3, and 8. | 2-75 |
| Figure 2-79. | BER for peak DEV = 75 DEG, IF BW/bit rate = 2, 3, 8, and 20. | 2-76 |
| Figure 2-80. | BER for peak DEV = 90 DEG, IF BW/BIT Rate = 2, 3, and 20..... | 2-77 |
| Figure 2-81. | 400 kb/s biphase PCM/PM RF spectrum (PREMOD = none, DEV = 75 degrees). | 2-78 |
| Figure 2-82. | 400 kb/s biphase PCM/PM RF spectrum (20 MHz bandwidth). | 2-79 |
| Figure 2-83. | RF spectrum PREMOD = 800 kHz CD peak DEV = 60 degrees..... | 2-80 |
| Figure 2-84. | RF spectrum PREMOD = 800 kHz CD peak DEV = 60 degrees..... | 2-80 |
| Figure 2-85. | RF spectrum PREMOD = 400 kHz CD peak DEV = 60 degrees..... | 2-80 |
| Figure 2-86. | RF spectrum PREMOD = 400 kHz CA peak DEV = 60 degrees..... | 2-80 |
| Figure 2-87. | RF spectrum PREMOD = 800 kHz CD peak DEV = 75 degrees..... | 2-80 |
| Figure 2-88. | RF spectrum PREMOD = 800 kHz CA peak DEV = 75 degrees..... | 2-80 |

| | | |
|---------------|---|-------|
| Figure 2-89. | RF spectrum PREMOD = 400 kHz CD peak DEV = 75 degrees..... | 2-81 |
| Figure 2-90. | RF spectrum PREMOD = 400 kHz CA peak DEV = 75 degrees..... | 2-81 |
| Figure 2-91. | RF spectrum PREMOD = 800 kHz CD peak DEV = 90 degrees..... | 2-82 |
| Figure 2-92. | RF spectrum PREMOD = 800 kHz CA peak DEV = 90 degrees..... | 2-82 |
| Figure 2-93. | RF spectrum PREMOD = 400 kHz CD peak DEV = 90 degrees..... | 2-82 |
| Figure 2-94. | RF spectrum PREMOD = 400 kHz CA peak DEV = 90 Degrees..... | 2-82 |
| Figure 2-95. | FQPSK-JR baseband signal generator..... | 2-84 |
| Figure 2-96. | FQPSK wavelet eye diagram..... | 2-86 |
| Figure 2-97. | FQPSK-B I & Q eye diagrams (at input to IQ modulator)..... | 2-86 |
| Figure 2-98. | FQPSK-B vector diagram..... | 2-87 |
| Figure 2-99. | 5 Mb/s FQPSK-JR spectrum with random input data and small (blue) and large (red) modulator errors..... | 2-87 |
| Figure 2-100. | FQPSK-B spectrum with all "O's" as the input signal..... | 2-87 |
| Figure 2-101. | BEP versus E_b/N_0 for FQPSK-JR..... | 2-88 |
| Figure 2-102. | Basic SOQPSK block diagram..... | 2-88 |
| Figure 2-103. | SOQPSK transmitter..... | 2-90 |
| Figure 2-104. | Measured SOQPSK-TG phase trajectory..... | 2-91 |
| Figure 2-105. | SOQPSK-TG power spectrum (5 mb/s)..... | 2-91 |
| Figure 2-106. | BEP versus E_b/N_0 performance of 5 Mb/s SOQPSK-TG..... | 2-92 |
| Figure 2-107. | BEP versus E_b/N_0 performance of 5 Mb/s SOQPSK-TG with acceptable phase noise (red line) and excess phase noise (blue line)..... | 2-92 |
| Figure 2-108. | SOQPSK-TG BEP performance with various IF bandwidths..... | 2-92 |
| Figure 2-109. | Conceptual CPM modulator..... | 2-94 |
| Figure 2-110. | Power spectrum of 5 MB/S ARTM CPM..... | 2-95 |
| Figure 2-111. | BEP versus E_b/N_0 performance of 5 Mb/s ARTM CPM..... | 2-95 |
| Figure 2-112. | NRZ PAM signal with flat-top sampling..... | 2-97 |
| Figure 2-113. | NRZ PAM Signal with Natural Sampling..... | 2-98 |
| Figure 2-114. | Measured and Calculated PAM Output SNR Versus IF SNR..... | 2-102 |
| Figure 2-115. | Measured and calculate PAM SNR for 0, 50, and 100 percent levels..... | 2-103 |
| Figure 2-116. | PAM DECOM Output for 15 dB IF SNR with 50% FS Modulation..... | 2-104 |
| Figure 2-117. | PAM DECOM output for 12 dB IF SNR with 50 percent FS modulation..... | 2-105 |
| Figure 2-118. | PAM DECOM output for 9 dB IF SNR with 0 percent FS modulation..... | 2-106 |
| Figure 2-119. | PAM DECOM output for 9 dB IF SNR with 50 percent FS modulation..... | 2-107 |
| Figure 2-120. | PAM DECOM output for 9 dB IF SNR with 100 percent FS modulation..... | 2-108 |
| Figure 2-121. | PAM DECOM output for 6 dB IF SNR with 50 percent FS modulation..... | 2-109 |
| Figure 2-122. | PAM DECOM output for 12 dB IF SNR triangle modulation..... | 2-110 |
| Figure 2-123. | PAM DECOM output for 9 dB IF SNR with triangle modulation..... | 2-111 |
| Figure 2-124. | PAM DECOM output for 6 dB IF SNR with triangle modulation..... | 2-112 |
| Figure 2-125. | NRZ PAM baseband spectrum..... | 2-114 |
| Figure 2-126. | PAM/FM RF spectrum with peak deviation = 50 kHz..... | 2-115 |
| Figure 2-127. | PAM/FM RF spectrum with peak deviation = 125 kHz..... | 2-116 |
| Figure 2-128. | PAM/FM RF spectrum with peak deviation = 250 kHz..... | 2-117 |
| Figure 2-129. | PAM/FM RF spectrum with No Premodulation Filter..... | 2-118 |
| Figure 2-130. | 50 kCH/s PAM/FM RF spectrum..... | 2-119 |
| Figure 2-131. | FM/FM system block diagram..... | 2-121 |
| Figure 2-132. | FM/FM SNR for center frequency and upper band edge signals..... | 2-125 |
| Figure 2-133. | FM Noise with 3-pole Bessel LPF..... | 2-126 |
| Figure 2-134. | FM Noise with 7-pole Bessel LPF..... | 2-127 |
| Figure 2-135. | FM Noise with 3-pole Butterworth LPF (-0.5 dB)..... | 2-128 |
| Figure 2-136. | FM Noise with 7-pole Butterworth LPF..... | 2-129 |

| | | |
|---------------|---|-------|
| Figure 2-137. | FM Noise with 7-pole Butterworth LPF (-3 dB). | 2-130 |
| Figure 2-138. | FM Noise for several peak deviations. | 2-131 |
| Figure 2-139. | PMW measured and calculated SNRs with Brickwall Filters. | 2-132 |
| Figure 2-140. | CBW measured and calculated SNRs with Brickwall Filters. | 2-133 |
| Figure 2-141. | PBW measured and calculated SNRs with correction factors. | 2-134 |
| Figure 2-142. | CBW measured and calculated SNRs with LPF correction factors. | 2-135 |
| Figure 2-143. | Measured and calculated SNRs with correction factors (D = 1). | 2-136 |
| Figure 2-144. | Measured and calculated SNRs with correction factors (D = 4). | 2-137 |
| Figure 2-145. | Tape recorder output with normal record level CBW input. | 2-144 |
| Figure 2-146. | Tape recorder output with (normal record level) /2 CBW input. | 2-145 |
| Figure 2-147. | CBW spectrum with no preemphasis. | 2-146 |
| Figure 2-148. | CBW spectrum with 6 dB/octave preemphasis. | 2-147 |
| Figure 2-149. | PBW spectrum with no preemphasis. | 2-148 |
| Figure 2-150. | PBW spectrum with 9 dB/octave preemphasis. | 2-149 |
| Figure 2-151. | PBW spectrum with 9 dB/octave preemphasis and 10 percent minimum amplitude. | 2-150 |
| Figure 2-152. | FM spectrum with single sine wave modulation and MI = 1. | 2-153 |
| Figure 2-153. | FM spectrum with single sine wave modulation and MI = 2.405. | 2-154 |
| Figure 2-154. | FM spectrum with two sine wave modulation and MI = 1. | 2-157 |
| Figure 2-155. | FM spectrum with two sine wave modulation and MI = 1 and MI = 2.4. .. | 2-158 |
| Figure 2-156. | FM spectrum with three sine wave modulation and MI = 0.6. | 2-159 |
| Figure 2-157. | FM spectrum with three sine wave modulation and MI = 1 and MI = 2.4. | 2-160 |
| Figure 2-158. | Measured and theoretical NPRs (1000 kHz IF, 160 kHz deviation). | 2-163 |
| Figure 2-159. | Measured and theoretical NPRs (1500 kHz IF, 160 kHz deviation). | 2-164 |
| Figure 2-160. | Measured and theoretical NPRs (500 kHz IF, 100 kHz deviation). | 2-165 |
| Figure 2-161. | Measured and theoretical NPRs (1000 kHz IF, 100 kHz deviation). | 2-166 |
| Figure 2-162. | Measured and theoretical NPRs (1500 kHz IF, 100 kHz deviation). | 2-167 |
| Figure 2-163. | Measured and theoretical NPRs (1500 kHz IF, 200 kHz deviation). | 2-168 |
| Figure 2-164. | Baseband spectrum 256 kb/s NRZ with 2 SCOSs. | 2-170 |
| Figure 2-165. | RF spectrum 256 kb/s NRZ PCM/FM with 2 SCOs. | 2-171 |
| Figure 2-166. | BER versus IF BW for 256 kb/s NRZ PCM/FM and 2 SCOs. | 2-172 |
| Figure 2-167. | Block diagram of telemetry link. | 2-174 |
| Figure 2-168. | Typical radio horizon for transmitter less than 10,000 feet above MLE. ... | 2-175 |
| Figure 2-169. | Typical radio horizon for transmitter less than 100,000 feet above MLE. .. | 2-176 |
| Figure 2-170. | Block diagram of translation relay link. | 2-183 |
| Figure 2-171. | Block diagram of demodulation/remodulation relay link. | 2-184 |
| Figure 2-172. | Fluctuation noise vector diagram for N=0.2S. | 2-185 |
| Figure 2-173. | IF Amplitude (N=0.2s). | 2-185 |
| Figure 2-174. | Demodulator output for N=0.2S. | 2-185 |
| Figure 2-175. | IF filter frequency response (Filter A). | 2-187 |
| Figure 2-176. | IF filter frequency response (Filter B). | 2-187 |
| Figure 2-177. | IF filter frequency response (Filter C). | 2-187 |
| Figure 2-178. | Fluctuation noise. | 2-188 |
| Figure 2-179. | Receiver video noise power spectral density. | 2-189 |
| Figure 2-180. | Vector diagram of pop noise (N=1.1S). | 2-190 |
| Figure 2-181. | IF amplitude (N=1.1S). | 2-190 |
| Figure 2-182. | Demodulator output (N=1.1S). | 2-190 |
| Figure 2-183. | Noise pop (Upper trace video BW = 1 MHz) and IF signal. | 2-191 |
| Figure 2-184. | Pop noise (Upper trace video BW = 500 kHz) and IF signal. | 2-192 |
| Figure 2-185. | Pop noise with IF signal = 10.25 MHz. | 2-193 |

| | | |
|---------------|--|-------|
| Figure 2-186. | Pop noise with IF signal = 9.75 MHz. | 2-194 |
| Figure 2-187. | Noise pop away from center frequency. | 2-195 |
| Figure 2-188. | Noise pop with area = 2 PI. | 2-196 |
| Figure 2-189. | Noise pop with Area > 2 PI. | 2-197 |
| Figure 2-190. | Superposition of several noise pops (IF bandwidth = 1 MHz). | 2-198 |
| Figure 2-191. | Superposition of several noise pops (IF bandwidth = 10 MHz). | 2-199 |
| Figure 2-192. | Doublet. | 2-200 |
| Figure 2-193. | Doublet (upper trace) and IF signal. | 2-201 |
| Figure 2-194. | Test setup. | 2-203 |
| Figure 2-195. | Spectrum analyzer plots at GPS LNA output. | 2-204 |
| Figure 2-196. | Laboratory test setup. | 2-205 |
| Figure 2-197. | Excess power levels with transmitter on (10 dB attenuation). | 2-206 |
| Figure 2-198. | Transmission noise power at 1575.4 MHz. | 2-206 |
| Figure 2-199. | DSQ- 50 telemetry transmitter + BPF + LNA. | 2-207 |
| Figure 2-200. | GPS satellite C/N values with DSQ-50A and bandstop filter. | 2-208 |
| Figure 2-201. | Block diagram of L-band telemetry and GPS systems designed to minimize interference. | 2-209 |
| Figure 2-202. | Test setup. | 2-210 |
| Figure 2-203. | Signal spectra. | 2-211 |
| Figure 2-204. | ACI effects with 5 Mbps PCM/FM. | 2-211 |
| Figure 2-205. | 5 MBPS PCM/FM with various interferers. | 2-212 |
| Figure 2-206. | 5 Mbps SOQPSK-TG. | 2-212 |
| Figure 2-207. | 5 Mbps ARTM CPM. | 2-212 |
| Figure 2-208. | 8 Mbps SOQPSK-TG with 8 MHz IF BW. | 2-212 |
| Figure 2-209. | 8 Mbps SOQPSK-TG with 16 MHz IF BW. | 2-212 |
| Figure 2-210. | 8 Mbps SOQPSK-TG with 8 MHz IF BW and various C/I ratios. | 2-213 |
| Figure 2-211. | 8 Mbps SOQPSK-TG with 16 MHz IF BW and various C/I ratios. | 2-213 |
| Figure 2-212. | 1 Mbps PCM/FM with I = 15 mbps PCM/FM. | 2-213 |
| Figure 2-213. | 20 Mbps PCM/FM with I = 15 mbps PCM/FM. | 2-213 |
| Figure 2-214. | Minimum frequency separation. | 2-214 |
| Figure 2-215. | Minimum frequency separation for 4 Mb/s PCM/FM. | 2-214 |
| Figure 2-216. | 10 mb/s NRZ PCM/FM with receiver with typical RLC filters assumed. | 2-217 |
| Figure 2-217. | 10 mb/s NRZ PCM/FM with multi-symbol detector assumed. | 2-217 |
| Figure 2-218. | 10 mb/s SOQPSK-TG or FQPSK-JR. | 2-217 |
| Figure 2-219. | 10 mb/s ARTM cpm. | 2-217 |
| Figure 2-220. | Co-channel interference test results. | 2-218 |
| Figure 3-1. | Probability of detecting sync pattern with BER = 0.1. | 3-4 |
| Figure 3-2. | Probability of detecting sync pattern with BER = 0.01. | 3-5 |
| Figure 3-3. | Probability of detecting false sync pattern. | 3-6 |
| Figure 4-1. | Simplified telemetry receive/record station. | 4-3 |
| Figure 4-2. | Antenna gain versus diameter (50 percent efficiency). | 4-4 |
| Figure 4-3. | Antenna beamwidth versus diameter (50 percent efficiency). | 4-5 |
| Figure 4-4. | Receiving system noise temperature. | 4-7 |
| Figure 4-5. | Sample receiver IF filter amplitude response. | 4-10 |
| Figure 4-6. | Combiner improvement relative to best input signal. | 4-12 |
| Figure 4-7. | Combiner improvement relative to fixed input signal. | 4-13 |
| Figure 4-8. | Combiner degradation from optimum with 3 dB weighting error. | 4-14 |
| Figure 4-9. | Combiner degradation from optimum versus phase error. | 4-14 |
| Figure 4-10. | Azimuth error illustration. | 4-19 |
| Figure 4-11. | Azimuth error loss versus frequency (120 ips). | 4-20 |

| | | |
|--------------|---|------|
| Figure 4-12. | Reproduce gap loss illustration. | 4-22 |
| Figure 4-13. | Reproduce gap loss versus frequency. | 4-23 |
| Figure 4-14. | Recording without bias. | 4-24 |
| Figure 4-15. | Recording with dc-bias. | 4-25 |
| Figure 4-16. | Recording with ac-bias. | 4-26 |
| Figure 4-17. | Effects of over-bias and under-bias recording (input level constant). | 4-27 |
| Figure 4-18. | Equalizer Input at 30 IPS. | 4-28 |
| Figure 4-19. | Reproducer output at 30 IPS. | 4-29 |
| Figure 4-20. | Methods for recording telemetry signals. | 4-31 |
| Figure 4-21. | BER with 300 kb/s and 450 and 90 kHz PRE-D. | 4-32 |
| Figure 4-22. | BER with and without recording. | 4-33 |
| Figure 4-23. | BER for 900 kb/s and 900 kHz PRE-D. | 4-34 |
| Figure 4-24. | Noise PSDs for IF and PRE-D signals. | 4-35 |
| Figure 4-25. | BER for 900 kb/s with 900 and 1800 kHz PRE-D. | 4-36 |
| Figure 4-26. | Upconversion versus tape carrier demodulation. | 4-38 |
| Figure 4-27. | BER for 1200 kb/s PCM/PM with 900 and 1200 kHz PRE-D. | 4-39 |
| Figure 4-28. | BER for 300, 450, and 600 kb/s biphase PCM/PM. | 4-40 |
| Figure 4-29. | Randomizer. | 4-42 |
| Figure 4-30. | Derandomizer. | 4-43 |
| Figure 4-31. | Probability of detecting sync pattern with BER = 0.1. | 4-46 |
| Figure 4-32. | Probability of Detecting Sync Pattern with BER = 0.01. | 4-47 |
| Figure 4-33. | Probability of detecting false sync pattern. | 4-48 |
| Figure 4-34. | Oscilloscope eye patterns at various IF SNRs. bit rate = 1 Mb/s and IF BW = 1500 kHz. | 4-52 |
| Figure 4-35. | Oscilloscope eye patterns at various IF SNRs. Bit rate 1 Mb/s. | 4-53 |
| Figure 4-36. | Receiver IF Spectrum at 18 dB IF SNR. | 4-54 |
| Figure 4-37. | Receiver IF Spectrum at 14 dB IF SNR. | 4-55 |
| Figure 4-38. | Receiver IF Spectrum at 10 dB IF SNR. | 4-56 |
| Figure 4-39. | Receiver IF Spectrum at 6 dB IF SNR. | 4-57 |
| Figure 4-40. | Receiver IF spectrum at 2 dB IF SNR. | 4-58 |

LIST OF TABLES

| | | |
|-------------|--|-------|
| Table 2-1. | RF Spectral Characteristics for Various Peak Definitions..... | 2-32 |
| Table 2-2. | RF Spectral Characteristics for Various Premodulation Filters..... | 2-33 |
| Table 2-3. | IF SNR (dB) for 10^{-5} BER With NRZ-M PCM/PM and Various Combinations of Bit Rate, Peak Deviation, IF Bandwidth, and Premodulation Filter. | 2-54 |
| Table 2-4. | FQPSK-JR Shaping Filter Definition | 2-85 |
| Table 2-5. | FQPSK-B and FQPSK-JR Phase Map..... | 2-85 |
| Table 2-6. | SOQPSK-TG Parameters..... | 2-90 |
| Table 2-7. | SOQPSK Pre-Coding Table for IRIG-106 Compatibility | 2-91 |
| Table 2-8. | Dibit to Impulse Area Mapping | 2-94 |
| Table 2-9. | SNR Improvement for Various Low-Pass Filters After Docummutated Output (Compared to Raw Decommuted Output). | 2-101 |
| Table 2-10. | FM Sideband Power Versus MI..... | 2-151 |
| Table 2-11. | Coefficients Of Equation for Using J_0/J_1 (dB) To Calculate MI for $MI < 1.6$ | 2-155 |
| Table 2-12. | Coefficients for Frequency Separation Calculation | 2-215 |
| Table 4-1. | Typical Improvement of Polarization Diversity Compared to Single Channel for Missile Antennas. | 4-12 |

CHANGES TO THIS EDITION

With the following changes, Document 119-88, Vol. 1 has been revised and reissued under number 119-06. The major sections of the old document have been converted into four chapters for ease of reading. Paragraph and page numbering have been changed throughout to conform to RCC formatting conventions. Changes noted below are highlighted in the text with the following icons:

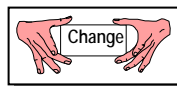

Section 2.0 (Telemetry Terminology) has been eliminated and contents were moved as follows:

The Glossary of Terms was moved to precede the index at the end of the document.
The Acronyms and Abbreviations section was moved to the beginning of the document.

Section 3.0 (Telemetry Signals and Noise) is now Paragraph 2.1 (Overview). Updates have been made to the summaries of PCM characteristics and two summary paragraphs have been added as follows:

Paragraph 2.1.5: FQPSK and SOQPSK Summary.
Paragraph 2.1.6: ARTM Summary.

Section 3.5 (Phase Shift Keying) has been replaced with Paragraph 2.6 (FQPSK, SOQPSK, and ARTM CPM).

Note: If you have any comments regarding this edition, please contact the Secretariat, Range Commanders Council.

Secretariat, Range Commanders Council
CSTE-DTC-WS-RCC
100 Headquarters Avenue
White Sands Missile Range, NM 88002

This page intentionally left blank.

FOREWORD

For many years, the Telemetry Group (TG) of the Range Commanders Council (RCC) has recognized the continuing need for guidelines on practical telemetry applications. Guidelines are needed by telemetry (TM) systems planners, designers, and operators in their efforts to identify important systems parameters, solve system problems, and establish effective preventive maintenance procedures for improving overall telemetry system performance. Recognizing that these needs must be met, the Telemetry Group (TG) of the RCC developed this Telemetry Applications Handbook.

The demands placed upon systems planners, designers, and operators have changed significantly in recent years because of the increasingly complex requirements to monitor the activities of rapidly advancing space, air, ground, and ocean vehicles. State-of-the-art developments in the field of electronics have provided the means through which systems have kept pace with technological changes. Although there have been many publications in the field of telemetry, none is directly oriented toward practical application. Supportive practical information, which provides the necessary operational tools, has not kept pace with the demands placed upon telemetry systems personnel. Therefore, the major goal of the Telemetry Applications Handbook is to provide a practical application baseline that will improve overall telemetry system performance. The guidelines provided will become the tools for telemetry systems personnel to achieve the intended goals of improved performance and compatibility.

Since this handbook is of significant importance to the personnel involved with the design, operation, and maintenance of telemetry systems, a great deal of concern was given to format, content, and level of text information. The final document is the result of Telemetry Group Committee reviews, inputs received through a telemetry oriented questionnaire/survey, and extensive laboratory testing. The topics in this document are organized along the telemetry signal progression from the source signal through the system to recovery of the source signal. In general, the handbook includes information on signal and noise considerations, transmission requirements, and reception requirements. Discussions of these general categories are accompanied by illustrations such as systems block diagrams, graphs, and photos.

This page intentionally left blank.

PREFACE

This handbook provides practical information about telemetry (TM) system engineering and is intended to be useful to both system designers and operators. The main topic areas discussed include parameter optimization for the best data quality, radio frequency spectral occupancy, and the relationship of theory to "real-world" telemetry problems. The book is organized into the following four chapters:

1. Introduction
2. Telemetry signals and noise
3. Telemetry transmitting system characterization
4. Telemetry-receiving system characterization

This document is complemented by a companion series, RCC Document 106, *Telemetry Standards*, and RCC Document 118, *Test Methods For Telemetry Systems and Subsystems, Volume 1, Test Methods For Vehicle Telemetry Systems*. The policy of the Telemetry Group is to update the telemetry standards and test methods as required, being consistent with advances in the state of the art. To determine the current revision status, contact the RCC Secretariat.

The Telemetry Group would like to acknowledge production of this document for the RCC by the author:

Mr. Eugene Law
Member, Telemetry Group (TG)
NAVAIR Point Mugu, Code 543000e
575 I Ave Ste 1, Point Mugu, CA 93042-5049
Phone: DSN 351-0164/Com (805) 989-0164
Fax: DSN 351-0760/Com (805) 989-0760
E-Mail: Eugene.Law@Navy.Mil

Please direct any questions to:

Secretariat, Range Commanders Council
ATTN: CSTE-DTC-WS-RCC
100 Headquarters Avenue
White Sands Missile Range, New Mexico 88002-5110
Telephone: (505) 678-1107, DSN 258-1107
E-mail rcc@wsmr.army.mil

This page intentionally left blank.

ACRONYMS AND INITIALISMS

-A-

| | |
|----------|---------------------------------------|
| ac | Alternating current |
| A/D, ADC | Analog-to-digital converter |
| AFC | Automatic frequency control |
| AGC | Automatic gain control |
| AM | Amplitude modulation |
| ANSI | American National Standards Institute |
| APC | Automatic phase control |
| ARTM | Advanced Range Telemetry |
| AWGN | Additive white Gaussian noise |
| AZ | Azimuth |

-B-

| | |
|-------------------|---|
| BCD | Binary coded decimal |
| BEP | Bit error probability |
| BER | Bit error rate |
| B ϕ -L,-M,-S | Biphase level, mark, space |
| BITE | Built-in test equipment |
| BIT SYNC | Bit synchronizer |
| BPF | Bandpass filter |
| BPIF | Bandpass input filter |
| bps, b/s | Bit per second |
| BPSK | Binary phase shift keying |
| BR | Bit rate |
| BSP | Bit slippage probability |
| BSR | Bit slippage rate |
| BSSC | Bit synchronizer and signal conditioner |
| BW | Bandwidth |

-C-

| | |
|-------|---|
| CA | Constant amplitude |
| CBW | Constant bandwidth |
| CD | Constant delay |
| CMOS | Complimentary metal-oxide-semiconductor |
| CNR | Carrier-to-noise ratio |
| CPFSK | Continuous phase frequency shift keying |
| CPM | Continuous phase modulation |
| cps | Cycles per second |
| CRC | Cyclical redundancy check |

-D-

| | |
|-----------------|--|
| D/A, DAC | Digital-to-analog converter |
| dB | Decibel |
| dBc | Decibels referenced to the carrier level |
| dB _i | Decibels referenced to isotropic |
| dBm | Decibels referenced to one milliwatt |
| dBV | Decibels referenced to one volt |
| dBW | Decibels referenced to one watt |
| dc | Direct current |
| DEM0D | Demodulator |
| DEM0X | Demultiplexer |
| DM | Delay modulation, aka Miller code, modified frequency modulation |
| DSV | Digital sum variation |

-E-

| | |
|-----------|---|
| E_b/N_0 | Ratio of signal energy per bit divided by the noise power spectral density per Hz |
| ECC | Error-correction coding |
| ECL | Emitter coupled logic |
| EDAC | Error detection and correction |
| ENPBW | Equivalent noise power bandwidth |
| EUC | Engineering unit conversion |

-F-

| | |
|-------|--|
| FDM | Frequency division multiplexing |
| FEC | Forward error correction |
| FFI | Frame format identification |
| FIFO | First-in first-out |
| FM | Frequency modulation |
| FM/FM | Frequency modulation/frequency modulation |
| FMG | Frequency Management Group |
| FQPSK | Feher's patented quadrature phase shift keying |
| FRPI | Flux reversals per inch |
| F/S | Filter and sample |
| FSK | Frequency shift keying |

-G-

| | |
|-----|---------------------------|
| GCR | Group code for recording |
| GHz | Gigahertz |
| GPS | Global Positioning System |
| G/T | Gain/noise temperature |

-H-

| | |
|------|--------------------------------|
| HDDR | High density digital recording |
| HE | High energy |
| HR | High resolution |
| Hz | Hertz |

-I-

| | |
|----------|--|
| IC | Integrated circuit |
| I/D | Integrate and dump |
| IF | Intermediate frequency |
| IFM | Incidental frequency modulation |
| IFT | International Foundation for Telemetry |
| iNET | Integrated Network Enhanced Telemetry |
| in/s | Inches per second |
| I/O | Input/output |
| ips, IPS | Inches per second |
| IRIG | Inter-Range Instrumentation Group |
| I/S | Interference-to-signal ratio |
| ISI | Intersymbol interference |
| ITC | International Telemetry Conference |
| ITDE | Inter-track displacement error |
| ITU | International Telecommunications Union |

-J-

| | |
|----------|---|
| $J_i(x)$ | i^{th} order Bessel function of the first kind |
|----------|---|

-K-

| | |
|------------|-------------------|
| kbi, kb/in | Kilobits per inch |
| kHz | Kilohertz |

-L-

| | |
|-----------|---------------------------------|
| LBE | Lower band edge |
| LBW | Loop bandwidth |
| LHC, LHCP | Left hand circular polarization |
| LNA | Low noise amplifier |
| LOS | Line of sight, loss of signal |
| LPF | Low-pass Filter |
| LSB | Least significant bit |

-M-

| | |
|----------------|--------------------------------|
| M ² | Miller squared |
| MCT | Manufacturers center line tape |
| MHz | Megahertz |
| MI | Modulation index |
| μs | Microsecond |
| ms | Millisecond |
| MSB | Most significant bit |
| MUX | Multiplexer |

-N-

| | |
|---------------|---|
| NLT | Noise loading test |
| NPR | Noise power ratio |
| NPRF, NPRO | Noise power ratio floor |
| NPRI | Noise power ratio intermodulation |
| NRL | Normal record level |
| NRZ-L, -M, -S | Non-return-to-zero level, mark, space |
| ns | Nanosecond |
| NTIA | National Telecommunication and Information Administration |

-O-

| | |
|-------|--------------------------------------|
| OQPSK | Offset Quadrature Phase Shift Keying |
|-------|--------------------------------------|

-P-

| | |
|-----------|---|
| PAM | Pulse amplitude modulation |
| PAM/FM | Pulse amplitude modulation/frequency modulation |
| PBW | Proportional bandwidth |
| PCB | Printed circuit board |
| PCM | Pulse code modulation |
| PCM/FM | Pulse code modulation/frequency modulation |
| PCM/FM/FM | Pulse code modulation/frequency modulation/frequency modulation |
| PCM/PM | Pulse code modulation/phase modulation |
| PDM | Pulse duration modulation |
| PFD | Power flux density |
| PLL | Phase locked loop |
| PM | Phase modulation |
| PN | Pseudo noise |
| POST-D | Post detection |
| p-p | Peak-to-peak |
| ppm | Parts per million |
| PPM | Pulse position modulation |
| PREAMP | Preamplifier |

| | |
|--------|-------------------------------|
| PRE-D | Predetection |
| PREMOD | Premodulation |
| PR | Pseudo random |
| PRN | Pseudo random noise |
| PRS | Pseudo random sequence |
| PROM | Programmable read only memory |
| PSK | Phase shift keying |
| PWA | Printed wiring assembly |

-Q-

| | |
|------|-------------------------------|
| QPSK | Quadrature phase shift keying |
|------|-------------------------------|

-R-

| | |
|-----------|---------------------------------------|
| RAM | Random access memory |
| RCC | Range Commanders Council |
| RCD | Record |
| RCDR | Recorder |
| RCVR | Receiver |
| RDP | Radiation density pattern |
| RCD/REPRO | Record/reproduce, recorder/reproducer |
| REPRO | Reproduce |
| RF | Radio frequency |
| RHC, RHCP | Right hand circular polarization |
| rms | Root-mean-square |
| RNRZ | Randomized non-return-to-zero |
| ROM | Read only memory |
| RSC | Reed-Solomon Code |
| RZ | Return-to-zero |

-S-

| | |
|--------|---|
| SCO | Subcarrier oscillator |
| SFID | Subframe identification |
| S/H | Sample and hold |
| S/I | Signal-to-interference (ratio) |
| SIM | Simulated |
| SNR | Signal-to-noise ratio |
| SOQPSK | Shaped offset quadrature phase shift keying |
| SR | Standard resolution |
| SRL | Standard record level |
| SYNC | Synchronization |

-T-

| | |
|---------|--|
| TBE | Time base error |
| TCRG | Time code reader/generator |
| TDM | Time division multiplex |
| TG | Telemetry Group |
| THIC | Tape Head Interface Committee |
| TLM, TM | Telemetry, telemeter |
| TP | Test point |
| TPI | Tracks per inch |
| TSC | Tape speed compensation |
| TSCC | Telemetry standards coordinating committee |
| TTL | Transistor-transistor logic |

-U-

| | |
|-----|----------------------|
| UBE | Upper band edge |
| UHF | Ultra high frequency |

-V-

| | |
|------|---------------------------------------|
| VCO | Voltage controlled oscillator |
| VCXO | Voltage controlled crystal oscillator |
| VHF | Very high frequency |
| VSWR | Voltage standing wave ratio |

-W-

| | |
|-----|------------------------|
| WRT | Working reference tape |
|-----|------------------------|

-X-

| | |
|------|-------------|
| XMIT | Transmit |
| XMTR | Transmitter |
| XTAL | Crystal |

CHAPTER 1

INTRODUCTION

1.1 Telemetry Applications Handbook

The Telemetry Applications Handbook is a book of practical application guidelines, which provide information leading to improvement in overall telemetry system performance and compatibility. The content has been prepared under the direction of the Telemetry Group (TG) of the Range Commanders Council (RCC) to fill the gap between telemetry theory and application. The handbook has been designed for use by telemetry system planners, designers, and operators. The handbook is published as a companion to RCC Document 106, Telemetry Standards, and RCC Document 118, Test Methods for Telemetry Systems and Subsystems.

The information follows the order of signal flow through a telemetry system; that is, the discussions begin at the origin of the source signals and proceed through the system to the receiving subsystem output, where the source signals are recovered. The discussions in each of the following chapters provide information on system design, problem prevention, problem recognition (existing and potential), problem isolation techniques, determination of the origin of problems, and approaches for finding solutions to problems. The guidance provided herein will assist in identifying important systems characteristics and in establishing effective preventive maintenance procedures. Support to each of the topics discussed is provided through the liberal use of signal and system illustrations, graphs, and photographs.

The guidelines contained in this document are addressed as follows:

- Chapter [2](#): Telemetry Signals and Noise
- Chapter [3](#): Telemetry Transmitting System Characterization
- Chapter [4](#): Telemetry Receiving System Characterization

Chapter [2](#), “Telemetry Signals and Noise”, includes discussions on data quality, baseband and radio frequency (RF) spectrums, and bandwidth requirements for the transmission and reception of source signals. The most desirable conditions exist when the source signals are processed through the telemetry system with little or no degradation. However, in practice this condition is seldom achieved because many factors in the telemetry link may cause changes in the source signals, thereby resulting in reduced data quality. A few of the major factors contributing to degradation of data quality include noise, excessive filtering, improper deviation, system nonlinearities, and improper choice of modulation format or code. Careful attention to telemetry system design is the most effective means for minimizing degradation of source signal quality.

The discussion of baseband and RF signals is concerned with the design considerations that must be given to these signals within the telemetry system. Baseband refers to the band of frequencies occupied by the information signals before they are used to modulate the RF carrier. The usual distinction made between the baseband and RF signal frequencies is that the baseband signals range over significantly lower frequencies than the RF signals. The detailed discussions include considerations of the effects introduced by deviation of the carrier signals, effects

because of filtering the conditioned information signals, and bandwidths required to process these signals correctly.

Bandwidth requirements are a major concern in maintaining the quality of the telemetry data. The information presented includes the effects of over use and under use of system bandwidths. Also presented are considerations for selection of system bandwidths for the optimum transmission/reception of telemetry data and any available tradeoffs.

The subsection on link analysis (paragraph [2.10](#)) addresses a number of diverse topics including antenna properties, propagation loss, channel effects, noise figure, signal diversity characteristics, and relay systems. It is obvious that this list of topics includes controllable and non-controllable performance characteristics. Controllable system characteristics, including those of the transmitting and receiving antennas and relay systems, are discussed in terms of performance requirements needed to optimize the transmission and reception of data. Non-controllable items are discussed in terms of the effects they may produce in the received data. Relay systems are included here because the placement of such a system is of necessity between the transmission and reception antennas. The material presented throughout Chapter 2 concerns signal quality, quantity, and through necessity, some methodology.

Chapter [3](#), “Telemetry Transmitting System Characterization”, emphasizes the selection of those parameters necessary to assemble a telemetry system, through the transmitting subsystem. After discussing the signal and bandwidth requirements, it is essential to consider what is required in interfacing signals with the conditioning and transmitting portions of the system. The discussion focuses on the requirements placed upon system elements including transducers, signal conditioning, signal sampling and digitizing, data multiplexing, data formatting and coding, premodulation filtering, RF modulation and antennas, and the appropriate methods of interfacing signals and systems. The information presented starts at the origin of the measured quantity and carries on through the antenna of the transmitting system.

Chapter [4](#), “Telemetry Receiving System Characterization”, discusses the signal path from the receiving antenna, through the entire receiving process, and ending prior to data display. System front-end characteristic discussions include the gain and beamwidth of the receiving antenna and the noise figure, gain, and linearity characteristics of the preamplifiers and multicouplers. Continuing on through the system, information is provided with respect to bandwidth requirements, recording methods such as postdetection and pre-detection, and the measurement of system signal quality using bit error rate (BER) and noise power ratio (NPR) testing techniques. After the received signal has been processed through the entire receiving system with minimum signal degradation, consideration must be given to the type of processed signal analysis and/or the storage media. During real-time data processing, signals are displayed for immediate observation and analysis; in post flight (non-real-time) processing, the signals are stored and reviewed later. The process of storing and recovering the data has been and continues to be a subject of major concern to range operations.

Traditionally, range data has been stored on magnetic tape and was recorded and reproduced using a magnetic tape recorder/reproducer. A more recent trend is to store data either on hard disks or in solid-state memory. These methods are not discussed in this version of the handbook. The emphasis of these discussions is on the characteristics of the recorder/reproducer system and its maintenance and operation. Other discussions will include recording modes, system speed controls, system adjustments, performance tests to determine quality of operation, optimum crossplay methods, and important magnetic tape characteristics.

It is important that the system designer consider proper recovery of the original signal, whether or not the output of the receiver system is processed in real-time or post-flight time. The remainder of the discussion in this chapter will relate the methods and characteristics of demodulation and synchronization used in the recovery of the source signals.

1.2 Telemetry Systems

The field of telemetry developed from the need to transmit information from one location to another, primarily because of the inability to monitor the signal source directly. The primary objective of telemetry is to transmit accurate information between distant or remote locations.

The following discussion provides a broad overview of telemetry systems and includes information on the structure of telemetry systems. The system functions and the design decisions of the telemetry engineer/technician are emphasized.

The reference point for discussion is the definition of a telemetry system. A telemetry system, also known as a telemetering system, is an electrical/electronic system used for measuring a source quantity and transmitting the measured source quantity to a distant receiving station where the source measurements can be displayed and/or recorded. Data analysis is considered a separate topic and, therefore, is not included as part of this handbook.

In general, a telemetry (telemetering) system can be divided into two major functional subsystems (see Figure [1-1](#) and Figure [1-2](#)). The transmitting subsystem includes a source section (transducers), a source-signal processing section (including signal conditioning and multiplexing), and a transmitting section. The receiving subsystem includes major components such as receiving antennas, preamplifiers, receivers, magnetic recorders, demodulators, data synchronizers, and data processors and displays. Since each of these components can significantly affect the quality of the information to be recovered at the receiving subsystem output, the functions and signal characteristics of each component should be clearly defined. Therefore, a detailed understanding of each component's performance characteristics is critical to ensuring that quality is maintained as the information passes through all stages of the telemetry system. The functional role of each component is briefly discussed in the following discussion, and details of performance characteristics will be discussed in subsequent chapters of this handbook.

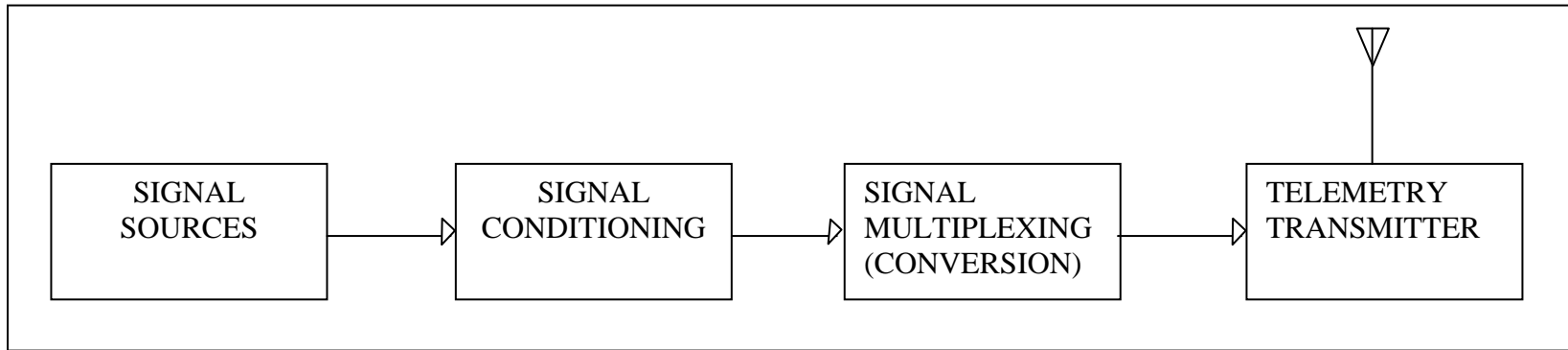

Figure 1-1. Telemetry transmitting system.

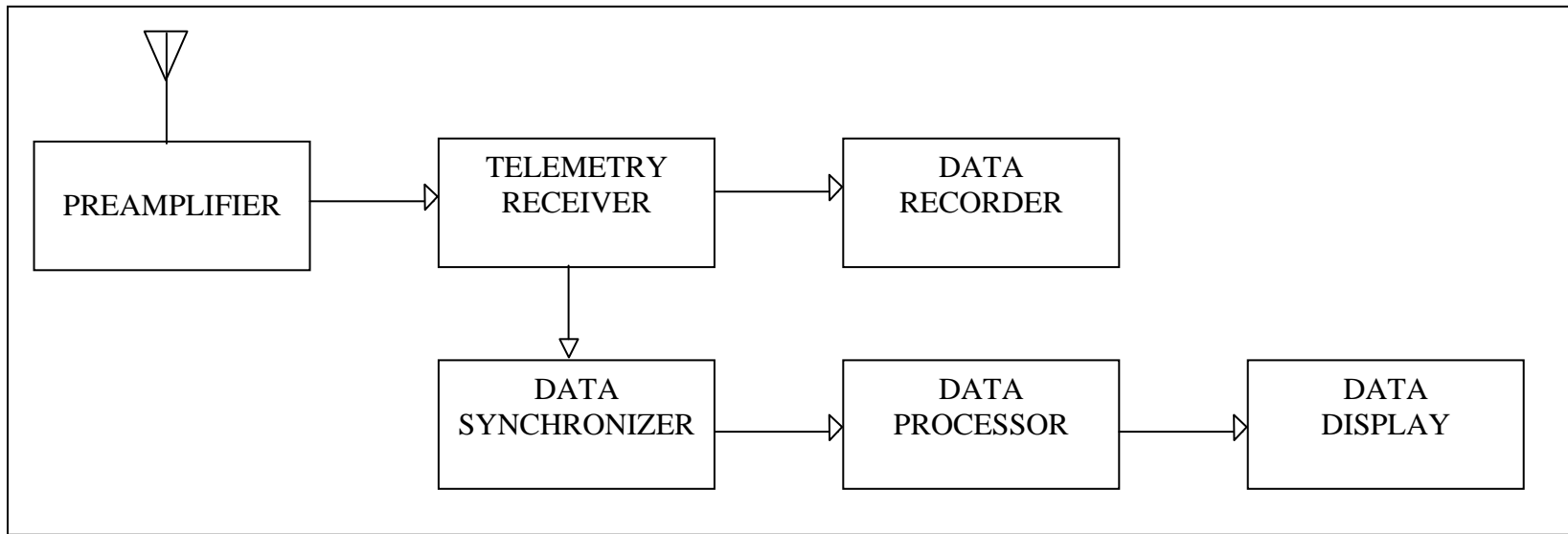

Figure 1-2. Telemetry receiving system.

1-4

The telemetry source information originates as a signal that is to be measured or monitored. The signal can be in many forms, such as electrical, mechanical, thermal, and acoustical. Since the telemetry system is designed to process electrical signals, it is necessary to transform non-electrical signals using a transformation or conversion device known as a transducer. A transducer is defined as "a device by means of which energy may flow from one or more transmission systems to one or more other transmission systems." For example, the non-electrical energy of a vibration on a metallic surface can be converted using a mechanical-to-electrical transducer whose output is an electrical signal that becomes the input to the signal conditioning subsystem. Very simply stated, a transducer is an energy form converter. Since the design and application of transducers is beyond the scope of this discussion, it is sufficient to state that the input signal to a telemetry system is derived from a transducer that is incorporated to transform the signal to be monitored into an electrical signal. The output signals of transducers, although electrical in nature, may exhibit a wide range of signal characteristics in amplitude, frequency, and phase. These signals must be properly interfaced to the subsequent sections of the telemetry system. Interface conditioning (signal conditioning) of the signals is normally done in the signal processing section of the telemetering system. Signal conditioning, in the broad sense, implies a wide range of conditioning techniques from relatively simple to extremely complex, depending on the particular telemetry system requirement and application. The principal objective of signal conditioning is to provide control of signal characteristics (amplitude, offset, and frequency) for correct interface and compatibility with follow-on circuitry and ensure (to the greatest extent possible) that the integrity and quality of the source signal is maintained through the transmission and reception process. The most general type of signal conditioning involves the conversion of signal amplitude (gain and offset), frequency, and phase, to signals that will interface with follow-on circuitry in the telemetry system. This conversion may be as simple as providing a resistive voltage divider network to establish the signal offset, amplitude, and impedance match to subsequent stages in the circuitry of the system. Most signal conditioners consist of resistors, capacitors, and operational amplifiers. However, special applications sometimes require the use of more complex conditioning techniques. Signal conditioning techniques employed to meet these more complex applications include special filtering techniques to limit the spectral components in the signals to be processed. These techniques include:

- a. Phase, frequency, or amplitude detection
- b. Digital-to-analog conversion
- c. Nonlinear processing

The discussion up to this point implies that a telemetry system is used to transmit only a single signal. This implication is far from reality because a telemetry system often has the task to transmit many different signals through a single channel or RF link. To accomplish this task, signal multiplexing is incorporated in the signal processing section of the telemetry system. Generally, signal multiplexing either takes the form of frequency-division multiplexing (FDM) or the form of time-division multiplexing (TDM). With FDM, two or more source signals are transmitted over a single channel by dividing the available baseband frequency space into several non-overlapping channels. The source signals are used to frequency modulate subcarrier oscillators (SCOs) whose output frequencies are contained within the baseband channel. The terms subcarrier oscillator and voltage-controlled oscillator (VCO) are sometimes used

interchangeably. The signals are recovered by using frequency discriminators. Time-division multiplexing is a method for transmitting two or more signals over a common channel by dividing the channel into time intervals so that the source signals may be sampled and time-sequence-multiplexed to form a composite signal train. Signals are recovered by a demultiplexer that sorts out the time spaces so that the original sampled signals may be reassembled.

At this point in the process, a short review could be helpful. The source information, either a single signal or many signals, has been produced by one or more transducers or other information source. The signal(s) have been conditioned in the signal conditioning network to meet interface requirements and may have been modified through analog-to-digital (A/D) or digital-to-analog (D/A) conversions and combined using FDM and/or TDM techniques. The resulting multiplexed signal is much more complex than the output from any of the individual sources. This complex signal, representing the information from all the transducers, must now be transmitted to the receiving section of the telemetering system.

The transmitting section must be carefully designed because it provides the functions to modulate the RF carrier signal, to amplify the modulated carrier signal, to interface the transmitter output to the transmitting antenna, and to direct the transmitted RF signal in the desired direction. In order to simplify the introductory discussion of a telemetry system, the transmitter and transmitting antenna will be considered as a single section. The purpose of this section is to provide the means by which the composite information signal may be sent to the receiving location for detection and processing.

Some key factors in the design of the transmitting section include RF signal stability requirements, RF carrier modulation (deviation) requirements, transmission bandwidth requirements and restrictions, the modulation type employed, RF signal power requirements and transmitting antenna pattern and polarization. These factors directly influence the receiving section performance characteristics required to accurately receive and demodulate the transmitted signal. Therefore, designing an optimum system should include evaluation of the characteristics of both the receiving and transmitting systems so that full compatibility is achieved.

The RF carrier deviation, the baseband bandwidth, and the modulation technique determine the RF bandwidth of the transmitted signal. The RF bandwidth is important to the conservation of spectrum space and to the processing functions of the receiving system. The receiving system must be properly configured to accept and process the received signal, and to minimize degradation because of the filtering and noise effects.

The design of the receiving system must be compatible with the modulation technique employed in the transmitter to deviate the RF carrier signal. Typical modulation methods include frequency modulation (FM) and phase modulation (PM) techniques. Equally important to the transmission/reception process are the power of transmitted RF, the gain of the transmitting and receiving antennas, and the noise temperature of the receiving system. Power and gain are very important factors in determining the signal-to-noise ratio of the signal to be processed by the receiving system. The polarization of the receiving antenna must be

compatible with that of the transmitting antenna for optimum transfer of energy between the two antenna systems and provide for the least amount of RF signal loss and subsequent degradation of the signal-to-noise ratio.

The final step involved in successful recovery of the original source information signals depends on the characteristics of the receiving section. For the purpose of these discussions, the receiving section will include receiving antenna(s), telemetry receiver(s), demodulator(s), magnetic tape recorder(s), and other necessary equipment.

This page intentionally left blank.



CHAPTER 2

TELEMETRY SIGNALS AND NOISE

2.1 Overview

This chapter discusses the characteristics of various telemetry signals. The topics addressed include the following:

- a. Data quality
- b. Premodulation filtering
- c. Transmitter and subcarrier oscillator deviation
- d. Receiver filter selection
- e. Baseband spectral characteristics
- f. Radio frequency spectral characteristics
- g. Link analysis
- h. Frequency modulation demodulator noise characteristics

Both time division multiplex (TDM) and frequency division multiplex (FDM) signals are discussed in this chapter. TDM systems use different time slots to send different signals. Pulse code modulation (PCM) and pulse amplitude modulation (PAM) are examples of TDM systems. The FDM systems use different frequency slots to send different signals at the same time. Frequency modulation/frequency modulation (FM/FM), where several subcarrier oscillators are modulated by different information signals, is an example of an FDM system. Hybrid systems use both TDM and FDM in the same system. An example of a hybrid system is a PCM signal on the baseband with several higher frequency subcarrier oscillators (SCOs).

This chapter includes information on PCM signals using both frequency and phase modulation and both non-return-to-zero (NRZ) and biphase (Manchester) codes. Since PCM is used in most new telemeters, brief summaries of PCM characteristics are included in this chapter. Summaries can be viewed by using the following hyperlinks.

- a. [NRZ PCM/FM](#)
- b. [Biphase PCM/FM](#)
- c. [NRZ PCM/PM](#)
- d. [Biphase PCM/PM](#)
- e. [FQPSK and SOQPSK](#)
- f. [ARTM CPM](#)

Information is also presented on NRZ-PAM/FM signals and the use of noise power ratio (NPR) to simulate FM/FM signals.

2.1.1 NRZ PCM/FM Summary.

| | |
|---|--|
| Polarity Insensitive | No (Level Code); Yes (Mark and Space Codes) |
| dc Component | Yes |
| Transitions | Not Guaranteed |
| Optimum Peak Deviation | $0.35 f_B$ |
| Premodulation Filtering | $0.7 f_B$ or Wider |
| ac Coupling | No |
| BER vs. SNR | 11.8 dB IF SNR in Bandwidth Equal to the Bit Rate for 10^{-5} BER (Optimum for single bit detection). 8.3 dB IF SNR in Bandwidth Equal to the Bit Rate for 10^{-5} BER (Optimum for trellis multiple bit detection). |
| Bit Errors Determined by | Pop Noise |
| Receiver IF Bandwidth | Bit Rate Plus |
| Receiver Video Bandwidth | Bit Rate/2 to Bit Rate |
| Preferred Bit Detector | Filter and Sample |
| Predetection Recording | Recommended |
| Postdetection Recording | Randomization or BIφ Recommended |
| Loop Bandwidth | N/A |
| Demodulator Output Polarity Known | Yes |
| RF Bandwidth for 99 Percent Power | $1.16 X$ Bit Rate (Premodulation Filter = $0.7 f_B$) |
| Maximum Bit Rate in 2 MHz -60 dBc Bandwidth With 30 kHz RBW | 730 kb/s (Premodulation Filter = $0.7 f_B$), Where f_B is Equal to the Bit Rate Frequency. |

2.1.2 Biphase PCM/FM Summary.

| | |
|---|--|
| Polarity Insensitive | No (Level Code); Yes (Mark and Space Codes) |
| dc Component | None |
| Transitions | At Least One Every Bit Period |
| Optimum Peak Deviation | $0.65 f_B$ |
| Premodulation Filtering | $1.4 f_B$ or Wider |
| ac Coupling | Yes |
| BER vs. SNR | 14.8 dB IF SNR in Bandwidth Equal to the Bit Rate for 10^{-5} BER (Optimum) |
| Bit Errors Determined by | Pop Noise |
| Receiver IF Bandwidth | Two X Bit Rate or Wider |
| Receiver Video Bandwidth | Bit Rate to 2 X Bit Rate |
| Preferred Bit Detector | Usually No Choice |
| Predetection Recording | Recommended |
| Postdetection Recording | BI ϕ Recommended |
| Loop Bandwidth | N/A |
| Demodulator Output Polarity Known | Yes |
| RF Bandwidth for 99 Percent Power | 2 X Bit Rate (Premodulation Filter = $1.4 f_B$) |
| Maximum Bit Rate in 2 MHz -60 dBc Bandwidth With 30 kHz RBW | 333 kb/s (Premodulation Filter = $1.4 f_B$) Where f_B is Equal to the Bit Rate Frequency. |

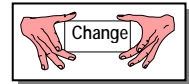
2.1.3 NRZ PCM/PM Summary.

| | |
|---|--|
| Polarity Insensitive | No (Level Code); Yes (Mark and Space Codes) |
| dc Component | Yes |
| Transitions | Not Guaranteed |
| Optimum Peak Deviation | 90° |
| Premodulation Filtering | 1.0 f_B or Wider |
| ac Coupling | No |
| BER vs. SNR | 10.7 dB IF SNR in Bandwidth Equal to Bit Rate for 10^{-5} BER (Optimum with Mark or Space Codes) |
| Bit Errors Determined by | Additive White Gaussian Noise |
| Receiver IF Bandwidth | As Wide as Possible Without Interference |
| Receiver Video Bandwidth | Bit Rate or Wider |
| Preferred Bit Detector | I/D if Filters are Wider than $0.7 f_B$ |
| Predetection Recording | Recommended |
| Postdetection Recording | Randomization or BI ϕ Recommended |
| Loop Bandwidth | Less than $0.05 f_B$ |
| Demodulator Output Polarity Known | No |
| RF Bandwidth for 99 Percent Power | 4 X Bit Rate (Premodulation Filter = $1.0 f_B$) |
| Maximum Bit Rate in 2 MHz -60 dBc Bandwidth with 30 kHz RBW | 333 kb/s (Premodulation Filter = $1.0 f_B$) Where f_B is Equal to the Bit Rate Frequency. |

2.1.4 Biphase PCM/PM Summary.

| | |
|---|---|
| Polarity Insensitive | No (Level Code); Yes (Mark and Space Codes) |
| dc Component | None |
| Transitions | At Least One Every Bit Period |
| Optimum Peak Deviation | 90° (Mark and Space Codes); 75° (Level Code) |
| Premodulation Filtering | 2.0 f_B or Wider |
| ac Coupling | Yes |
| BER vs. SNR | 11.0 dB IF SNR in Bandwidth Equal to Bit Rate for 10^{-5} BER (Optimum with Mark or Space Codes) |
| Bit Errors Determined by | Additive White Gaussian Noise |
| Receiver IF Bandwidth | As Wide as Possible Without Interference |
| Receiver Video Bandwidth | 2 X Bit Rate or Wider |
| Preferred Bit Detector | Usually No Choice |
| Predetection Recording | Recommended |
| Postdetection Recording | BI ϕ Recommended |
| Loop Bandwidth | Less than: 0.05 f_B (90°); 0.02 f_B (75°) |
| Demodulator Output Polarity Known | No (PSK Demod); Yes (PM Demod) |
| RF Bandwidth for 99 Percent Power | 8 X Bit Rate (90°); 6 X Bit Rate (75°) (Premodulation Filter = 2.0 f_B) |
| Maximum Bit Rate in 2 MHz -60 dBc Bandwidth with 30 kHz RBW | 125 kb/s (90°) to 166 kb/s (75°) (Premodulation Filter = 2.0 f_B) Where f_B is Equal to the Bit Rate Frequency. |

2.1.5 FQPSK and SOQPSK Summary.

| | |
|---|--|
| Polarity Insensitive | No |
| dc Component | No (Randomization required) |
| Transitions | Guaranteed |
| BER vs. SNR | 11.8 dB IF SNR in Bandwidth Equal to Bit Rate for 10^{-5} BER |
| Bit Errors Determined by | Additive White Gaussian Noise |
| Receiver IF Bandwidth | Bit rate or wider |
| Predetection Recording | Optional |
| Postdetection Recording | Digital recording |
| Demodulator Output Polarity Known | Yes |
| RF Bandwidth for 99 Percent Power | 0.78 X Bit Rate |
| Maximum Bit Rate in 2 MHz -60 dBc Bandwidth with 30 kHz RBW | 1300 kb/s |

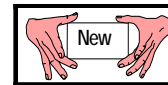
2.1.6 ARTM CPM Summary.

| | |
|---|---|
| Polarity Insensitive | No |
| dc Component | No (randomization required) |
| Transitions | Guaranteed |
| ac Coupling | No |
| BER vs. SNR | 12.8 dB IF SNR in Bandwidth Equal to Bit Rate for 10^{-5} BER |
| Bit Errors Determined by | Additive White Gaussian Noise |
| Receiver IF Bandwidth | Bit rate or wider |
| Predetection Recording | Not Recommended |
| Postdetection Recording | Digital Recording |
| Demodulator Output Polarity Known | Yes |
| RF Bandwidth for 99 Percent Power | 0.56 X Bit Rate |
| Maximum Bit Rate in 2 MHz -60 dBc Bandwidth with 30 kHz RBW | 1700 kb/s |

2.2 Non-Return-To-Zero Pulse Code Modulation/Frequency Modulation (NRZ PCM/FM)

2.2.1 **Introduction.** The NRZ PCM/FM is a concatenated coding and modulation method used to send digital data over a transmission link. The method provides a shift in carrier frequency of “x” hertz (Hz) higher in frequency to represent one state of a binary signal (usually the ONE state) and a shift of x hertz lower in frequency to represent the other state (usually the ZERO state) of the binary signal. The most commonly used code for PCM/FM is the non-return-to-zero level (NRZ-L) code Reference [2a](#)). As the name implies, the level of the NRZ-L modulation stays the same until the data changes state; that is, the level does not go to zero level between the data pulses.

The non-return-to-zero mark (NRZ-M) and the non-return-to-zero space (NRZ-S) versions are sometimes used when very long strings of either ones or zeros are expected in the data stream. These codes are illustrated in the Telemetry Standards, IRIG Standard 106 (reference [2a](#)). If long streams of zeros (but not strings of ones) are expected in the data stream, then the NRZ-S coding method is used because it provides a transition for each zero in the data stream. The NRZ-M code is used to force transitions in the data stream when long strings of ones are expected in the data. The purpose for selecting a coding method that provides additional transitions is because the PCM bit synchronizer needs the transitions to generate a reconstructed clock containing the proper phase and frequency.

The NRZ-M and NRZ-S codes have the advantage of being polarity insensitive; that is, the PCM bit stream can be inverted, and no change will occur in the output of the PCM bit synchronizer. A disadvantage of using these codes is that every isolated bit error also causes the following bit to be in error. When using an error-correcting code in a system where the mark or space codes are used, the error correction encoding should be done after the data is converted to the mark or space code.

Several other techniques may be used to prevent the problems associated with long strings of ones or zeros in the bit stream, including randomizing the data (usually the preferred method), adding an odd parity bit to words that have an odd number of data bits, and using biphase (Manchester) coding.

The intermediate frequency (IF) signal-to-noise ratio (SNR) in a bandwidth equal to the bit rate for a bit error rate (BER) of 10^{-5} in Figure [2-1](#) is approximately 11.8 dB. The IF SNR value is close to optimum for a single symbol bit detector. Increasing the IF SNR by 1 dB decreases the BER to approximately 10^{-6} . The BER will decrease by at least a factor of 10 for each additional dB the IF SNR is increased. Decreasing the IF SNR by 1.2 dB (to 10.6 dB) increases the BER to approximately 10^{-4} . The BER values will be different if the premodulation or IF filters are different from those in Figure 2-1 or if any extra encoding/decoding is used.

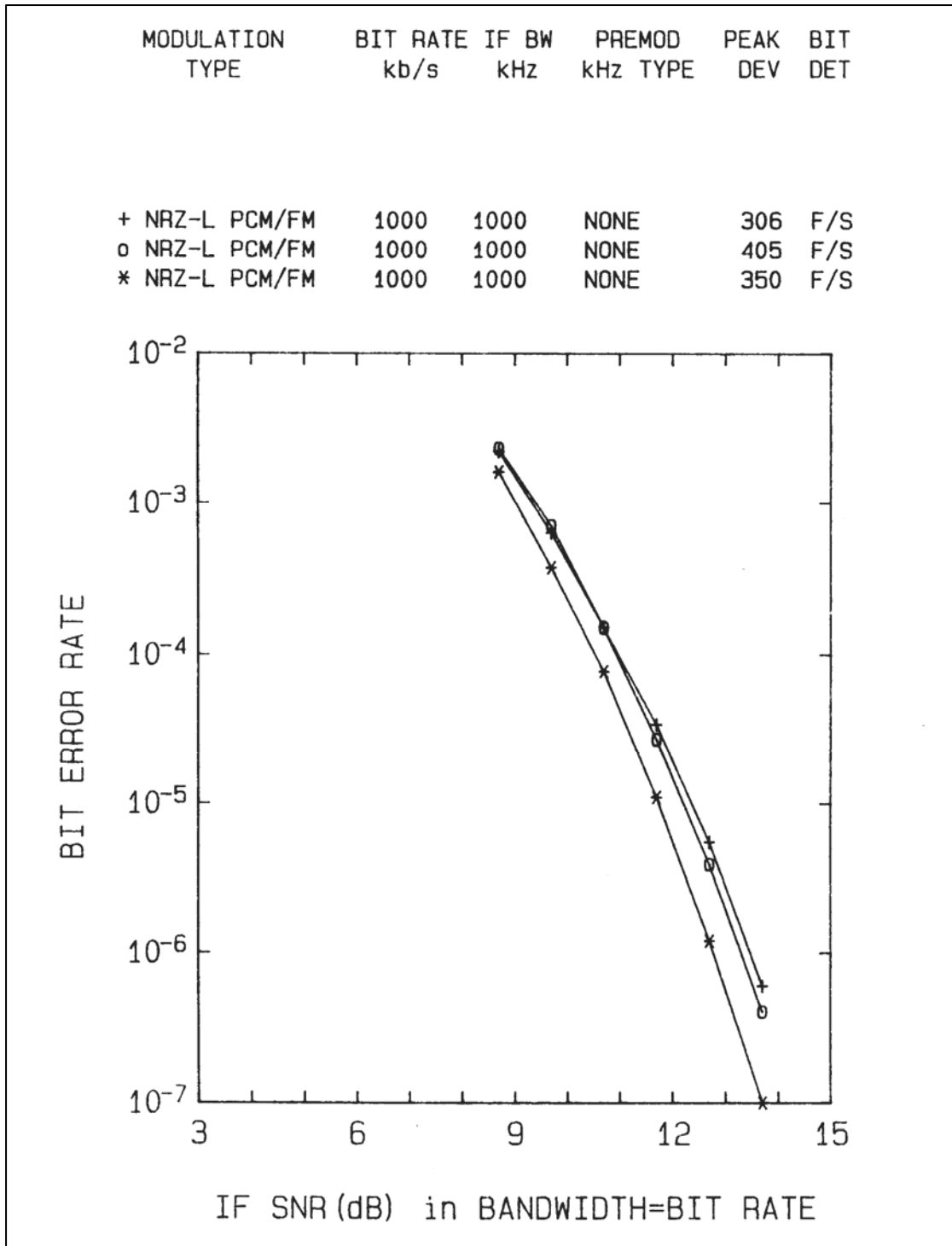

Figure 2-1. NRZ-L PCM/FM BER for three peak deviations.

Figure 2-2 shows that a multi-symbol demodulator (Reference 2b and Reference 2c) can achieve a BER of 10^{-5} at an IF SNR in a bandwidth equal to the bit rate of about 9.5 dB. The peak deviation for Figure 2-2 was 0.35 times the bit rate. The ratio of signal energy per bit to noise power density per Hz (E_b/N_o) is equivalent to IF SNR in a bandwidth equal to the bit rate. The curves labeled R1 through R3 show performance with various receivers and single-symbol detectors. Note that the single-symbol performance is worse than the multi-symbol detector performance by 2.5 dB or more.

The performance of some multi-symbol detectors is degraded if the peak deviation is not within about 5 percent of the optimum value.

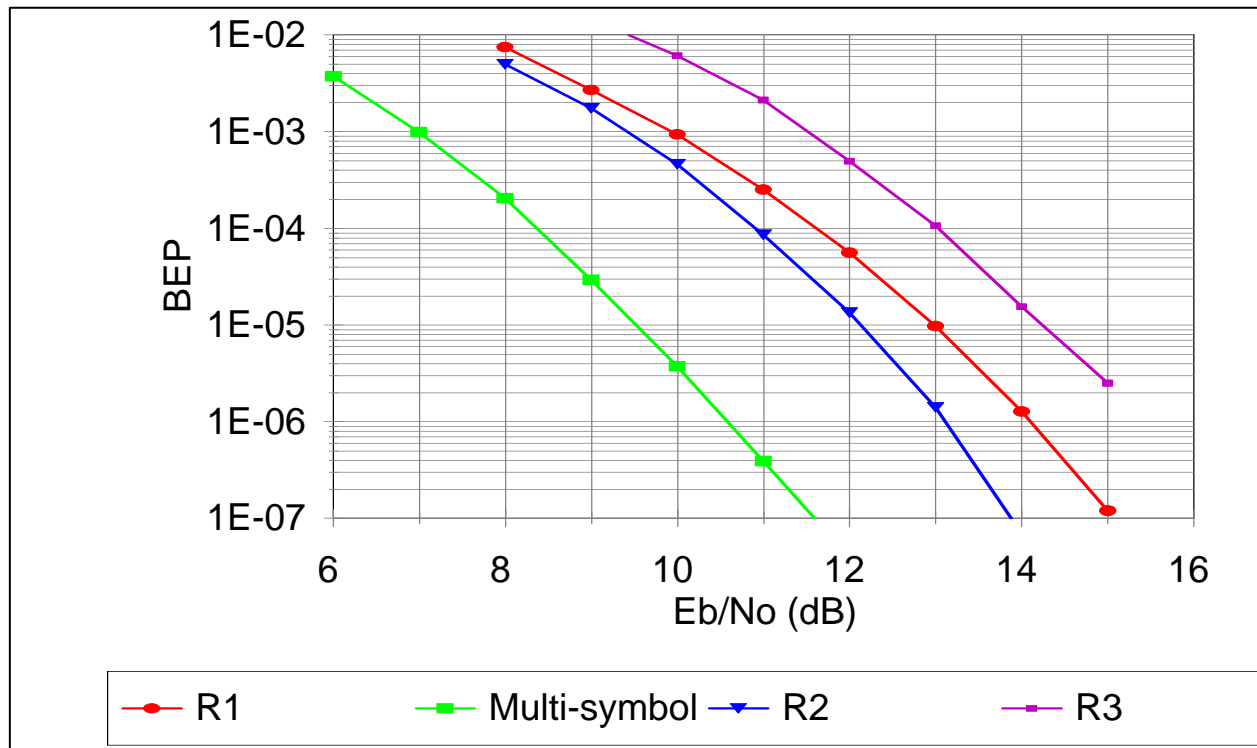

Figure 2-2. BEP versus E_b/N_o for NRZ-L PCM/FM with a peak deviation of 0.35 times the bit rate.

The following sections discuss performance of traditional FM demodulators with single-symbol detectors (unless otherwise noted).

Note: Figure 2-2 shows that a multi-symbol demodulator (Reference 2b and Reference 2c) can achieve a BER of 10^{-5} at an IF SNR in a bandwidth equal to the bit rate of about 9.5 dB (the theoretical value is about 8.3 dB).

2.2.2 Selection of Peak Deviation. The optimum peak deviation for NRZ PCM/FM is approximately 0.35 times the bit rate; that is, a 1.0 megabits per second (Mb/s) bit stream should have a peak deviation of 350 kilohertz (kHz) and a peak-to-peak deviation of 700 kHz (References [2d](#), [2e](#), [2f](#), and [2g](#)). The RF spectra for various peak deviations are presented in paragraph [2.2.8](#). Most papers on the subject of PCM/FM deviation use peak-to-peak values (usually symbolized by an h), but peak deviation is used in this document to keep PCM/FM consistent with FM/FM, PAM/FM, and PCM/PM where peak deviation is generally used to describe the amount of deviation. This optimum value of peak deviation is valid when using IF bandwidths (BWs) that are between 1 and 3 times the bit rate and for systems where the total incidental frequency modulation (IFM) is much smaller than the peak deviation. Incidental Frequency Modulation is defined as the carrier deviation produced by frequency modulation when the modulating signals are not wanted and are internal to the RF signal source. Typical transmitter IFM specifications are 5 kHz peak or 2 kHz rms. Therefore, the minimum PCM/FM peak deviations should be 15 to 20 kHz; that is, the deviations should be 3 to 4 times peak or 7.5 to 10 times rms. The actual minimum usable peak deviation is a function of the actual transmitter frequency stability and the receiving system frequency stability. In addition, phase modulation may be preferable to frequency modulation for low bit rate systems. If the predetection bandwidth is wider than 3 times the bit rate, the optimum peak deviation is approximately 0.35 times the predetection bandwidth (Reference [2h](#)). As an example, assume the need to transmit 64 kb/s (NRZ-L PCM/FM), and the narrowest IF bandwidth of the receiving system is 500 kHz. In addition, assume that predetection recording and demodulation are not options. The IF SNR for a 10^{-5} BER with a 22 kHz peak deviation is approximately 10.3 dB. The IF SNR for a 10^{-5} BER with a peak deviation of 175 kHz is approximately 7.6 dB. However, a better option, if available, would be to use NRZ-M (or NRZ-S) PCM/PM with 90° peak deviation and a PSK demodulator. A 10^{-5} BER could be achieved with an IF SNR of approximately 1.8 dB (IF SNR in bandwidth equal to bit rate of 10.7 dB). Data quality, usually measured by bit error rate (BER) performance, is affected by the amount of carrier deviation and also the premodulation filter bandwidth, predetection filter, demodulator, and bit detector characteristics.

When peak deviation is increased to a value of approximately 0.4 times the bit rate, the BER performance is typically degraded by a few tenths of a dB; that is, at a BER of 1×10^{-5} , the degradation is in a range of 0.2 to 0.4 dB (see Figure [2-1](#)). The major cause of degradation to signal quality is the additional attenuation introduced by the predetection IF filter at the peak deviation value; that is, approximately 0.5 dB more attenuation is present at ± 400 kHz than at ± 350 kHz (see Figure [2-3](#)). The result is that the instantaneous IF SNR is reduced by approximately 0.5 dB, thus producing more bit errors in the data stream because of "pop" noise. Another cause of additional pops (see paragraph [2.12](#)) with higher peak deviation is that the difference in frequency between the instantaneous signal frequency and the instantaneous noise frequency is usually larger. Therefore, the probability of the noise being larger than the signal for a long enough time interval to cause a pop is increased because the required time interval is inversely proportional to the difference in frequency. An additional possible cause of increased BER with increased deviation is that the phase linearity of the IF filter gets worse toward the band edges, which produces more intersymbol interference.

However, the signal energy per bit is increased by 1.2 dB, ($20 \log (0.4/0.35)$) which significantly reduces the number of bit errors because of fluctuation noise (see paragraph [2.12](#)). Therefore, when the premodulation filter bandwidth is set to one-half the bit rate, the degradation, because of slight over deviation, should be negligible. The reason the degradation is negligible is that the narrow premodulation filter bandwidth reduces the amplitude of single bits of either polarity, thus increasing the susceptibility to the effects of fluctuation noise. Hence, with an IF bandwidth equal to the bit rate and a premodulation filter bandwidth equal to one-half the bit rate, fluctuation noise is the major cause of bit errors.

In the case where the peak deviation is decreased to a value corresponding to approximately 0.3 times the bit rate, the bit error performance is typically degraded by approximately 0.6 dB at a BER of 1×10^{-5} (with the predetection IF bandwidth set equal to the data bit rate). The reason for this degradation is that the signal energy per bit is reduced by 1.3 dB, $20 \log (0.3/0.35)$, which has the effect of significantly increasing the number of bit errors because of fluctuation noise. This increase in bit errors more than compensates for the decrease in bit errors resulting from pop noise, because of decreased predetection IF attenuation (approximately 0.4 dB in Figure [2-3](#)).

Decreasing the peak deviation by 3 dB and 6 dB requires an increase in SNR of 2.3 and 5.2 dB at a BER of 10^{-5} (see illustration at Figure [2-4](#)). If conditions are that BER = 10^{-5} , IF BW = 1.4 x bit rate, $\Delta f = 0.35$ times bit rate, and premodulation filter bandwidth = 0.7 times bit rate, then approximately one-third of the errors are due to fluctuation noise and two-thirds are due to pop noise. Increasing the deviation rapidly increases the errors because of pop noise, while decreasing the deviation rapidly increases the errors because of fluctuation noise. A peak deviation of 0.7 times the bit rate degrades the data quality by 4 to 6 dB when the IF bandwidth is equal to the bit rate. The minimum BER is achieved when the peak deviation is 0.35 (-10 percent, +20 percent) of the bit rate for IF bandwidths between 1 and 3 times the bit rate.

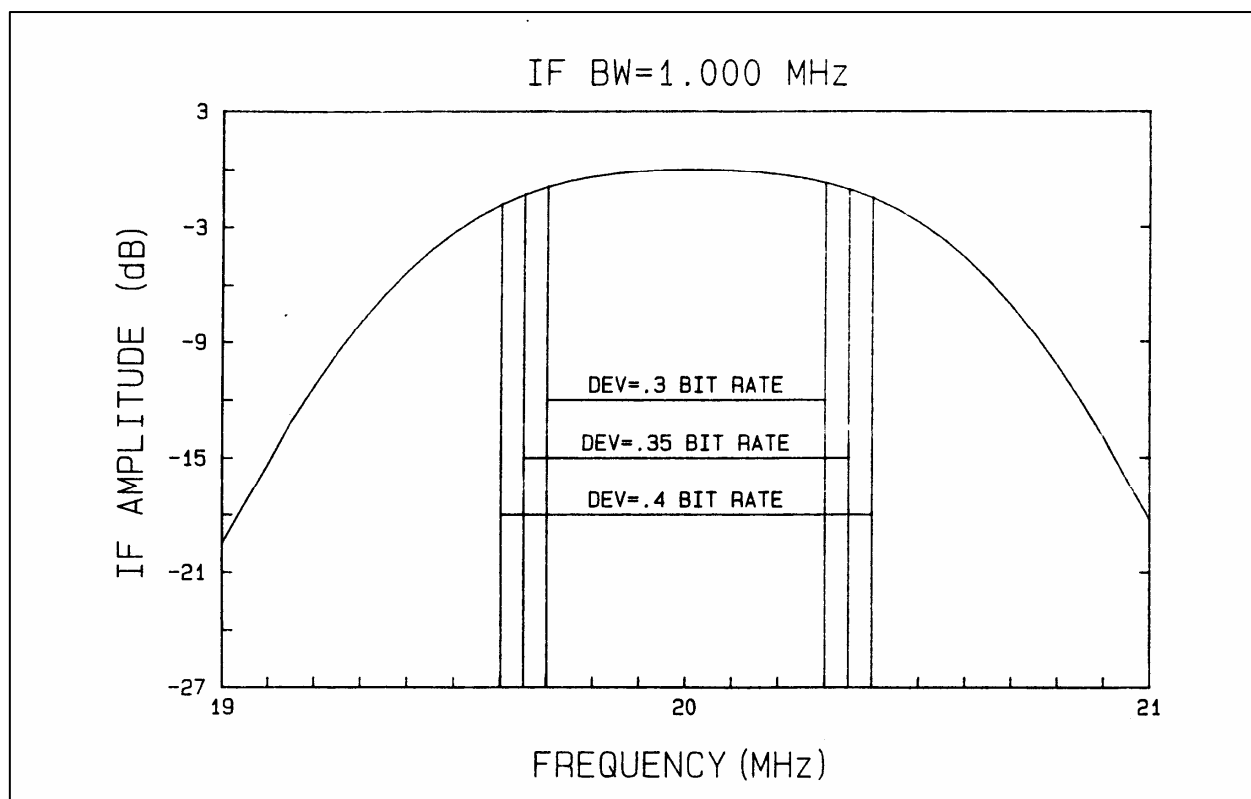

Figure 2-3. IF filter attenuation versus peak deviation.

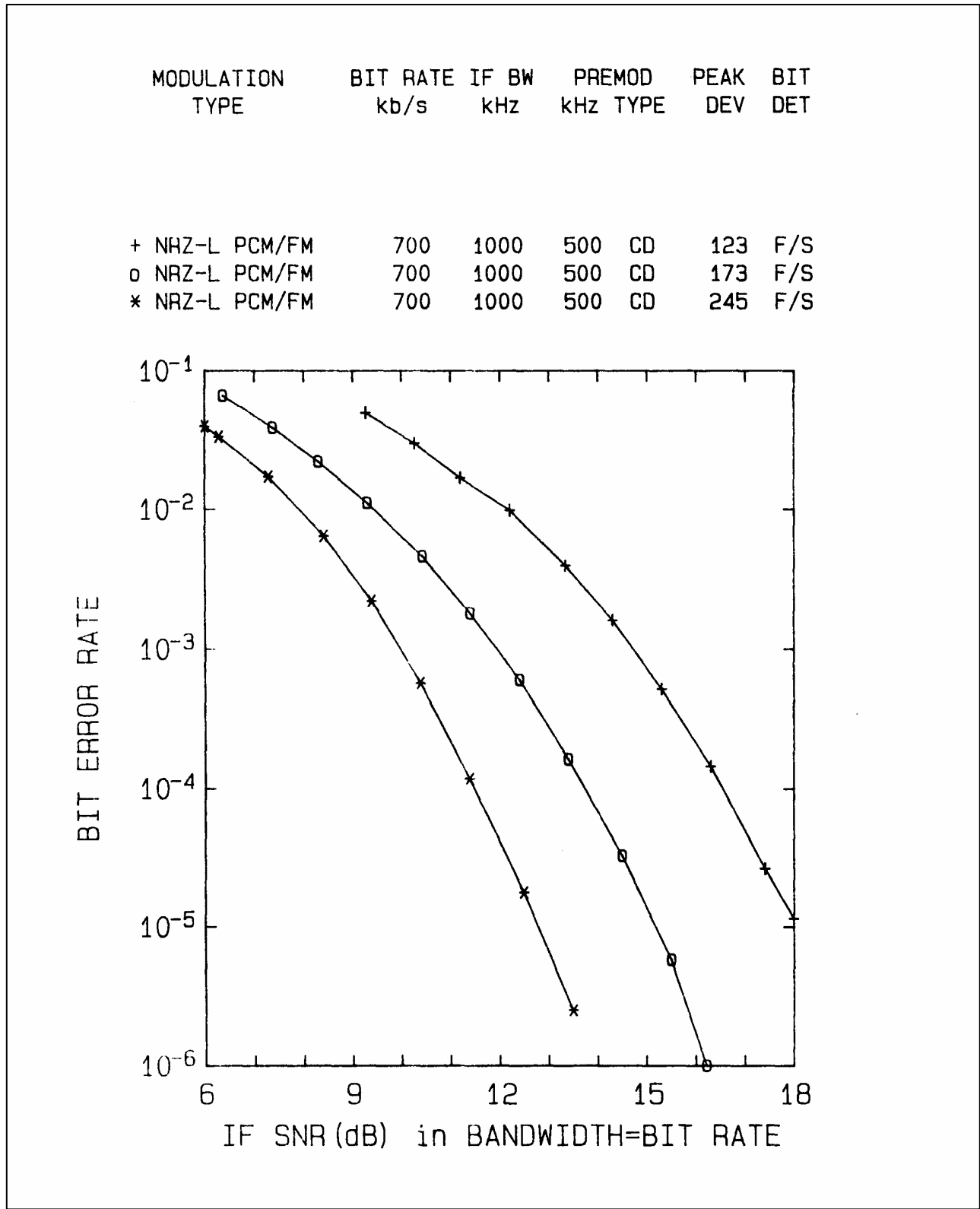

Figure 2-4. BER for peak DEV/bit rate = 0.175, 0.25, and 0.35.

2.2.3 Selection of Premodulation Filter. Premodulation filters are used to reduce the baseband and RF bandwidths of the PCM signal. The best premodulation filter is the widest linear phase filter that allows the spectral occupancy requirements to be met. A low pass filter bandwidth (-3 dB) having a value that is equal to or greater than 0.7 times the bit rate will not cause a significant increase in the bit error rate. However, the use of a premodulation filter bandwidth of 0.5 times the bit rate will degrade the performance by 1 dB when the IF bandwidth is equal to the bit rate. The bit error rates achieved while using linear phase filters were repeatedly as good as or better than the bit error rates achieved while using constant amplitude (CA) filters having the same 3 dB bandwidth. It should be noted that digital transmitters typically include an internal premodulation filter.

Figure 2-5 through Figure 2-8 show the PCM wavetrains that result when an NRZ-L signal is filtered at the bit rate and one-half the bit rate using 5-pole linear phase and constant amplitude (Butterworth) low pass filters.

2.2.4 Direct Current (dc) Component and Alternating Current (ac) Coupling. The level of the dc component contained in an NRZ-L data stream can vary over a wide range from essentially no dc component with randomized data to essentially 100 percent dc, when long strings of data without a transition are encountered. The use of ac coupling eliminates the dc component. The Inter-Range Instrumentation Group (IRIG) Standards prohibit the use of ac coupling of many NRZ-L signals by the statement that "frequency deviation from the carrier shall be the same for each occurrence of the same level." Using ac coupling should be avoided because it forces the average value of the data stream to be 0.0 Vdc. When the number of ones and zeros is nearly equal over any short time interval, the frequency for a one will be f_0+x and the frequency for a zero will be f_0-x . However, if the ratio of ones to zeros changes to three ones to each zero and the signal is ac-coupled, then the frequency for a one will be $f_0+x/2$ and the frequency for a zero will be $f_0-3x/2$. The lack of balance between the ones and zeros can cause major data degradation problems because of the effects of signal attenuation in the final IF filter of the receiver or in any other bandwidth-limited device in the telemetry system. One example could be an analog microwave link because the level that is present least often appears to be deviated farther from the carrier as is illustrated in Figure 2-9. In Figure 2-9, the dc-coupled frequencies for ones and zeros are attenuated by 0.9 dB by the receiver IF filter. Assume the BER is 10^{-5} . Increasing the signal by 0.8 dB decreases the BER to 1.6×10^{-6} and decreasing the signal by 2.8 dB increases the BER to 10^{-3} . Therefore, the BER for the ac-coupled signal would be:

$$3/4 (1.6 \times 10^{-6}) + 1/4 (10^{-3}) = 2.5 \times 10^{-4}$$

The RF power would have to be increased by 1.9 dB to decrease the BER to 10^{-5} . Consequently, the data quality has been degraded by 1.9 dB by ac-coupling the signal. The degradation would be greater if the ratio of ones to zeros (or vice versa) was larger than 3 to 1. An additional problem encountered when using ac coupling is that the energy associated with each bit in a long string of data bits without transitions is less than the energy in the previous bit because the decay is due to the resistance-capacitance (RC) time constant. The NRZ signals should never be ac-coupled unless some sort of positive control exists over the ratio of ones to zeros. The ratio should be one. One method of achieving this control is to randomize the NRZ signal. However,

most randomization techniques cause an increase in the BER. Adding a parity bit does not provide sufficient control.

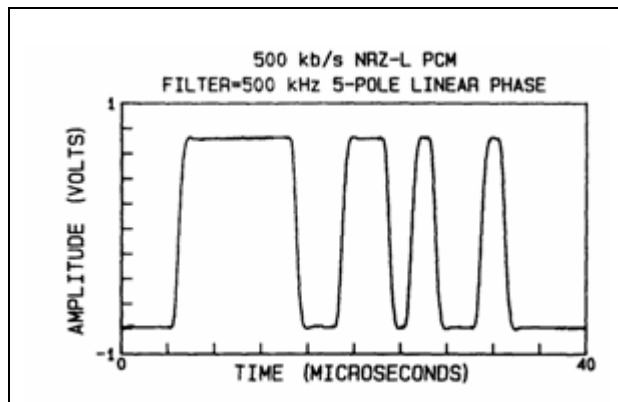

Figure 2-5. NRZ-L signal with PREMOD filter = bit rate.

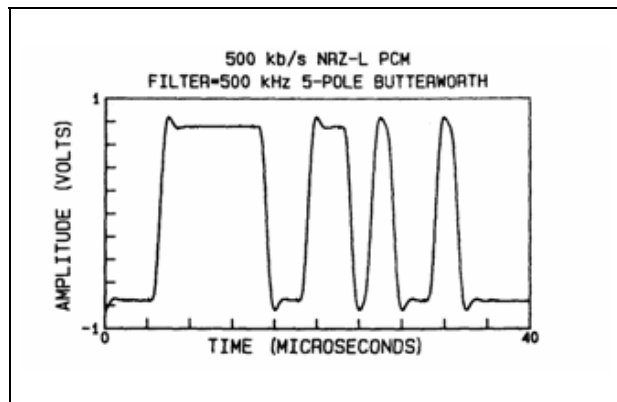

Figure 2-6. NRZ-L signal with PREMOD filter = bit rate (CA).

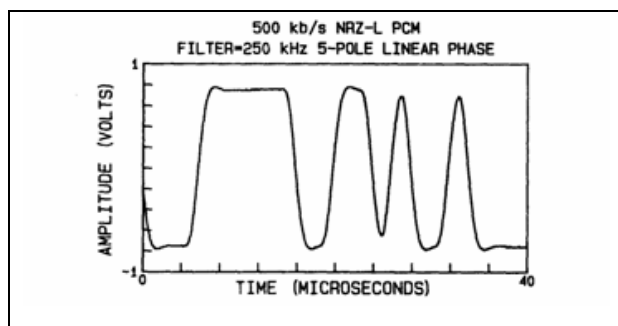

Figure 2-7. NRZ-L signal with PREMOD filter = bit rate/2 (CD).

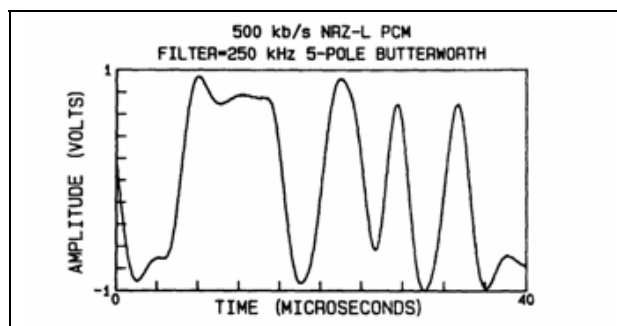

Figure 2-8. NRZ-L signal with PREMOD filter = bit rate/2 (CA).

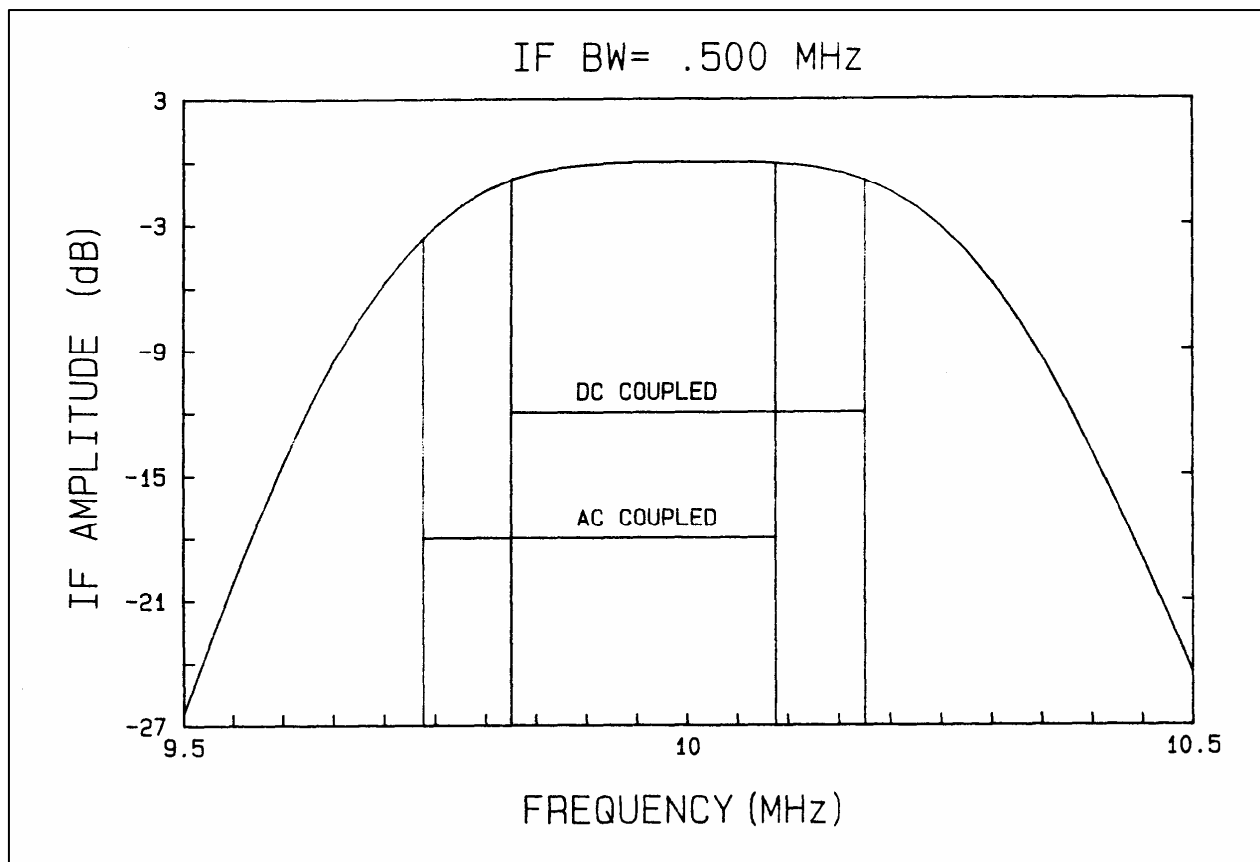

Figure 2-9. Effect of ac coupling on NRZ PCM/FM signal.

2.2.5 Selection of Receiver IF Bandwidth. When using a peak deviation value corresponding to approximately 0.35 times the bit rate, the optimum IF bandwidth is approximately equal to the bit rate when lumped constant IF filters are used and approximately equal to 1.2 times the bit rate when surface acoustic wave (SAW) or fast roll-off digital filters are used. This is illustrated in Figure 2-10 with digital IF filters. The lowest BEPs with a 10 Mb/s NRZ-L PCM/FM signal were achieved with the 12 MHz IF filter bandwidth, with the 15 MHz bandwidth about 0.3 dB worse, and the 10 MHz bandwidth about 0.7 dB worse. It should be noted that when a multi-symbol detector was used there was very little difference in the BEPs with the various receiver filter bandwidths (curves with NOVA in the legend, the NOVA® demodulator included a 12 MHz wide SAW filter). It is further noted that when an IF bandwidth with a value equal to the bit rate is used, the receiver tuning becomes very critical. The effect of improper tuning is illustrated in Figure 2-11 with a receiver with lumped constant filters. Tuning problems can be caused by transmitter or receiver frequency errors, transmitter drift, Doppler shift, receiver drift, and operator errors at the ground station. Small tuning errors can produce relatively large increases in the bit error rate. The reason for the increase in bit error rate is that the slopes of the IF bandpass filter roll off quite rapidly outside of the receiver passband, thereby attenuating the signal when the receiver is detuned. The following example points out the effects of receiver detuning: For a signal at 500 kb/s data rate passing through a 500-kHz IF bandwidth, the penalty is approximately 1 dB for 50 kHz of detuning and 2.5 dB for 100 kHz of detuning. For comparison, the penalty for using a 750-kHz IF bandwidth is approximately 0.7 dB, and the penalty for using a 1.0-MHz IF bandwidth is approximately 1.8 dB. The loss with a 100-kHz detuning error and a 750-kHz IF is approximately 1.0 dB, and the loss with a 1.0-MHz IF is approximately 0.6 dB. The actual losses in a given receiver depend on the amplitude and phase characteristics of receiver filters. Some receiver IF filters have amplitude characteristics that are not symmetrical about the center frequency, causing excessive bit errors in one of the two states of the PCM signal.

A second area of concern associated with using receiver IF bandwidths set equal to the bit rate is that many receiver IF filters provide poor phase performance near their upper and lower band edges. Degraded phase performance can produce intersymbol interference and distorted bit symbol waveforms resulting in an increase in the bit error rate; the increase is more predominant at the lower bit error rates. Signal-to-noise ratio penalties of approximately 1 dB (0.7 to 1.4 dB) are typical at bit error rates of 1×10^{-5} with an IF bandwidth set to a value equal to the bit rate when a linear phase IF filter is not used. The penalty for using a non-linear phase IF filter decreases at higher bit error rates and for IF bandwidths which are set wider than a value equal to the bit rate because the bit error rate is dominated by pop noise under these conditions.

When PCM/FM signals are predetection-recorded, the receiver IF bandwidth should be set wider than the bit rate. The two major reasons for selecting the wider IF bandwidths when using predetection recording techniques are:

- a. The effective filtering includes not only the receiver bandpass filter, but also the predetection downconverter, the magnetic tape recorder/ reproducer, and the predetection filter in the demodulator, and

- b. The selection of the wider IF filter provides the means for recording the signal with a minimum amount of degradation.

It is extremely difficult to recover data that has been degraded through excessive filtering prior to recording on magnetic tape. However, it is relatively simple to filter out excessive out-of-band noise that is recorded on the magnetic tape. Note that the receiver bandwidth should never be wider than approximately two times the predetection carrier frequency. Extremely wide IF bandwidths should not be used because the noise frequency components will fold-over around the zero hertz origin and back into the data frequencies. The result is that, when using extremely wide IF filter bandwidths, a degradation of 3 dB in the SNR could occur.

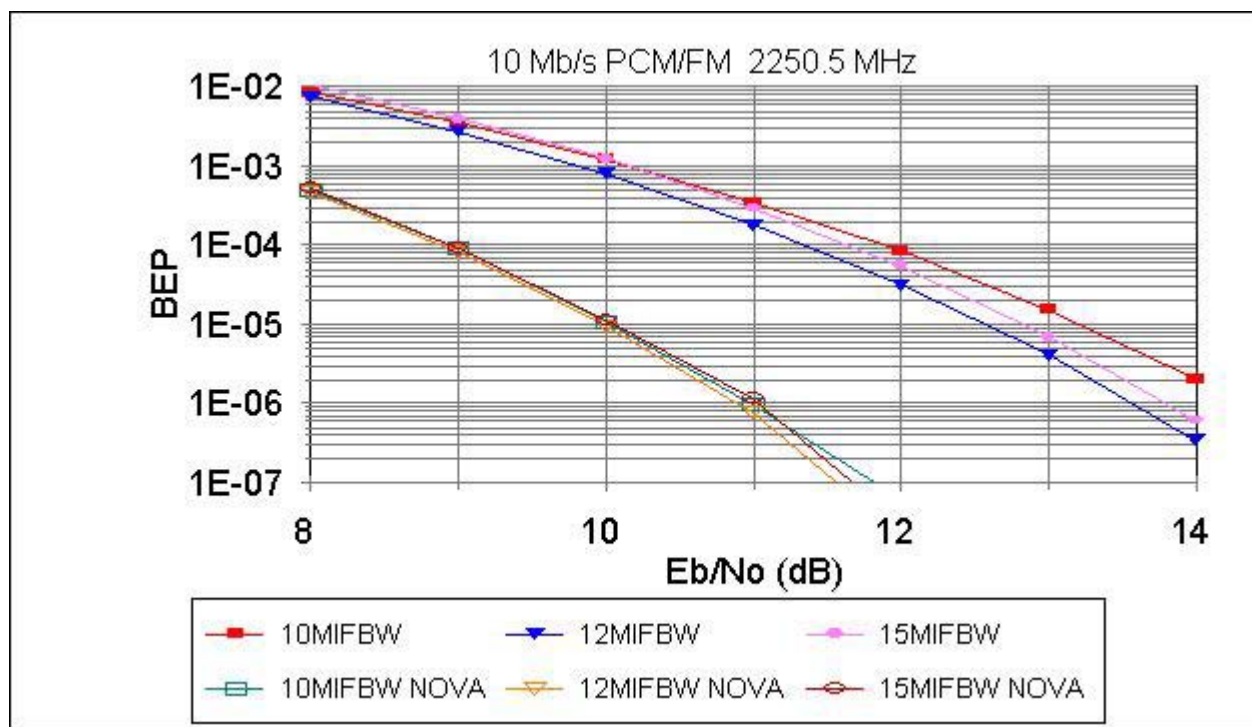

Figure 2-10. BEP for 10 Mb/s PCM/FM with various IF filters.

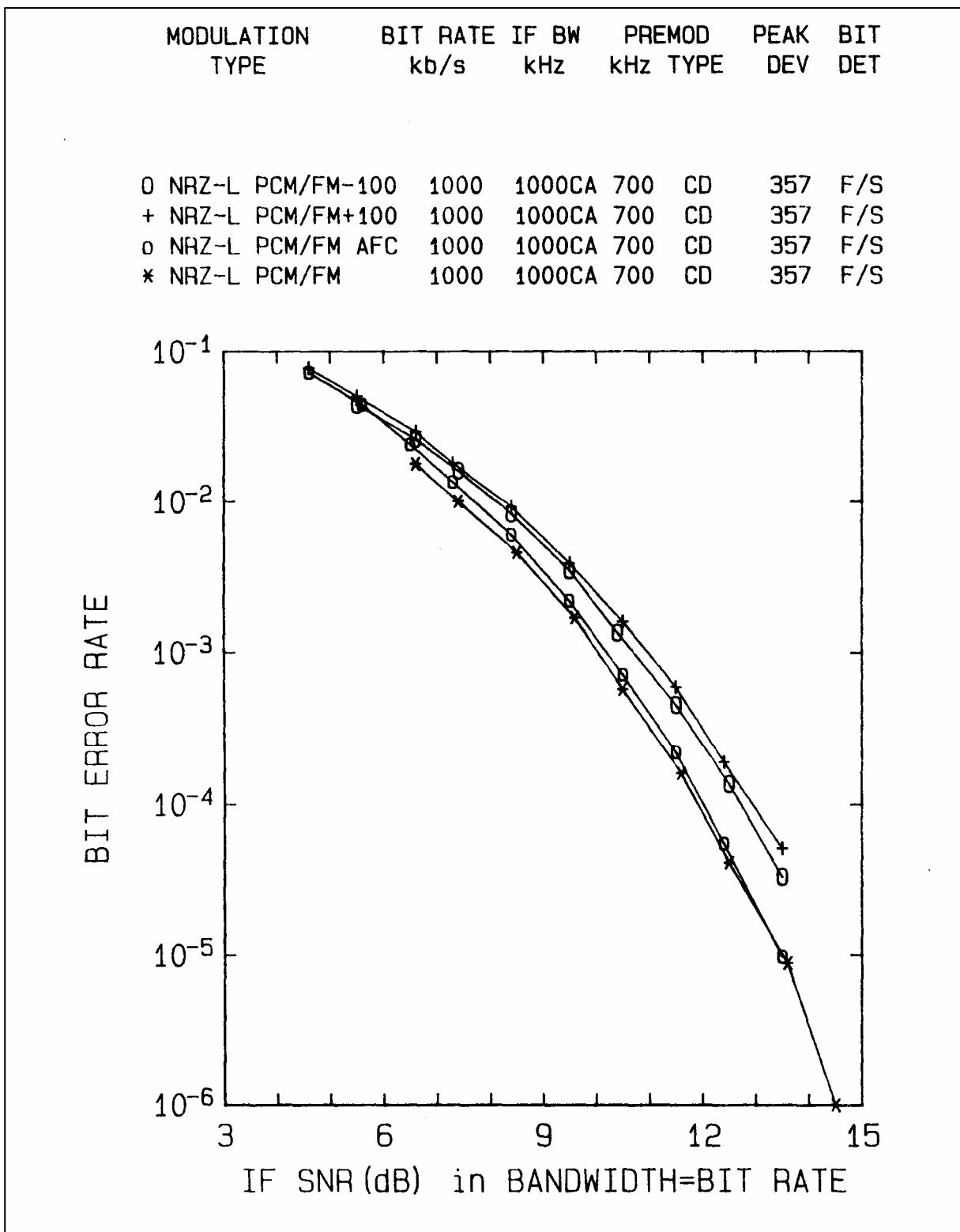
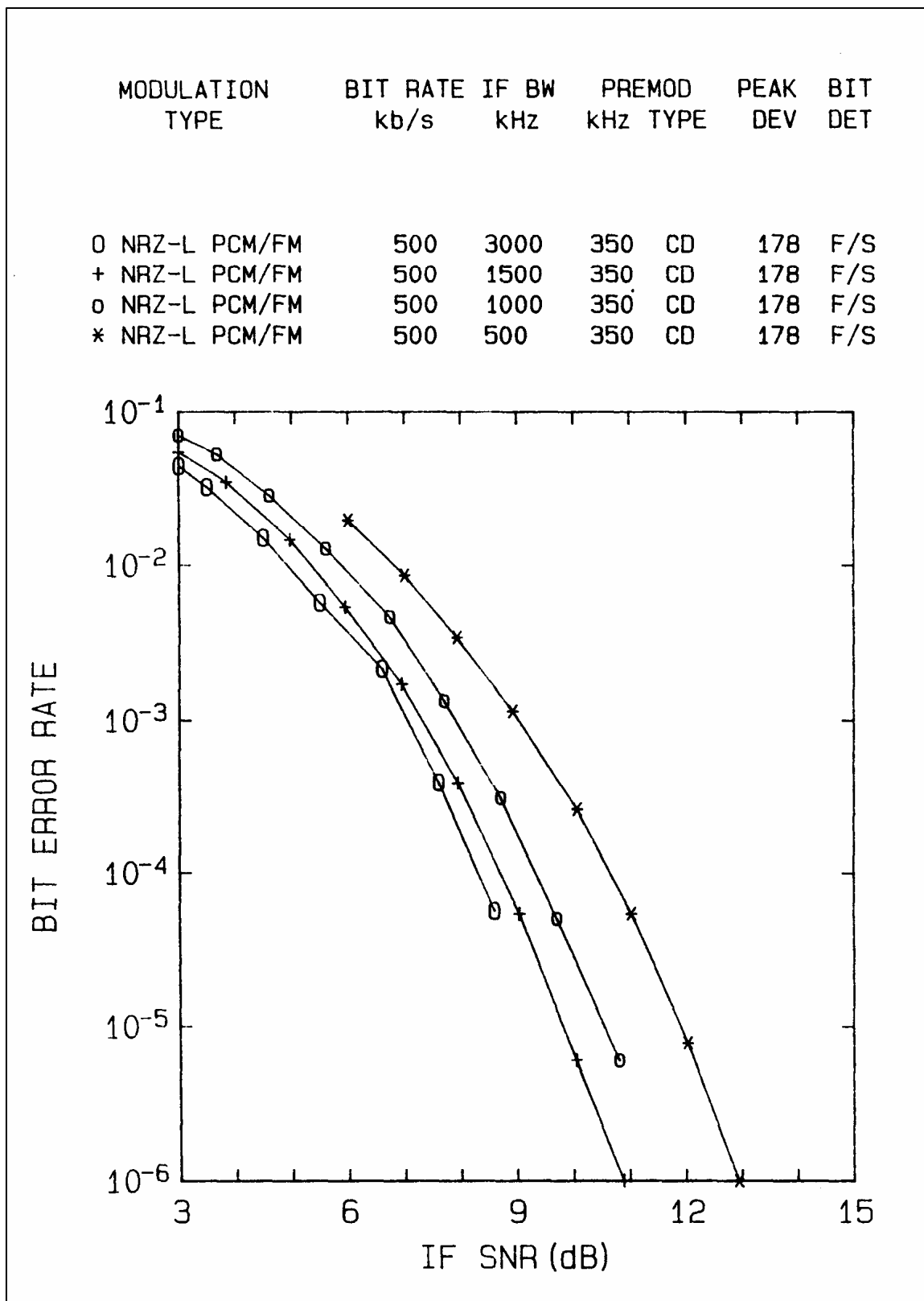

Figure 2-11. BER with AFC and with 100 kHz detuning.

The bit error rate (BER) for a given unmodulated carrier IF SNR decreases as the IF bandwidth is increased (see Figure [2-12](#)). This fact is very misleading because the IF SNR cannot stay constant unless the transmitted power (or some other parameter) is increased. A fair comparison requires that the other link parameters remain constant while the parameter of interest is varied. This means that the bandwidth must remain constant when other parameters are varied. Using a bandwidth equal to the bit rate (as long as the bit rate is fixed) achieves this goal. The bit error rate versus IF SNR for IF bandwidths wider than 3 times the bit rate is nearly the same because the instantaneous signal suffers very little attenuation due to IF filtering. Most receiver IF filters are quite flat over the middle 25 percent of their 3 dB bandwidth. However, if we plot the BER versus IF SNR in a bandwidth equal to the bit rate (see Figure [2-13](#)), we can readily see that the use of wide IF bandwidths greatly degrades the data quality. The use of an IF bandwidth equal to three times the bit rate requires 3 to 3.5 dB more IF SNR in a bandwidth equal to the bit rate than does the use of an IF bandwidth equal to the bit rate. This is equivalent to doubling the transmitted power. The use of an IF bandwidth equal to 1.5 times the bit rate usually causes a degradation of less than 1 dB. This is illustrated in Figure [2-14](#).

2.2.6 Selection of Demodulator Video Bandwidth. The demodulator video bandwidth should not be set to a value that is less than one-half the bit rate. The preferred choice is usually a value between 0.7 and one times the bit rate; that is, for a 700-kb/s bit rate, the video bandwidth would be set to either 500 or 750 kHz. Note that filtering of the demodulated bit stream is also performed by the bit synchronizer. The use of narrow demodulator video filters, that is, less than 0.7 times the bit rate, will have the effect of making the PCM bit stream look "cleaner" to the eye, but may degrade the data quality. The reason is that the amplitude of the single bits is reduced more than the noise components. One exception does exist; if the bit synchronizer does not include a filter, but rather only samples the incoming data bit stream, the receiver video filter should be set to approximately 0.5 times the bit rate. The effect of video filtering is illustrated in Figure [2-15](#), Figure [2-16](#), and Figure [2-17](#).

2.2.7 Selection of PCM Bit Synchronizer Bit Detector. The use of a filter and sample (F/S) bit detector in the bit synchronizer system is usually the best choice for NRZ PCM/FM data. The only exceptions to the recommended filter and sample detector are in applications involving either excessive or minimal filtering of the data. In the case involving excessive filtering of the PCM signal prior to the PCM bit synchronizer, a sample bit detector may provide the best results; however, most modern bit synchronizer systems do not provide a sample bit detector as an option. In the case of an essentially unfiltered PCM data stream, the integrate and dump (I/D) bit detector may provide improved performance over that of the sample bit detector selection. However, the difference in performance is nearly insignificant because most of the bit errors are the result of noise pops under the conditions involving a wide IF bandwidth relative to the bit rate and essentially no other filtering.



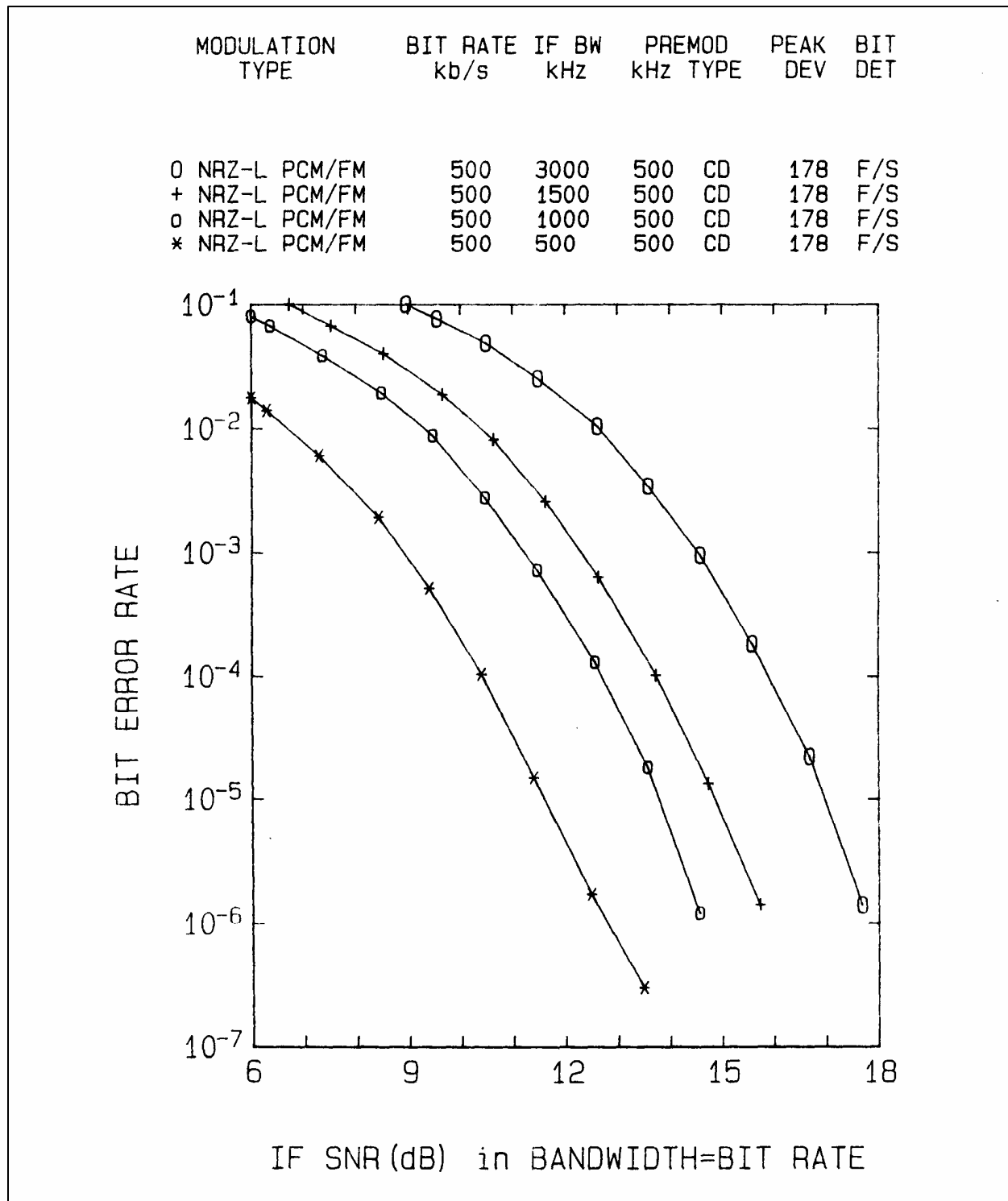

Figure 2-13. BER with IF BW/bit rate = 1, 2, 3, and 6.

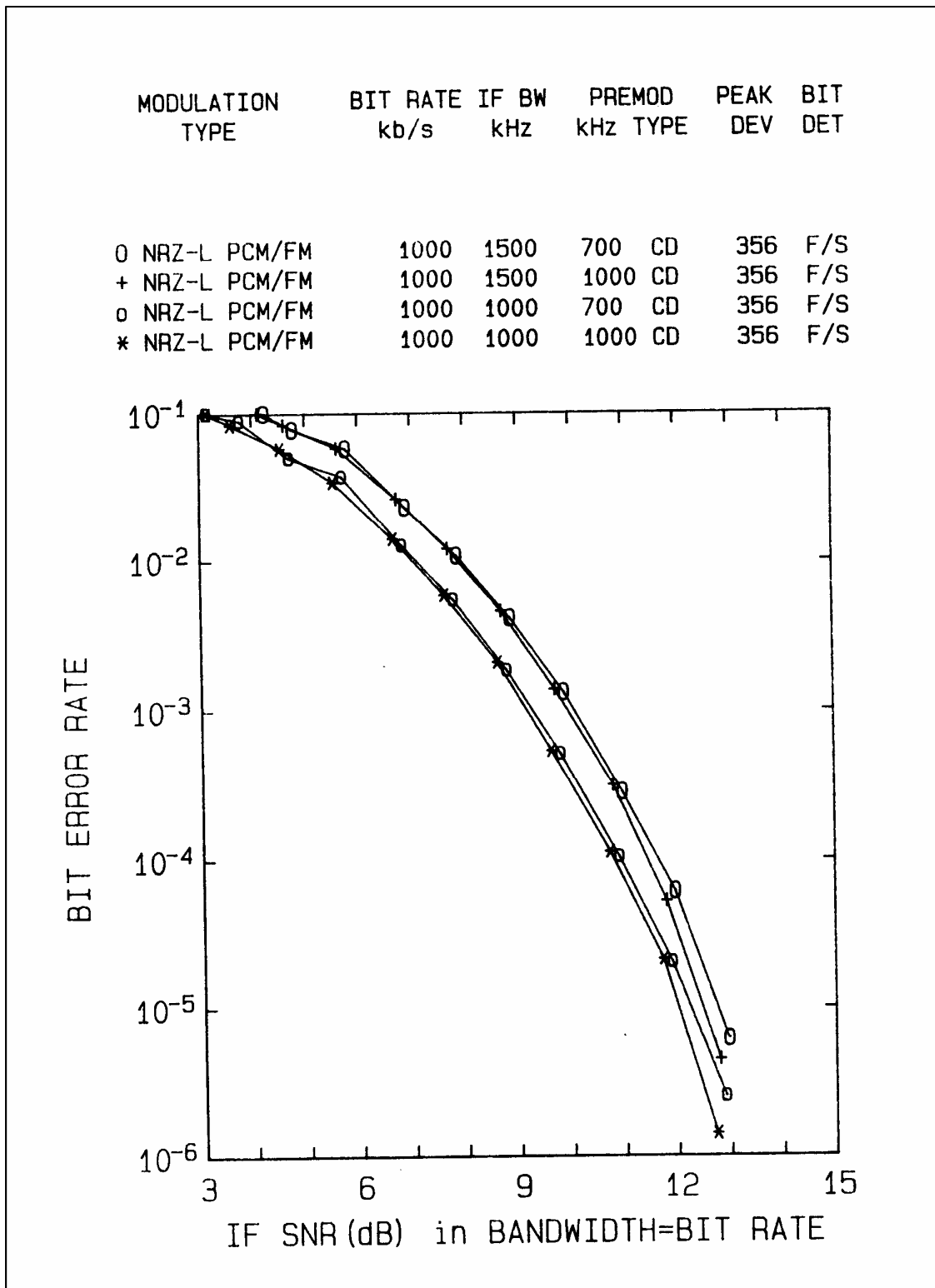

Figure 2-14. BER with IF BW bit rate = 1 and 1.5.

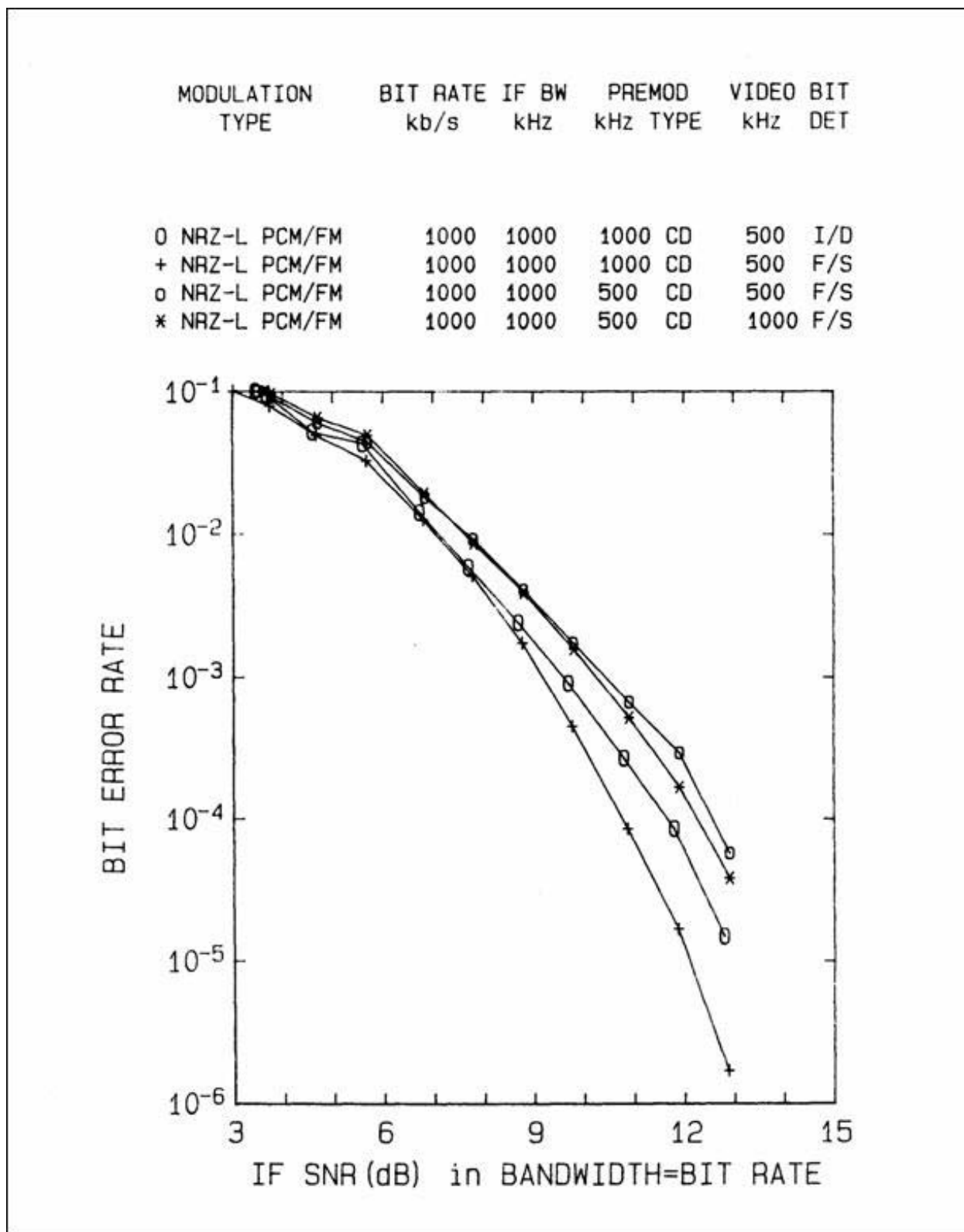

Figure 2-15. BER with video and PREMOD BWs = 0.5 and 1 bit rate.

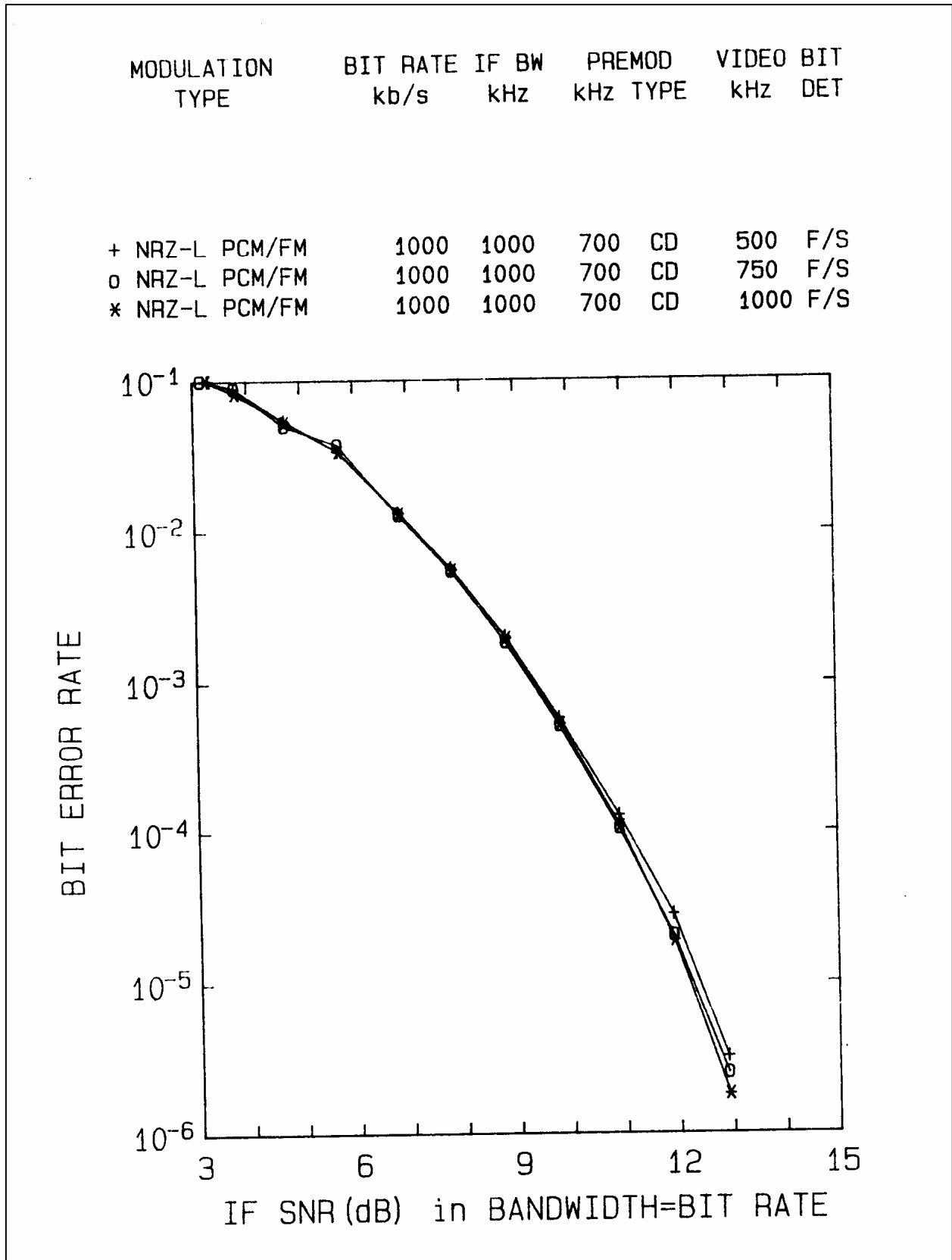

Figure 2-16. BER with video BW = 0.5, 0.75, and 1 bit rate.

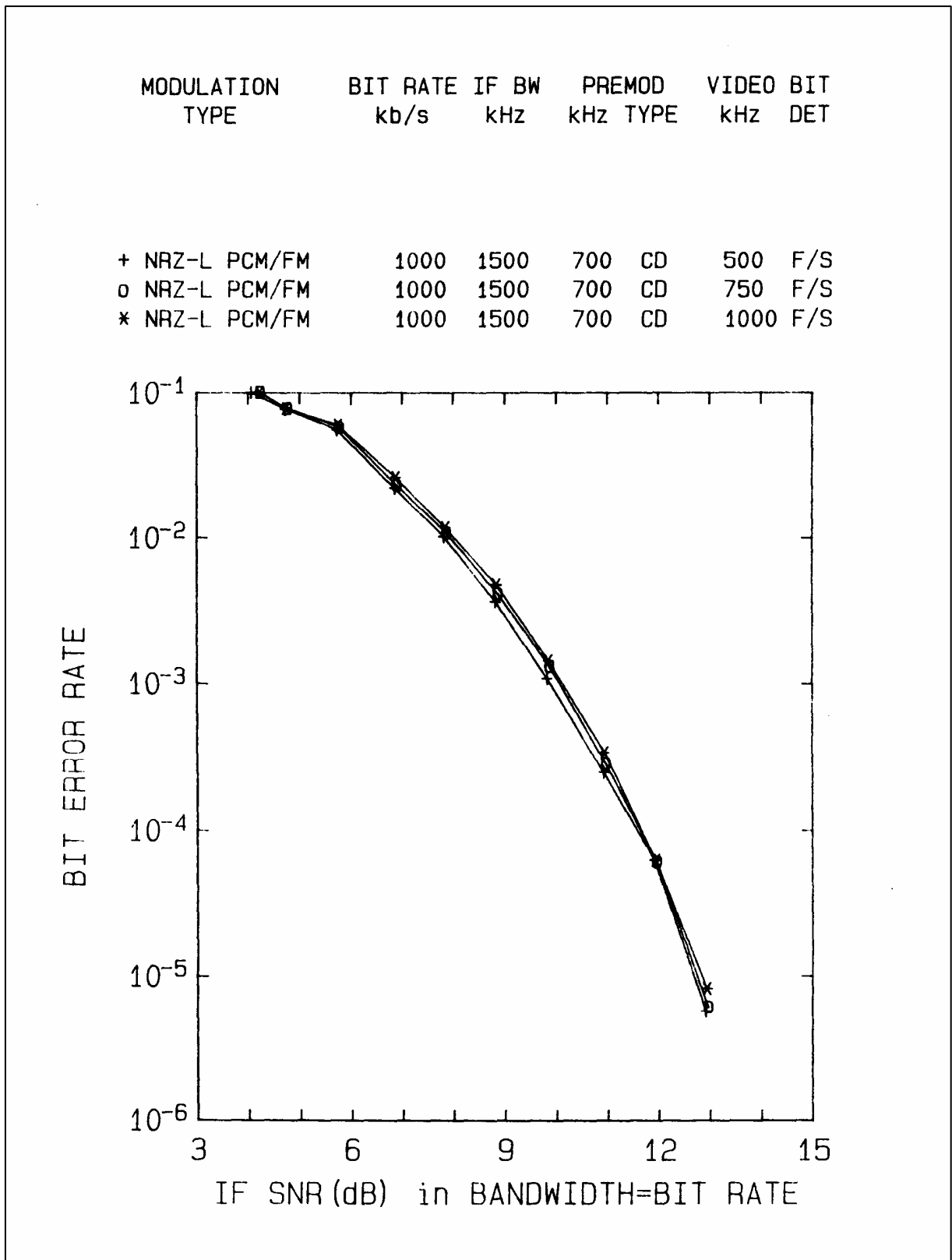

Figure 2-17. BER with video BW = 0.5, 0.75, and 1 bit rate.

2.2.8 RF Spectra. The measured RF spectrum of pseudo-random (pseudo-noise (PN)) NRZ PCM/FM data using a peak deviation equal to 0.356 times the data bit rate (premodulation filter not used) is shown in Figure 2-18. The frequency scale is relative to the center frequency for all RF spectral plots. Approximately 91 percent of the spectral power shown in Figure 2-18 is contained in a bandwidth equal to the bit rate. The bandwidth containing 99 percent of the power (NTIA occupied bandwidth) is 1.42 MHz. This is equal to 1.78 times the bit rate. This value is quite close to the calculated value of 1.8 times the bit rate for rectangular NRZ PCM/FM with peak deviation equal to 0.35 times the bit rate listed by Korn (Reference 2i). The RF spectra for pseudo-random NRZ PCM/FM with peak deviation values corresponding to 0.1, 0.175, 0.25, 0.356, 0.42, 0.5, 0.71, and 1.0 times the bit rate are presented in Figure 2-19 through Figure 2-26, respectively. The premodulation filter used was a 5-pole linear phase filter with the -3 dB roll-off point at 800 kHz for all eight spectra. The 99 percent power bandwidth versus peak deviation for four of the peak deviations listed above is shown in Table 2-1.

The data presented in Table 2-1 reveal that increasing the peak deviation from 0.356 times the bit rate to 0.42 times the bit rate increases the 99 percent power bandwidth by 11.6 percent and increases the -60 dBc bandwidth by 6.4 percent. The -60 dBc bandwidth is defined as the bandwidth beyond which all components are 60 dB below the unmodulated carrier level when measured in a 30-kHz bandwidth. Doubling the peak deviation to 0.712 times the bit rate increases the 99 percent power bandwidth by 43.8 percent and increases the -60 dBc bandwidth by 45.1 percent.

The effect on the RF spectrum as a result of using a variety of premodulation filter types is shown in Figure 2-22, and Figure 2-27 through 2-33. The 99 percent power bandwidths, the -60 dBc bandwidths, and the percentage of the power in a bandwidth equal to the bit rate are shown in Table 2-2.

The spectrum of unfiltered random NRZ PCM/FM (valid when $D \neq \text{integer}$, $D = 0.5$ gives MSK spectrum) can be calculated using the following equation (Reference 2j):

$$S(f) = \frac{4 B_{SA}}{R} \left(\frac{D}{\pi(D^2 - X^2)} \right)^2 \frac{(\cos \pi D - \cos \pi X)^2}{1 - 2 \cos \pi D \cos \pi X + \cos^2 \pi D}, \quad \cos \pi D < Q \quad (2-1)$$

where

- S(f) = power spectrum (dBc) at frequency f
- B_{SA} = spectrum analyzer resolution bandwidth
- R = bit rate
- D = $2\Delta f/R$
- X = $2(f-f_c)/R$
- Δf = peak deviation
- f_c = carrier frequency
- δ = Dirac delta function
- Q = quantity related to narrow band spectral peaking when $D \approx 1, 2, 3, \dots$
- Q ≈ 0.99 for $B_{SA} = 0.003 R$, Q ≈ 0.9 for $B_{SA} = 0.03 R$

The above equation can be modified to approximate the effects of filtering (Reference 2k

and Reference 21). The filtered NRZ PCM/FM spectrum can be seen by opening the Excel file PCM-FM-SPECTRUM-b.xls. Equation 2-1 can be used to develop an estimate of peak deviation. It turns out that Δf can be estimated using

$$\Delta f = R - \frac{\text{null spacing}}{2} \quad (2-2)$$

where null spacing is the frequency spacing between the closest spectral nulls on each side of the center frequency.

The parameters in cells J2, K2, L2, and M2 can be varied to see the effect on the RF spectrum.

The data in Table 2-2 reveal that the 99 percent power bandwidth is usually narrower with a Bessel (constant delay (CD)) premodulation filter than with a Butterworth (constant amplitude (CA)) filter. The wider bandwidth is partially the result of the much larger overshoot of the Butterworth filter. The frequency deviation caused by the overshoot exceeds the nominal peak deviation (in this case 285 kHz) which is defined as the peak deviation without overshoot. The Bessel filter also attenuates signals below the -3 dB cutoff more than the Butterworth filter; however, outside the passband of the filter characteristic (above the -3 dB cutoff), the opposite is true. The 99 percent power bandwidth and the percentage of power in a bandwidth equal to the bit rate agree quite closely for the 5-pole Bessel and the 1-pole R-C premodulation filters. It should be noted, however, that the -60 dBc bandwidth is significantly narrower for the 5-pole Bessel filter than for the 1-pole R-C filter. The reason for the differences in the response of the filters is that the 1-pole R-C filter attenuation increases significantly more slowly than the attenuation of the Bessel filter at frequencies above the -3 dB point. The attenuation of the two filters is similar at frequencies below the -3 dB cutoff point.

All of the RF spectra presented in Figure 2-18 through Figure 2-33 were recorded with a spectrum analyzer resolution bandwidth of 30 kHz. Figure 2-34 is similar to Figure 2-18 except the resolution bandwidth has been decreased to 3 kHz and the video bandwidth increased to 300 Hz. The sweep time in Figure 2-34 was 15 seconds, while the sweep time in Figure 2-18 was 5 seconds. To decrease the trace width of Figure 2-34 to the width of Figure 2-18, would require that the sweep time be 500 seconds. Consequently, the 30-kHz resolution bandwidth was chosen for the spectral displays in these descriptions. To convert the spectral amplitudes between the two filter bandwidths, it is necessary to subtract 10 dB ($10 \log 3/30$) from the 30-kHz value if the input is white noise. When the input contains discrete frequency components (delta functions in the frequency domain), the amplitude at the output of both filters would be the same; this assumes only one discrete component within the passband of the widest filter. If discrete spectral components are not present, -50 dBc with a 30-kHz spectrum analyzer bandpass filter is essentially the same as -60 dBc with a 3-kHz bandpass filter. In reality, many discrete spectral components are present in this case, but the sum of many discrete spectral components looks like noise as far as the bandpass filter is concerned. In this case, it is not possible to extend the extrapolation to a 100-Hz bandpass filter because the spectral components are spaced every $800,000/2047$ Hz or approximately 391 Hz apart, so, a 100-Hz bandpass filter would resolve the individual components.

Figure 2-35 and Figure 2-36 show the spectra that result when the bit stream contains a repeating 16-bit word. The 16-bit word for Figure 2-35 was "1111000100110100", which is a 15-bit pseudo-noise sequence with a zero added at the end for symmetry. The 16-bit word for Figure 2-36 was "101000100010000", which is the word from Figure 2-35 with every other "1" converted to a "0." The spectrum in Figure 2-36 is obviously not symmetrical. The spectrum in Figure 2-35 is somewhat symmetrical, but there are significant differences between the upper and lower halves of the spectrum. In general, FM spectra are not symmetrical unless the input to the FM modulator is symmetrical. For example, a single sine wave modulating an FM generator produces a symmetrical RF spectrum.

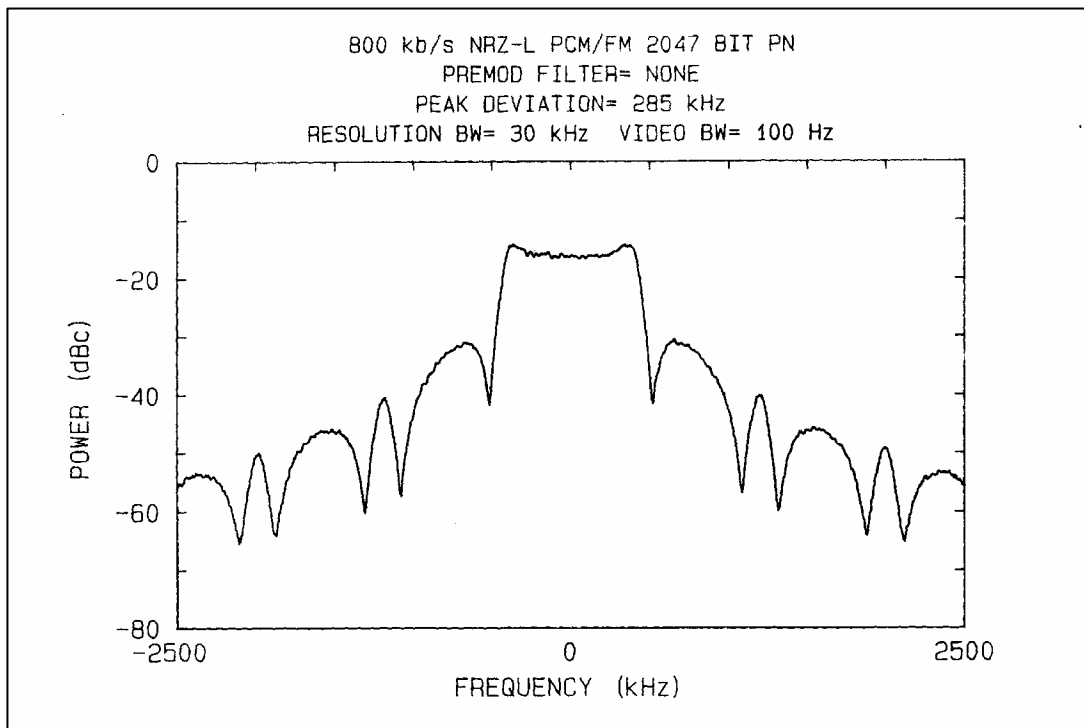

Figure 2-18. NRZ PCM/FM spectrum (no PREMOD, peak DEV = 0.35 bit rate).

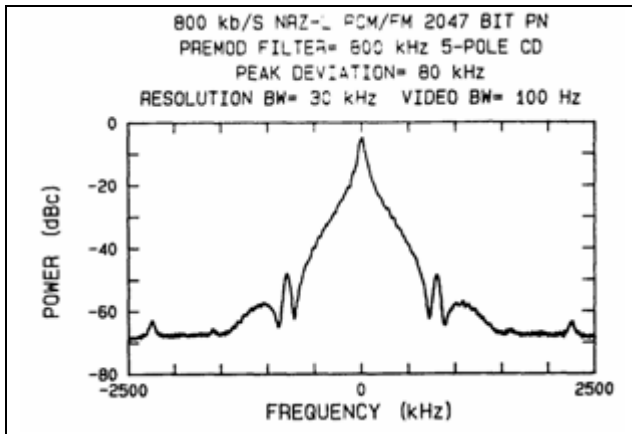

Figure 2-19. RF spectrum PREMOD = 800 kHz CD peak DEV = 0.1 bit rate.

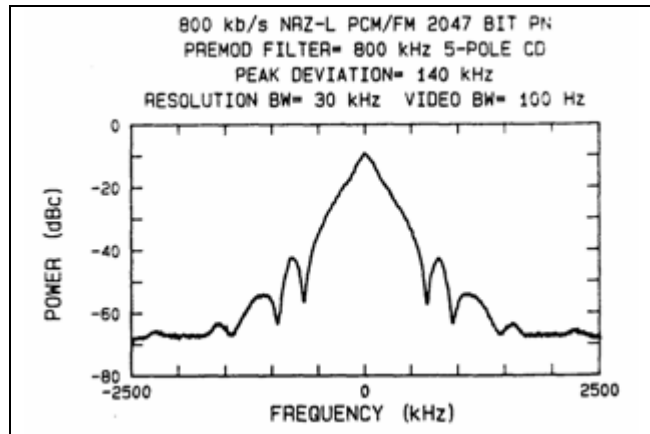

Figure 2-20. RF spectrum PREMOD = 800 kHz CD peak DEV = 0.175 bit rate.

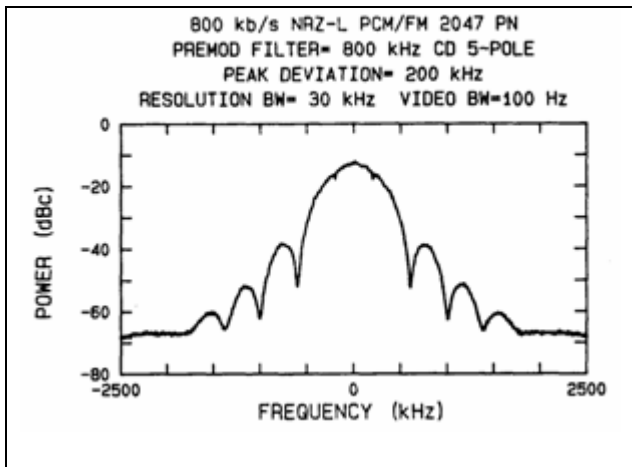

Figure 2-21. RF spectrum PREMOD = 800 kHz CD peak DEV = 0.25 bit rate.

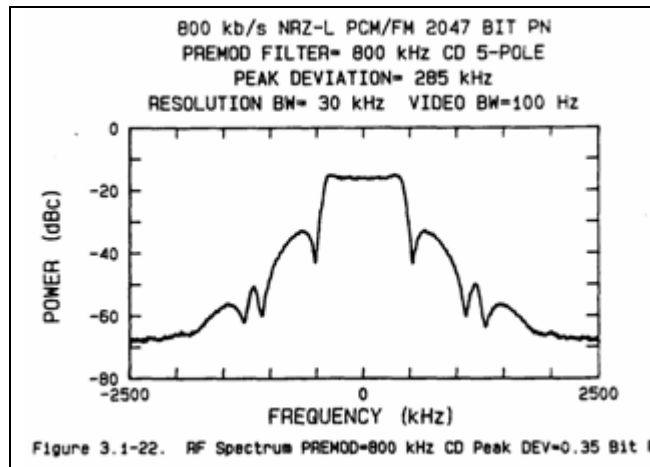

Figure 2-22. RF spectrum PREMOD = 800 kHz CD Peak DEV=0.35 Bit

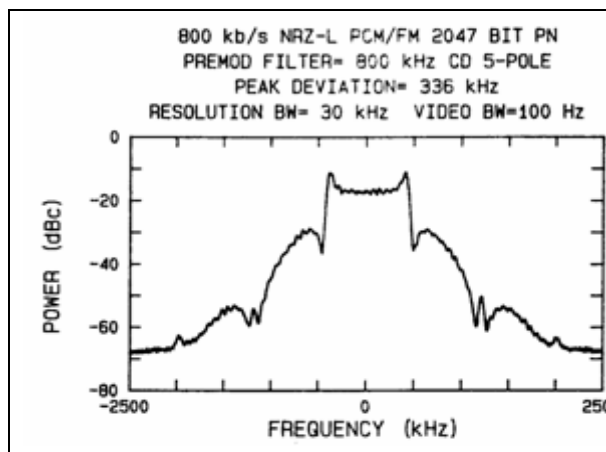

Figure 2-23. RF spectrum PREMOD = 800 kHz CD peak DEV = 0.42 bit rate.

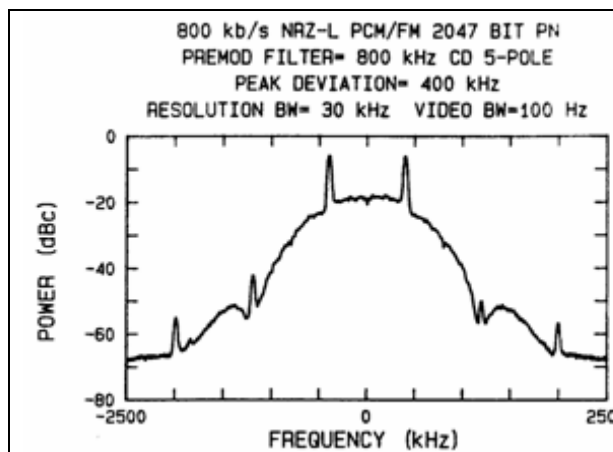

Figure 2-24. RF spectrum PREMOD = 800 kHz CD peak DEV = 0.50 bit rate.

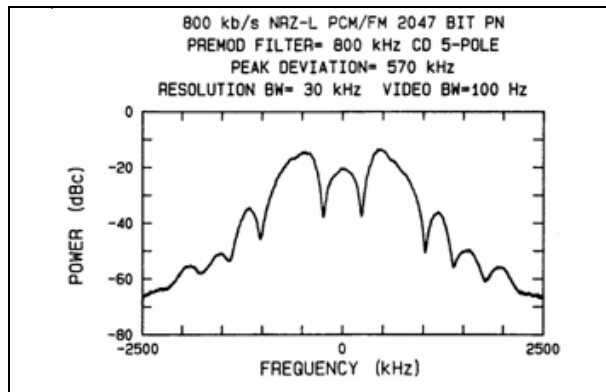

Figure 2-25. RF spectrum PREMOD = 800 kHz CD peak DEV = 0.71 bit rate.

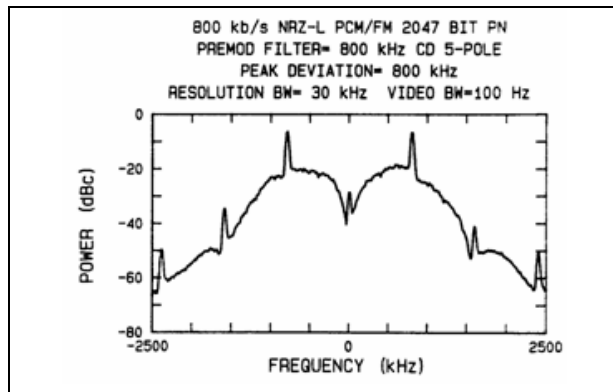

Figure 2-26. RF spectrum PREMOD = 800 kHz CD peak DEV = 1.00 bit rate.

TABLE 2-1. RF SPECTRAL CHARACTERISTICS FOR VARIOUS PEAK DEFINITIONS

| 800 kb/s NRZ-L PCM/FM 800 kHz 5-pole Linear Phase Premodulation Filter | | | | | |
|---|-----------|-------------------------------|-----------|------------------------------------|--|
| Peak Deviation kHz | /Bit Rate | 99% Power Bandwidth kHz | /Bit Rate | IRIG -60 dBc Bandwidth (kHz) | % of Power in BW Equal to the Bit Rate |
| 200 | 0.25 | 900 | 1.13 | 1910 | 97.6 |
| 285 | 0.356 | 1210 | 1.51 | 2040 | 92.0 |
| 336 | 0.42 | 1350 | 1.69 | 2170 | 83.7 |
| 570 | 0.712 | 1740 | 2.18 | 2960 | 23.7 |

TABLE 2-2. RF SPECTRAL CHARACTERISTICS FOR VARIOUS PREMODULATION FILTERS

| 800 kb/s NRZ-L PCM/FM 285 kHz Peak Deviation | | | | | |
|---|------|---------------------------|-----------|------------------------------|--|
| Premodulation Bandwidth (kHz) | Type | 99% Power Bandwidth (kHz) | /Bit Rate | IRIG -60 dBc Bandwidth (kHz) | % of Power in BW Equal to the Bit Rate |
| None | | 1420 | 1.78 | 4010 | 91.0 |
| 800 | CD | 1210 | 1.51 | 2040 | 92.0 |
| 800 | CA | 1330 | 1.66 | 2390 | 90.6 |
| 560 | CD | 930 | 1.16 | 2010 | 93.9 |
| 560 | CA | 950 | 1.19 | 2020 | 93.5 |
| 400 | CD | 890 | 1.11 | 1860 | 95.6 |
| 400 | CA | 890 | 1.11 | 1830 | 95.5 |
| 800 | RC | 1200 | 1.50 | 2500 | 92.6 |
| 560 | RC | 940 | 1.18 | 2500 | 93.7 |

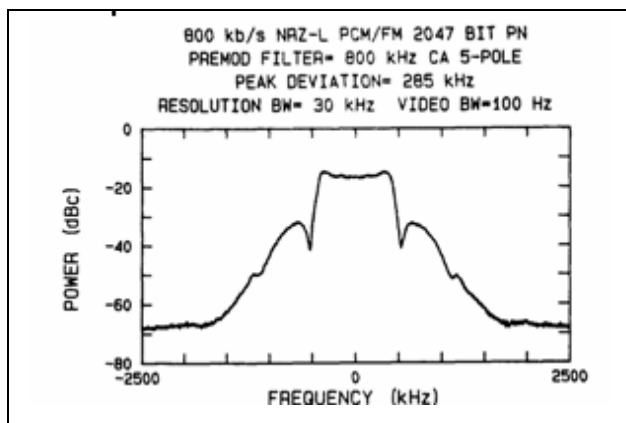

Figure 2-27. RF spectrum PREMOD = 800 kHz CA peak DEV = 0.35 bit rate.

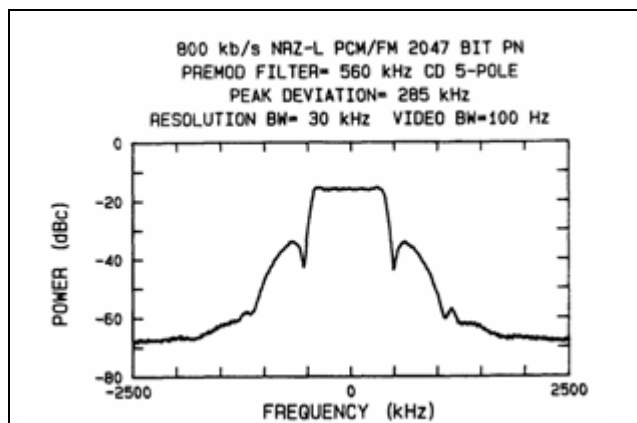

Figure 2-28. RF spectrum PREMOD = 560 kHz CD peak DEV = 0.35 bit rate.

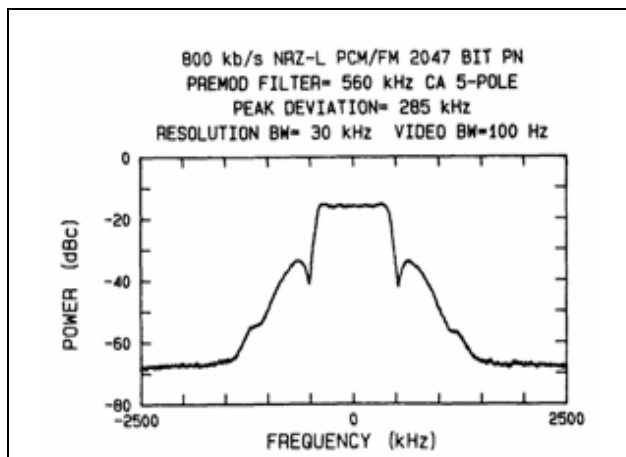

Figure 2-29. RF spectrum PREMOD = 560 kHz CA peak DEV = 0.35 bit rate.

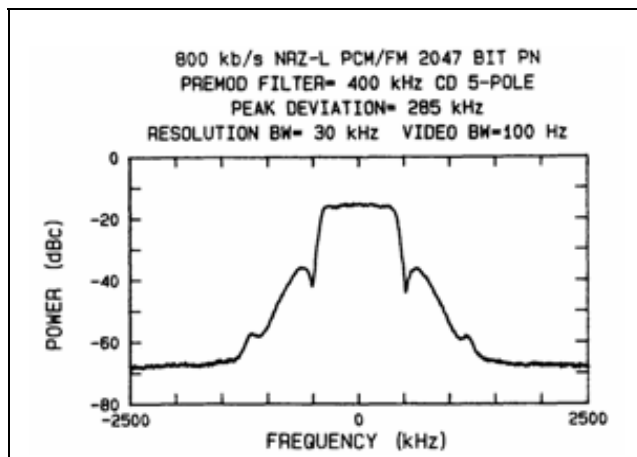

Figure 2-30. RF spectrum PREMOD = 400 kHz CA peak DEV = 0.35 bit rate.

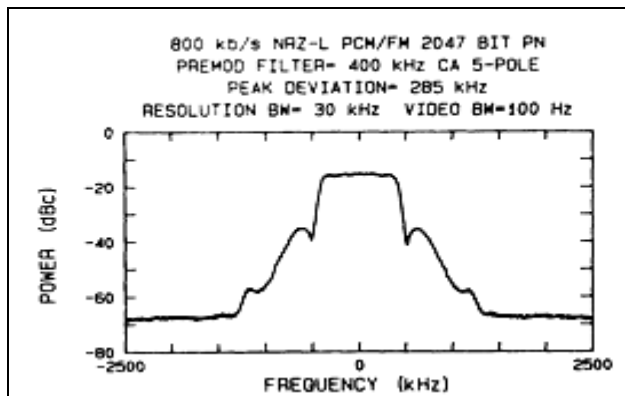

Figure 2-31. RF spectrum PREMOD = 400 kHz CA peak DEV = 0.35 bit rate.

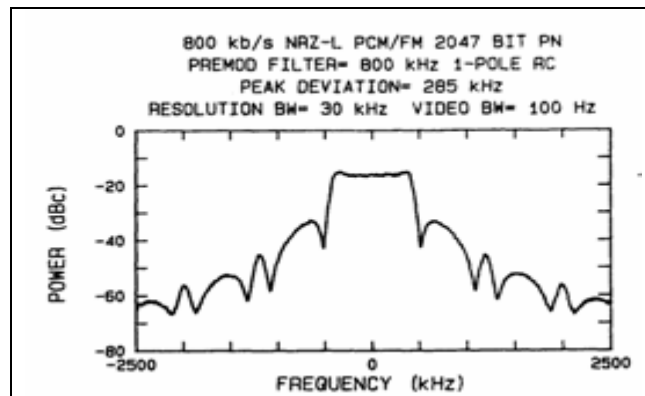

Figure 2-32. RF spectrum PREMOD = 800 kHz CD peak DEV = 0.35 bit rate.

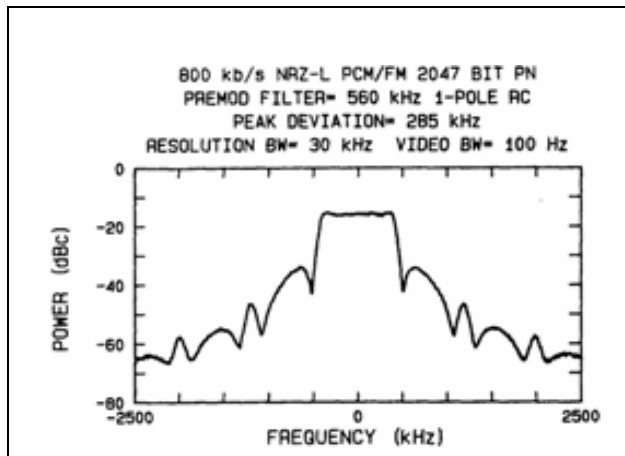

Figure 2-33. RF spectrum PREMOD = 560 kHz RC peak DEV = 0.35 bit rate.

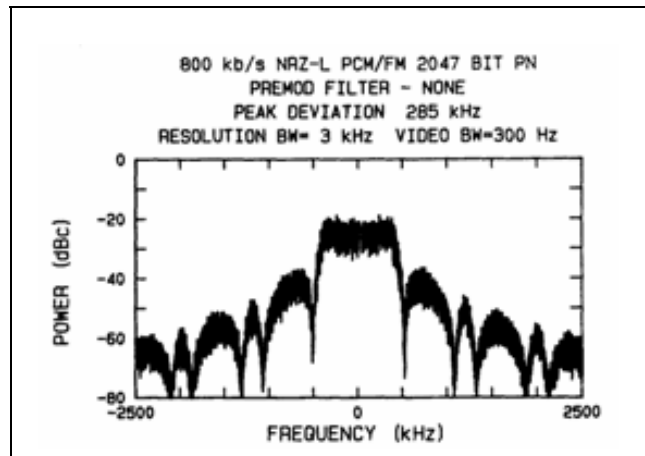

Figure 2-34. RF spectrum PREMOD=None peak DEV = 0.35 bit rate (3 kHz).

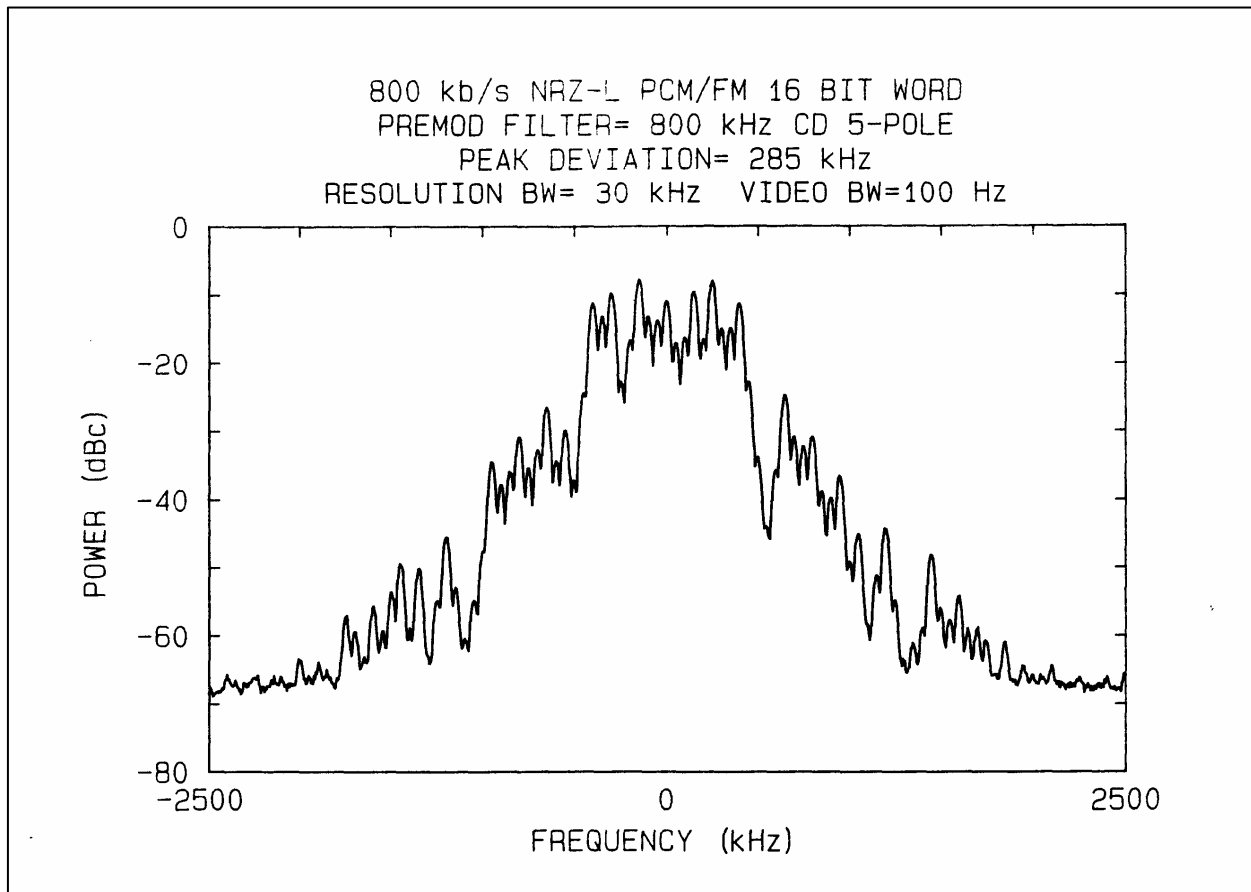

Figure 2-35. NRZ PCM/FM AF spectrum with repeated 16-bit word.

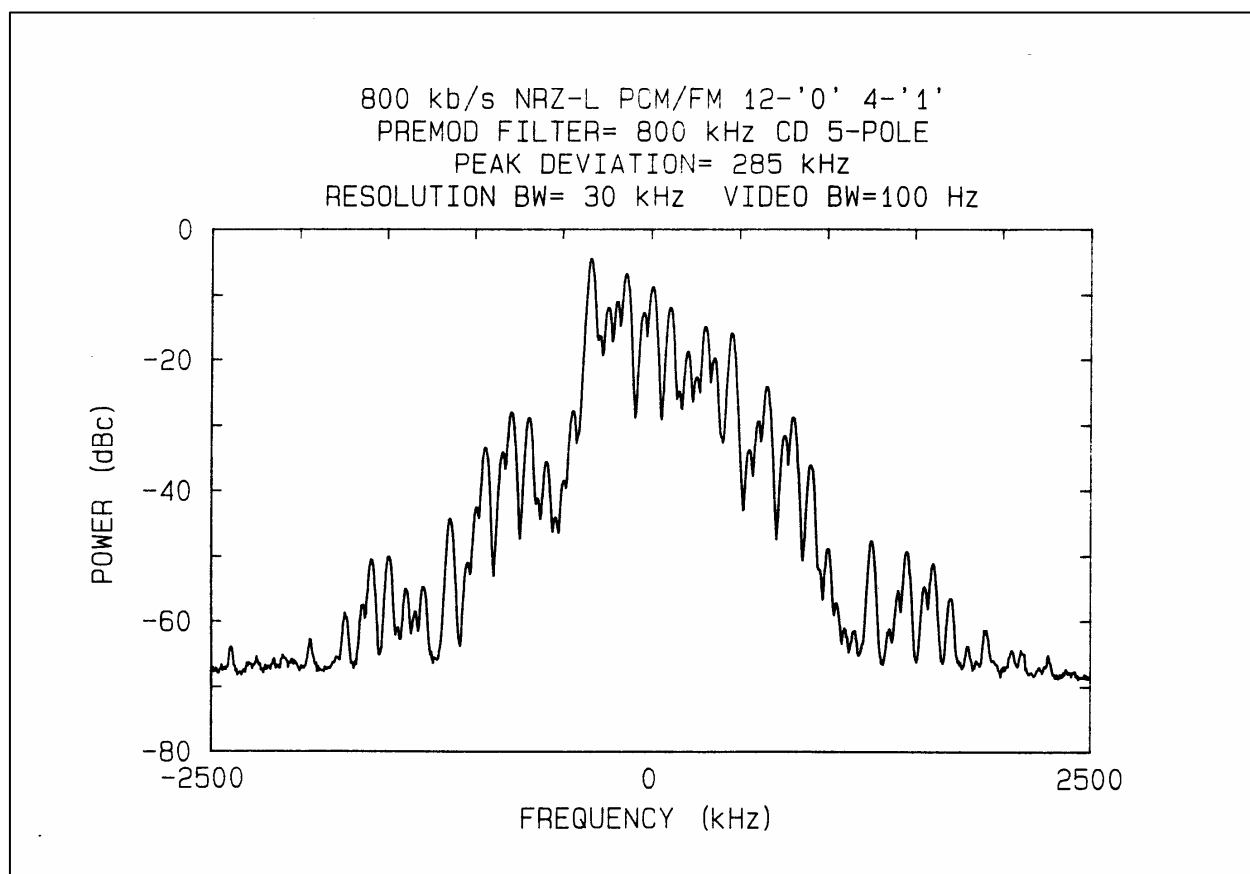

Figure 2-36. NRZ PCM/FM RF spectrum with repeated 16-bit word (3/4 zeros).

2.3 Biphase PCM/FM

2.3.1 Introduction. Biphase pulse code modulation/frequency modulation (PCM/FM) is a method used to send digital data over a transmission link. The most commonly used code for biphase PCM/FM is the level (-L) code. This code represents a ONE by a high level for the first half of the bit time and a low level for the second half of the bit time. A zero is the exact opposite of a one.

- a. The advantages of biphase PCM/FM over NRZ PCM/FM include:
 - Biphase has no dc component; therefore, ac-coupled transmitters can be used.
 - Biphase has at least one transition every bit period. This transition makes bit synchronization easier.
- b. The disadvantages of biphase PCM/FM compared to NRZ PCM/FM include:
 - Biphase PCM/FM requires approximately twice the bandwidth of NRZ PCM/FM.
 - Biphase PCM/FM requires approximately 3 dB more IF SNR in a bandwidth equal to the bit rate for the same BER, compared to NRZ PCM/FM.

2.3.2 Selection of Peak Deviation. The optimum peak deviation for biphase PCM/FM is approximately 0.65 times the bit rate; that is, a 1.0 Mb/s bit stream should have a peak deviation of 650 kHz and a peak-to-peak deviation of 1,300 kHz (Reference [2m](#)). This optimum value of peak deviation is valid when using IF bandwidths that are between 1.8 and 4 times the bit rate and for systems where the incidental FM is much less than the peak deviation. If the predetection bandwidth is wider than four times the bit rate, the optimum peak deviation is greater than 0.65 times the bit rate (see Figure [2-37](#)). If the predetection bandwidth is much wider than the bit rate, biphase PCM/PM will usually be a better choice than biphase PCM/FM because of its better BER versus IF SNR performance. The BER versus IF SNR performance of biphase PCM/FM is shown in Figure [2-38](#) and Figure [2-39](#) for peak deviations equal to 0.50, 0.65, and 0.80 times the bit rate and IF bandwidths of two and three times the bit rate. The IF SNR in a bandwidth equal to the bit rate for a 10^{-4} BER was 13.5 dB for an IF bandwidth equal to twice the bit rate and 14.4 dB for an IF bandwidth equal to three times the bit rate with a peak deviation equal to 0.65 times the bit rate.

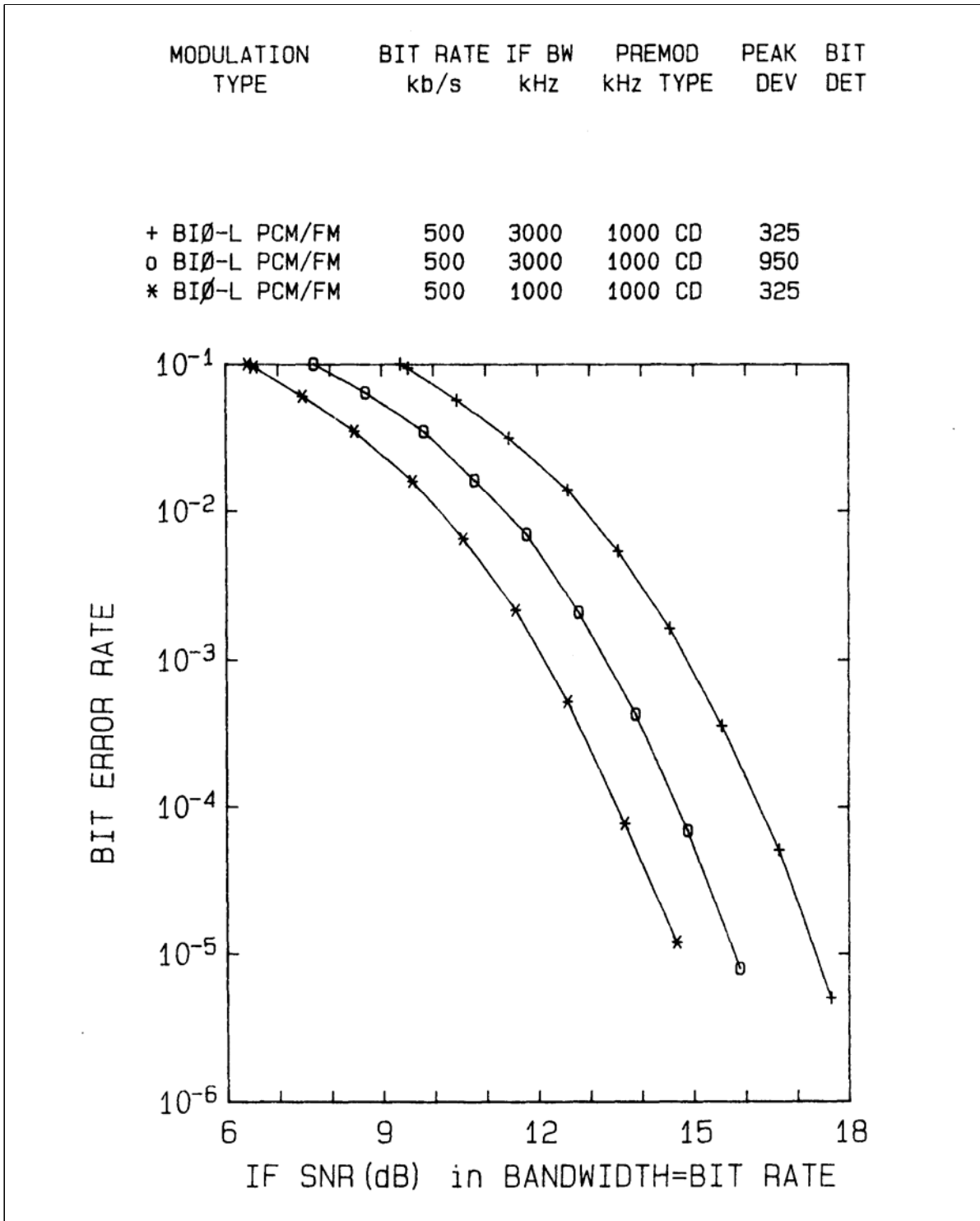

Figure 2-37. BER for IF BW = 2 and 6 times bit rate.

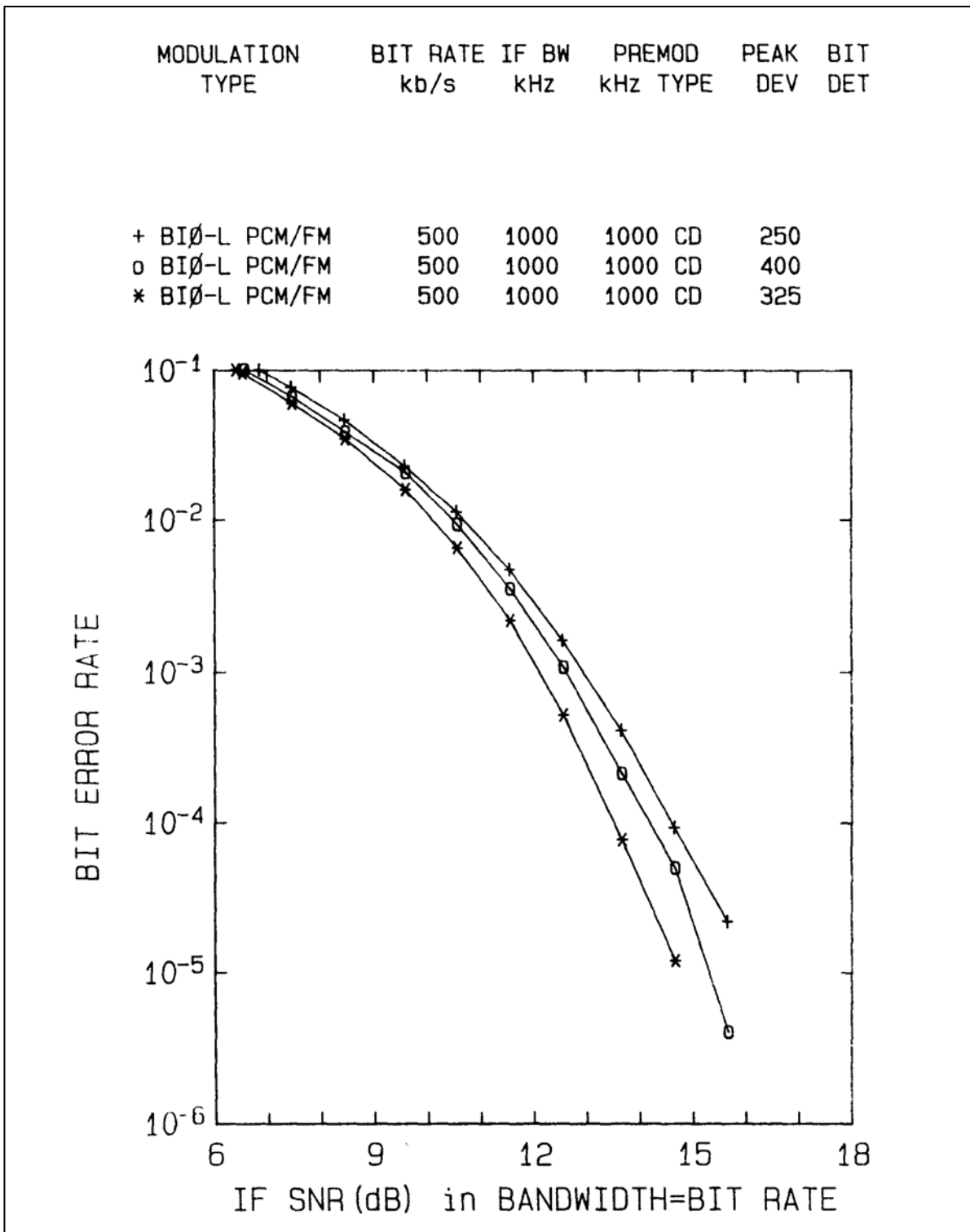

Figure 2-38. BER for peak DEV = 0.5, 0.65, and 0.8 bit rate for IF BW = 2 times bit rate.

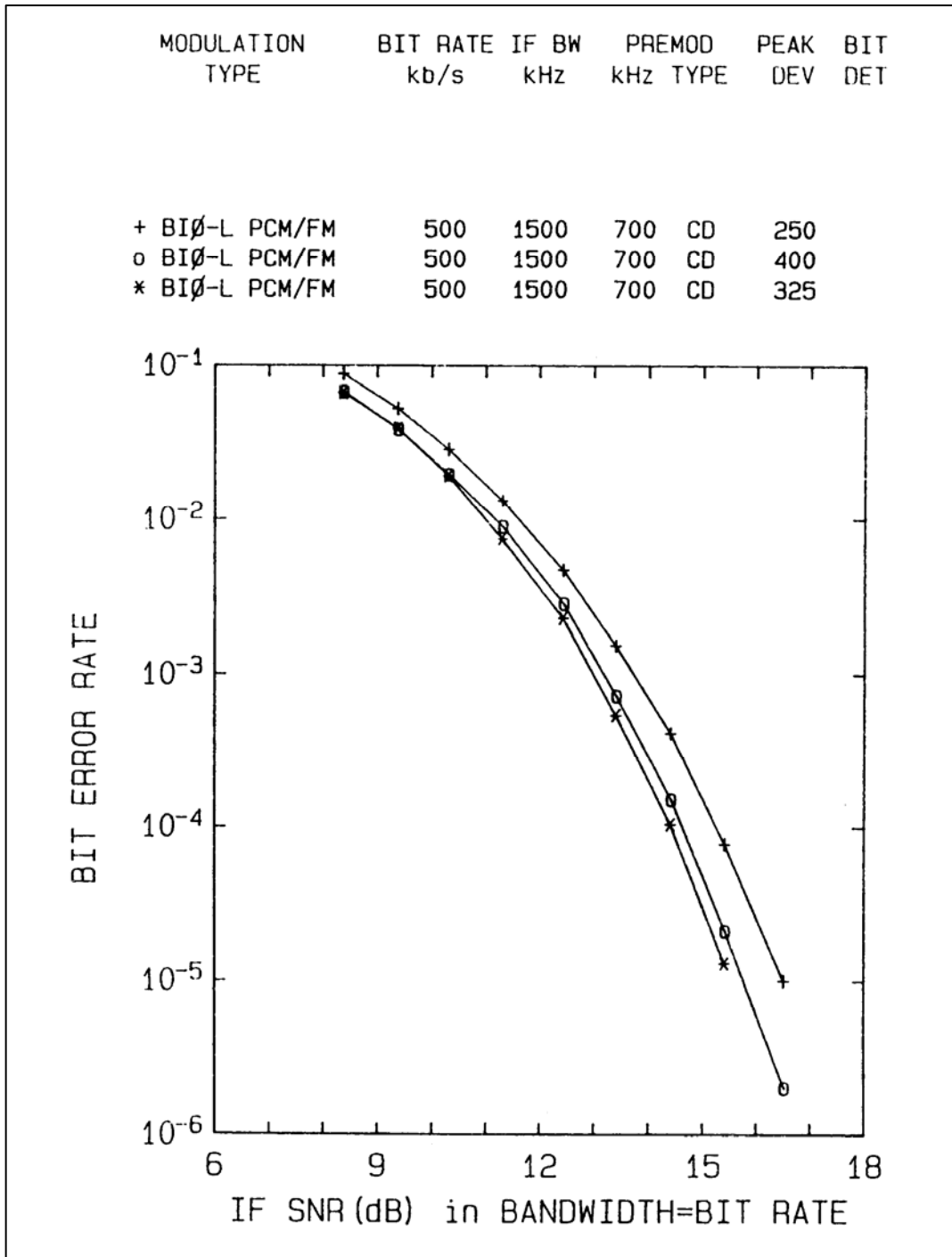

Figure 2-39. BER for peak DEV = 0.5, 0.65, and 0.8 bit rate for IF BR = 3 times bit rate.

2.3.3 Selection of Premodulation Filter. The best classical low pass premodulation filter to use with NRZ PCM/PM (90) is a linear phase filter with the widest bandwidth that allows the RF spectral occupancy requirements to be met. A low-pass filter with a -3 dB bandwidth equal to or greater than 1.4 times the bit rate will not cause a significant increase in the BER (see Figure [2-40](#)). The use of a premodulation filter bandwidth equal to the bit rate degrades the data quality by at least 1 dB for BERs of 10^{-4} (and lower). The BER versus IF SNR performance is essentially the same with linear phase and constant amplitude premodulation filters.

2.3.4 Selection of Receiver IF Bandwidth. The optimum receiver IF bandwidth is equal to approximately two times the bit rate for biphase level PCM/FM. Reference [2m](#) lists an optimum IF bandwidth of 1.8 times the bit rate. The variation of BER with the ratio of IF bandwidth to bit rate is illustrated in Figure [2-41](#). The IF bandwidth was fixed at 1,000 kHz (actually measured to be approximately 1,100 kHz) and the bit rate, premodulation filter bandwidth, and peak deviation were varied. The premodulation filter bandwidth was set to twice the bit rate and the peak deviation was set to 0.65 times the bit rate. For BERs between 10^{-4} and 10^{-5} , the performance at 500 and 600 kb/s was essentially the same and better than the performance at 400 and 700 kb/s. The ratio of measured IF bandwidth to bit rate was approximately 2.2 and 1.8 for 500 and 600 kb/s. The data in Figure 2-41 supports the optimum IF bandwidth setting of approximately twice the bit rate. Figure [2-42](#) shows the BER versus IF SNR performance for bandwidths equal to 2, 3, and 6 times the bit rate. The use of excessively wide IF filters with predetection recording should be avoided. The IF filter should not be wider than two times the predetection carrier frequency. In addition, the biphase bit rate should not exceed one-half of the predetection carrier frequency.

2.3.5 Selection of Demodulator Video Bandwidth. The demodulator video bandwidth should not be set to a value less than the bit rate. There is very little difference in BER performance between video filters with bandwidths between one and three times the bit rate.

2.3.6 Selection of PCM Bit Synchronizer Bit Detector. Most PCM bit synchronizers do not offer a choice of bit detector type for biphase signals.

2.3.7 RF Spectra. Sample biphase level PCM/FM RF spectra are shown in Figure [2-43](#) through Figure [2-48](#). These spectra have spikes at the center frequency and at multiples of the bit rate on both sides of the center frequency. The occupied bandwidth is six times the bit rate for premodulation filter bandwidths equal to the bit rate as well as for a constant amplitude premodulation filter with a bandwidth equal to twice the bit rate for the optimum peak deviation. The occupied bandwidth is equal to eight times the bit rate with a constant delay premodulation filter bandwidth equal to twice the bit rate and the optimum peak deviation. The filters used for these spectral plots were 5-pole low-pass filters.

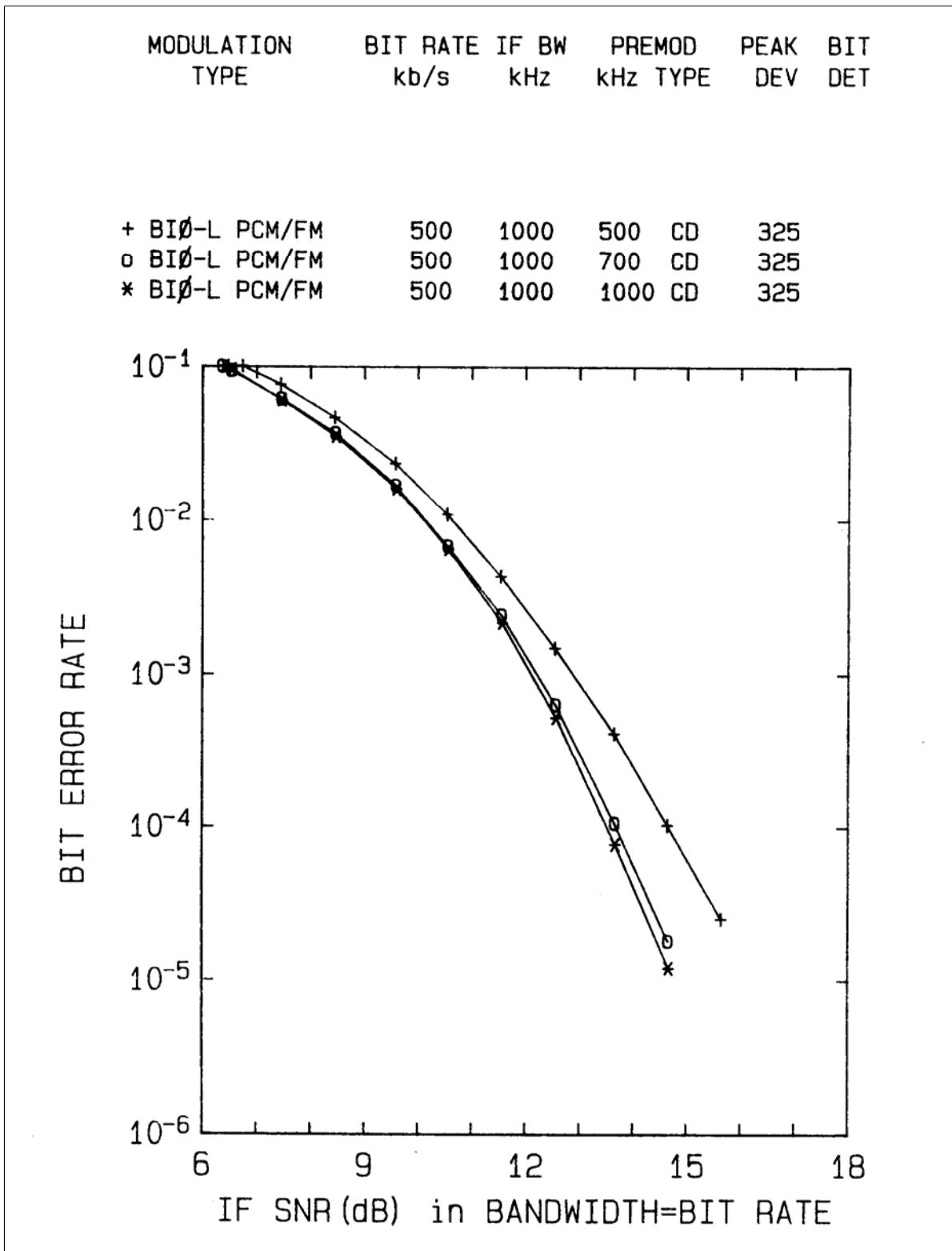

Figure 2-40. BER for PREMOD BW = 1, 1.4, and 2 bit rate.

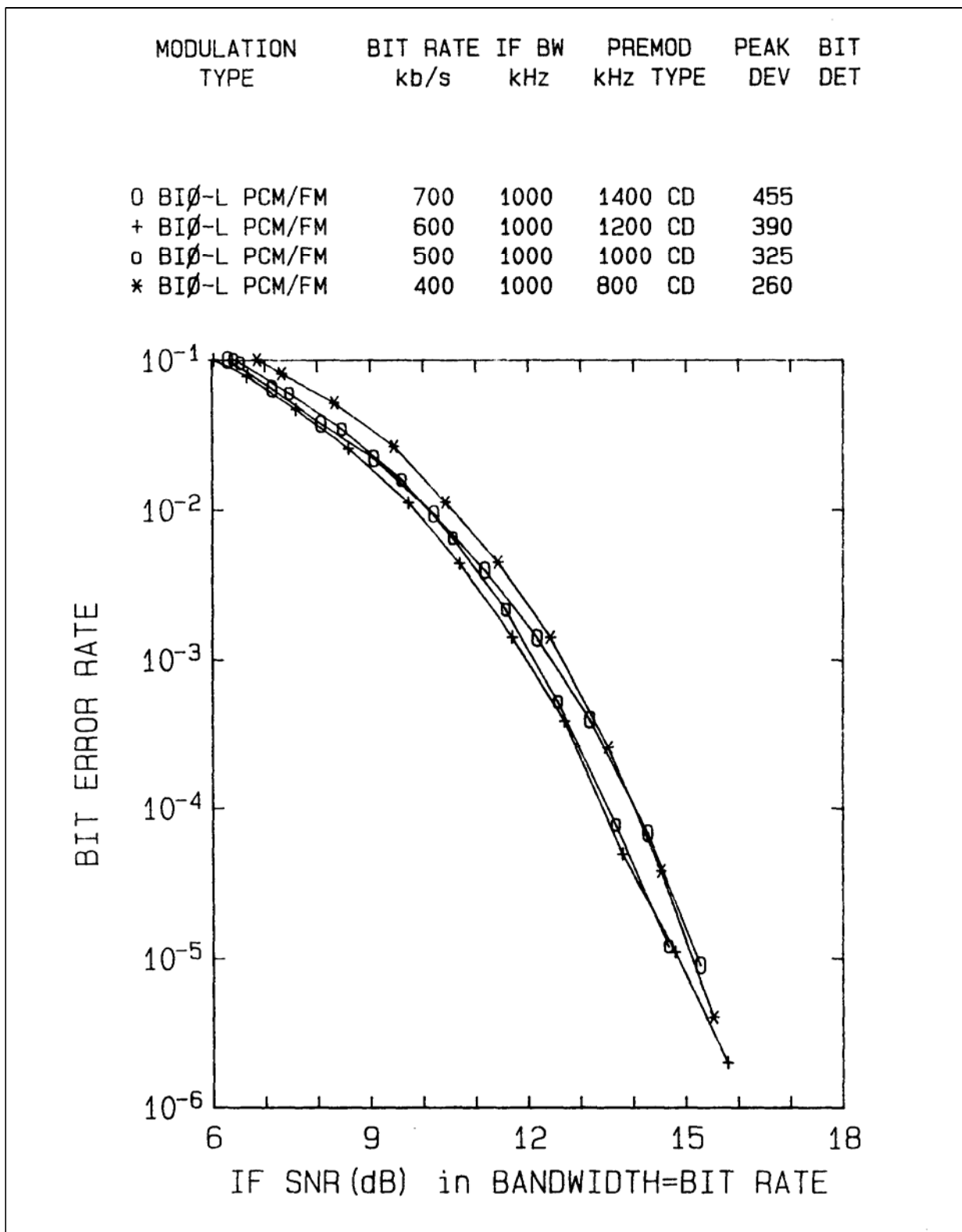

Figure 2-41. BER for IF BW/bit rate = 1.4, 1.67, 2, and 2.5.

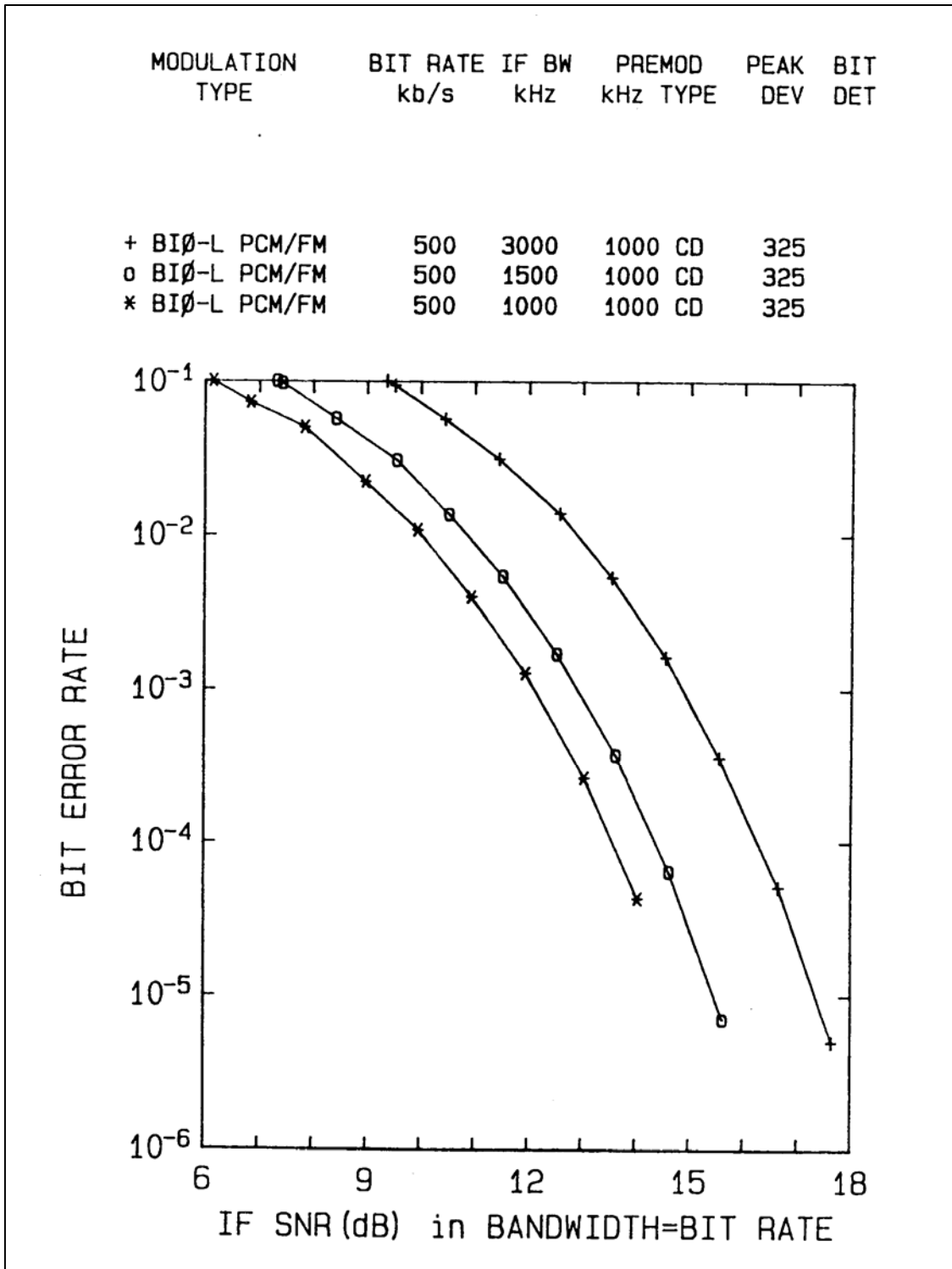

Figure 2-42. BER for IF BW/bit rate = 2, 3, and 6.

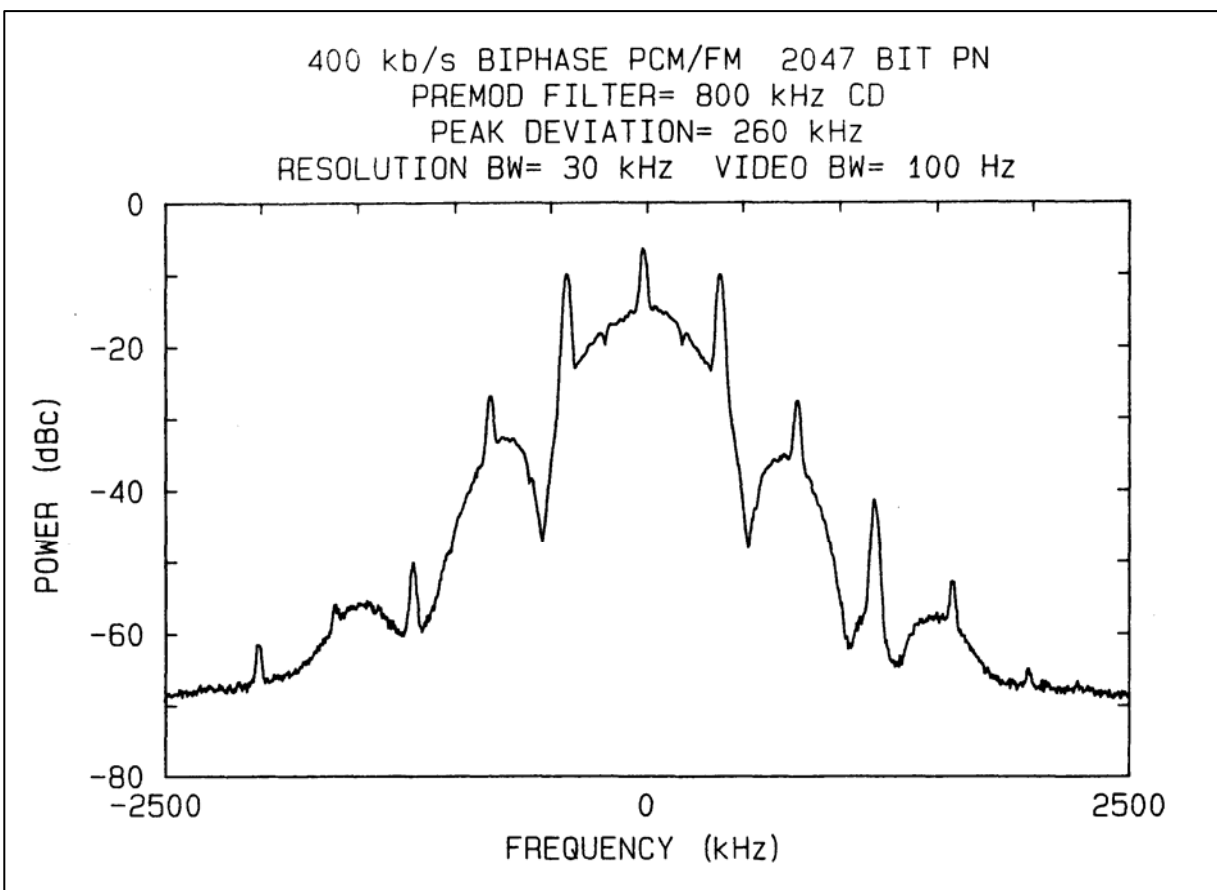

Figure 2-43. Biphase PCM/FM RF spectrum (PREMOD=800 kHz CD, DEV=0.65 bit rate).

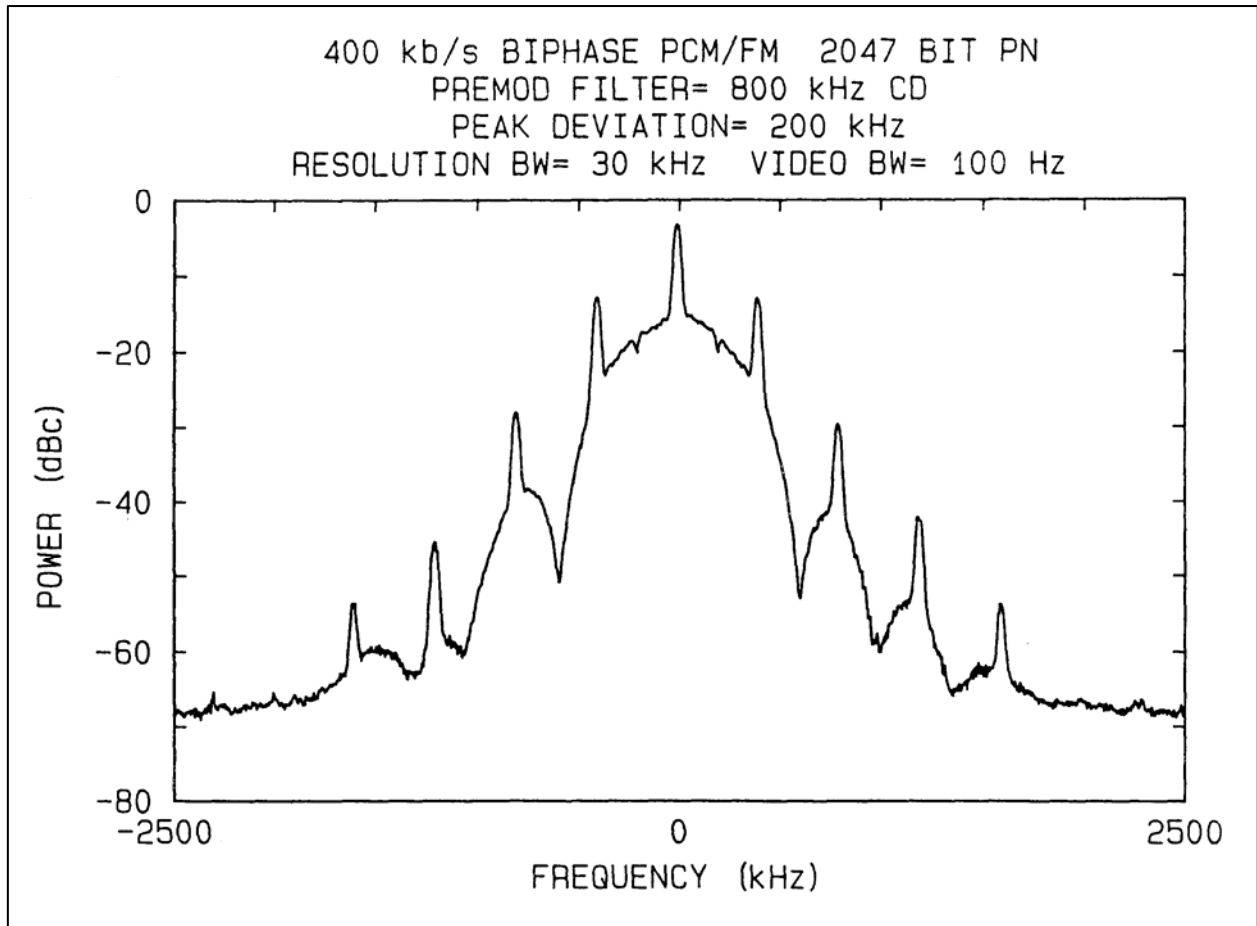

Figure 2-44. Biphase PCM/FM RF spectrum (PREMOD=800 kHz CD, DEV=0.50 bit rate).

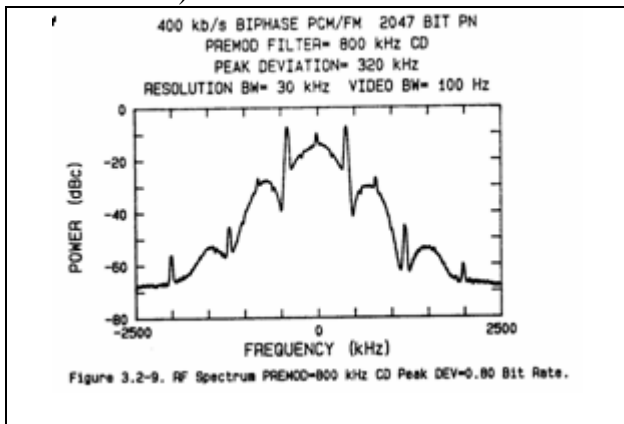

Figure 2-45. RF spectrum PREMOD = 800 kHz CD peak DEV = 0.80 bit rate.

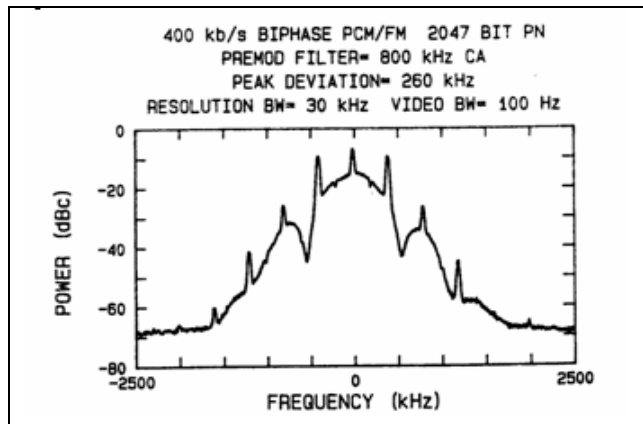

Figure 2-46. RF spectrum PREMOD = 800 kHz CA peak DEV = 0.65 bit rate.

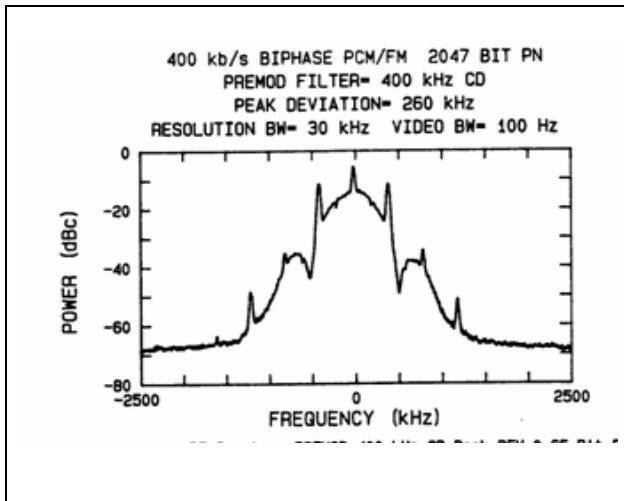

Figure 2-47. RF spectrum PREMOD = 400 kHz CD peak DEV = 0.65 bit rate.

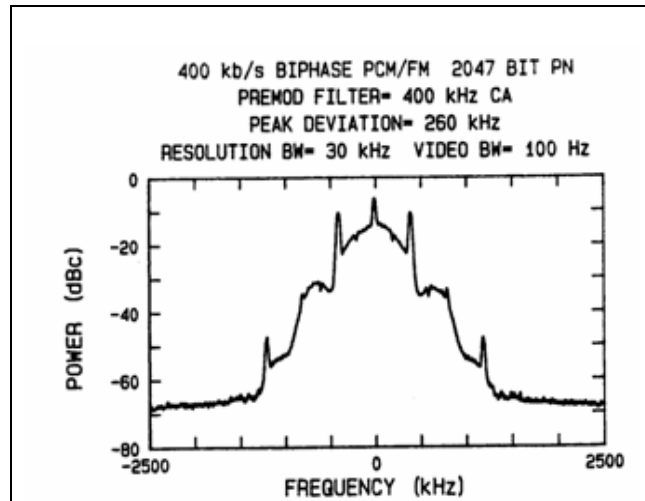

Figure 2-48. RF spectrum PREMOD = 400 kHz CA peak DEV = 0.65 bit rate.

2.4 NRZ PCM/PM

2.4.1 Introduction. Pulse code modulation/phase modulation with 90° peak deviation (PCM/PM (90)) is a method of sending digital data over a transmission link where the carrier phase is shifted +90° to represent one state of a binary signal, and shifted -90° to represent the other state of the binary signal. The most commonly used codes for NRZ PCM/PM (90) are the mark (M) and space (S) codes. The use of the mark and space codes is often called differential encoding because the information is contained in the transitions rather than the levels. The mark and space codes are used because the demodulated output signal when a carrier recovery loop is used has a 180° ambiguity because changing the sign of the received signal does not change the sign of the recovered carrier (Reference [2n](#)). Since the NRZ-M and NRZ-S codes are polarity insensitive, the unknown polarity does not matter.

Bit errors in NRZ PCM/PM (90) are caused by the effects of additive, white, Gaussian noise plus intersymbol interference, timing errors, and other errors. This makes it relatively simple to derive an expression for the bit error rate

$$\text{BER} = 1/2 \operatorname{erfc} \left((E_b/N_0)^{1/2} \cos \phi \right) \quad (2-3)$$

where

E_b is the signal energy per bit
 N_0 is the noise power spectral density (watts/Hz)
 ϕ is the carrier recovery loop tracking error
 erfc is the complementary error function.

Note that this expression assumes unfiltered NRZ-L data and ideal bit detection. The BER for NRZ-M and NRZ-S is approximately twice the BER listed above because each isolated erroneous level causes a transition error on each side of the erroneous level.

2.4.2 Selection of Peak Deviation. The peak carrier deviation that produces the minimum bit error rate is a function of the premodulation filter, the demodulator type and loop bandwidth, and the bit pattern. The bit error rate is relatively insensitive to small changes in the peak deviation. A change in peak deviation from 90° to 100° (or 80°) with no premodulation filtering requires a 0.13 dB (theoretical value) higher SNR to produce the same BER. Figure [2-49](#) through Figure [2-53](#) present BER data versus IF SNR for three different premodulation filter bandwidths and peak deviations of 80°, 90°, and 100°. Two different PSK demodulators were used. They were Model A for Figure [2-49](#) and Figure [2-53](#) and Model B for Figure [2-50](#), Figure [2-51](#), and Figure [2-52](#).

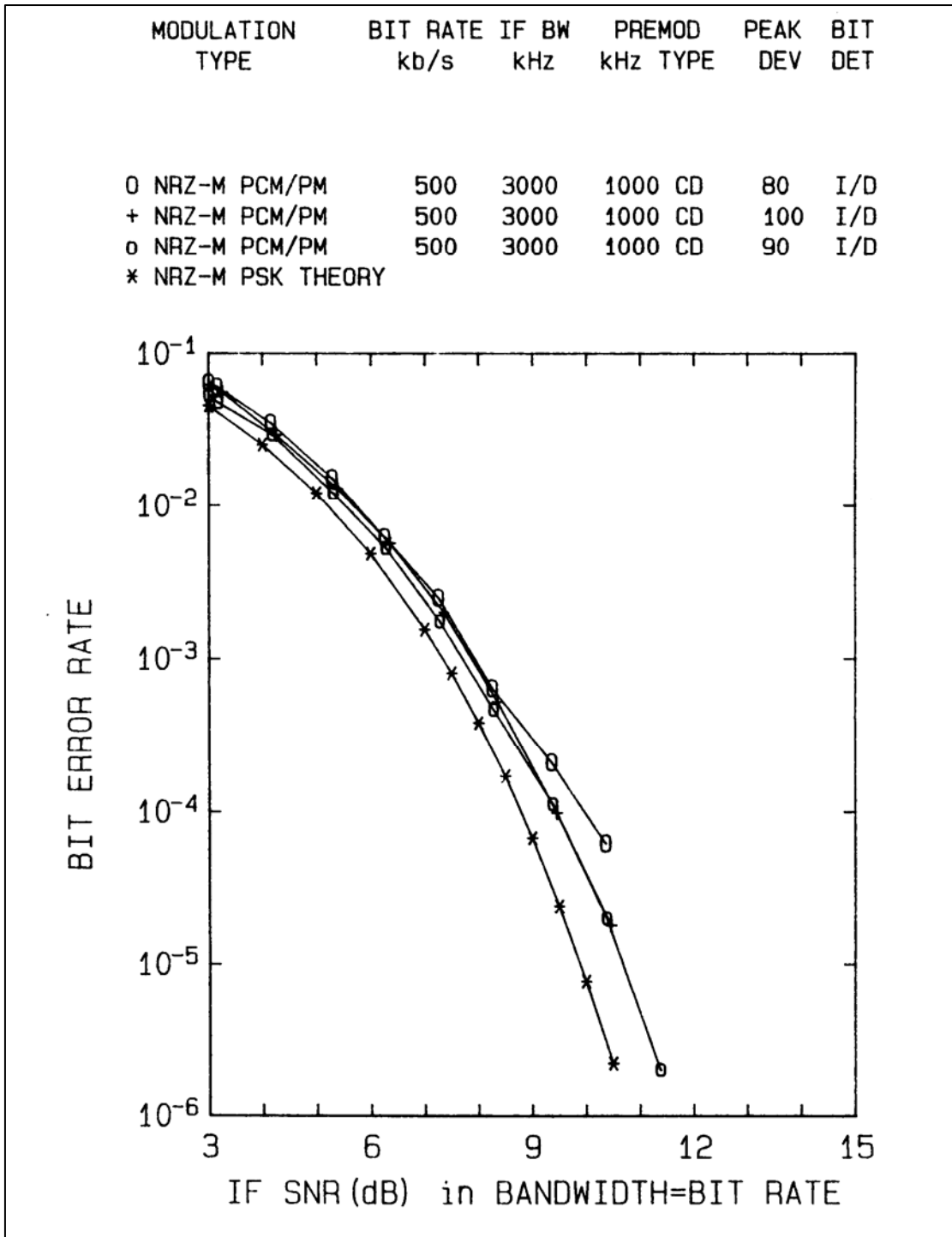

Figure 2-49. BER for peak DEV = 80, 90, and 100 degrees.

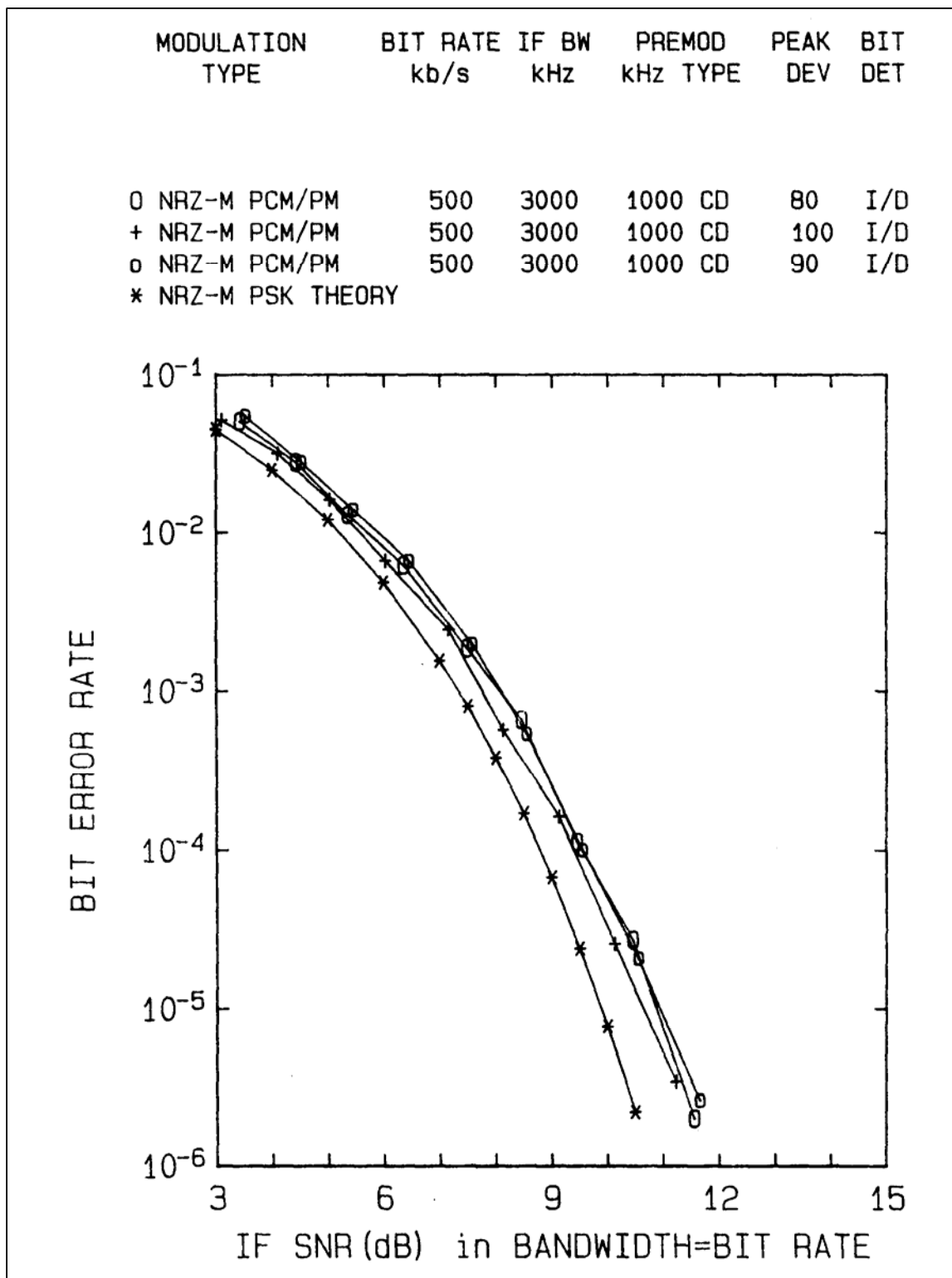

Figure 2-50. BER for peak DEC = 80, 90, and 100 degrees.

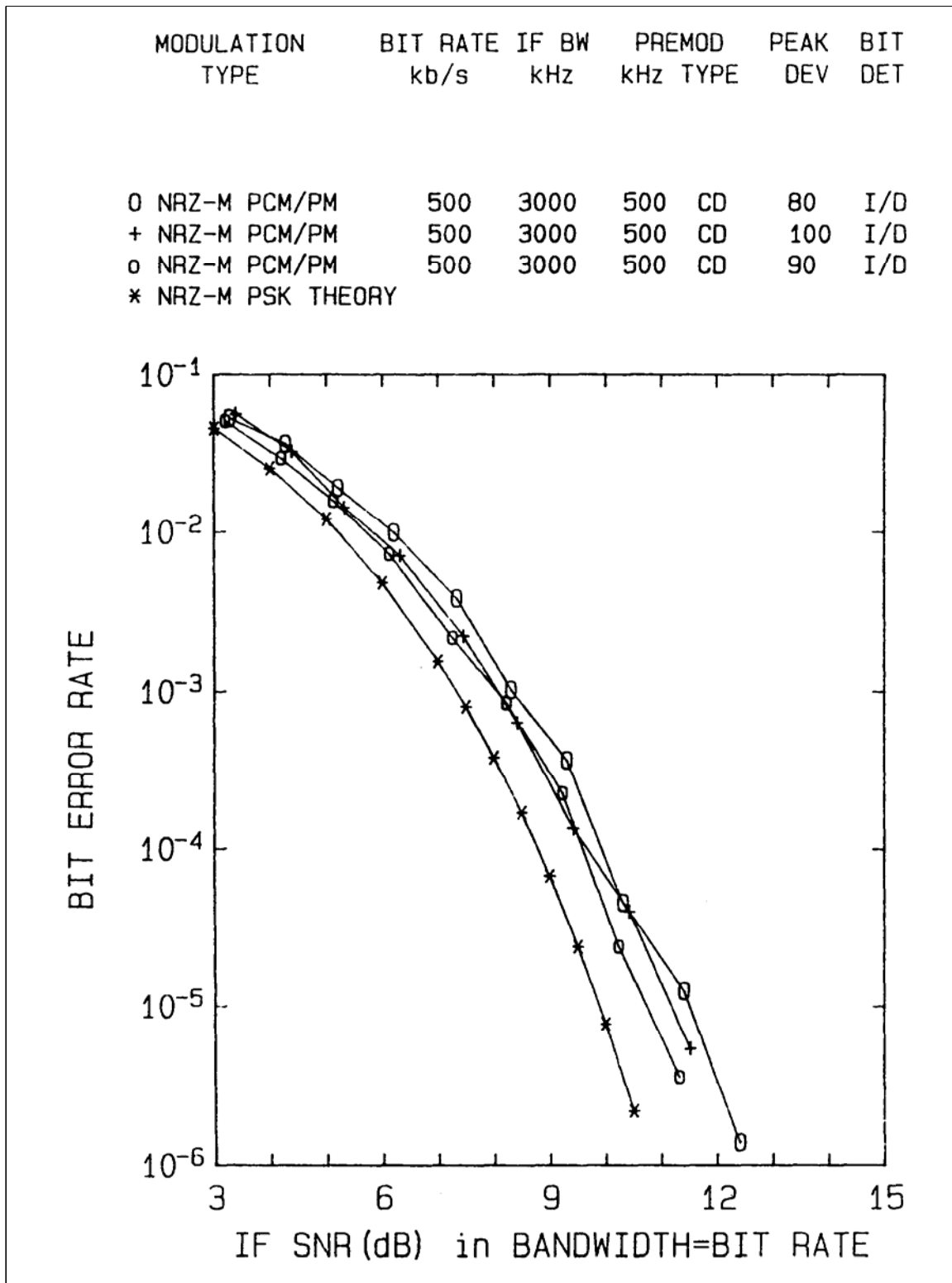
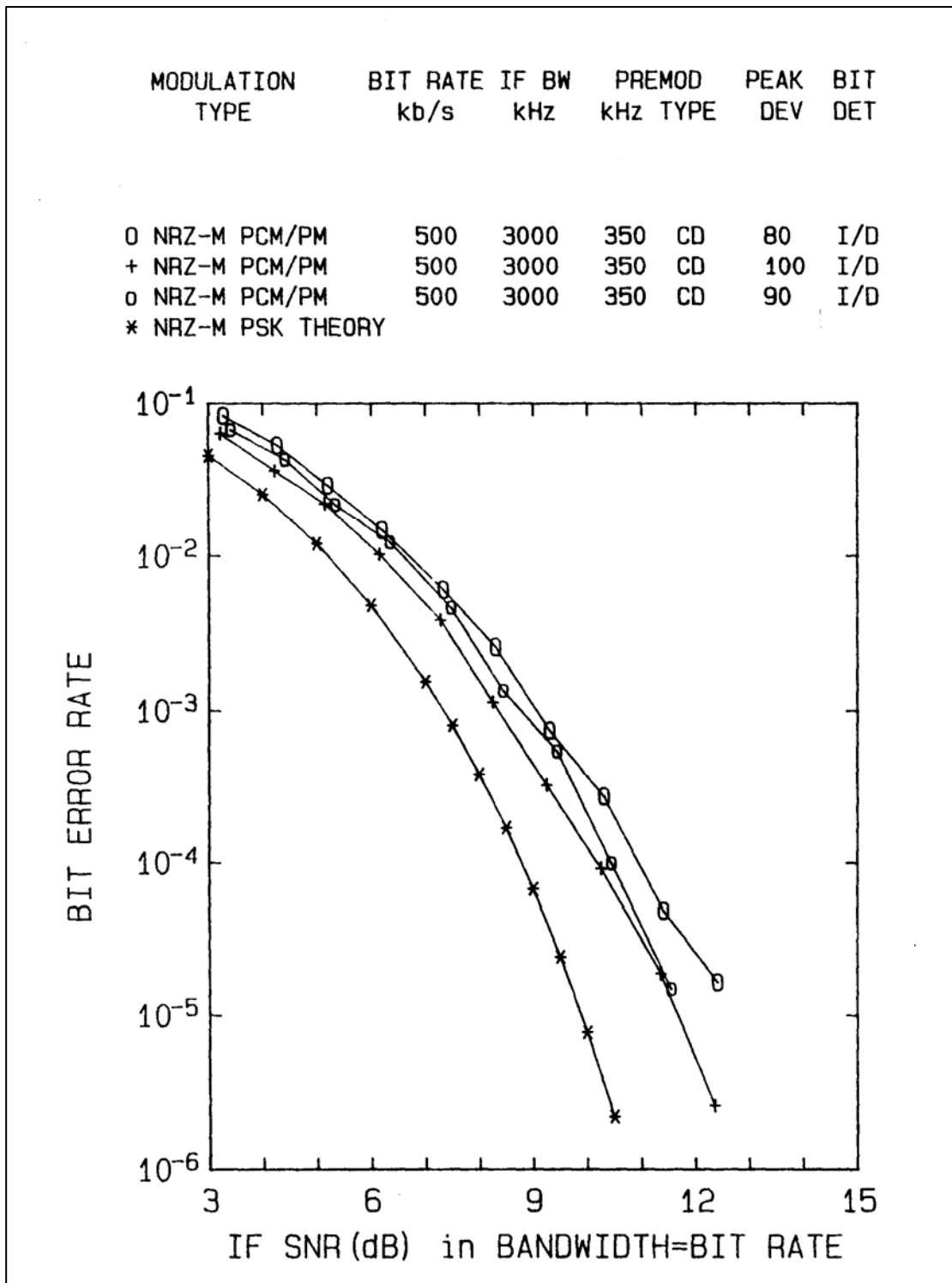

Figure 2-51. BER for PREMOD = bit rate.



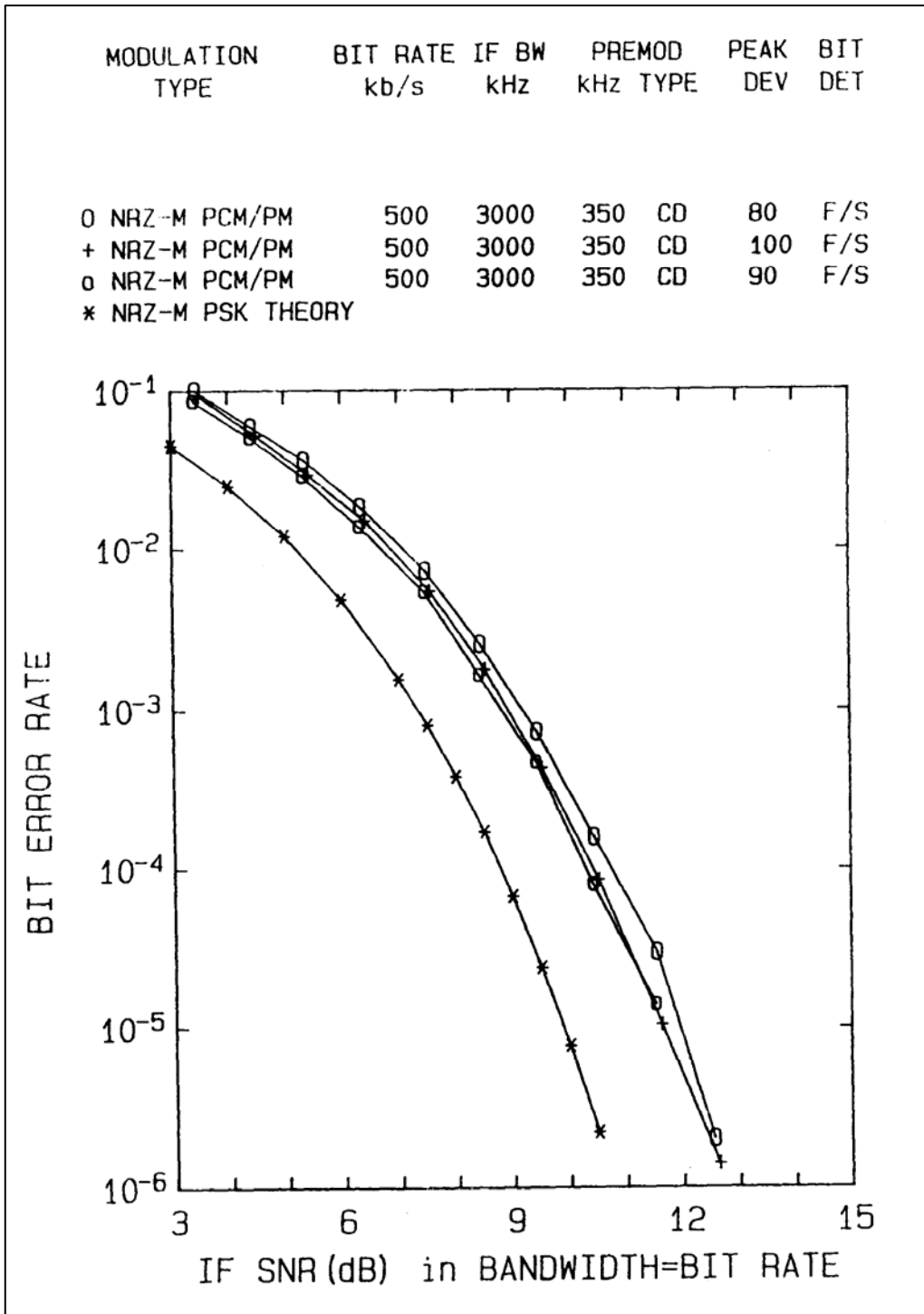

Figure 2-53. BER for PREMOD = 0.7 bit rate with F/S DET.

There is no apparent difference in the BER performance of PSK demodulator A with either 90 or 100° peak deviation. PSK demodulator B appears to have a slightly lower BER with 100° of peak deviation than with 90°. The performance with 80° of peak deviation is worse than with the other two deviations. The reason is that the premodulation filtering of the data reduces the energy in the single bits and, as a result, a higher deviation is required to make them closer to antipodal.

2.4.3 Selection of Premodulation Filter. The best classical low pass premodulation filter to use with NRZ PCM/PM (90) is a linear phase filter with the widest bandwidth, which allows the RF spectral occupancy requirements to be met. The reason for selecting a filter with the widest bandwidth is that premodulation filtering decreases the signal energy per bit without affecting the noise. The signal energy in a bit (E_b) is the integral of the signal amplitude ($S_i(t)$) squared over one bit time (T).

$$E_b = \int_0^T S_i^2(t) dt. \quad (2-4)$$

Table 2-3 presents the IF SNR in a bandwidth equal to the bit rate required to achieve a BER of 1×10^{-5} for several different premodulation filter bandwidths. The extra SNR required to achieve a BER of 1×10^{-5} , with a bit rate of 500 kb/s and a 3300-kHz IF bandwidth as compared to no premodulation filtering, is 0.5 dB with a 500-kHz linear phase premodulation filter and 1.6 dB with a 250-kHz linear phase premodulation filter. The linear phase premodulation filters cause 0.2 to 0.3 dB less degradation than the constant amplitude filters.

| TABLE 2-3. IF SNR (DB) FOR 10^{-5} BER WITH NRZ-M PCM/PM AND VARIOUS COMBINATIONS OF BIT RATE, PEAK DEVIATION, IF BANDWIDTH, AND PREMODULATION FILTER. | | | | | | |
|--|---|-------------------------------|----------------------------------|-------------|--|--|
| Bit Rate (kb/s) | Peak Deviation (Degrees) | IF Bandwidth (kHz) | Premodulation BW(kHz) | Type | IF SNR (dB) in BW=Bit Rate for 10^{-5} BER | |
| 300 | 90 | 3300 | 900 | CD | 10.7 | |
| 300 | 90 | 3300 | 300 | CD | 11.4 | |
| 500 | 90 | 3300 | | None | 10.9 | |
| 500 | 99 | 3300 | | None | 11.2 | |
| 500 | 90 | 1500 | | None | 11.1 | |
| 500 | 90 | 1000 | | None | 11.6 | |
| 500 | 90 | 3300 | 1000 | CD | 11.1 | |
| 500 | 90 | 3300 | 1000 | CA | 11.3 | |
| 500 | 90 | 3300 | 500 | CD | 11.4 | |
| 500 | 99 | 3300 | 500 | CD | 11.4 | |
| 500 | 90 | 3300 | 500 | CA | 11.7 | |
| 500 | 90 | 3300 | 250 | CD | 12.5 | |
| 500 | 107 | 3300 | 250 | CD | 12.5 | |
| 500 | 90 | 3300 | 250 | CA | 12.8 | |

2.4.4 Selection of Receiver IF Bandwidth. The best receiver IF bandwidth is the filter offering the widest bandwidth that rejects all spurious out-of-band signals. The effect of receiver IF bandwidth on BER is illustrated in Figure 2-54. The spurious signals to be rejected include telemetry signals at other center frequencies and, if the signal is to be predetection-recorded, noise that folds over and back across zero hertz when the signal plus noise is mixed with the local oscillator. An example of the second type is when using a 5-MHz IF bandwidth and a 900-kHz predetection record carrier, the noise spectrum at the -3 dB points would extend from $f_{IF} - 2.5$ MHz to $f_{IF} + 2.5$ MHz while the local oscillator frequency would typically be $f_{IF} + 0.9$ MHz. The noise at $f_0 + 1.8$ MHz would be translated to 0.9 MHz and be summed with the noise that was translated to 0.9 MHz from f_{IF} MHz. The net result would be to increase the noise power in the region around the predetection carrier frequency by approximately 3 dB; the exact amount of the increase depends upon the shape of the IF filter. The effect is the same as reducing the transmitted power by this amount. Therefore, the receiver IF bandwidth should not be wider than approximately two times the predetection carrier frequency; that is, a 1.8-MHz IF bandwidth for a 900-kHz predetection carrier. The data presented in Figure 2-55 show an approximate performance improvement of 0.4 dB when using a linear input to the PSK demodulator compared to using a limited input.

2.4.5 Selection of Demodulator Loop Bandwidth. The best loop bandwidth depends on the mission bit rate and the bandwidth of the incidental phase modulation. The loop bandwidth should be wide enough to track out any large amplitude incidental phase modulation. One wideband source of phase modulation is transmission through an ionized gas cloud (plasma). Various rocket booster motors produce ionized gas clouds that cause incidental phase modulation with bandwidths of several kilohertz. However, if the loop bandwidth is wider than approximately 5 percent of the bit rate, the BER with no incidental phase modulation starts to increase.

2.4.6 Selection of Demodulator Video Bandwidth. The best demodulator video bandwidth is largely determined by the bit detector used (see Figure 2-56). The premodulation filter bandwidth was 1000 kHz for the data in Figure 2-56. The lowest BER was obtained using an integrate and dump bit detector and the widest video filter. The highest BER occurred when a video filter of one-half the bit rate was used in conjunction with the integrate and dump bit detector. The difference in performance was approximately 2 dB at a 10^{-5} BER. When a filter and sample (F/S) bit detector was selected, the highest BER occurred with the widest video filter. The lowest bit error rates with the F/S bit detector were achieved with video filters equal to one-half of the bit rate and the bit rate. The reason for the better F/S performance with narrower filters in Figure 2-56 is that the F/S bit detector is a matched filter for signals filtered at approximately 0.75 times the bit rate. Using a filter that is narrower than one-half the bit rate will cause the performance to degrade rapidly.

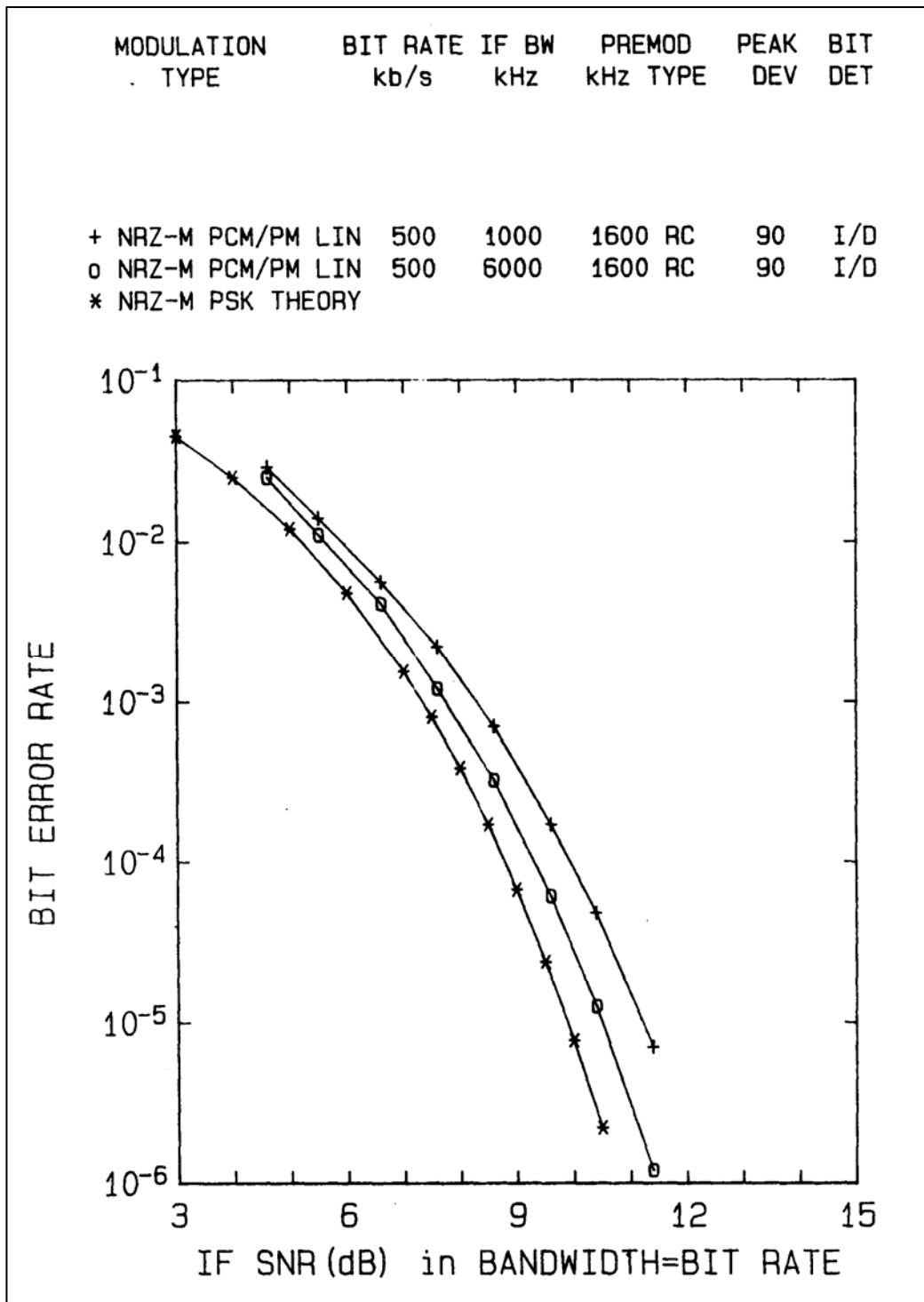

Figure 2-54. BER for IF BW/bit rate = 2 and 12.

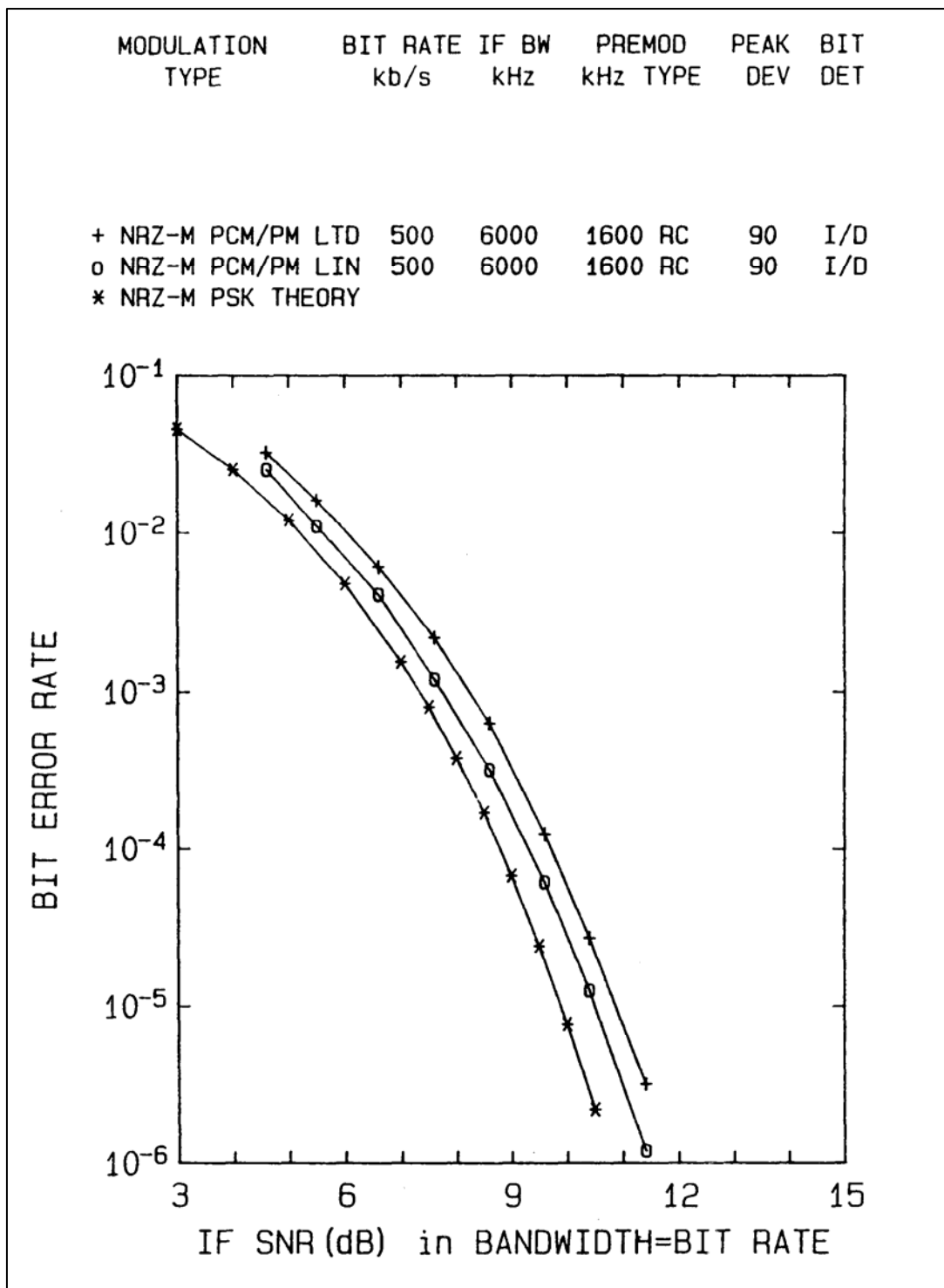

Figure 2-55. BER for linear and limited IF signals.

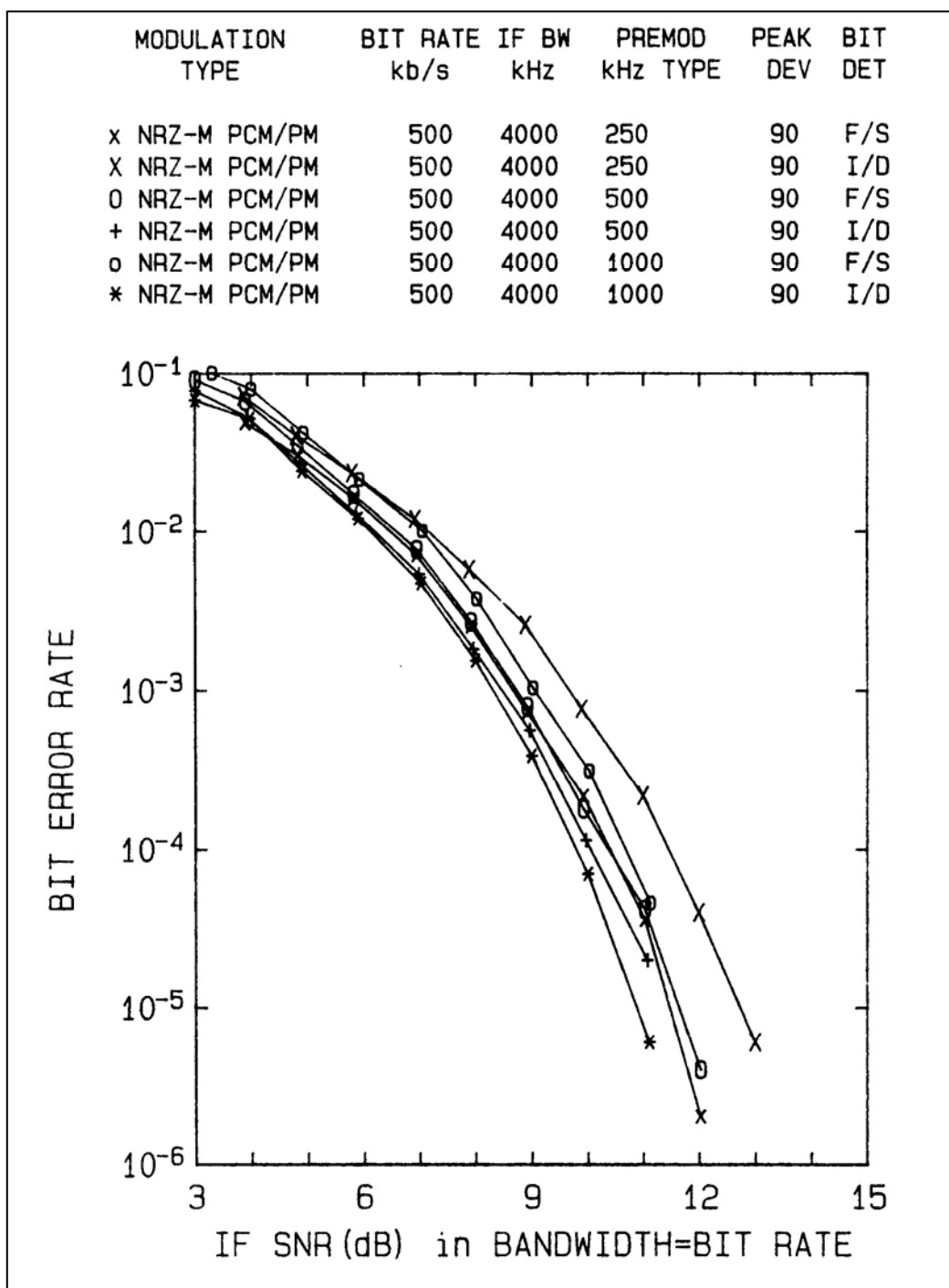

Figure 2-56. BER for video BW/BIT rate = 0.5, 1, and 2.

2.4.7 Selection of PCM Bit Synchronizer Bit Detector. The best PCM bit synchronizer bit detector when using NRZ PCM/PM (90) depends on the amount of filtering performed on the signal prior to the bit synchronizer. When the premodulation and video filter are wider than a value corresponding to the bit rate and the IF bandwidth is set to a value which is equal to at least twice the data bit rate, then the integrate and dump (I/D) bit detector will probably provide the lower bit error rate. When the bandwidth of the premodulation and/or video filters are narrower than 0.7 times the data bit rate and/or the IF bandwidth is less than 1.4 times the bit rate, the filter and sample (F/S) bit detector will probably provide the lower bit error rate. If the total filtering is between the values previously stated, then the I/D bit detector is probably the better choice. This is illustrated in Figure [2-56](#). When the narrowest filter is twice the bit rate, the I/D detector performs approximately 1 dB better than the F/S detector at BERs between 10^{-4} and 10^{-5} . When the narrowest filter is one-half the bit rate, the F/S detector performs approximately 1 dB better than the I/D detector.

2.4.8 RF Spectra and Carrier Level. The optimum peak deviation for unfiltered NRZ PCM/PM is 90° . This deviation produces a carrier null (see Figure 2-57, Figure 2-58, and Figure 2-59). As the bit rate is increased from 50 kb/s to 500 kb/s and 800 kb/s, the depth of the carrier null decreases and discrete frequency components appear in the spectrum. These components are caused by the finite rise and fall times of the PCM bit stream and the finite bandwidth of the phase modulator in the RF generator. When a premodulation filter is used, a peak deviation of 90° will no longer produce a carrier null (refer to Figure 2-60). The peak deviation required to produce a carrier null depends on the premodulation filter bandwidth, the filter type and number of poles, as well as the bit pattern of the PCM data. When using a 2047-bit pseudo-noise bit stream at 800 kb/s and an 800-kHz 5-pole linear phase premodulation filter, the minimum carrier level occurs at a peak deviation of 99° (refer to Figure 2-61). A different peak deviation produces the minimum carrier level for other bit patterns for this bit rate and filter. For example, with a bit pattern containing all ones and an NRZ-M code, the carrier is only suppressed 10.6 dB for a peak deviation of 90° (refer to Figure 2-62), but is suppressed by 30.4 dB for a peak deviation of 111° (refer to Figure 2-63). This is the maximum suppression for any deviation under the conditions stated above. However, when the bit pattern is changed to a 2047-bit pseudo-noise sequence, the carrier is only suppressed by 11 dB for a peak deviation of 111° (refer to Figure 2-64). The attenuation of 11 dB is less than the 11.4 dB of carrier suppression produced for a peak deviation of 90° under these conditions. With a 400-kHz 5-pole linear phase premodulation filter, the carrier is suppressed 8.6 dB (refer to Figure 2-65) for a peak deviation of 90° with a 2047-bit pseudo-noise sequence. The minimum carrier level occurs with a peak deviation of 113° under the above conditions (refer to Figure 2-66). Figure 2-67 and Figure 2-68 show the RF spectra with constant amplitude premodulation filters. The occupied bandwidth of 800 kb/s NRZ-M PCM/PM is determined by the spectral spikes and is equal to eight, six, and four times the bit rate for premodulation filters of 800 kHz CD, 800 kHz CA, and 400 kHz CD respectively.

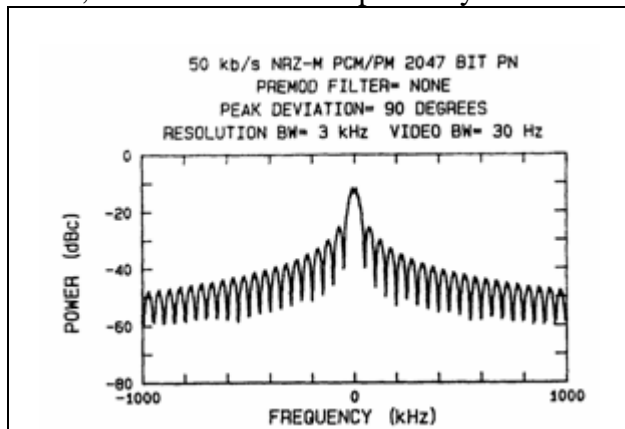

Figure 2-57. RF spectrum 50 kb/s NRZ-M PCM/PM.

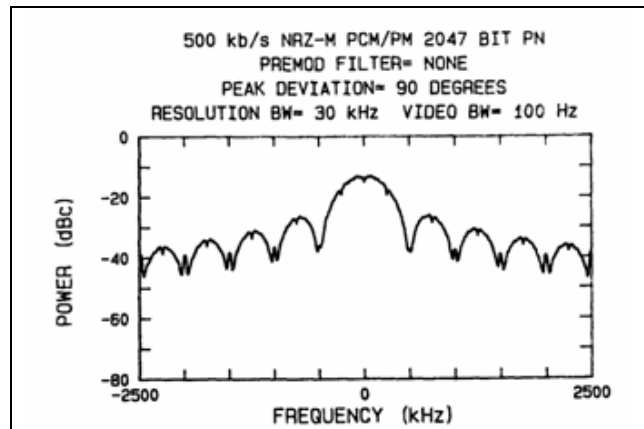

Figure 2-58. RF spectrum 500 kb/s NRZ-M PCM/PM.

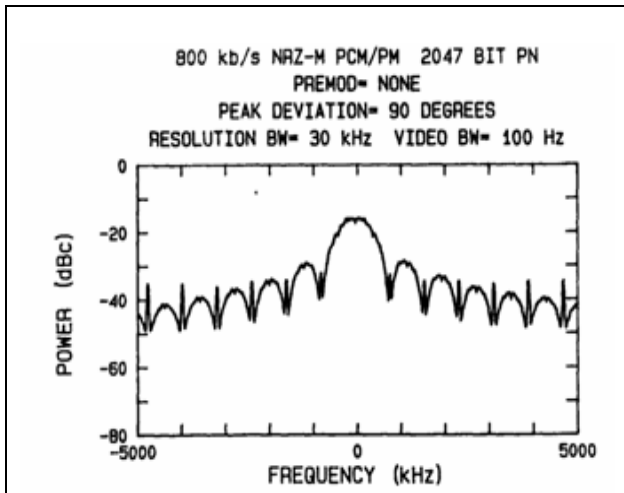

Figure 2-59. RF spectrum 800 kb/s NRZ-N PCM/PM.

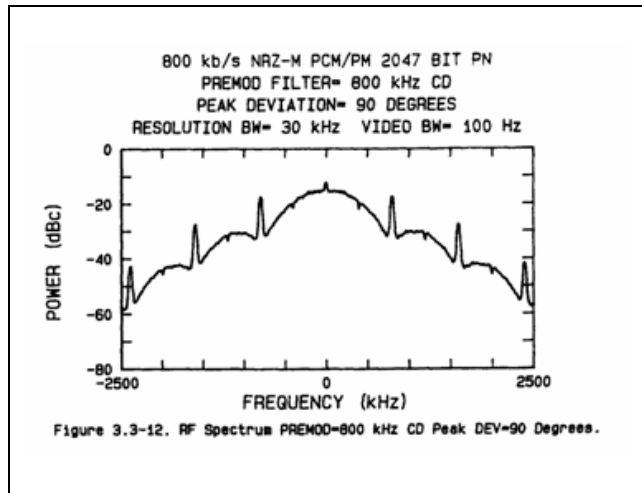

Figure 2-60. RF spectrum PREMOD = 800 kHz CD peak DEV = 0.90 degrees.

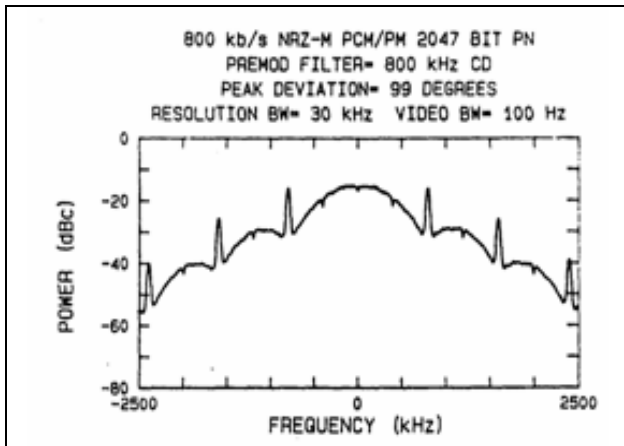

Figure 2-61. RF spectrum PREMOD = 800 kHz CD peak DEV = 99 degrees.

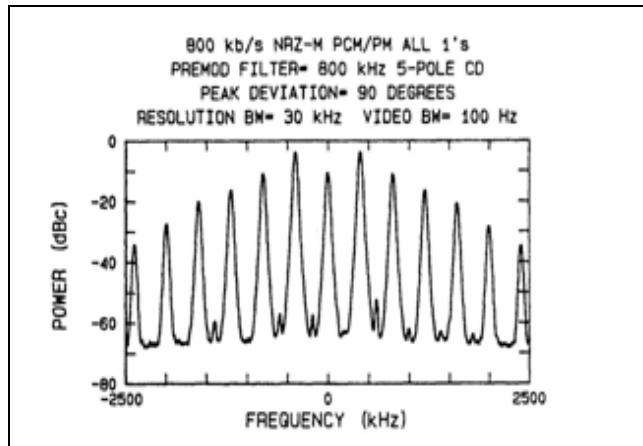

Figure 2-62. RF spectrum PREMOD = 800 kHz CD peak DEV = 90 degrees (1s).

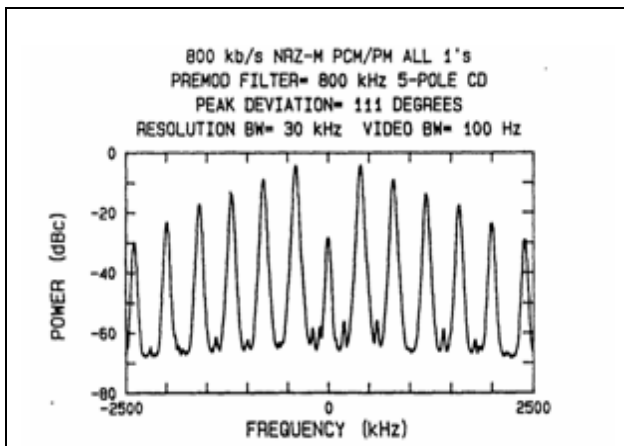

Figure 2-63. RF spectrum PREMOD = 800 kHz CD peak DEV = 111 degrees (1s).

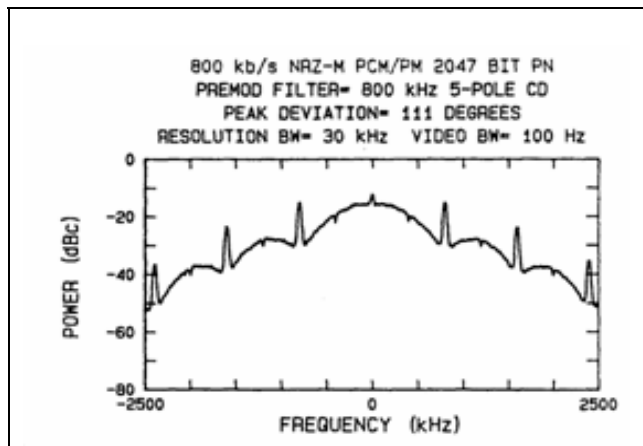

Figure 2-64. RF spectrum PREMOD = 800 kHz CD peak DEV = 111 degrees.

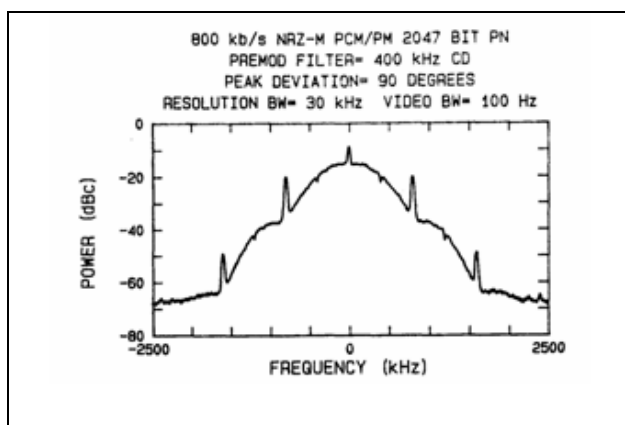

Figure 2-65. RF spectrum PREMOD = 400 kHz CD peak DEV = 90 degrees.

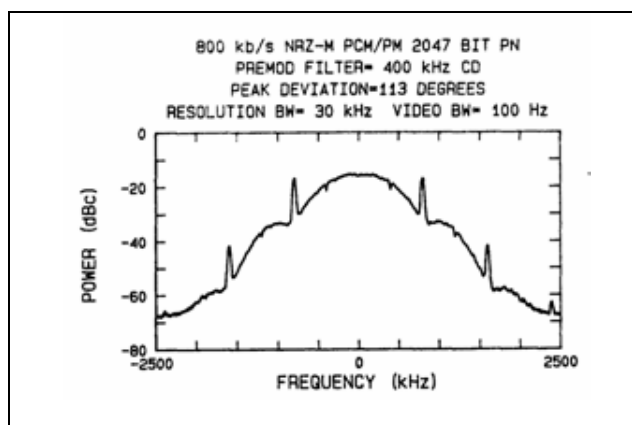

Figure 2-66. RF spectrum PREMOD = 400 kHz CD peak DEV = 113 degrees.

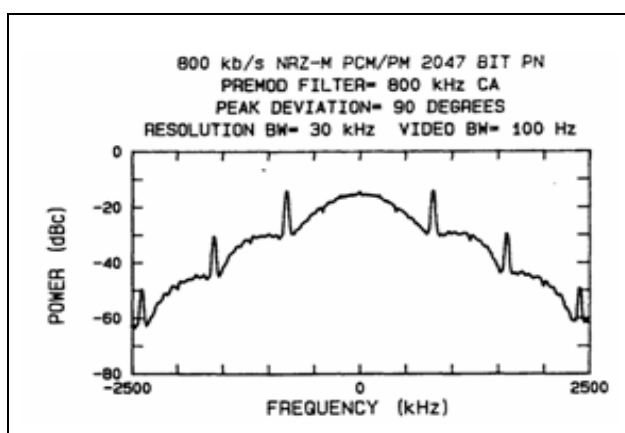

Figure 2-67. RF spectrum PREMOD = 800 kHz CA peak DEV = 90 degrees.

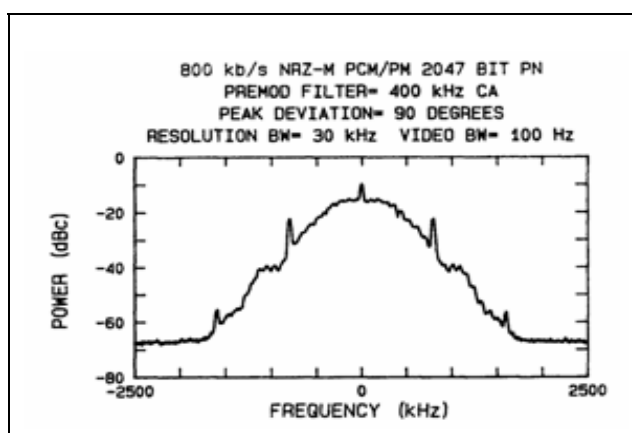

Figure 2-68. RF spectrum PREMOD = 400 kHz CA peak DEV = 90 degrees.

2.5 Biphase PCM/PM

2.5.1 Introduction. There are two major types of biphase PCM/PM telemetry signals:

- a. Signals with a peak deviation less than 90°
- b. Signals with a peak deviation of approximately 90°

If the peak deviation is less than 90° , a signal component is always present at the unmodulated carrier frequency. The percentage of the total power contained in this component is determined by the peak deviation, premodulation filtering, phase modulator bandwidth, and the PCM signal bit pattern. If there is no filtering, the remnant carrier power is proportional to $\cos^2(\Delta\theta)$ and the demodulator output signal power is proportional to $\sin^2(\Delta\theta)$ where $\Delta\theta$ is the peak deviation. Therefore, the use of a peak deviation of 60° results in a signal power loss of at least 1.25 dB compared to the use of a 90° peak deviation. The signal loss for a 75° peak deviation is only 0.3 dB with no filtering.

If there is sufficient carrier power present, a phase-locked loop (PLL) can be used to track the carrier component and to provide a reference signal to the phase demodulator. As the percentage of the total power remaining in the carrier is increased, the demodulated signal amplitude will be reduced proportionately. However, if the carrier component is too small, the PLL will not be able to maintain accurate phase lock at low SNRs. Consequently, a trade-off must be made between carrier power and signal power. Peak carrier deviations between 60° and 75° are usually used for biphase PCM/PM with a carrier-tracking phase demodulator. However, if a premodulation filter bandwidth of twice the bit rate or less is used, peak deviations of 90° can be used successfully with a carrier-tracking demodulator. The carrier is attenuated by approximately 12 dB with a linear phase premodulation filter at twice the bit rate and a peak deviation of 90° (see Figure 2-69). If a peak deviation of 90° is used with a carrier-tracking demodulator, the system designer must make sure that the actual peak deviation cannot produce a carrier null under worst-case combinations of deviation sensitivity and bit stream amplitude.

When a peak deviation of approximately 90° is used, a PSK demodulator can be used to demodulate the signal with or without a carrier null. A PSK demodulator reconstructs a carrier signal and uses this signal to coherently detect the modulation. The two most common types of PSK demodulators use a Costas loop or a squaring loop to reconstruct the carrier signal. Both techniques have a 180° phase ambiguity problem, which means that the polarity (inverted or normal) of the detected signal is unknown. If carrier lock is lost, the detected signal, after lock is reacquired, has a 50 percent chance of being inverted compared to the signal before carrier lock was lost. Consequently, the mark and space versions of biphase are usually used when a PSK demodulator is used. The carrier-tracking demodulator does not have a polarity reversal problem and therefore biphase level is usually used in biphase PCM/PM systems when sufficient carrier level is present to allow the demodulator to track the carrier. The bit error rate for biphase level is approximately one-half of the bit error rate for biphase mark and biphase space.

2.5.2 Selection of Peak Deviation. Bit error rate data is presented in Figure 2-70 for peak deviations of 60° , 75° , and 90° . The bit rate was 500 kb/s, the IF bandwidth was 4000 kHz, and a 1000-kHz 5-pole constant delay premodulation filter was used. This data shows that a 75° peak deviation performed about 1.2 dB better than a 60° peak deviation under these test conditions. This difference is slightly larger than the 0.95 dB predicted for non-filtered data. The additional degradation is because the premodulation filtering reduces the effective amplitude per bit. This reduction decreases the effective deviation, which causes a reduction in $\sin^2(\Delta\theta)$. The reduction in \sin^2 is larger for small $\Delta\theta$ than for large $\Delta\theta$ with the same proportional reduction in $\Delta\theta$.

Comparing biphase level PCM/PM with peak deviations of 75° and 90° , we find that a peak deviation of 90° performs 0.3 to 0.4 dB better than a peak deviation of 75° . The carrier level was -12 dBc with a 90° peak deviation and -7 dBc with a 75° peak deviation. Thus, carrier lock will be lost 5 dB sooner with a 90° peak deviation than with a 75° peak deviation. However under these test conditions, the PCM bit synchronizer (loop bandwidth of 0.3 percent) lost lock before a PM demodulator with a 1-kHz loop bandwidth did. A Costas loop demodulator provided the same BER performance as the PM demodulator, but the unknown polarity when using biphase level would present a problem for many applications. Switching to

biphase mark causes the BER to approximately double. This is equivalent to a 0.3-dB penalty at a 10^{-5} BER, a 0.5-dB penalty at a 10^{-3} BER, a 0.9-dB penalty at a 10^{-2} BER, and a 2-dB penalty at a BER of 10^{-1} . Consequently, biphase mark with a 90° peak deviation should perform much the same as biphase level with a 75° peak deviation at a BER of 10^{-5} . This is also shown in Figure 2-70 Biphase level with a 75° peak deviation has a measurably lower BER than biphase mark with a 90° peak deviation for BERs larger than 10^{-3} .

Bit error rate data is presented in Figure 2-71 for a premodulation filter equal to the bit rate and peak deviations of 60° , 75° , and 90° . Again, a peak deviation of 75° performs approximately 1.2 dB better than a deviation of 60° . However, under these conditions, a 90° peak deviation and biphase level coding perform approximately 1 dB better than a 75° peak deviation at a BER of 10^{-5} . A 90° peak deviation and biphase mark coding perform better than a 75° peak deviation and biphase level coding for BERs less than 10^{-2} .

2.5.3 Selection of Premodulation Filter. The data presented in Figure 2-72 through Figure 2-75 show that the bit error performance is essentially the same for constant amplitude and constant delay filters having the same bandwidth. These data also show that the BER penalty for using a premodulation filter with a bandwidth equal to the bit rate instead of a premodulation filter equal to twice the bit rate is 1.5 ± 0.5 dB when the IF bandwidth is at least three times the bit rate. The penalty is approximately 1.8 dB with a 60° peak deviation, 1.5 dB with a 75° peak deviation, and 1.0 dB with a 90° peak deviation for an IF bandwidth of eight times the bit rate. With an IF bandwidth equal to twice the bit rate, the penalty for using a premodulation bandwidth equal to the bit rate is 1.2 ± 0.2 dB. The penalty for using a premodulation filter equal to twice the bit rate is approximately 0.3 dB when compared to no premodulation filtering.

Figure 2-76 shows a biphase level PCM signal that has been low-pass filtered at twice the bit rate. Figure 2-77 shows a biphase level PCM eye pattern with a low pass filter at 1.4 times the bit rate.

2.5.4 Selection of Receiver IF Bandwidth. The effect of different IF filter bandwidths on the bit error rate is shown in Figure 2-78, Figure 2-79, and Figure 2-80. These data show that an IF bandwidth of eight times the bit rate performs approximately the same as an IF bandwidth of twenty times the bit rate. An IF bandwidth of three times the bit rate causes an SNR penalty of approximately 0.5 dB when compared to an IF bandwidth of eight times the bit rate. An IF bandwidth of two times the bit rate causes an SNR penalty of approximately 1.3 dB when compared to an IF bandwidth of eight times the bit rate.

2.5.5 Selection of Demodulator Loop Bandwidth. The best loop bandwidth is a function of the mission bit rate and the bandwidth of the incidental phase modulation. The loop bandwidth should be wide enough to track out any large amplitude incidental phase modulation. The BER with no incidental phase modulation starts to increase if the loop bandwidth is wider than approximately 2 percent of the bit rate for a PM demodulator and 5 percent of the bit rate for a PSK demodulator.

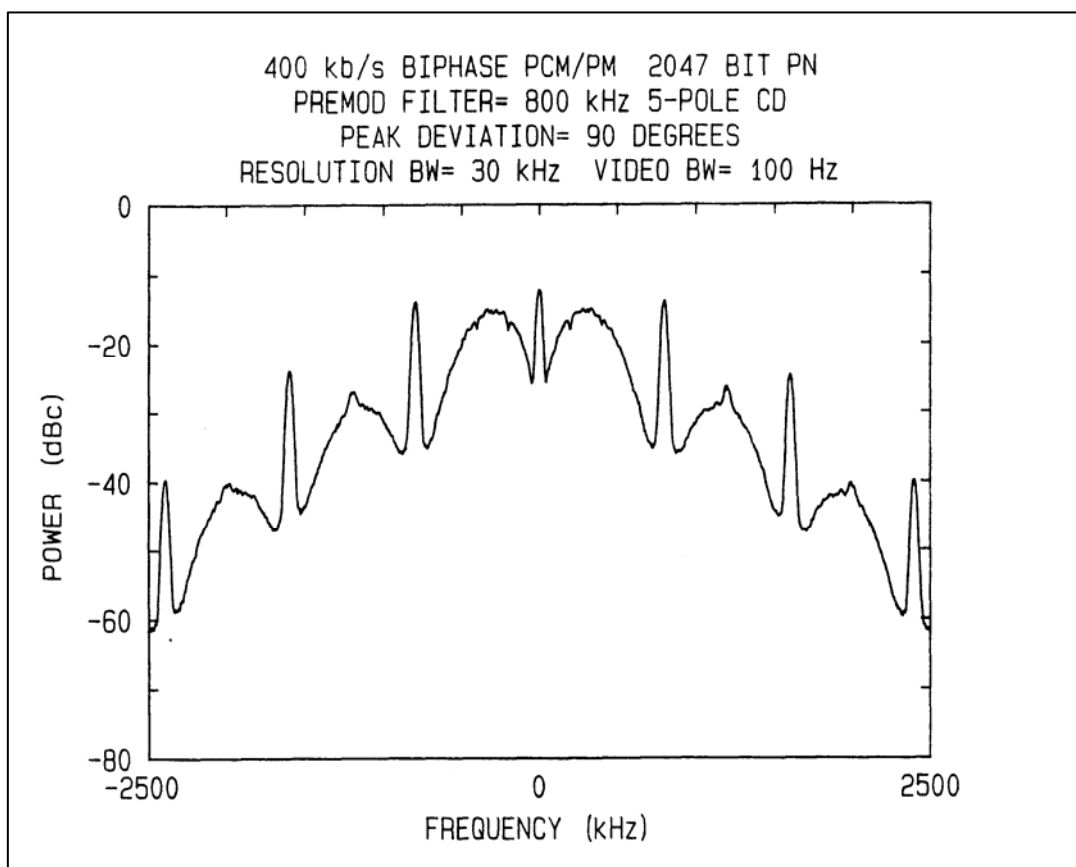

Figure 2-69. 400 kb/s biphase PCM/PM RF spectrum (PREMOD = 800 kHz CD, DEV = 90 degrees).

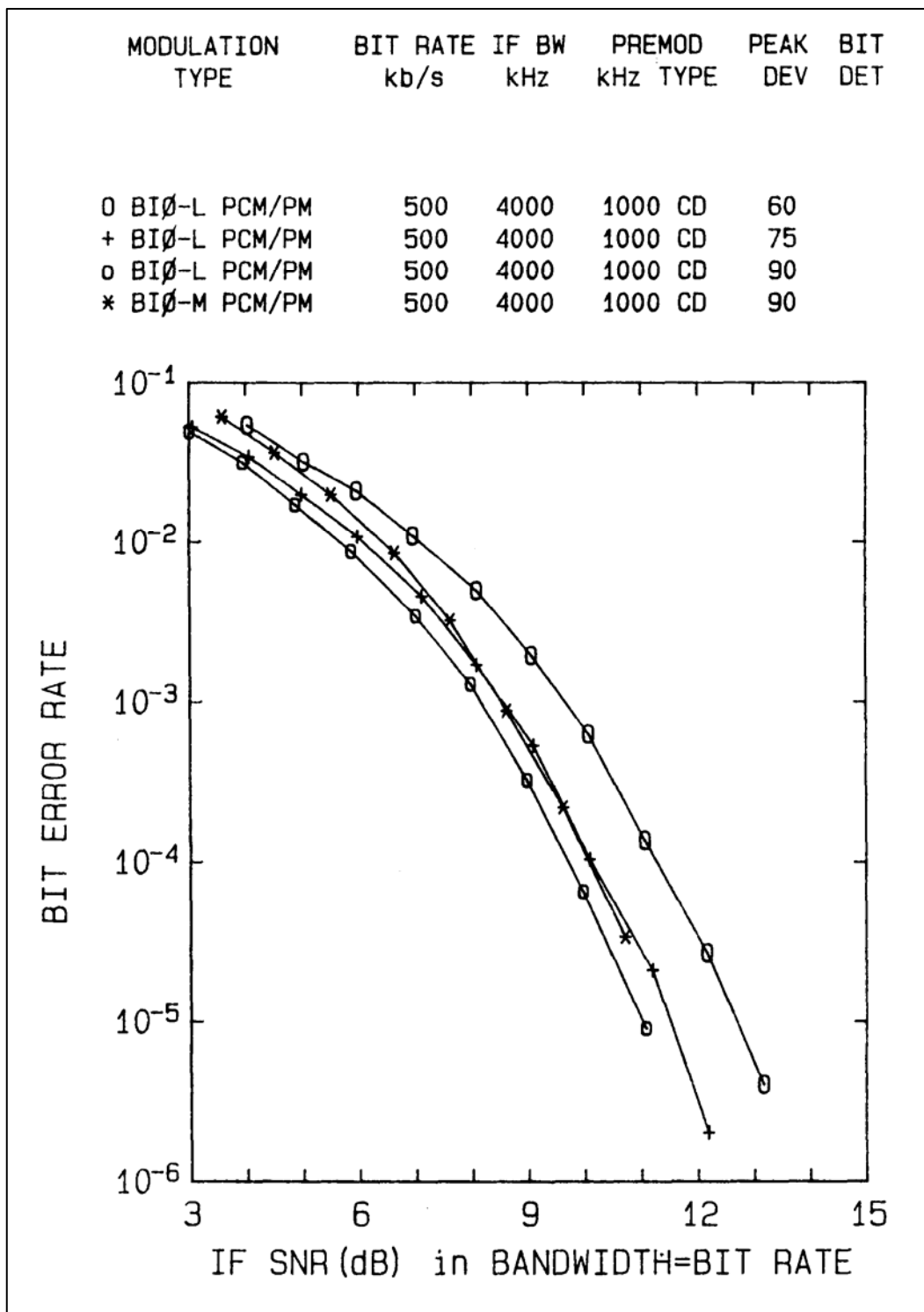

Figure 2-70. BER for peak DEV = 60, 75, and 90 degrees.

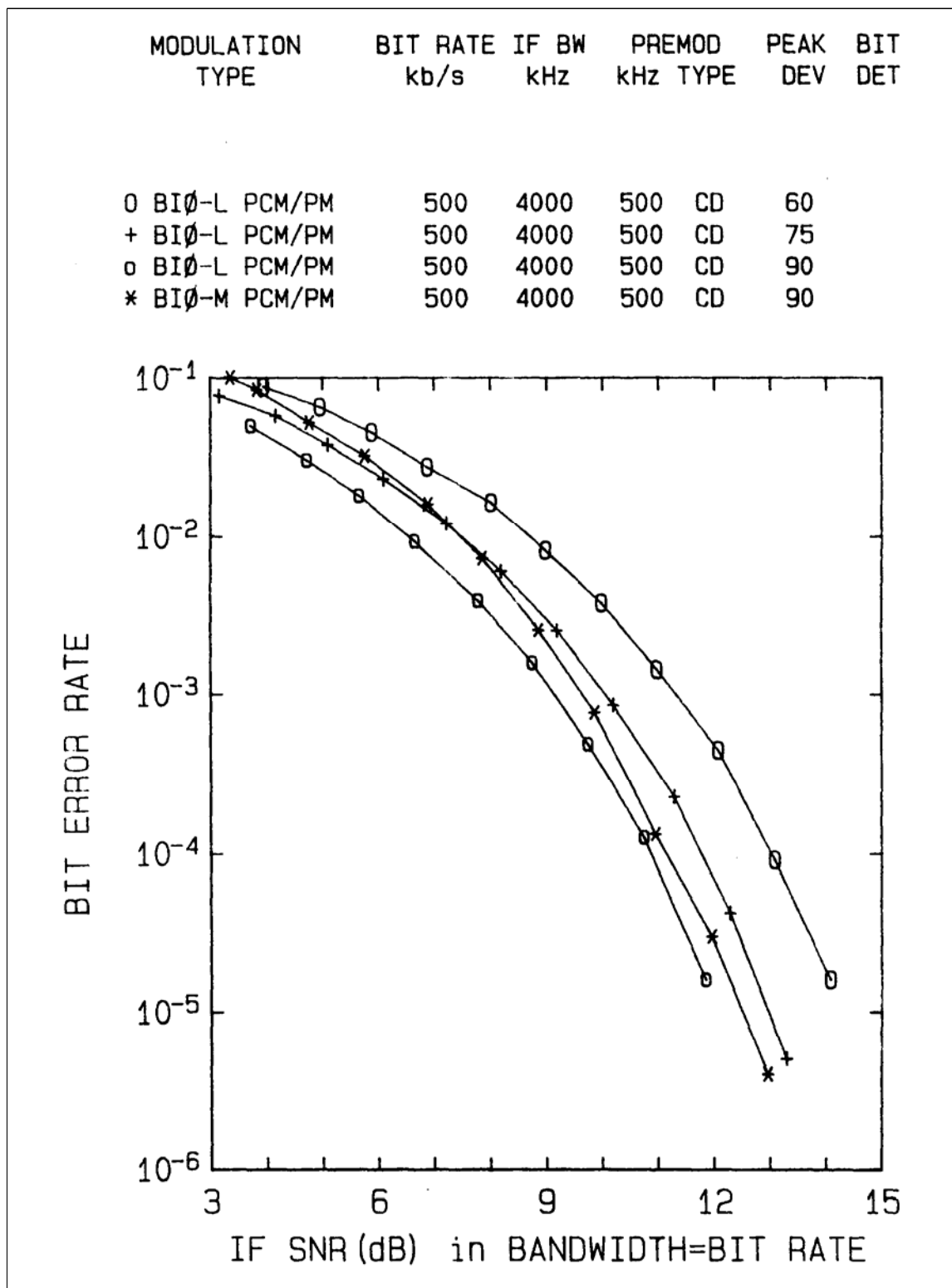

Figure 2-71. BER for peak DEV = 60, 75, and 90 degrees.

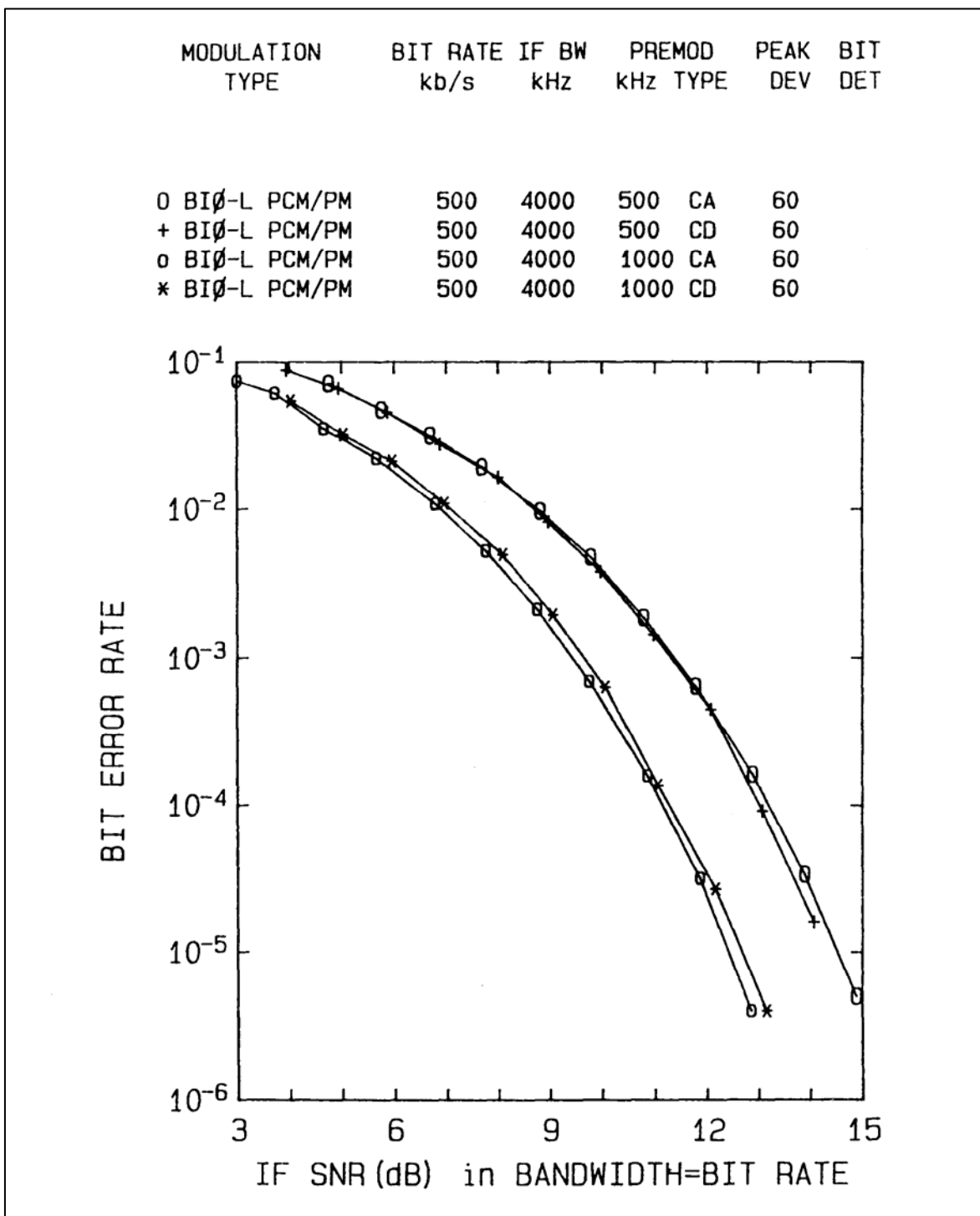

Figure 2-72. BER for peak DEV = 60 DEG and PREMOD = 1 and 2 bit rate.

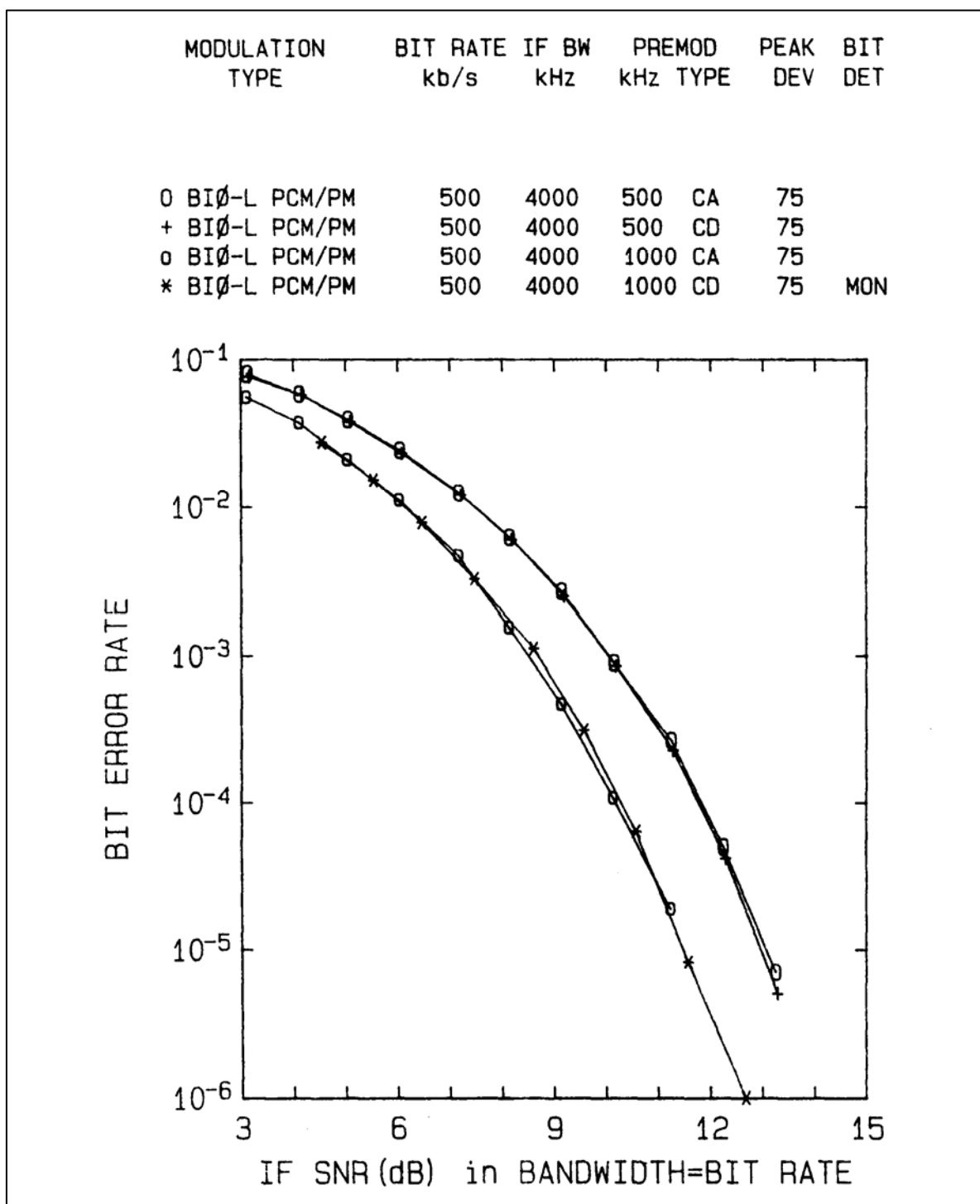

Figure 2-73. BER for peak DEV = 75 DEG and PREMOD = 1 and 2 bit rate.

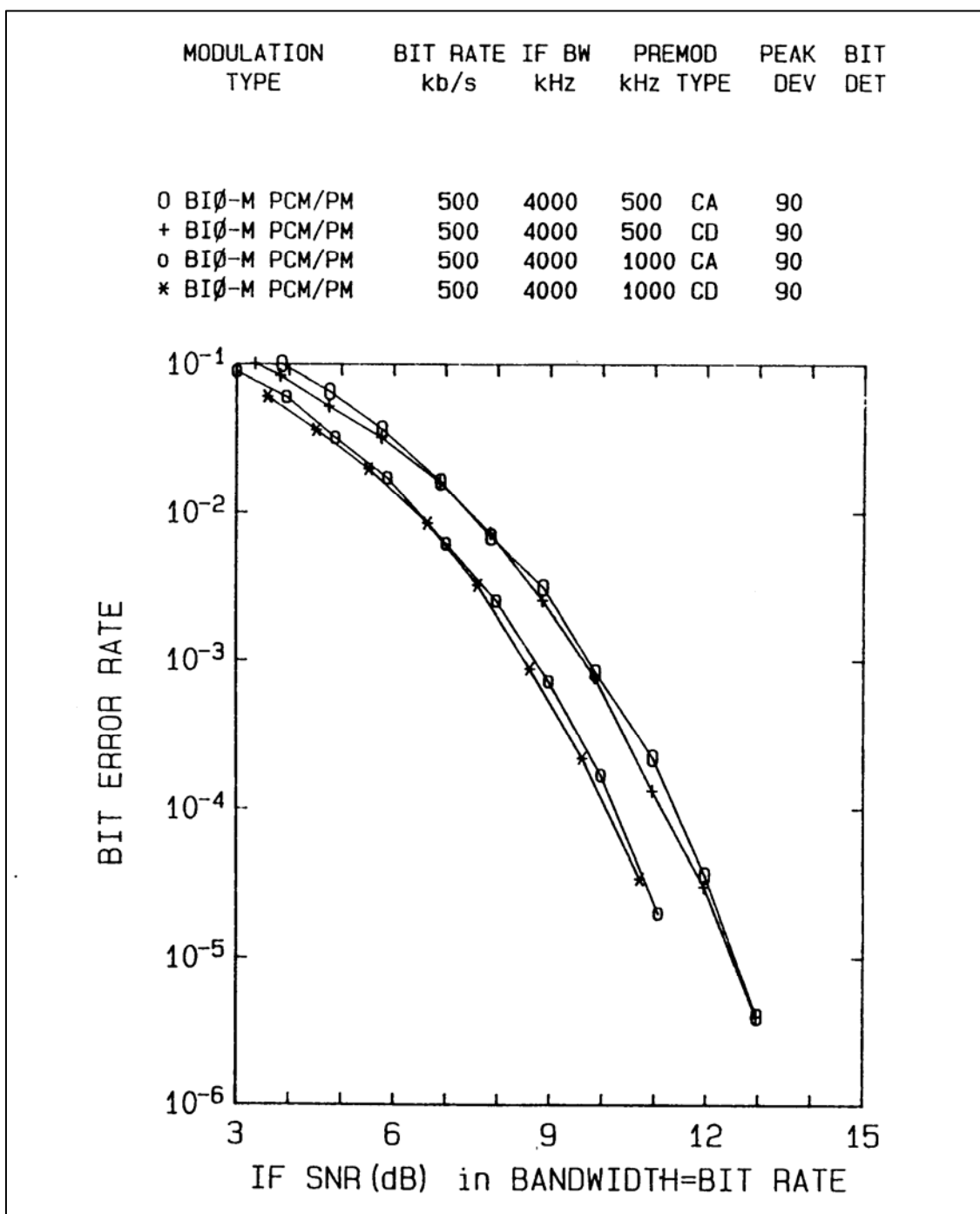

Figure 2-74. BER for peak DEV = 90 DEG and PREMOD = 1 and 2 bit rate.

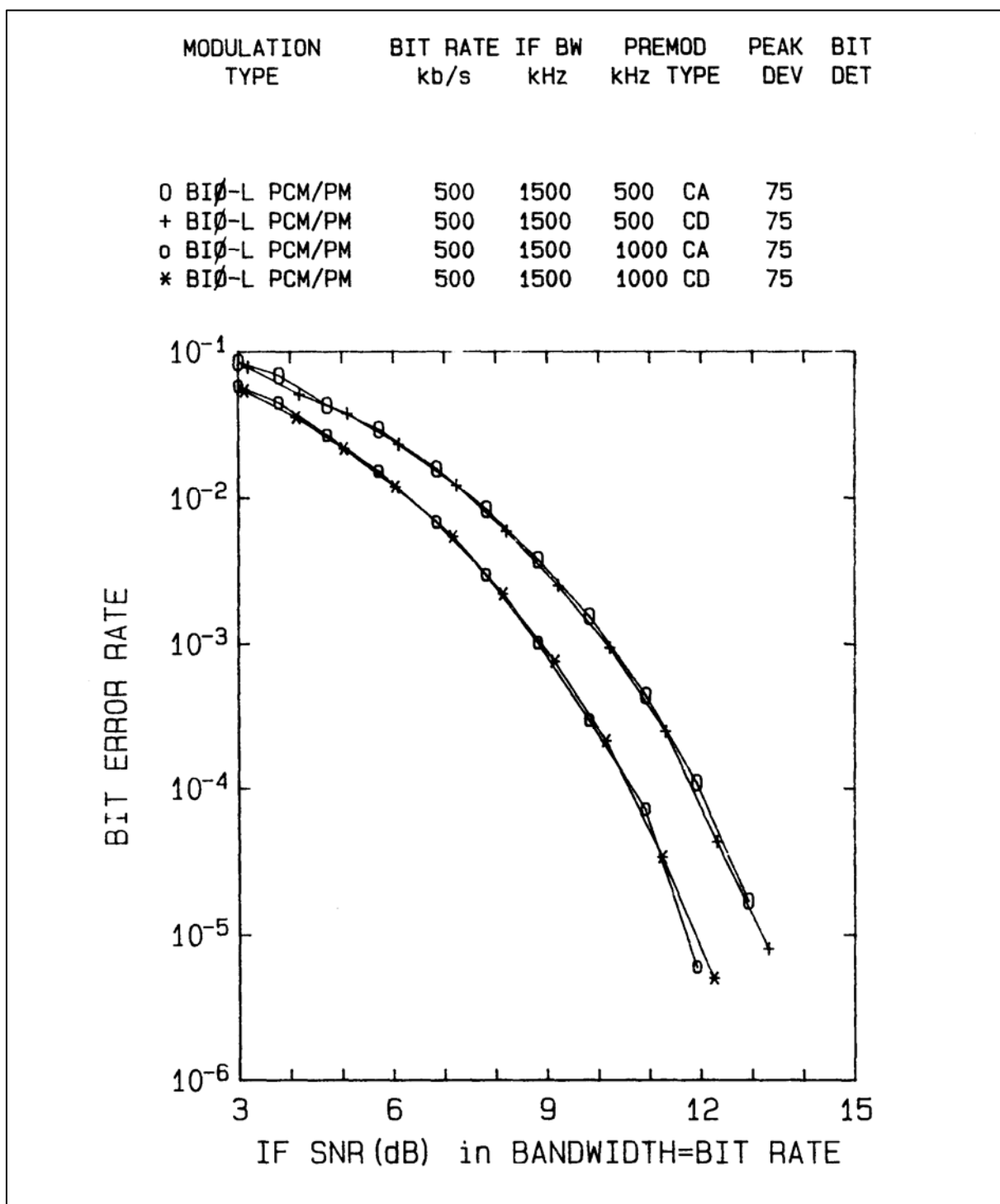

Figure 2-75. BER for IF BW=3 bit rate and PREMOD = 1 and 2 bit rate.

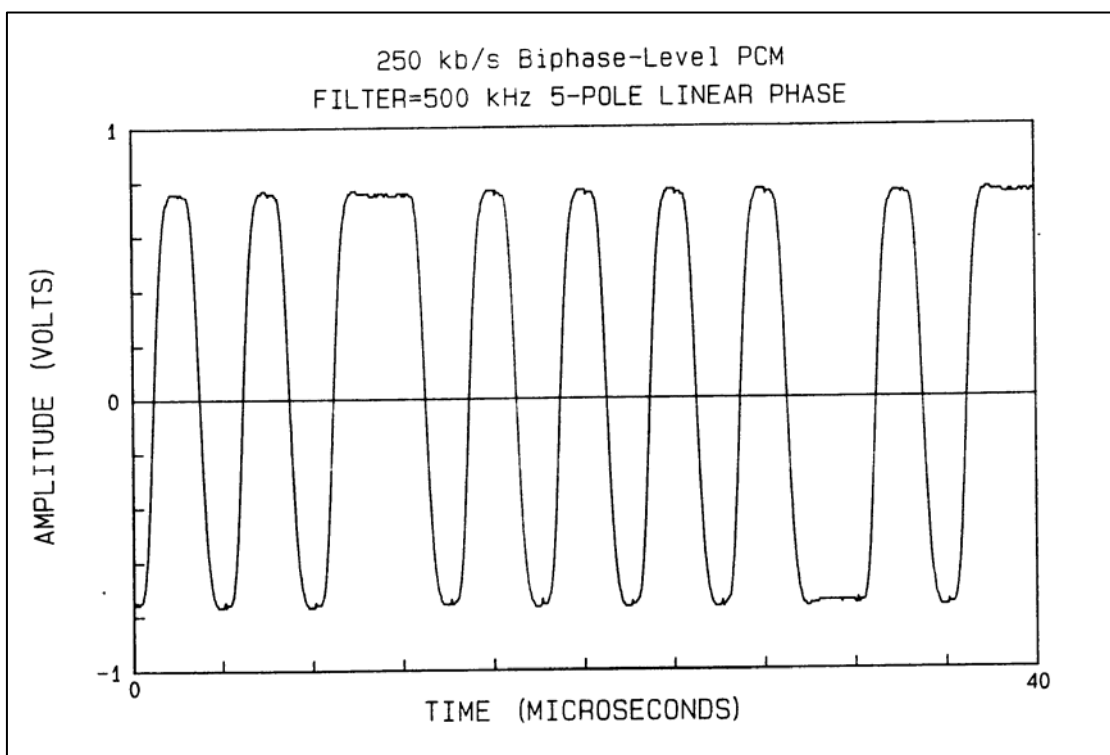

Figure 2-76. Biphas Signal with PREMOD BW = 2 times bit rate (CD).

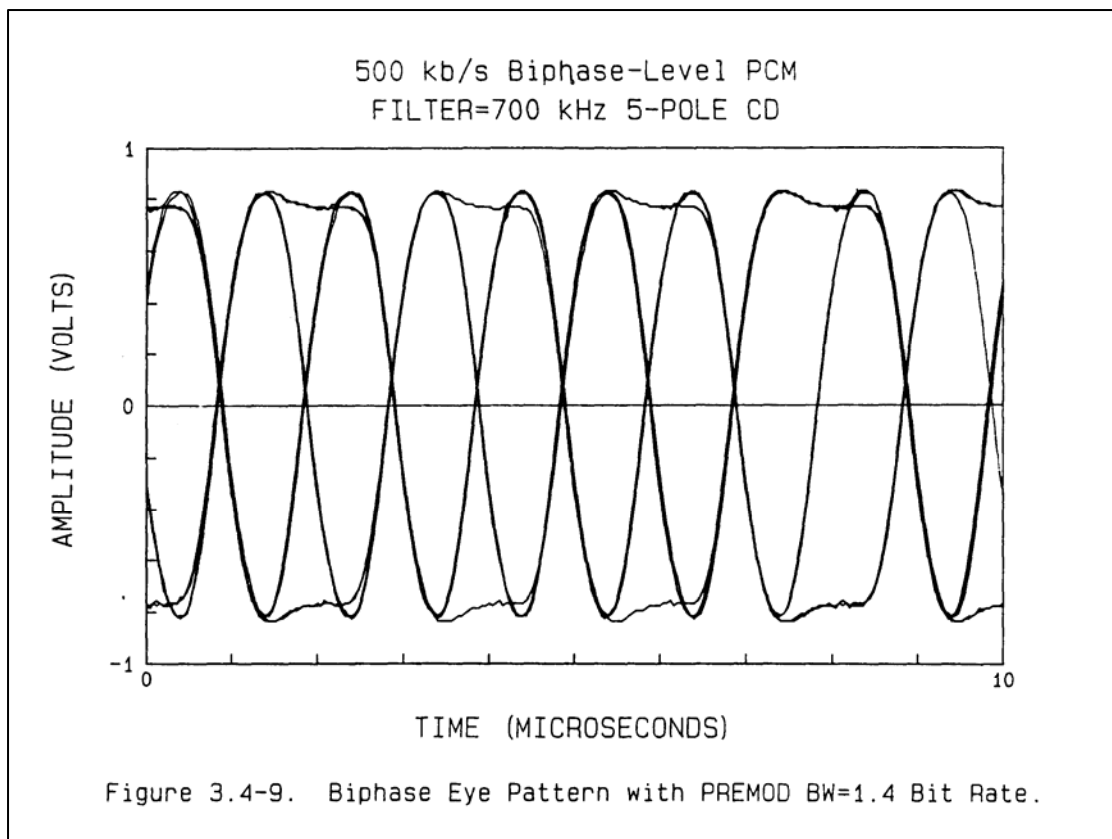

Figure 2-77. Biphase eye pattern with PREMOD BW = 1.4 bit rate.

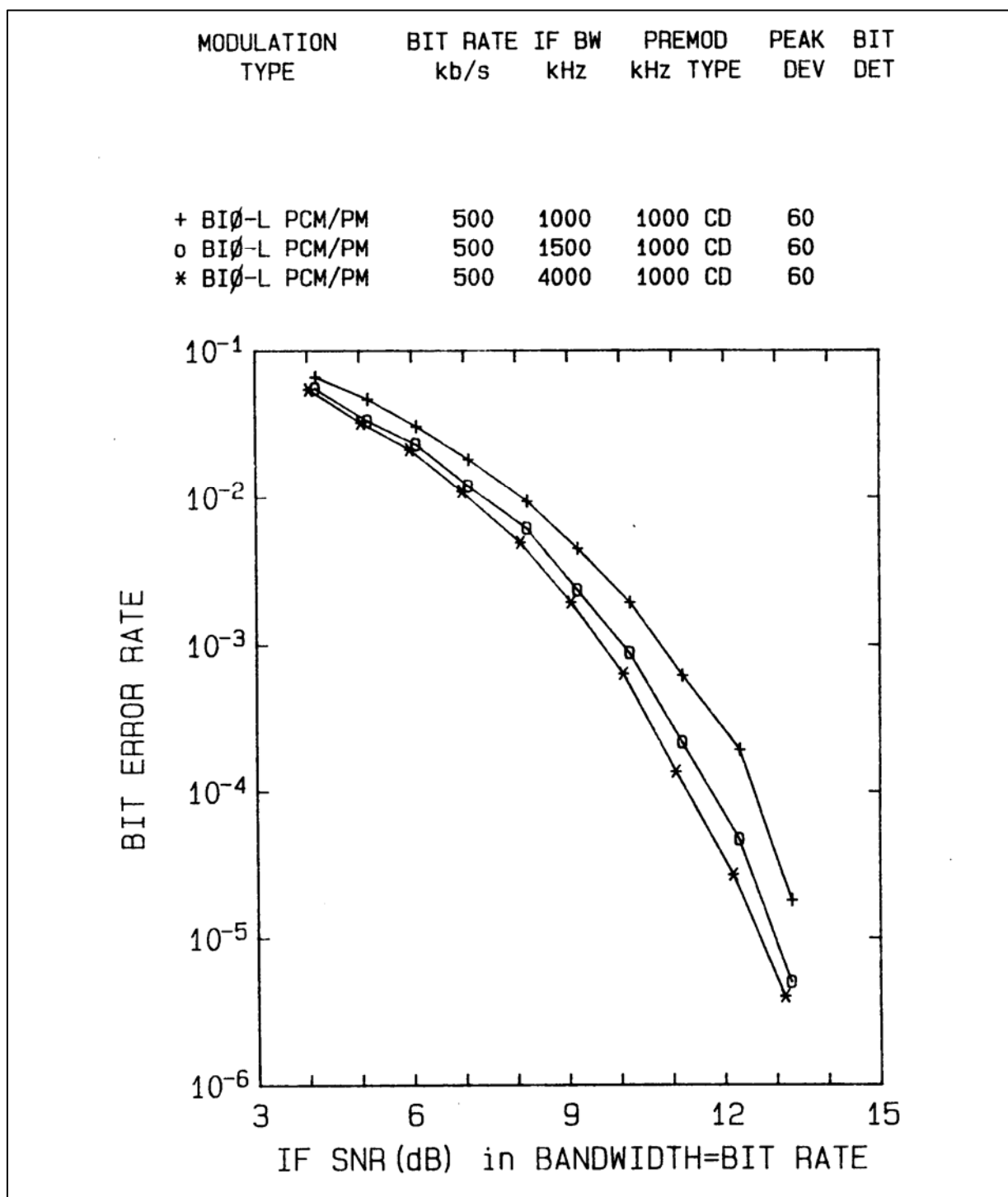

Figure 2-78. BER for peak DEV = 60 DEG. IF BW/bit rate = 2, 3, and 8.

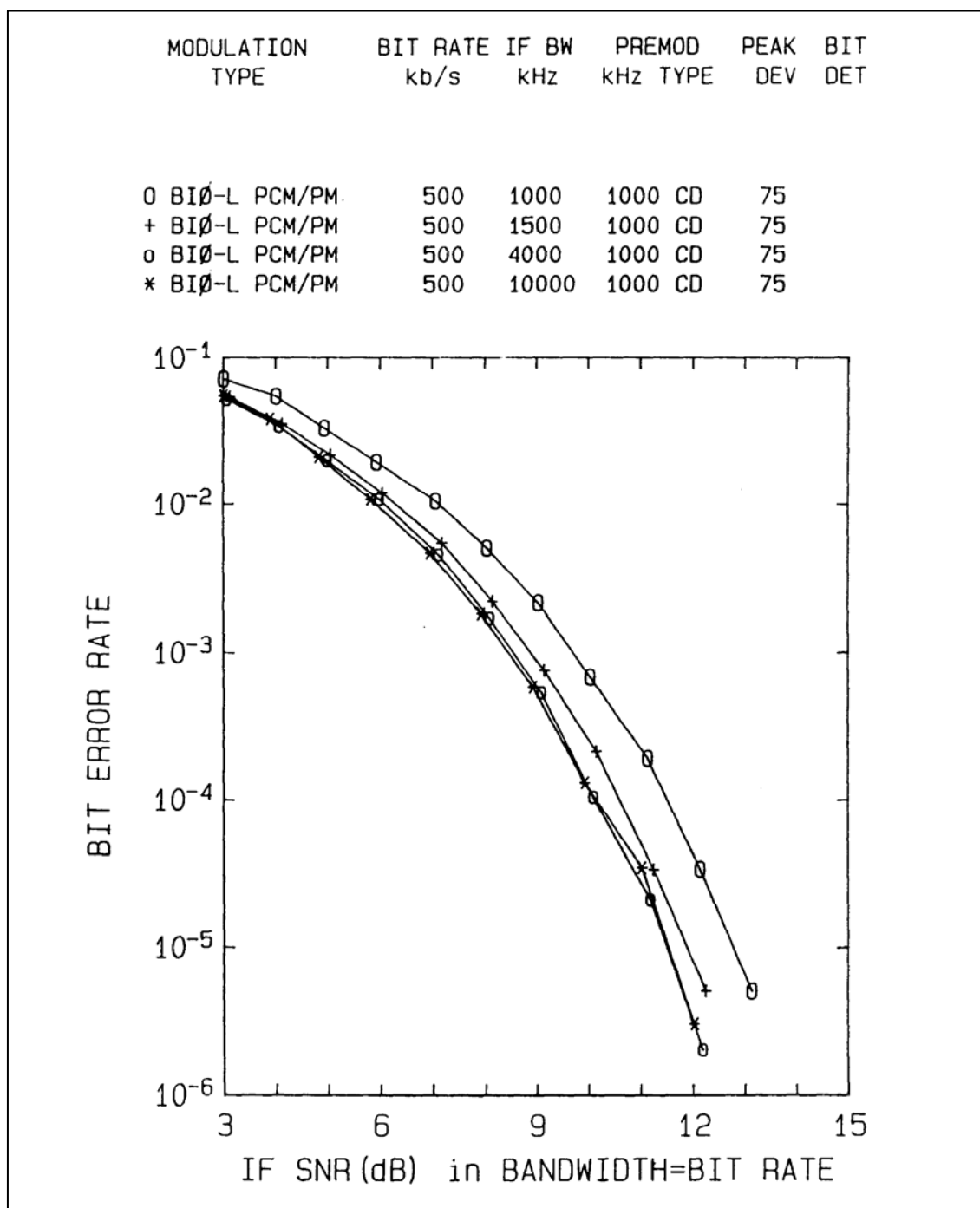

Figure 2-79. BER for peak DEV = 75 DEG, IF BW/bit rate = 2, 3, 8, and 20.

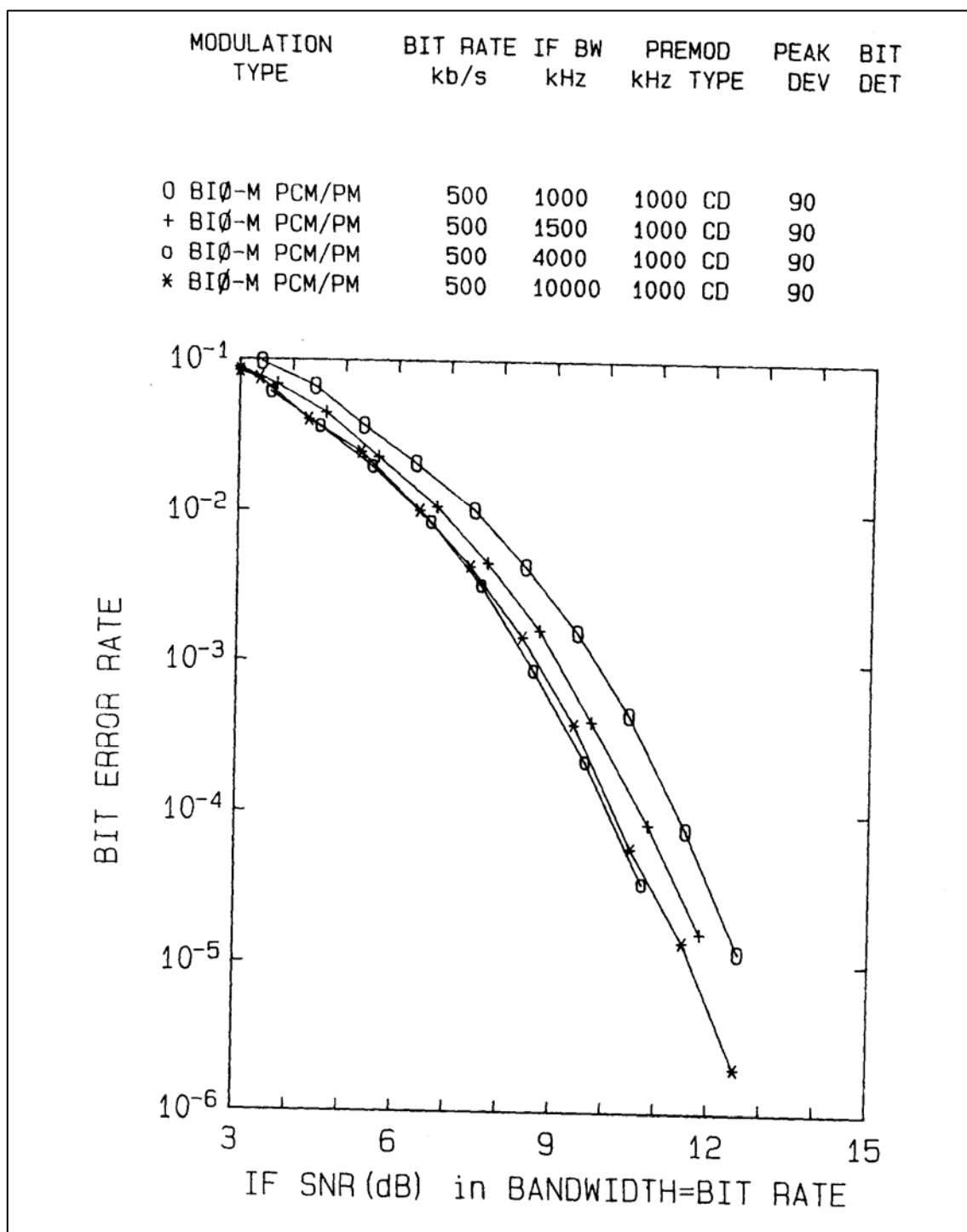

Figure 2-80. BER for peak DEV = 90 DEG, IF BW/BIT Rate = 2, 3, and 20.

2.5.6 **RF Spectra.** Radio frequency spectra are presented in Figure 2-81 through Figure 2-94 for 400 kb/s pseudo-random biphase PCM/PM with various premodulation filters and peak deviations of 60, 75, and 90°. Figure 2-81 and Figure 2-82 show the spectra that result with no premodulation filter. The IRIG criteria of 60 dB below the unmodulated carrier is not met in a 20-MHz bandwidth under these conditions. The occupied bandwidth is approximately eight times the bit rate for premodulation filters whose bandwidth is equal to the bit rate and twelve to sixteen times the bit rate for premodulation filters whose bandwidth is equal to twice the bit rate. The sideband levels are higher for larger peak deviations and generally higher with constant delay (CD) premodulation filters than with constant amplitude (CA) premodulation filters.

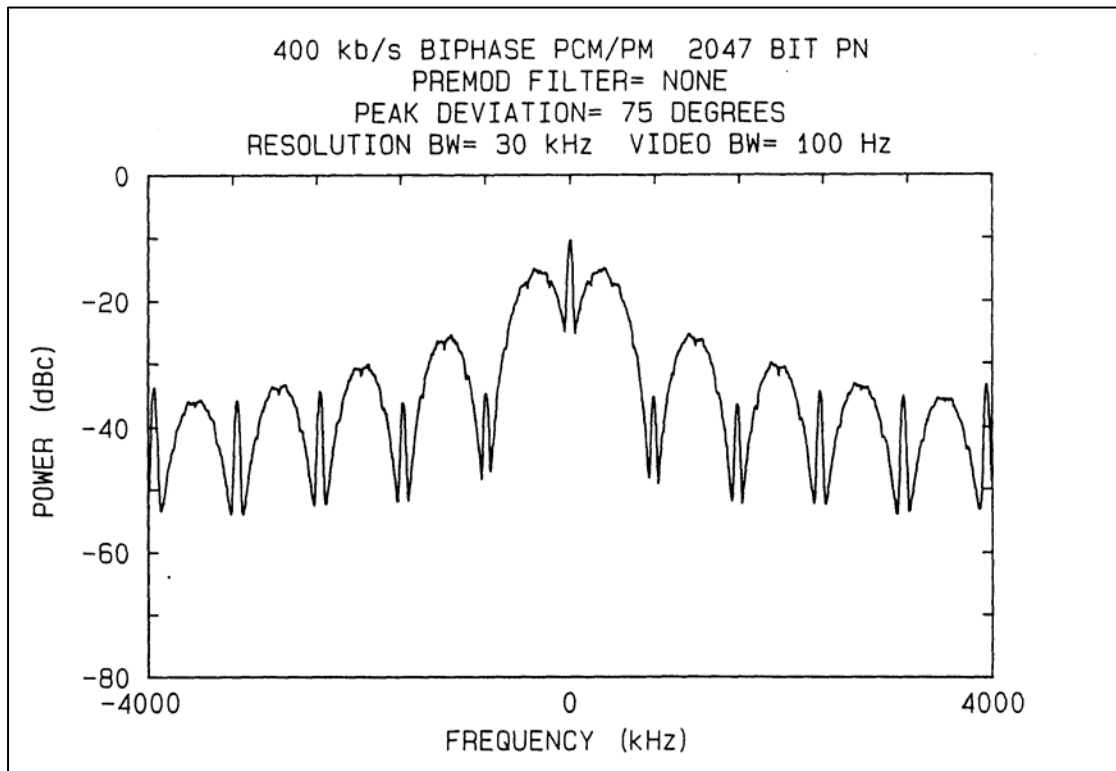

Figure 2-81. 400 kb/s biphase PCM/PM RF spectrum (PREMOD = none, DEV = 75 degrees).

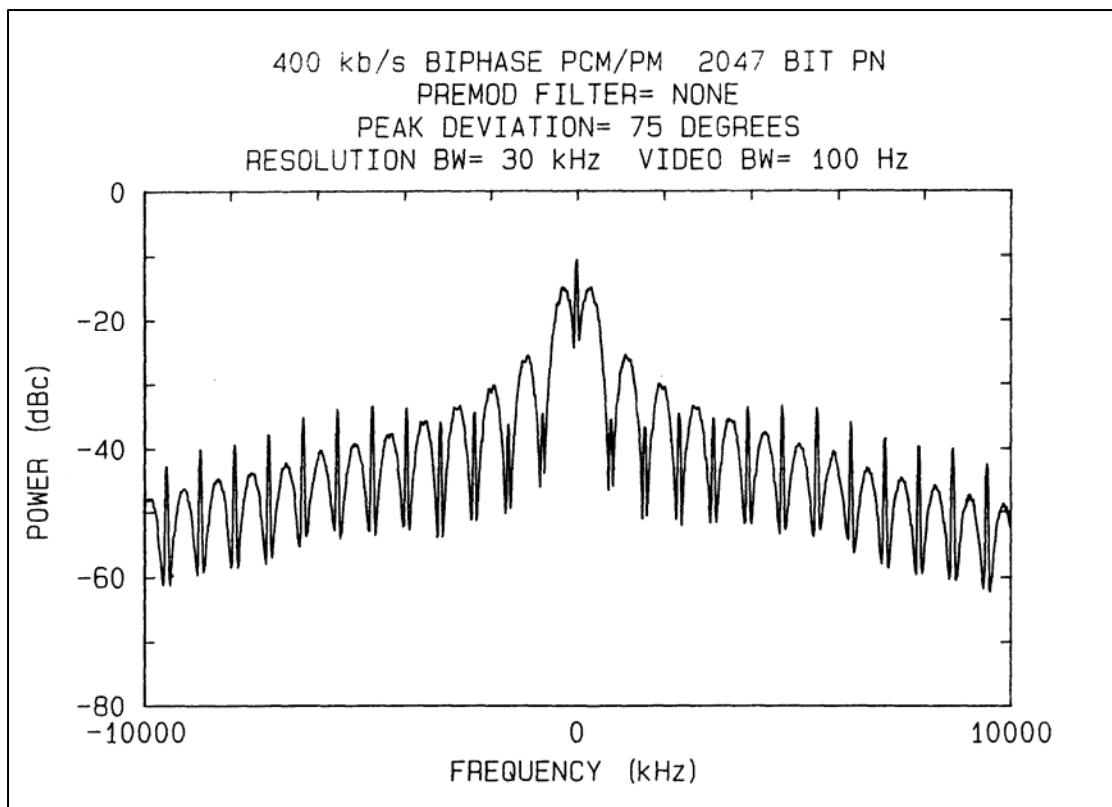

Figure 2-82. 400 kb/s biphase PCM/PM RF spectrum (20 MHz bandwidth).

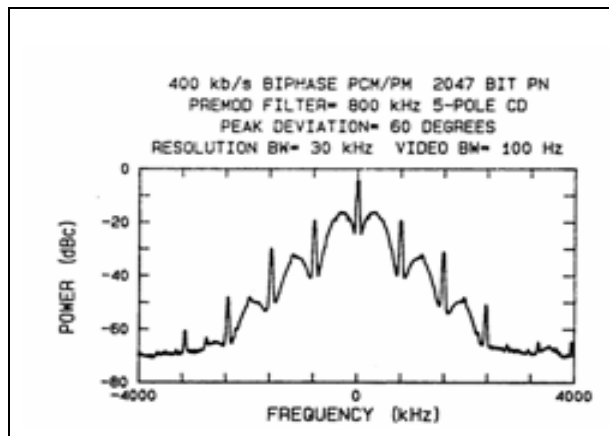

Figure 2-83. RF spectrum PREMOD = 800 kHz CD peak DEV = 60 degrees.

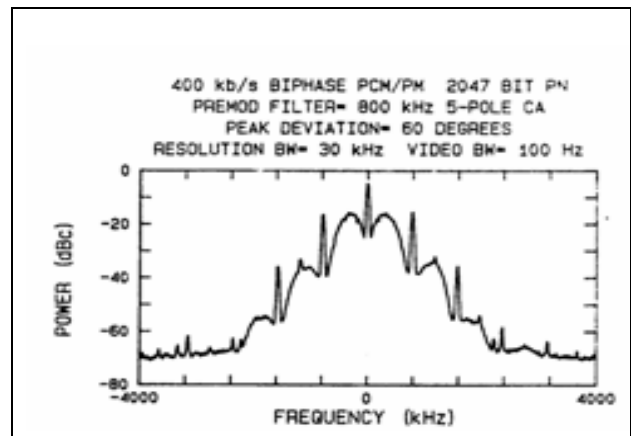

Figure 2-84. RF spectrum PREMOD = 800 kHz CA peak DEV = 60 degrees.

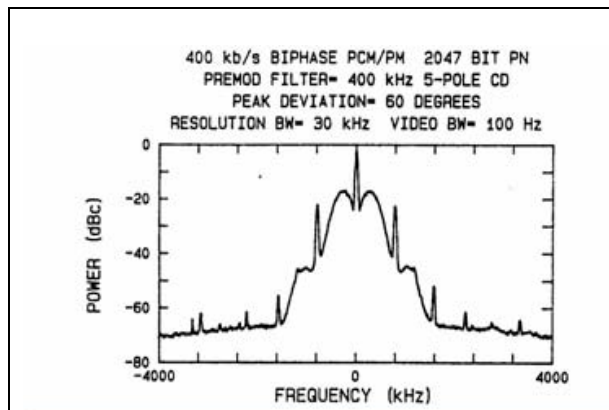

Figure 2-85. RF spectrum PREMOD = 400 kHz CD peak DEV = 60 degrees.

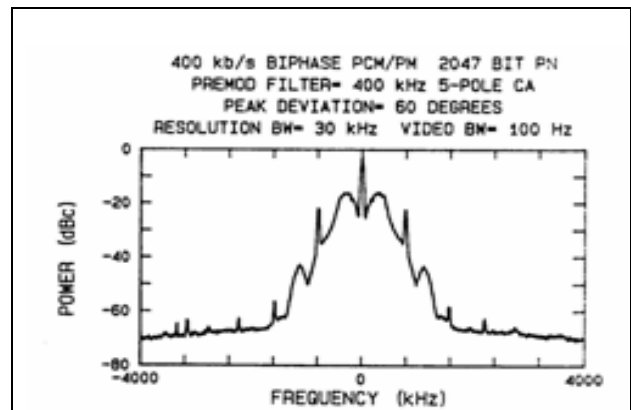

Figure 2-86. RF spectrum PREMOD = 400 kHz CA peak DEV = 60 degrees.

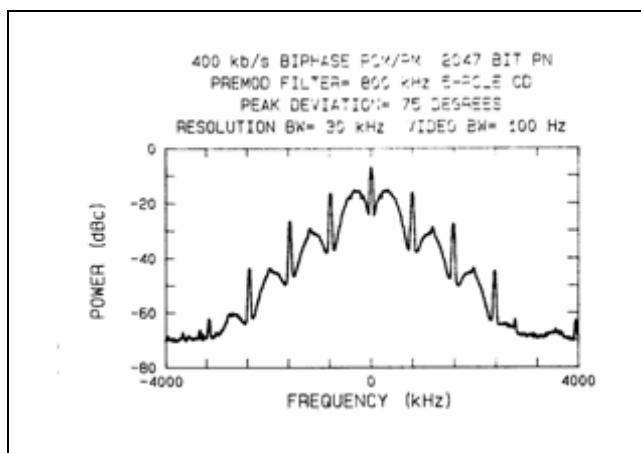

Figure 2-87. RF spectrum PREMOD = 800 kHz CD peak DEV = 75 degrees.

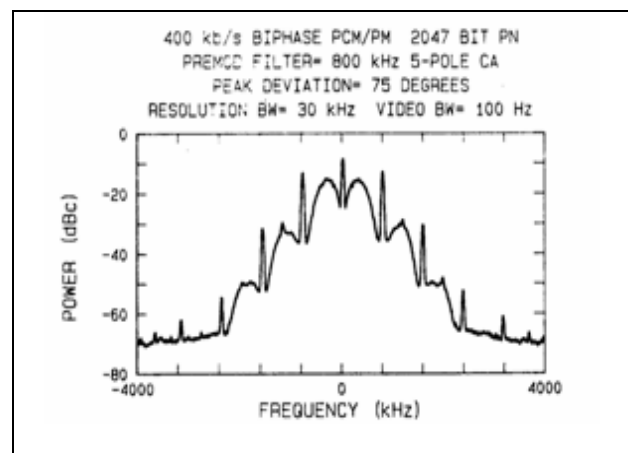

Figure 2-88. RF spectrum PREMOD = 800 kHz CA peak DEV = 75 degrees.

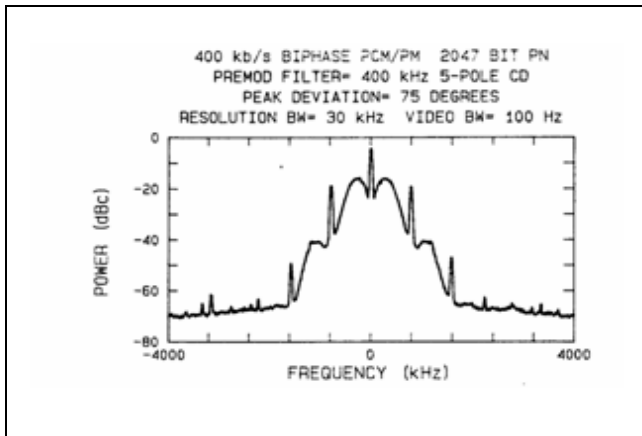

Figure 2-89. RF spectrum PREMOD = 400 kHz CD peak DEV = 75 degrees.

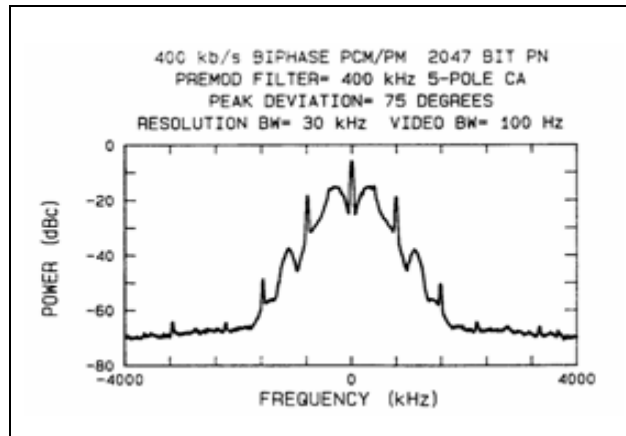

Figure 2-90. RF spectrum PREMOD = 400 kHz CA peak DEV = 75 degrees.

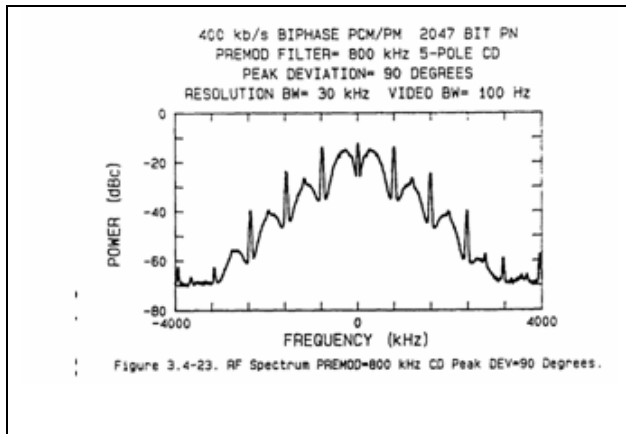

Figure 2-91. RF spectrum PREMOD = 800 kHz CD peak DEV = 90 degrees.

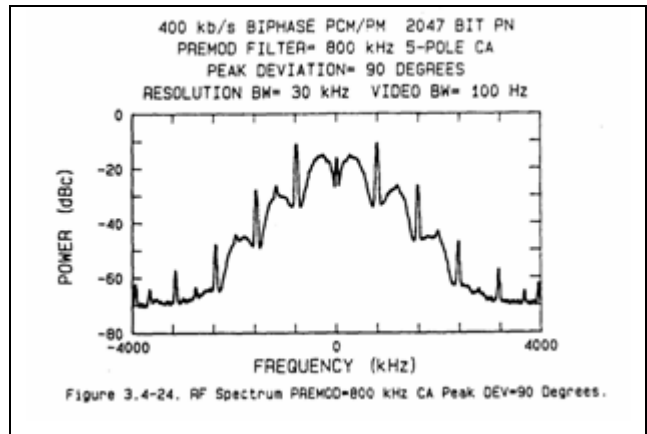

Figure 2-92. RF spectrum PREMOD = 800 kHz CA peak DEV = 90 degrees.

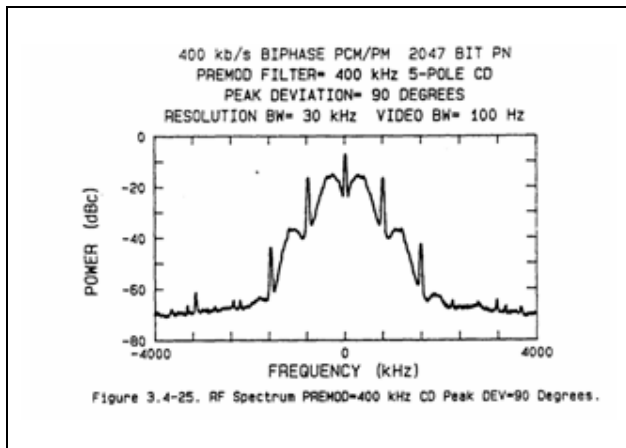

Figure 2-93. RF spectrum PREMOD = 400 kHz CD peak DEV = 90 degrees.

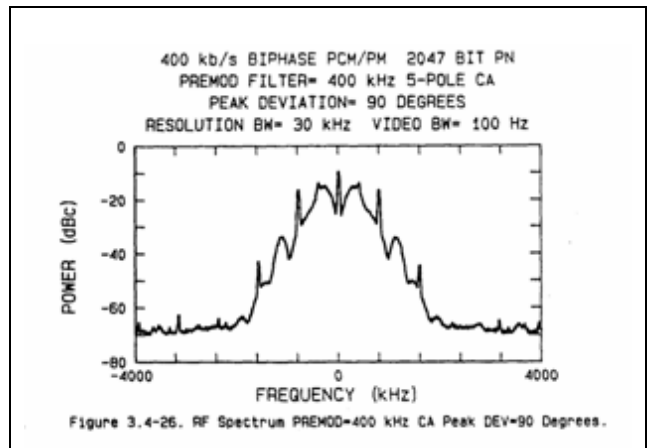
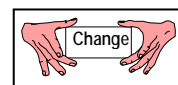

Figure 2-94. RF spectrum PREMOD = 400 kHz CA peak DEV = 90 Degrees.



2.6 FQPSK, SOQPSK, and ARTM CPM

2.6.1 Introduction. The latest version of the telemetry standards document, IRIG Standard 106, includes advanced range telemetry (ARTM) continuous phase modulation (CPM) and three interoperable variations of offset quadrature phase shift keying (OQPSK). These OQPSK variations are the Feher's-patented quadrature phase shift keying (FQPSK-B and FQPSK-JR) and the shaped OQPSK (SOQPSK-TG). These modulation methods were designed to have essentially constant envelopes and therefore minimal or no spectral spreading when amplified by a non-linear amplifier. The FQPSK signals are typically generated using quadrature (IQ) modulators while the SOQPSK-TG and ARTM CPM signals are generated using a phase or frequency modulator. The main advantage of these signals compared to PCM/FM is better spectral efficiency. The disadvantages include longer synchronization time, poorer detection efficiency, increased sensitivity to phase noise, and (often more) "spurious" signals in the transmitted output. The FQPSK-B, FQPSK-JR, and SOQPSK-TG signals are referred to as ARTM Tier 1 signals while ARTM CPM is referred to as ARTM Tier 2.

2.6.2 FQPSK-B and FQPSK-JR. FQPSK-B (see References [2o](#), [2p](#), and [2q](#)) is described in the Digcom Inc. publication, "FQPSK-B, Revision A1, Digcom-Feher Patented Technology Transfer Document, January 15, 1999." This document can be obtained under a license from:

Digcom Inc.
44685 Country Club Drive
El Macero, CA 95618
Telephone: 530-753-0738
FAX: 530-753-1788.

FQPSK-B was the original bandwidth efficient modulation technique studied under the ARTM program.

FQPSK-JR is a cross-correlated, constant envelope, spectrum shaped variant of FQPSK. It assumes a quadrature modulator architecture and synchronous digital synthesis of the I and Q channel modulating signals as outlined in Figure [2-95](#).

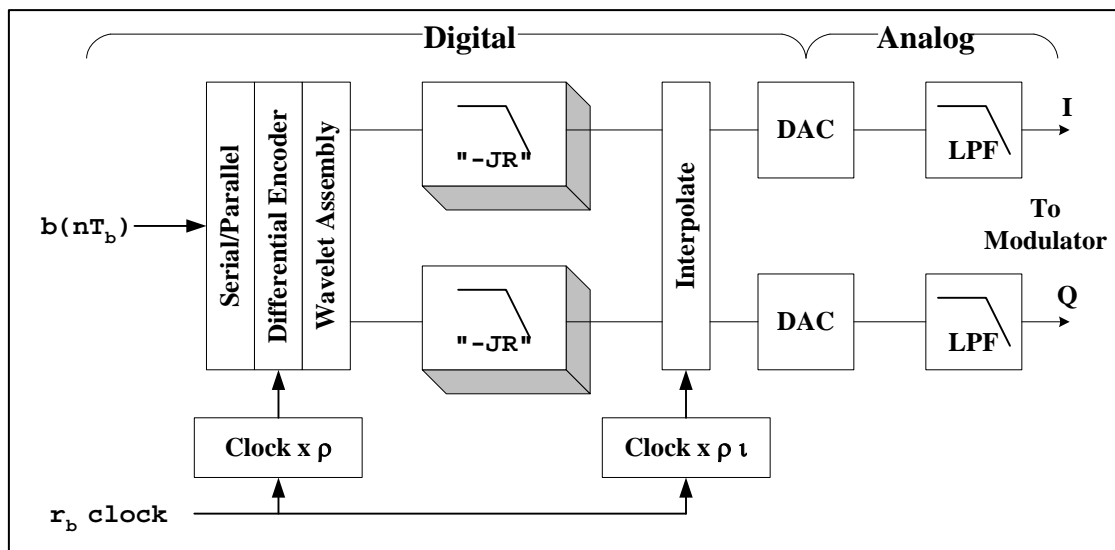

Figure 2-95. FQPSK-JR baseband signal generator.

FQPSK-JR utilizes the time domain wavelet functions defined in United States patent 4,567,602, with two exceptions. The transition functions (used in the cited patent),

$$G(t) = \begin{cases} \pm \left[1 - K \cos^2 \left(\frac{\pi t}{T_s} \right) \right] \\ \pm \left[1 - K \sin^2 \left(\frac{\pi t}{T_s} \right) \right] \end{cases} \quad (2-5)$$

$$K = 1 - A = 1 - \frac{\sqrt{2}}{2}$$

are replaced with the following transition functions:

$$G(t) = \begin{cases} \pm \sqrt{1 - A^2 \cos^2 \left(\frac{\pi t}{T_s} \right)} \\ \pm \sqrt{1 - A^2 \sin^2 \left(\frac{\pi t}{T_s} \right)} \end{cases} \quad (2-6)$$

$$A = \frac{\sqrt{2}}{2}$$

where $T_s = 2/r_b$ is the symbol period. The digital "JR" spectrum-shaping filter used for each channel is a linear phase, finite impulse response (FIR) filter. The filter is defined in terms

of its impulse response sequence $h(n)$ in Table 2-4 and assumes a fixed wavelet sample rate of $\rho = 6$ samples per symbol. The JR_{equiv} column is the aggregate response of the cascaded JR_a and JR_b filters actually used.

| TABLE 2-4. FQPSK-JR SHAPING FILTER DEFINITION | | | |
|--|---------------------|----------|----------------------|
| FILTER WEIGHT | JR_{equiv} | JR_a | JR_b |
| $h(0)$ | -0.046875 | 2^{-2} | $-(2^{-3} + 2^{-4})$ |
| $h(1)$ | 0.109375 | 2^{-2} | $(2^{-1} + 2^{-3})$ |
| $h(2)$ | 0.265625 | 2^{-2} | $(2^{-1} + 2^{-3})$ |
| $h(3)$ | 0.265625 | - | $-(2^{-3} + 2^{-4})$ |
| $h(4)$ | 0.109375 | - | - |
| $h(5)$ | -0.046875 | - | - |

Digital interpolation is used to increase sample rate, moving all alias images created by digital to analog conversion sufficiently far away from the fundamental signal frequency range that out-of-channel noise floors can be well controlled. The FQPSK-JR reference implementations currently utilize 4-stage Cascade-Integrator-Comb (CIC) interpolators with unity memory lag factor (Reference 2r). Interpolation ratio “ ι ” is adjusted as a function of bit rate such that fixed cutoff frequency post-D/A anti-alias filters can be used to cover the entire range of required data rates. The FQPSK-JR definition does not include a specific interpolation method and a post-D/A filter design. However, it is known that benchmark performance will be difficult to achieve if the combined effects of interpolation and anti-alias filter produce more than 0.4 dB excess attenuation at 0.0833 times the input sample rate and more than 1.6 dB of additional attenuation at 0.166 times the sample rate where the input sample rate is referred to the input of the interpolator assuming 6 samples per symbol.

Table 2-5 lists the mapping from the input to the modulator (after differential encoding and FQPSK-B or FQPSK-JR wavelet assembly) to the carrier phase of the modulator output. The amplitudes in Table 2-5 are $\pm a$, where “ a ” is a normalized amplitude.

| TABLE 2-5. FQPSK-B AND FQPSK-JR PHASE MAP | | |
|--|------------------|--------------------------------|
| I Channel | Q Channel | Resultant Carrier Phase |
| a | a | 45 degrees |
| $-a$ | a | 135 degrees |
| $-a$ | $-a$ | 225 degrees |
| a | $-a$ | 315 degrees |

The typical implementation of FQPSK-B or FQPSK-JR involves the application of data and a bit rate clock to the FQPSK transmitter. The data are differentially encoded and converted to I and Q signals. The I and Q channels are then cross-correlated, and specialized wavelets are assembled that minimize the instantaneous variation of $(I^2(t) + Q^2(t))$.

The FQPSK-B baseband wavelets are illustrated in Figure 2-96. The appropriate wavelet is assembled based on the current and immediate past states of I and Q. Q is delayed by one-half symbol (one bit) with respect to I as shown in Figure 2-97.

A common method of looking at I-Q modulation signals is called a vector diagram. One method of generating a vector diagram is to use an oscilloscope that has an XY mode. The vector diagram is generated by applying the I signal to the X input and the Q signal to the Y input. A sample vector diagram of FQPSK-B at the input terminals of an I-Q modulator is illustrated in Figure 2-98. Note that the vector diagram values are always within a few percent of being on a circle. Any amplitude variations may cause spectral spreading at the output of a non-linear amplifier.

Figure 2-99 illustrates a nearly ideal FQPSK-JR spectrum (blue trace) and an FQPSK-JR spectrum with moderately large modulator errors (red trace). These spectra were measured at the output of a fully saturated non-linear RF amplifier with a random pattern of “1's” and “0's” applied to the input. The bit rate for Figure 2-99 was 5 Mb/s. The peak of the spectrum was approximately -19 dBc. The 99-percent bandwidth of a nearly ideal FQPSK-B or FQPSK-JR signal is typically about 0.78 times the bit rate. Note that with a properly randomized data sequence and minimal modulator errors, FQPSK-B and FQPSK-JR do not have significant sidebands (blue trace). If large modulator errors are present, the spectral sidebands will become larger if a non-linear amplifier is used and therefore the signal will be less spectrally efficient.

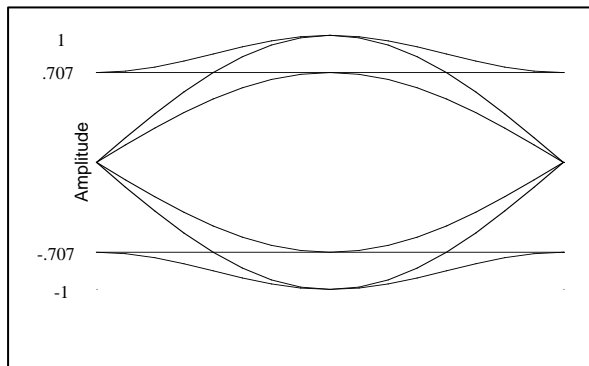

Figure 2-96. FQPSK wavelet eye diagram.

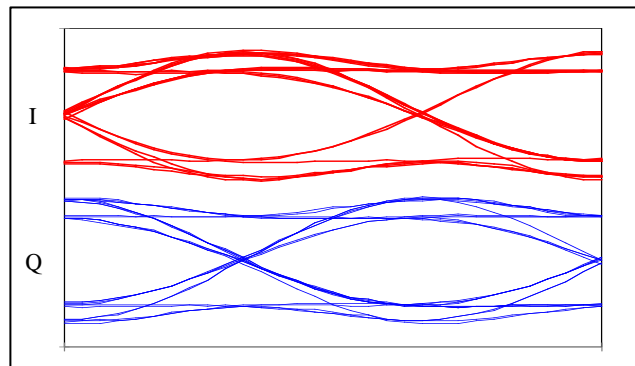

Figure 2-97. FQPSK-B I & Q eye diagrams (at input to IQ modulator).

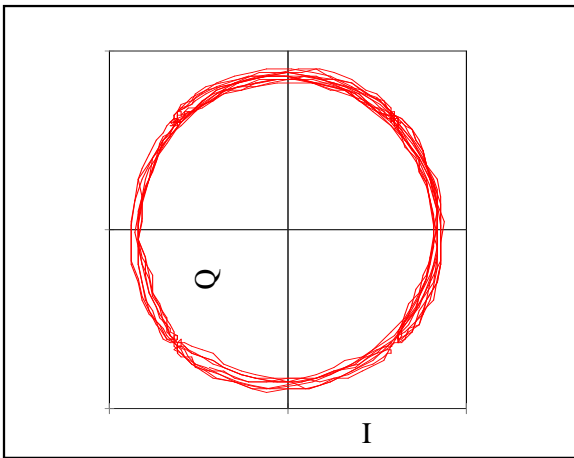

Figure 2-98. FQPSK-B vector diagram.

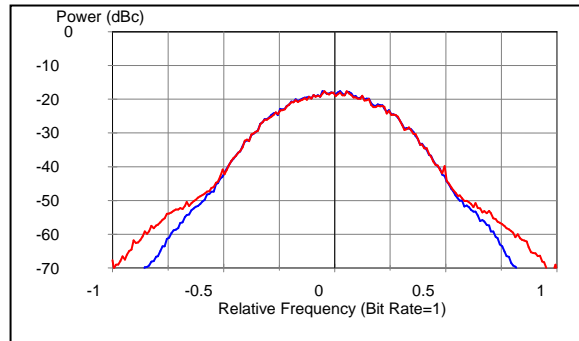

Figure 2-99. 5 Mb/s FQPSK-JR spectrum with random input data and small (blue) and large (red) modulator errors.

Figure 2-100 illustrates an FQPSK-B transmitter output with all “0’s” as the input signal. With an all “0’s” input, the differential encoder, cross-correlator, and wavelet selector provide unity amplitude sine and cosine waves with a frequency equal to 0.25 times the bit rate to the I and Q modulator inputs. The resulting signal (from an ideal modulator) would be a single frequency component offset from the carrier frequency by exactly +0.25 times the bit rate. The amplitude of this component would be equal to 0 dBc. If modulator errors exist (they typically will exist), additional frequencies will appear in the spectrum as shown in Figure 2-100. The spectral line at a normalized frequency of 0 (carrier frequency) is referred to as the remnant carrier. This component is largely caused by dc imbalances in the I and Q signals. The remnant carrier power in Figure 2-100 is approximately -31 dBc. Well designed FQPSK-B transmitters will have a remnant carrier level less than -30 dBc. The spectral component offset 0.25 times the bit rate below the carrier frequency is the other sideband. This component is largely caused by unequal amplitudes in I and Q and by a lack of quadrature between I and Q. The power in this component should be limited to -30 dBc or less for good system performance.

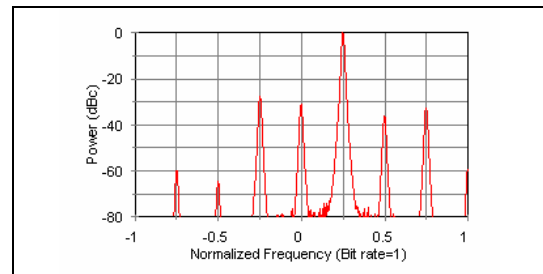

Figure 2-100. FQPSK-B spectrum with all “0’s” as the input signal.

Figure 2-101 shows the measured bit error probability (BEP) versus signal energy per bit/noise power per Hz (E_b/N_0) of two FQPSK-JR modulator/demodulator combinations including non-linear amplification and differential encoding/decoding in an additive white Gaussian noise environment (AWGN) with no fading and minimal phase noise. Other combinations of equipment may have different performance. Phase noise levels higher than those recommended in Chapter 2 of the Telemetry Standards (IRIG 106) can significantly degrade the BEP performance. Computer simulations have shown that a BEP of 10^{-5} may be achievable with an E_b/N_0 of slightly greater than 11 dB (with differential encoding/decoding). The purpose of the differential encoder/decoder is to resolve the phase detection ambiguities that are inherent in QPSK, OQPSK, and FQPSK modulation methods. The differential encoder/decoder used in this standard will cause one isolated symbol error to appear as two bits in error at the demodulator output. However, many aeronautical telemetry channels are dominated by fairly long burst error events, and the effect of the differential encoder/decoder will often be masked by the error events.

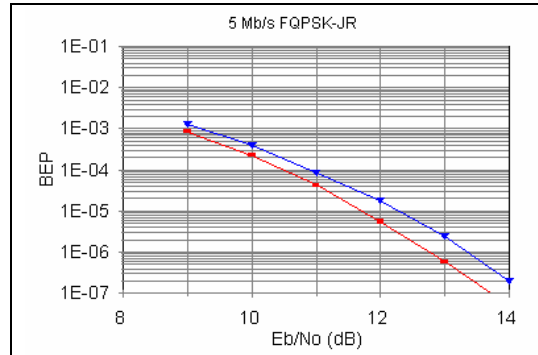

Figure 2-101. BEP versus E_b/N_0 for FQPSK-JR.

The synchronization speed for FQPSK and SOQPSK is a function of the demodulator used, the demodulator acquisition range, and the signal-to-noise ratio. The measured synchronization time varied from about 3,000 bits to 400,000 bits (Reference [2s](#)).

2.6.3 SOQPSK-TG. SOQPSK is a family of constant envelope CPM waveforms defined by Mr. T. Hill (References [2t](#), [2u](#), and [2v](#)). It is most simply described as a non-linear frequency modulation modeled as shown in Figure 2-102.

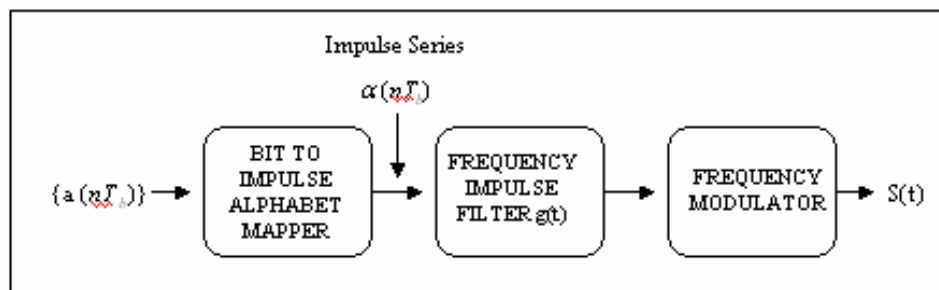

Figure 2-102. Basic SOQPSK block diagram.

The SOQPSK waveform family is uniquely defined in terms of impulse excitation of a *frequency impulse shaping filter function* $g(t)$

$$g(t) = n(t)w(t) \quad (2-7)$$

where

$$n(t) \equiv \left[\frac{A \cos \pi \theta_1(t)}{1 - 4\theta_1^2(t)} \right] \left[\frac{\sin \theta_2(t)}{\theta_2(t)} \right] \quad (2-8)$$

$$\theta_1(t) = \frac{\rho B t}{T_s}$$

$$\theta_2(t) = \frac{\pi B t}{T_s}$$

$$w(t) \equiv \begin{cases} 1, & \left| \frac{t}{T_s} \right| \leq T_1 \\ \frac{1}{2} \left[1 + \cos \left(\frac{\pi \left(\left| \frac{t}{T_s} \right| - T_1 \right)}{T_2} \right) \right] & , T_1 < \left| \frac{t}{T_s} \right| \leq T_1 + T_2 \\ 0, & \left| \frac{t}{T_s} \right| > T_1 + T_2 \end{cases} \quad (2-9)$$

$n(t)$ is a modified spectral raised cosine filter of amplitude A , roll-off factor ρ , and having an additional time scaling factor B . The function $w(t)$ is a time domain windowing function that limits the duration of $g(t)$. The amplitude scale factor A is chosen such that

$$\int_{-(T_1+T_2)T_s}^{(T_1+T_2)T_s} g(t) dt = \frac{\pi}{2} \quad (2-10)$$

Given a time series binary data sequence

$$\vec{a} = (\dots, a_{-2}, a_{-1}, a_0, a_1, a_2, \dots) \quad (2-11)$$

wherein the bits are represented by normalized antipodal amplitudes $\{+1, -1\}$, the ternary impulse series is formed with the following mapping rule.

$$\alpha = (-1)^{i+1} \frac{a_{i-1}(a_i - a_{i-2})}{2} \quad (2-12)$$

This mapping rule forms a data sequence alphabet of three values $\{+1, 0, -1\}$. It is important to note that this modulation definition does not establish an absolute relationship between the digital in-band inter-switch trunk signaling (dibits) of the binary data alphabet and

transmitted phase as with conventional quadriphase OQPSK implementations. In order to achieve interoperability with coherent FQPSK-B demodulators, some form of precoding must be applied to the data stream prior to, or in conjunction with, conversion to the ternary excitation alphabet. However, to guarantee full interoperability with the other waveform options, the polarity relationship between frequency impulses and resulting frequency or phase change must be controlled. Thus, SOQPSK modulators proposed for this application shall guarantee that an impulse of value of (+1) will result in an advancement of the transmitted phase relative to that of the nominal carrier frequency (i.e., the instantaneous frequency is above the nominal carrier).

For purposes of the IRIG 106 Standard, only one specific variant of SOQPSK (called SOQPSK-TG) is acceptable. SOQPSK-TG is defined by the parameter values given in Table 2-6.

| TABLE 2-6. SOQPSK-TG PARAMETERS | | | | |
|---------------------------------|--------|------|-------|-------|
| SOQPSK TYPE | ρ | B | T_1 | T_2 |
| SOQPSK-TG | 0.70 | 1.25 | 1.5 | 0.50 |

As discussed above, interoperability with FQPSK-B equipment requires a particular precoding protocol or a functional equivalent thereof. A representative model is shown in Figure 2-103.

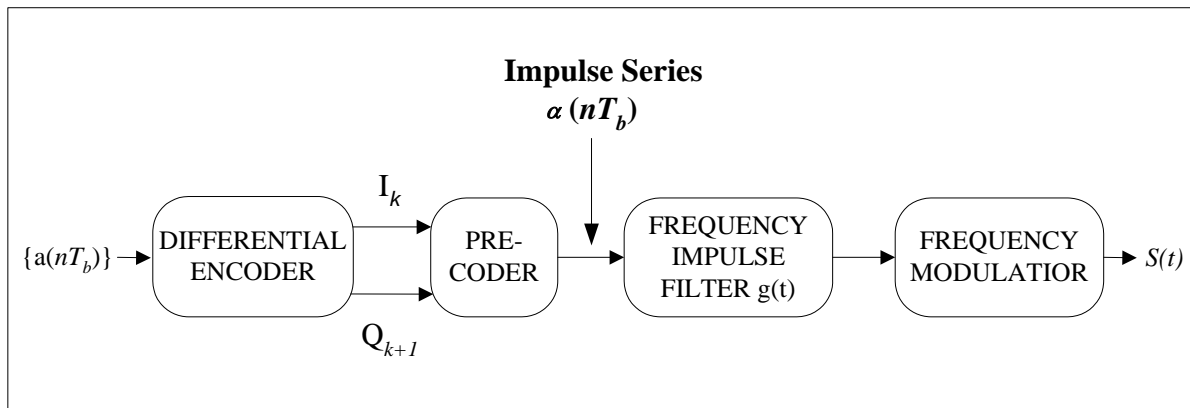

Figure 2-103. SOQPSK transmitter.

The differential encoder block will be implemented in accordance with the definition of in paragraph 2.6.4. Given the symbol sequences I_k and Q_k , and the proviso that a normalized impulse sign of +1 will increase frequency, the pre-coder will provide interoperability with the FQPSK signals defined herein if code symbols are mapped to frequency impulses in accordance with Table 2-7 where $\Delta\Phi$ is the phase change.

| TABLE 2-7. SOQPSK PRE-CODING TABLE FOR IRIG-106 COMPATIBILITY | | | | | | | | | |
|---|-----------|-----------|--------------|------------|-----------------------------------|-------|-----------|--------------|----------------|
| MAP α_K FROM I_K | | | | | MAP α_{K+1} FROM Q_{K+1} | | | | |
| I_k | Q_{k-1} | I_{k-2} | $\Delta\Phi$ | α_k | Q_{k+1} | I_k | Q_{k-1} | $\Delta\Phi$ | α_{k+1} |
| -1 | X* | -1 | 0 | 0 | -1 | X* | -1 | 0 | 0 |
| +1 | X* | +1 | 0 | 0 | +1 | X* | +1 | 0 | 0 |
| -1 | -1 | +1 | $-\pi/2$ | -1 | -1 | -1 | +1 | $+\pi/2$ | +1 |
| -1 | +1 | +1 | $+\pi/2$ | +1 | -1 | +1 | +1 | $-\pi/2$ | -1 |
| +1 | -1 | -1 | $+\pi/2$ | +1 | +1 | -1 | -1 | $-\pi/2$ | -1 |
| +1 | +1 | -1 | $-\pi/2$ | -1 | +1 | +1 | -1 | $+\pi/2$ | +1 |

* Note: Does not matter if “X” is a +1 or a -1

The SOQPSK-TG signal amplitude is constant and the phase trajectory is determined by the coefficients in Table 2-6. Therefore, SOQPSK-TG can be implemented using a precision phase or frequency modulator with proper control of the phase trajectory. Figure 2-104 illustrates the measured phase trajectory of an SOQPSK-TG signal. The vertical lines correspond approximately to the “bit” decision times.



Figure 2-104. Measured SOQPSK-TG phase trajectory.

The power spectrum of a random 5 Mb/s SOQPSK-TG signal is shown in Figure 2-105. This spectrum was measured using a 30 kHz resolution bandwidth. The -60 dBc bandwidth of this 5 Mb/s signal was about 7.34 MHz. Note that the maximum power level is about -19 dBc.

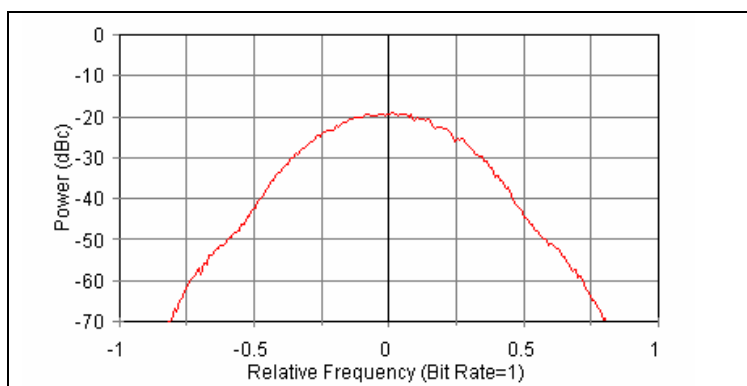

Figure 2-105. SOQPSK-TG power spectrum (5 mb/s).

Figure 2-106 shows the measured bit error probability (BEP) versus signal energy per bit/noise power per Hz (E_b/N_0) of two SOQPSK-TG modulator/demodulator combinations including non-linear amplification and differential encoding/decoding in an additive white Gaussian noise environment (AWGN) with no excess phase noise. Other combinations of equipment may have different performance. Phase noise levels higher than those recommended in Chapter 2 of IRIG 106 can significantly degrade the BEP performance.

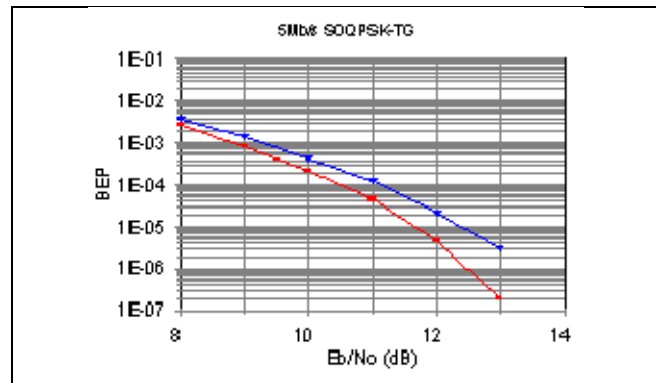

Figure 2-106. BEP versus E_b/N_0 performance of 5 Mb/s SOQPSK-TG.

Figure 2-107 shows an example of degraded BEP (blue line) caused by excessive phase noise in the telemetry receiver. The amount of degradation is a function of the excess phase noise at various frequencies.

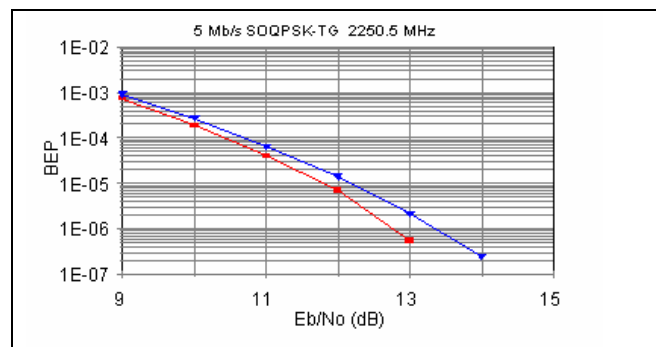

Figure 2-107. BEP versus E_b/N_0 performance of 5 Mb/s SOQPSK-TG with acceptable phase noise (red line) and excess phase noise (blue line).

Figure 2-108 shows the effect of various IF filter bandwidths on a 20 Mb/s SOQPSK-TG signal. The IF filters used for this test were SAW filters. The use of an IF filter bandwidth of one-half the bit rate caused significant degradation but filters of 0.6 times the bit rate or wider performed about the same. SOQPSK and FQPSK BEPs are essentially independent of the IF filter bandwidth as long as the IF filter bandwidth is at least 0.6 times the bit rate, the filter has good group delay characteristics, and there are no large frequency errors.

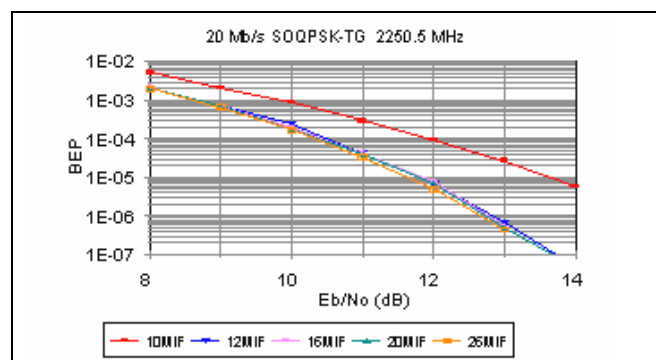

Figure 2-108. SOQPSK-TG BEP performance with various IF bandwidths.

2.6.4 Differential encoding. Differential encoding shall be provided for FQPSK-B, FQPSK-JR, and SOQPSK-TG and shall be consistent with the following definitions:

The NRZ-L data bit sequence $\{b_n\}$ is sampled periodically by the transmitter at time instants

$$t = nT_b \quad n = 0, 1, 2, \dots \quad (2-13)$$

where T_b is the NRZ-L bit period. Using the bit index values n as references to the beginning of symbol periods, the differential encoder alternately assembles I channel and Q channel symbols to form the sequences

$$I_2, I_4, I_6, \dots$$

and

$$Q_3, Q_5, Q_7, \dots$$

according to the following rules:

$$I_{2n} = b_{2n} \oplus \overline{Q}_{(2n-1)} \quad n > 0 \quad (2-14)$$

$$Q_{(2n+1)} = b_{(2n+1)} \oplus I_{2n} \quad n > 0 \quad (2-15)$$

where \oplus denotes the exclusive-or operator, and the bar above a variable indicates the 'not' or inversion operator. Q channel symbols are offset (delayed) relative to I channel symbols by one bit period.

2.6.5 ARTM CPM. ARTM CPM (Reference [2w](#)) is a quaternary signaling scheme in which the instantaneous frequency of the modulated signal is a function of the source data stream. The frequency pulses are shaped for spectral containment purposes. The modulation index alternates at the symbol rate between two values to improve the likelihood that the transmitted data is faithfully recovered. Although the following description is in terms of carrier frequency, other representations and generation methods exist that are equivalent. A block diagram of a conceptual ARTM CPM modulator is illustrated in Figure [2-109](#). Source bits are presented to the modulator and are mapped into impulses that are applied to a filter with an impulse response $g(t)$. The resulting waveform $f(t)$ is proportional to the instantaneous frequency of the desired modulator output. This signal can be used to frequency modulate a carrier to produce an RF signal representation.

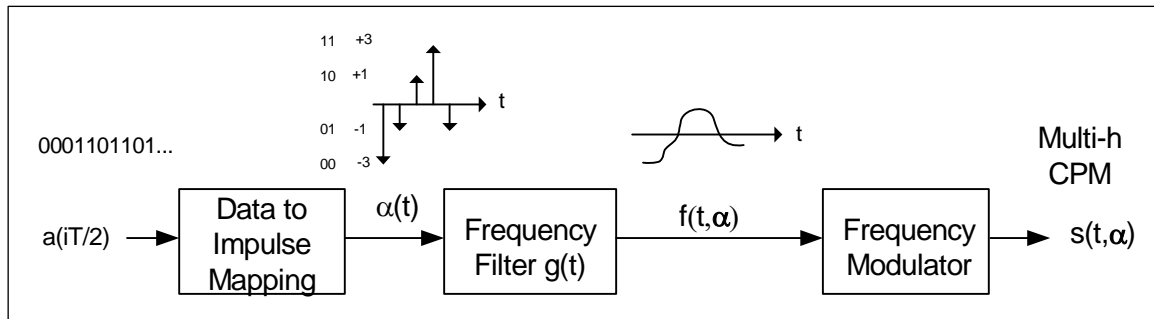

Figure 2-109. Conceptual CPM modulator.

Variables and function definitions in Figure 2-109 above are as follows:

- $a(iT/2) = i^{\text{th}}$ bit of binary source data, either a 0 or 1
- The frequency pulse shape for ARTM CPM is a three symbol long raised cosine pulse defined by for $0 \leq t \leq 3T$ (2-16)
- $T =$ Symbol period equal to $2/(\text{bit rate in bits/second})$
- $\alpha(iT) =$ i^{th} impulse with area equal to either a +3, +1, -1 or -3 determined by Table 2-8 below. Note that an impulse is generated for each dibit pair (at the symbol rate).
- $f(t, \alpha) =$ frequency filter output equal to

$$\pi h_i \sum_{i=-\infty}^{+\infty} \alpha(iT) g(t - iT) \quad (2-17)$$

- $h =$ modulation index; h alternates between h_1 and h_2 where $h_1 = 4/16$, $h_2 = 5/16$

| TABLE 2-8. DIBIT TO IMPULSE AREA MAPPING | |
|--|--------------|
| INPUT DIBIT [a(i) a(i+1)] | IMPULSE AREA |
| 11 | +3 |
| 10 | +1 |
| 01 | -1 |
| 00 | -3 |

For more information on the ARTM CPM waveform, please refer to Reference [2m](#). ARTM CPM is a quaternary signaling scheme in which the modulation index alternates at the symbol rate between $h=4/16$ and $h=5/16$. The purpose of alternating between two modulation indices is to maximize the minimum distance between data symbols, which results in minimizing the bit error probability. These particular modulation indices were selected as a good tradeoff between spectral efficiency and data-detection ability.

Figure 2-110 shows the power spectrum of a 5 Mb/s ARTM CPM signal. The maximum power level was about -17 dBc. The -60 dBc bandwidth of this 5 Mb/s signal was about 5.54 MHz.

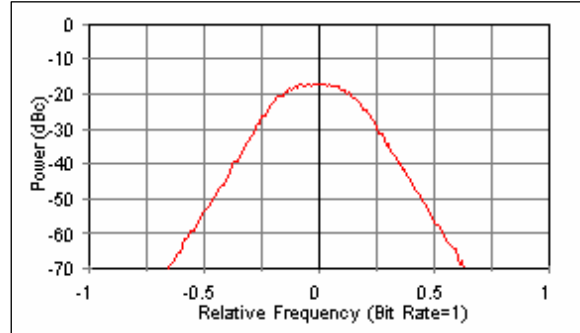

Figure 2-110. Power spectrum of 5 MB/S ARTM CPM.

Figure 2-111 shows the measured BEP versus E_b/N_o of 5 Mb/s ARTM CPM with acceptable phase noise (red curve) and excess phase noise (blue curve). Note that the power spectrum of ARTM CPM is about 25 percent narrower than that of SOQPSK-TG but the BEP performance is worse. ARTM CPM is also more susceptible to phase noise than SOQPSK-TG, which can be easily seen by comparing Figure 2-107 and Figure 2-111. The same receivers were used to collect the data in both figures and the degradation in Figure 2-111 is significantly larger than it is in Figure 2-107.

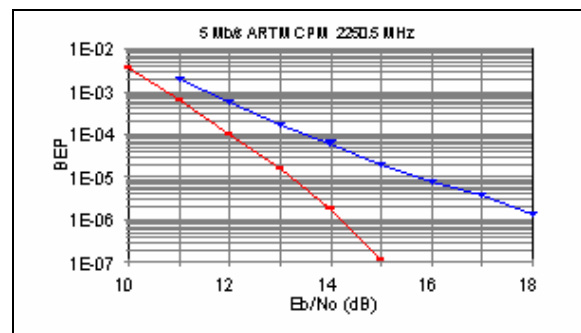

Figure 2-111. BEP versus E_b/N_o performance of 5 Mb/s ARTM CPM.

2.7 Pulse Amplitude Modulation/Frequency Modulation

2.7.1 Introduction. The terms pulse amplitude modulation (PAM) and frequency modulation (FM) indicate a modulation technique (see References [2x](#), [2y](#), [2z](#), and [2aa](#)) in which the analog information signal is periodically sampled and the samples are used to frequency modulate the carrier signal. The NRZ-PAM/FM technique is easily employed in analog systems designs since it only requires a commutator (electronic switch) to produce the amplitude levels. Pulse amplitude modulation is the simplest form of time-division multiplexing (TDM) for analog source signals because the samples of data are transmitted without conversion to another form. A very important requirement of PAM, as with any TDM system, is that the decommutator be correctly synchronized with the commutator. As a result, it is necessary to include synchronization signals in the commutated data. The IRIG Telemetry Standards specify that the synchronization pattern for NRZ-PAM shall be, in the order given: zero scale for a period T , full scale for a period $3T$, and a level not to exceed 50 percent of full scale for a period T , where $T = 1/(\text{PAM channel rate})$. The channel immediately following this pattern is defined to be channel 1. Data channels cannot be properly sorted out until the decommutator recognizes the synchronization pattern, thus identifying the time space allotted to each data channel.

There are two major sampling methods for NRZ-PAM. These methods are frequently referred to as flat-top and natural sampling (see illustrations in Figure [2-112](#) and Figure [2-113](#)). The difference between the methods is that a sample-and-hold circuit is part of the commutator circuitry with flat-top sampling. When natural sampling is used, the signal variations during the sampling time are passed on as part of the PAM signal (Figure 2-113).

2.7.2 RF Deviation. The most commonly used values for NRZ-PAM peak RF deviation are 125 kHz for PAM channel rates below 50 kCh/s and 2.5 times the PAM channel rate for rates above 50 kCh/s; for example, a 100 kCh/s PAM signal would typically use a 250 kHz peak deviation. A peak deviation of 2.5 times the channel rate *will* result in a raw decommutator output rms noise level of approximately 2 percent of full scale for a 12 dB IF SNR and a receiver IF bandwidth between 1.2 and 2 times the peak-to-peak PAM RF deviation. (Assumes that the rms value of incidental FM is less than 1 percent of the peak-to-peak deviation.) The peak-to-peak transmitter deviation should be at least 50 times the peak incidental FM expected for frequencies between 50 kHz and the PAM channel rate.

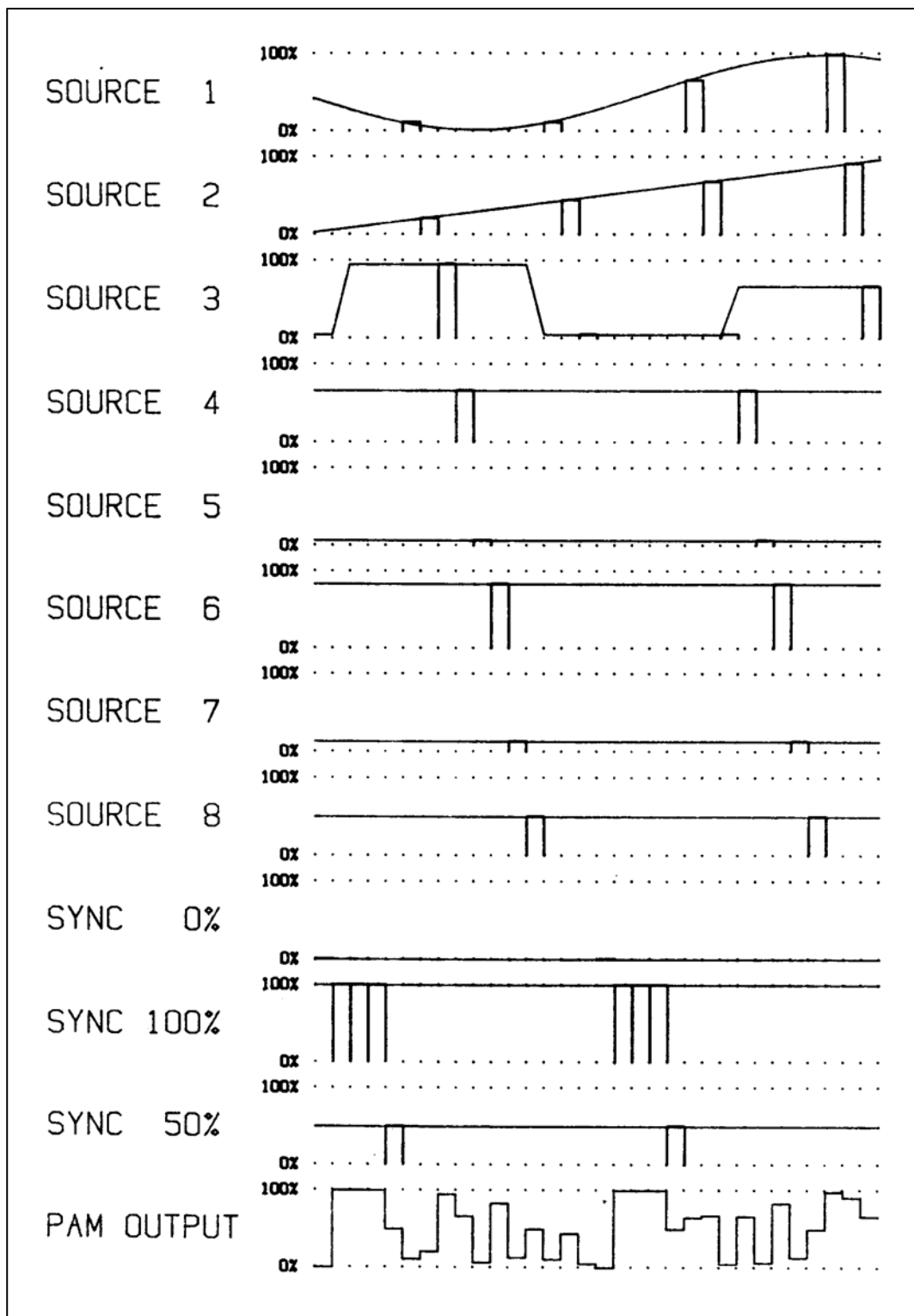

Figure 2-112. NRZ PAM signal with flat-top sampling.

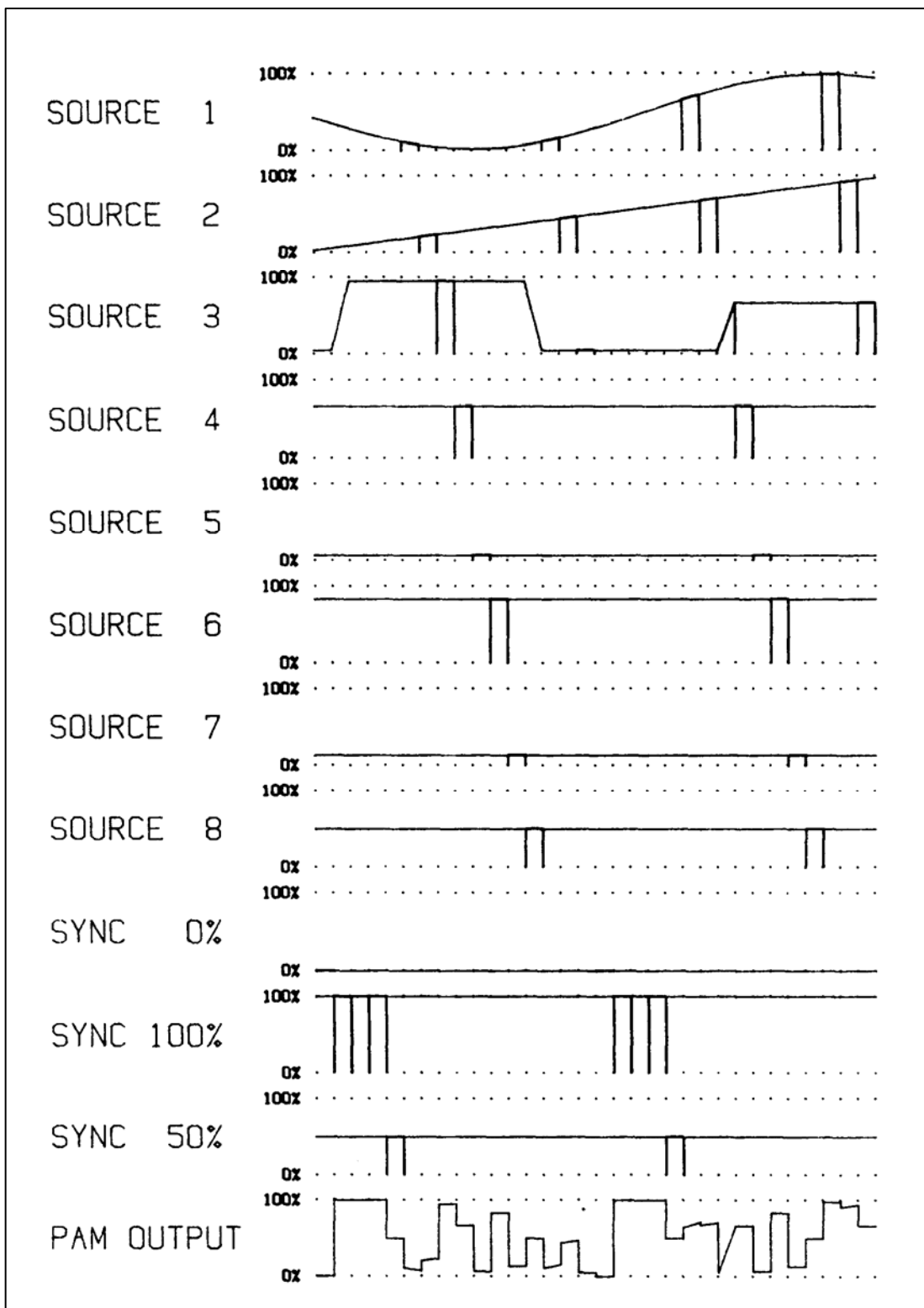

Figure 2-113. NRZ PAM Signal with Natural Sampling.

2.7.3 Premodulation Filter. The recommended premodulation filter bandwidth for NRZ PAM is twice the PAM channel rate (Reference [2bb](#)). The filter should be a 4 to 6-pole linear phase low-pass filter. A 1-pole RC filter can also be used. The primary disadvantage of a 1-pole filter is that the PAM baseband and RF spectra roll off more slowly.

2.7.4 SNR at Output of NRZ PAM Decommutator. An equation, which can be used to calculate the signal-to-noise ratio (SNR) at the output of a PAM decommutator, will be described in this section. It has been assumed that the receiver is above FM threshold and that all noise is due to wideband, white, Gaussian noise at the demodulator input. This equation will relate the rms noise to full scale signal (peak-to-peak). In other words, if the rms value of the noise is 1 percent of full scale (100 mV rms noise for 0.0 V to 10 V output), the SNR will be 40 dB ($20 \log (10/0.1)$). Other publications have used various definitions of SNR. A common one is to define the signal as the rms value of a full scale sine wave. The definition used in this section gives SNRs that are 9 dB greater than the rms sine wave definition. The full scale signal definition is used here because most error analysis is done as a percentage of full scale. This section *will* also show plots of the effects of noise on dc signals and triangle waves for various SNRs.

A typical PAM decommutator can be modeled as a linear phase low-pass filter followed by a synchronized sample and hold. The typical low-pass filter bandwidth is equal to the PAM channel rate. Therefore, the output SNR (in dB) can be calculated using the normal equation for low-pass filtered FM above FM threshold

$$(S/N)_{PAM} = SNR_{IF} + F_{CORR} + 20 \log \left\{ \frac{(12 B_{IF})^{1/2} \Delta f}{(B_{LPF})^{3/2}} \right\} \quad (2-18)$$

where

F_{CORR} is the correction factor due to non-ideal filters
 SNR_{IF} is the IF SNR
 B_{IF} is the IF equivalent noise power bandwidth
 B_{LPF} is the low-pass filter bandwidth
 Δf is the peak deviation.

Typical values for F_{CORR} are -3 to -6 dB depending on the number of poles in the filter and the accuracy of the -3 dB point.

Assume

$$\begin{aligned}
 &25 \text{ kCh/s PAM} \\
 B_{\text{IF}} &= 640 \text{ kHz equivalent noise power bandwidth} \\
 \Delta f &= 125 \text{ kHz peak deviation} \\
 \text{SNR}_{\text{IF}} &= 15 \text{ dB IF SNR} \\
 F_{\text{CORR}} &= -6 \text{ dB filter correction factor}
 \end{aligned}$$

then

$$(\text{S/N})_{\text{PAM}} = 15 - 6 + 20 \log \left\{ \frac{[12(640)]^{1/2} 125}{(25)^{3/2}} \right\} = 47.9 \text{ dB} \quad (2-19)$$

The measured SNR under these conditions varied between 47 and 48 dB. The calculated SNRs agree well with the measured SNRs for IF SNRs between approximately 12 and 20 dB. This is illustrated in Figure 2-114. At higher IF SNRs, other sources of noise are also significant. The maximum PAM output SNR was approximately 60 dB for the hardware and test parameters used in this test. At IF SNRs below 12 dB, the noise at the input to the PAM demodulator includes “pop” noise; therefore, the SNR is much lower than predicted by the equations. The PAM demodulator also has trouble keeping track of the proper time to sample the signal. The PAM output SNR decreased by 3 dB when the IF SNR decreased from 15 to 12 dB, by 9 dB when the IF SNR decreased from 12 to 9 dB, and by 15 dB when the IF SNR decreased from 9 to 6 dB.

The PAM output SNR is also lower for signals near 0 percent or 100 percent of full scale than for signals near 50 percent of full scale when the IF SNR is below 12 dB. This is shown in Figure 2-115. There are two main reasons for this degradation:

- a. The number of noise pops is proportional to the difference between the signal frequency and the average noise frequency.
- b. The receiver IF filter usually attenuates signals deviated towards band edge more than signals in the center of the bandpass.

The receiver bandpass filter used for the data shown in Figure 2-115 was skewed towards a frequency higher than the center frequency, and as a result, the average noise frequency was between 50 percent and 100 percent of full scale. This skewing caused the 0 percent full scale signal to have the most noise pops and the lowest SNR.

Sample unfiltered PAM demodulator output noise time domain plots are presented in Figure 2-116 through Figure 2-124. In these figures, the PAM channel rate was 25 kCh/s, the peak deviation was 125 kHz, and the receiver IF bandwidth was approximately 640 kHz. These figures show the increase in noise as the IF SNR is decreased. Figure 2-121 shows the effects of the average noise frequency being higher than the receiver center frequency. The largest noise spikes in Figure 2-121 go towards 100 percent of full scale. The reason is that the average noise frequency is greater than the 50 percent full scale signal frequency. Figure 2-122 through Figure 2-124 show the effects of noise on a triangular modulation signal for IF SNRs of 12, 9, and 6 dB.

The calculations presented above assume that there is no additional filtering at the channel outputs of the PAM decommutator. The noise consists of a series of pulses with duration equal to the time between samples of the signal being monitored and amplitude equal to the error between the actual output and the correct value. The normalized power is equal to the rms error squared. This produces a noise power spectrum that takes the form of

$$k \sin^2(\pi f/f_s) / (\pi f/f_s)^2$$

where f_s is the sampling rate of the signal and k is proportional to the rms error squared.

We can now calculate the S/N at the output of a low-pass filter following the raw decommutated output (output gate). The filter improvement was calculated by numerically integrating the product of the noise power spectrum and the filter response. See Table 2-9 for a 4-pole Bessel filter and an I-pole RC filter for various filter cutoffs relative to the sample rate.

| TABLE 2-9. SNR IMPROVEMENT FOR VARIOUS LOW-PASS FILTERS AFTER DECOMMUTATED OUTPUT (COMPARED TO RAW DECOMMUTATED OUTPUT). | | |
|---|----------------------|-----------------------------|
| SAMPLE RATE/ | | SNR IMPROVEMENT (dB) |
| FILTER CUTOFF | 4-POLE BESSEL | I-POLE RC |
| 1 | 0.7 | 0.7 |
| 5 | 4.1 | 3.65 |
| 10 | 6.9 | 5.9 |
| 20 | 9.8 | 8.5 |
| 40 | 12.7 | 11.3 |

Measured improvements were within 0.5 dB of the values in Table 2-9 for IF SNRs above 8 dB. Table 2-9 data shows that if we sample a function 1000 times per second and use a 100 Hz RC filter on the output, we reduce the noise by nearly 6 dB compared to no filter.

2.7.5 Other Sources of Error in PAM. There are several other sources of error (differences between source signal and decommutated output) in a PAM system. These sources are usually insignificant at low IF SNRs but may be dominant at high IF SNRs. The sources include:

- a. Incidental FM in either transmitter or receiver
- b. Nonlinearities in either transmitter modulator or receiver demodulator
- c. Crosstalk with adjacent PAM channels
- d. Tape recorder flutter
- e. Crosstalk with other signals modulating the same transmitter
- f. Gain and offset errors in the vehicle signal conditioner
- g. Noise in the vehicle instrumentation package, telemetry receiver, or PAM decommutator.

Because of the many sources of error, PAM systems are usually specified to have absolute accuracies between 2 and 5 percent of full scale.

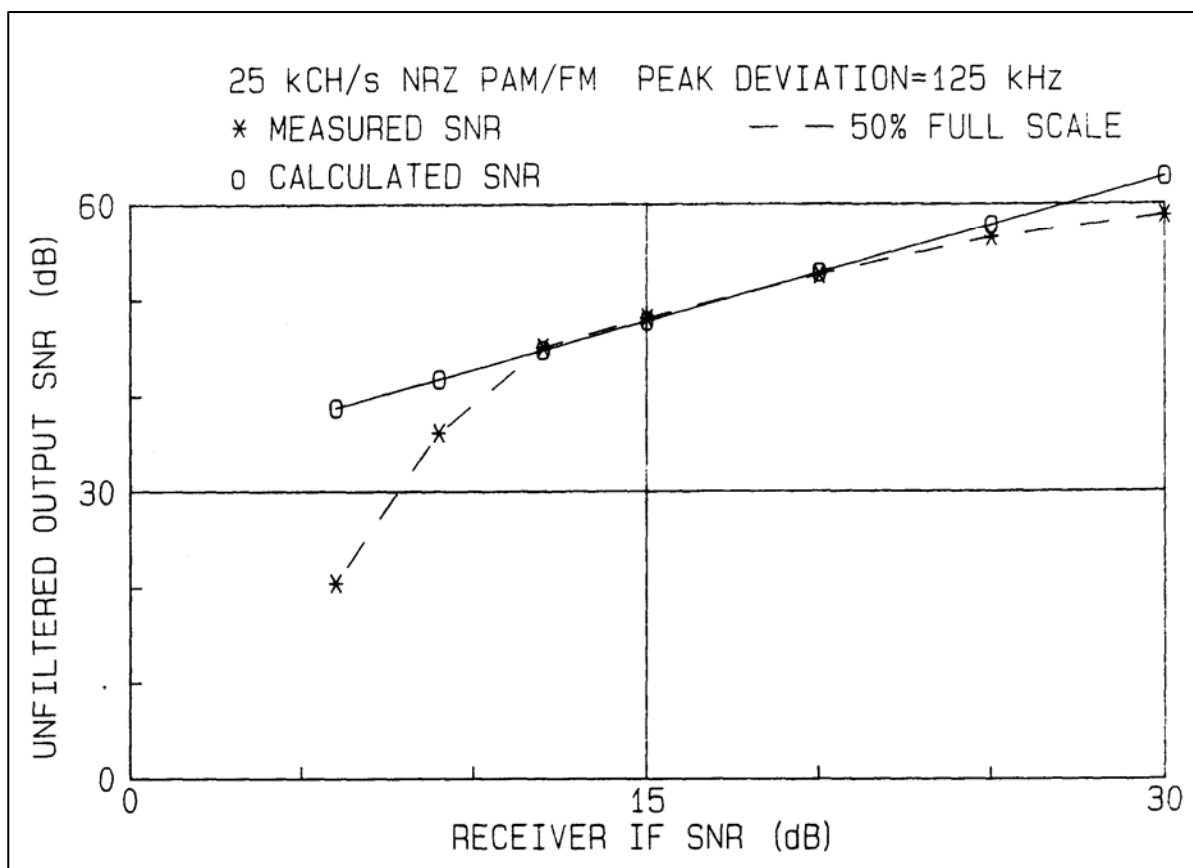

Figure 2-114. Measured and Calculated PAM Output SNR Versus IF SNR.

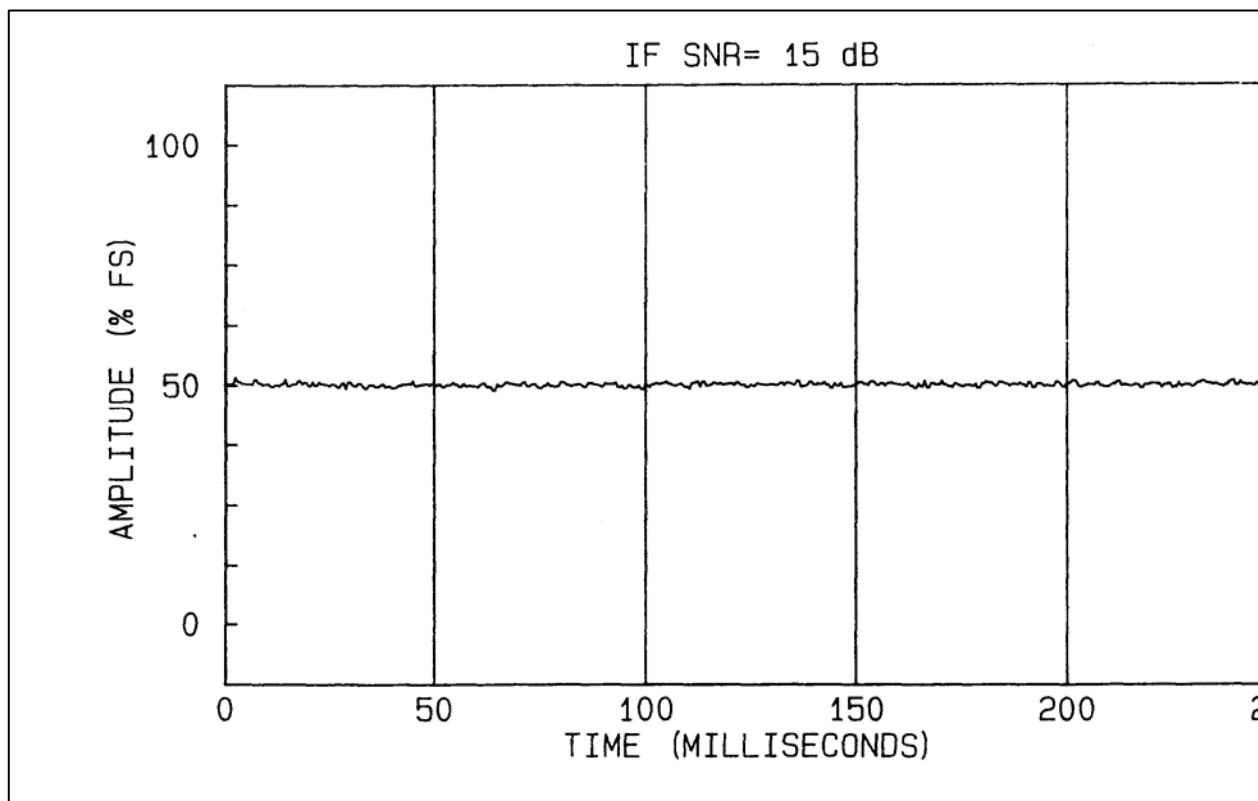

Figure 2-116. PAM DECOM Output for 15 dB IF SNR with 50% FS Modulation.

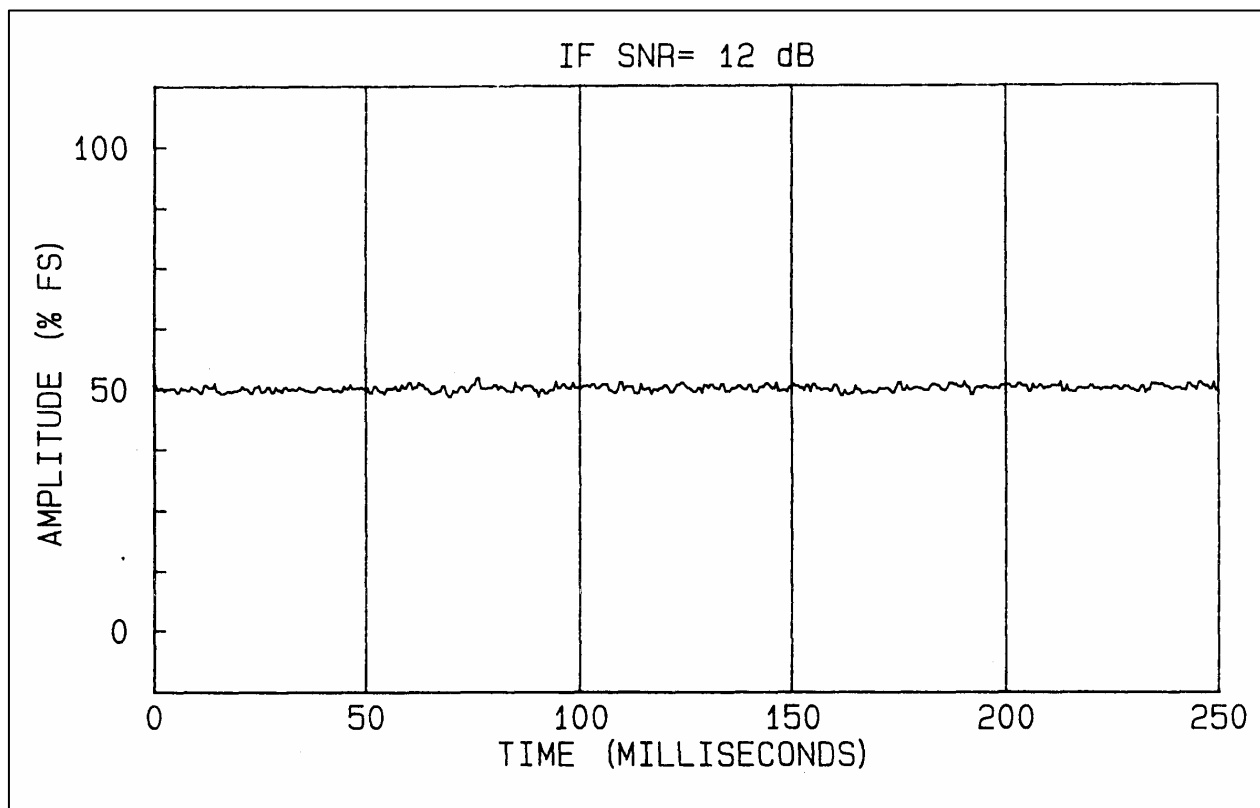

Figure 2-117. PAM DECOM output for 12 dB IF SNR with 50 percent FS modulation.

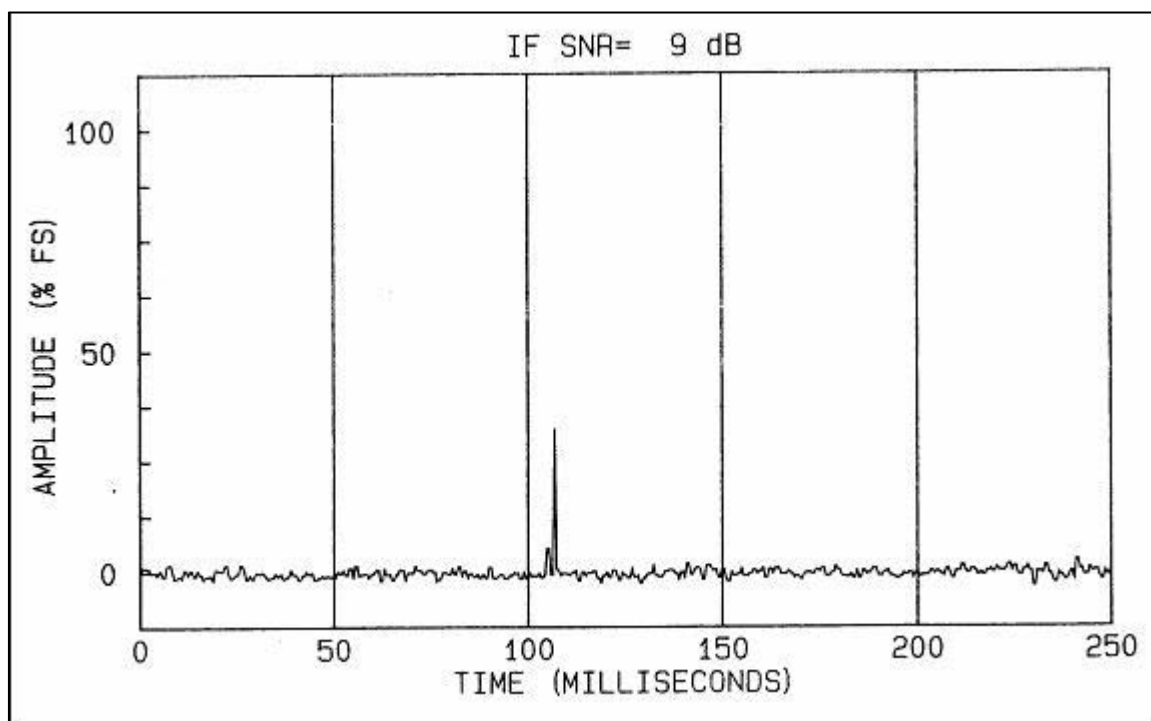

Figure 2-118. PAM DECOM output for 9 dB IF SNR with 0 percent FS modulation.

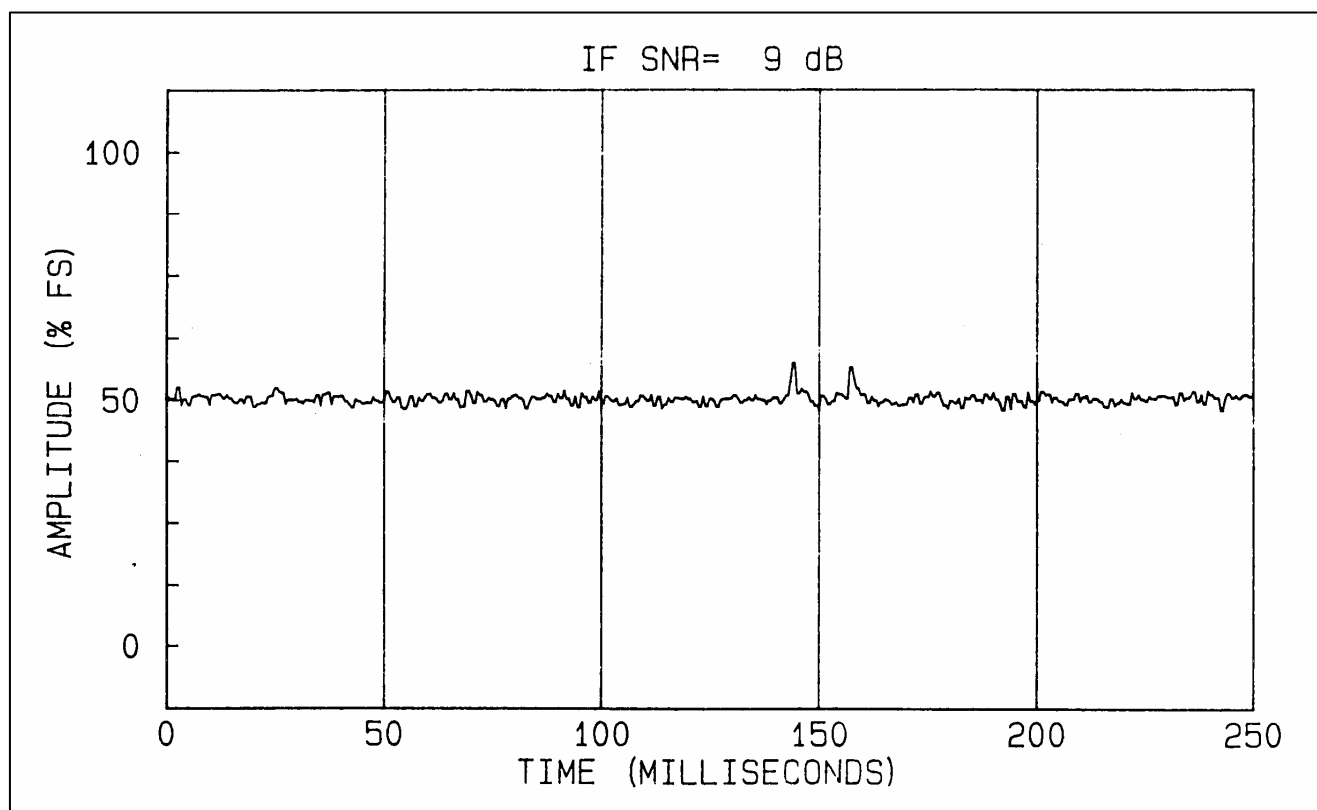

Figure 2-119. PAM DECOM output for 9 dB IF SNR with 50 percent FS modulation.

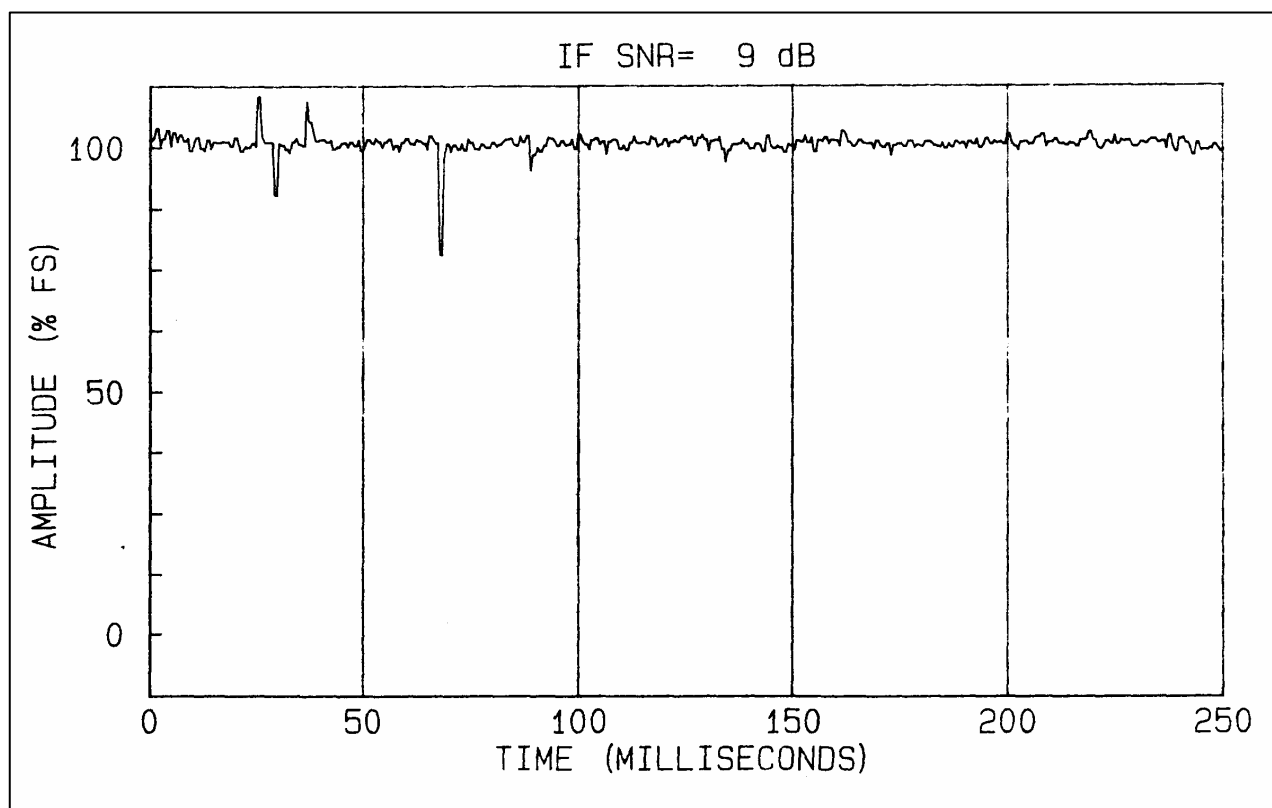

Figure 2-120. PAM DECOM output for 9 dB IF SNR with 100 percent FS modulation.

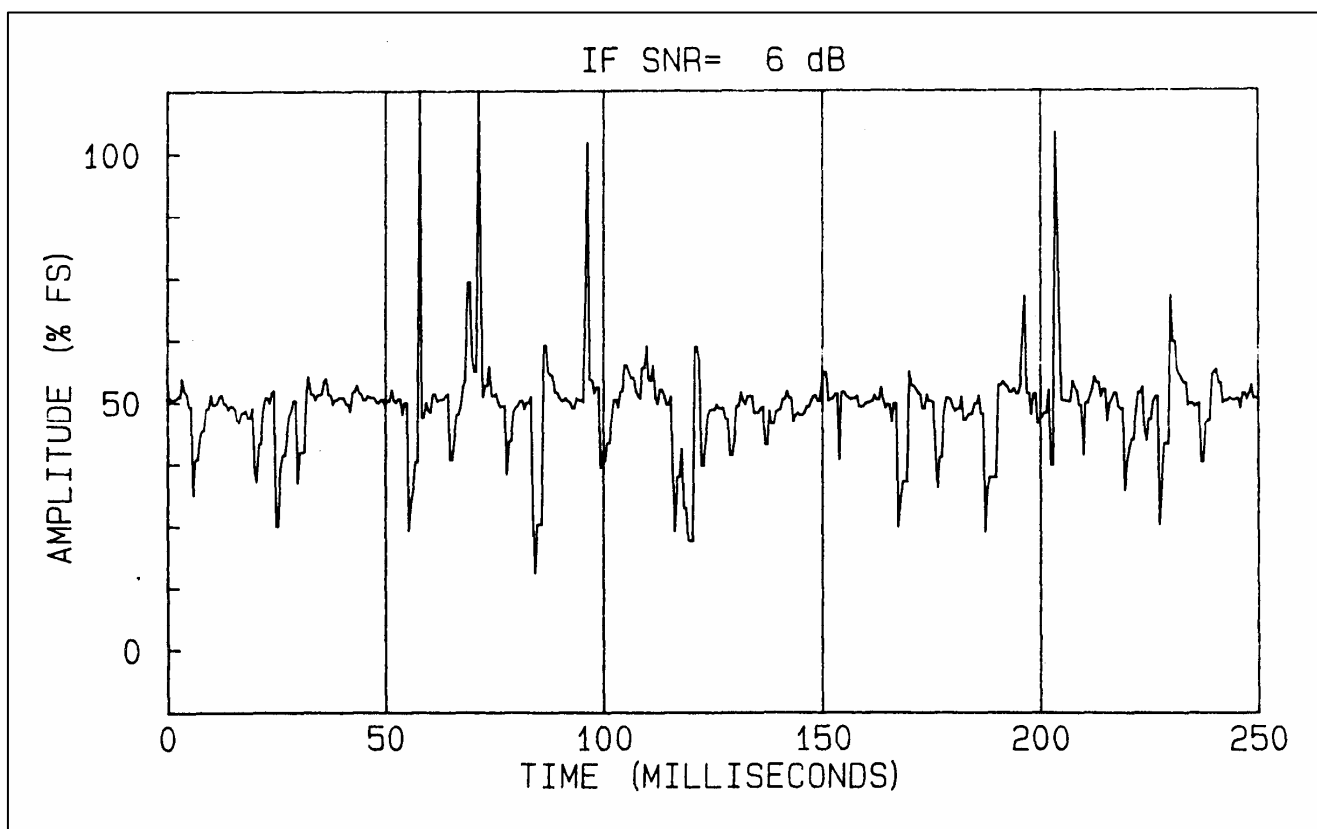

Figure 2-121. PAM DECOM output for 6 dB IF SNR with 50 percent FS modulation.

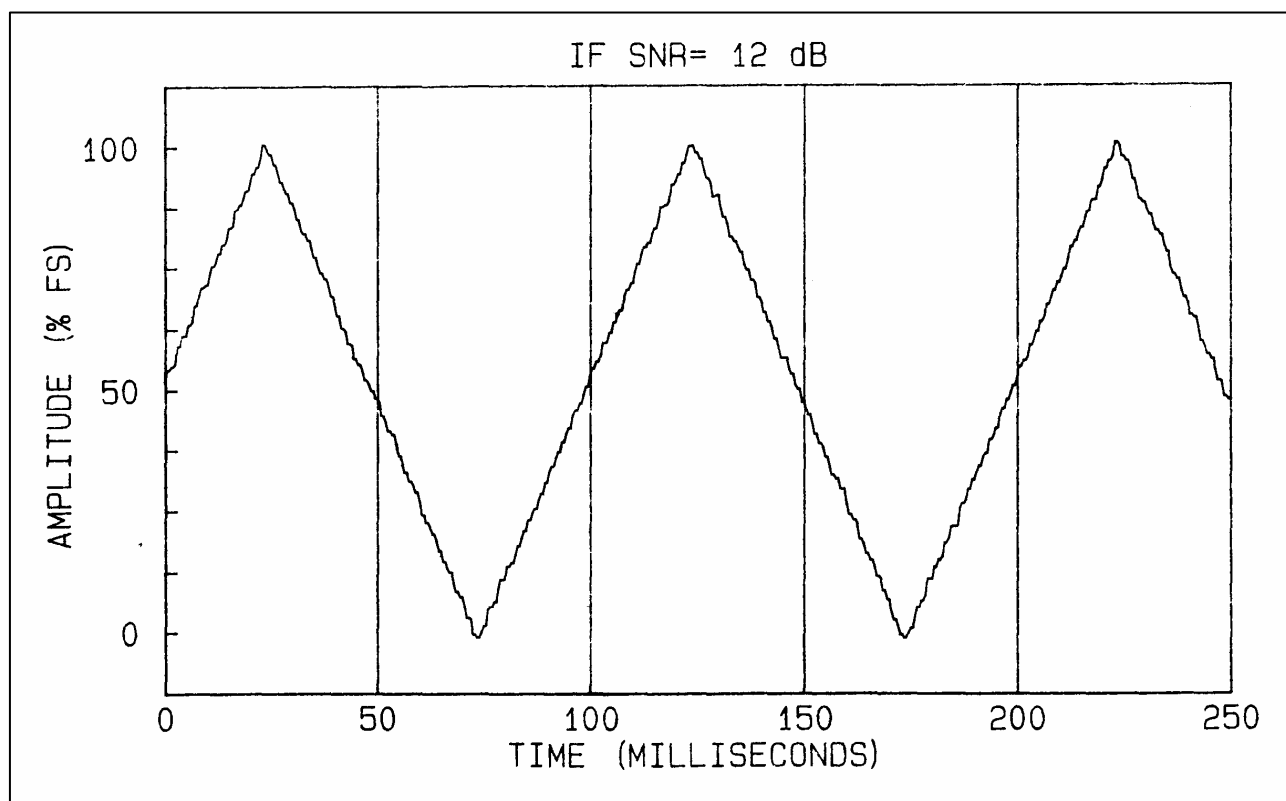

Figure 2-122. PAM DECOM output for 12 dB IF SNR triangle modulation.

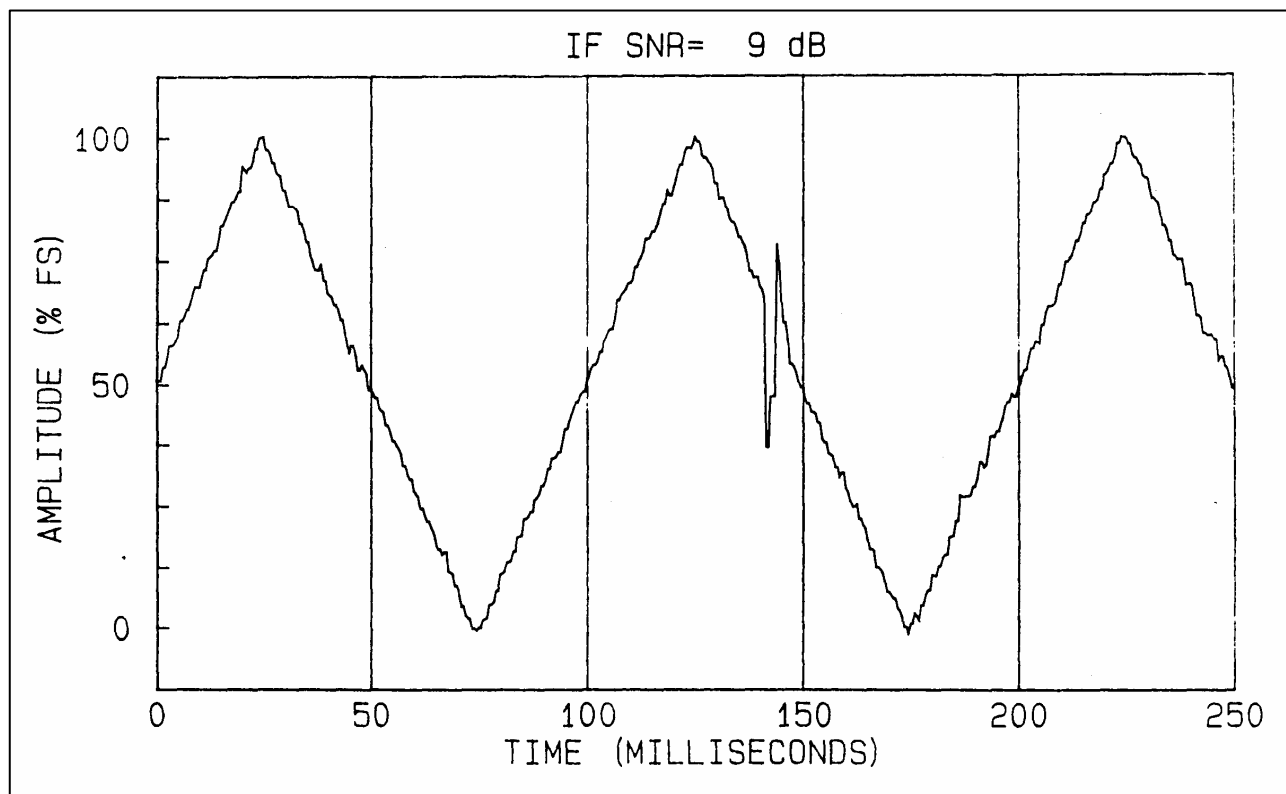

Figure 2-123. PAM DECOM output for 9 dB IF SNR with triangle modulation.

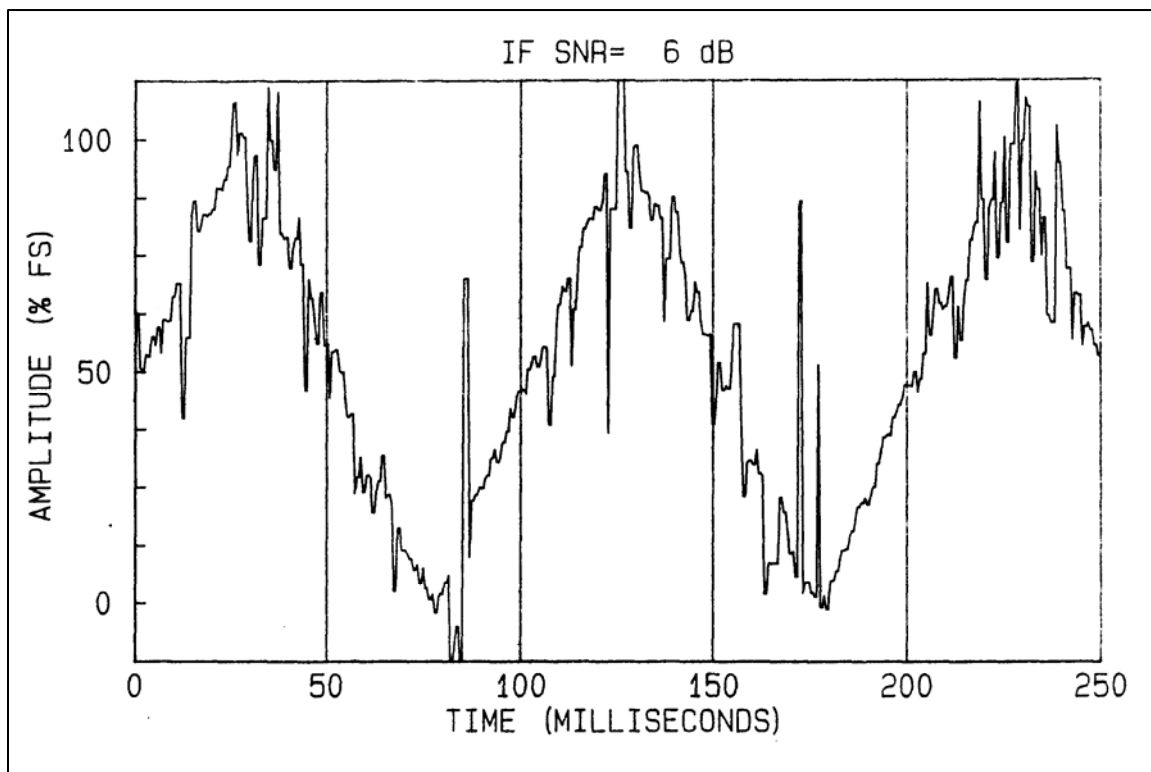

Figure 2-124. PAM DECOM output for 6 dB IF SNR with triangle modulation.

2.7.6 NRZ PAM/FM Receiver IF Filter. The best receiver IF filter bandwidth (-3 dB) will usually be between 1.2 and 1.5 times the RF peak-to-peak deviation as long as the ratio of peak RF deviation to PAM channel rate is greater than 2. If the PAM signal is recorded in a predetection format, the best receiver filter bandwidth will probably be closer to twice the peak-to-peak RF deviation. This will allow the use of a filter on the recorder output of approximately the same bandwidth as the receiver filter. If the received signal is strong enough that the demodulator is always above FM threshold, the data quality will be slightly better with wide IF filters because they will tend to have better phase characteristics in the region the signal occupies; therefore, the step response will be better and the crosstalk less. The disadvantage of wide IF filters is that they pass more noise and FM threshold occurs sooner. The PAM data quality degrades rapidly below FM threshold so it is very desirable to remain above FM threshold. Narrow filters pass less noise, so the instantaneous signal amplitude is more likely to be greater than the instantaneous noise amplitude. However, narrow filters are more sensitive to receiver tuning errors and RF frequency drift. A filter with a -3 dB bandwidth equal to the peak-to-peak RF deviation would also attenuate the signal amplitude by 3 dB when the PAM signal is at either 0 percent or 100 percent of full scale. Therefore, the 0 percent and 100 percent signals would reach FM threshold 3 dB before the mid-scale signals. Since the 0 percent and 100 percent signals are used for calibration of the PAM demodulator, this could also degrade the accuracy of the mid-scale signals.

2.7.7 NRZ PAM/FM Receiver Video Filter. The receiver video filter should be a linear phase filter with bandwidth at least twice the PAM channel rate. This allows the demodulator to perform the filtering of the signal. The receiver video output must be dc coupled because the PAM signal usually contains a large dc component that varies in amplitude.

2.7.8 PAM Baseband Spectra. The baseband NRZ PAM power spectrum has a shape of

$$[\sin^2(\pi f/f_p)] / (\pi f/f_p)^2$$

where

f_p is the PAM channel rate.

The exact spectrum depends on the amplitudes of the individual PAM channels. PAM signals are usually filtered by a 4- to 6-pole linear phase low-pass filter with a -3 dB point of approximately twice the PAM channel rate before they modulate a VCO or transmitter. A sample NRZ PAM baseband spectrum with a 4-pole filter is illustrated in Figure [2-125](#). A linear phase filter is used to minimize the overshoot, crosstalk between adjacent channels, and the settling time.

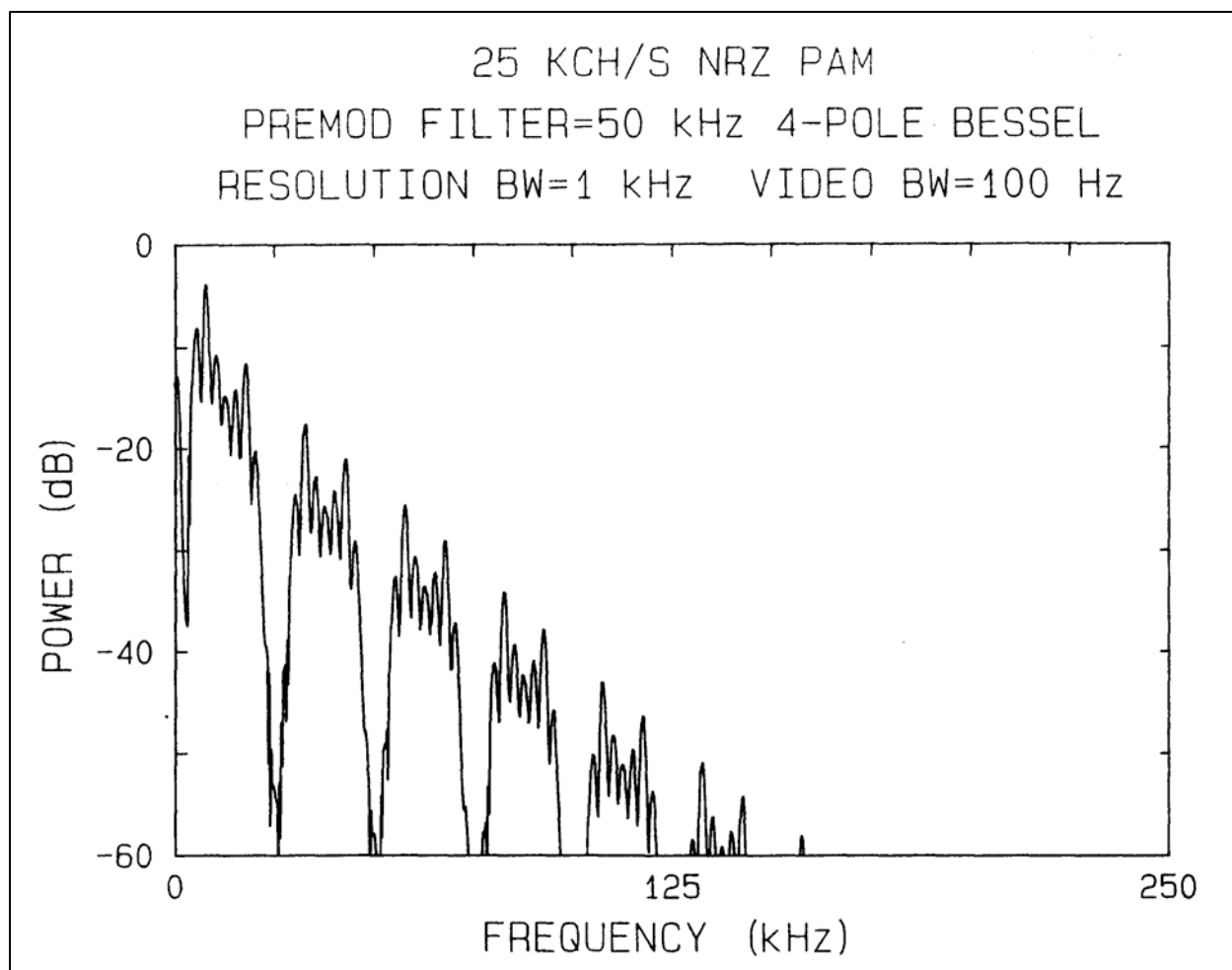

Figure 2-125. NRZ PAM baseband spectrum.

2.7.9 NRZ PAM/FM RF Spectra. The RF spectrum of an NRZ PAM/FM signal depends on the amplitude distribution of the PAM channels, the peak deviation, and the premodulation filter bandwidth. Typical NRZ PAM/FM spectra are illustrated in Figure 2-126, Figure 2-127, and Figure 2-128 for 25 kCh/s PAM with a 50 kHz 5-pole linear phase premodulation filter and peak deviations of 50, 125, and 250 kHz. Figure 2-129 presents the spectra of the signal in Figure 2-127 with the premodulation filter removed. In comparing these two figures, we discover that the bandwidth that contains most of the energy is approximately 275 kHz in both figures, but the -60 dBc bandwidth is much greater without a premodulation filter. Figure 2-130 shows the RF spectrum of a 50 kCh/s NRZ PAM/FM signal with a peak deviation of 125 kHz and a premodulation filter bandwidth of 100 kHz.

The bandwidth that contains most of the signal energy is approximately

$$2 (\text{peak deviation} + \text{PAM rate}/2).$$

The bandwidth beyond which all signals are 60 dB below the unmodulated carrier with a 4 to 6-pole linear phase premodulation filter with -3 dB bandwidth equal to twice the PAM rate is approximately

$$2.5 (\text{peak deviation} + 3 \text{ PAM rate}).$$

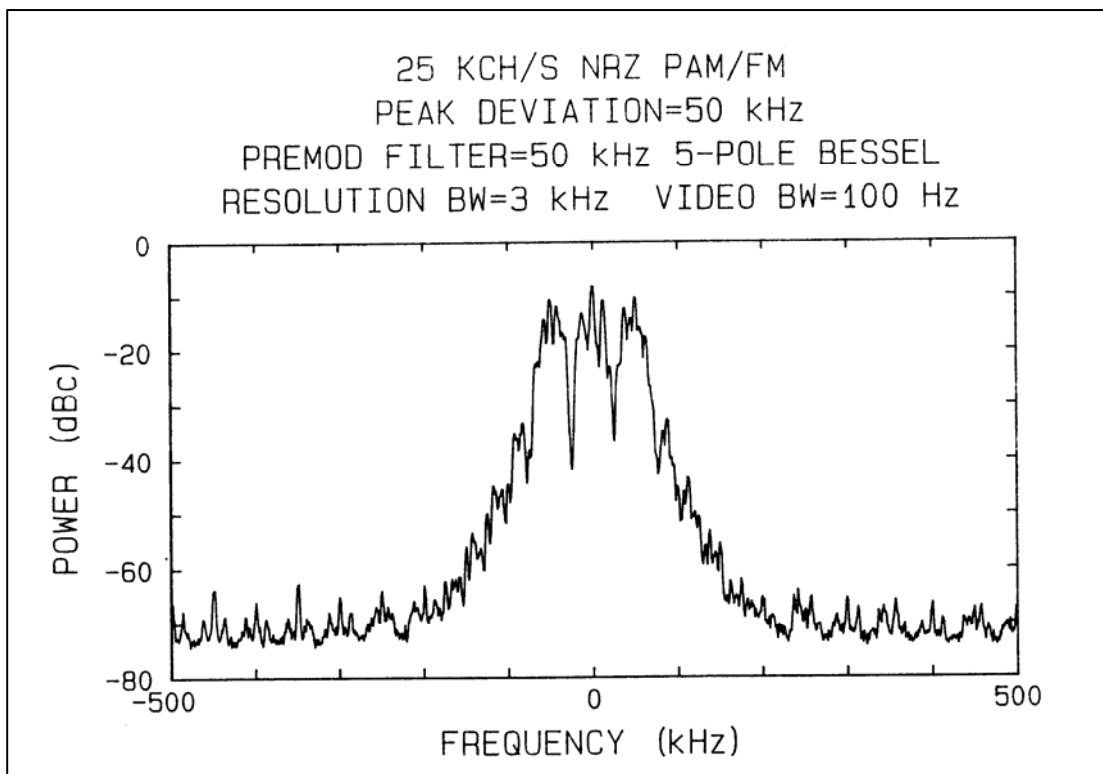

Figure 2-126. PAM/FM RF spectrum with peak deviation = 50 kHz.

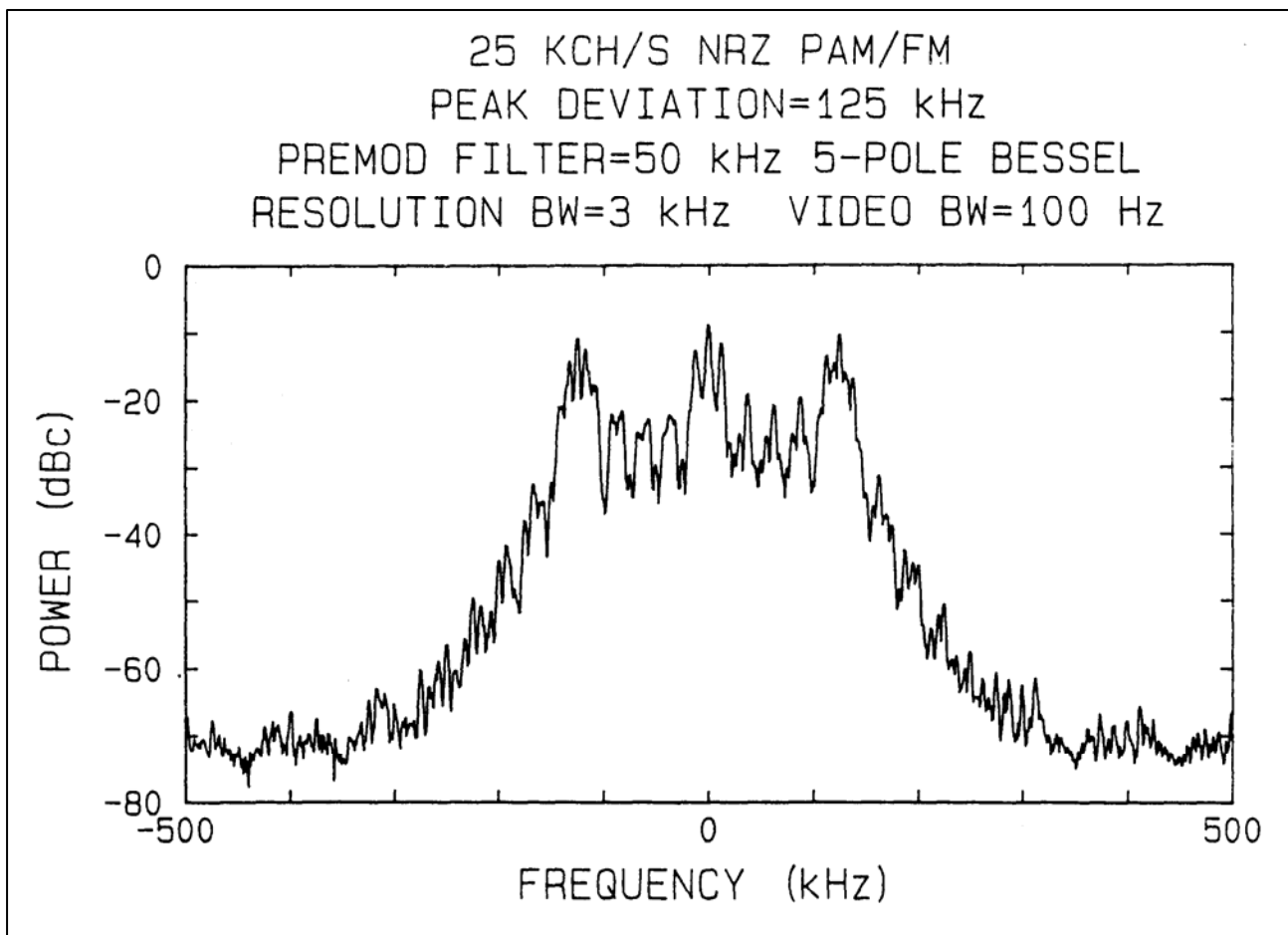

Figure 2-127. PAM/FM RF spectrum with peak deviation = 125 kHz.

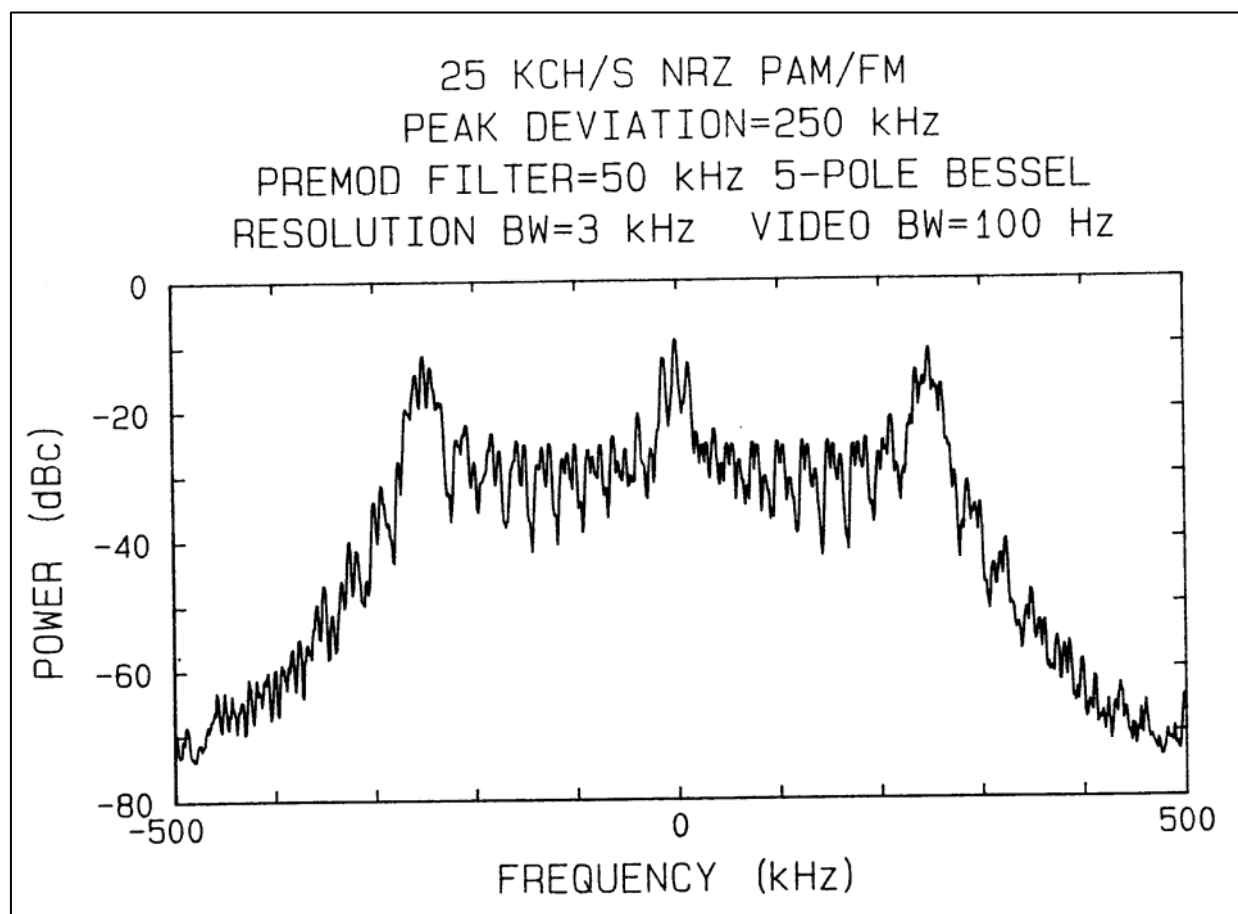

Figure 2-128. PAM/FM RF spectrum with peak deviation = 250 kHz.

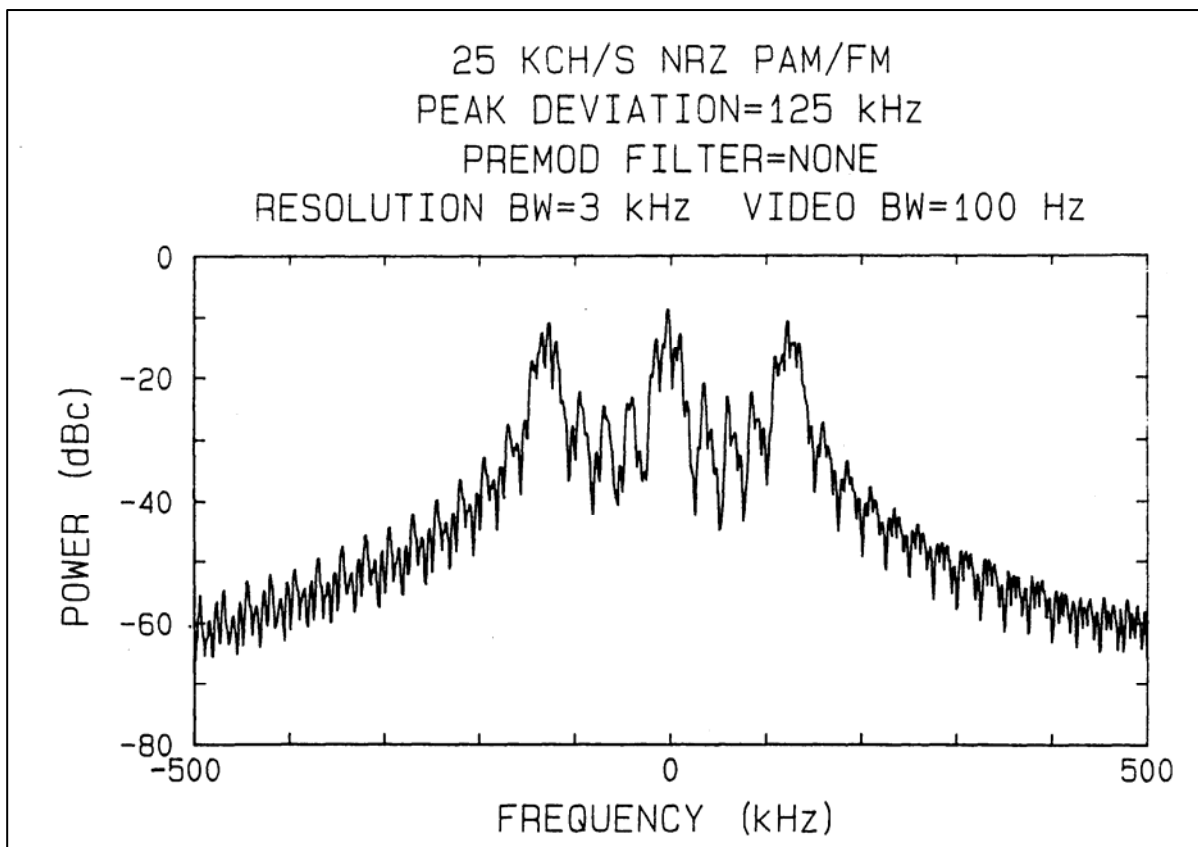

Figure 2-129. PAM/FM RF spectrum with No Premodulation Filter.

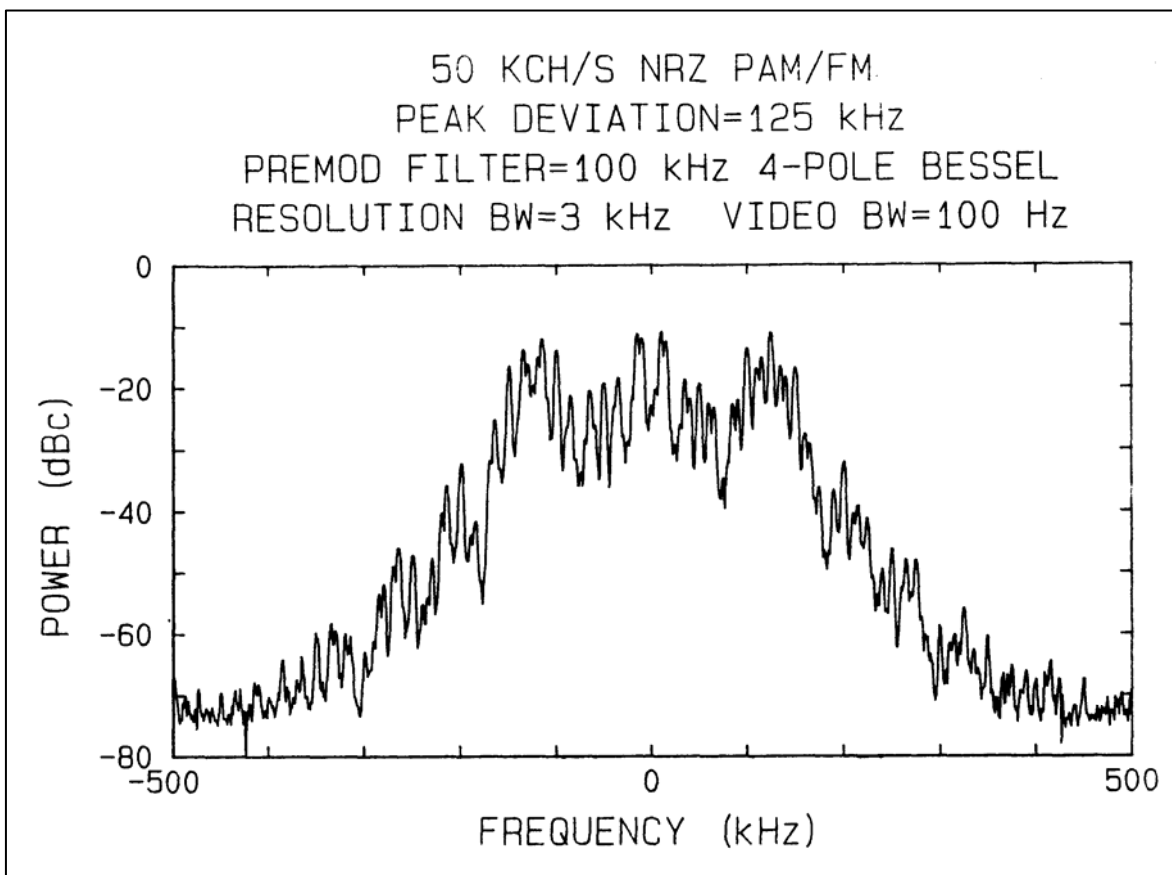

Figure 2-130. 50 kCH/s PAM/FM RF spectrum.

2.8 FM/FM Telemetry

2.8.1 Introduction. A typical FM/FM system block diagram is presented in Figure 2-131. The transmitting system consists of several SCOs, which are at different, compatible frequencies. A list of Inter-Range Instrumentation Group (IRIG) standard SCO frequencies is contained in the current issue of the Telemetry Standards. The 1986 Telemetry Standards (IRIG 106) includes constant bandwidth (CBW) SCOs with center frequencies between 16 and 1024 kHz and peak deviations from 2 to 128 kHz and proportional bandwidth (PBW) SCOs with center frequencies between 400 Hz and 560 kHz with peak deviations of 7.5 percent, 15 percent, and 30 percent (the frequencies below 22 kHz are only used with 7.5 percent peak deviation). Because the SCO operates as a linear voltage-to-frequency converter, the output frequency minus the SCO center frequency will be proportional to the input voltage. The center frequencies and deviation limits of the SCOs should be chosen to be compatible with the bandwidths of the input data signals, the available radio frequency (RF) spectral bandwidth, and the receiving equipment. The nominal IRIG deviation ratio is five. Deviation ratio is defined as the ratio of the maximum allowable subcarrier peak deviation to the discriminator low-pass cutoff frequency.

2.8.2 FM/FM SNR. The SNR at the output of an FM demodulator will be discussed in this section. The signal and noise power at the output of an FM demodulator well above FM threshold can be described by the equations

$$S_i = \frac{(K_d)^2 (\Delta f_{si})^2}{2}, \quad (2-20)$$

and

$$N(f) = \frac{2(K_d)^2 G(f) f^2}{A^2}, \quad (2-21)$$

where

| | | |
|-----------------|---|--|
| S_i | = | Signal at FM demodulator output |
| $N(f)$ | = | Noise spectrum at FM demodulator output |
| $A^2/2$ | = | Signal power at FM demodulator input |
| $G(f)$ | = | Noise power spectral density at FM demodulator input |
| K_d | = | Discriminator gain constant |
| Δf_{si} | = | Peak deviation of i^{th} subcarrier. |

Note: The noise power spectral density is proportional to the square of the frequency.

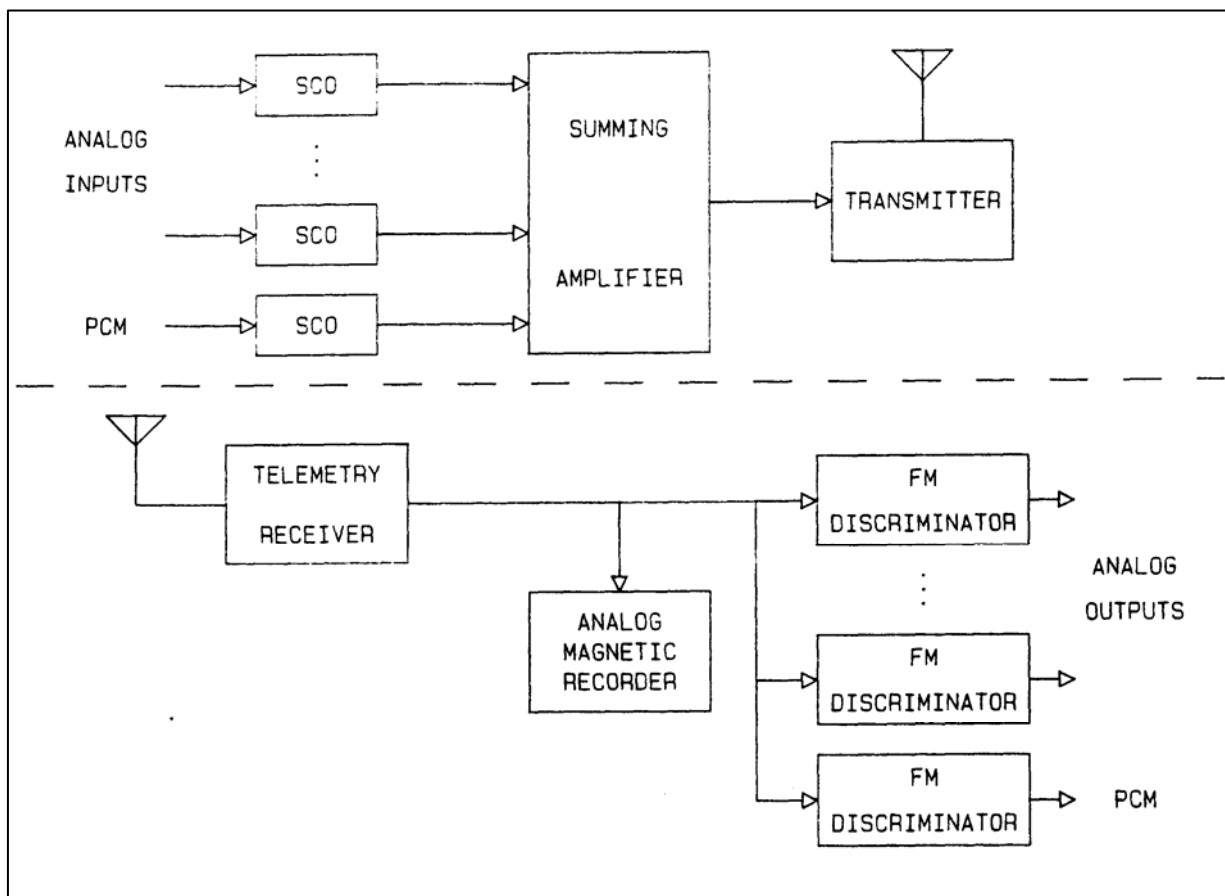

Figure 2-131. FM/FM system block diagram.

The following equations have been presented by several authors (See References [2cc](#), [2dd](#), [2ee](#), and [2ff](#)).

The SNR (power ratio) at the output of an ideal low-pass filter can be shown to be

$$(S/N)_{LPF} = \frac{3(\Delta f_i)^2 B_{IF} (S/N)_{IF}}{2(f_c)^3}, \quad (2-22)$$

where

$(S/N)_{IF}$ is the IF SNR

B_{IF} is the IF bandwidth

f_c is the low-pass filter bandwidth.

Δf_i is the peak RF deviation of the i^{th} subcarrier.

The SNR at the output of an ideal bandpass filter can be approximated by

$$(S/N)_{BPF} = \frac{(\Delta f_i)^2 B_{IF} (S/N)_{IF}}{2(f_i)^2 B_i}, \quad (2-23)$$

where

f_i is the center frequency of the subcarrier

B_i is the bandwidth of the subcarrier discriminator bandpass filter.

These two equations can be used to calculate the approximate SNR of any FM signal.

The SNR (power ratio) at the output of a subcarrier discriminator can be calculated by substituting the SNR at the output of the bandpass filter for the SNR_{IF} and the subcarrier IF bandwidth for the receiver IF bandwidth in the lowpass filter case

$$SNR_{di} = \frac{3(\Delta f_i)^2 (\Delta f_{si})^2 B_{IF} SNR_{IF}}{4(f_i)^2 (f_c)^3}. \quad (2-24)$$

This SNR is the ratio of the power in a full scale sine wave to the noise power. To convert this to rms noise relative to full scale signal, multiply the previous equation by 8 and take the square root, which gives this equation

$$SNR_v = \frac{2.45(\Delta f_i)(\Delta f_{si})(B_{IF} SNR_{IF})^{1/2}}{f_i (f_c)^{3/2}} \quad (2-25)$$

Equation 2-24 will be used in this report. It allows direct comparisons with PAM and PCM data quality. This equation appears to imply that the output SNR is a function of BIF. However, SNR_{IF} is inversely proportional to the IF bandwidth, so the B_{IF} term cancels out.

2.8.2.1 Assumptions. The major assumptions that were made in deriving these expressions were:

- a. The receiver noise power spectral density (PSD) was constant, and the IF filter gain was constant over the bandwidth B_{IF} and zero everywhere else.
- b. The noise PSD was constant in the discriminator bandpass.
- c. The discriminator bandpass filter gain was constant over the bandwidth B_i and zero everywhere else.
- d. The low-pass output filter gain was constant over the band from zero to f_c and zero everywhere else.
- e. No intermodulation products were introduced in the system.
- f. No interchannel interference was present.
- g. The SNR was high enough that the noise did not capture the demodulator and cause pops.
- h. No other noise sources were present (60 cycle, tape flutter).

2.8.2.2 Accuracy. The accuracy of the preceding assumptions is discussed below.

- a. Assumption a. This assumption affects signal and noise approximately the same and should have no significant effect on SNR.
- b. Assumption b. This assumption is quite good for narrow band channels but not very good for ± 30 -percent channels. The noise at the output of an FM demodulator increases at 6 dB/octave. The noise power/Hz at $0.7 f_i$ is approximately 5.4 dB less than at $1.3 f_i$; however, this does not significantly affect performance above FM threshold. If the subcarrier discriminator reached FM threshold before the receiver discriminator, it could cause the majority of noise pops to be towards higher frequency because the average noise frequency would be greater than the discriminator center frequency.
- c. Assumption c. This assumption has little effect at high deviation ratios (greater than 2) above FM threshold. At a deviation ratio of 1, a modulating signal with a frequency equal to the low pass filter cutoff will be attenuated by 6 dB (3 dB because of BPF, 3 dB because of LPF) while the noise may only be attenuated by 1 dB (3- or 4-pole filters). The discriminator bandpass filter will attenuate a lower band edge or upper band edge signal by approximately 3 dB. Therefore, a signal at band edge will reach FM threshold sooner and have more noise below FM threshold than a signal at band center. This is illustrated in Figure [2-132](#).
- d. Assumption d. This assumption is fairly good for 7-pole Butterworth filters with the -3 dB point at the listed cutoff. Some discriminators use 3-pole Butterworth filters with the -0.5 dB point at the listed cutoff. This causes approximately 6.5 dB more noise power at high deviation ratios (3 or greater). Bessel filters typically pass 3-4 dB more noise than the theoretical brickwall filter. The effects of low-pass filter type and number of poles are shown in Figure [2-133](#) through Figure [2-137](#). Reference [2f](#) also includes plots of these errors.
- e. Assumptions c and d. The cumulative filter error varies from 6-7 dB optimistic for a signal at the low-pass cutoff frequency and any Bessel low-pass filter at a high deviation ratio to 1 dB pessimistic for a deviation ratio of 1 and a frequency at less than 1/2 of the low-pass cutoff frequency.

- f. Assumption e. This assumption is fairly good for IF SNRs below 20 dB. At low IF SNRs, the thermal noise tends to swamp the intermodulation distortion. The amount of intermodulation distortion depends on the linearity of the modulator and demodulator and the phase linearity of the receiver IF filter.
- g. Assumption f. This assumption is valid for high deviation ratios (3 or greater) and IF SNRs below 20 dB. For a deviation ratio of 1 and a 40 dB IF SNR, the interchannel interference can be at least 10 dB larger than the noise.
- h. Assumption g. Receiver noise pops should be insignificant for SCO frequencies above 10 kHz with receiver IF SNRs greater than 12 dB. Noise pops are insignificant for all SCO frequencies for receiver IF SNRs greater than 18 dB. The actual onset of FM threshold varies somewhat for different receiver designs. Ignoring noise pops at a 12 dB IF SNR can lead to an optimistic estimate of SNR for low frequency channels. The data in Figure 2-138 show the measured receiver output noise power at a frequency of 5 kHz for peak deviations of 50, 100, 150, and 200 kHz (500 kHz IF bandwidth) and IF SNRs from 8 to 15 dB. This data shows that the measured and calculated noise at a 12 dB IF SNR agreed well when the peak deviation was 50 kHz but the measured noise power increased by approximately 1.5 dB when the peak deviation was increased to 200 kHz. The excess noise because of pops at a 9 dB IF SNR was 4 dB for 50 kHz peak deviation, 8 dB for 100 kHz peak deviation, and 19 dB for 200 kHz peak deviation. The same measurements were also made at a frequency of 100 kHz. The excess noise because of pops with a 9 dB IF SNR and 200 kHz peak deviation was only 1 dB.

The data in Figure 2-139 through Figure 2-144 show both measured and calculated discriminator output SNRs for various test conditions and assumptions. The units of the vertical axes are dB with respect to full scale (dBFS). This is defined as 20 times the logarithm (base ten) of the ratio of the discriminator band edge-to-band edge voltage swing to the rms noise voltage; for example, 20 mV rms noise with 20 V peak-to-peak signal gives 60 dBFS. The modulation inputs to the SCOs were dc levels for these tests. The data in Figure 2-139 and Figure 2-140 show that use of the ideal assumptions predicts SNRs that are 2 to 6 dB too large for IF SNRs between 10 and 15 dB. The data in Figure 2-141 and Figure 2-142 include corrections for all the significant error effects except noise pops. The predicted and measured SNRs agree very well at IF SNRs of 12 and 15 dB. The low frequency channels have a 1 to 2 dB error at a 10 dB IF SNR because of the effects of noise pops. The errors are much larger at lower IF SNRs. This data also shows that the receiver noise pops affect the lower frequency channels much more than the higher channels. The data in Figure 2-143 and Figure 2-144 show that the SNR of a signal at upper band edge is 4 dB lower than a signal at band center for a deviation ratio of one and 1 dB lower for a deviation ratio of four at a 12 dB IF SNR. The large degradation at a deviation ratio of one is caused by the fact that the signal at band edge is attenuated relative to the noise near band center. Overall, the data in Figure 2-139 through Figure 2-144 suggest that use of a 6 dB correction factor (Γ) would provide a conservative estimate of discriminator output SNR for most conditions.

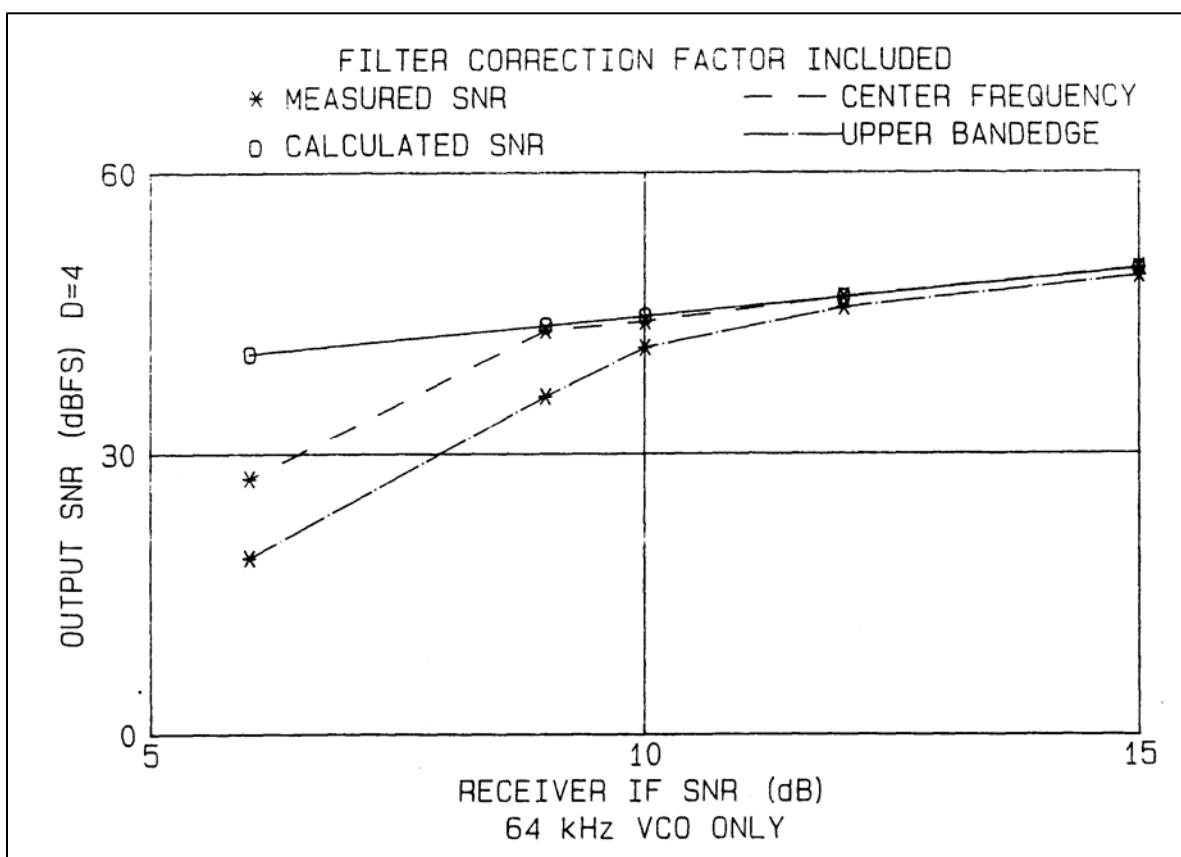

Figure 2-132. FM/FM SNR for center frequency and upper band edge signals.

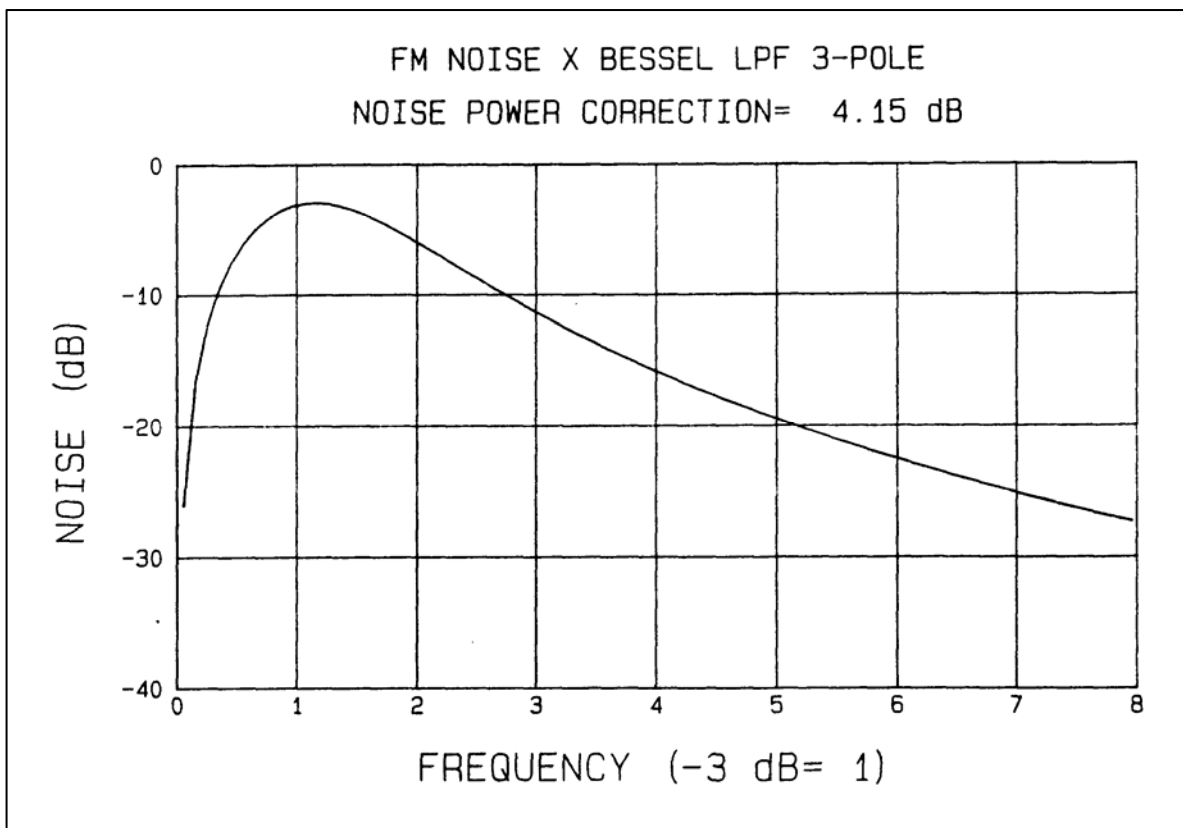

Figure 2-133. FM Noise with 3-pole Bessel LPF.

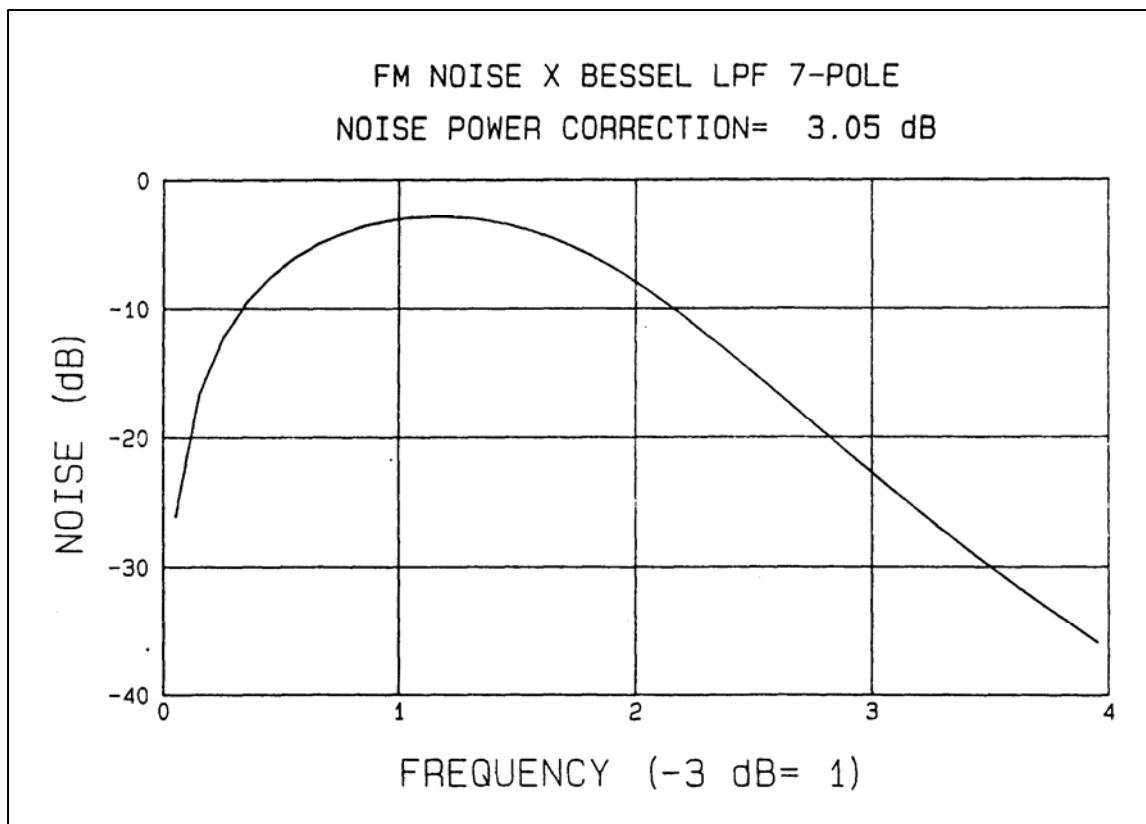

Figure 2-134. FM Noise with 7-pole Bessel LPF.

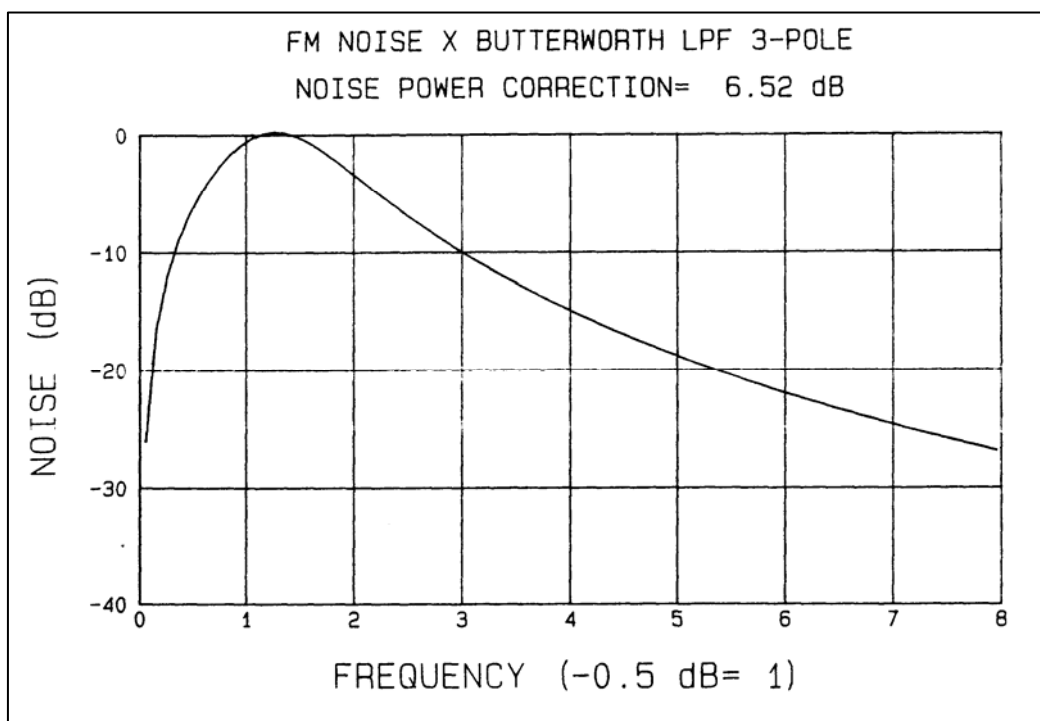

Figure 2-135. FM Noise with 3-pole Butterworth LPF (-0.5 dB).

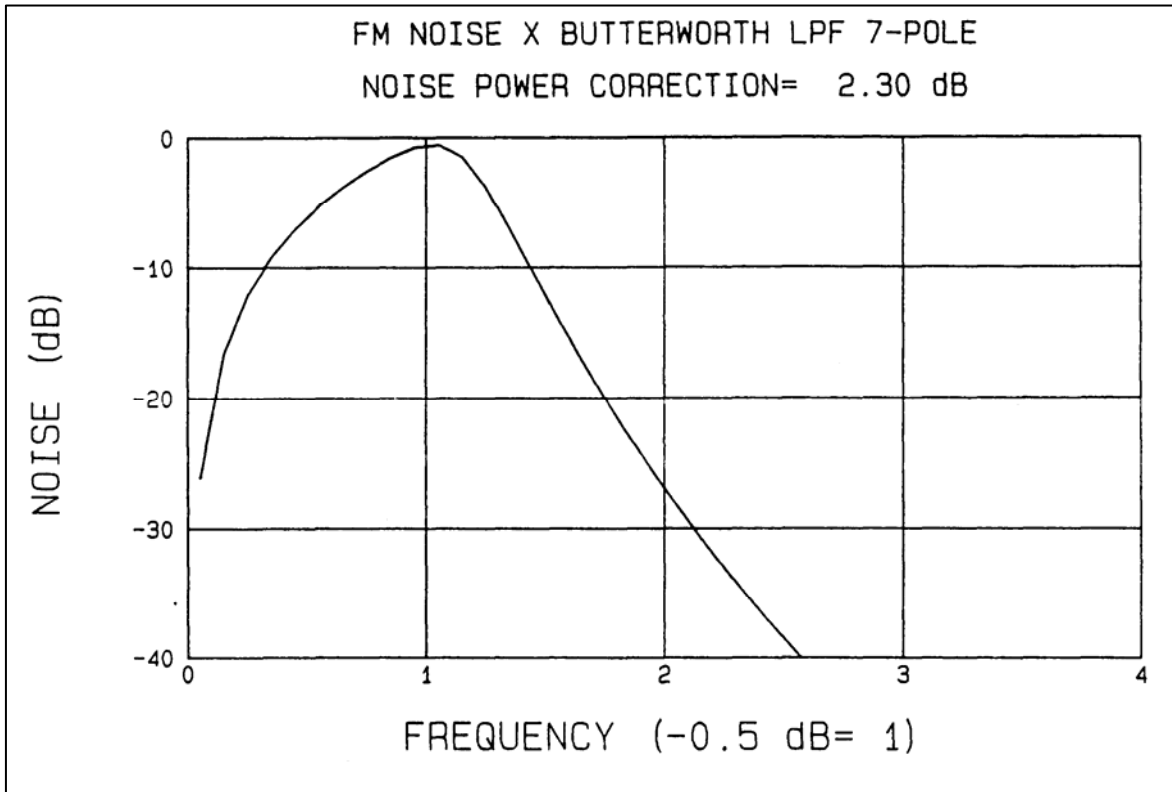

Figure 2-136. FM Noise with 7-pole Butterworth LPF.

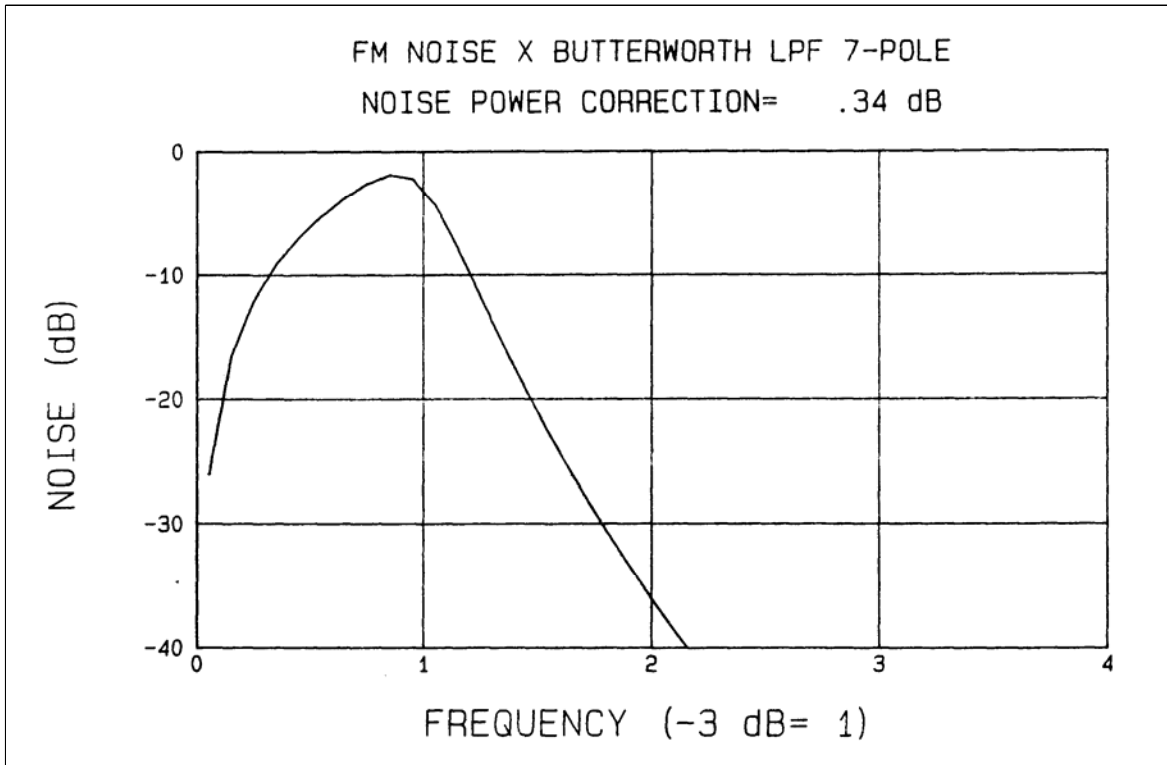

Figure 2-137. FM Noise with 7-pole Butterworth LPF (-3 dB).

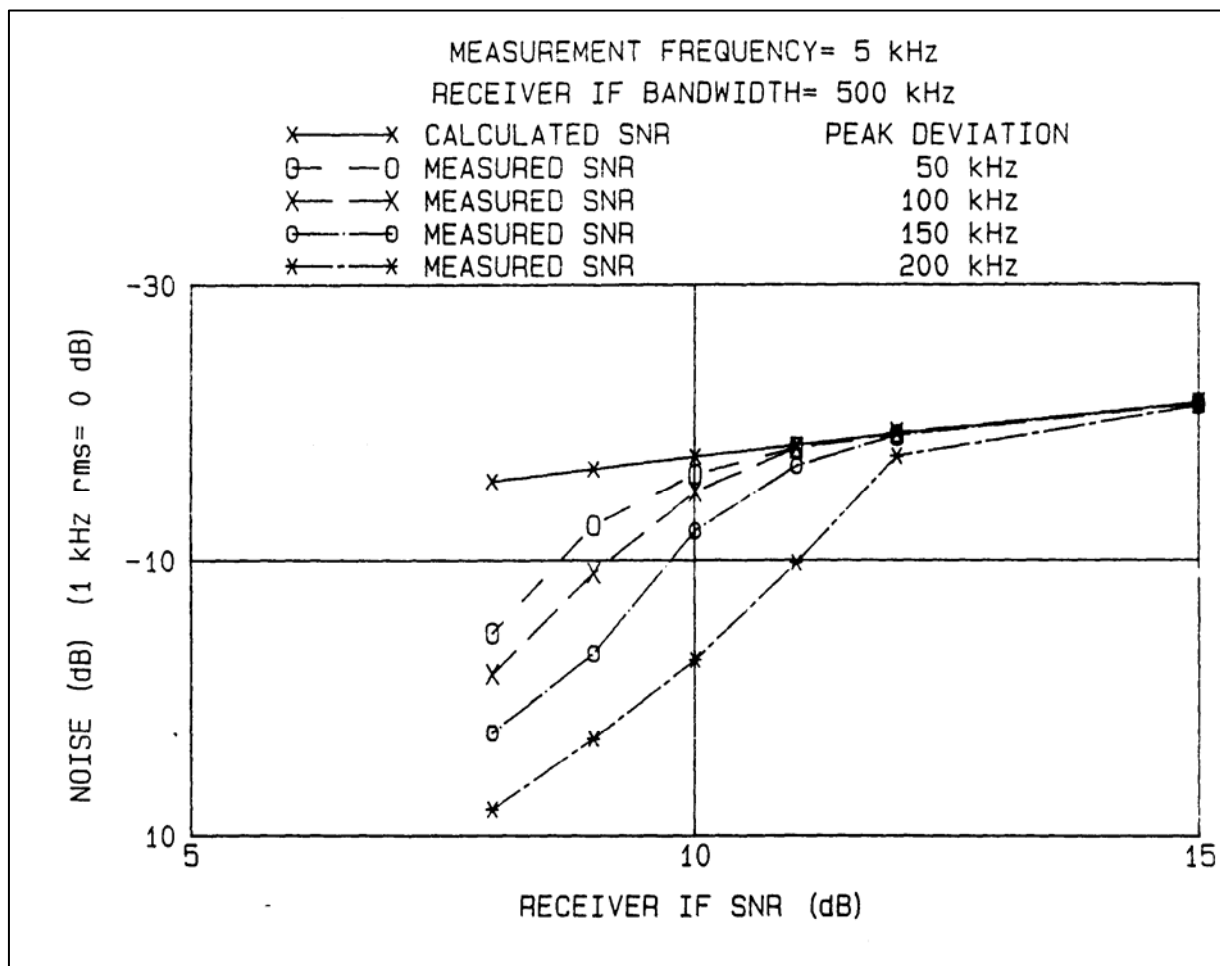

Figure 2-138. FM Noise for several peak deviations.

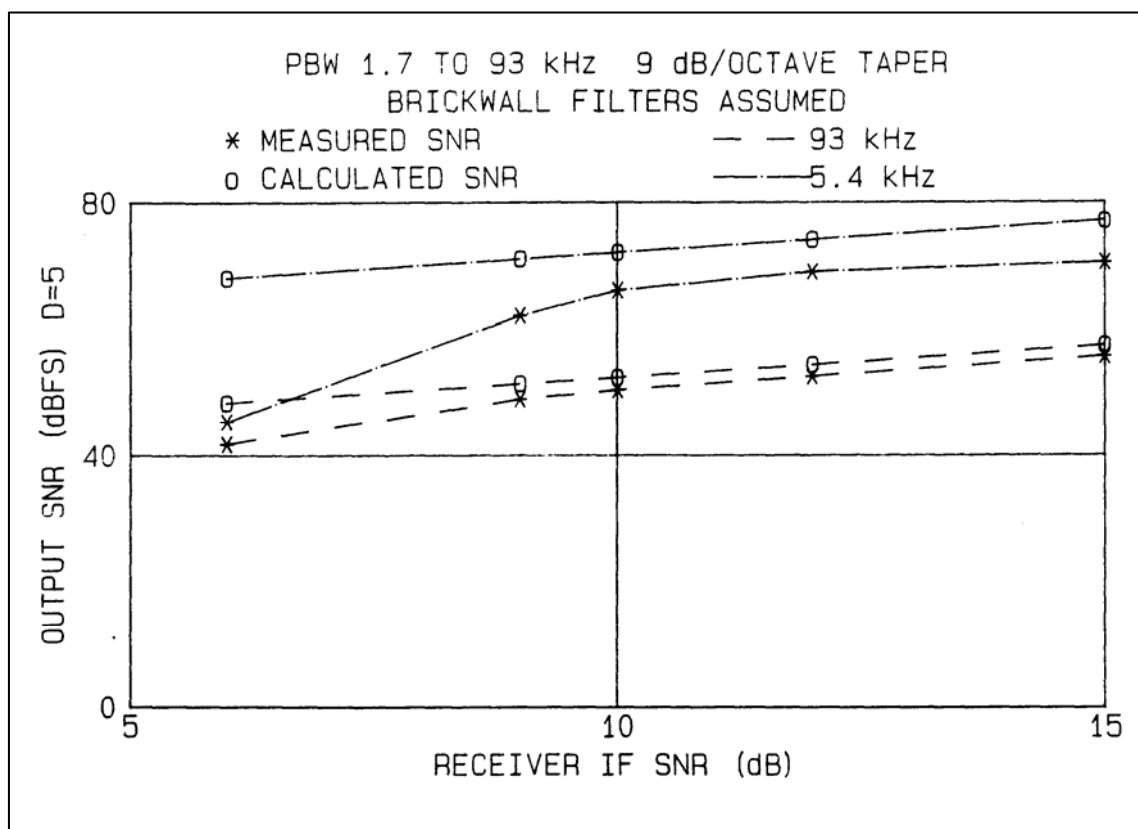

Figure 2-139. PMW measured and calculated SNRs with Brickwall Filters.

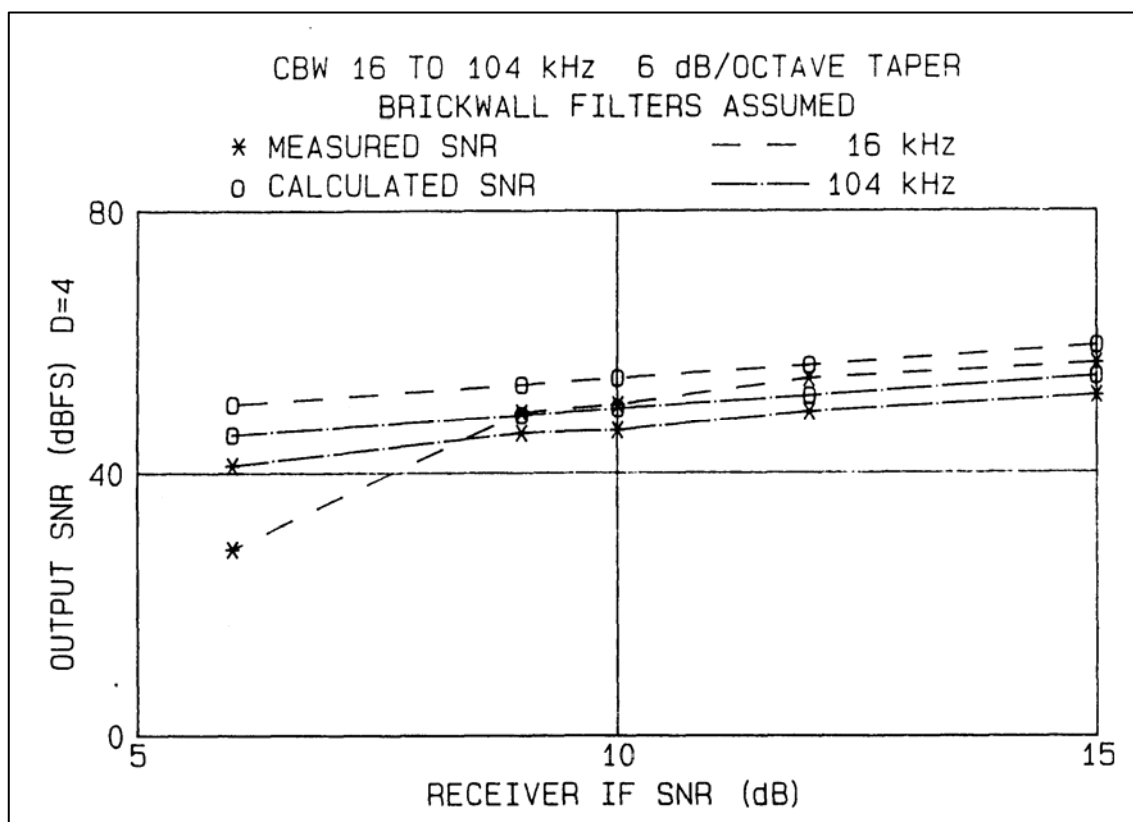

Figure 2-140. CBW measured and calculated SNRs with Brickwall Filters.

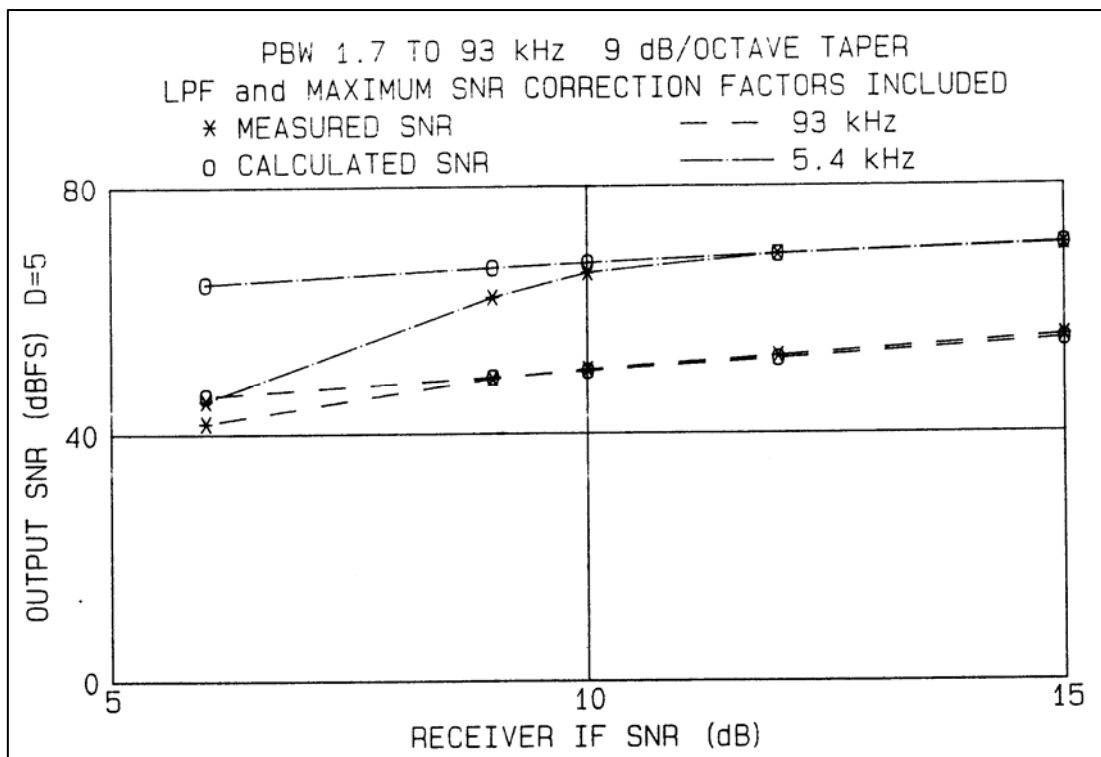

Figure 2-141. PBW measured and calculated SNRs with correction factors.

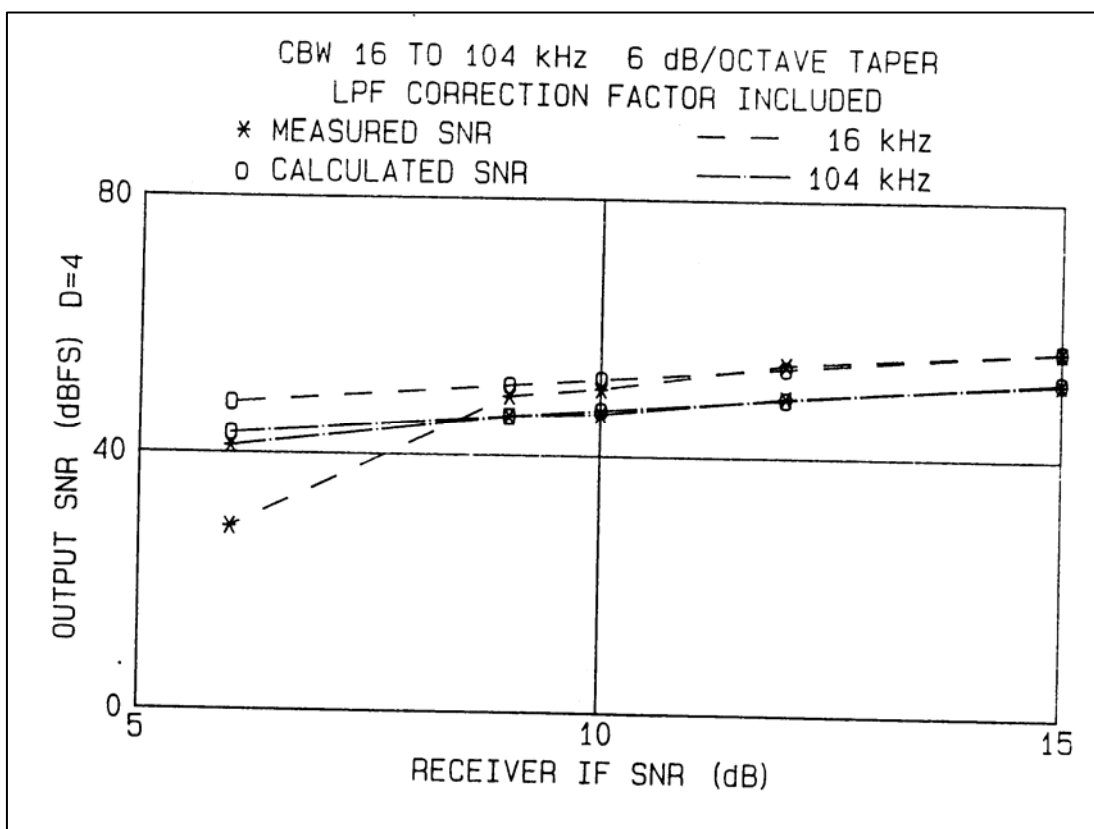

Figure 2-142. CBW measured and calculated SNRs with LPF correction factors.

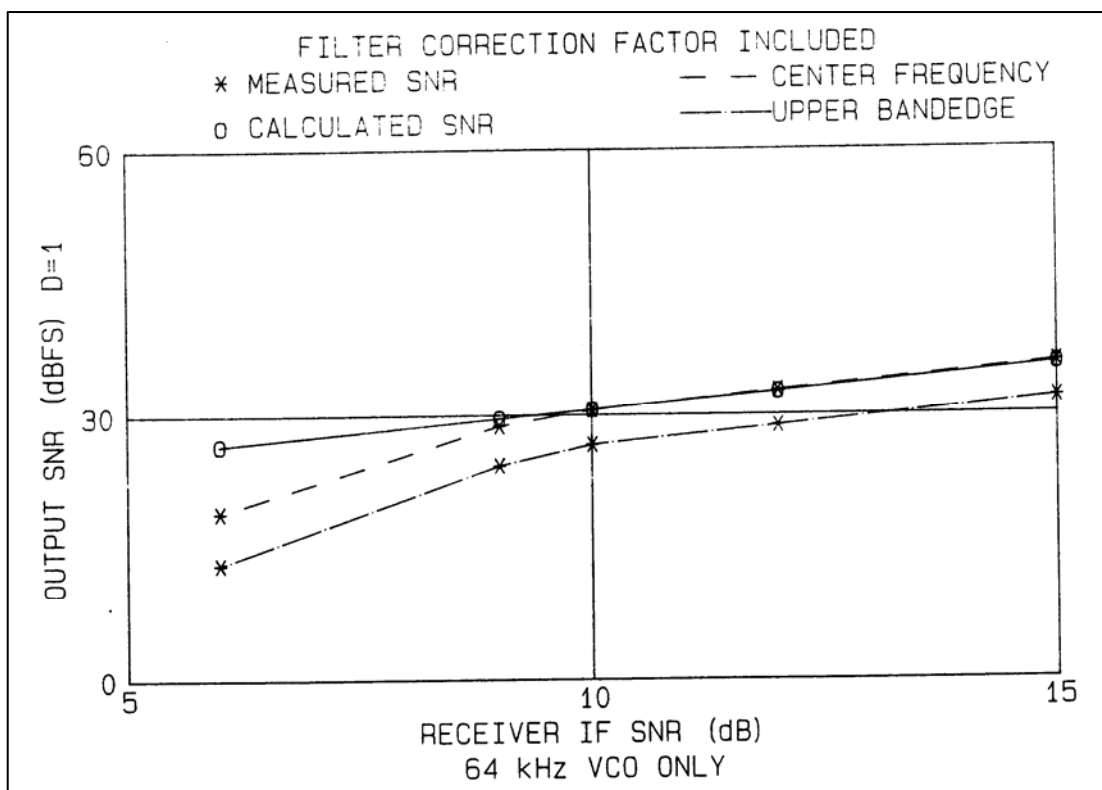

Figure 2-143. Measured and calculated SNRs with correction factors ($D = 1$).

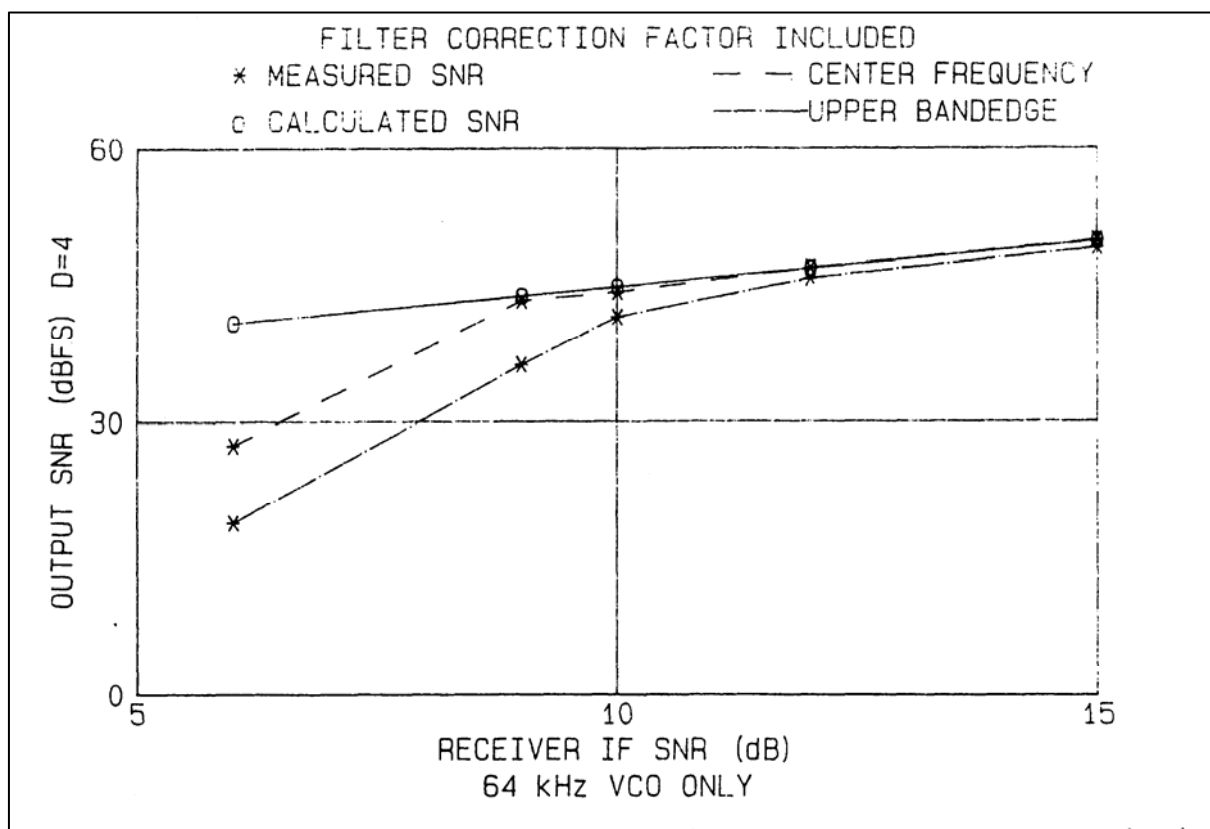

Figure 2-144. Measured and calculated SNRs with correction factors ($D = 4$).

2.8.3 Transmitter Deviation. An FM/FM system should be designed so that the subcarrier discriminator bandpass SNRs are greater than the receiver IF SNR. If this is not the case, the subcarrier discriminator will reach FM threshold before the receiver demodulator. The discriminator output noise will then be much worse than predicted by the equations in this report at a 12 dB IF SNR. A good rule of thumb is always to have either of the following relationships:

$$\frac{(\Delta f_i)^2 B_{IF}}{2 f_i^2 B_i} > 2$$

or

$$\Delta f_i > 2 f_i (B_i / B_{IF})^{1/2}$$

The peak deviation of a 5.4 kHz PBW SCO, which will be received with a 500 kHz IF bandwidth, should be at least 0.435 kHz.

Another good rule of thumb is to have the rms deviation of each SCO be at least 10 percent of the total rms deviation. This minimizes the probability that system non-linearities will introduce enough spurious signals to significantly degrade data quality. For example, a PBW multiplex of 7.5 percent channels from 1.7 to 93 kHz with a theoretical 9 dB/octave taper would have 52 dB more amplitude in the 93 kHz SCO than the 1.7 kHz SCO. This would overstress the dynamic range of the telemetry transmit, receive, and record system. Increasing the rms deviation of the lowest 8 channels to 10 percent of the original total rms deviation would increase the total rms deviation by less than 4 percent.

The first estimate transmitter deviation can be calculated if the required minimum data quality is known for each channel. Assume that the telemetry analysts would like to have the peak-to-peak noise (± 2 sigma) because of the telemetry RF link at a 12 dB IF SNR be no greater than 2 percent of the channel band edge-to-band edge voltage.

This is achieved when the rms value of the noise is less than 0.5 percent of full scale (SNR = 46 dBFS). Using this value in the corrected SNR equation (filter correction factor (Γ) = 6 dB) results in

$$\text{SNR} = 10 \log \left\{ \frac{6(\Delta f_i)^2 (\Delta f_{si})^2 B_{IF}}{(f_i)^2 (f_c)^3} \right\} + \text{SNR}_{IF} - \Gamma \quad (2-26)$$

$$46 = 10 \log \left\{ \frac{6(\Delta f_i)^2 (\Delta f_{si})^2 B_{IF}}{(f_i)^2 (f_c)^3} \right\} + 12 - 6$$

$$\Delta f_i = \frac{40.8 f_i (f_c)^{3/2}}{\Delta f_{si} (B_{IF})^{1/2}} \quad (2-27)$$

Further assume that we need a PBW multiplex of 7.5 percent channels with center frequencies from 1.7 to 93 kHz, deviation ratios of 5, and a 500 kHz receiver IF bandwidth. The peak deviation of the 93 kHz SCO should be

$$\Delta f_{93} = \frac{40.8 (93) (1.395)^{3/2}}{6.975 (500)^{1/2}} \text{ kHz peak}$$

$$\Delta f_{93} = 40.1 \text{ kHz peak or } 28.3 \text{ kHz rms.}$$

The rms deviation of the total signal will be approximately 1.3 times the rms deviation of the highest frequency subcarrier or 36.8 kHz. Another reasonable rule-of-thumb is that the rms deviation should be approximately one-sixth of the receiver IF bandwidth. This means the total rms deviation for a 500 kHz IF bandwidth should be approximately 83 kHz. If we double the values calculated using the equation we would get a total rms deviation of approximately 75 kHz. This means that each of the lower frequency SCOs should have an rms deviation of approximately 7.5 kHz or a peak deviation of 10.6 kHz. This is approximately one-eighth of the deviation of the 93 kHz channel (now 80.2 kHz peak). Since the deviation of fixed percentage PBW SCOs changes by a factor of 8 when the center frequency changes by 4, we only have to calculate the deviations for the channels with center frequencies above 23 kHz. Our equation is now

$$\Delta f_i = \frac{2(40.8)(f_i)(f_c)^{3/2}}{\Delta f_{si}(B_{IF})^{1/2}}$$

$$\Delta f_{70} = \frac{2(40.8)(70)(1.05)^{3/2}}{5.25(500)^{1/2}}$$

$$\Delta f_{70} = 52.4 \text{ kHz peak.}$$

Similarly, we get

$$\Delta f_{52.5} = 34 \text{ kHz peak}$$

$$\Delta f_{40} = 22.6 \text{ kHz peak}$$

$$\Delta f_{30} = 14.7 \text{ kHz peak}$$

$$\Delta f_{22} = 10.6 \text{ kHz peak}$$

$$\Delta f_{14.5} = 10.6 \text{ kHz peak}$$

•

•

•

$$\Delta f_{1.7} = 10.6 \text{ kHz peak.}$$

The overall rms transmitter deviation is approximately 77.3 kHz. An FM/FM system is designed which will provide data quality that exceeds the requirements by a minimum of 6 dB. However, no error is assumed because of tape recorder effects such as tape speed or flutter.

Now assume that we need to add a 165 kHz ± 15 percent SCO to the multiplex to transmit a 40 kilobit per second (kb/s) signal for a special test. We need to guarantee that the subcarrier discriminator will reach FM threshold later than the receiver demodulator will. Therefore, the minimum peak deviation is

$$\begin{aligned}\Delta f_{165} &= 2 (165) \{(165)(.3)/500\}^{1/2} \\ \Delta f_{165} &= 104 \text{ kHz peak or } 73.4 \text{ kHz rms.}\end{aligned}$$

If we now reduce the peak deviation of the other SCOs to the minimum values calculated earlier (with a minimum of 12 kHz peak), we get deviations of

$$\begin{aligned}\Delta f_{165} &= 104 \text{ kHz peak} \\ \Delta f_{93} &= 40.2 \text{ kHz peak} \\ \Delta f_{70} &= 26.2 \text{ kHz peak} \\ \Delta f_{52.5} &= 17 \text{ kHz peak} \\ \Delta f_{40} &= 12 \text{ kHz peak} \\ \Delta f_{30} &= 12 \text{ kHz peak} \\ &\bullet \\ &\bullet \\ &\bullet \\ \Delta f_{1.7} &= 12 \text{ kHz peak.}\end{aligned}$$

This gives a total rms deviation of 86.6 kHz.

This is slightly more than one-sixth of the receiver IF bandwidth. This is tolerable because most of the signal energy is in the 165 kHz SCO. The maximum desirable peak deviation, if only one SCO is present, is approximately 0.4 times the receiver IF bandwidth. The maximum desirable SCO frequency is also approximately 0.4 times the receiver IF bandwidth.

2.8.4 Receiver IF Bandwidth. The "best" receiver IF bandwidth is a function of the maximum SCO frequency, the transmitter deviation, and the link analysis.

- a. The main disadvantages of a wide receiver IF bandwidth are:
 - 1) FM threshold is reached sooner.
 - 2) If the signal is being predetection recorded, the tape speed may have to be increased because the predetection carrier frequency should be at least one-half of the IF bandwidth.
- b. The main disadvantages of a narrow IF bandwidth are:
 - 1) The receiver RF tuning becomes very critical.
 - 2) The video output distortion increases.
 - 3) The receiver may reach FM threshold sooner at the maximum deviation excursions.

c. Some general rules-of-thumb for receiver IF bandwidth are:

- 1) The IF bandwidth should be at least 2.5 times the highest SCO frequency.
- 2) The IF bandwidth should be at least 6 times the transmitter rms deviation.
- 3) The IF bandwidth should be narrow enough so that the probability of being above FM threshold is sufficiently high.

The discriminator output SNR is independent of the IF bandwidth when the signal is above FM threshold (no noise pops) and the distortion is much smaller than the video noise. Receiver IF bandwidths are usually only available in discrete steps with a step size between 50 and 100 percent. It is usually desirable to choose the narrowest IF bandwidth that meets c1 and c2 above.

2.8.5 Effect of Adjacent Channel or Co-channel Interference on FM/FM Discriminator Output.

This section will describe a method that can be used to calculate the amplitude at the discriminator output because of an interfering sine wave whose amplitude is less than the desired signal. Assume that the discriminator input can be described by

$$A \sin (2\pi f_1 t) + B \sin (2\pi f_2 t + \phi),$$

where

$A \sin (2\pi f_1 t)$ is the desired signal.

The frequency of the spurious signal at the discriminator output will be $|f_1 - f_2|$. The amplitude at the discriminator output will be

$$\frac{B K_d |f_1 - f_2| G_{IF}(f_2) G_{LPF}(|f_1 - f_2|)}{A G_{IF}(f_1)}$$

where

K_d = Discriminator gain constant (V/Hz)

$G_{IF}(f)$ = Discriminator bandpass filter voltage gain at frequency f

$G_{LPF}(f)$ = Discriminator output lowpass filter voltage gain at frequency f

As an example, calculate the interference between two adjacent CBW "A" channels when the lower channel is at UBE and the higher channel is at LBE. Assume a 48 kHz discriminator with input signals at 50 and 54 kHz. The frequency of the interfering signal will therefore be 4 kHz. The measured values of gain and voltage were:

$$B/A = 0.984$$

$$K_d = 2.5 \text{ V/kHz}$$

$$G_{IF}(54) = 0.160$$

$$G_{IF}(50) = 0.816$$

$$G_{LPF}(4) = 0.186$$

Therefore, the calculated output amplitude at 4 kHz is

$$\text{Amplitude} = 0.984 (2.5) (4) (0.16) (0.186) / \{2 (0.816)\}$$

$$\text{Amplitude} = 0.254 \text{ V rms.}$$

The measured amplitude at a frequency of 4 kHz was 0.249 V rms. These values agree very well.

As a second example let us assume we have a 48 kHz desired signal with an interfering signal at 48.4 kHz whose amplitude is one-tenth of the desired signal. The frequency of the spurious component will be 400 Hz ($|48 - 48.4|$ kHz). The calculated amplitude is

$$0.1(2.5)(0.4)(1.0)(0.993)/\{2 (0.999)\} = 0.0703 \text{ V rms.}$$

The measured amplitude under these conditions at 400 Hz was 0.0694 V rms.

If either the desired or the undesired signal is modulated, the instantaneous spurious output can be calculated as shown above using the instantaneous amplitude and frequency of both signals. This method also works when there is more than one undesired signal. The measurements were made using a pulse averaging discriminator. Other types of discriminators may have a loop filter gain that must also be included.

2.8.6 Record Level for Tape Recorder. Figure [2-145](#) and Figure [2-146](#) show the effects of recording a non-preemphasized CBW multiplex at normal record level (0 dBN) and at one-half of normal record level (-6 dBN). Normal record level is the rms input voltage of a sine wave at one-tenth upper band edge that produces 1 percent third harmonic distortion. Figure 2-145 shows that the distortion terms are only 30 dB below the signals with a 0 dBN input. Figure 2-146 shows that the largest distortion terms are approximately 38 dB below the signals with a -6 dBN input. The noise is smaller than the distortion in both cases. Therefore, the best record level for an FM/FM multiplex will frequently be less than 0 dBN.

2.8.7 Effect of Tape Recorder Flutter and Speed Error on FM/FM Data Quality. The FM/FM data accuracy is directly related to the difference in instantaneous tape speed at the time of recording and at the time of playback. The error can also be increased by any tape speed errors during tape copying (dubbing). Typical specifications for laboratory recorders give absolute tape speed accuracy of ± 0.1 percent in tachometer mode and ± 0.01 percent in tape servo mode. The typical flutter in tachometer mode at 30 ips is 0.2 percent peak-to-peak (2 sigma value) or 0.05 percent rms. Recorders in severe environments can have errors of ten times these values. If we reproduce data from a tape copy and make worst case assumptions (laboratory recorder), we can have a tape speed error of 0.4 percent (all operations in tachometer mode) and a flutter error of 0.1 percent rms. The effect that this will have on data quality varies with the percentage deviation of the subcarrier channel. The smallest percentage deviation channel is the 176A channel, which has a specified maximum peak-to-peak deviation of 4 kHz, which is 2.27 percent of the center frequency. A speed error of 0.4 percent translates to an error of 17.6 percent of full scale. An rms flutter value of 0.1 percent translates to rms noise of 4.4 percent of

full scale. The narrowest PBW channels have maximum deviation limits of ± 7.5 percent. This translates to a speed error of 1.3 percent of full scale and a flutter error of 0.33 percent of full scale. These errors can be greatly reduced by the use of a properly damped tape playback servo system, tape speed compensation, and/or digital time base correction.

2.8.8 Preemphasis. Preemphasis is the process of increasing the amplitude (deviation) of the higher frequency and wider bandwidth SCOs to keep the SNRs at the discriminator bandpass outputs nearly the same for all channels with the same data quality requirements. The SNR (voltage ratio) at the output of the bandpass filter is directly proportional to the SCO peak deviation, and inversely proportional to the SCO center frequency and the square root of the discriminator bandpass bandwidth. Therefore, the SCO peak deviation should be proportional to the product of the SCO center frequency and the square root of the discriminator bandpass bandwidth. The equation for calculating SCO peak deviation provides the proper preemphasis for each SCO. Figure [2-147](#) through Figure [2-151](#) show typical baseband spectra for CBW and PBW multiplexes with and without preemphasis. Figure [2-150](#) illustrates the problem of using a straight 9 dB/octave preemphasis for a PBW multiplex. The low frequency signals disappear. Figure [2-151](#) shows the same signal with a minimum rms deviation of 10 percent of the total rms deviation.

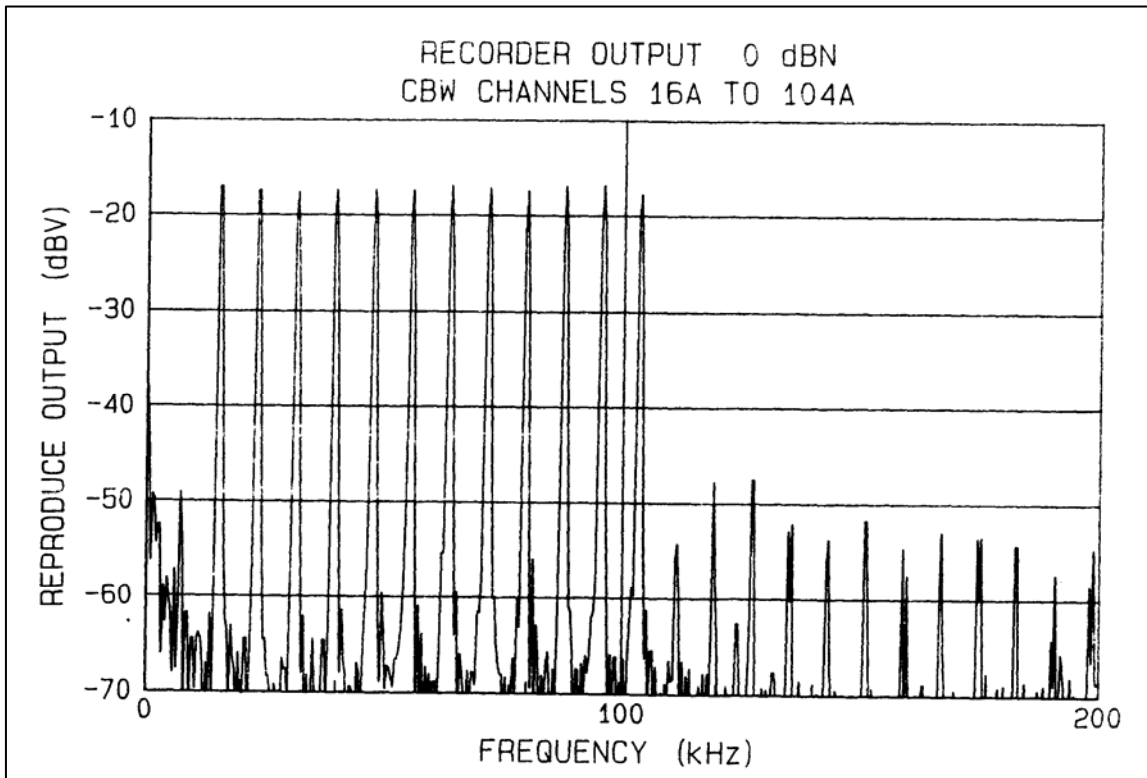

Figure 2-145. Tape recorder output with normal record level CBW input.

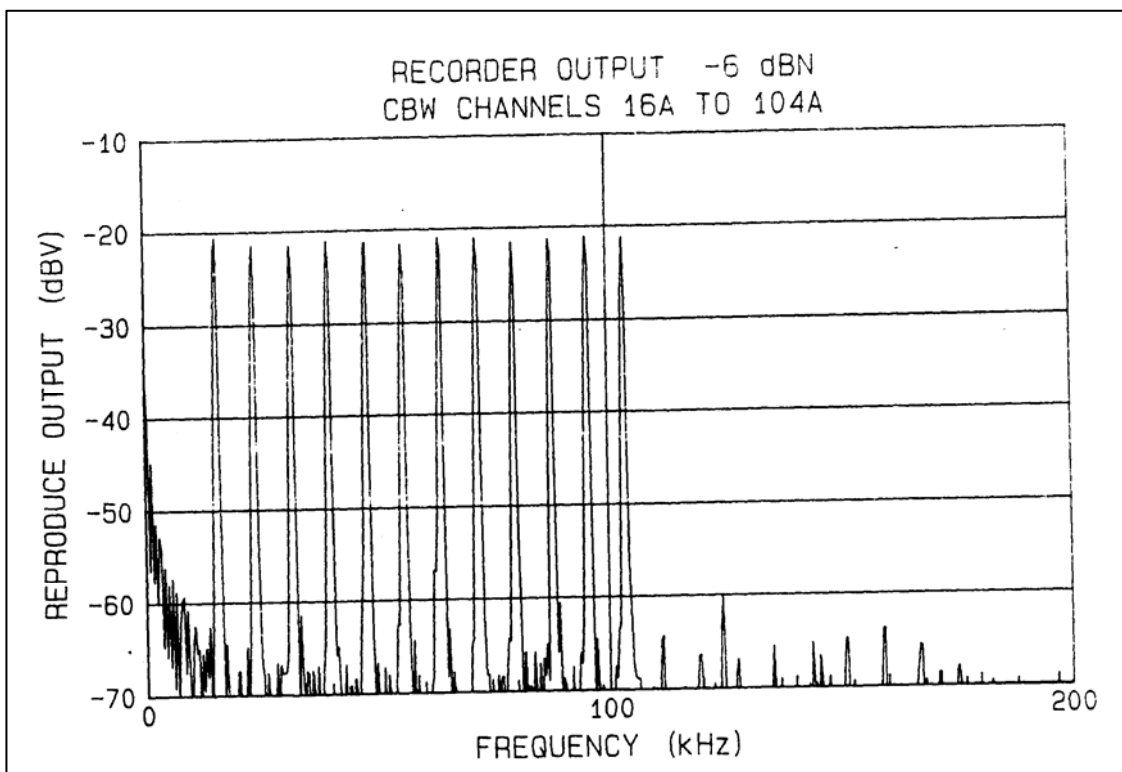

Figure 2-146. Tape recorder output with (normal record level) /2 CBW input.

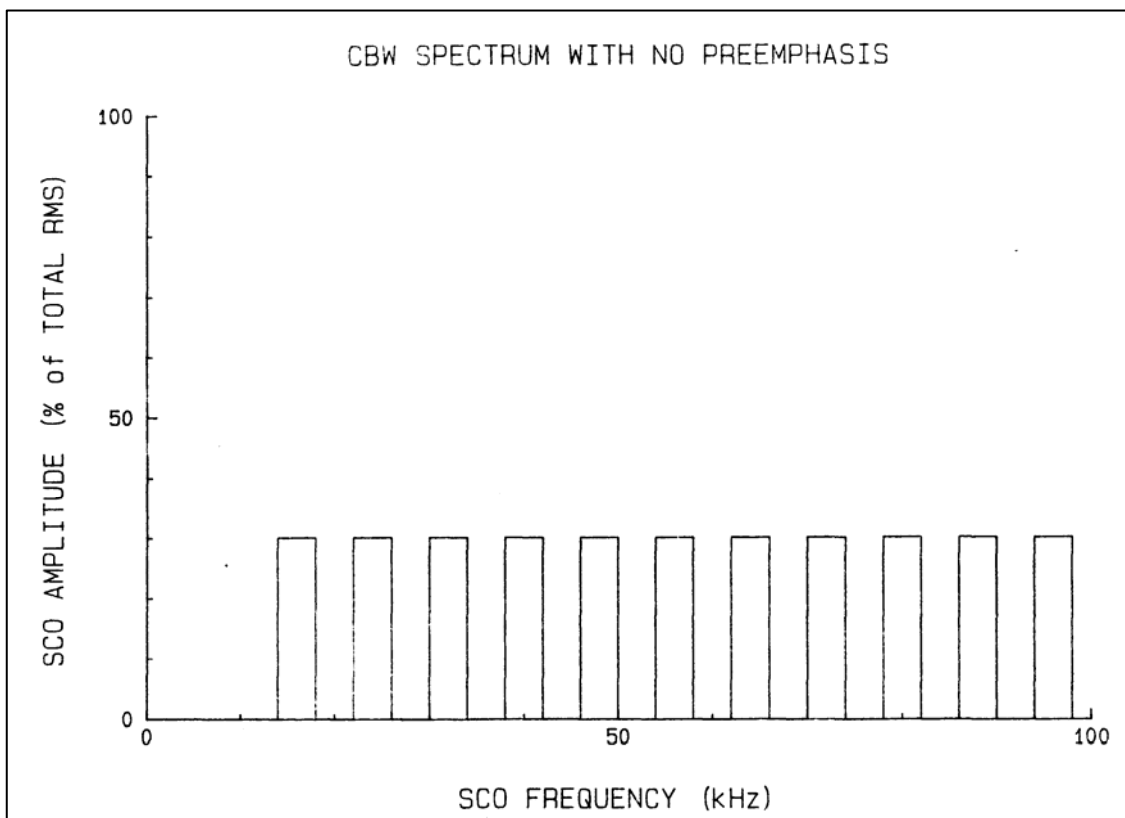

Figure 2-147. CBW spectrum with no preemphasis.

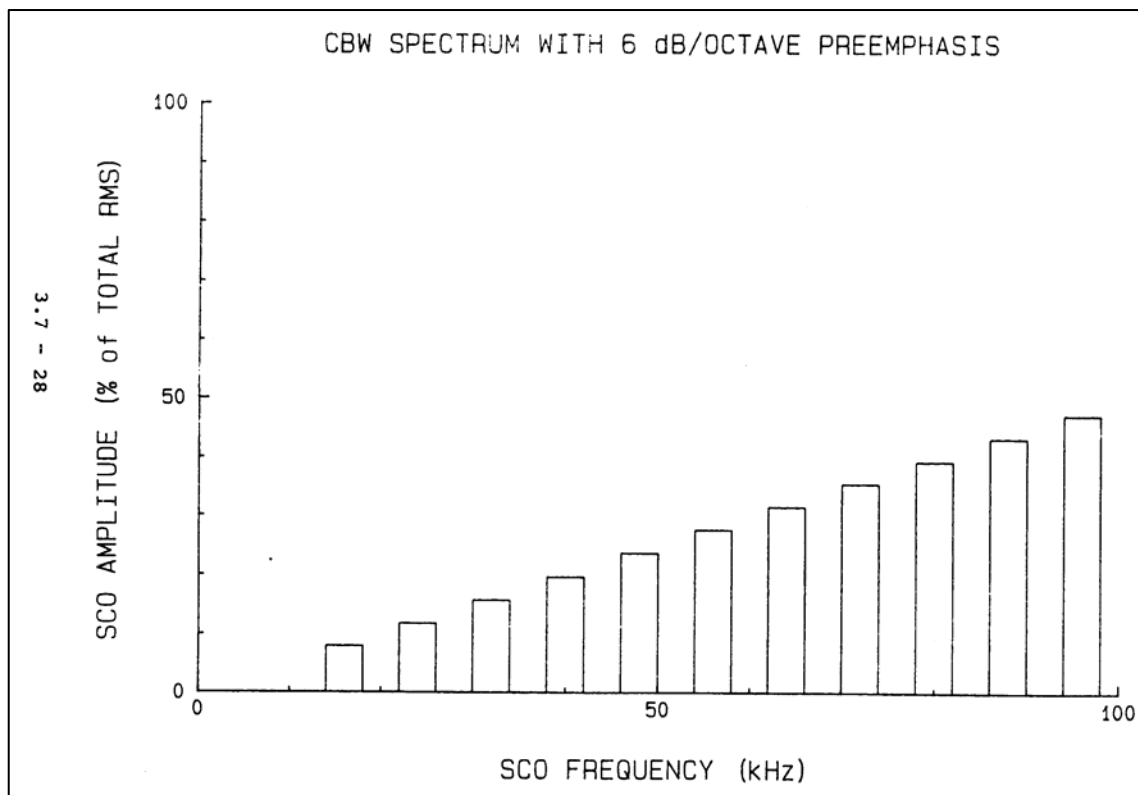

Figure 2-148. CBW spectrum with 6 dB/octave preemphasis.

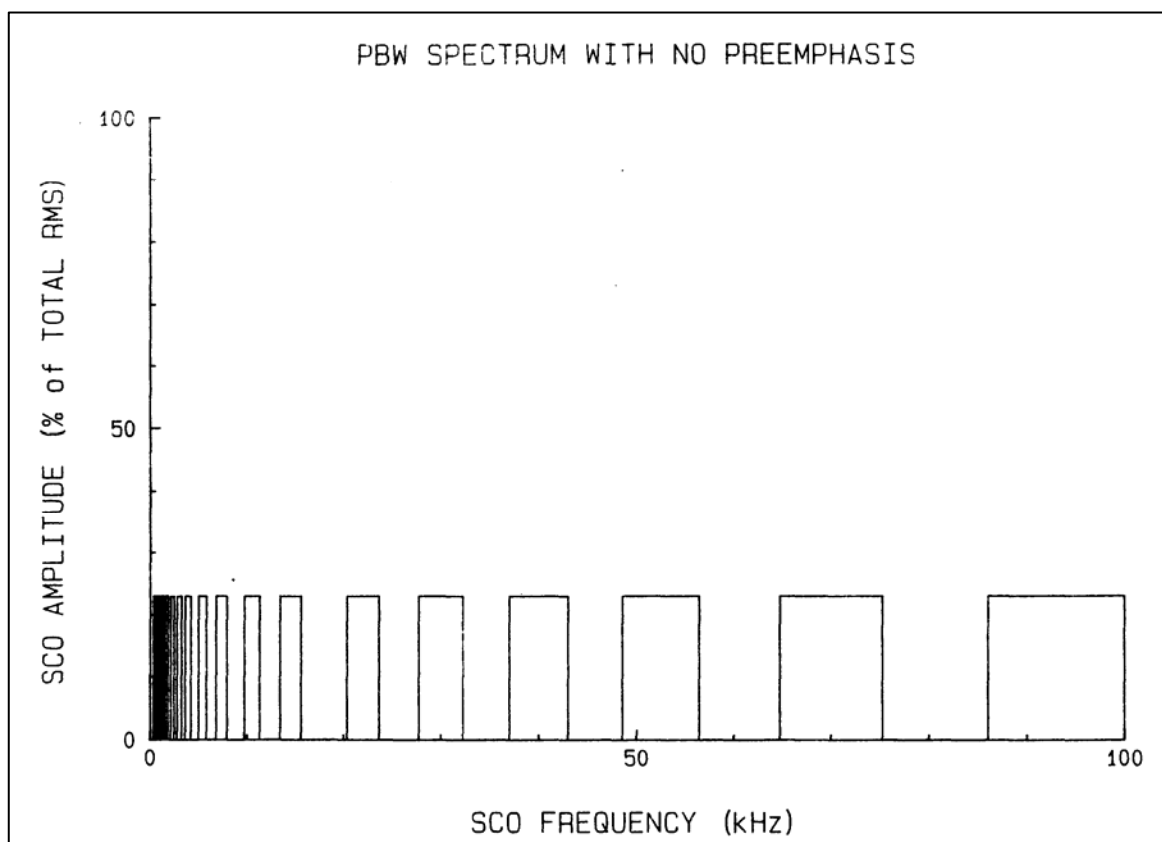

Figure 2-149. PBW spectrum with no preemphasis.

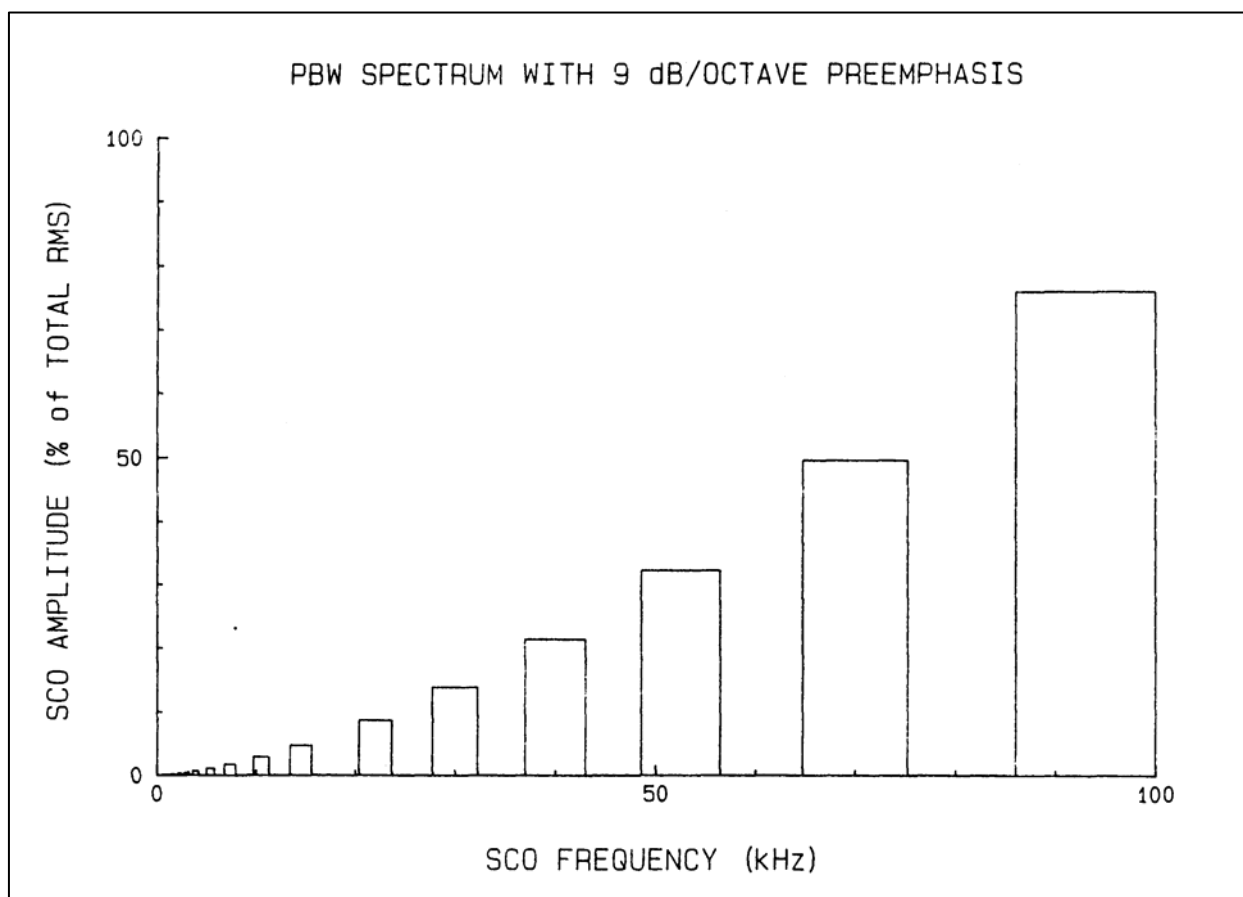

Figure 2-150. PBW spectrum with 9 dB/octave preemphasis.

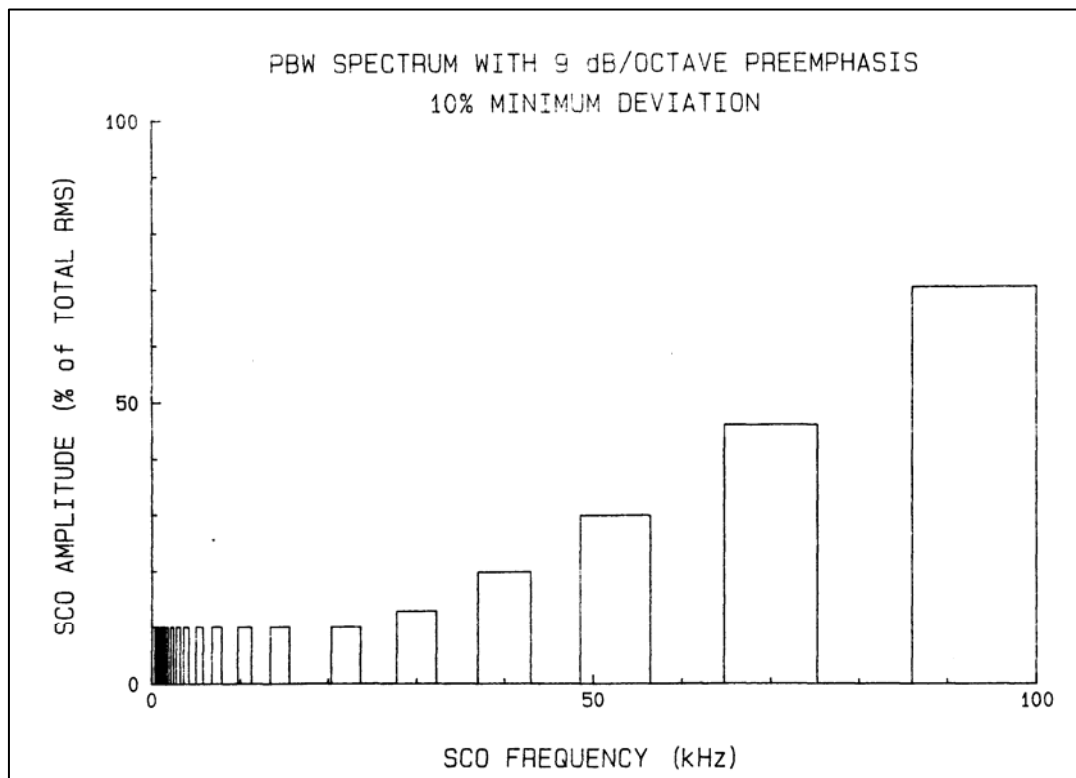

Figure 2-151. PBW spectrum with 9 dB/octave preemphasis and 10 percent minimum amplitude.

2.8.9 **FM Spectrum With Single Sine Wave Modulation.** We can represent a sine wave carrier that is frequency modulated by a single sine wave by the following (See Reference [2gg](#)):

$$f(t) = \cos(\omega_c t + \beta \sin \omega_m t) \quad (2-28)$$

$$f(t) = \cos(\omega_c t) \cos(\beta \sin \omega_m t) - \sin(\omega_c t) \sin(\beta \sin \omega_m t)$$

$$f(t) = J_0(\beta) \cos(\omega_c t) - J_1(\beta) [\cos(\omega_c - \omega_m)t - \cos(\omega_c + \omega_m)t] \\ + J_2(\beta) [\cos(\omega_c - 2\omega_m)t + \cos(\omega_c + 2\omega_m)t] \\ - J_3(\beta) [\cos(\omega_c - 3\omega_m)t - \cos(\omega_c + 3\omega_m)t] \\ + \dots,$$

where

$$\begin{aligned} \omega_c &= \text{Frequency of carrier in radians/sec.} \\ \omega_m &= \text{Frequency of modulating signal in radians/sec.} \\ \beta &= \text{Peak deviation/frequency of modulating signal.} \\ J_I(\beta) &= i^{\text{th}} \text{ order Bessel function of the first kind.} \end{aligned}$$

The amplitude of the remnant carrier is $J_0(\beta)$, the amplitudes of the sideband pairs spaced $\pm\omega_m$ away from the carrier are $J_1(\beta)$, etc. The unmodulated carrier amplitude is assumed to be 1. Table [2-10](#) lists the amplitude (in dBc) of $J_1(x)$ for $I = 0, 1, 2, 3, 4, 5$, and 6 and for $x = 0.1$ to 5.0 in steps of 0.1. The value of -18.79 dBc for $J_2(1.0)$ means that the theoretical amplitude of the components at $\omega_c \pm 2\omega_m$ will be 0.1149 times the unmodulated carrier amplitude for $\beta = MI = 1.0$. This is illustrated in Figure [2-152](#).

If a carrier is modulated with a single sine wave, the relative amplitudes of the carrier components can be used to determine the peak deviation. This is commonly done using either the first null of the carrier or the first null of the first sideband. In Table [2-10](#), J_0 has a minimum at approximately 2.4 and J_1 , has a minimum at approximately 3.8. The actual values of MI for the first two carrier nulls are approximately 2.40482 and 5.52008 while the first null of J_1 occurs at approximately 3.83171. If the modulation amplitude is set to a very low value and the amplitude is increased slowly until the first carrier null occurs (monitor modulated carrier on spectrum analyzer), the amplitude that produces a peak deviation of approximately 2.405 times the modulating frequency is found. At this MI, the amplitude of the second sideband should be at least 1 dB lower than the amplitude of the first sideband, and the amplitudes of the higher order sidebands should decrease rapidly. This is illustrated in Figure [2-153](#). The relative amplitudes of the sidebands can also be used to calculate the effective peak deviation in situations where it is not possible to vary parameters to achieve a null. The equations in Table [2-11](#) can be used to calculate the approximate modulation index for $0.1 < MI < 1.6$ from the difference in amplitude between J_0 and J_1 .

| |
|--|
| TABLE 2-10. FM SIDEBAND POWER VERSUS MI |
|--|

| FM SIDEBAND POWER (dBc) | | | | | | | |
|-------------------------|--------|--------|--------|--------|---------|---------|---------|
| MI | J0 | J1 | J2 | J3 | J4 | J5 | J6 |
| .10 | -.02 | -26.03 | -58.07 | -93.63 | -131.69 | -171.69 | -213.27 |
| .20 | -.09 | -20.04 | -46.05 | -75.58 | -107.62 | -141.60 | -177.16 |
| .30 | -.20 | -16.58 | -39.04 | -65.05 | -93.56 | -124.01 | -156.04 |
| .40 | -.35 | -14.15 | -34.10 | -57.59 | -83.59 | -111.54 | -141.07 |
| .50 | -.55 | -12.31 | -30.28 | -51.82 | -75.88 | -101.88 | -129.47 |
| .60 | -.80 | -10.85 | -27.20 | -47.13 | -69.59 | -94.00 | -120.00 |
| .70 | -1.10 | -9.66 | -24.61 | -43.19 | -64.29 | -87.35 | -112.01 |
| .80 | -1.45 | -8.66 | -22.40 | -39.79 | -59.72 | -81.61 | -105.10 |
| .90 | -1.86 | -7.83 | -20.48 | -36.81 | -55.70 | -76.56 | -99.01 |
| 1.00 | -2.32 | -7.13 | -18.79 | -34.17 | -52.12 | -72.05 | -93.58 |
| 1.10 | -2.86 | -6.54 | -17.29 | -31.80 | -48.90 | -67.99 | -88.68 |
| 1.20 | -3.46 | -6.05 | -15.95 | -29.66 | -45.98 | -64.29 | -84.22 |
| 1.30 | -4.15 | -5.65 | -14.75 | -27.72 | -43.31 | -60.91 | -80.12 |
| 1.40 | -4.93 | -5.32 | -13.67 | -25.93 | -40.85 | -57.79 | -76.35 |
| 1.50 | -5.82 | -5.07 | -12.69 | -24.30 | -38.59 | -54.90 | -72.84 |
| 1.60 | -6.83 | -4.88 | -11.80 | -22.79 | -36.48 | -52.21 | -69.57 |
| 1.70 | -8.00 | -4.76 | -11.00 | -21.40 | -34.52 | -49.70 | -66.52 |
| 1.80 | -9.37 | -4.71 | -10.28 | -20.10 | -32.69 | -47.34 | -63.65 |
| 1.90 | -11.00 | -4.71 | -9.63 | -18.91 | -30.98 | -45.13 | -60.95 |
| 2.00 | -13.00 | -4.78 | -9.05 | -17.79 | -29.37 | -43.05 | -58.40 |
| 2.10 | -15.57 | -4.91 | -8.53 | -16.76 | -27.86 | -41.08 | -55.99 |
| 2.20 | -19.14 | -5.10 | -8.07 | -15.79 | -26.44 | -39.22 | -53.70 |
| 2.30 | -25.11 | -5.35 | -7.66 | -14.90 | -25.10 | -37.46 | -51.52 |
| 2.40 | -52.01 | -5.68 | -7.31 | -14.06 | -23.83 | -35.79 | -49.46 |
| 2.50 | -26.31 | -6.07 | -7.01 | -13.29 | -22.64 | -34.20 | -47.48 |
| 2.60 | -20.28 | -6.54 | -6.76 | -12.57 | -21.51 | -32.69 | -45.60 |
| 2.70 | -16.93 | -7.10 | -6.57 | -11.90 | -20.45 | -31.25 | -43.81 |
| 2.80 | -14.65 | -7.75 | -6.42 | -11.29 | -19.44 | -29.88 | -42.09 |
| 2.90 | -12.98 | -8.51 | -6.32 | -10.72 | -18.49 | -28.57 | -40.44 |
| 3.00 | -11.70 | -9.39 | -6.27 | -10.20 | -17.59 | -27.32 | -38.87 |
| 3.10 | -10.69 | -10.43 | -6.26 | -9.72 | -16.74 | -26.14 | -37.36 |
| 3.20 | -9.89 | -11.66 | -6.31 | -9.29 | -15.93 | -25.00 | -35.91 |
| 3.30 | -9.26 | -13.13 | -6.41 | -8.90 | -15.18 | -23.91 | -34.51 |
| 3.40 | -8.77 | -14.93 | -6.56 | -8.56 | -14.46 | -22.88 | -33.18 |
| 3.50 | -8.40 | -17.24 | -6.77 | -8.25 | -13.79 | -21.89 | -31.89 |
| 3.60 | -8.14 | -20.40 | -7.04 | -7.99 | -13.16 | -20.95 | -30.66 |
| 3.70 | -7.98 | -25.38 | -7.36 | -7.76 | -12.57 | -20.04 | -29.47 |
| 3.80 | -7.90 | -37.84 | -7.76 | -7.58 | -12.02 | -19.18 | -28.33 |
| 3.90 | -7.92 | -31.29 | -8.23 | -7.43 | -11.50 | -18.36 | -27.24 |
| 4.00 | -8.02 | -23.60 | -8.77 | -7.33 | -11.02 | -17.58 | -26.18 |
| 4.10 | -8.21 | -19.72 | -9.41 | -7.26 | -10.58 | -16.84 | -25.17 |
| 4.20 | -8.48 | -17.16 | -10.16 | -7.24 | -10.17 | -16.13 | -24.19 |
| 4.30 | -8.85 | -15.29 | -11.02 | -7.26 | -9.80 | -15.46 | -23.25 |
| 4.40 | -9.31 | -13.86 | -12.04 | -7.33 | -9.46 | -14.82 | -22.35 |
| 4.50 | -9.88 | -12.73 | -13.24 | -7.44 | -9.16 | -14.21 | -21.49 |
| 4.60 | -10.57 | -11.82 | -14.68 | -7.60 | -8.89 | -13.64 | -20.65 |
| 4.70 | -11.39 | -11.09 | -16.45 | -7.80 | -8.65 | -13.10 | -19.86 |
| 4.80 | -12.38 | -10.50 | -18.71 | -8.06 | -8.45 | -12.59 | -19.09 |
| 4.90 | -13.57 | -10.04 | -21.80 | -8.38 | -8.28 | -12.11 | -18.36 |
| 5.00 | -15.01 | -9.69 | -26.64 | -8.76 | -8.15 | -11.66 | -17.65 |

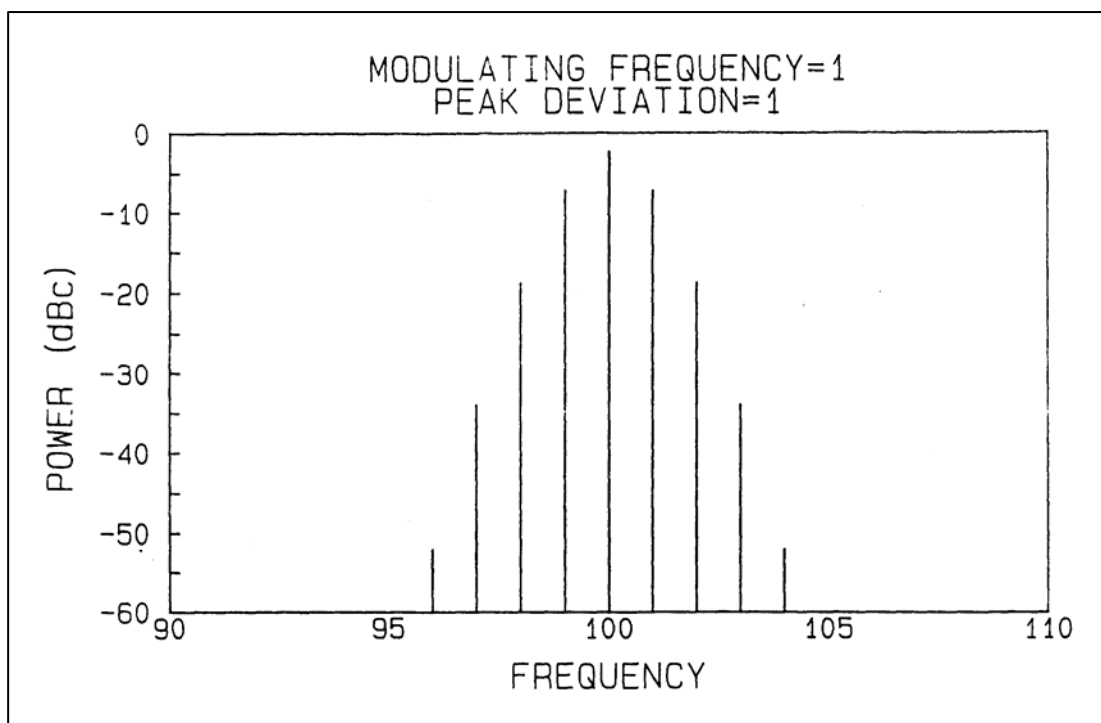

Figure 2-152. FM spectrum with single sine wave modulation and $MI = 1$.

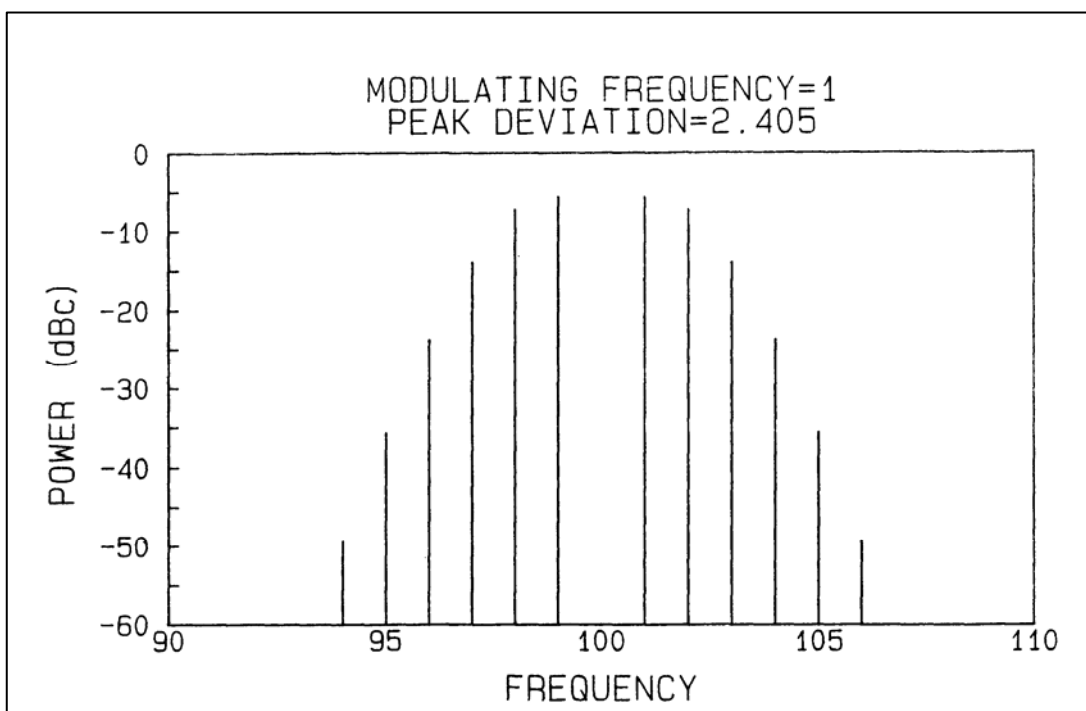

Figure 2-153. FM spectrum with single sine wave modulation and MI = 2.405.

| TABLE 2-11. COEFFICIENTS OF EQUATION FOR USING J_0/J_1 (DB) TO CALCULATE MI FOR $MI < 1.6$ | | | | | |
|--|---------------|--------|----------|-----------|-----------|
| MIN J_0/J_1 | MAX J_0/J_1 | A_0 | A_L | A_2 | MAX ERROR |
| 16.5 | 26 | 1.1237 | -0.06922 | 0.001150 | 0.0017 |
| 10 | 16.5 | 1.4582 | -0.10886 | 0.002332 | 0.0007 |
| 6 | 12.7 | 1.4962 | -0.11530 | 0.002601 | 0.0004 |
| 2.5 | 7 | 1.4540 | -0.10191 | 0.001545 | 0.0009 |
| 3.5 | 6 | 1.4560 | -0.10233 | 0.001546 | 0.0002 |
| -2 | 2.5 | 1.4345 | -0.08780 | -0.001232 | 0.0010 |

$$MI = a_0 + a_1x + a_2x^2 \quad (2-29)$$

where

$x = J_0/J_1$ (dB) or J_0 (dB) - J_1 (dB)

MI = peak deviation/modulating frequency

Many modern spectrum analyzers allow the measurement of the difference in amplitude between two components simply and accurately. The equations in Table 2-11 are useful when the higher order components (J_2, J_3 , etc.) are at least 5 dB lower in amplitude than the smaller of J_0 and J_1 . This occurs when the modulation index is less than approximately 1.6. The equations were developed by fitting a least squares curve of the form $MI = a_0 + a_1x + a_2x^2$ to the ideal values for MI, $J_0(MI)$, and $J_1(MI)$. The accuracy of these equations is better than 0.5 percent for $J_0/J_1 < 20$ dB. As an example, assume that J_0 is 6 dB larger than J_1 , and all other components are at least 10 dB lower than J_1 . The fifth set of coefficients has the lowest maximum error of the sets that include 6 dB for J_0/J_1 . Using this equation, we get

$$MI = 1.456 + (-0.10233)(6) + .001546 (6)^2$$

$$MI = 0.8977.$$

If the sine wave modulation frequency is 100 kHz, then the peak deviation is 89.77 kHz. The modulation frequency is the difference in frequency between any two adjacent spectral components. If we look up 0.9 on the Bessel table in Table 2-10 we get $J_0 = -1.86$ dB and $J_1 = -7.83$ dB.

Reference 2gg also derives an equation for calculating the RF spectrum for square wave modulation. The magnitude of the n^{th} sideband is

$$\frac{2\beta \sin \left[\frac{(\beta - n)\pi}{2} \right]}{\pi (\beta^2 - n^2)}.$$

Therefore, the first carrier null for square wave modulation will occur at a modulation index (β) of 2 (because $\sin(\pi) = 0$).

2.8.10 RF Spectrum of an FM/FM Multiplex. An RF carrier that is frequency modulated by the sum of N sine waves can be represented by

$$f_c(t) = \cos [w_c t + \beta_1 \sin (w_1 t + \phi_1) + \beta_2 \sin (w_2 t + \phi_2) + \dots + \beta_n \sin (w_n t + \phi_n)] \quad (2-30)$$

It can be shown that the amplitude at frequency

$$w_c \pm a_1 w_1 \pm a_2 w_2 \pm \dots \pm a_n w_n$$

is equal to

$$J_{a_1}(\beta_1) J_{a_2}(\beta_2) \dots J_{a_n}(\beta_n)$$

or in dB

$$J_{a_1}(\beta_1) + J_{a_2}(\beta_2) + \dots + J_{a_n}(\beta_n).$$

The above will be illustrated with a few simple examples. First, assume a carrier frequency of 100 modulated by sine waves at frequencies of 1 and 1.4 both with a modulation index of 1. The power at the carrier frequency will be $J_0(1) + J_0(1)$ or $-2.32 + (-2.32) = -4.64$ dBc. The power at 99 and 101 will be $J_1(1) + J_0(1)$ or $-7.13 + (-2.32) = -9.45$ dBc. The power at 98.6 and 101.4 will be $J_0(1) + J_1(1)$ or $-2.32 + (-7.13) = -9.45$ dBc. The power at 96.6, 99.4, 100.6, and 103.4 will be $J_2(1) + J_1(1) = -18.79 + (-7.13) = -25.92$. This modulated signal spectrum is illustrated in Figure [2-154](#). The data in Figure 2-154 show that the 99 percent power bandwidth is 5.6 (4 times higher modulating frequency) and the -60 dBc bandwidth is 13.2 (8 times higher modulating frequency + 2 times lower modulating frequency). Figure [2-155](#) shows the effect of increasing the modulation index of the lower frequency to 2.4. The carrier amplitude has been decreased to $J_0(2.4) + J_1(1) = -52.01 + (-2.32) = -54.33$ dBc. If any of the individual modulation indices produces a carrier null, the carrier will be nulled independent of the other modulation indexes. This may be very difficult to detect with many modulating signals because some of the sum and difference combinations will produce components at frequencies very close to the carrier frequency. The -60 dBc bandwidth for this signal was 16.4 (8 times the lower frequency + 6 times the higher frequency). Figure [2-156](#) and Figure [2-157](#) illustrate the spectra of a carrier modulated by three sine waves. Figure 2-156 shows that most of the power is in the carrier component for three sine waves each with a modulation index of 0.6. The spectrum in Figure 2-157 is similar to Figure 2-155 but with many more spectral components. The -60 dBc bandwidth is 13.42 for Figure 2-156 and 18.42 for Figure 2-157. In general, with several SCOs the -60 dBc bandwidth will almost always be less than eight times the highest frequency SCO if the modulation indices are less than one and less than six times the rms deviation if the modulation indices are greater than one.

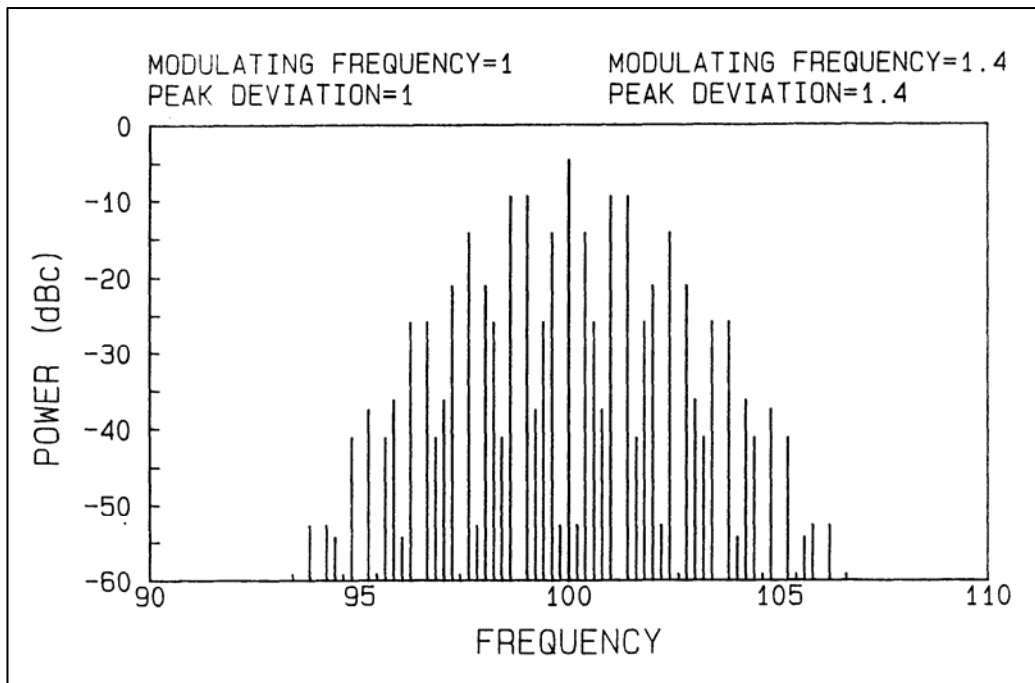

Figure 2-154. FM spectrum with two sine wave modulation and $MI = 1$.

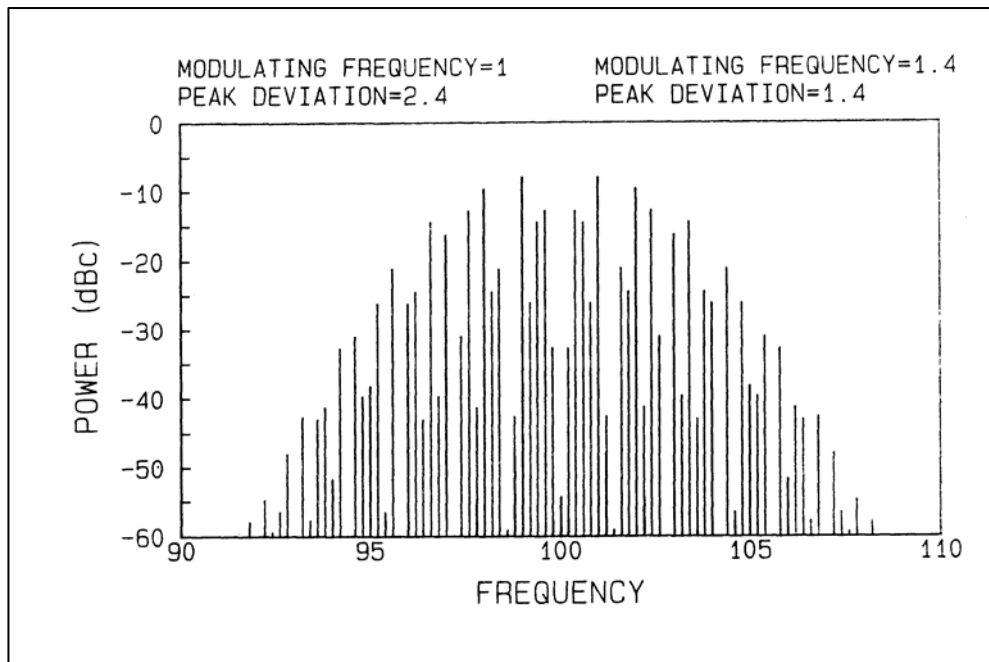

Figure 2-155. FM spectrum with two sine wave modulation and $MI = 1$ and $MI = 2.4$.

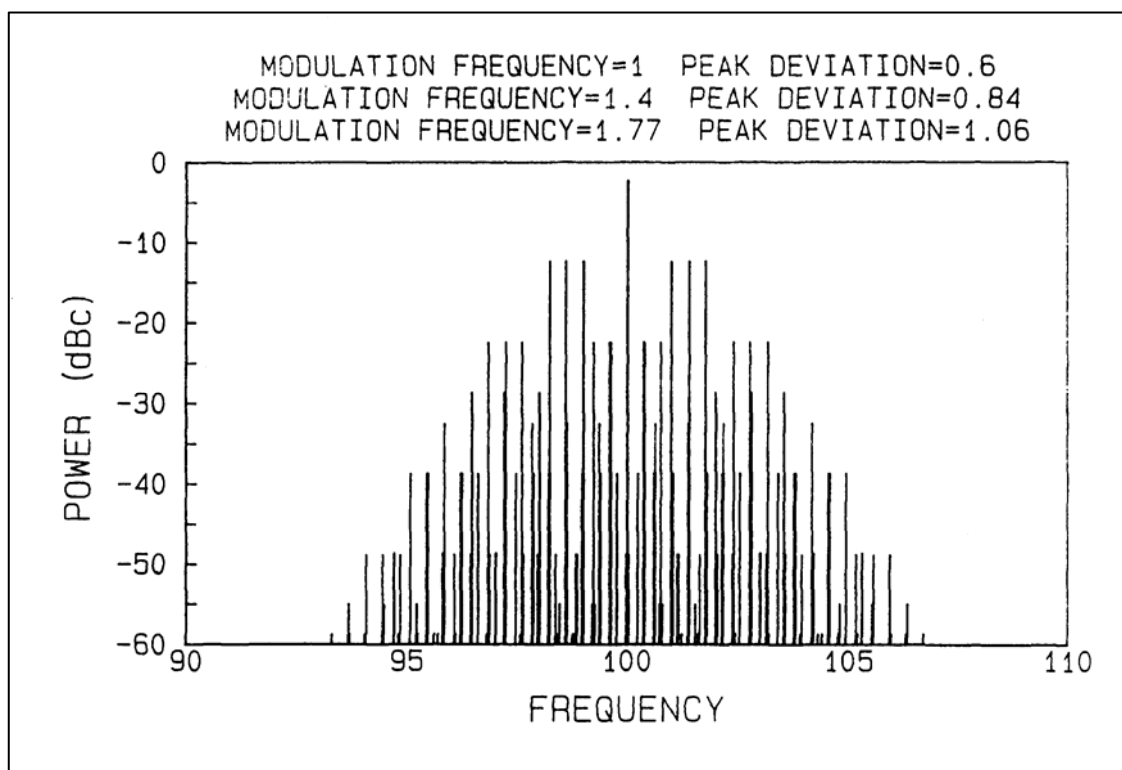

Figure 2-156. FM spectrum with three sine wave modulation and MI = 0.6.

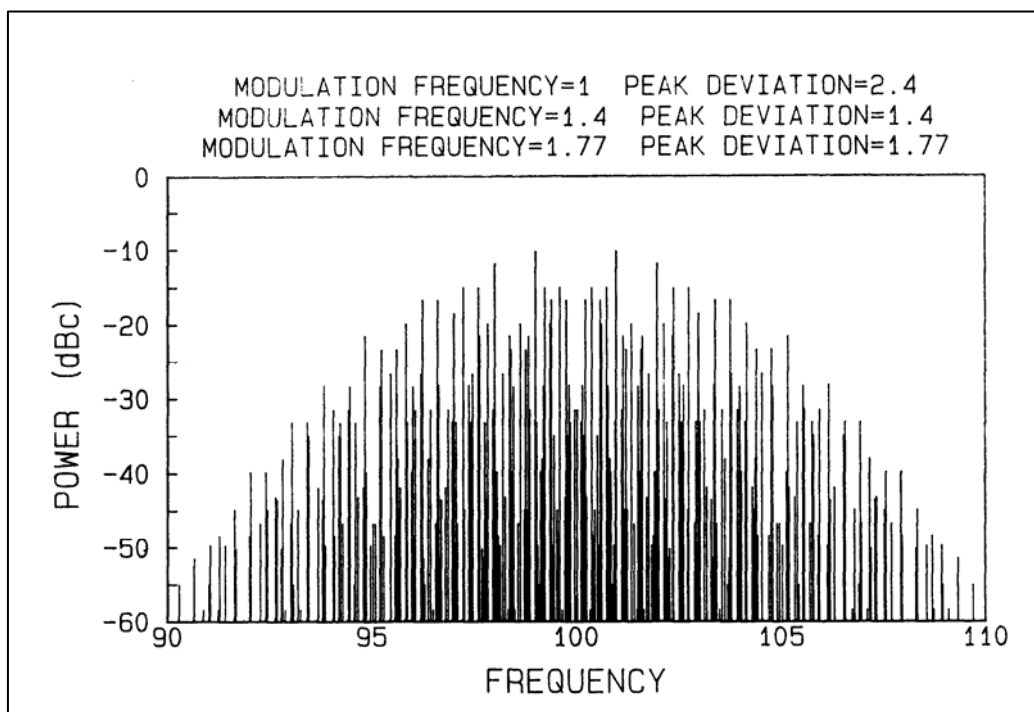

Figure 2-157. FM spectrum with three sine wave modulation and $MI = 1$ and $MI = 2.4$.

2.8.11 Noise Power Ratio. Noise loading tests have been used for many years to test various communications systems. This section will describe noise loading testing as related to an FM/FM telemetry link. One output of a noise loading test is the noise power ratio (NPR). The NPR is the decibel ratio of the noise level at the output of the system under test at the measurement frequency with the baseband fully loaded to the level with all of the baseband noise loaded except for a narrow band around the measurement frequency.

A noise power ratio test uses a noise signal to simulate an FM/FM multiplex. Either white noise (constant power spectral density) or spectrally shaped noise can be used. The noise power ratio is measured using the following steps:

- a. Measure the noise power in a narrow bandwidth (bandpass filter).
- b. Insert a notch filter in the noise source that is somewhat wider than the bandpass filter in procedure "a". Adjust the noise level to keep the source rms noise level constant. Measure the noise power at the output of the bandpass filter. The ratio of these two noise powers is the NPR.
- c. Decrease the source noise amplitude to zero. Measure the noise power at the output of the bandpass filter. The ratio of the noise measured in procedure "a" to the noise measured in "c" is called the noise power ratio floor NPRF or NPRO.

The use of NPR to predict FM/FM subcarrier SNR is described in Reference [2hh](#) and Reference [2ii](#)). These publications presented experimental NPR values and subcarrier discriminator SNRs and derived equations to predict the subcarrier discriminator output SNR from the NPR. The agreement between theory and experiment was quite good. The basic equation used to estimate discriminator output SNR (power ratio) from NPR (when $\text{NPR} = \text{NPRF}$) was

$$(\text{S/N})_{\text{LPF}} = \{48 \Gamma (\Delta f)^3 (\text{NPR} - 1)\} / (f_c)^3 \quad (2-31)$$

The expected noise power ratio because of FM demodulator noise (NPRF) can be calculated from the FM noise equations. Assume that a white noise modulation signal with a bandwidth B_n and rms deviation Δf_r is used. Therefore, the noise power in bandwidth b is $(\Delta f_r)^2 b/B_n$. Substituting this into the bandpass filter SNR equation, we get

$$\text{NPRF} = \frac{B_{\text{IF}} \text{SNR}_{\text{IF}} (\Delta f_r)^2 b / B_n}{f_0^2 b},$$

or

$$\text{NPRF} = \frac{B_{\text{IF}} \text{SNR}_{\text{IF}} (\Delta f_r)^2}{f_0^2 B_n},$$

where

SNR_{IF} = IF SNR (power ratio)

Δf_r = RF rms deviation because of noise source

f_0 = noise measurement frequency

$$\text{NPRF (dB)} = \text{SNR}_{\text{IF}} \text{ (dB)} + 10 \log \left(\frac{B_{\text{IF}} (\Delta f_r)^2}{B_n f_0^2} \right) \quad (2-32)$$

If noise with a 6 dB/octave taper with a 3 dB point of f_c is used, the noise spectrum is proportional to $1 + (f/f_c)^2$. The NPRF for this case can be shown to be

$$\text{NPRF} = (K \text{ SNR}_{\text{IF}} B_{\text{IF}}) / f_0^2$$

or

$$\text{NPRF (dB)} = \text{SNR}_{\text{IF}} \text{ (dB)} + 10 \log \{ (K B_{\text{IF}}) / f_0^2 \}$$

where

$$K = \frac{(\Delta f_r)^2 \left(1 + \frac{f_0^2}{f_c^2}\right)}{(f_{\text{max}} - f_{\text{min}}) + \frac{(f_{\text{max}})^3 - (f_{\text{min}})^3}{3 f_c^2}}$$

The measured noise power ratio also includes effects because of incidental FM and intermodulation distortion. However, at IF SNRs below 20 dB these effects are usually swamped out by the FM demodulator noise. This assumes that the receiver IF filter has nearly constant group delay over at least a bandwidth equal to 4 times the rms deviation.

Comparisons between measured NPRs and NPRs calculated using the equations presented in the first part of this subsection are shown in Figure 2-158 through Figure 2-163. White noise was used for the data in Figure 2-158 and Figure 2-159, while the noise was preemphasized at 6 dB/octave (23 kHz 3 dB point) for the data in Figure 2-160 through Figure 2-163. These figures show that the measured NPRs were almost always within 2 dB of the calculated values for IF SNRs above 10 dB. The exceptions were the NPRs at 14 kHz with a 500 kHz IF bandwidth (Figure 2-160) and with a 1500 kHz IF bandwidth, 10.2 dB IF SNR, and 200 kHz rms deviation (Figure 2-163). Therefore, the measured NPRs are in good agreement with the calculated NPRs when the rms deviation is less than approximately one-fifth of the IF bandwidth, and the IF SNR is greater than 10 dB and less than 20 dB. The calculated and measured values of NPR also agree well at higher IF SNRs for the higher frequency notches.

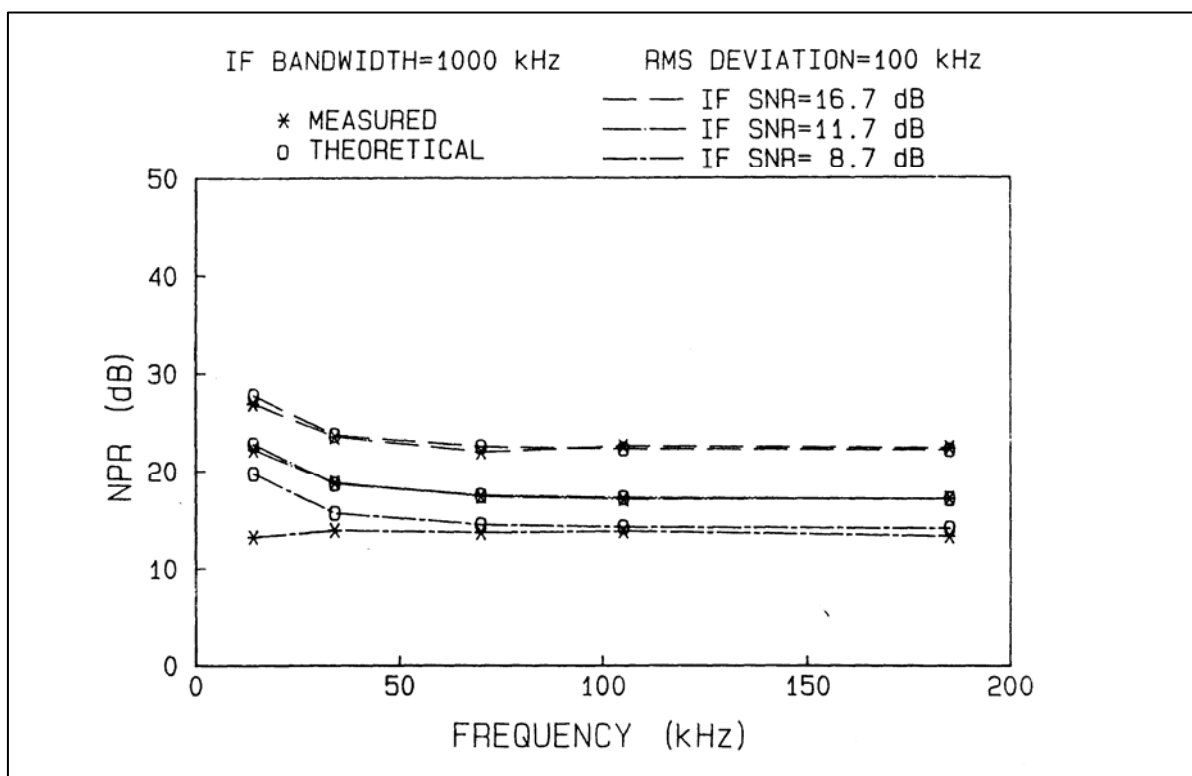

Figure 2-161. Measured and theoretical NPRs (1000 kHz IF, 100 kHz deviation).

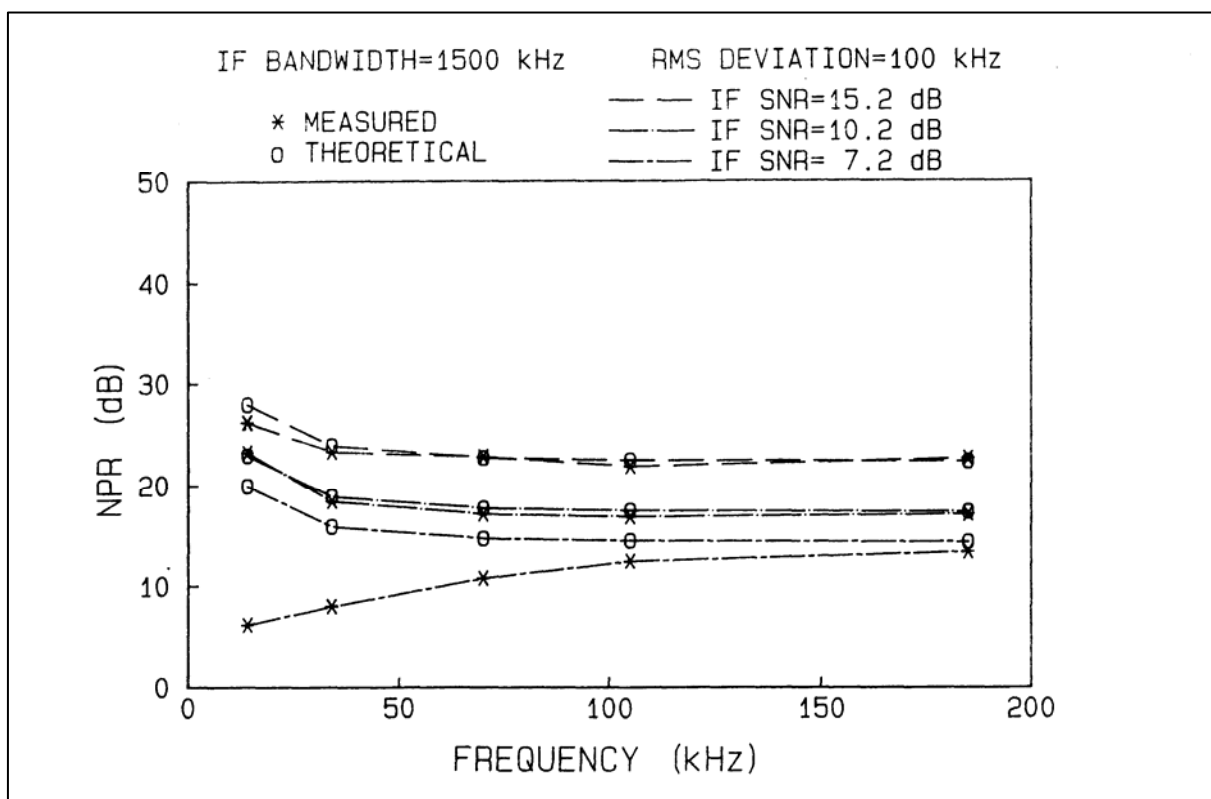

Figure 2-162. Measured and theoretical NPRs (1500 kHz IF, 100 kHz deviation).

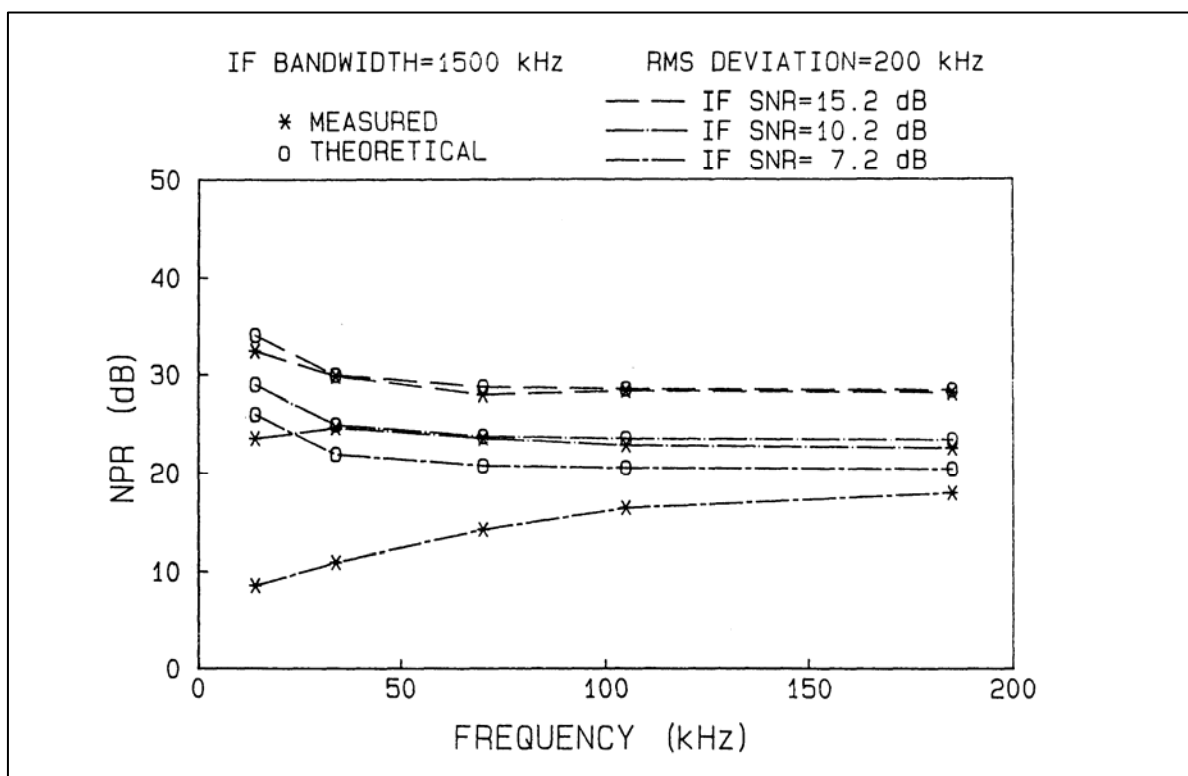

Figure 2-163. Measured and theoretical NPRs (1500 kHz IF, 200 kHz deviation).

2.9 Hybrid Systems

Hybrid systems are defined as systems in which more than one type of signal must be multiplexed together on the same transmitter. Hybrid systems can be designed and analyzed by using the information presented in subsections [2.2](#) through [2.8](#). An example of this is multiplexing subcarrier oscillators (SCOs) with a PAM or PCM signal on the same FM transmitter (Reference [2jj](#)). There are two ways of doing this:

- a. The PAM or PCM signal can be put on the baseband with the SCOs at a higher frequency.
- b. The SCOs can be at lower frequencies and the PAM or PCM signal can modulate another SCO.

An example of the first type of system would be a 256-kb/s randomized NRZ-L bit stream that needs to be transmitted along with two analog signals with 2 kHz of required bandwidth each. The baseband spectrum of such a system is shown in Figure [2-164](#). The SCO frequencies (± 8 kHz deviation) were chosen to be near the spectral null of the NRZ-L PCM signal.



CAUTION: The PCM signal may have components at the bit rate if there are glitches at the clock rate. The use of a subcarrier that includes the bit rate within its channel bandwidth should be approached with much caution.

The RF spectrum of this system is shown in Figure [2-165](#). The IRIG -60 dBc bandwidth is approximately 1.5 MHz, so this signal will fit in an IRIG narrow band (1 MHz) channel.

The BER versus IF SNR in a 256-kHz bandwidth is shown in Figure [2-166](#) for four IF bandwidths. It is interesting to note that the best PCM data quality is achieved with a 300-kHz IF bandwidth. This filter essentially rejects the two SCOs. The BER performance with all four filters is essentially what is expected without the SCOs. This suggests that with this type of transmitted signal, two receivers should be used. A receiver with an IF bandwidth approximately equal to the bit rate to recover the PCM signal, and a receiver with a wider IF bandwidth to recover the SCO data. The output of the wider bandwidth receiver should also be predetection recorded to increase the probability of getting the best possible data quality. The SNR at the output of a 288-kHz discriminator with a 2-kHz linear phase output filter at a 34-dB IF SNR (1 MHz IF bandwidth) was 48 dB (full-scale sine wave rms/noise rms). The SNR was 35 dB at a 12.5-dB IF SNR. The SNRs at the output of a 256-kHz discriminator were 55 dB and 35 dB at IF SNRs of 34 dB and 12.5 dB, respectively. For comparison purposes, the IF SNR in a 256-kHz bandwidth required to achieve a 10^{-5} BER with the 256-kb/s PCM signal modulating a 450-kHz SCO is approximately 19 dB (1.5 MHz IF bandwidth). The IRIG -60 dBc bandwidth would be approximately 3.5 MHz.

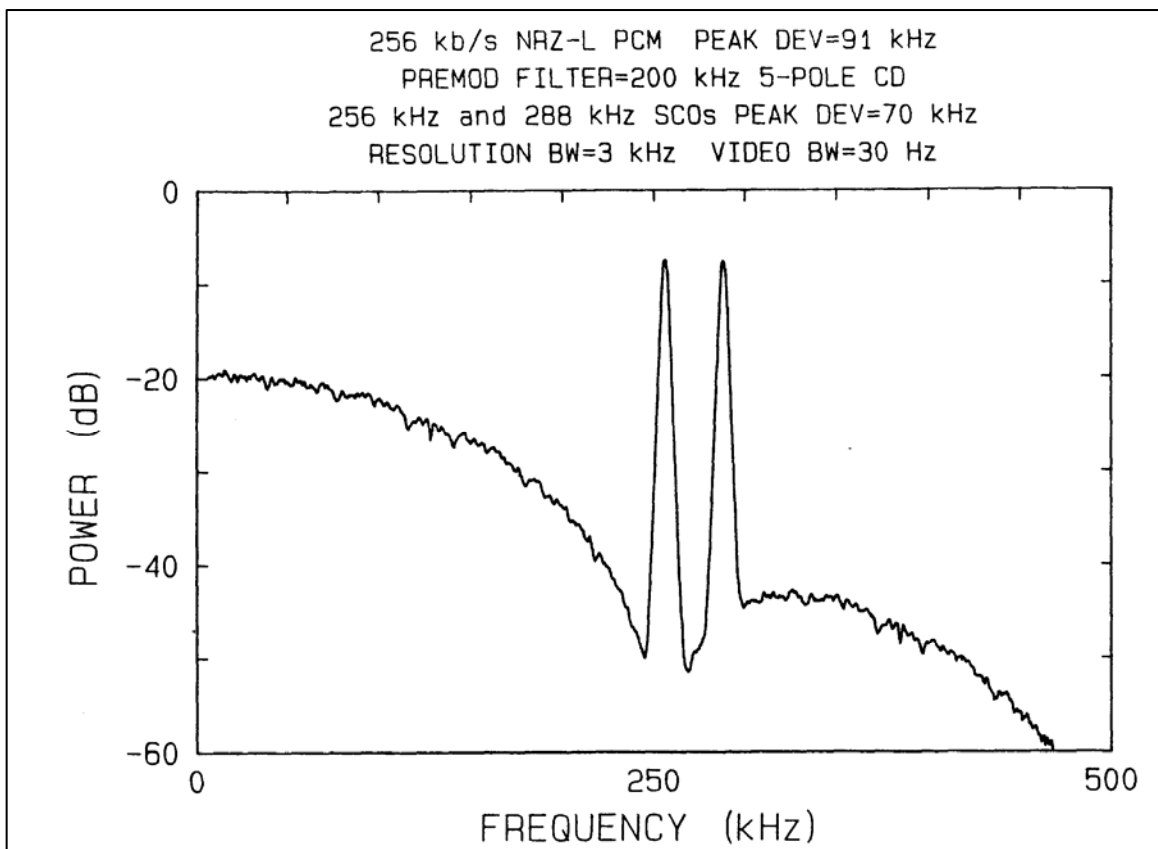

Figure 2-164. Baseband spectrum 256 kb/s NRZ with 2 SCOSs.

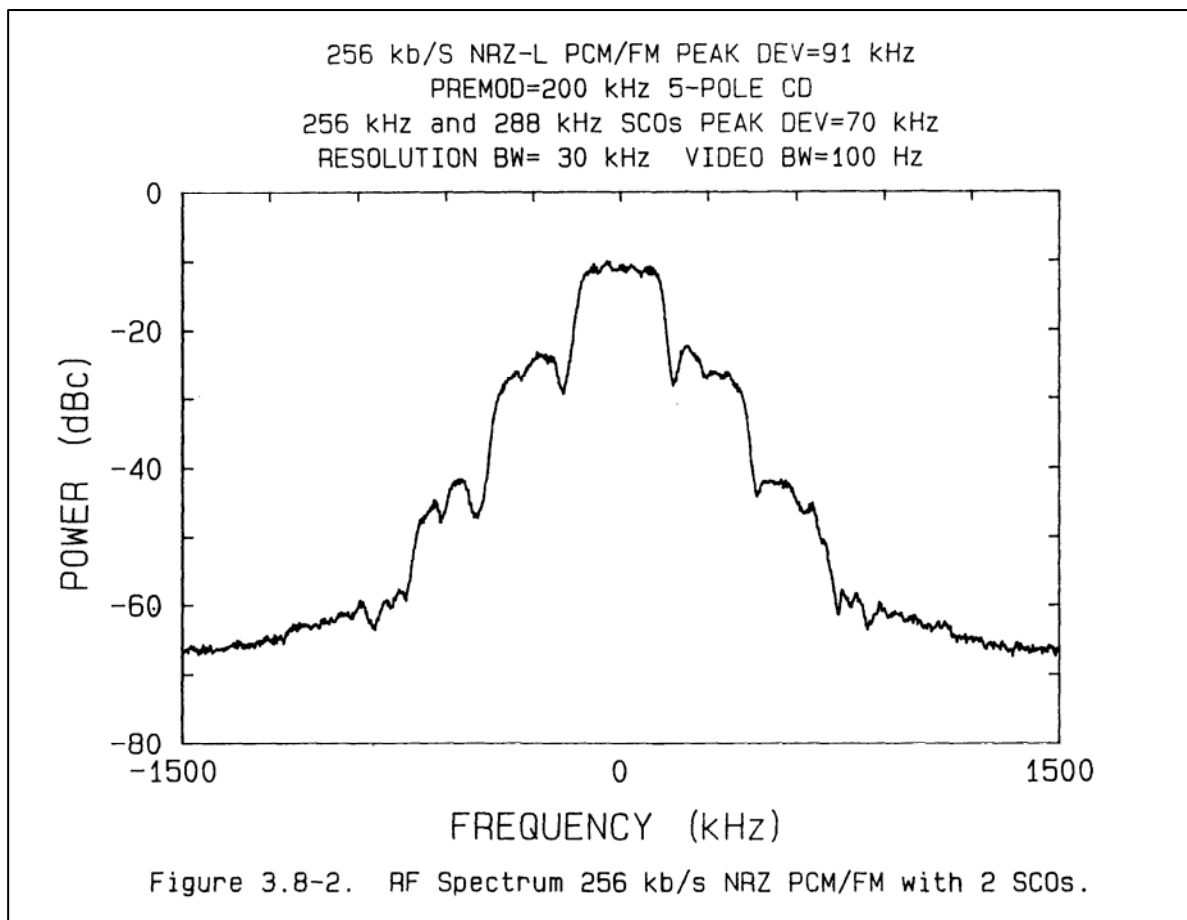

Figure 2-165. RF spectrum 256 kb/s NRZ PCM/FM with 2 SCOs.

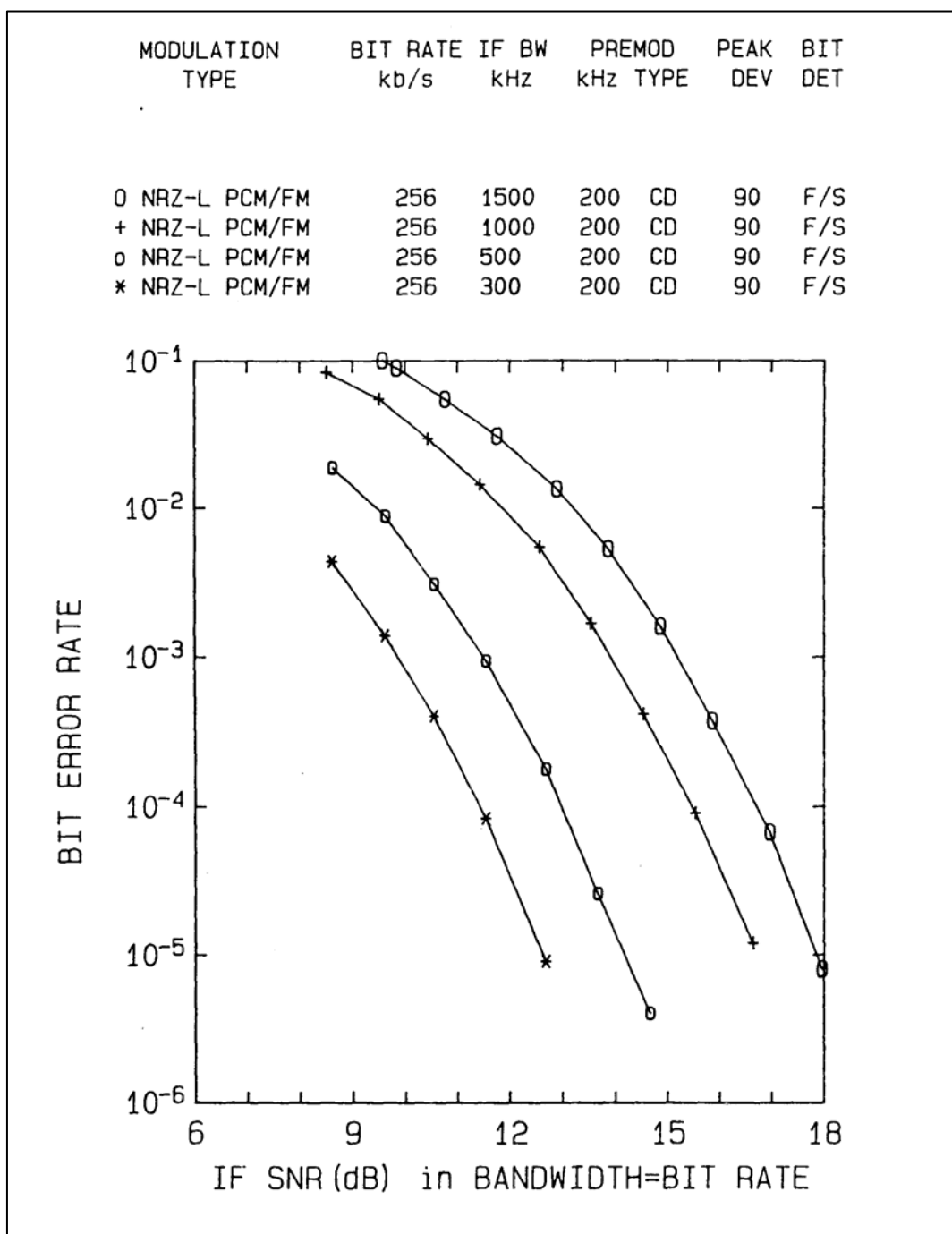

Figure 2-166. BER versus IF BW for 256 kb/s NRZ PCM/FM and 2 SCOs.

2.10 Link Analysis

2.10.1 **Introduction.** A typical telemetry link is shown in Figure [2-167](#). The parameters that are important in predicting the expected performance of the link include:

- a. Transmitter power
- b. Cable loss between transmitter and antenna
- c. Transmitting antenna gain, which is a function of direction and polarization and includes VSWR loss
- d. Communication channel losses that include free space propagation loss, multipath, and ducting
- e. Plume attenuation
- f. Atmospheric attenuation (rain, fog, etc.)
- g. Receiving antenna gain and noise temperature
- h. Preamplifier gain and noise temperature
- i. Telemetry receiver bandwidth and noise temperature
- j. Modulation method, error correction coding, and data type (FM, PM, PCM, PAM, FM/FM)
- k. Demodulation and detection methods
- l. Data bandwidth

Radio Horizon. The equations presented in this section all assume that the transmitting and receiving antennas are within radio line-of-sight of each other. Assume the standard value of $4/3$ for the ratio of effective earth radius to actual earth radius, the distance between the two antennas when they are at the radio horizon can be approximated by the following (See Reference [2kk](#)):

$$D = 5280 \left((2h_T)^{1/2} + (2h_R)^{1/2} \right) \text{ feet,} \quad (2-33)$$

where

$$\begin{aligned} h_T &= \text{height (feet) above mean local elevation (MLE) of transmitting antenna} \\ h_R &= \text{height (feet) above MLE of receiving antenna.} \end{aligned}$$

The above is illustrated in Figure [2-168](#) and Figure [2-169](#).

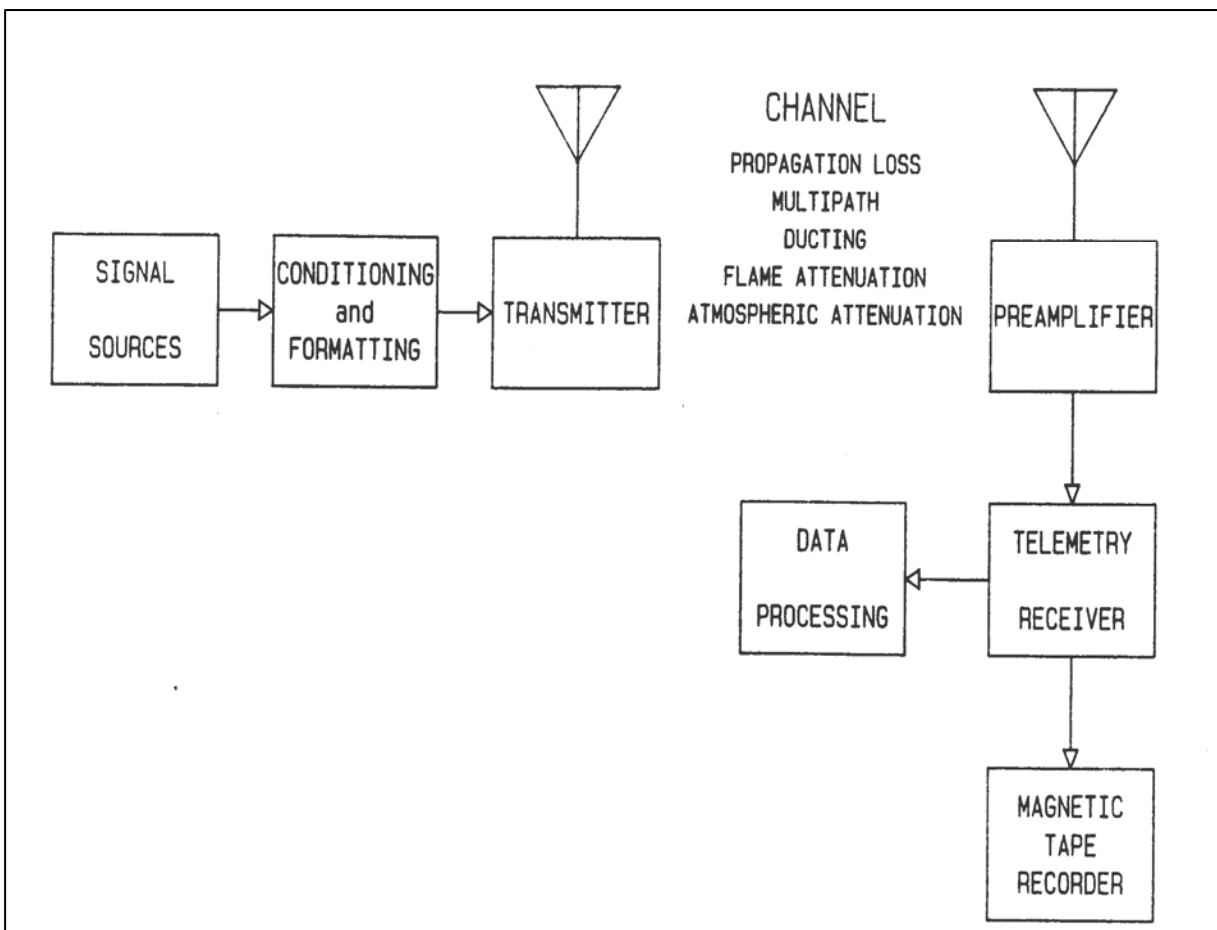

Figure 2-167. Block diagram of telemetry link.

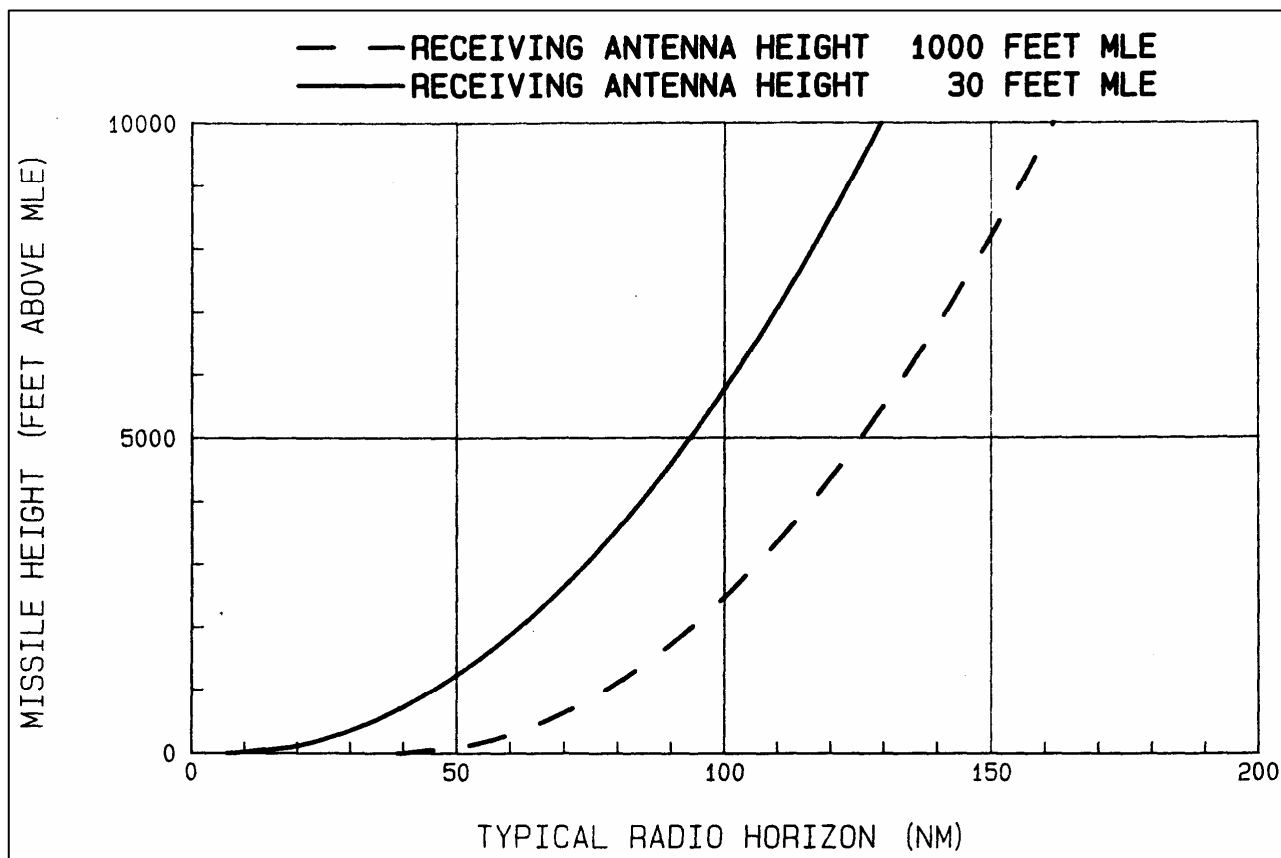

Figure 2-168. Typical radio horizon for transmitter less than 10,000 feet above MLE.

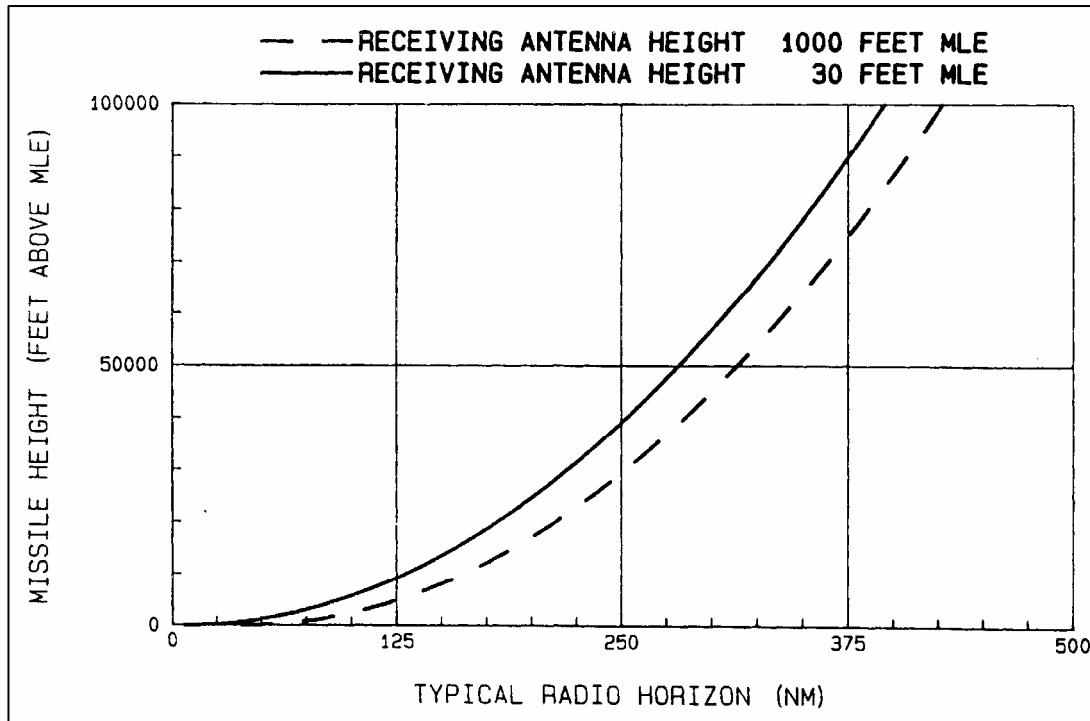

Figure 2-169. Typical radio horizon for transmitter less than 100,000 feet above MLE.

2.10.2 Transmitting System.

2.10.2.1 Transmitter Power. The transmitter power is frequently determined by the available battery power. Most missile telemeters have transmitter powers between 1 and 10 watts. The transmitter power is expressed in dBm in the equations in this section (1 watt = +30 dBm).

2.10.2.2 Cable Loss. The loss of commonly used cables is typically 0.14 to 0.2 dB/foot at 2.25 GHz.

2.10.2.3 Transmitting Antenna Gain. The transmitting antenna gain is usually expressed in dBi. Zero dBi is defined as the gain of a 100 percent efficient antenna, which radiates power equally in all directions. The transmitting antenna gain is usually measured in an anechoic chamber. The gain is measured in all directions by rotating the transmitting antenna relative to the measurement antenna, which is usually a linear horn or a circularly polarized antenna. Measurements are commonly made for vertical and horizontal or left hand circular and right hand circular polarizations. Typical missile telemetry antenna gains vary from +6 dBi to less than -40 dBi depending on the direction and polarization. Typical missile transmitting antenna gains (circular polarization) that are exceeded over a given percent of the sphere surrounding the missile are:

| Coverage Percent | Gain |
|------------------|----------|
| 90 | - 12 dBi |
| 95 | - 16 dBi |
| 99 | - 22 dBi |

This means that for a typical missile telemetry antenna 10 percent of the time the gain of left hand circular polarization is less than -12 dBi. These gains can be increased by typically 5, 7, and 9 dB at 90, 95, and 99 percent coverage using polarization diversity combining. Diversity signal combining is discussed in paragraph [4.4](#). These values vary for different types of missiles and will be different even if only using a part of the transmitting antenna pattern. For example, if missiles will always be fired away from a particular receiving site only the rear hemisphere is of interest. Missile transmitting antennas are typically linearly polarized and telemetry-receiving antennas are typically circularly polarized. The use of this polarization combination tends to minimize the reception problems that can occur when receiving data from maneuvering missiles

2.10.3 Communication Channel Losses.

2.10.3.1 Free Space Propagation Loss. The effective free space propagation loss can be calculated using

$$L_p = \left(\frac{4\pi D}{\lambda} \right)^2 20 \log \quad (2-34)$$

where

L_p is expressed in dB

λ = wavelength = c/f = speed of light/transmitted frequency

c = 3.00x10⁸ meters/sec. or 9.82x10⁸ feet/sec.

D = distance between transmitting and receiving antennas

D and λ must be in the same units.

If $f = 2250$ MHz and $D = 1000$ meters, then

$$L_p = 20 \log \left\{ \frac{4\pi 1000}{3 \times 10^8 / 2.25 \times 10^9} \right\} = 99.5 \text{ dB.}$$

If $f = 2250$ MHz and $D = 5280$ feet, then

$$L_p = 103.6 \text{ dB.}$$

A commonly used formula is

$$L_p \text{ (dB)} = 36.6 + 20 \log f + 20 \log D,$$

where f is expressed in MHz and D is expressed in statute miles.

2.10.3.2 Multipath. Multipath occurs when the signal arrives at the receiving antenna by the direct path and by one or more secondary paths (see chapter 28 of reference [2kk](#)). Multipath losses can vary from a gain of 6 dB (-6 dB loss) or more if the signals add in-phase to a loss of 30 dB or more if the signals add out-of-phase. Multipath can be reduced by using a more directional antenna, by careful selection of mission profiles, and by use of diversity reception.

Null steering antennas can also be used for multipath reduction, but they are not available at telemetry-receiving facilities at this time. A multipath channel model for wideband aeronautical telemetry links is presented in “Wideband Channel Model for Aeronautical Telemetry” (Reference [2ll](#)). This channel model is based on experiments performed at Edwards AFB, CA. The channel could be accurately modeled by three propagation paths: a line-of-sight path and two specular reflections. One specular reflection has a relative amplitude of 70 to 96 percent of the line-of-sight amplitude with a delay of 10 to 80 ns; the other has a relative amplitude of 2 to 8 percent of the line-of-sight amplitude and a mean excess delay of 155 ns with an rms delay spread of 74 ns. The multipath characteristics may differ somewhat at other test ranges, but the information contained in this paper provides a starting point for multipath analysis.

2.10.3.3 Ducting. Ducting is a phenomenon where an electromagnetic wave is trapped between layers in the atmosphere that have a steep gradient in their index of refraction (see chapter 28 of Reference [2kk](#)). This can cause a signal which is beyond the radio horizon to be received clearly or, conversely, cause a nearby signal to be greatly attenuated. Ducting can be predicted from measurements of the refractive index of the atmosphere; however, ducting loss is usually not included in link calculations.

2.10.3.4 Plume Attenuation. Plume attenuation occurs when the signal passes through the ionized gas cloud, which is produced, by a variety of rocket boosters. The signal amplitude and phase are both modulated by passage through the ionized gas cloud. The modulation rates can be in the tens of kilohertz (see Reference [2mm](#)) and the attenuation can exceed 30 dB. The left and right hand circularly polarized components of the signal are not modulated identically by the passage through the ionized gas cloud; therefore, a diversity combiner with wideband weighting signals can significantly improve the data quality during plume attenuation.

2.10.3.5 Atmospheric Attenuation. Propagation through the atmosphere does not cause significant signal attenuation at frequencies between 1.4 and 2.3 GHz even during heavy rainstorms. An atmospheric attenuation of 1 dB is frequently assumed in these bands.

2.10.4 Receiving System

2.10.4.1 Receiving System Sensitivity. The receiving system sensitivity is usually characterized by measuring the ratio of antenna gain to receiving system noise temperature (G/T) (see Chapter [4](#)). This is expressed in decibels per degree Kelvin (dB/°K). The G/T of moderate size dishes (4 to 40 foot diameter) is usually measured by using the sun as a calibrated signal source. This method is described in RCC Document 118. Typical values of G/T for a modern receiving system with a 7 meter dish are 14 to 16 dB/°K at 1.5 GHz and 18 to 20 dB/°K at 2.25 GHz, when the antenna is pointed at least 5 degrees above the local horizon. The G/T is lower at lower elevation angles because the main lobe of the antenna starts to "see" the warm Earth in addition to the cold sky. This increases the system noise temperature.

The sensitivity of the receiving system can also be calculated by knowing the gain and noise figure of each element of the system (see paragraph [4.3](#)). The solar calibration method is preferred because the G/T can be measured in a few minutes any time the sun is above the local horizon. The measured G/T provides an excellent measure of the current "health" of the receiving system.

2.10.4.2 Telemetry Receiver Bandwidth. The telemetry receiver bandwidth is needed to determine the total system noise power and the signal-to-noise ratio needed to achieve a desired data quality. The equivalent noise power bandwidth is usually within ± 10 percent of the quoted receiver IF bandwidth, so the IF bandwidth can usually be used with an error of less than 0.5 dB. The total noise power is equal to kTB , where

$$\begin{aligned} k &= -198.6 \text{ dBm}/^\circ\text{K/Hz (Boltzmann's constant)} \\ T &= \text{system noise temperature (}^\circ\text{ K)} \\ B &= \text{bandwidth (Hz)}. \end{aligned}$$

However, we have included T in the G/T term so we will only use kB for the noise contribution. The “best” bandwidth to use in the calculation is determined by the modulation method and the detection method. For analog FM and PCM/FM with a traditional FM demodulator plus single bit detection the IF bandwidth is usually the best bandwidth to use. For PCM/FM with multi-symbol detection or any modulation method with a coherent demodulator the bit rate is the best bandwidth to use (the signal energy per bit to noise power spectral density ratio (E_b/N_o) is equivalent to the IF SNR in a bandwidth equal to the bit rate).

2.10.4.3 SNR for Desired Data Quality. The SNR or E_b/N_o required to achieve a given data quality is a function of the modulation method, data type, data bandwidth, and receiver bandwidth. This is discussed in paragraphs 2.2 through 2.8 for various modulation methods. For example, if we need a BER of 10^{-5} for 700 kb/s NRZ-L PCM/FM and the receiver bandwidth is 1000 kHz, and we are using FM demodulation with single bit detection, the required IF SNR is 12 dB in a 1000 kHz bandwidth. If you are unsure of what IF SNR is needed, 12 dB is usually a good estimate for most FM applications. However, if the best multi-symbol detector is used then the E_b/N_o required is about 9 dB, which is equivalent to an IF SNR of 7.5 dB which is a 4.5 dB improvement.

2.10.5 Link Margin Calculation. The predicted signal is equal to transmitter power - cable loss + transmitting antenna gain - path loss - multipath loss - ducting loss - plume attenuation - atmospheric attenuation + receiving system antenna gain. The predicted noise is equal to Boltzmann's constant + receiving system temperature + receiver IF bandwidth (all quantities in dB). Combining the receiving system antenna gain and noise temperature into one term (G/T), we get the following equation for predicted SNR:

$$\text{SNR}_p = P_T - L_C + G_T - L_p - L_M - L_D - L_F - L_A + G/T - kB \quad (2-35)$$

where

- SNR_p is the predicted IF SNR (or is the predicted E_b/N_o if B =bit rate)
- P_T is the transmitter output power in dBm
- L_C is the cable loss between the transmitter and the transmitting antenna
- G_T is the gain of the transmitting antenna in dBi
- L_p is the path loss in dB
- L_M is the estimated multipath loss in dB
- L_D is the estimated ducting loss in dB

L_F is the estimated plume attenuation in dB
 L_A is the estimated atmospheric loss in dB
 G/T is the receiving system figure of merit in dBi per degree Kelvin
 k_B is Boltzmann's constant times the equivalent noise power bandwidth

Link margin is defined as the excess SNR available in the link. It is calculated by subtracting the desired SNR from the predicted SNR. A sample calculation is shown for a system with the following parameters:

| | |
|--|----------------|
| Transmitter frequency | 2250.5 MHz |
| Transmitter power | 5 watts |
| Data type | NRZ-L PCM/FM |
| Bit rate | 5 Mb/s |
| Cable loss between transmitter and antenna | 1 dB |
| Required probability of "good" data | 95 percent |
| Desired data quality | 10^{-5} BER |
| Receiving system G/T | 18 dB/°K |
| Receiving system IF bandwidth | 6000 kHz |
| Maximum range | 100 kilometers |
| Antenna elevation angle | 2° |

Other assumptions:

| | |
|-------------------------|--|
| Multipath loss | 5 dB |
| Plume attenuation | 10 dB single polarization 7 dB diversity combined |
| Atmospheric attenuation | 1 dB |
| Ducting loss | 0 dB |

This gives the following values:

| | |
|--------|--|
| P_T | +37 dBm (5 watts) |
| L_C | 1 dB |
| G_T | -16 dBi (LHC only) -9 dBi (LHC +RHC) |
| L_p | 139.5 dB |
| L_M | 5 dB |
| L_D | 0 dB |
| L_F | 10 dB (LHC only) 7 dB (LHC + RHC) |
| L_A | 1 dB |
| G/T | 17 dB/°K (1 dB loss for 2° elevation angle) |
| k_B | -131.6 dB/°K (5000 kb/s bandwidth) |
| SNR | 12 dB (E_b/N_o for 10^{-5} BER with 5 Mb/s NRZ-L PCM/FM and 6000 kHz IF bandwidth). |
| Margin | = $SNR_p - SNR$ |

$$\text{LHC Margin} = +37 -1 -16 -139.5 -5 -0 -10 -1 +17 +131.6 -12 = 1.1 \text{ dB}$$

$$(\text{LHC} + \text{RHC}) \text{ Margin} = +37 -1 -9 -139.5 -5 -0 -7 -1 +17 +131.6 -12 = 11.1 \text{ dB}$$

The embedded spreadsheet Link-119.xls allows one to vary parameters in a link analysis. For instance, one can type a new value into E2 to change the center frequency.

2.11 Relay Systems

2.11.1 Introduction. There are several types of relay systems. These include both analog and digital point-to-point microwave links, relay aircraft, and airborne relay pods that receive signals that may be over the horizon from the telemetry ground station, fiber optic cable systems, and RF cable systems.

Microwave links are frequently used to send data from the receiving site to the real-time data processing site. Both analog and digital microwave links are used. The analog links use either the received predetection or video signals for the modulation link inputs. Most analog microwave links multiplex several telemetry signals on one microwave link and have fairly limited bandwidth. This presents a problem with wideband signals because coordination is required between the range user and the microwave link personnel to determine if there are potential bandwidth problems with the user's telemetry system. Most digital microwave links use intelligent asynchronous multiplexer/demultiplexers, which allow several asynchronous digital telemetry signals to be multiplexed together and sent over one microwave link. The signals are then demultiplexed at the receiving end of the microwave link.

There are three major methods used in telemetry relay systems:

- a. Frequency translation of the original signal
- b. Demodulation of the original signal followed by modulation of a new carrier
- c. Demodulation and reconstruction of the original signal followed by modulation of a new carrier.

An example of the first method would be to mix the final IF output of a telemetry receiver with a local oscillator to produce a new signal at the desired frequency. This method preserves the deviation and frequency response characteristics of the original transmitted signal if the bandwidths of the receiver and translation system are wide enough. The signal-to-noise effects of this method are discussed later in this subsection.

An example of the second method would be to use the demodulated video output of a telemetry receiver to modulate a second transmitter. This method preserves the characteristics of the original transmitted signal only if the demodulator sensitivity and the transmitter sensitivity are the same and the bandwidths are wide enough to pass the signal without attenuation. The signal and noise effects are discussed later in this subsection.

An example of the third method would be to follow the receiver video output with a bit synchronizer. The bit synchronizer output would modulate the second transmitter. The deviation is now determined by the combination of the bit synchronizer output amplitude, the gain of any filter section between the bit synchronizer output and the transmitter, and the deviation sensitivity of the transmitter. The system bit error rate (BER) is the sum of the BERs in links 1 and 2. Any error extension would apply equally to the errors generated in any link affected by the encoder/decoder causing the error extension.

2.11.2 Translation Relay SNR Calculation. The SNR in a given bandwidth at the output of a system that consists of an originating transmitter, a receiver, a translation of the receiver IF to a second RF frequency and transmission of the resulting signal, and a final receiver (Figure 2-170) is calculated in this section.

Assume that the signal (the units of S and N are power) at IF₁ can be represented by

$$S_1 + N_1$$

and the signal at IF₂ can be represented by

$$A (S_1 + C (N_1)) + N_2$$

where

S₁ is the signal power at the IF output of receiver #1

N₁ is the noise power at the IF output of receiver #1

N₂ is the noise power at the IF output of receiver #2 because of the downlink only

C = B_{IF2} / B_{IF1} except C is never greater than 1

A is the net gain between the IF output of receiver #1 and the IF output of receiver #2

B_{IF1} is the equivalent noise power bandwidth of receiver #1 (uplink receiver)

B_{IF2} is the equivalent noise power bandwidth of receiver #2 (downlink receiver)

The IF SNR of just the downlink is A (S₁) / (N₂).

The IF SNR of the entire link is then

$$\frac{A(S_1)}{A(C(N_1)) + N_2} = \frac{(SNR_1) \times (SNR_2)}{(SNR_1) + C(SNR_2)}$$

Therefore, the predicted IF SNR of the entire link can be calculated from the predicted IF SNRs of the uplink and the downlink and the ratio of the IF bandwidths of the receivers.

If C = 1 and the IF SNRs of both the uplink and the downlink are 20 dB, then

$$SNR_1 = 100 \text{ and } SNR_2 = 100$$

$$\text{System IF SNR} = \frac{100 \times 100}{100 + 100} = 50 \text{ or } 17 \text{ dB.}$$

If C = 0.5 SNR₁ = 10 and SNR₂ = 100, then

$$\text{System IF SNR} = \frac{10 \times 100}{10 + 100/2} * 16.67 \text{ or } 12.2 \text{ dB}$$

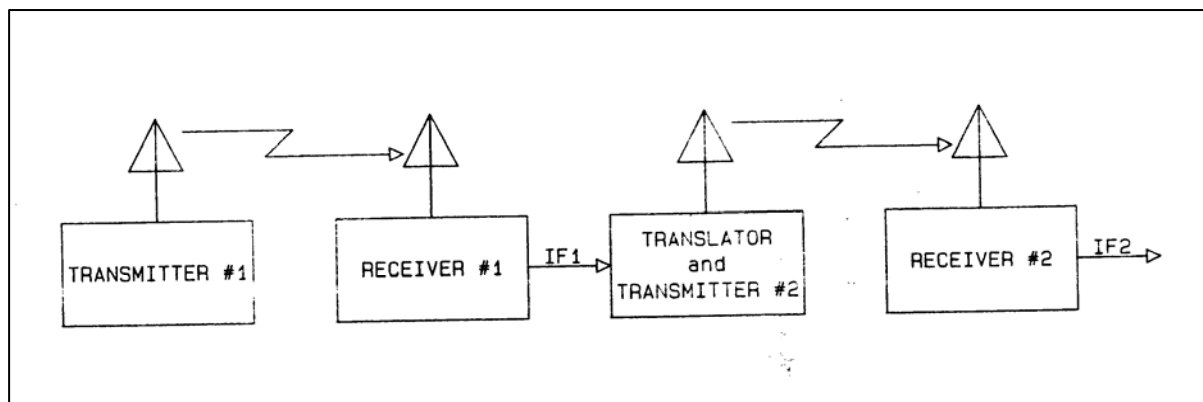

Figure 2-170. Block diagram of translation relay link.

2.11.3 FM Demodulation/Remodulation Relay SNR Calculation. The video SNR at the output of an FM system which consists of an originating transmitter, a receiver, a second transmitter, and a second receiver (see Figure 2-171) is calculated in this section. The analysis presented here assumes that both links are above FM threshold. The method is valid below FM threshold but the equations for signal and noise are not. This means that these equations should not be used if the IF SNR of either link is below 12 dB. The actual system video SNR will be worse than predicted by these equations if the IF SNR of either link is below 12 dB.

$$\text{Signal at video 1 is } S_{v1} = (K_1 \Delta f_1)^2 / 2$$

$$\text{Noise at video 1 is } N_{v1} = (K_1 f)^2 / (\text{SNR}_{\text{IF1}} B_{\text{IF1}})$$

Where

S_{v1} is the signal power at the input to transmitter 2

N_{v1} is the noise power at the input to transmitter 2

K_1 is the demodulator sensitivity (V/kHz) of demodulator 1

Δf is the peak deviation of transmitter 1

f indicates the video frequency

SNR_{IF} is the IF SNR expressed as a power ratio

B_{IF} is the receiver equivalent noise power bandwidth.

Assume

K_2 is the modulation sensitivity (V/kHz) of transmitter 2

K_3 is the demodulator sensitivity (V/kHz) of demodulator 2.

The signal at video 2 is then $S_{v2} = (K_3 / K_2)^2 S_{v1}$

Noise at video 2 is $N_{v2} = (K_3 / K_2)^2 N_{v1} + (K_3 f)^2 / (\text{SNR}_{\text{IF2}} B_{\text{IF2}})$

$$\text{System video SNR} = S_{v2} / N_{v2}$$

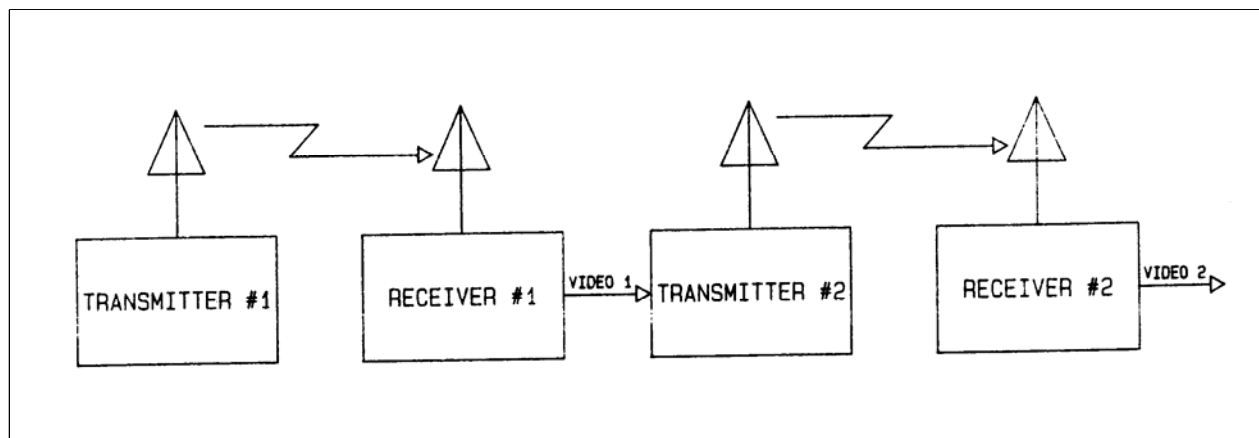

Figure 2-171. Block diagram of demodulation/remodulation relay link.

2.12 Frequency Modulation (FM) Noise Characteristics

The two major types of noise signals present at the output of a frequency modulation (FM) demodulator are commonly called fluctuation noise and pop or click noise (see References [2nn](#), [2oo](#), and [2pp](#)). Fluctuation noise is defined as the error in the demodulated output caused by a noise vector being summed with the signal vector where the instantaneous noise amplitude is smaller than the signal amplitude. Pop noise is defined as the error in the demodulated output that occurs when the instantaneous vector sum of the signal plus noise encircles the origin. (The noise amplitude has to be equal to or greater than the signal amplitude for this to occur.)

A vector diagram illustrating fluctuation noise is presented in Figure [2-172](#). The amplitude of the noise is 20 percent of the amplitude of the signal in Figure 2-172. This limits the time rate of change of the angle ϕ , which is the FM demodulator output error signal. The signal vector is assumed stationary and the noise vector rotates with respect to the signal vector in this model. If we further assume that the instantaneous frequency of the noise is 400 kHz lower than the signal frequency, we can plot the vector sum and the demodulator error as a function of time. Figure [2-173](#) presents the sum of a signal with amplitude of 1 at a frequency of 10 MHz, and noise with an amplitude of 0.2 with a frequency of 9.6 MHz. The dots show the signal with no noise. The initial and final vector relationship is as shown in Figure 2-172. Figure [2-174](#) shows the demodulator error signal for these conditions. In the real-world, the amplitude, phase, and frequency of the noise are random variables. The largest error is slightly larger than +100 kHz and occurs when the vectors are antiparallel. The mean value of the error is zero. Fluctuation noise dominates at high IF signal-to-noise ratios (SNRs), which are above approximately 12 dB.

Fluctuation noise is characterized as having a Gaussian amplitude distribution and a power spectrum proportional to

$$f^2 N_0(f) / (A_c)^2$$

where

- f = frequency of the noise
- $N_0(f)$ = noise power spectral density at input to demodulator
- A_c = amplitude of the signal.

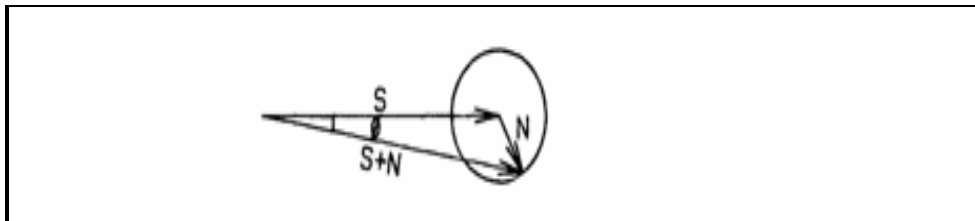

Figure 2-172. Fluctuation noise vector diagram for $N=0.2S$.

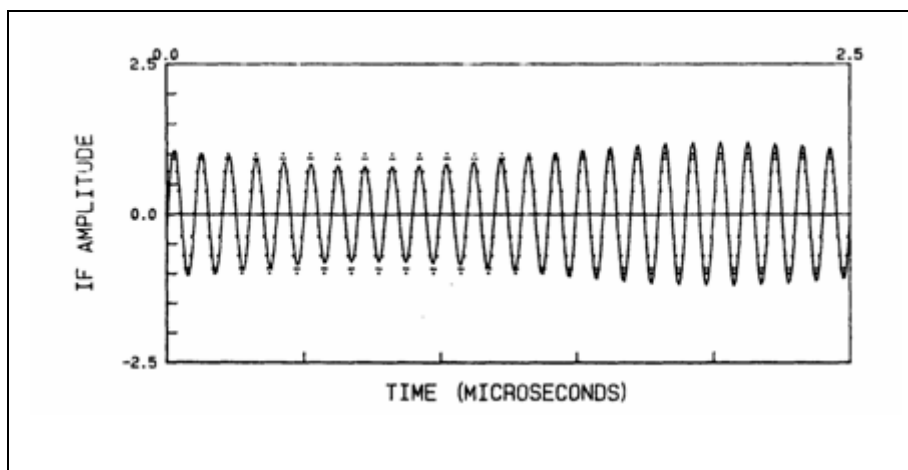

Figure 2-173. IF Amplitude ($N=0.2s$).

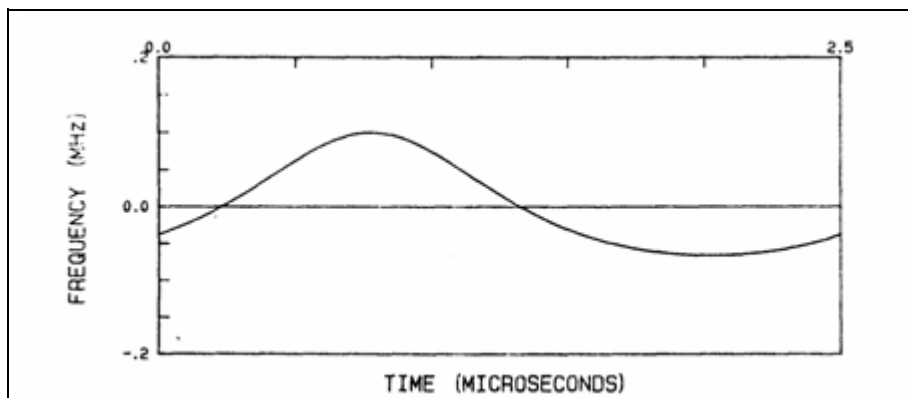

Figure 2-174. Demodulator output for $N=0.2S$.

Therefore, the fluctuation noise at the output of the demodulator increases at 6 dB per octave when $N_0(f)$ is constant, assuming no video filter. The frequency response characteristic of the IF filter is the main factor which determines $N_0(f)$. Examples of typical IF filter bandpass characteristics are shown in Figure [2-175](#), Figure [2-176](#) and Figure [2-177](#). A time domain plot of fluctuation noise is shown in Figure [2-178](#) and a spectral plot is shown in Figure [2-179](#).

Pop noise occurs when the instantaneous vector sum of the signal plus noise encircles the origin causing a rapid change of 2π radians in the angle $\phi(t)$ (see Figure [2-180](#)). The signal amplitude in Figure 2-180 is 1 while the instantaneous noise amplitude is 1.1. If the signal frequency is defined to be 10 MHz and the instantaneous noise frequency to be 9.6 MHz, a time record of the IF amplitude can be generated for one cycle of ϕ (see Figure [2-181](#)). Note that almost a full cycle of the 10-MHz signal (represented by dots) occurs between zero crossings of the vector sum of the signal plus noise when the amplitude of the signal plus noise is at a minimum, which causes the large pulse shown in Figure [2-182](#). The energy contained in the center of the spike (0.34 microsecond duration) is π radians or 1/2 cycle. The signals shown in Figure 2-181 and Figure 2-182 do not include any effects of IF bandpass filtering or video filtering. The effect of these filters would be to slow down the time rate of change of the demodulated output and reduce the total energy. Figure [2-183](#) and Figure [2-184](#) show an actual noise "pop" and the corresponding linear IF signal. The test conditions included a 1-MHz IF bandwidth and 500 kHz/volt demodulator sensitivity for both figures. The video bandwidth was 1 MHz for Figure 2-183 and 500 kHz for Figure 2-184. The sudden change in $\phi(t)$ causes a narrow pulse with an area of approximately 2π radians to be generated. This amount of energy is the same that would be contained in an unfiltered PCM/FM bit with a peak deviation equal to the bit rate. The noise pops are usually in the direction to cause bit errors in PCM/FM. The average frequency of the noise is usually near the center frequency of the IF filter, and as a result, when the carrier is deviated to a frequency which is higher than the center frequency, the instantaneous noise frequency will usually be lower than the signal frequency. This causes the pops to be in the direction towards the center frequency (see Figure [2-185](#) and Figure [2-186](#)). Each pop will usually cause a bit error for PCM/FM with a peak deviation less than the bit rate. Figure [2-187](#) shows a noise pop that is in the direction away from the center frequency. The noise can also capture the demodulator for a long enough time to cause multiple cycles of $\phi(t)$. The multiple cycles are especially likely to occur when the carrier is deviated away from the center frequency, causing a noise pop with area approximately equal to the number of cycles of $\phi(t)$. The FM demodulator output with a center frequency input was 0 volts dc and the demodulator sensitivity was 625 kHz/volt (see Figure [2-184](#) through Figure [2-190](#)).

Figure [2-188](#) and Figure [2-189](#) show the differences that occur in pop amplitude. The variation in pop amplitude is further illustrated by the superposition of several pops in Figure 2-190 and Figure [2-191](#). The test conditions for Figure 2-190 were IF SNR = 10 dB, IF bandwidth = 1 MHz, video bandwidth = 500 kHz, and RF input frequency = center frequency - 250 kHz. The amplitude of the pops varies greatly. The test conditions for Figure 2-191 and Figure [2-192](#) were IF SNR = 10 dB, IF bandwidth = 10 MHz, video bandwidth = 6 MHz, demodulator sensitivity = 4 MHz/volt, and RF input frequency = center frequency. The area of all non-doublet pops was approximately 1 cycle under these conditions. Doublet pops are shown in Figure 2-192 and Figure [2-193](#). Doublets occur when the noise does not capture the demodulator for a long enough time to complete a 2π swing of $\phi(t)$. Doublets have an area of approximately zero.

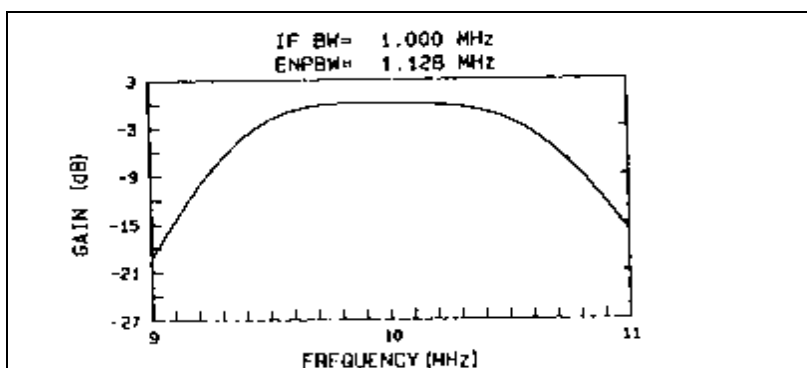

Figure 2-175. IF filter frequency response (Filter A).

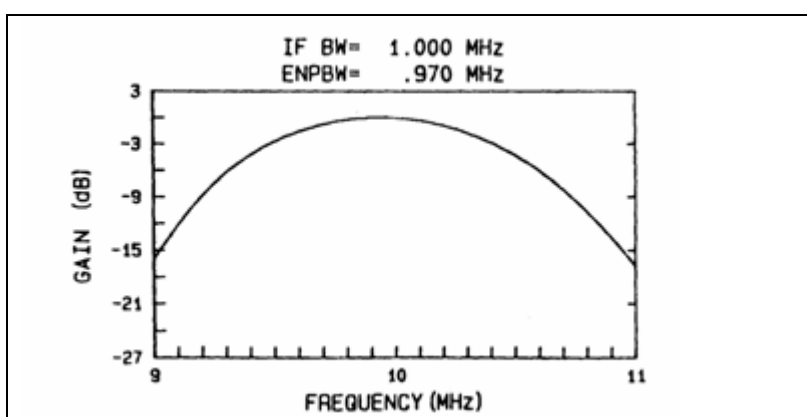

Figure 2-176. IF filter frequency response (Filter B).

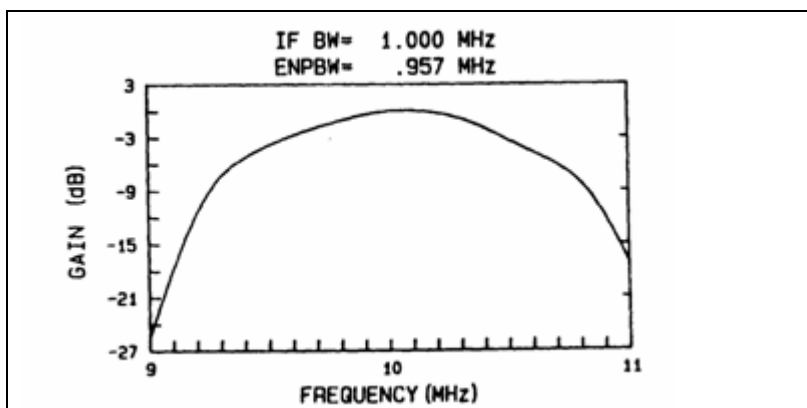

Figure 2-177. IF filter frequency response (Filter C).

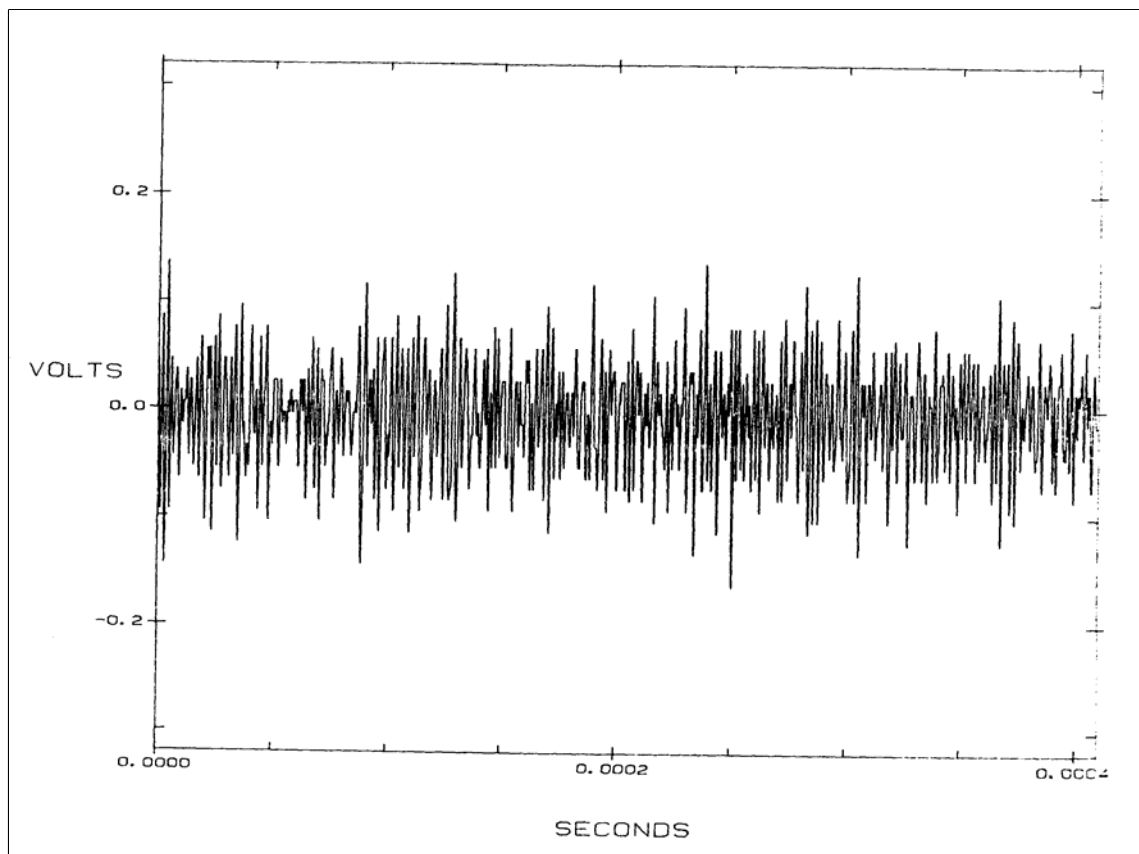

Figure 2-178. Fluctuation noise.

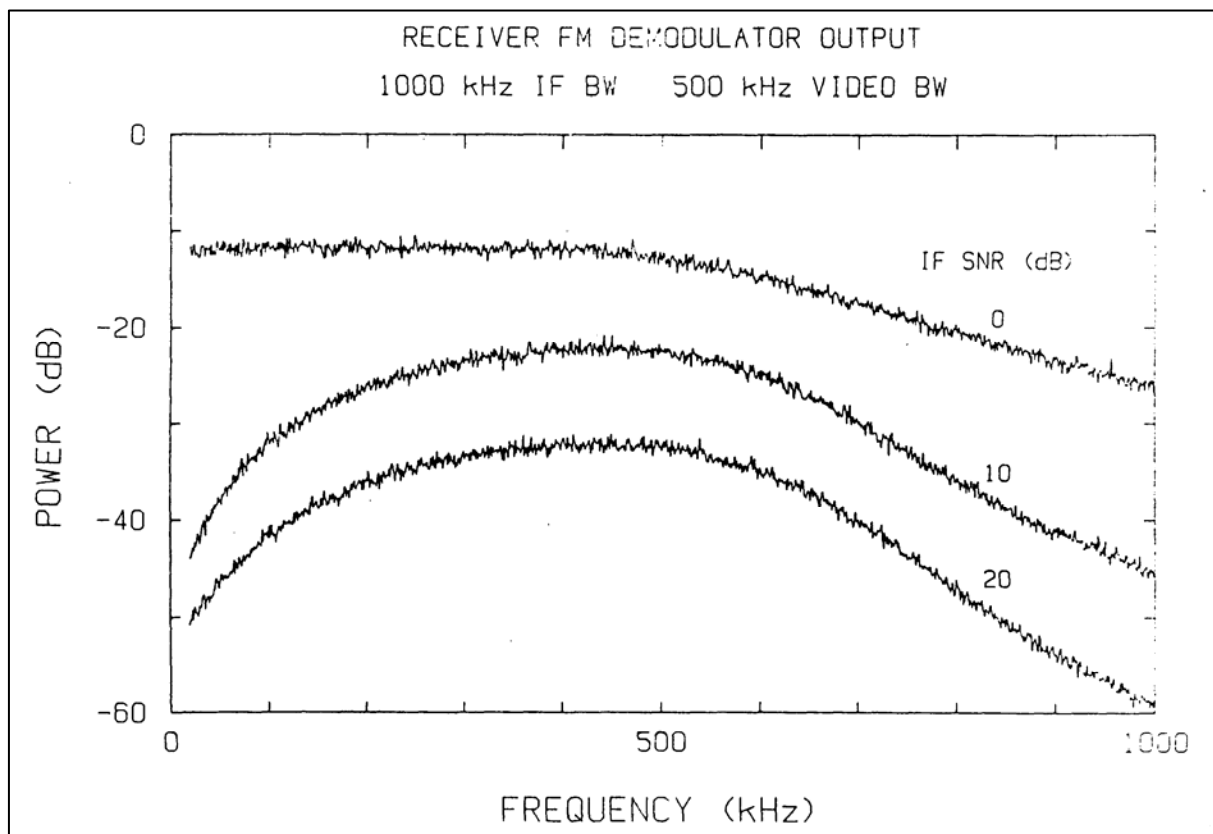

Figure 2-179. Receiver video noise power spectral density.

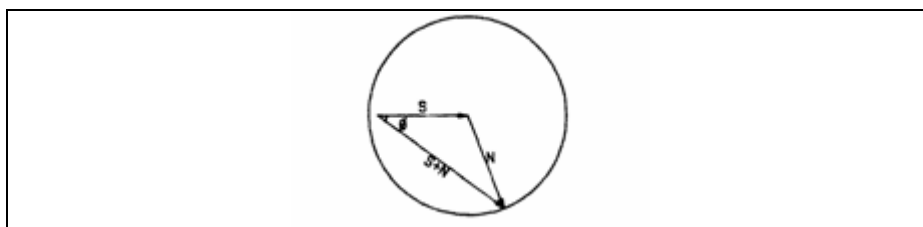

Figure 2-180. Vector diagram of pop noise (N=1.1S).

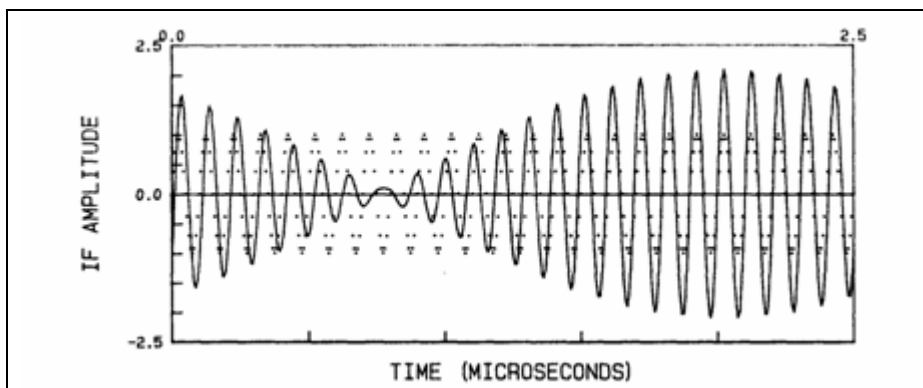

Figure 2-181. IF amplitude (N=1.1S).

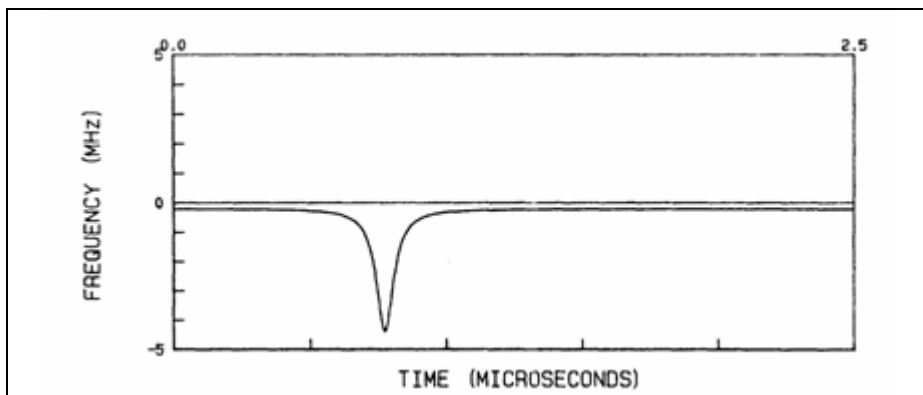

Figure 2-182. Demodulator output (N=1.1S).

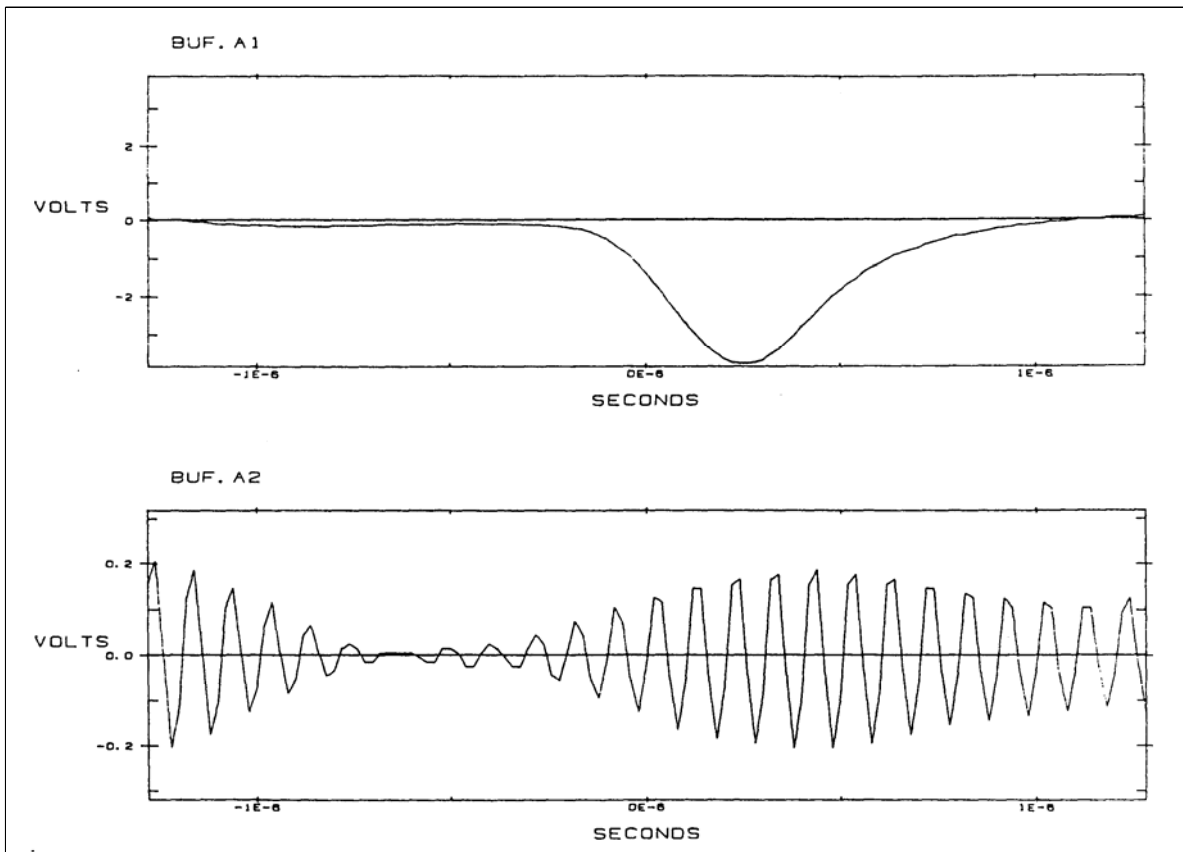

Figure 2-183. Noise pop (Upper trace video BW = 1 MHz) and IF signal.

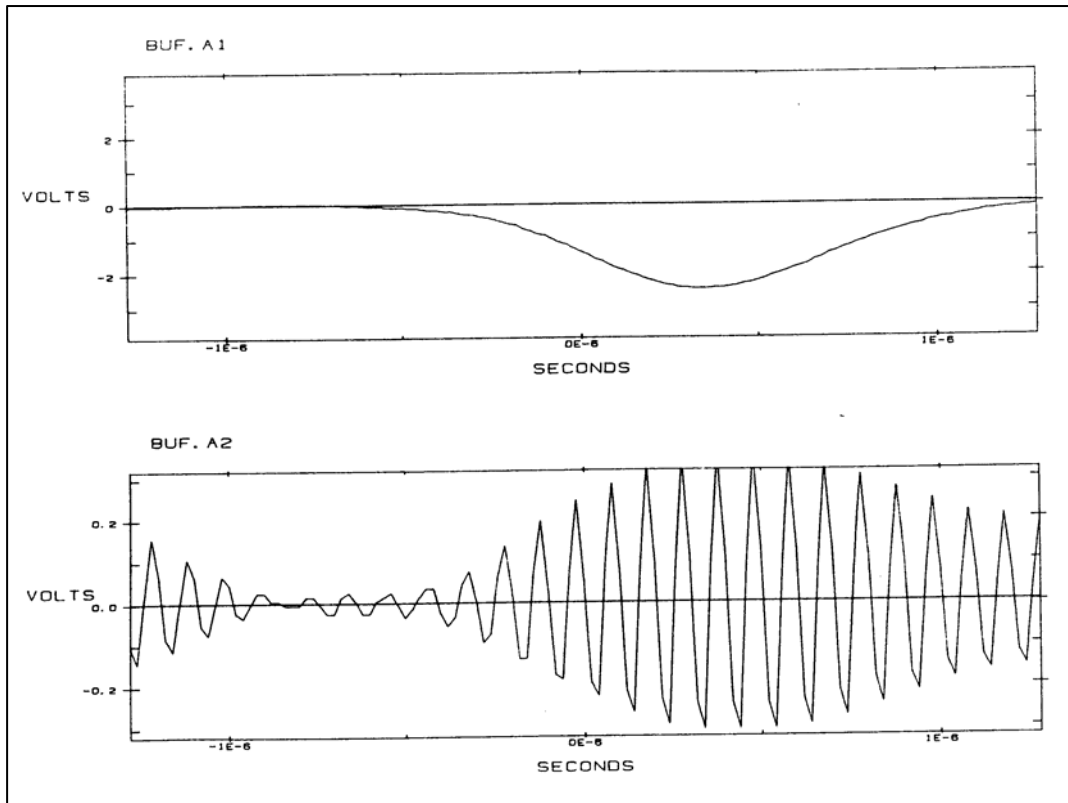

Figure 2-184. Pop noise (Upper trace video BW = 500 kHz) and IF signal.

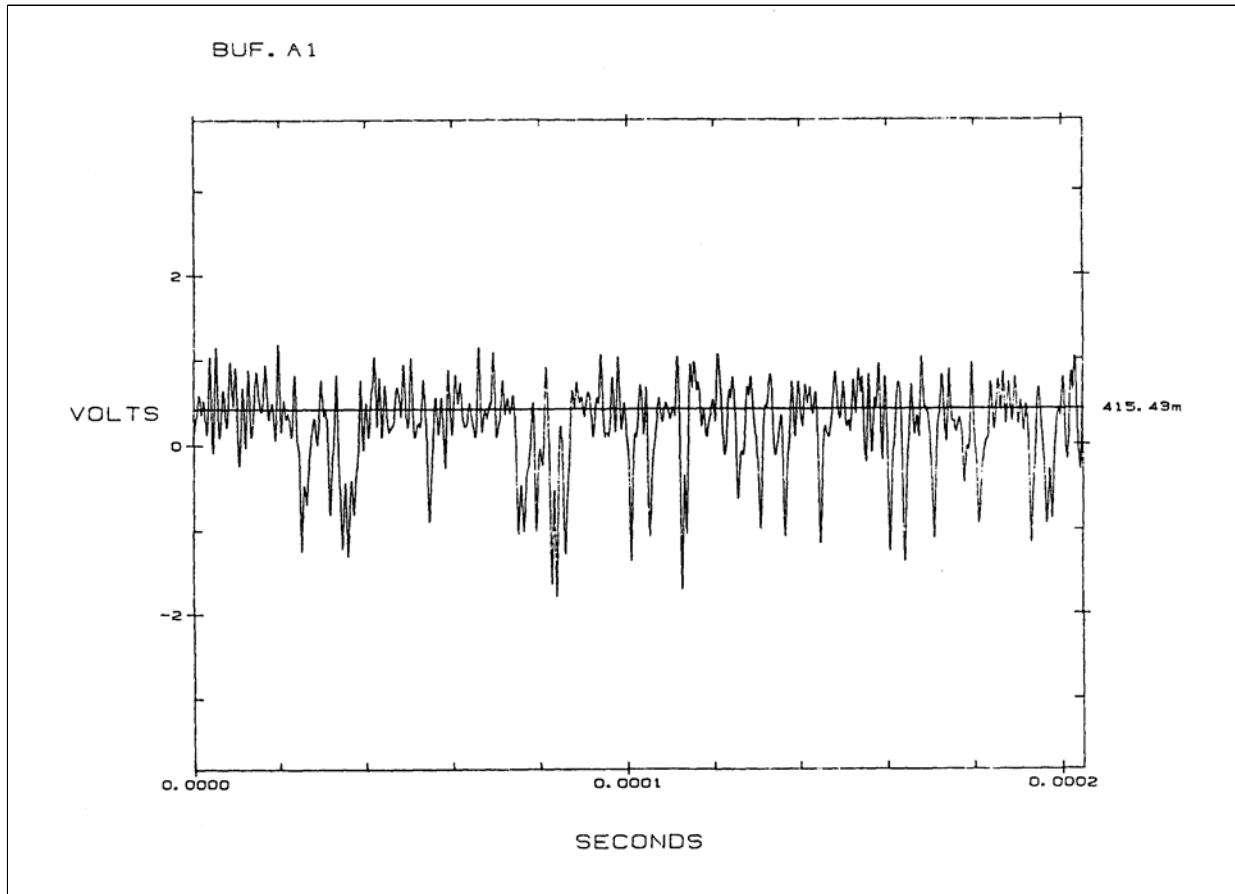

Figure 2-185. Pop noise with IF signal = 10.25 MHz.

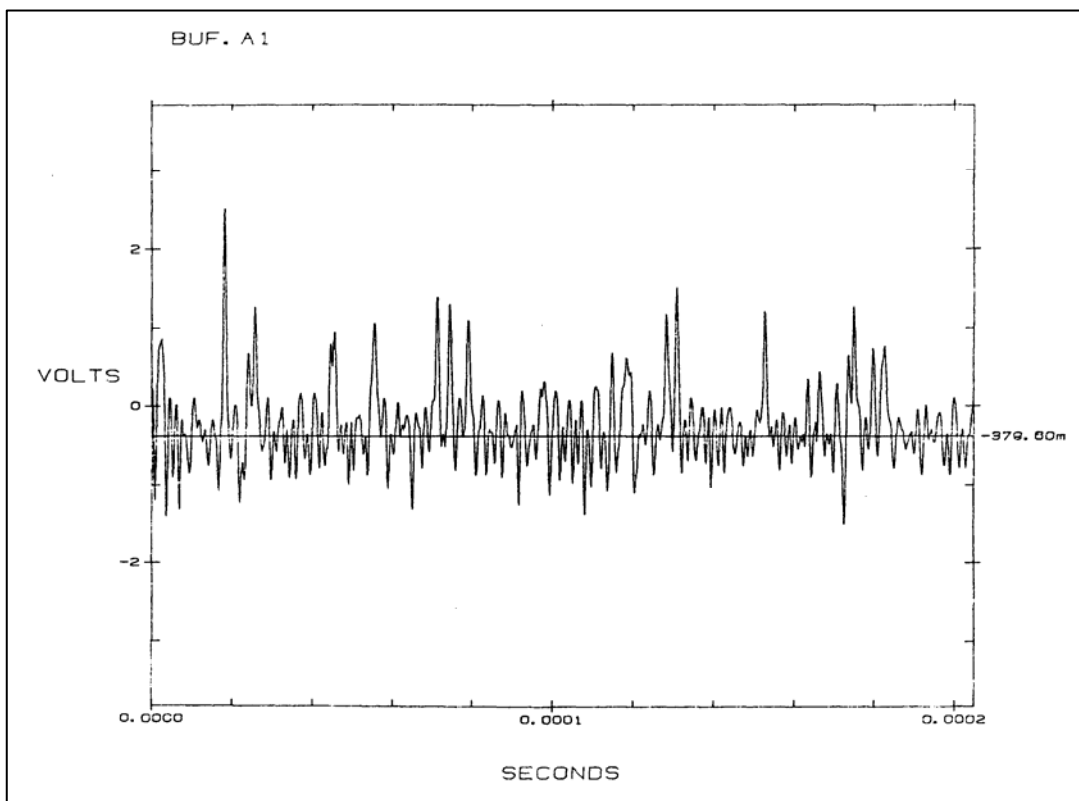

Figure 2-186. Pop noise with IF signal = 9.75 MHz.

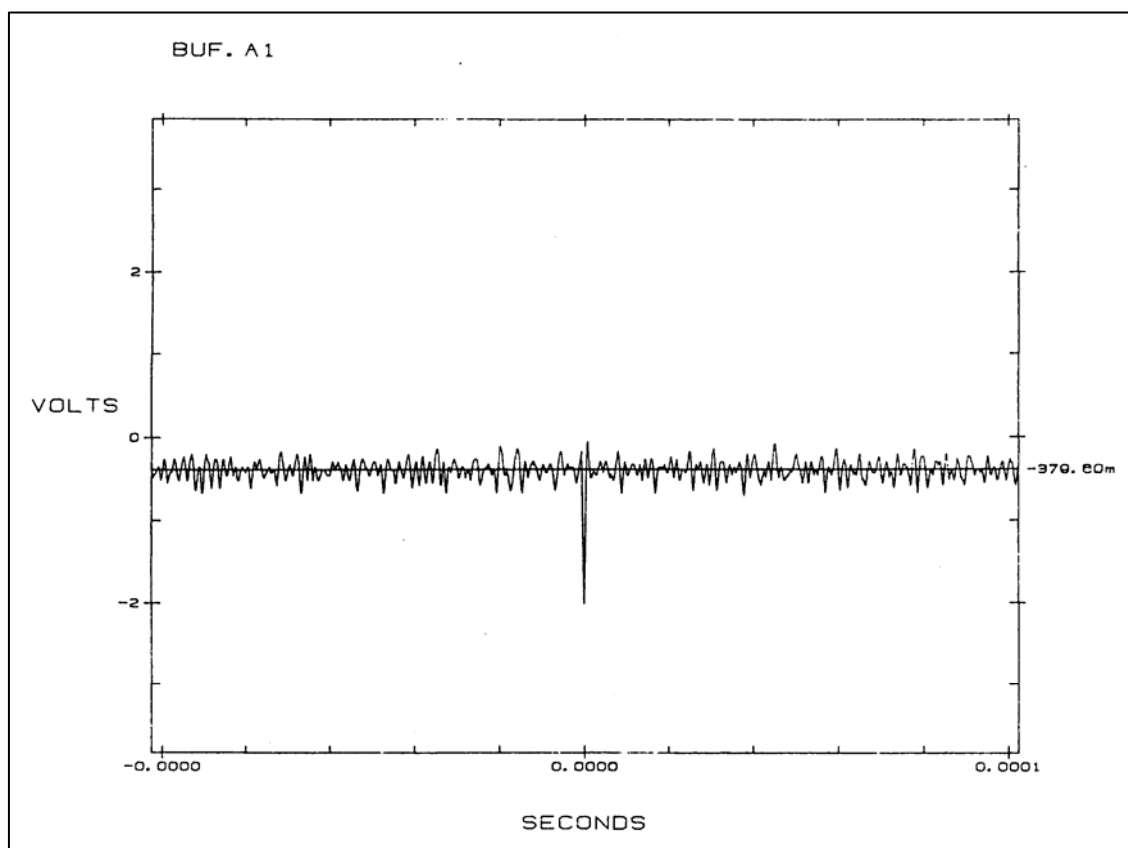

Figure 2-187. Noise pop away from center frequency.

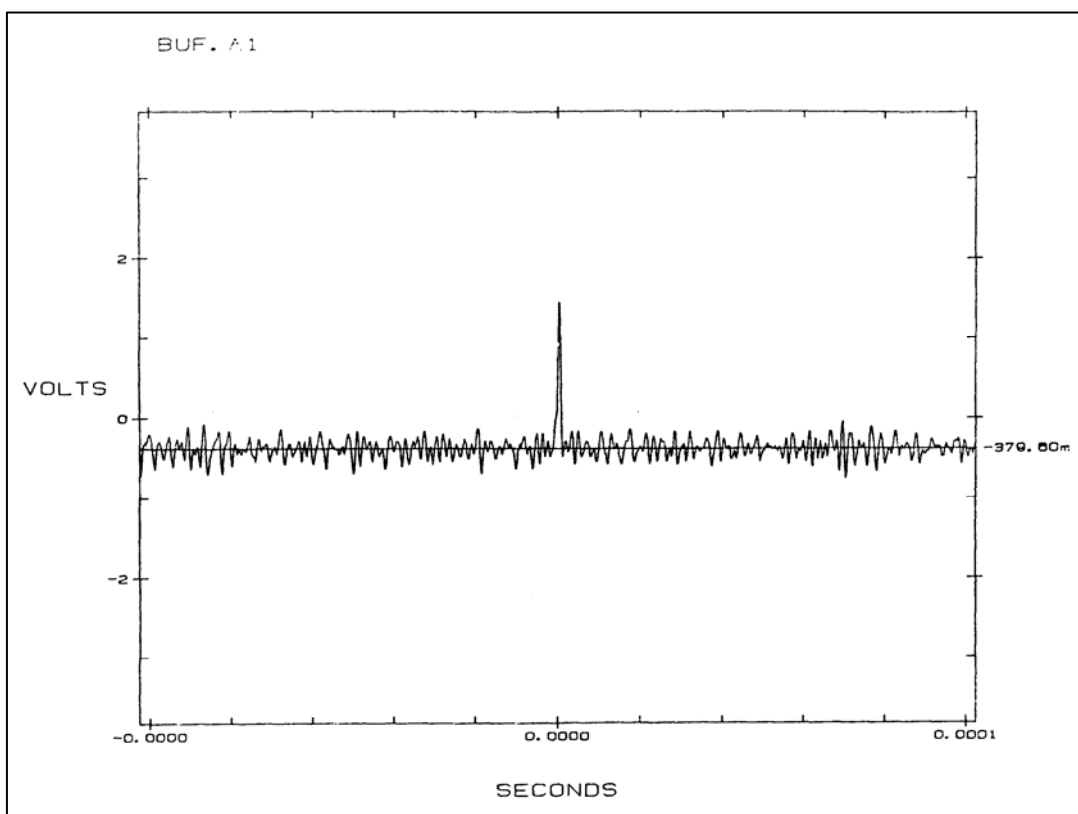

Figure 2-188. Noise pop with area = 2 PI.

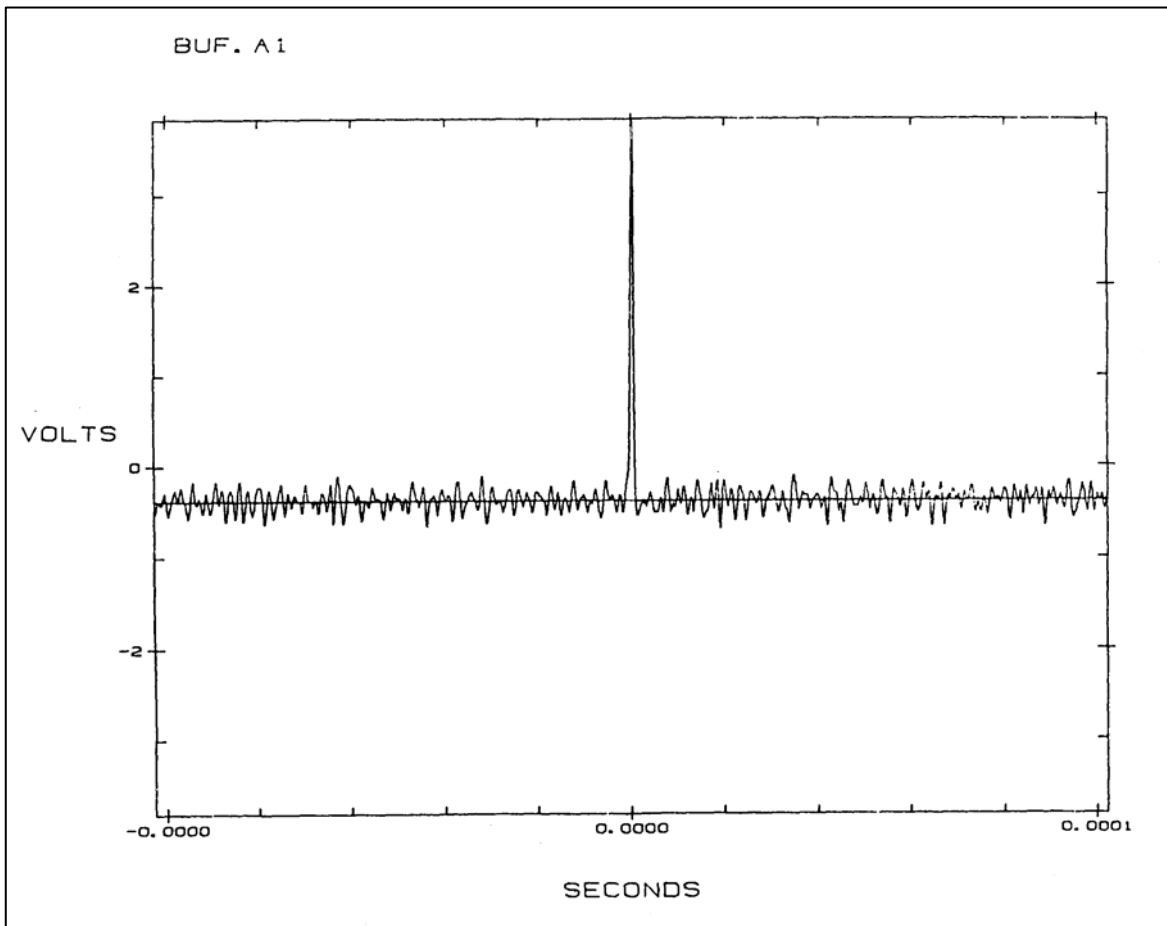

Figure 2-189. Noise pop with Area > 2 PI.

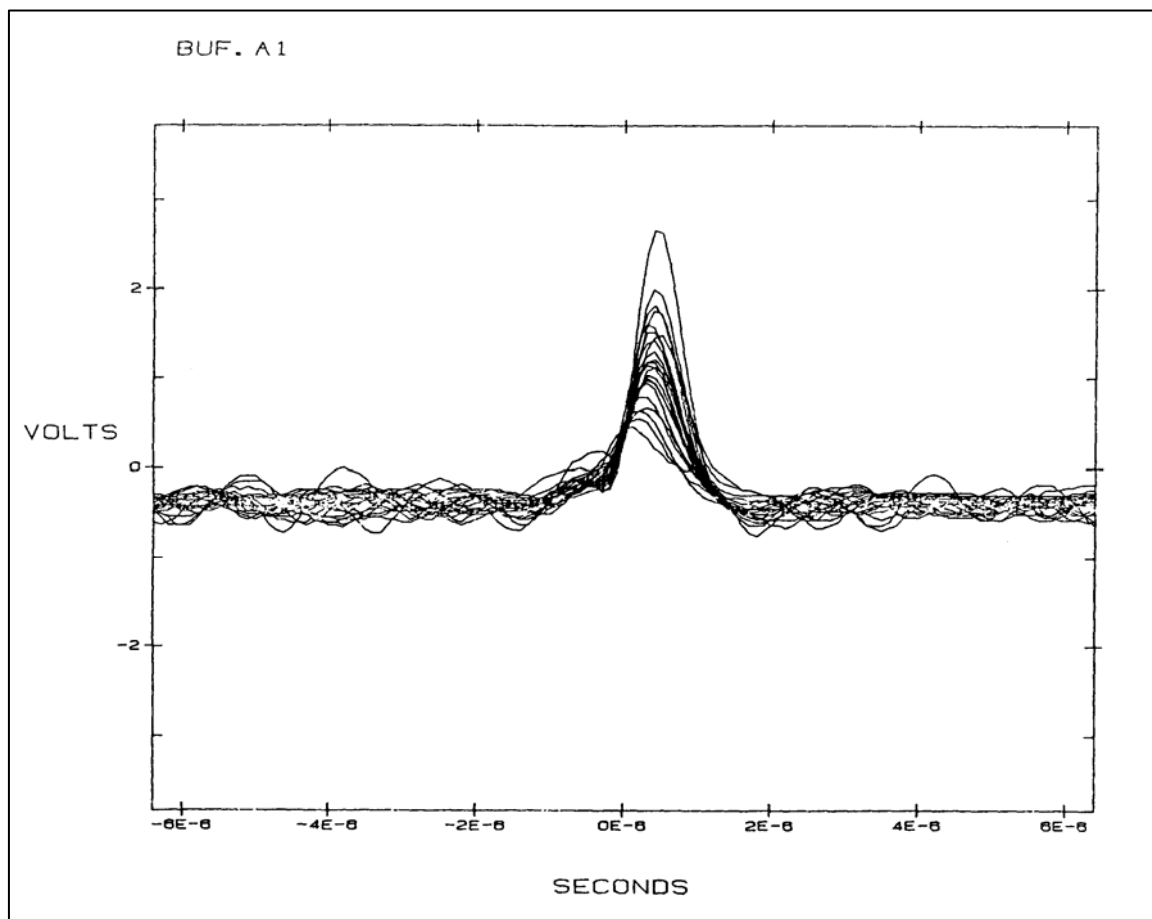

Figure 2-190. Superposition of several noise pops (IF bandwidth = 1 MHz).

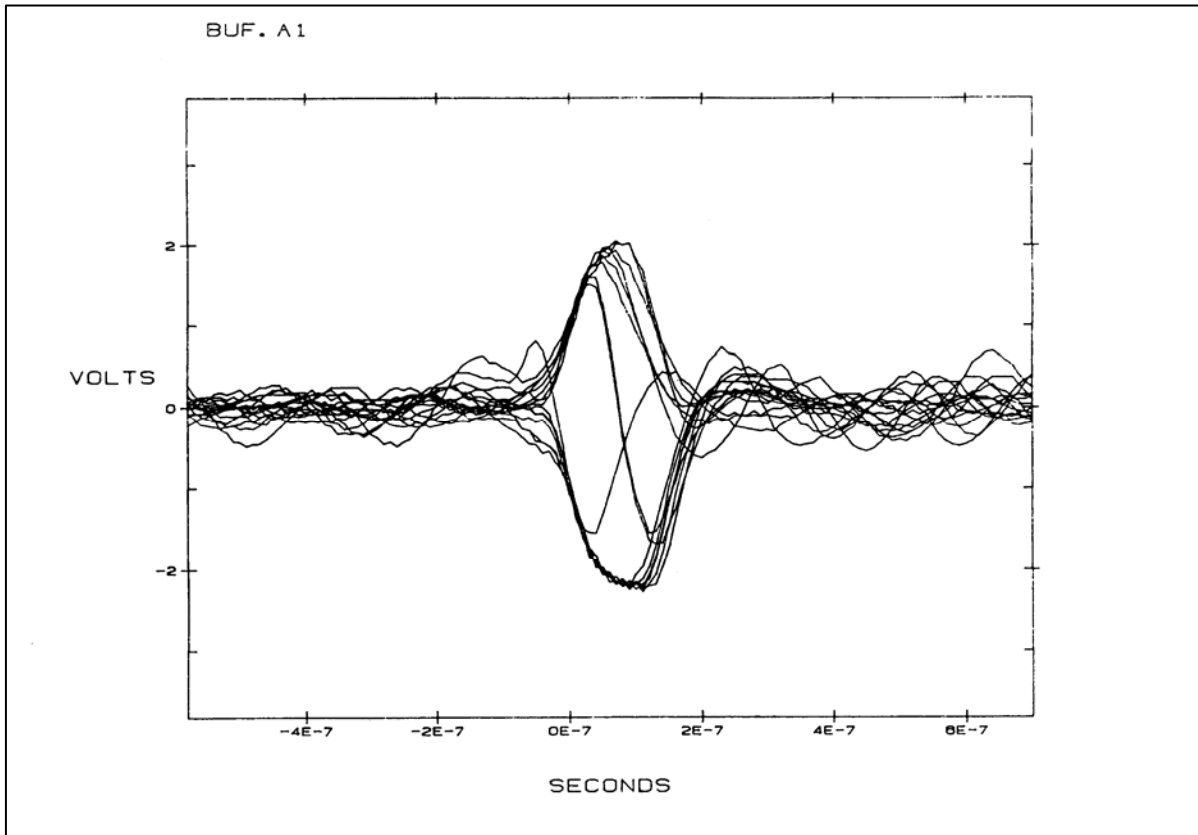

Figure 2-191. Superposition of several noise pops (IF bandwidth = 10 MHz).

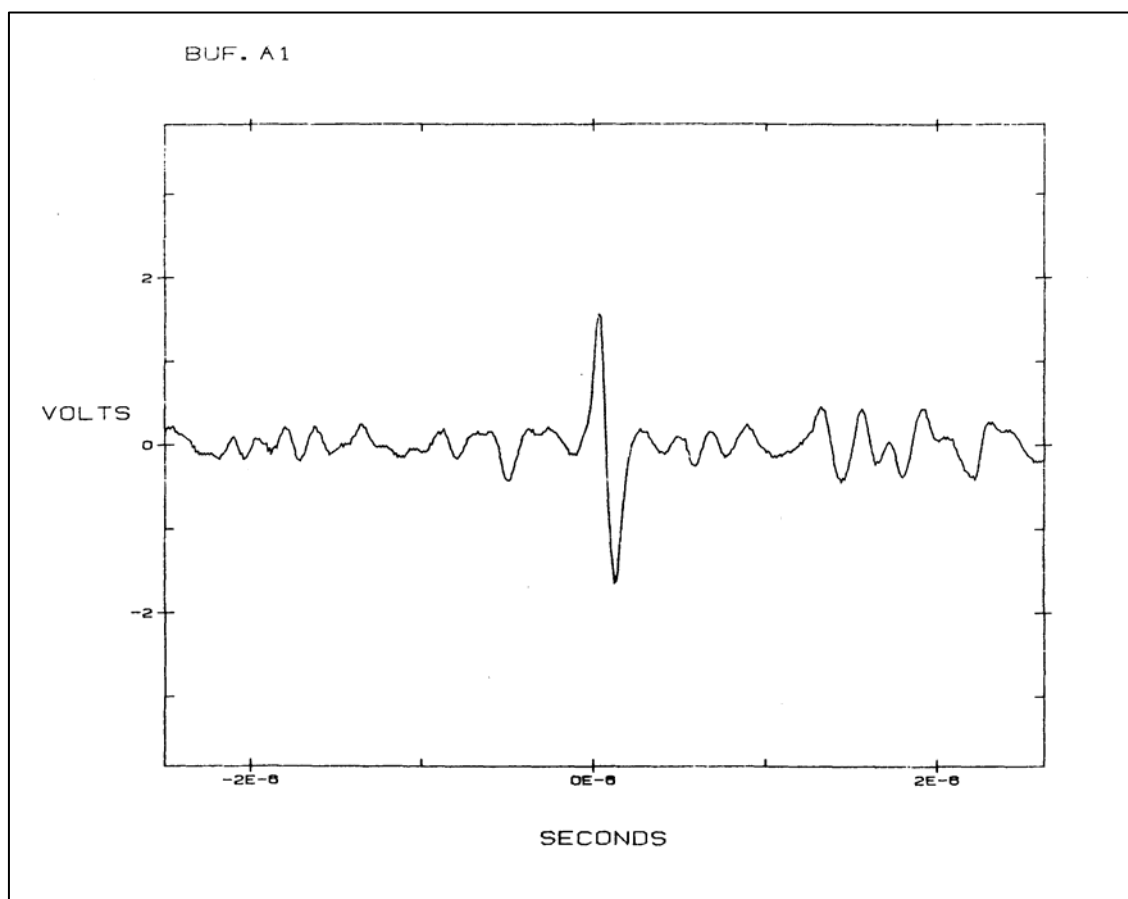

Figure 2-192. Doublet.

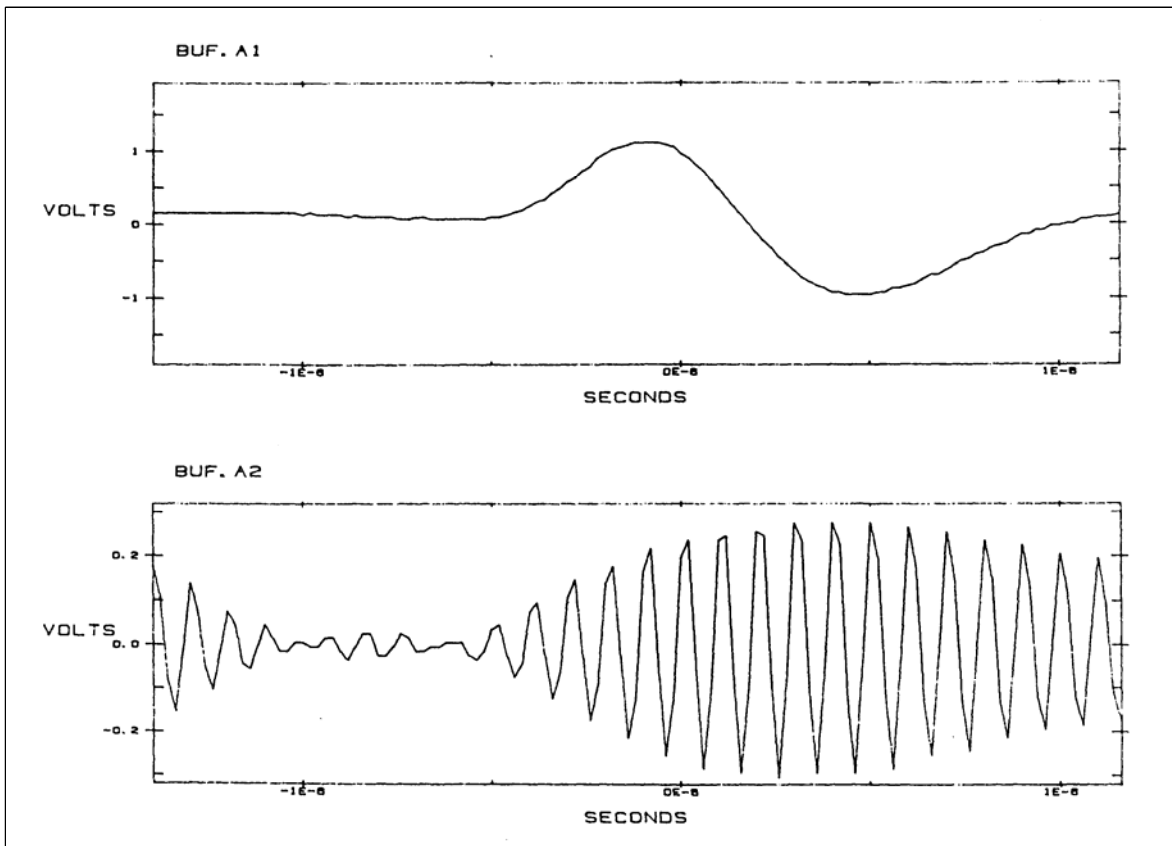

Figure 2-193. Doublet (upper trace) and IF signal.

2.13 Telemetry and GPS Compatibility

Global Positioning System (GPS) receivers are sensitive devices designed to receive low-level GPS signals. Many vehicles have GPS and telemetry antennas located in close physical proximity. Therefore, a small GPS signal and a large telemetry signal may both be present at the output of the GPS antenna. GPS quality problems can result if proper attention to good system engineering is not done (Reference [2nn](#)). This section will present measured data from real experiments and provide guidelines for preventing and solving GPS interference problems. For example, the “Investigation of Telemetry and GPS Compatibility,” presented at the International Telemetry Conference (2000), was conducted with the DSQ-50A off and with the telemetry transmitter set to various frequencies (see Reference [2nn](#)). A bandstop filter was then connected to the telemetry transmitter output and additional tests were performed. The bandstop filter was centered at 1575.42 MHz, the GPS L1 frequency.

The data presented will be the results of tests with a DSQ-50A telemetry transmitting system and a GPS L1 C/A receiving system. The center frequency of GPS L1 is 1575.42 MHz. Several test programs have reported degraded Global Positioning System (GPS) performance when L-band (1435-1535 MHz) telemetry is used while other test programs have had acceptable GPS performance with L-band telemetry. Most test programs seem to have minimal problems with S-band telemetry interfering with GPS performance if a bandpass or lowpass filter is used between the GPS antenna and low noise amplifier (LNA). This section will present measured data on GPS performance with L- and S-band telemetry and explain what must be done to minimize interference to GPS. Both GPS carrier-to-noise density power ratio (C/No) values and measured spectra from telemetry transmitters will be presented. System design guidelines for compatible operation will be discussed.

The DSQ-50A is a miss distance indicator system that uses either an L-band (1435-1535 MHz) or an S-band (2200-2290 MHz) telemetry link. Previous tests had shown that GPS L1 receiver performance was sometimes degraded when L-band telemetry was used but not when S-band telemetry was used. The purpose of this study was to first understand what was happening and then to solve the problem. A series of laboratory and rooftop tests were undertaken. The significant results of these tests will be presented in this section.

Tests with a DSQ-50A system and an Ashtech Corporation G12 GPS C/A code receiver were conducted on a rooftop at Point Mugu, CA. The antennas for the two systems were mounted on a BQM-74E nose section (the BQM-74E is an aerial target). The nominal output of the DSQ-50A's telemetry transmitter is 2 to 3 watts. The block diagram of the test setup is shown in Figure [2-194](#). The DSQ-50A telemetry transmitting antenna was about 24 inches away from the GPS receiving antenna. The DSQ-50A sensor antenna was about 5 inches away from the GPS receiving antenna. The sensor output was not connected to the antenna but rather was terminated in 50 ohms for this test. The purpose of the bandpass filter in front of the GPS LNA is to attenuate the telemetry signals to minimize interference to the GPS receiver and to prevent the LNA from saturating. The tests consisted of recording the information from the Ashtech G12 receiver for about 15 seconds and recording the spectrum of the signal at the input

to the GPS receiver (via directional coupler connected to spectrum analyzer). Spectrum analyzers typically have high noise figures, therefore one needs to make sure that the noise floor of the spectrum analyzer used is low enough so that the signals of interest can be measured. One may need to add an additional amplifier before the spectrum analyzer. Tests were conducted with the DSQ-50A off and with the telemetry transmitter set to various frequencies. A bandstop filter was then connected to the telemetry transmitter output and additional tests were performed. The bandstop filter was centered at 1575.42 MHz, the GPS L1 frequency.

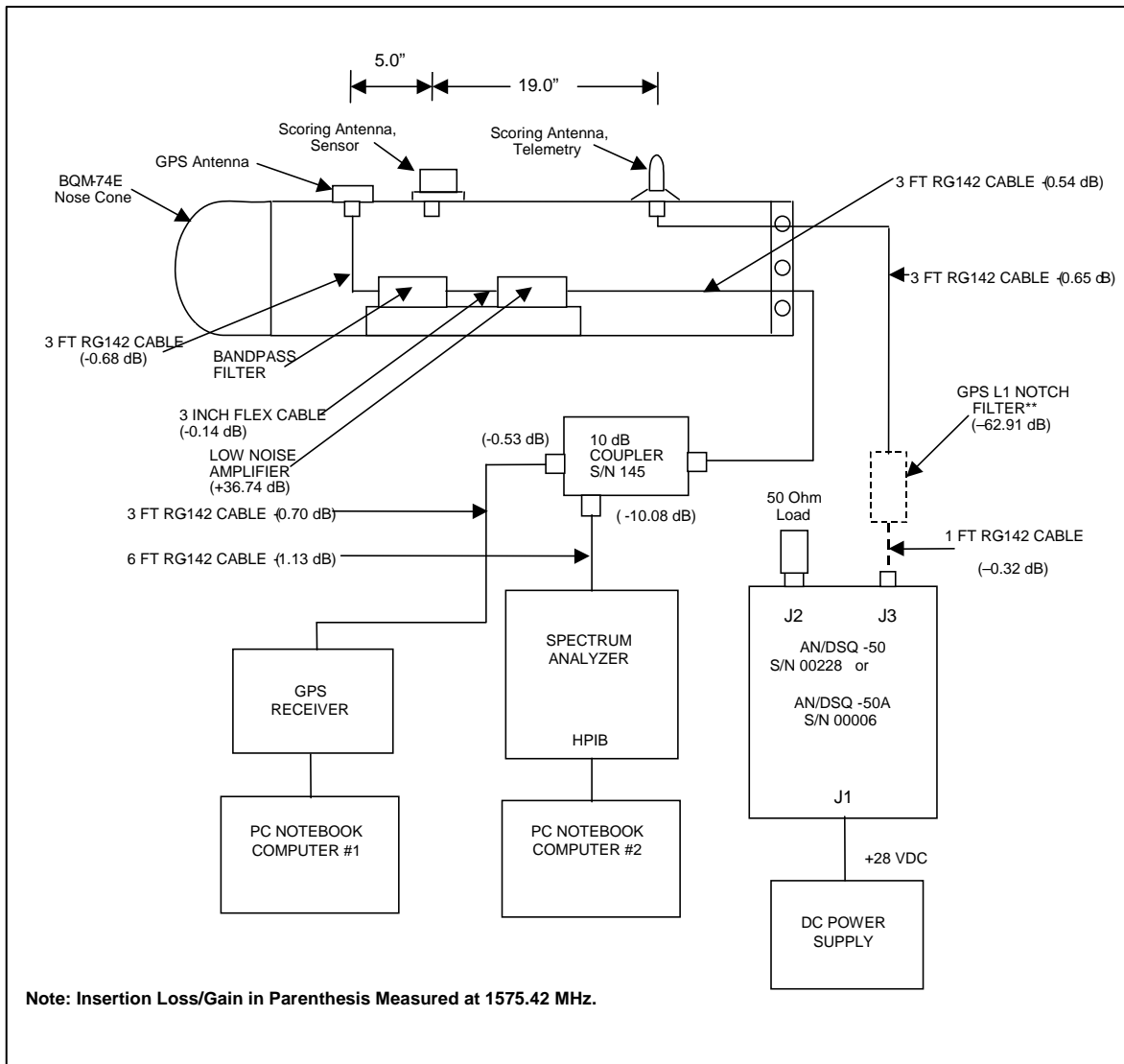

Figure 2-194. Test setup.

The first DSQ-50 telemetry frequency tested was 2204.5 MHz. The GPS C/No values were essentially the same whether the DSQ-50 was on or off. When the DSQ-50A was set to 1525.5 and 1482.5 MHz no satellites were acquired while only one satellite at 27.7 dB-Hz C/No was acquired with the DSQ-50A set to 1506.5 MHz. Seven satellites were acquired with the DSQ-50A set to 1435.5 MHz with an average C/No degradation of 2.7 dB. The spectrum analyzer plots are shown in Figure 2-195. The average noise levels in a 2 MHz span around 1575.4 MHz with respect to DSQ-50A off were: -0.4 dB with 2204.5, +2.4 dB with 1435.5, +25.4 dB with 1482.5, +14.6 dB with 1506.5, and +16.1 dB with 1525.5 (the spectrum analyzer noise floor was taken into account in calculating these values). The increase in average noise level at 1575.4 MHz is about the same as the decrease in satellite C/No. Therefore, it is very likely that the main problem is excess energy at frequencies near 1575.4 MHz. The high noise levels with 1482.5 MHz are caused by a discrete spurious signal with a power level of about -50 dBm. The source of the discrete signal is the divide-by-16 circuitry in the transmitter ($1482.5 + 1482.5/16 = 1575.2$ MHz).

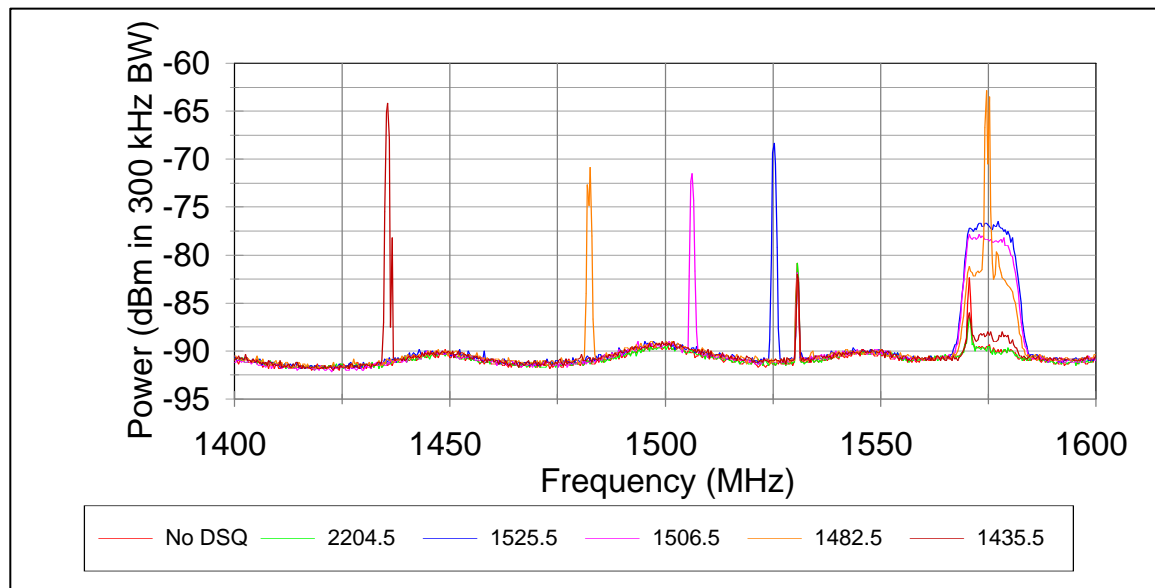

Figure 2-195. Spectrum analyzer plots at GPS LNA output.

Measurements of the telemetry transmitter in a laboratory setting were performed to characterize the excess noise in a more controlled environment. The test setup is shown in Figure 2-196. A 10-dB attenuator was used on the telemetry transmitter output to minimize the probability of damaging or saturating any device in the signal path. The measured excess power levels with the DSQ-50A turned on are shown in Figure 2-197. Note that the only signals above the noise floor are the transmitter frequencies and the frequency band around 1575.4 MHz in the bandpass filter's passband. The bandpass filter does a good job of attenuating the main telemetry signal but does not attenuate the signal at 1575.4 MHz. The power per Hertz at 1575.4 MHz at the output of this transmitter is plotted in Figure 2-198 (points connected by line). The noise power at 1575.4 MHz decreases as the transmitter frequency is decreased. The other points plotted in Figure 2-198 were taken with four fixed frequency transmitters from three manufacturers.

The noise power density for the GPS system with the DSQ-50A turned off was about -172 dBm/Hz. The noise powers of this transmitter are 35 to 45 dB above the noise floor of a device with a noise power density of -172 dBm/Hz (see Figure 2-198). The antenna isolation for the rooftop test antenna configuration was about 30 dB, which is not enough to eliminate the effects of the excess transmitter noise.

Two potential causes of the excess noise levels are phase noise and amplifier thermal noise (noise floor). Data from the transmitter manufacturer shows the measured phase noise 1 MHz away from the carrier is typically about -128 dBc/Hz and the power is decreasing by 6 dB/octave. Extrapolating this value to a frequency 50 MHz from the carrier one gets $(-28 - 20 \log(50) = -162$ dBc/Hz). The transmitter output power (0 dBc) was about $+34$ dBm, therefore, the phase noise would be -128 dBm/Hz which is very close to the values shown in Figure 2-198 (-127 dBm/Hz for 1525.5 MHz and -119 to -132 dBm/Hz for 1527.5 MHz). The extrapolated phase noise for a frequency 140 MHz from the carrier would be -137 dBm/Hz, which is the same as the measured noise value at 1435.5 MHz. We do not know the amplifier characteristics but it appears that phase noise is the most likely source of excess noise at 1575.4 MHz for the small number of transmitters tested so far. Measurements of other, higher-output power transmitters have shown noise levels as high as -101 dBm/Hz. One potential approach to decreasing telemetry transmitter noise levels at GPS L1 is to use a VCO with lower phase noise in the frequency range of 40 to 150 MHz from the telemetry transmitter center frequency.

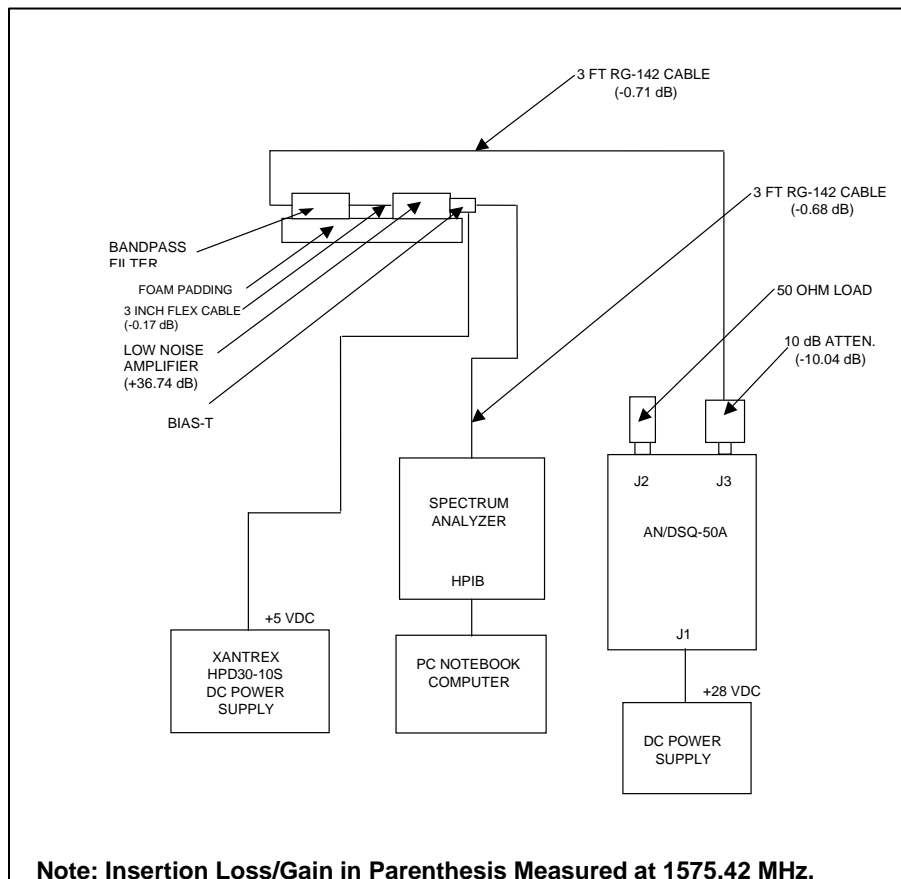

Figure 2-196. Laboratory test setup.

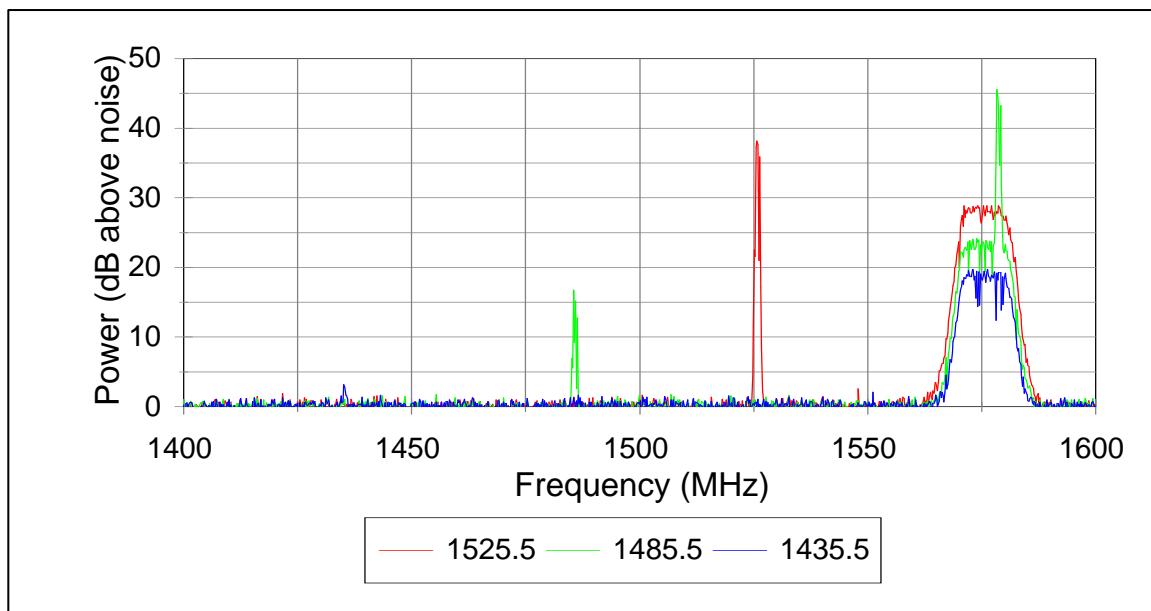

Figure 2-197. Excess power levels with transmitter on (10 dB attenuation).

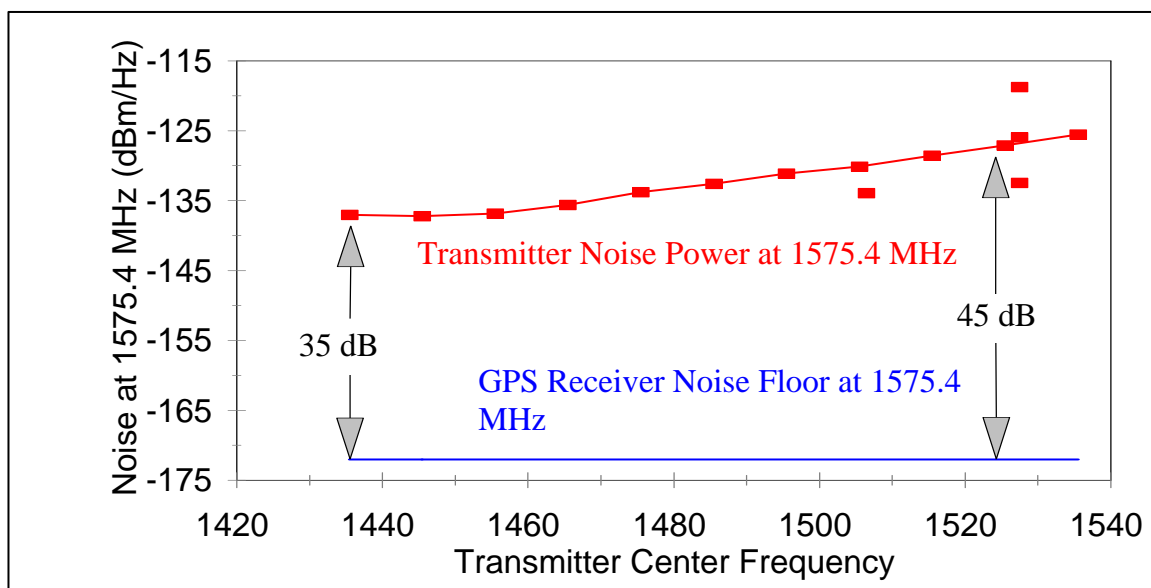

Figure 2-198. Transmission noise power at 1575.4 MHz.

Figure [2-199](#) shows the spectrum of a DSQ-50 telemetry transmitter that interfered with the GPS system on a target. The noise power at 1575.4 MHz is similar to other transmitters but note the large spur at 1570 MHz. This transmitter has spurs about every 21 MHz. The power in the spur at 1570 MHz was about -45 dBm at the transmitter output, which is 20 dB better than required by IRIG Standard 106, [Telemetry Standards](#). However, the power in this spur is high enough to cause problems for the GPS receiver. The International Civil Aviation Organization (ICAO) has standardized an interference threshold mask for sinusoidal signals. The ICAO mask level for frequencies near 1575 MHz is -120.5 dBm (see reference [3-uu](#)).

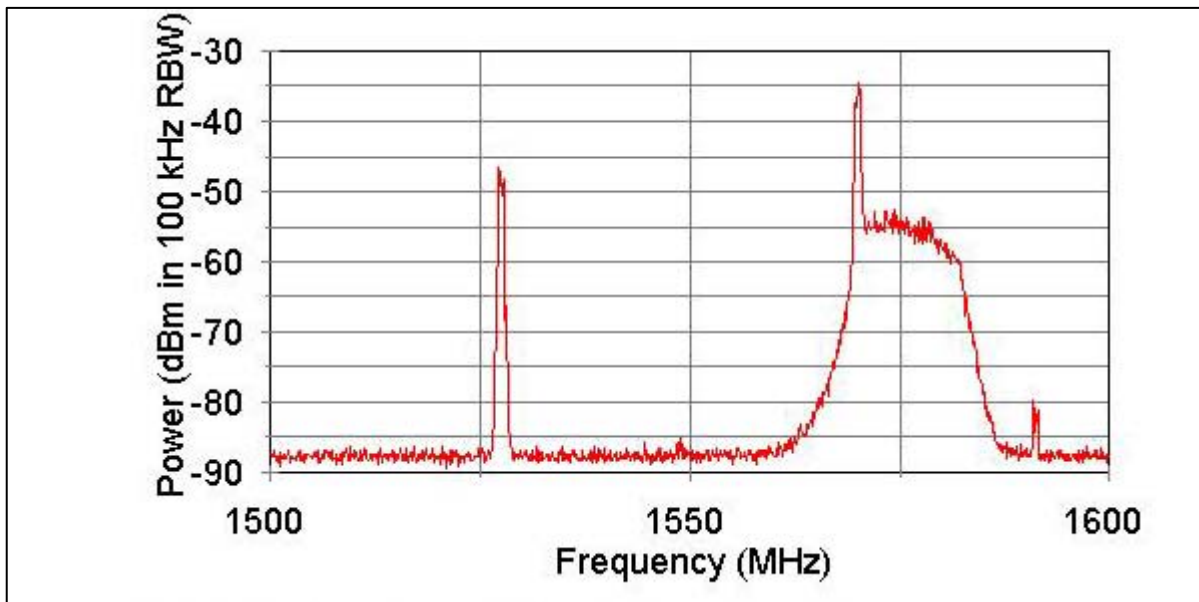

Figure 2-199. DSQ- 50 telemetry transmitter + BPF + LNA.

Other options to solve this problem include increasing antenna isolation, adding a bandpass filter centered on the telemetry band, or adding a bandstop filter centered at 1575.42 MHz at the telemetry transmitter output. A bandstop filter with nominal bandwidth of 10 MHz centered at GPS L1 was located and the GPS tests were repeated. The results for the six satellites with elevation angles greater than 10 degrees that were common to all of these tests are plotted in Figure [2-200](#). The satellite acquisition speed and number of satellites were now the same whether the DSQ-50A was on or off. The average of all satellite C/No values (shown in parentheses in the legend portion of Figure 2-200) with the DSQ-50A on was 0.1 to 0.7 dB lower than the beginning C/No values with DSQ-50A off and 0.4 dB higher to 0.2 dB lower than the ending C/No values with DSQ-50A off. These differences are within measurement error.

Additional tests were conducted with a radio frequency signal generator summed with the GPS signal and connected to the LNA input. At a frequency of 1525.5 MHz, a signal level at the LNA input of about -53 dBm resulted in a GPS C/No degradation of about 3 dB. The degradation was somewhat less for lower generator frequencies at the same power level.

Many GPS LNAs are quite broad band; for example, one LNA had a measured gain of 31 dB at 1575.4 MHz and 1485.5 MHz and a gain of 25 dB at 2250.5 MHz. Assuming a 2-watt transmitter at 2250.5 MHz and 30 dB of isolation between the telemetry and GPS antennas, the signal at the LNA input without a filter would be +3 dBm. After the 25-dB gain LNA, the signal would be +28 dBm; however, the LNA output saturates at about +13 dBm so the output would be saturated at +13 dBm. The saturated LNA would cause the GPS signals to be suppressed and degrade the GPS data quality. One solution is to put a bandpass filter between the GPS antenna and the LNA. If the filter has 40 dB of attenuation at 2250.5 MHz, the telemetry signal would be -37 dBm at the LNA input and therefore -12 dBm at the output and well below the saturation point of most GPS LNAs.

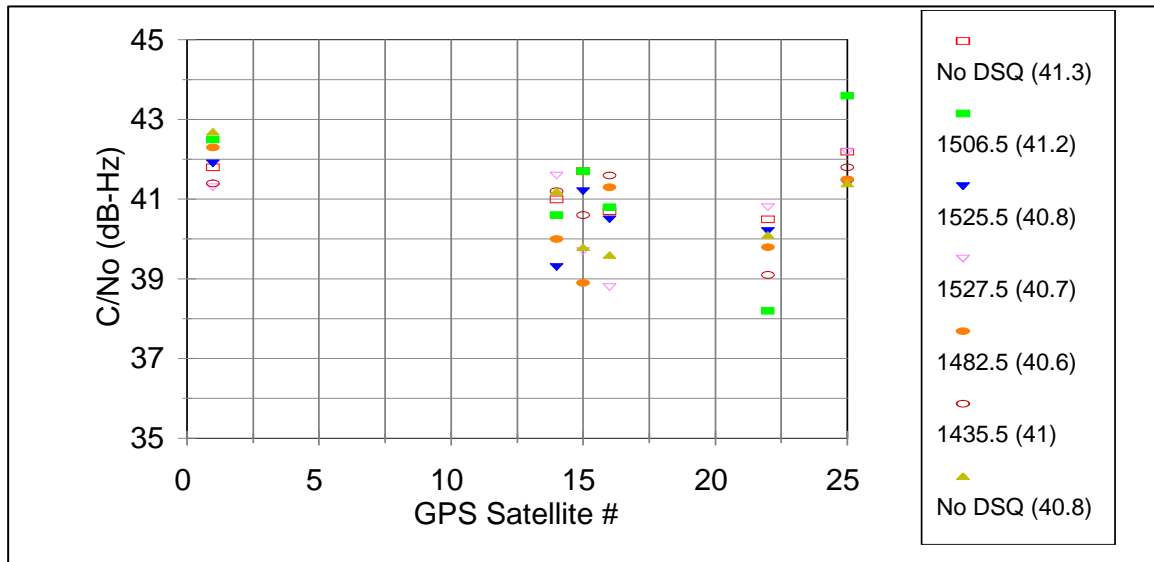

Figure 2-200. GPS satellite C/N values with DSQ-50A and bandstop filter.

A conceptual block diagram of a telemetry plus GPS system designed to minimize interference is shown in Figure 2-201. Note the bandpass filter before the GPS LNA to attenuate interfering signals outside of the GPS bands and the bandstop (or bandpass) filter to attenuate signals emanating from the telemetry transmitter near the GPS L1 frequency. Filters may sometimes also be required at GPS L2 but preliminary tests have shown lower noise levels at GPS L2 because it is much further away from the transmitter center frequency).

The tests described in this section point out that significant isolation is needed between the output of an L-band telemetry transmitter and the GPS LNA. Typically, at least 90 dB of attenuation (100 dB preferred) of the main telemetry signal and at least 40 to 50 dB of attenuation of the telemetry transmitter's noise at 1575.42 MHz is required. Telemetry transmitters that have spurious outputs close to 1575.4 MHz may require more than 50 dB of isolation at 1575.4 MHz. The typical specification for spurious signals at the output of a telemetry transmitter is -25 dBm, however, levels much lower than -25 dBm can cause problems if the frequency is close to the GPS frequencies. Problems are less likely to exist when S-band telemetry transmitters are used but problems can occur if the transmitter has spurs close to the GPS frequencies or if the telemetry transmitter saturates the GPS LNA. Many typical antenna configurations do not provide sufficient isolation. Therefore, both a good

bandpass filter before the GPS LNA and possibly a bandstop or bandpass filter at the L-band telemetry transmitter output will be required for good GPS performance. Telemetry transmitters with lower output levels near GPS frequencies would reduce the probability of needing the bandstop filter. The tests discussed in this section demonstrate that L-band telemetry and GPS can operate compatibly in near proximity if the recommended design is used and that problems are likely if a good design approach is not used.

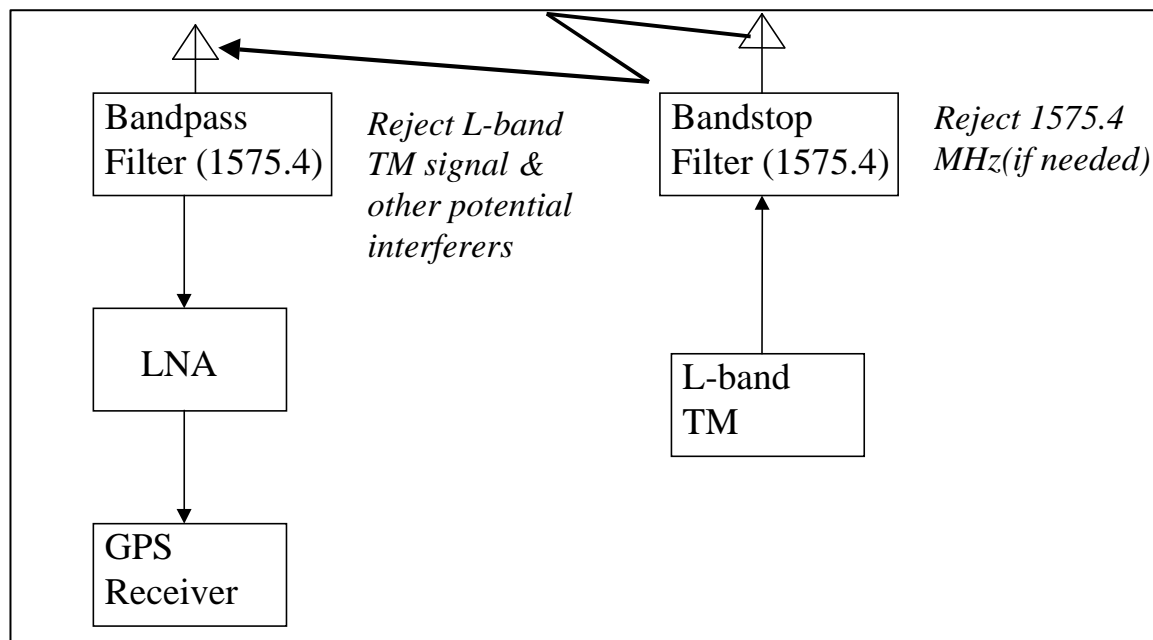

Figure 2-201. Block diagram of L-band telemetry and GPS systems designed to minimize interference.

2.14 Telemetry Signal Spacing

Telemetry data rates are increasing and the amount of available telemetry spectrum has been decreasing. The combination of these two facts is driving efforts to increase the telemetry channel packing density. Methods to increase channel packing density include more spectrally efficient modulation methods (including FQPSK, SOQPSK, and ARTM CPM) and the use of “better” receiver filters. A test program was initiated to measure the effects of carrier-to-interference ratio (C/I) and channel spacing on BEP at various E_b/N_0 values. The test setup is shown in Figure 2-202. The test setup shows three radio frequency (RF) sources however only two were used for most of the tests included in this section. The data sources were independent, pseudo-random signals of length $2^{15}-1$ or $2^{11}-1$. The non-return-to-zero-level (NRZ-L) CPFSK, ARTM CPM, SOQPSK and FQPSK signals were generated with laboratory test equipment and amplified with a Class C non-linear amplifier. The RF signals were applied to a FastBit 2000A test set that controlled E_b/N_0 and C/I. The shaded items in Figure 2-202 are part of the FastBit 2000A. The FastBit 2000A keeps the signal power fixed and varies the interference and noise power levels. The composite signal was connected to a telemetry receiver. The receiver’s intermediate frequency (IF) signal was connected to a RF Networks model 2120 demodulator or a Nova Engineering multi-mode trellis demodulator model MMD22 when SOQPSK-TG or

FQPSK-B (or -JR) was the desired signal and to a Nova Engineering model MMD22 when ARTM CPM was the desired signal. When CPFSK was the desired signal, either the receiver's internal demodulator and bit synchronizer or the Nova model MMD22 were used.

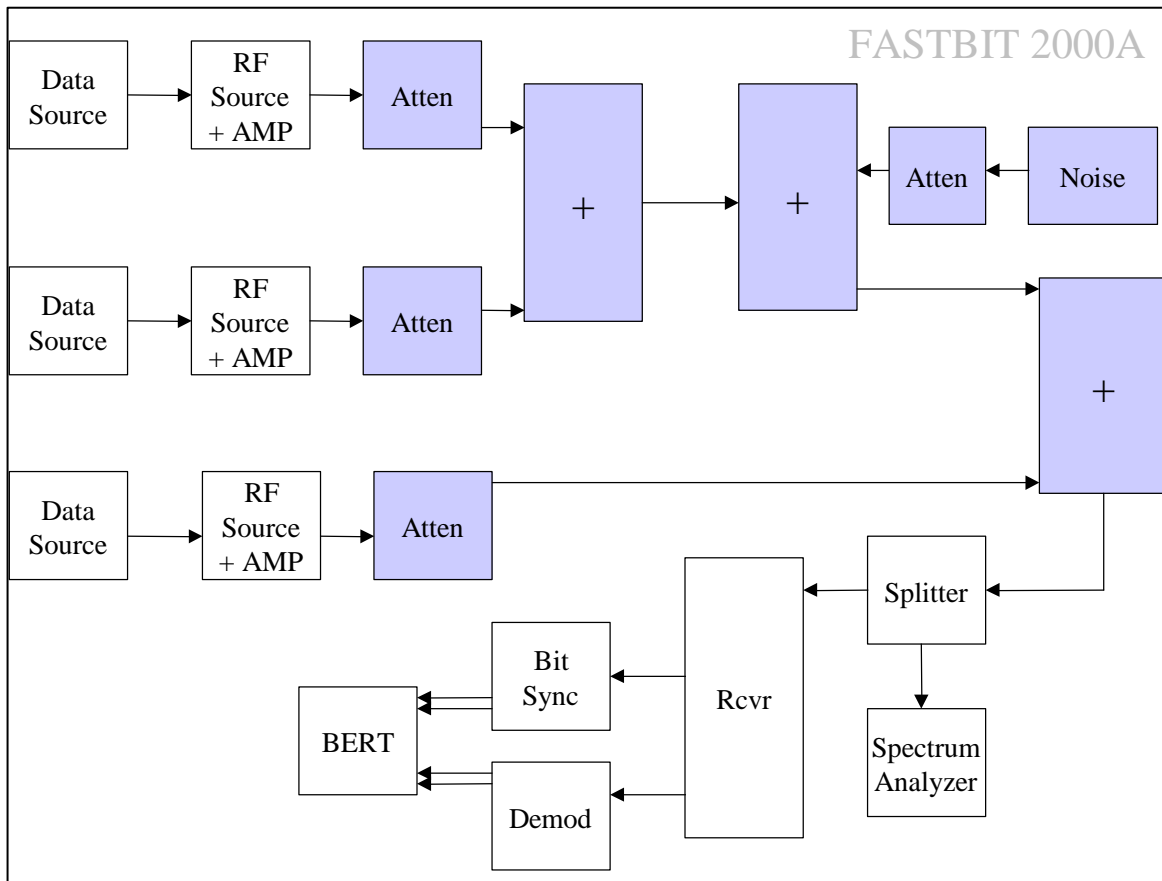

Figure 2-202. Test setup.

Sample spectra of the test signals are shown in Figure 2-203. The CPFSK signals were premodulation filtered with a 6-pole linear phase filter with a bandwidth of 0.7 times the bit rate, had a peak deviation of 0.35 times the bit rate, and were generated with the appropriate signals from a Rohde&Schwartz AMIQ driving the I/Q inputs of the RF generator. CPM and SOQPSK-TG signals were generated using a Rohde&Schwartz AMIQ driving the I/Q inputs of the RF generator. Mark Geoghegan of Nova Engineering supplied the above AMIQ files. FQPSK-JR (and -B) base band signals were generated using either a RF Networks base band processor board assembled into a chassis by Edwards AFB personnel or AMIQ files supplied by Robert Jefferis, Tybrin Corp., Edwards AFB. The RF sources were Agilent model E4433As. These RF signal generators have both frequency modulation (FM) and quadrature (I/Q) modulation capability. The FQPSK tests were conducted with I/Q modulator imbalances that cause spectral expansion typical of the near-worst case measured FQPSK transmitters (note where FQPSK-JR spectrum is wider than SOQPSK-TG below -45 dBc in Figure 2-203; this spectral regrowth is caused by a combination of I/Q modulator errors combined with the effects of the non-linear amplifier).

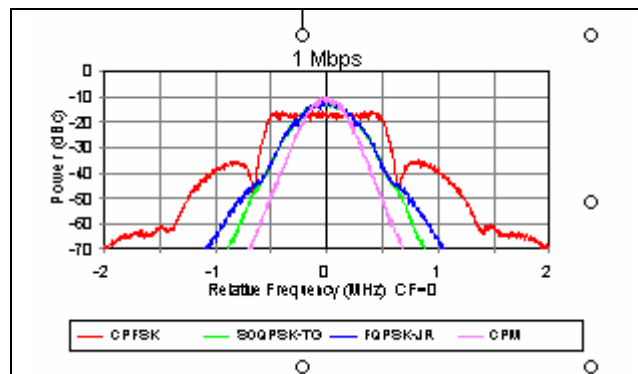

Figure 2-203. Signal spectra.

2.14.1 Adjacent Channel Interference. BEP versus E_b/N_0 data were measured with various frequency spacings for a variety of desired and interfering bit rates, desired and interfering modulation methods, and various receivers and demodulators. The C/I was 20 dB unless otherwise stated.

Figure 2-204 presents BEP versus E_b/N_0 data with 5 Mb/s NRZ-L PCM/FM as both the desired signal and interfering signal with several values of spacing between the signals (the frequency spacing in MHz is shown in the legend). It was found that the degradation increased fairly slowly as the spacing was decreased, and that when the degradation was greater than about 0.5 dB, the degradation started to increase rapidly. Note in Figure 2-204 that the first few curves are close to the no-interference curve (i.e. “No I”) but the last two curves (8 and 7.5) start to move up and to the right rapidly). What is happening is that the interfering power getting to the bit detector is starting to be a significant fraction of the noise power. The curves are similar for all of the combinations of modulation methods. The difference in E_b/N_0 values for a given BEP (a BEP of about 10^{-5} was used for this study) was estimated and used as the criteria for acceptable spacing.

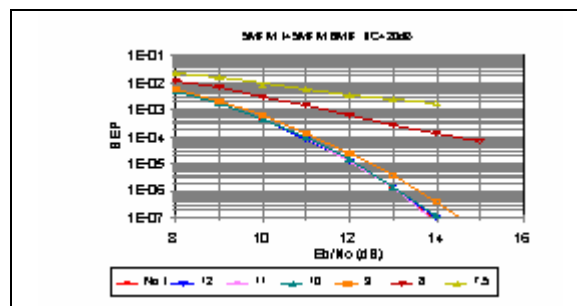

Figure 2-204. ACI effects with 5 MBPS PCM/FM.

Figures 2-205, 2-206 and 2-207 show measured BEPs for a fixed E_b/N_0 (the E_b/N_0 was fixed about 0.5 dB higher than the E_b/N_0 which gave a BEP of about 10^{-5}) for 5 Mb/s PCM/FM, SOQPSK-TG, and ARTM CPM with several interfering bit rates (interfering bit rate and modulation method are shown in the legend (5MDFM is 5 Mb/s PCM/FM)) and several frequency spacings. The solid horizontal lines show the BEP at 0.5 dB degradation.

Figure 2-208 and Figure 2-209 show the results of similar tests for 8 Mb/s SOQPSK-TG with intermediate frequency (IF) bandwidths of 8 and 16 MHz respectively. Note in Figure 2-209 the curves for the 3 lowest rate interferers are all bunched together. The problem illustrated here is that the dynamic range of the demodulator is being exceeded because the receiver IF filter is not attenuating the interfering signal.

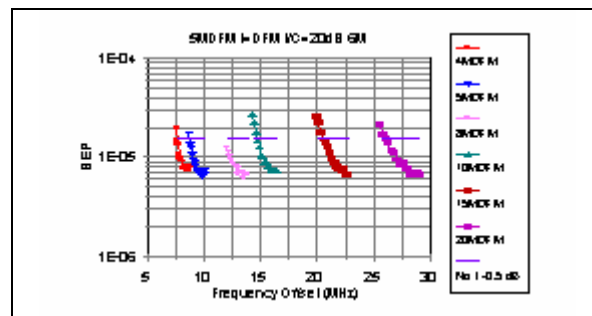

Figure 2-205. 5 MBPS PCM/FM with various interferers.

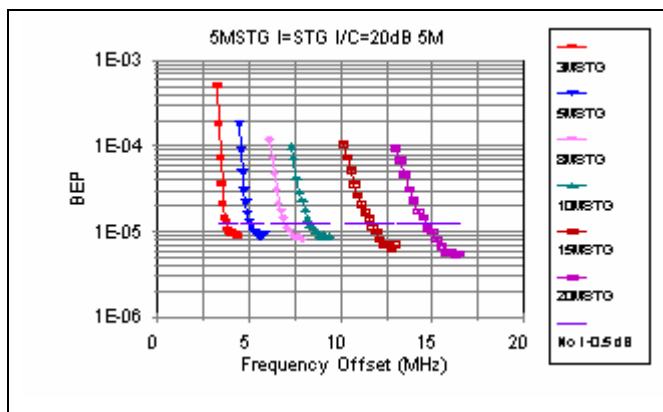

Figure 2-206. 5 Mbps SOQPSK-TG.

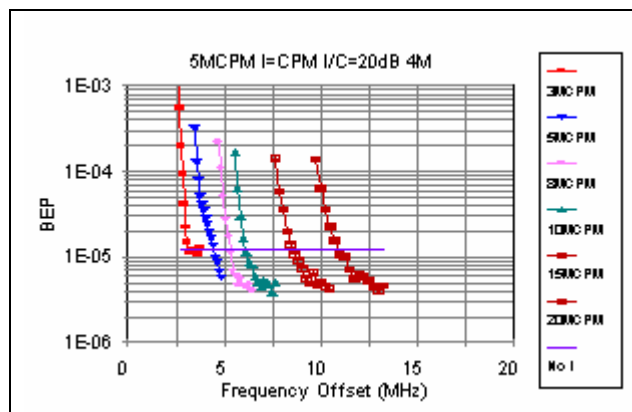

Figure 2-207. 5 Mbps ARTM CPM.

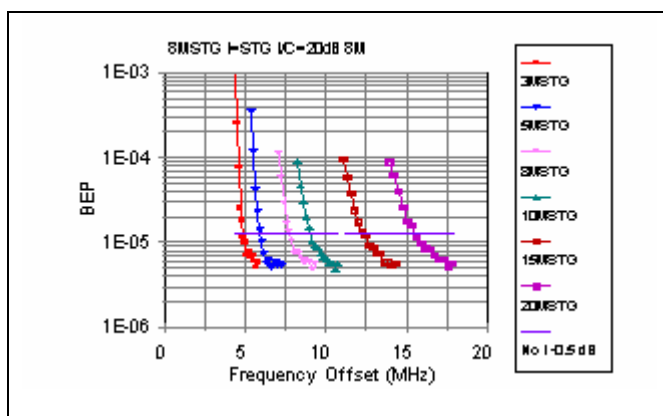

Figure 2-208. 8 Mbps SOQPSK-TG with 8 MHz IF BW.

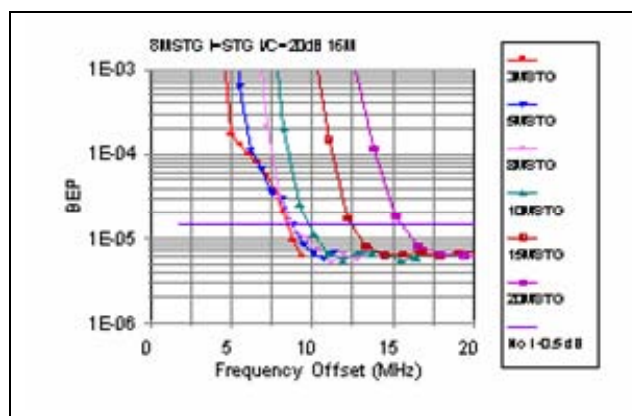

Figure 2-209. 8 Mbps SOQPSK-TG with 16 MHz IF BW.

Figure 2-210 and Figure 2-211 show the results of tests where the C/I ratio was varied from -8 dB to -26 dB. These figures show that with a C/I ratio of -8 or -11 dB the differences between the performance with the two IF filters is small whereas with C/I ratios of -20 , -23 , and -26 dB the differences are fairly large. One of the main functions of the IF filter is to control the amount of interference power, which minimizes the instantaneous dynamic range at the input to the demodulator.

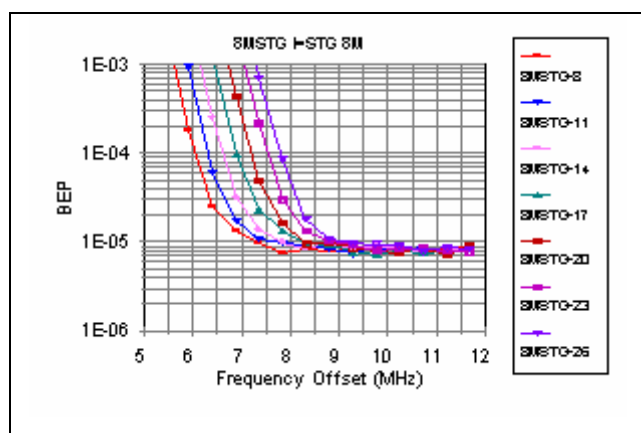

Figure 2-210. 8 Mbps SOQPSK-TG with 8 MHz IF BW and various C/I ratios.

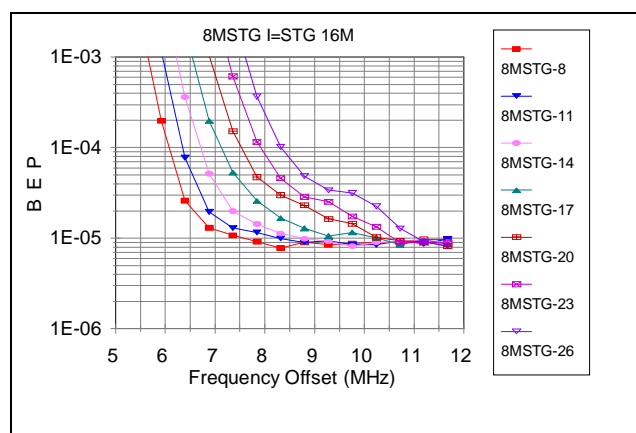

Figure 2-211. 8 Mbps SOQPSK-TG with 16 MHz IF BW and various C/I ratios.

Figure 2-212 and Figure 2-213 show the results with the desired signal being 1 and 20 Mb/s PCM/FM and the interfering signal being 15 Mb/s PCM/FM. The receiver in this case had digitally generated IF filters. The minimum required separation is about 18 MHz in figure 11 and 31 MHz in Figure 2-213. Since the interfering signal is the same, the difference is a function of the desired signal and the receiver/demodulator. For this case, the minimum required frequency spacing can be approximated by $0.7 \cdot S + 1.2 \cdot I$ where S is the bit rate of the desired signal and I is the bit rate of the interferer.

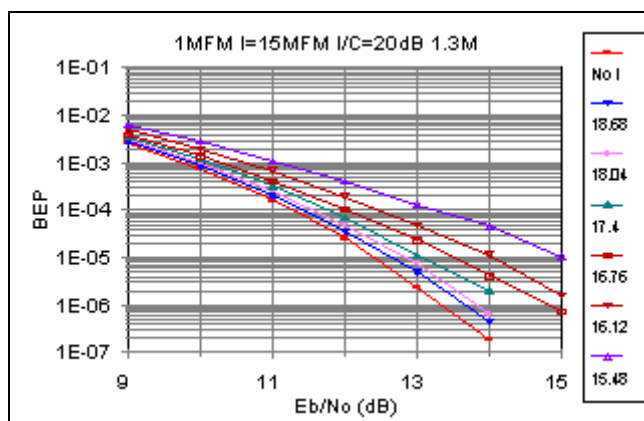

Figure 2-212. 1 MBPS PCM/FM with $I = 15$ Mbps PCM/FM.

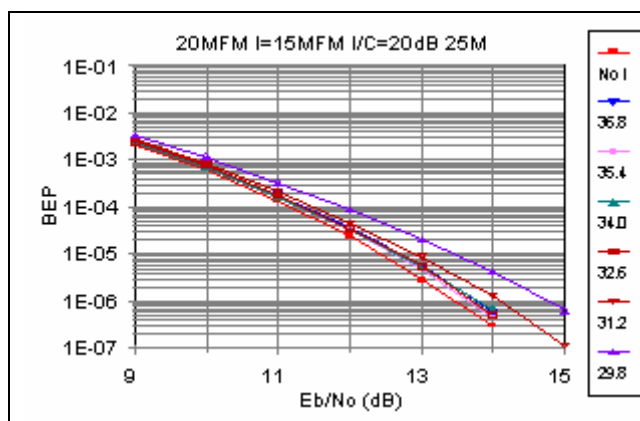

Figure 2-213. 20 MBPS PCM/FM with $I = 15$ Mbps PCM/FM.

2.14.2 Minimum Required Frequency Separation. Figure 2-214 shows the measured spacings for 0.5 dB degradation with 5 Mb/s SOQPSK-TG as the desired signal and various interfering signals. Note that the points for each interferer essentially form a straight line with the slope being different for each type of interference. This discovery greatly simplifies the expressions for required frequency spacing. One exception to this “rule” occurs when one of the adjacent signals is a high bit rate and the other is a low bit rate. In that case, the required minimum spacing is a factor of the -6 dB IF bandwidth for PCM/FM with lumped constant (LC) receiver filters. This case is illustrated in Figure 2-215. Note the flattening out of the 5M-LC curve with interfering bit rates below 5 Mb/s.

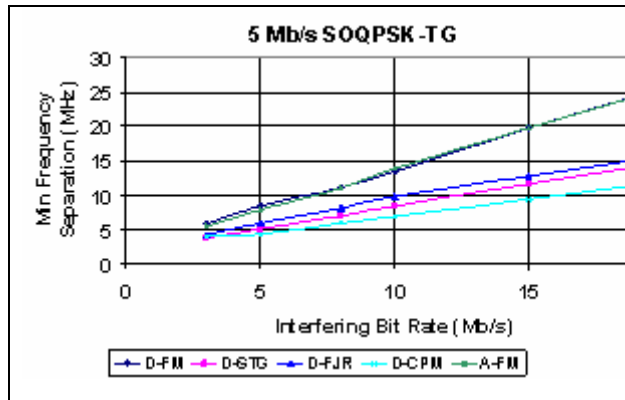

Figure 2-214. Minimum frequency separation.

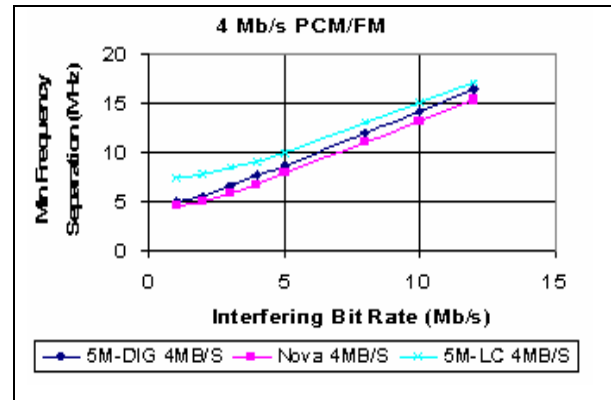

Figure 2-215. Minimum frequency separation for 4 MB/S PCM/FM.

The minimum required frequency separations can be calculated using the formula

$$DF = A*S + B*I \quad (2-36)$$

where

DF is the minimum required frequency separation in MHz

S is the bit rate of the desired signal in Mb/s

I is the bit rate of the interfering signal in Mb/s

A is determined by the desired signal type and receiving equipment (see Table 2-12 below)

B is determined by the interfering signal type (see Table 2-12 below)

Note: The interfering signal is assumed no more than 20 dB stronger than the desired signal.

TABLE 2-12. COEFFICIENTS FOR FREQUENCY SEPARATION CALCULATION

| Modulation Type | A | B |
|---|---|-------------|
| NRZ PCM/FM | 1.0* for receivers with RLC final IF filters 0.7 for receivers with SAW or digital IF filters 0.5 with Nova multi-symbol detectors (or equivalent devices) | 1.2 |
| FQPSK-B, FQPSK-JR, SOQPSK-TG | 0.45 | 0.65 |
| ARTM CPM | 0.35 | 0.5 |
| <p>* The minimum frequency separation for typical receivers with RLC final IF filters and NRZ-L PCM/FM signals is the larger of 1.5 times the actual IF –3 dB bandwidth and the value calculated using the equation above.</p> <p>**The value of B for FQPSK signals is a function of the modulator errors and is equal to 0.65 with no significant modulator errors.</p> | | |

The minimum spacing needs to be calculated for signal 1 as the desired signal and signal 2 as the interferer and vice versa. It is interesting to note that the values for B match the normalized –50 dBc points for the four modulation methods shown in Figure 2-203 quite closely. It is not surprising that the required frequency spacing from the interferer is directly related to the power spectrum of the interfering signal. The values for A are a function of the effective detection filter bandwidths and the co-channel interference resistance of the modulation method and detector. The values for A and B are slightly conservative for most cases and assume that the receiver being used does not have spurious responses that cause additional interference.

The main assumptions are as follows:

- a. The NRZ PCM/FM signals are assumed to be premodulation filtered with a multipole filter with -3 dB point of 0.7 times the bit rate and the peak deviation is assumed to be approximately 0.35 times the bit rate.
- b. The receiver IF filter is assumed to be no wider than 1.5 times the bit rate and provides at least 6 dB of attenuation of the interfering signal.
- c. The interfering signal is assumed to be no more than 20 dB stronger than the desired signal.
- d. The receiver is assumed to be operating in linear mode; no significant intermodulation products or spurious responses are present.

Examples immediately follow:

5 Mb/s PCM/FM and 6 Mb/s PCM/FM using Microdyne 1200MRC receivers with 6 MHz IF bandwidths (these receivers have RLC IF filters)

$1.0*5 + 1.2*6 = 12.2$ MHz $1.0*6 + 1.2*5 = 12$ MHz $1.5*6 = 9.0$ MHz; the largest value is 12.2 MHz and the frequencies are assigned in 1 MHz steps so the minimum spacing is 13 MHz

5 Mb/s PCM/FM and 6 Mb/s PCM/FM using Microdyne 1200MRC receivers with 10 MHz IF bandwidths (these receivers have RLC IF filters)

$1.0*5 + 1.2*6 = 12.2$ MHz $1.0*6 + 1.2*5 = 12$ MHz $1.5*10 = 15.0$ MHz; the largest value is 15.0 MHz and the frequencies are assigned in 1 MHz steps so the minimum spacing is 15 MHz

5 Mb/s PCM/FM and 6 Mb/s PCM/FM using Microdyne 1200MRC receivers with 6 MHz IF bandwidths and Nova demodulators

$0.5*5 + 1.2*6 = 9.7$ MHz $0.5*6 + 1.2*5 = 9$ MHz; the largest value is 9.7 MHz and the frequencies are assigned in 1 MHz steps so the minimum spacing is 10 MHz

5 Mb/s PCM/FM and 6 Mb/s FQPSK-B using Microdyne 1200MRC receivers with 6 MHz IF bandwidths (these receivers have RLC IF filters)

$1.0*5 + 0.7*6 = 9.2$ MHz $0.45*6 + 1.2*5 = 8.7$ MHz $1.5*6 = 9.0$ MHz; the largest value is 9.2 MHz and the frequencies are assigned in 1 MHz steps so the minimum spacing is 10 MHz

5 Mb/s PCM/FM and 6 Mb/s FQPSK-B using Microdyne RCB2000 receivers with 6 MHz IF bandwidths (these receivers have SAW/digital IF filters)

$0.7*5 + 0.7*6 = 7.7$ MHz $0.45*6 + 1.2*5 = 8.7$ MHz; the largest value is 8.7 MHz and the frequencies are assigned in 1 MHz steps so the minimum spacing is 9 MHz

5 Mb/s SOQPSK-TG and 6 Mb/s SOQPSK-TG using Microdyne 1200MRC receivers with 6 MHz IF bandwidths (these receivers have RLC IF filters)

$0.45*5 + 0.65*6 = 6.15$ MHz $0.45*6 + 0.65*5 = 5.95$ MHz; the largest value is 6.15 MHz so the minimum spacing is 7 MHz

Figure 2-216 through Figure 2-19 show examples of various modulation methods with frequency spacing determined using the coefficients from Table 2-11. The bit rate was 10 Mb/s for all of these figures.

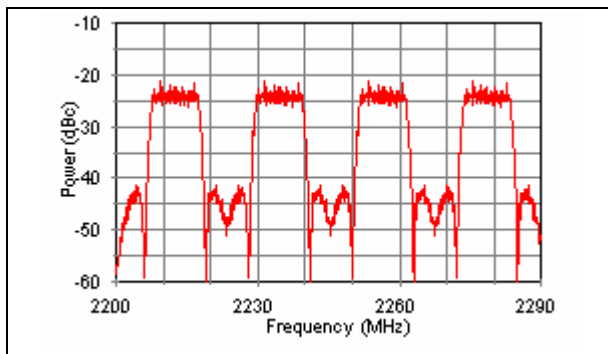

Figure 2-216. 10 Mb/s NRZ PCM/FM with receiver with typical RLC filters assumed.

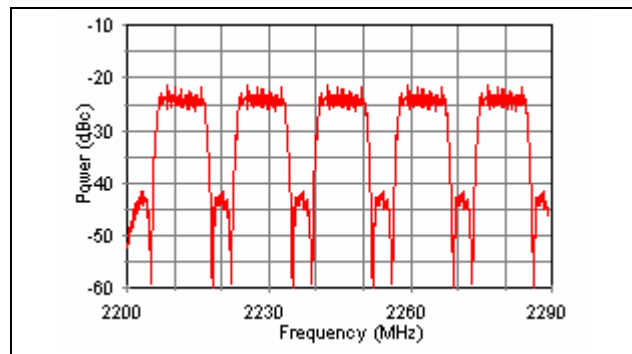

Figure 2-217. 10 Mb/s NRZ PCM/FM with multi-symbol detector assumed.

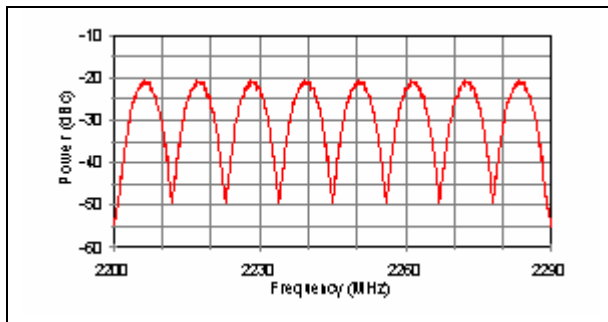

Figure 2-218. 10 Mb/s SOQPSK-TG or FQPSK-JR.

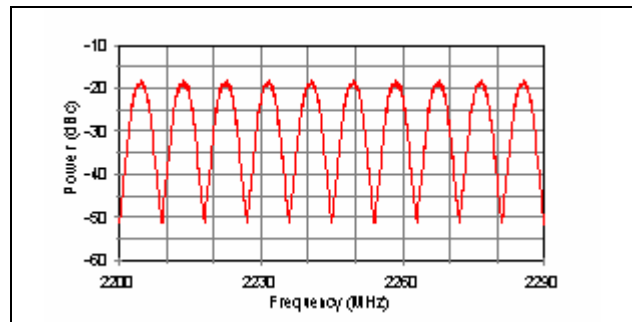

Figure 2-219. 10 Mb/s ARTM cpm.

2.14.3 Co-channel Interference. Figure 2-220 shows the co-channel interference performance of the various modulation methods with both desired signal and interferer set to 5 Mb/s (the first group of letters indicates the desired signal and the second the interferer, that is, FM-JR indicates the desired signal is PCM/FM and the interfering signal is FQPSK-JR). Figure 2-220 shows that PCM/FM is the most resistant to co-channel interference and ARTM CPM is the least resistant.

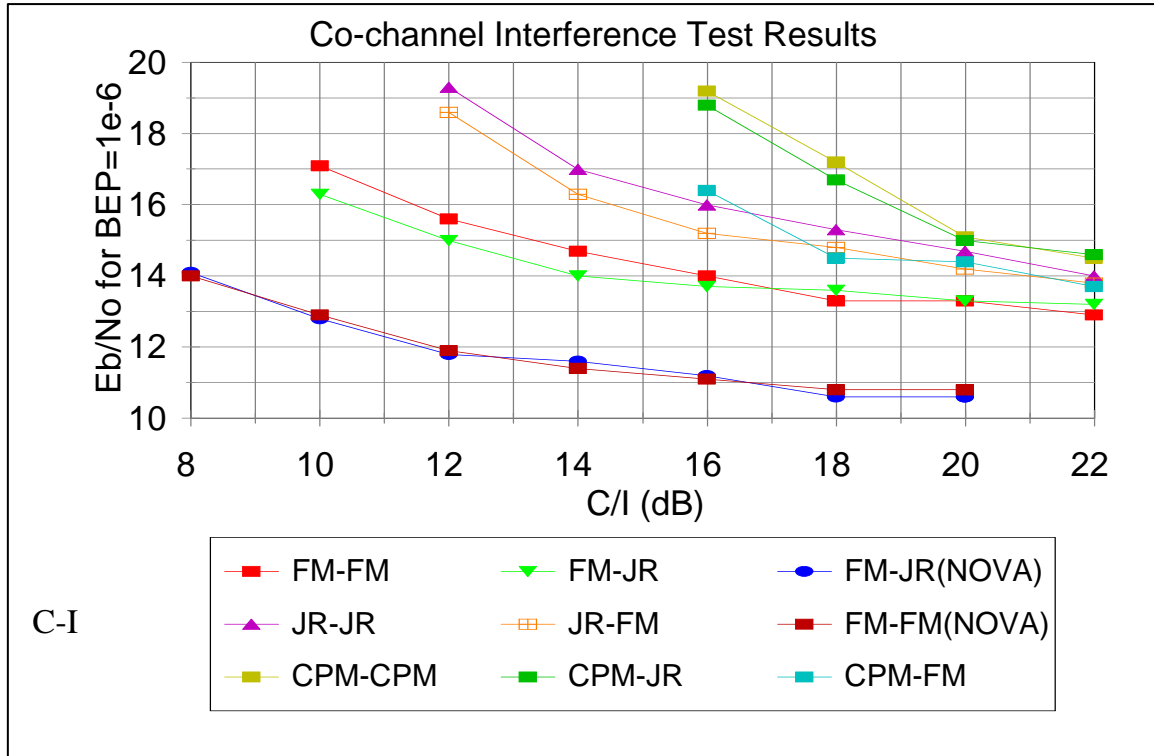

Figure 2-220. Co-channel interference test results.

2.15 References for Chapter 2

- 2a. Secretariat, Range Commanders Council. Telemetry Standards. White Sands Missile Range, New Mexico, RCC, latest edition (IRIG Standard 106).
<http://www.jcte.jcs.mil/RCC>
- 2b. Osborne W.P., Luntz M.B., "Coherent and Noncoherent Detection of CPFASK", IEEE Transactions on Communications, August 1974.
- 2c. Geoghegan M.S., "Improving the Detection Efficiency of Conventional PCM/FM Telemetry by using a Multi-Symbol Demodulator", Proceedings of the 2000 International Telemetry Conference, Volume XXXVI, 717-724, San Diego CA, October 2000.
- 2d. Kotelnikov, V. A. The Theory of Optimum Noise Immunity. Dover, New York, 1968.
- 2e. Gagliardi, R. M. Introduction to Communications Engineering. Wiley, New York, 1978.
- 2f. Tjhung, T. T., and Wittke, P. H. "Carrier Transmission of Binary Data in a Restricted Band," in IEEE Transactions on Communications, Vol. COM-18, pp. 295-304, August 1970.
- 2g. Cartier, D. E. "Limiter-Discriminator Detection Performance of Manchester and NRZ Coded FSK," in IEEE Transactions of Aerospace and Electronic Systems, Vol. AES-13, pp. 62-70, January 1977.
- 2h. Law, E.L. "Optimized Low Bit Rate PCM/FM Telemetry with Wide IF Bandwidths", Proceedings of the 2002 International Telemetry Conference, San Diego CA, October 2002.
- 2i. Korn, I. "Error Probability and Bandwidth of Digital Modulation," in IEEE Transactions on Communications, Vol. COM-28, pp. 287-290, February 1980.
- 2j. M. G. Pelchat, "The Autocorrelation Function and Power Spectrum of PCM/FM with Random Binary Modulating Waveforms," IEEE Transactions on Space Electronics and Telemetry, Vol. SET-10, No. 1, pp. 39-44, March 1964.
- 2k. A. D. Watt, V. J. Zurick, and R. M. Coon, "Reduction of Adjacent-Channel Interference Components from Frequency-Shift-Keyed Carriers," IRE Transactions on Communication Systems, Vol. CS-6, pp. 39-47, December 1958.
- 2l. Law, E. L., "RF Spectral Characteristics of Random PCM/FM and PSK Signals," International Telemetry Conference Proceedings, pp. 71-80, 1991.
- 2m. Tan, C. H., T. T. Tjhung, and H. Singh. "Performance of Narrow-Band Manchester Coded FSK With Discriminator Detection," in IEEE Transactions on Communications, Vol. COM-31, pp. 659-667, May 1983.

- 2n. Lindsey, W. C. and M. K. Simon. Telecommunication Systems Engineering, Prentice-Hall, Inc., Englewood Cliffs, NJ, p64, 1973.
- 2o. Law, E. and K. Feher, "FQPSK versus PCM/FM for Aeronautical Telemetry Applications; Spectral Occupancy and Bit Error Probability Comparisons", 1997 Proceedings of the International Telemetry Conference, Las Vegas, October 1997.
- 2p. Simon, M., Bandwidth-Efficient Digital Modulation with Application to Deep Space Communications, Monograph number 3, DESCANSO Monograph Series, JPL Publication 00-17, Jet Propulsion Laboratory, California Institute of Technology, 2001. This publication is available free via the Internet: <http://descanso.jpl.nasa.gov/Monograph/series3/complete1.pdf> (note: do not use WWW prefix for this URL).
- 2q. Simon, M., Bandwidth-Efficient Digital Modulation with Application to Deep Space Communications, John Wiley and Sons, Inc., 2003.
- 2r. Hogenauer, E., "An Economical Class of Digital Filters for Decimation and Interpolation," IEEE Transactions on Acoustics, Speech, and Signal Processing, Vol. ASSP-29, No. 2, April 1981.
- 2s. Temple, K., "Advanced Range Telemetry (ARTM) Tier I Compatible Demodulator Testing and Results", Proceedings of the International Telemetry Conference, San Diego, California, October 2002.
- 2t. Hill, T., "An Enhanced, Constant Envelope, Interoperable Shaped Offset QPSK (SOQPSK) Waveform for Improved Spectral Efficiency", Proceedings of the International Telemetry Conference, San Diego, California, October 2000.
- 2u. Younes B., Brase J., Patel C., Wesdock J., "An Assessment of Shaped Offset QPSK for Use in NASA Space Network and Ground Network Systems", Meetings of Consultative Committee for Space Data Systems, Toulouse, France, October, 2000.
- 2v. Geoghegan, M., "Implementation and Performance Results for Trellis Detection of SOQPSK", Proceedings of the International Telemetry Conference, Las Vegas, Nevada, October 2001.
- 2w. Geoghegan, M., "Description and Performance Results for the Advanced Range Telemetry (ARTM) Tier II Waveform", Proceedings of the International Telemetry Conference, San Diego, CA, October 2000.
- 2x. Taub, H. and D. L. Schilling. Principles of Communication Systems, McGraw-Hill, New York, pp 162-179, 1971.
- 2y. Gregg, W. D. Analog and Digital Communication, John Wiley and Sons, New York, pp 267-294, 1977.

- 2z. Downing, J. J. Aerospace Telemetry, Volume 1, (ed. by H. L. Stiltz), Prentice-Hall, Englewood Cliffs, NJ, pp 83-141, 1961.
- 2aa. Hochman, D. Handbook of Telemetry and Remote Control, (ed. by E. L. Gruenberg), McGraw-Hill, New York, pp 9-2 to 9-198, 1967.
- 2bb. Heberling, E. D. An Experimental Evaluation of the Characteristics of PAM-NRZ/FM Telemetry Systems, Naval Ordnance Laboratory Corona, Corona, California, September 1967. (NOLC Report 741).
- 2cc. Nichols, M. H. and Rauch, L.L. Radio Telemetry, J. Wiley, 1956.
- 2dd. Uglow, K. "Noise and Bandwidth in FM/FM Radio Telemetry", IRE Transactions, pp 19-22, May 1957.
- 2ee. Rosen, C. "System Transmission Parameters Design for Threshold Performance", in Proceedings of the International Telemetry Conference, Vol. XIX, pp 145-182, 1983.
- 2ff. Rechter, R.J. "Summary and Discussion of Signal-to-Noise Ratio Improvement Formulae for FM and FM/FM Links", in Proceedings of the International Telemetry Conference, Vol. III, pp 221-255, 1967.
- 2gg. Panter, P. F. Modulation, Noise, and Spectral Analysis, McGraw-Hill, New York, pp. 236-270, 1965.
- 2hh. Law, E. L., E. T. Kimball, and M. H. Nichols. "Relationship of Noise Power Ratio to FM/FM Data Quality", in Proceedings of the International Telemetry Conference, Vol. XII, pp 234-250, 1976.
- 2ii. Law, E. L., E. T. Kimball, and M. H. Nichols. Relationship of Noise Power Ratio to Subcarrier Discriminator Signal-to Noise Ratio, Pacific Missile Test Center, Point Mugu, CA, 1 Aug 1975. PMTC TP-75-21.
- 2jj. Lantz, N. F., and M. H. Nichols. "Approximate Design Formulae and Procedures for Designing Hybrid Telemetry Systems Using an FM Carrier", in Proceedings of the International Telemetry Conference, Vol. XIII, pp 261-271, 1977.
- 2kk. Howard W. Sams & Company, Inc., Reference Data for Radio Engineers, Indianapolis, IN, p 28-12, 1975.
- 2ll. Rice, M., A. Davis, and C. Bettweiser, Wideband Channel Model for Aeronautical Telemetry, in IEEE Transactions on Aerospace and Electronic Systems, vol. 40 No. 1, January 2004 pp 57-69.

- 2mm. Streich, R. G., D. E. Little, and R. B. Pickett. "Dynamic Requirements for Diversity Combiners", in Proceedings of the International Telemetry Conference, Volume 8, pp. 635-642, October 1972.
- 2nn. Law, E., Kingery, R. and Cramer, D., "Investigation of Telemetry and GPS Compatibility," Proceedings of the International Telemetry Conference, San Diego, CA, October 2000.
- 2oo. Crosby, M. G. "Frequency Modulation Noise Characteristics". Proc. IRE, 25, 472-514 (1937).
- 2pp. Stumpers, F. L. H. M. "Theory of Frequency-Modulation Noise". Proc. IRE, 36, 1081-1092 (1948).
- 2qq. Rice, S. O. "Noise in FM Receivers". Time Series Analysis, ed. M. Rosenblatt, pp. 395-422 (Wiley 1963).
- 2rr. Sklar, B. "What the System Link Budget Tells the System Engineer or How I Learned to Count in Decibels", in Proceedings of the International Telemetry Conference, Vol. XV, pp 331-344, 1979.
- 2ss. Law, E. L. Pulse Code Modulation Telemetry. Properties of Various Binary Modulation Types, Pacific Missile Test Center, Point Mugu, CA, TP000025, June 1984.
- 2tt. Law, E. L. Analog Frequency Modulation Telemetry, Pacific Missile Test Center, Point Mugu, CA, TP000042, September 1987
- 2uu. Geoghegan, M.; "Bandwidth and Power Efficiency Trade-offs of SOQPSK", Proceedings of the International Telemetry Conference, San Diego, CA, October 2002.
- 2vv. Jefferis, R.; "FQPSK-B Baseband Filter Alternatives", Proceedings of the International Telemetry Conference, San Diego, CA, October 2002.
- 2ww. Law, E.; "Adjacent Channel Interference Measurements with CPFSK, CPM, and FQPSK-B Signals", in Proceedings of the 2002 International Telemetry Conference, Las Vegas, Oct. 2002.
- 2xx. Butsch, Felix, "A Growing Concern Radiofrequency Interference and GPS", GPS World, October 2002.

CHAPTER 3

TELEMETRY TRANSMITTING SYSTEM CHARACTERIZATION

3.1 Introduction

This section will present a brief overview of telemetry transmitting systems followed by a discussion of system selection criteria and references. The telemetry transmitting system consists of the following major subsystems:

- a. Signal sources (frequently transducers)
- b. Signal conditioning
- c. Signal multiplexing (frequency and/or time division)
- d. Signal coding (if used)
- e. Modulation of carrier signal by multiplexed information signal (or recording of information signal on magnetic tape)
- f. Transmitting antenna

The above subsystems must be properly interfaced to each other and must be properly designed to provide the desired information. The transmitting system must also be compatible with the receiving, recording, and data processing facilities.

3.2 Overview of Telemetry Transmitting Systems

The basic function of a telemetry transmitting system is to convert one or more information sources into a predetermined format and to transmit the information to a receiving facility. The information might include the temperature at a certain location in a missile, the vibration at another point, the position of a fin, the voltage provided by a battery, the digital outputs from a computer, or almost anything else that one may want to monitor.

The first link in the telemetry chain is frequently a transducer. A transducer is a device that converts energy from one form to another. An example is the conversion of the temperature at a point on a missile to a voltage that can be multiplexed with other voltages. There are many different types of transducers available. The Vehicular Instrumentation/Transducer Committee of the Telemetry Group hosts a Transducer Workshop every two years. The proceedings of this workshop are also available from the RCC Secretariat. The North Atlantic Treaty Organization (NATO) Advisory Group for Aerospace Research and Development (AGARD) has also published a series of documents on transducers and flight instrumentation (Reference [3a](#)).

The transducer outputs usually need to be modified into the desired form for sampling and/or multiplexing. This signal conditioning can include amplification, level shifting, filtering, buffering, rectification, logarithmic amplification, and companding. These topics are addressed in books on analog design and instrumentation and will not be discussed here.

The conditioned information signals are then combined with other signals. This process is called multiplexing. The two most common types of multiplexing are frequency division multiplexing (FDM) and time division multiplexing (TDM). The FDM is frequently used in

simple systems where only a few channels of data are needed. It is also used in combination with TDM, especially for wideband vibration data. The conditioned information signals are applied to different, compatible subcarrier oscillators (SCOs). These SCO outputs are then added together to form one composite signal which then modulates the transmitter. FDM systems are discussed in paragraph [2.8](#).

Pulse code modulation (PCM) is the most popular form of TDM system. Various PCM systems are discussed in paragraphs [2.2](#), [2.3](#), [2.4](#), [2.5](#), [2.6](#), [2.8](#), and [2.9](#). The TDM systems sample the information signals at pre-determined times. Each signal has its own time slots for transmission. The sampling rate is typically 3 to 10 times the maximum expected signal frequency (References [3b](#), [3c](#), and [3d](#)). The required sampling rate is a function of the accuracy required, the roll-off rate of the signal and noise spectrums beyond the maximum expected signal frequency, and the type and roll-off rate of the anti-aliasing and signal reconstruction filters.

The telemetry transmitter converts the multiplexed signal into a modulated radio frequency (RF) signal. The output power is usually limited by the available supply current or the possibility of interference with other systems or signals. The transmitting antenna radiates the RF energy to the outside world.

3.3 Transmitting System Selection Guidelines

The type of transmitting system to use for a particular application depends upon the number of signals to be monitored, the signal bandwidths, the required data accuracy, and whether the signals are analog or digital signals. If a large number of different signals must be monitored, a PCM system is usually the best choice. If only a few analog signals need to be monitored, then an FM/FM system may be a good choice. The FM/FM (or analog FM if there is only one very wideband signal) is usually a good choice for wideband analog signals (such as vibration data).

PCM can provide the best data quality with strong received signals because it is immune to many of the problems which can occur in the telemetry system. If the received IF SNR is 15 dB or greater, the data at the bit synchronizer output is essentially the same as it was at the commutator output. However, as the IF SNR decreases, the data quality of PCM does degrade faster than most other systems. Error correction and detection coding can also be added to the transmitted PCM signal to extend the error free range. If much of the data to be transmitted is from digital computers or other digital data sources, PCM or a combination of PCM and FM/FM is the best method to consider. If the transmitted signal must be protected from unauthorized observers, PCM is also the best system to use. Overall, PCM is usually the best choice except for wideband analog signals. Most new telemeters use either PCM or a combination of PCM and FM/FM or PCM and analog FM. It is essential that the PCM standards of Reference [3e](#) be used as a guideline when designing PCM systems. Overly creative designs, which do not adhere to these standards, cause many problems for the telemetry processing systems and waste a lot of time and money.

The length of the PCM frame synchronization word, in a well-designed system, should be a minimum of 16 bits. Short synchronization patterns lead to a high probability of false acquisition or a low probability of correct acquisition with noisy data. Recommended synchronization patterns are included in Appendix C of Reference [3e](#). The probability of correctly detecting synchronization (Reference [3f](#)) with a BER of p (independent errors assumed), a pattern length of n bits, and allowing q errors is

$$P_{\text{sync}} = \sum_{r=0}^q \frac{n!}{(n-r)!r!} p^r (1-p)^{n-r}. \quad (3-1)$$

See Figure [3-1](#) and Figure [3-2](#) for synchronization pattern lengths of 16, 24, and 32 bits. The data in Figure 3-1 shows that if we desire to have a probability of 0.9 of detecting a 24-bit frame synchronization pattern when the BER is 0.1, we need to allow 4 errors in the pattern. If the BER is reduced to 0.01 (see Figure 3-2), we will have a probability of greater than 0.97 of detecting the pattern if we allow one error.

The probability of randomly detecting false synchronization with random data, a pattern length of n bits, and allowing q errors is

$$P_{\text{false sync}} = \frac{\sum_{r=0}^q \frac{n!}{(n-r)!r!}}{2^n}. \quad (3-2)$$

Figure [3-3](#) presents data on the probability of false detection of the synchronization pattern for pattern lengths of 16, 24, and 32 bits. Assume we have a PCM minor frame, which is 4000 bits long, and we would like the probability of detecting a false synchronization pattern in one minor frame time to be less than 0.2. The probability of false detection of the synchronization pattern in any location would have to be less than $0.2/4000$ or 0.00005. The data in Figure 3-3 shows that no errors could be allowed in search mode with a 16-bit pattern. However, two errors could be allowed with a 24-bit pattern and four errors could be allowed with a 32-bit pattern. If the BER is 0.1, the probability of detecting the actual synchronization pattern with a 16-bit pattern and 0 errors allowed is only 0.19. Consequently, we are more likely to detect a false pattern than the correct pattern, and the acquisition time may be long under these conditions. The probability of correctly detecting the 24-bit pattern while allowing 2 errors is 0.56, while the probability of correctly detecting the 32-bit pattern while allowing 4 errors is 0.79, which illustrates the advantage of long synchronization patterns when the data is noisy. It is extremely desirable to have the PCM decommutator synchronized to the transmission system's commutator because no useful data is possible when they are not synchronized.

The recommended peak deviations and premodulation filters for various types of systems are discussed in paragraphs 2.2 through 2.9. The transmitting system designer needs to be aware of the capabilities of the telemetry ground stations that will receive, record, and process the data. If possible, the transmitting system should be designed to be compatible with the ground stations. In the rare cases where this is not possible, the transmitting system designer needs to give the ground station the maximum possible lead-time to prepare for a new requirement. A link analysis (see paragraph 2.10) should also be done for the various scenarios that are expected.

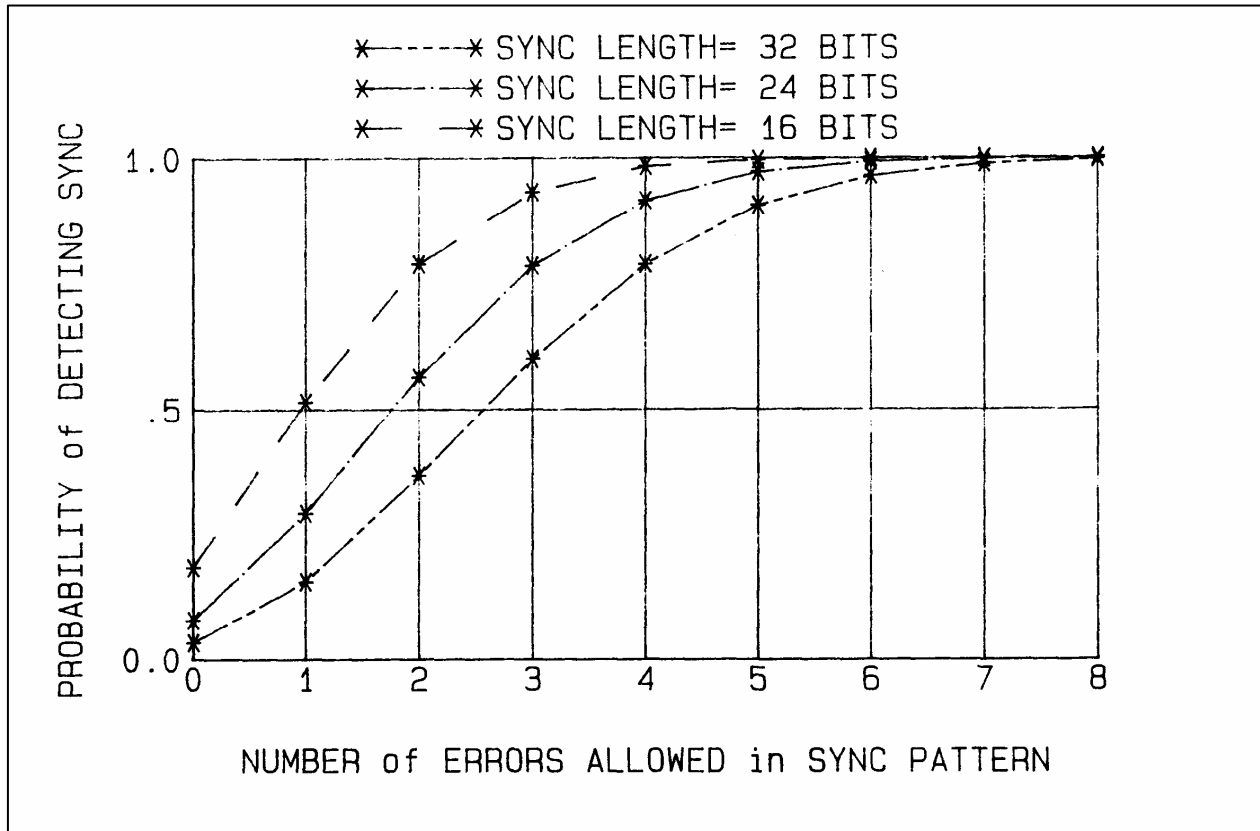

Figure 3-1. Probability of detecting sync pattern with BER = 0.1.

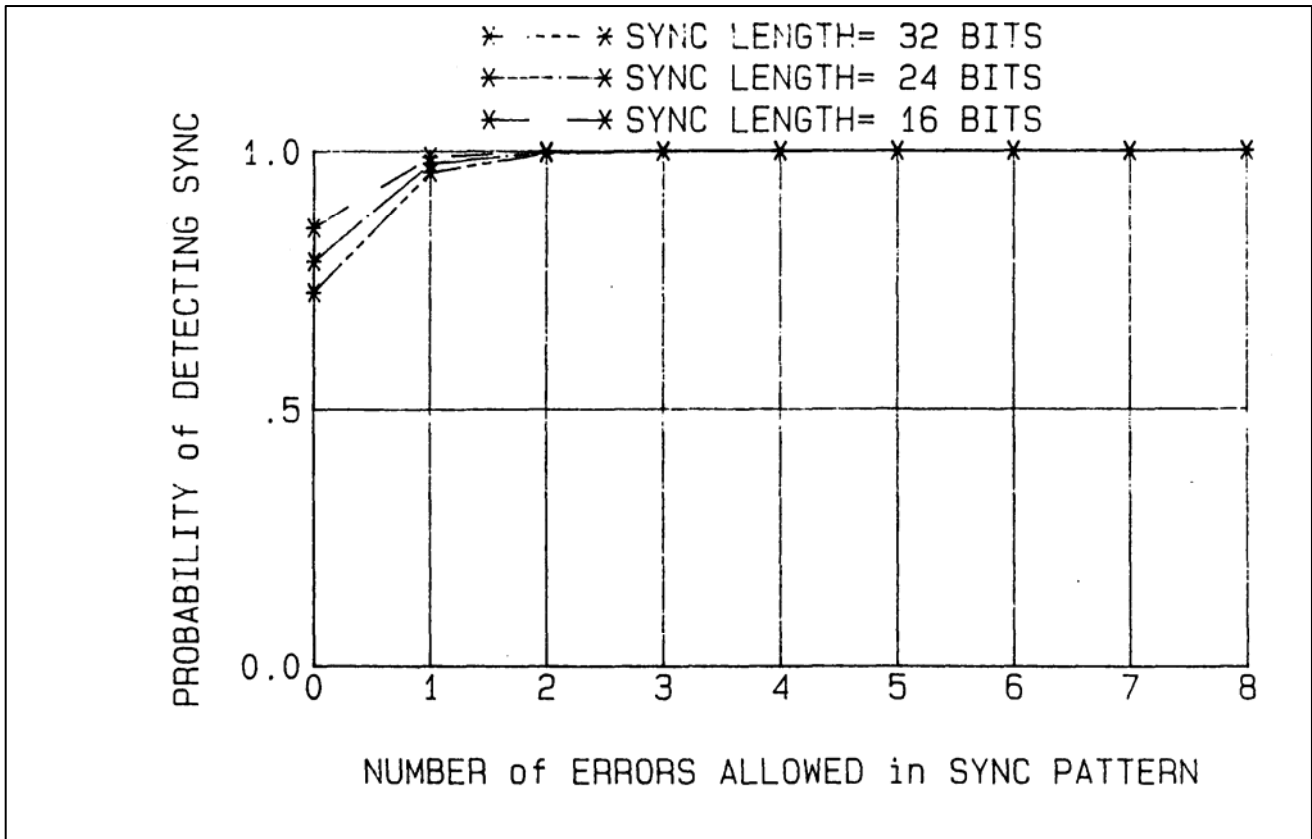

Figure 3-2. Probability of detecting sync pattern with BER = 0.01.

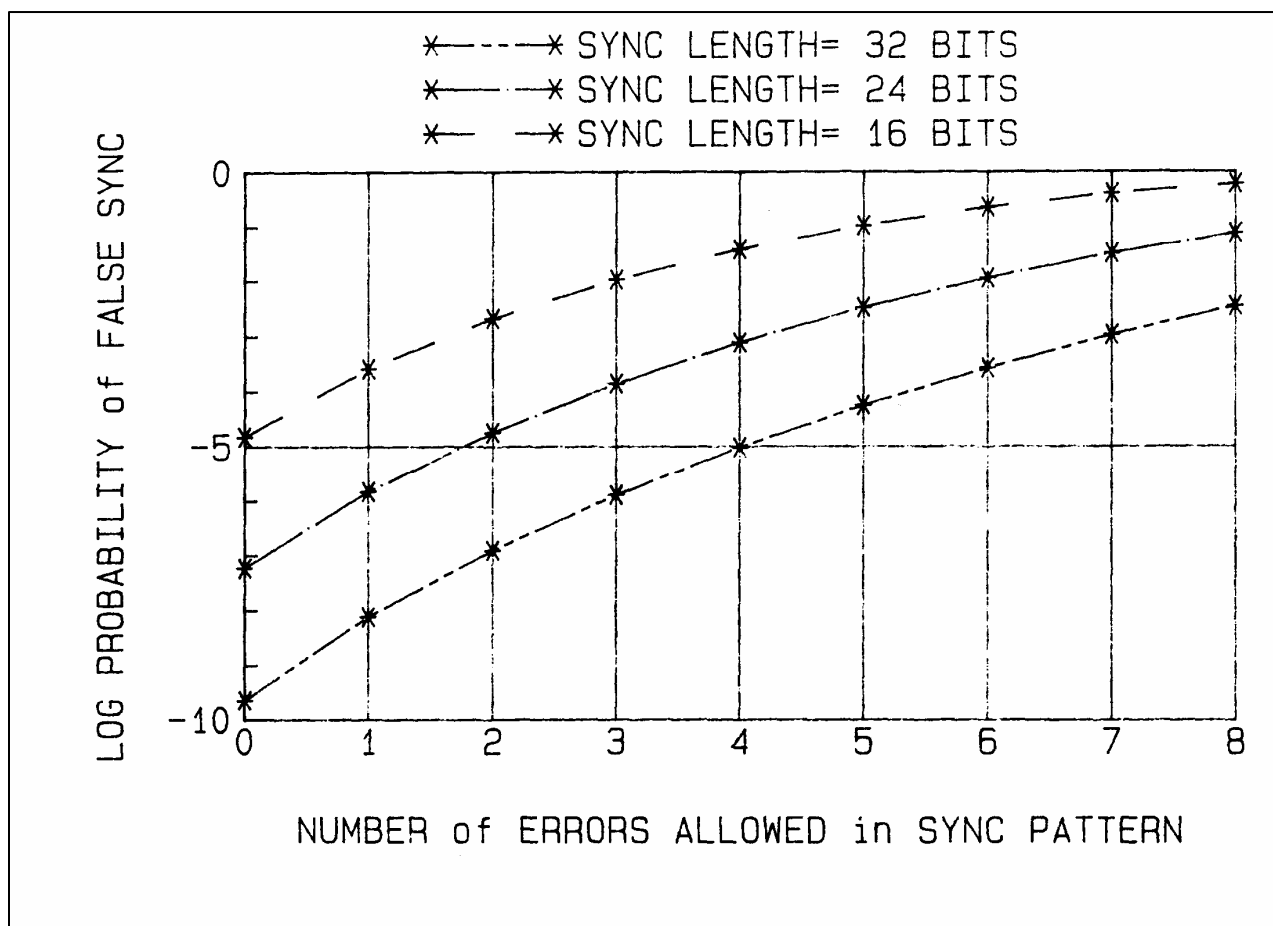

Figure 3-3. Probability of detecting false sync pattern.

3.4 References for Chapter 3

- 3a. Pool, A. and D. Bosnian ed. Basic Principles of Flight Test Instrumentation Engineering. North Atlantic Treaty Organization, Advisory Group for Aerospace Research and Development, AGARD-AG-160-Vol. 1, April 1974.
- 3b. Gardenhire, L. W. "Filtering and Sampling" in Basic Principles of Flight Test Instrumentation Engineering. ed. A. Pool and D. Bosman, North Atlantic Treaty Organization, Advisory Group for Aerospace Research and Development, AGARD-AG-160-Vol. 1 Chapter 6, April 1974.
- 3c. Capps, J. W., W. F. Link, C. D. Eatough, and D. G. Childers. Study and Experimental Investigation on Sampling Rate and Aliasing in Time-Division Telemetry Systems, by Aeronutronic for Wright-Patterson AFB, Ohio, Technical Report No. ASD-TR-61-553, June 1962.
- 3d. Gruenberg, E. L., Handbook of Telemetry and Remote Control., McGraw-Hill, New York, 1967.
- 3e. Secretariat, Range Commanders Council. Telemetry, Standards. White Sands Missile Range, New Mexico, RCC, July 2005 (IRIG Standard 106).
- 3f. Hill, E. R., "Techniques for Synchronizing Pulse-Code- Modulated Telemetry". Proceedings of the 1963 National Telemetry Conference, paper 3-3.
- 3g. Secretariat, Range Commanders Council. Directory of Transducer Users (Seventh Edition). White Sands Missile Range, New Mexico. (IRIG Document 100-86).
- 3h. Secretariat, Range Commanders Council. End-to-End Test Methods for Telemetry Systems. White Sands Missile Range, New Mexico. (IRIG Document 118-79 vol.1).
- 3i. Secretariat, Range Commanders Council. Test Methods for Vehicle Telemetry Systems. White Sands Missile Range, New Mexico. (IRIG Document 118-82 vol. V).
- 3j. Borek, R. W. Practical Aspects of Instrumentation System Installation. North Atlantic Treaty Organization, Advisory Group for Aerospace Research and Development, AGARD-AG-160- Vol. 13, September 1981.
- 3k. Basic Principles of Flight Test Instrumentation Engineering. A. Pool and D. Bosman ed., North Atlantic Treaty Organization, Advisory Group for Aerospace Research and Development, AGARD-AG-160-Vol. 1, April 1974.
- 3l. Gagliardi, R. M. Introduction to Communications Engineering. Wiley, New York, 1978.
- 3m. Tjhung, T. T., and P. H. Wittke. "Carrier Transmission of Binary Data in a Restricted

- Band," in IEEE Transactions on Communications, Vol. COM-18, pp. 295-304, August 1970.
- 3n. Cartier, D. E. "Limiter-Discriminator Detection Performance of Manchester and NRZ Coded FSK," in IEEE Transactions of Aerospace and Electronic Systems, Vol. AES-13, pp. 62-70, January 1977.
- 3o. Korn, I. "Error Probability and Bandwidth of Digital Modulation," in IEEE Transactions on Communications, Vol. COM-28, pp. 287-290, February 1980.
- 3p. Tan, C. H., T. T. Tjhung, and H. Singh. "Performance of Narrow-Band Manchester Coded FSK With Discriminator Detection," in IEEE Transactions on Communications, Vol. COM-31, pp. 659-667, May 1983
- 3q. Taub, H. and D. L. Schilling. Principles of Communication Systems, McGraw-Hill, New York, pp 162-179, 1971.
- 3r. Gregg, W. D. Analog and Digital Communication, John Wiley and Sons, New York, pp 267-294, 1977.
- 3s. Downing, J. J. Aerospace Telemetry. Volume I, (ed. by H. L. Stiltz), Prentice-Hall, Englewood Cliffs, NJ, pp 83-141, 1961.
- 3t. Handbook of Telemetry and Remote Control, E. L. Gruenberg ed., McGraw-Hill, New York, 1967.
- 3u. Heberling, E. D. An Experimental Evaluation of the Characteristics of PAM-NRZ/FM Telemetry Systems, Naval Ordnance Laboratory Corona, Corona, California, September 1967. (NOLC Report 741).
- 3v. Nichols, M. H. and L. L. Rauch. Radio Telemetry, J. Wiley, 1956.
- 3w. Uglow, K. "Noise and Bandwidth in FM/FM Radio Telemetry", IRE Transactions, pp 19-22, May 1957.
- 3x. Rosen, C. "System Transmission Parameters Design for Threshold Performance", in Proceedings of the International Telemetry Conference, Vol. XIX, pp 145-182, 1983.
- 3y. Rechter, R.J. "Summary and Discussion of Signal-to-Noise Ratio Improvement Formulae for FM and FM/FM Links", in Proceedings of the International Telemetry Conference, Vol. III, pp 221-255, 1967.
- 3z. Sklar, B. "What the System Link Budget Tells the System Engineer or How I Learned to Count in Decibels", in Proceedings of the International Telemetry Conference, Vol. XV, pp 331-344, 1979.

- 3aa. Lantz, N. F., and M. H. Nichols. "Approximate Design Formulae and Procedures for Designing Hybrid Telemetry Systems Using an FM Carrier", in Proceedings of the International Telemetry Conference, Vol. XIII, pp 261-271, 1977.
- 3bb. Capps, J. W., W. F. Link, C. D. Eatough, and D. G. Childers. Study and Experimental Investigation on Sampling Rate and Aliasing in Time-Division Telemetry Systems, by Aeronutronic for Wright- Patterson AFB, Ohio, Technical Report No. ASD-TR-61-553, June 1962.

This page intentionally left blank.

CHAPTER 4

TELEMETRY RECEIVING SYSTEM CHARACTERIZATION

4.1 Overview

This section will discuss the performance characteristics of telemetry-receiving and recording systems. The discussions will be brief and will include references to more detailed discussions. A simplified block diagram of a telemetry-receiving and recording system is shown in Figure [4-1](#).

4.1.1 Gain/System Noise Temperature (G/T). The receiving system sensitivity is commonly specified as the system G/T. The G/T is usually obtained by measuring the power from a hot and a cold signal source. The sun is frequently used as the hot source (P_{sun}) and the sky as the cold source (P_{sky}). This technique is presented in IRIG document 118 (Reference [4a](#)). The system G/T is very useful for problem detection and link analysis. One equation for calculating the system G/T is

$$G/T = 10 \log \left\{ \frac{8\pi k L P_r}{F \lambda^2} \right\} \quad (4-1)$$

where

$$k = 1.38 \times 10^{-23} \text{ watts/}^\circ\text{K/Hz}$$

$$L = 1 + 0.38 (0.5 / \text{antenna half-power beamwidth in degrees})^2$$

$$P_r = (P_{\text{sun}} / P_{\text{sky}}) - 1$$

$$F = \text{Solar flux at test frequency}$$

$$\lambda = \text{Wavelength of test frequency in meters.}$$

The aperture correction factor (L) used above is based on the use of a simultaneous lobing antenna. The solar flux is measured daily at 1415 (F_{1415}) and 2695 (F_{2695}) MHz along with several other frequencies. The current solar flux values can be found at <http://www.sec.noaa.gov/ftplib/latest/curind.txt>. There are several methods for estimating the flux at the test frequency from the measured flux at other frequencies (See References [4a](#), [4b](#), and [4c](#)). The "best" estimate appears to be

$$F = F_{2695} (F_{1415} / F_{2695})^\Gamma \quad (4-2)$$

where

$$\Gamma = \frac{\log (f / 2695)}{\log (1415 / 2695)}$$

$$f = \text{Test frequency (MHz).}$$

If we measure the following values at a frequency of 2250.5 MHz,

$$P_{\text{sun}} = 100 \text{ microwatts}$$

$$P_{\text{sky}} = 4 \text{ microwatts}$$

and the solar flux values are

$$F_{1415} = 60 \times 10^{-22} \text{ and } F_{2695} = 80 \times 10^{-22} \text{ W/m}^2/\text{Hz},$$

then

$$G/T = 10 \log \left\{ \frac{8 (3.1416) (1.38 \times 10^{-23}) (1.1) (100/4 - 1)}{80 \times 10^{-22} (60/80)^{0.28} (3.0 \times 10^8 / 2.2505 \times 10^9)^2} \right\}$$

$$G/T = 18.4 \text{ dB/}^\circ\text{K}$$

The system sensitivity can also be determined by using a controlled source at a known distance. This method is not dependent on time of day.

4.1.2 Bit Error Rate Testing. The performance of the telemetry-receiving and recording system can be checked by performing a bit error rate (BER) test. This test consists of modulating an RF generator with the standard IRIG 2047-bit pseudo-random sequence. The RF generator output is applied either to the preamplifier or to a boresight tower. The RF power can be varied and the BER measured at the receiver and recorder outputs. The results can be compared to the theoretical value or previous test results. This test is described in detail in IRIG Document 118, volume IV, Chapter 2 (Reference [4d](#)).

4.1.3 Noise Power Ratio Testing. The performance of the telemetry-receiving and recording system can also be checked by performing a noise power ratio (NPR) test. This test uses band-limited noise to simulate an FM/FM multiplex. (This test is also described in reference [4d](#)). The NPR test and some applications are also discussed in paragraph [2.8](#). The NPR test is sensitive to moderate levels of noise, intermodulation distortion, phase noise, nonlinearities, spurious signals, improper bandwidths, and equipment failures.

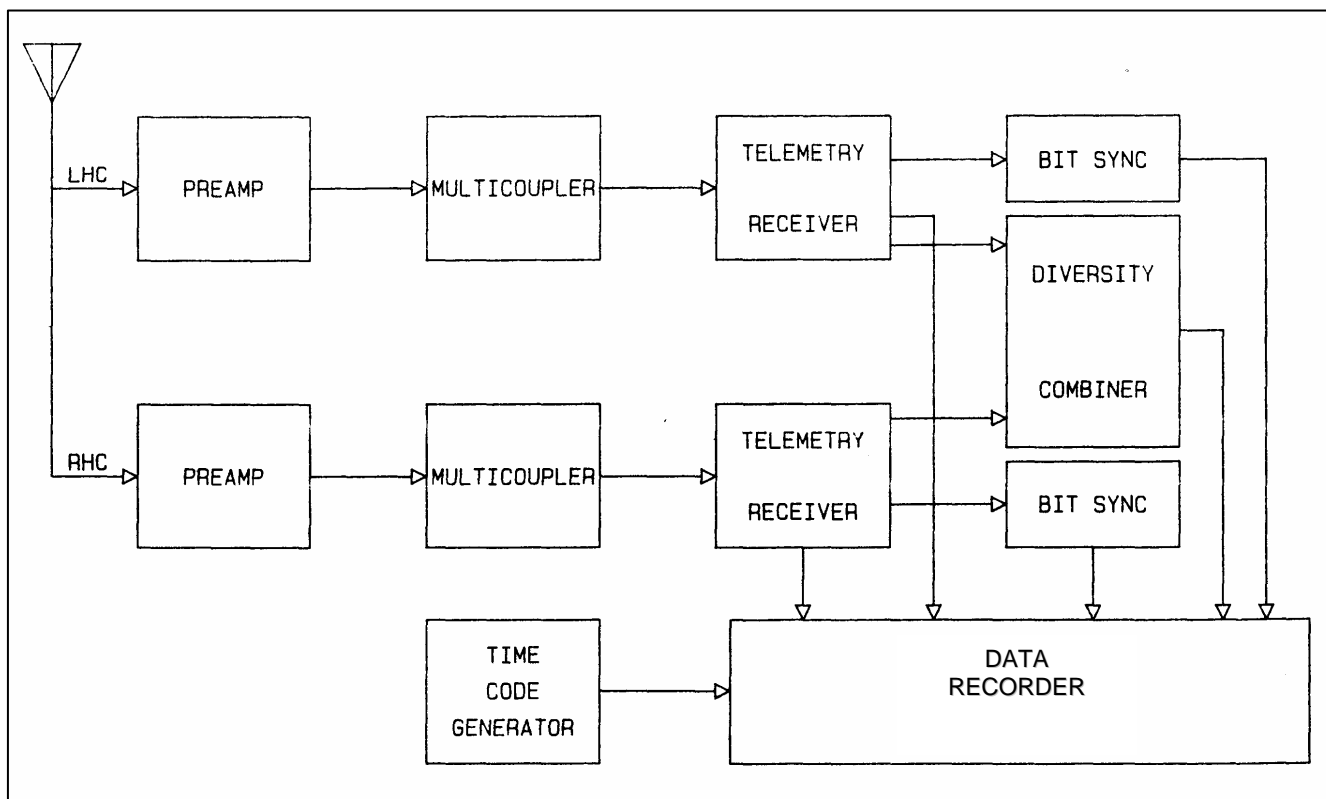

Figure 4-1. Simplified telemetry receive/record station.

4.2 Receiving Antennas

The telemetry-receiving antenna collects the impinging electromagnetic energy and makes it available for further processing. The important characteristics of a telemetry-receiving antenna include gain, beamwidth, frequency, polarization, sidelobe levels, tracking performance, and noise contribution.

4.2.1 Gain. The power gain of a parabolic dish telemetry-receiving antenna can be approximated by the following (see References [4e](#) and [4f](#)):

$$G = 0.5(\pi D/\lambda)^2, \quad (4-3)$$

where

D is the diameter of the antenna

D and λ are in the same units

Antenna efficiency is assumed to be 50 percent

The approximate gain of an 8-foot dish at 2250 MHz would be

$$G = 1654 \text{ or } 32.2 \text{ dBi}$$

Gain is plotted as a function of diameter in Figure [4-2](#).

4.2.2 Beamwidth. The 3-dB beamwidth (degrees) of an antenna can be approximated by the following (see Reference 4e and Reference 4f):

$$\theta = 70\lambda/D. \quad (4-4)$$

This gives an approximate beamwidth of 3.8° for an 8-foot dish at 2250 MHz. Beamwidth is plotted as a function of diameter in Figure 4-3.

4.2.3 Noise Temperature. The noise temperature of a parabolic dish antenna at 2250 MHz varies from approximately 200 °K for a 0° elevation angle to as little as 10 °K at large elevation angles.

4.2.4 Polarization. Most telemetry-receiving antenna systems are configured to receive two orthogonal polarizations. These polarizations are typically left- and right-hand circular or vertical and horizontal. Any set of two orthogonal polarizations contains all of the available power.

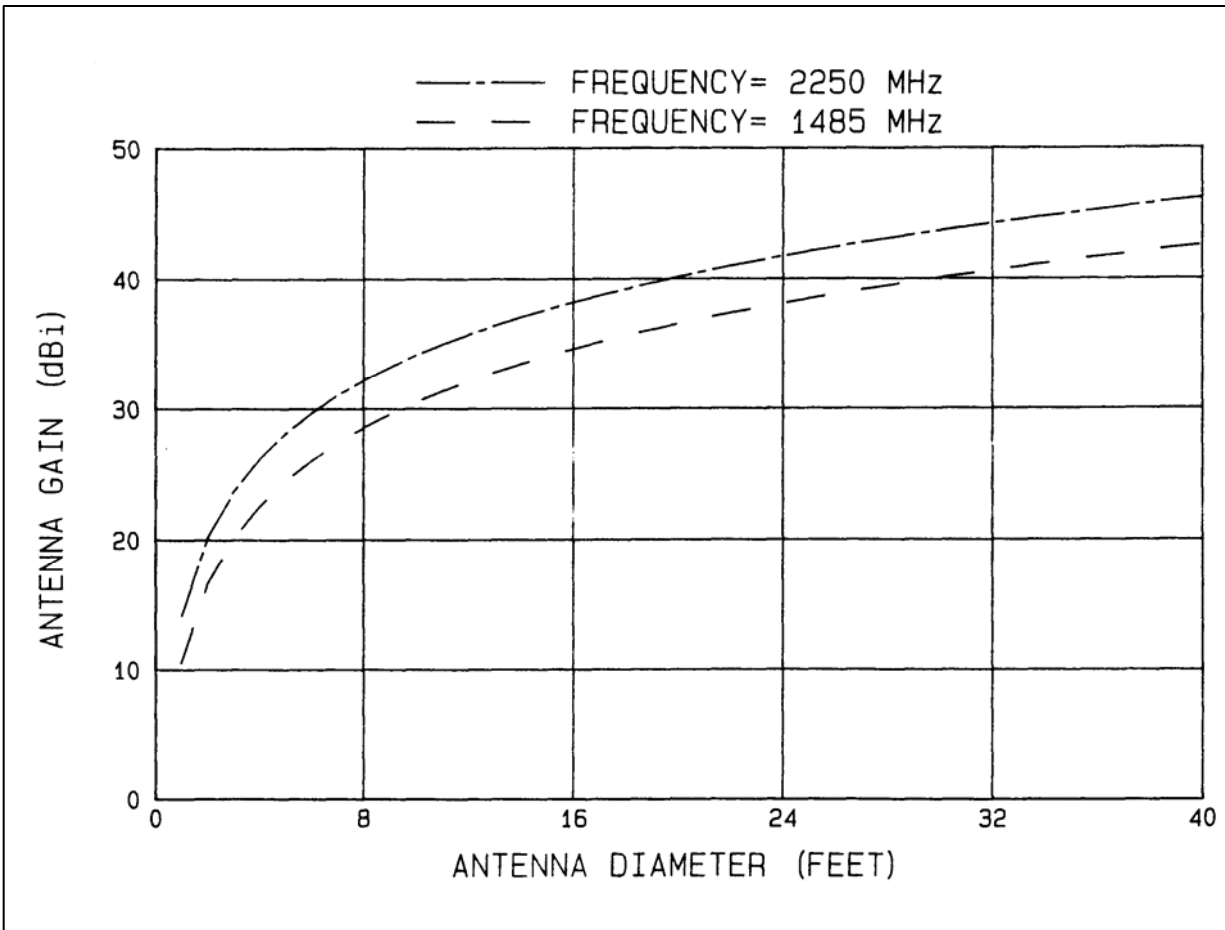

Figure 4-2. Antenna gain versus diameter (50 percent efficiency).

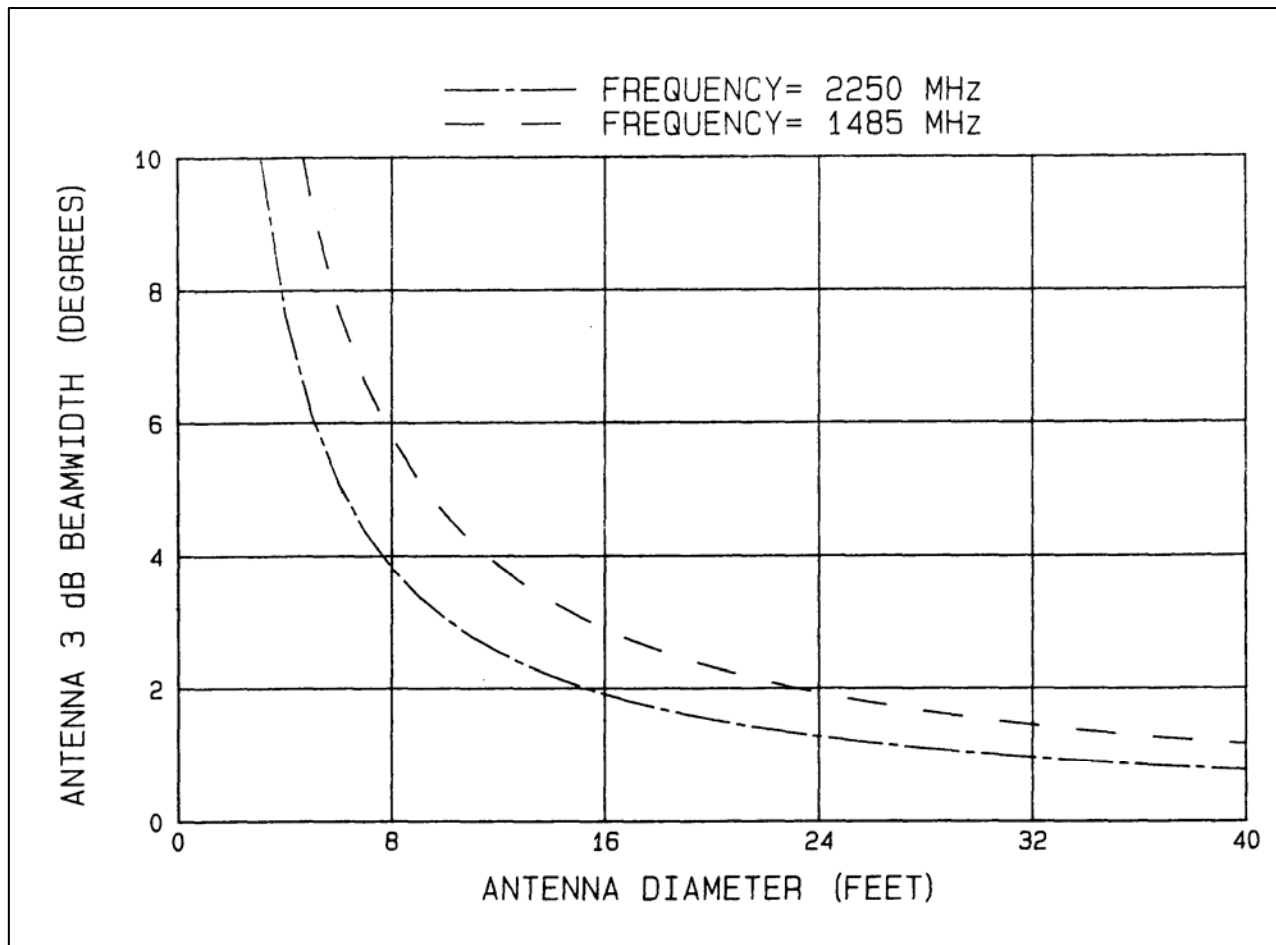

Figure 4-3. Antenna beamwidth versus diameter (50 percent efficiency).

4.3 Preamplifiers, Downconverters, and Multicouplers

4.3.1 Preamplifier. The purpose of the preamplifier is to amplify the signals received by the antenna while adding as little extra noise as possible. Therefore, the preamplifier should be mounted very near the antenna to minimize attenuation prior to amplification. The noise temperature (noise figure) of the preamplifier should be low to minimize the noise power. System noise temperatures are often specified at the preamplifier input. The preamplifier is often preceded by a bandpass filter and/or limiter to minimize the interference from strong out-of-band signals. A directional coupler is also frequently placed in front of the preamplifier to allow test signals to be injected at the preamplifier input.

4.3.2 Noise Figure/Noise Temperature. The noise figure (F) is a measure of the noise added by a device. It is defined (References [4g](#), [4h](#), and [4i](#)) as the ratio of total output noise to output noise only because of input noise when the input source is at a specified temperature of 290 °K.

$$F = 1 + T_e/290 \quad (4-5)$$

$$F \text{ (dB)} = 10 \log (1 + T_e/290) \quad (4-6)$$

where

T_e is the effective noise temperature of the device.

The noise figure (dB) of a lossy cable at room temperature is equal to the cable loss (dB). Therefore, a cable with 1 dB attenuation has an effective noise temperature of $(100^{0.1} - 1) 290 = 75$ °K when the cable is at a temperature of 290 °K. If the cable is at a different temperature, the noise temperature is calculated by replacing 290 by the actual cable temperature.

If a signal passes through a series of devices each with a separate gain G_i , noise figure F_i , and noise temperature T_{ei} , the overall noise figure and temperature are

$$F = F_1 + (F_2 - 1)/G_1 + (F_3 - 1)/G_1 G_2 + \dots \quad (4-7)$$

$$T_e = T_{e1} + T_{e2}/G_1 + T_{e3}/G_1 G_2 + \dots \quad (4-8)$$

As an example, analyze the system shown in Figure [4-4](#). Use the preamplifier input as a reference point. Combine the bandpass filter (BPF), directional coupler, and cable losses together to get a loss of 0.9 dB before the preamplifier.

| | | |
|----------------------------------|-----------------------|---------------|
| Antenna: | $T_A = 70$ °K | |
| BPF, directional coupler, cable: | $F_1 = 0.9$ dB = 1.23 | $G_1 = 0.81$ |
| Preamplifier: | $F_2 = 1.0$ dB = 1.26 | $G_2 = 1000$ |
| Cable: | $F_3 = 12$ dB = 15.85 | $G_3 = 0.063$ |
| Receiver: | $F_4 = 9$ dB = 7.94 | |

Calculate the equivalent system noise temperature as follows:

$$\begin{aligned} T_1 &= (1.23 - 1) 300 = 69.0 \text{ °K} \\ T_2 &= (1.26 - 1) 290 = 75.4 \text{ °K} \\ T_3 &= (15.85 - 1) 290 = 4306.5 \text{ °K} \\ T_4 &= (7.94 - 1) 290 = 2012.6 \text{ °K} \end{aligned}$$

$$T_{\text{system}} = 70/1.23 + 69.0/1.23 + 75.4 + 4306.5/1000 + 2012.6/63$$

$$T_{\text{system}} = 56.9 + 56.1 + 75.4 + 4.3 + 31.9 = 224.6 \text{ °K.}$$

The system noise temperature can be changed by varying the gain or noise temperature (or both) of the system components. Increasing the noise figure of the receiver to 12 dB would increase the system noise temperature by 36° and reduce the sensitivity by 0.6 dB. Increasing the gain of the preamplifier by 6 dB would decrease the system noise temperature by 27° and increase the sensitivity by 0.6 dB. Decreasing the loss before the preamplifier by 0.2 dB would decrease the noise temperature by 10° and increase the sensitivity by 0.4 dB (0.2 dB because of less noise and 0.2 dB because of more signal).

If we assume the antenna gain is 32.2 dBi, the system G/T can be calculated from the ratio of the effective signal gain at the preamplifier input to the effective system noise temperature at the preamplifier input as

$$G/T = (32.2 - 0.9) - 10 \log (224.6)$$

$$G/T = 7.8 \text{ dB/K}$$

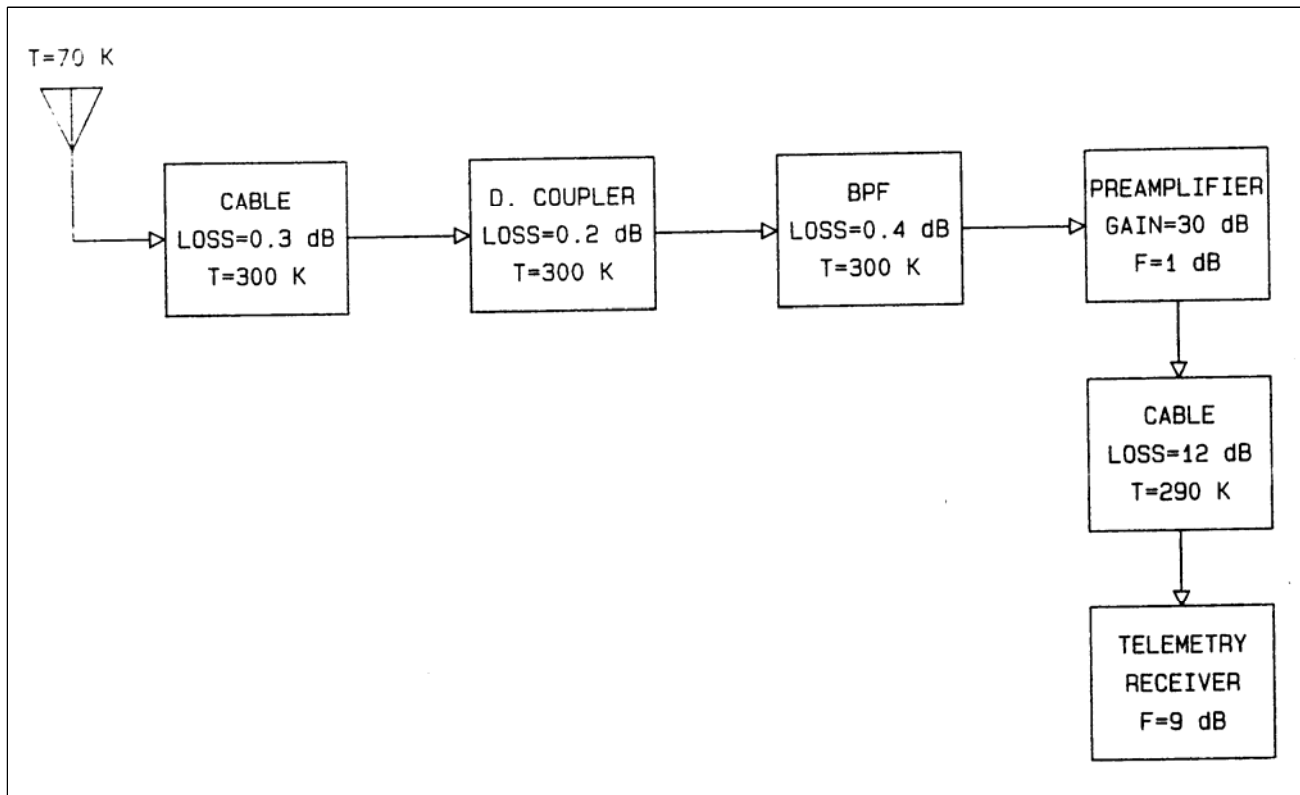

Figure 4-4. Receiving system noise temperature.

4.3.3 Downconverter. The purpose of the downconverter is to translate the input signal to a lower frequency. A typical example is to translate the 2200 to 2300 MHz band to 215 to 315 MHz, which is useful because it reduces the cable loss (dB) by a factor of approximately three (3). Telemetry signals are currently transmitted in four separate bands; they are 1435 to 1525 MHz, 1755 to 1850 MHz, 2200 to 2290 MHz, and 2360 to 2395 MHz. If the signals are all downconverted to 215 to 320 MHz, then a single receiver tuner can be used for all four

telemetry bands. The disadvantage is that a separate cable is needed for each frequency band after the downconverter. The important parameters include noise figure, VSWR, gain, 1 dB gain compression point, 60 dB intermodulation distortion point, bandwidth, gain, and local oscillator stability, accuracy, and phase noise.

4.3.4 Multicoupler. The purpose of the multicoupler is to provide several isolated outputs from one input, which allows one RF signal to be applied to several receivers. These receivers can be redundantly receiving one signal or be tuned to several frequencies. The important parameters include noise figure, VSWR, 1 dB gain compression point, 60 dB intermodulation distortion point, bandwidth, gain, and isolation between outputs.

4.4 Telemetry Receivers and Diversity Combiners

4.4.1 Introduction. A telemetry receiver takes an incoming radio frequency (RF) signal and translates the desired portion of the spectrum to a lower frequency. This lower frequency is called the final intermediate frequency (IF) frequency. Most telemetry receivers include two or three stages of frequency translation. The multiple stages make it easier to reject image and spurious signals. The final IF output of modern receivers is typically 70 MHz, while older receivers often have final IF frequencies of 10 or 20 MHz. This signal is then routed to a demodulator (FM, AM, PM, or PSK), a predetection downconverter, and frequently a diversity combiner. The demodulated or predetection signals are recorded and sent to the data processing and display facility.

The important characteristics of a telemetry receiver include:

- a. Frequency accuracy, stability, and phase noise.
- b. Noise figure
- c. Overall amplitude and phase response
- d. Spurious and image rejection
- e. Automatic gain control (AGC) linearity, stability, and transient response
- f. Demodulator linearity, stability, acquisition time, and noise performance

Diversity signal combining is a method of "adding" two or more independent signals. The most common type of diversity in telemetry signals is polarization diversity. Most telemetry-receiving antennas have two independent outputs, usually left- and right-hand circular polarization or horizontal and vertical polarization. A properly aligned predetection polarization diversity combiner will allow the receiving system to perfectly match the polarization of the incoming signal. Another common type of telemetry diversity is space diversity. This involves the use of two or more separate telemetry antennas. The signals from these antennas are typically selected rather than combined because of the problems encountered in keeping the signals time aligned. Space diversity is especially helpful when multipath or flame attenuation is encountered. Other types of diversity include frequency and time diversity.

The two types of telemetry combiners are predetection combiners and postdetection combiners. A predetection polarization diversity combiner must phase align the input signals and then weight the signals proportionally to the ratio of the signal to mean square noise in each channel. A postdetection polarization diversity combiner does not have to phase align the signals. However, the signals still need to be time aligned. Most telemetry combiners weight

the signals based on the receiver AGC voltages. A wideband AM signal can be summed with the AGC signal (Reference [4j](#)) to improve performance when the RF signal fluctuates in amplitude rapidly. Another method of combiner weighting is to use detected noise to weight the channels.

4.4.2 Receiver Noise Figure. The receiver is usually preceded by amplifiers with low noise figures. As long as the net gain between the input to the first amplifier and the input to the receiver is large, the effect of the receiver noise Figure is small because the receiver noise contribution is proportional to the receiver noise temperature divided by the net power gain. Typical receiver noise figures vary from 6 to 12 dB.

4.4.3 Receiver Local Oscillators. Most new telemetry receivers include synthesized local oscillators. This usually means that the receiver's frequency accuracy and stability versus time and temperature is good (provided that the basic crystal does not drift). Frequency synthesizers can have problems with phase noise and spurious signals. These problems can usually be detected by monitoring the local oscillator output using a spectrum analyzer.

4.4.4 Receiver IF and Video Filters. The overall frequency and phase response of the receiver predetection and video outputs are largely determined by the IF bandpass filters and the lowpass filters at the video and predetection outputs. The step response of linear phase filters is better than that of maximally flat amplitude response filters, which is especially important when receiving signals with baseband PAM. The standard IRIG IF bandwidths are 300, 500, 750, 1000, 1500, 2400, 3300, 4000, 6000, 10,000, 15,000 AND 20,000 kHz. All IF bandwidths are probably not available at one receiving site. The "best" choices of receiver bandwidths for various received signals are discussed in [Chapter 2](#) of this handbook. A sample receiver IF filter amplitude versus frequency response is shown in Figure [4-5](#). The output amplitude rolls off rapidly outside of the 3 dB passband.

4.4.5 AGC Time Constant. The receiver AGC time constant for data receivers should be the fastest available (usually 0.1 ms). Fast AGC time constants minimize the amount of time the receiver is captured by noise during signal fades and saturated during signal increases. There do not seem to be any disadvantages of fast AGC time constants for data receivers. (Receiver assumed to be stable for all available time constants.)

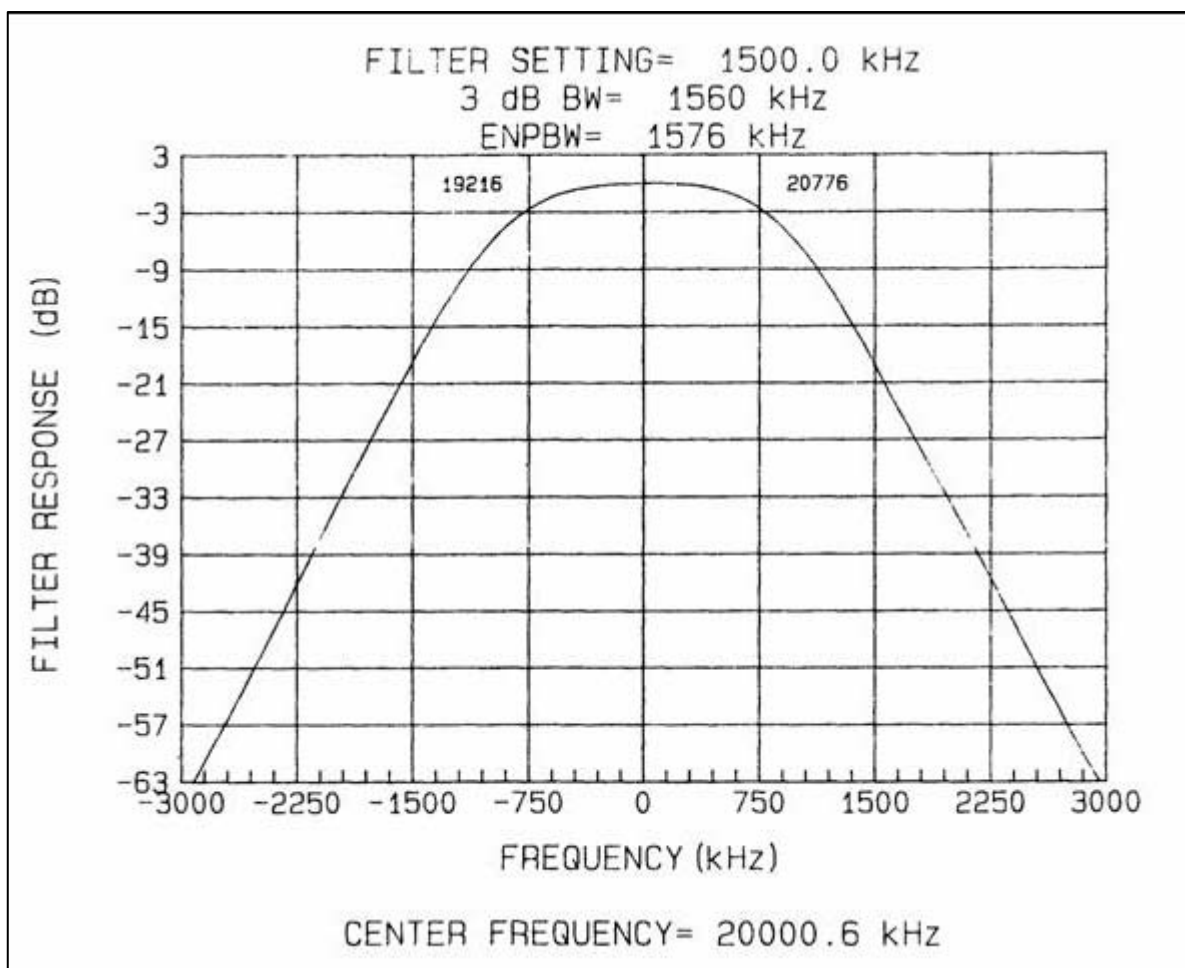

Figure 4-5. Sample receiver IF filter amplitude response.

4.4.6 Demodulator Loop Bandwidth (PM and PSK). The best loop bandwidth is a function of expected fade rate, frequency stability, and data rate. If flame attenuation is expected, a relatively wide loop bandwidth should be used, for example, 10 kHz. The disadvantage of wide loop bandwidths is that a higher IF SNR is required to keep the loop in lock. If the signal is predetection recorded, the loop bandwidth can be varied in post-flight mode to recover the maximum amount of data.

4.4.7 Automatic Frequency Control (AFC).. The receiver AFC circuit attempts to keep the incoming signal centered within the receiver passband; however, using AFC at low IF SNRs usually degrades the data quality. Another problem with AFC occurs when two receivers with independent local oscillators in AFC mode are used with a predetection combiner. The AFC circuits introduce excess phase modulation which the combiner phase-locked loop (PLL) has difficulty tracking.

4.4.8 Predetection Carrier. The predetection carrier signal is a replica of the RF signal which has been bandpass filtered and translated to a lower frequency. The predetection carrier is mainly used to record a replica of the transmitted signal with the least processing before recording. This allows the data reduction center to modify bandwidth and demodulator parameters to attempt to improve data quality. Once the data has been demodulated using less

than optimum parameters, it is usually impossible to correct the degradation! One example of this is the use of a PM demodulator loop bandwidth that is too wide to track the incidental phase changes that occur during a mission. Each time the demodulator loses lock, the data will be useless until lock is reacquired; therefore, predetection recording is often specified by the data users. The IRIG 106 standard predetection carrier center frequencies are 112.5, 150, 225, 300, 450, 600, 900, 1200, 1800, and 2400 kHz (normally, frequencies of 450 kHz and higher are used). The receiver IF bandwidth should be less than or equal to twice the predetection carrier center frequency. The disadvantage of predetection recording is that it requires at least twice the bandwidth of baseband recording techniques. This is a problem for missions that last a long time and missions with wide data bandwidths. The preferred method of demodulation is to use an upconverter and playback receiver. Unfortunately, this hardware is not available at many telemetry data reduction centers. These centers usually use tunable discriminators. These discriminators have less frequency response capability than playback receivers do; additionally, their bandpass filter response characteristics are often not very good.

4.4.9 Pop Noise Symmetry. Pop noise is discussed in paragraph [2.12](#) of this handbook. If the receiver is improperly tuned or the IF filter characteristic is non-symmetrical the pop noise will be non-symmetrical.

4.4.10 Signal Strength. The receiver AGC voltages are linearly related to input signal power from approximately a +6 dB SNR (lower if a synchronous detector is used) to a high signal level. Properly calibrated AGC voltages provide a good indication of the received SNR at a given time. Since the AGC system responds to power at the receiver input rather than to SNR, the AGC signal is only a relative measure of SNR until it is calibrated. Many receiver AGC systems tend to be influenced by temperature; consequently, the AGCs are not stable until the receiver temperature stabilizes. The AGC signals are typically used as weighting signals for diversity combiners and as inputs to antenna tracking systems. In addition, the AGC signals are usually FM multiplexed with the timing and voice signals and recorded on the magnetic tape along with the telemetry data.

4.4.11 Diversity Combining. An optimal ratio diversity predetection combiner has a theoretical output SNR (power ratio) equal to the sum of the input SNRs (expressed as power ratios). This improvement results from adding the signals coherently while adding the noise non-coherently. The theoretical improvement that can be achieved by an optimal ratio predetection combiner relative to the best input signal is shown in Figure [4-6](#) for differences in input SNR between 0 and 10 dB. The theoretical improvement that can be achieved by an optimal ratio predetection combiner relative to a given fixed input signal is shown in Figure [4-7](#) for the independent signal varying from 10 dB worse than the reference to 10 dB better than the reference. A properly designed and aligned predetection combiner used with a properly matched receiving system performs very close to the theoretical limit. However, the AGC systems in many telemetry receivers tend to change with receiver temperature and tuning frequency. Therefore, the combiner and the receiving system need to be carefully aligned for optimum performance. The degradation from optimum performance for a 3 dB weighting error is shown in Figure [4-8](#). This data shows that 0.5 db is the maximum degradation from optimum with a 3 dB weighting error. The maximum degradation with a 6 dB weighting error is 2 dB. The degradation from optimum performance for phase alignment errors between 0 and 90° is shown in Figure [4-9](#). The degradation is approximately 0.5 dB with a 40° misalignment and 3 dB with a 90° misalignment.

A two-channel polarization diversity combiner can offer more than 3 dB of improvement relative to one of the incoming polarizations. The amount of improvement depends on the transmitting antenna design and the aspect angle between antennas. Typical values (see Reference [4k](#) for circular polarization reception and random aspect angles) are shown in Table 4-1.

| TABLE 4-1. TYPICAL IMPROVEMENT OF POLARIZATION DIVERSITY COMPARED TO SINGLE CHANNEL FOR MISSILE ANTENNAS. | |
|--|---|
| Percent Coverage | Improvement over single channel (dB) |
| 50 | 3 |
| 90 | 5 |
| 95 | 7 |
| 99 | 9 |

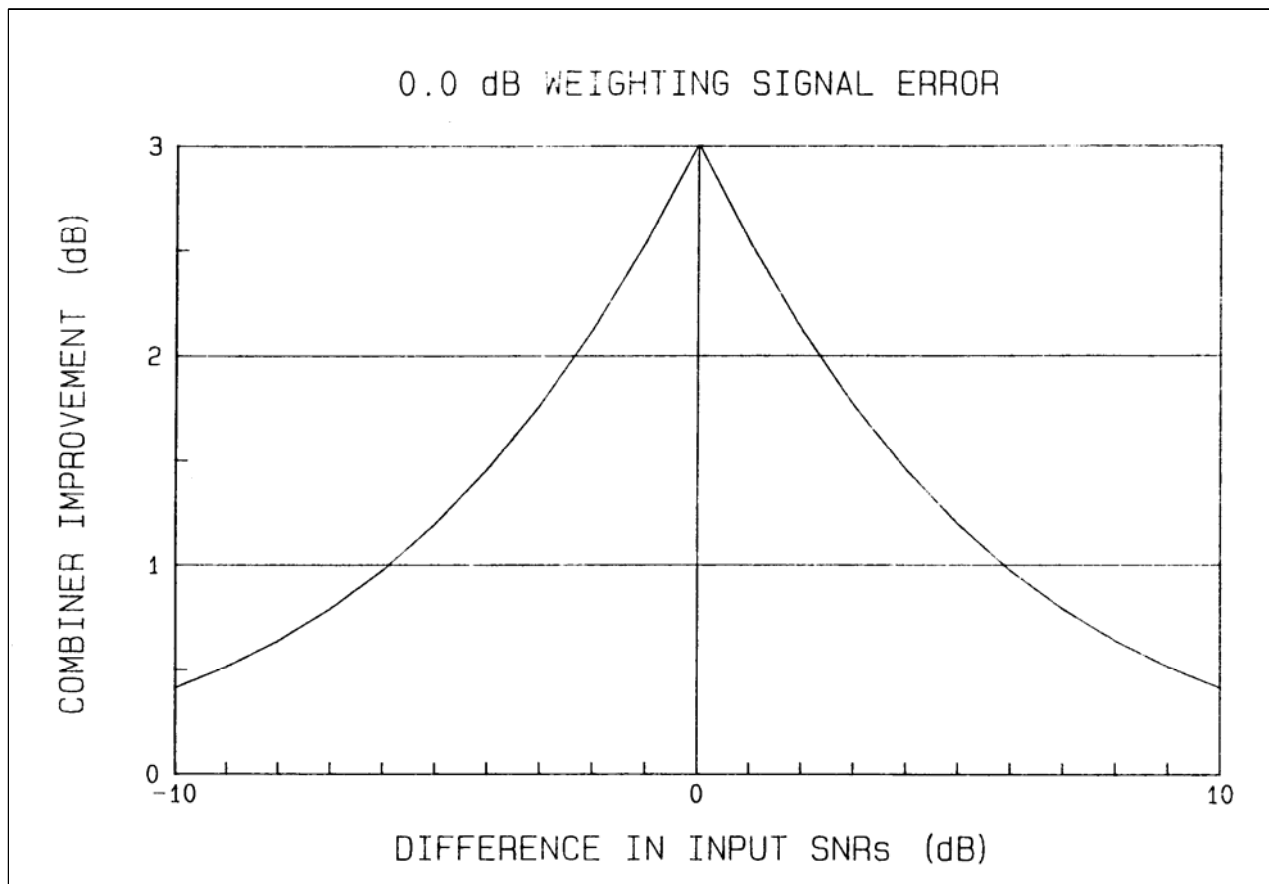

Figure 4-6. Combiner improvement relative to best input signal.

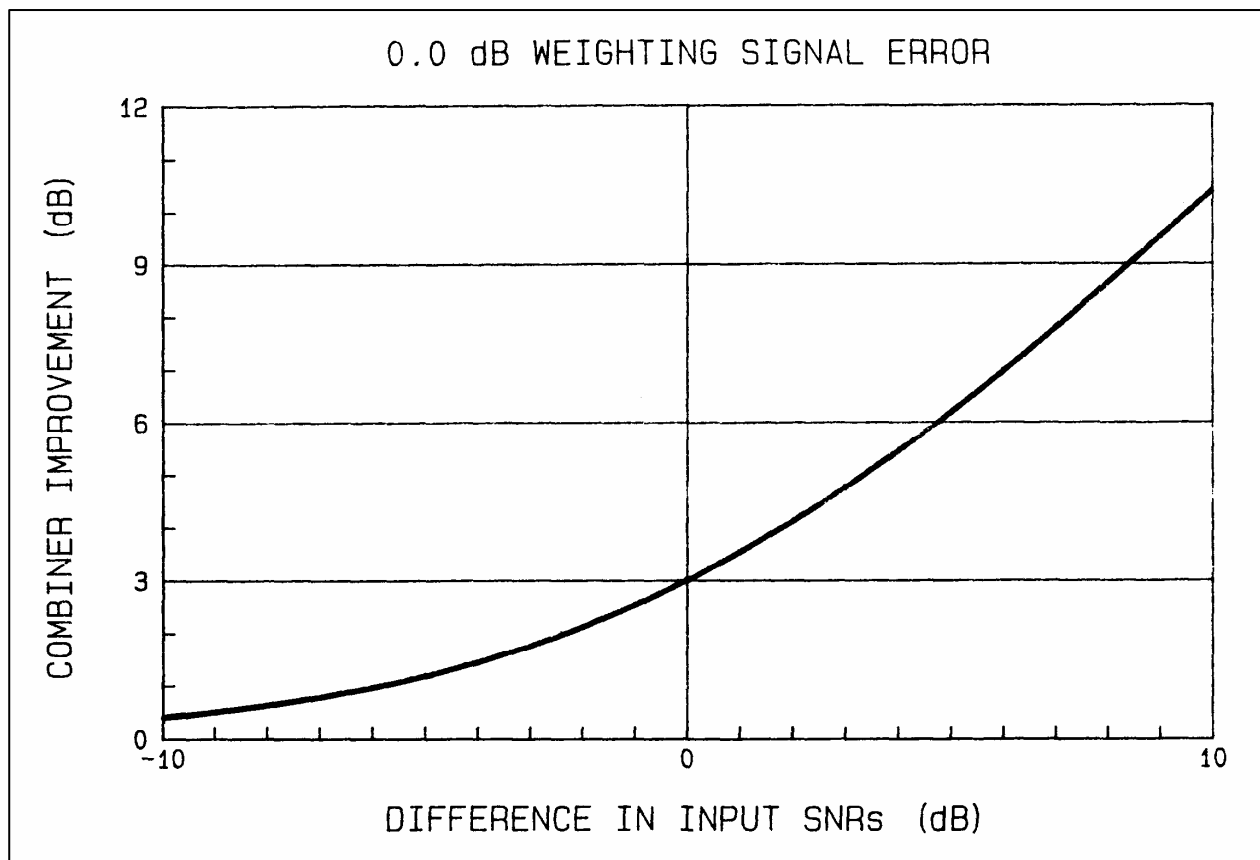

Figure 4-7. Combiner improvement relative to fixed input signal.

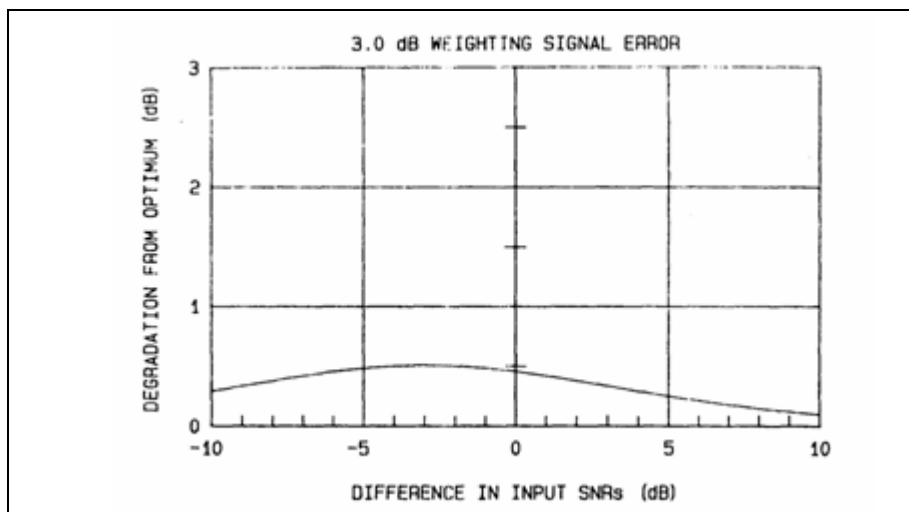

Figure 4-8. Combiner degradation from optimum with 3 dB weighting error.

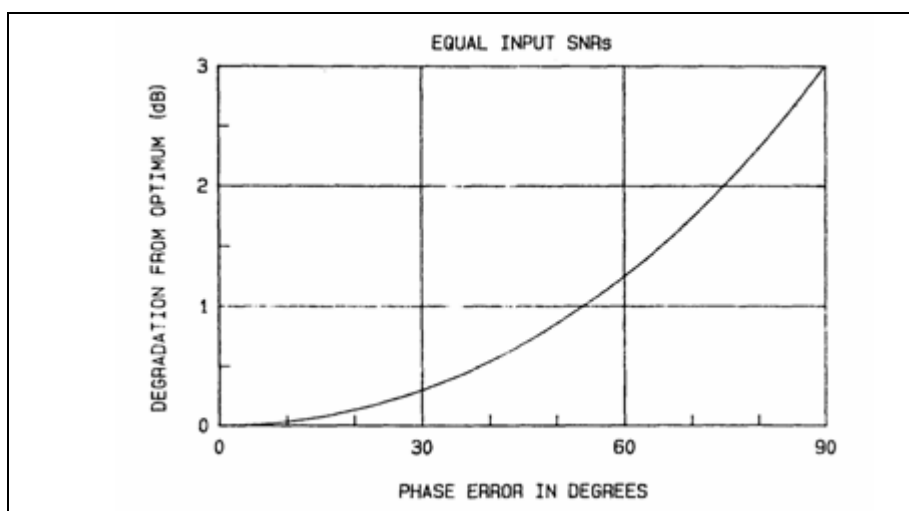

Figure 4-9. Combiner degradation from optimum versus phase error.

Percent coverage refers to the percentage of the sphere around the antenna where a certain gain is equaled or exceeded. The data in Table [4-1](#) shows that 50 percent of the time the combined output would be at least 3 dB better than a given channel. The data also shows that one percent of the time the improvement will be at least 9 dB. In other words, 99 percent of the time the improvement will be less than 9 dB. Another way of stating this is that if we want good data 99 percent of the time, the use of optimal ratio predetection combining versus using only one polarization (not selecting the best), can increase the link margin by 9 dB. Table [4-1](#) only includes effects because of transmitting antenna pattern polarization. The effects of multipath, ducting, and flame attenuation are not included in Table [4-1](#).

4.4.12 Diversity Combining of PCM/FM Signals. Predetection combining works well for PCM/FM signals as long as the combiner phase-lock loop (PLL) can properly align the IF signals. The major sources of PLL problems are

- a. Telemetry receivers in AFC mode with independent local oscillator, and
- b. The frequency difference between the IF signals may be too large for the phase-lock loop to attain lock

In short, AFC should not be used with predetection combining, and the receivers should be operated from a common local oscillator if possible.

Postdetection combining does not work as well as predetection combining for PCM/FM. The basic problem is that most of the bit errors in a near optimum PCM/FM system are caused by "pop" noise. An unfiltered pop has an area equal to one cycle. The area of an unfiltered PCM bit with peak deviation equal to 0.35 times the bit rate is 0.35 cycle. Therefore, the sum of two unfiltered bits is less than the amplitude of an unfiltered noise pop. The BER at the postdetection combined output is approximately equal to the BER of the best input channel so its performance is like that of a selector rather than an optimal ratio combiner.

4.4.13 Diversity Combining of PCM/PM Signals. Combining predetection and postdetection works well for PCM/PM with carrier tracking demodulators (as long as the demodulator is locked to the carrier). Predetection combining also works well for carrier reconstruction demodulators (Costas loop or squaring loop) as long as the demodulator is locked to the input signal. Postdetection combining cannot be used with carrier reconstruction demodulators unless an automatic polarity alignment circuit is added to the combiner to correct for the polarity uncertainty at the demodulator output. Without this circuit, the combiner could add two signals with opposite polarity and produce only noise at the output.

4.5 Magnetic Tape Recorders/Reproducers



This section relates to analog magnetic tape recording and may not be relevant to digital recording.

4.5.1 Introduction. The purpose of this section is to discuss the important functions of the recorder/reproducer system in storing telemetry data for other than real-time data processing operations. The characteristics of magnetic recording systems are discussed in Reference [4m](#) through Reference [4s](#).

4.5.1.1 Requirement to store telemetry data. The frequent requirement to store telemetry data occurs because of the following:

- a. Data rates may be too high to be processed in real-time
- b. Data is recorded at a remote receiving site and relayed to a central processing site
- c. Detailed post-flight analysis is required for certain portions of mission data
- d. There are shortages of data processing equipment or technical personnel
- e. There is a requirement to provide data for archival storage.

The performance functions to be discussed below include amplitude and phase response, noise power spectral density, intermodulation distortion, signal-to-noise ratio (SNR), harmonic distortion, cross-talk, and tape speed variation effects. Consideration is also given to FM, direct, predetection, and postdetection recording techniques, and the accepted head and tape handling practices. Within this document, it is assumed that all standard conditions, test methods, and measurement procedures of the most recent versions of IRIG documents 106 and 118 are adhered to in the selection of the recorder/reproducer system and in its alignment.

4.5.1.2 Considerations When Using a Recorder/Reproducer System in the Telemetry Link. A recap of terms in the IRIG Telemetry Standards is given below to alert operators to necessary considerations to be made when using a recorder/reproducer system in the telemetry link.

- a. Recorder/reproducer systems are classified by bandwidth. Intermediate bandwidth systems provide a maximum frequency response of 600 kHz at a tape speed of 60 IPS, wideband systems provide a maximum frequency response of 4.0 MHz at a tape speed of 240 IPS, and double density systems provide a maximum frequency response of 4.0 MHz at a tape speed of 120 IPS.
- b. Recording methods are classified by the method used to put the information signal onto the magnetic tape. Direct recording is accomplished by adding a high frequency bias signal to the information signal at the record head before storage on the magnetic tape. The FM recording is accomplished by applying an information signal to a subcarrier oscillator whose modulated output is applied to the record head. When using this method of recording, the high frequency bias signal may or may not be injected to the record head.

- c. Record/reproduce signal levels and input/output impedances are important requirements to maintaining expected system performance. The IRIG 106 document states the recorder input and output impedances for all three classes of systems shall be 75 ohms nominal at all frequencies in the passband. However, some installations prefer 50 ohm outputs. It is highly advisable to pay attention to these impedances, especially when using long coaxial cables carrying high frequency signals.
- d. Predetection recording (Pre-D) is the process of recording telemetry data signals prior to detection. In general, the practice involves heterodyning the output of the final IF in the receiver/combiner to a carrier frequency that falls within the passband of the recorder/reproducer system. The standard predetection carrier center frequencies vary from 112.5 to 2400 kHz. The heterodyned center frequency containing the data multiplex may then be "direct" recorded on the recorder/reproducer system. The purpose of recording the transmitted telemetry data multiplex in this manner is that it allows the opportunity to select optimum characteristics for the type of detector, signal conditioners, and other data processing equipments to provide the highest quality data in other than real-time operations.
- e. Postdetection (Post-D) recording is the process of recording received telemetry data signals after "detection" in the receiver system. It involves the recording of the raw telemetry signal before or after signal conditioning, including bit synchronization, and recording is done in the FM or direct record modes of operation; thus eliminating the need for heterodyning as in the Pre-D recording process. FM recording is used when a dc or very low frequency needs to be recorded and reproduced accurately. Postdetection direct recording is used with signals, which do not have important information at frequencies below the reproduce system low frequency cutoff.

4.5.2 Head Segment Gap Azimuth. Head segment gap azimuth is defined in IRIG 106 (Telemetry Standards) as the angle formed in the plane of the tape between a line perpendicular to the head reference plane and a line parallel to the trailing edge of the record head segment gap or parallel to the center line of the reproduce head segment gap. The azimuth should always be peaked on the prime data track that is being played back. All tracks are supposed to be within 2 dB of each other but may not be. The problem that misadjusted azimuth creates is shown in Figure 4-10. The reproduce gap segment was modeled as four separate segments (slanted line crossing the four signals). The output signal is the sum of the signals in each segment. As the frequency increases, the phase differences along the gap increase. This causes the output signal to decrease in amplitude. The azimuth loss can be calculated using

$$\text{azimuth loss} = 20 \log ((\sin x)/x) \quad (4-9)$$

where

$$\begin{aligned} x &= (\pi w \tan \alpha)/\lambda \quad (\text{radians}) \\ w &= \text{width of recorded track} \\ \alpha &= (\text{angle of misalignment}) \\ \lambda &= \text{wavelength of recorded signal.} \end{aligned}$$

Assume that the track width is 50 mils, the angle of misalignment is 1 minute of arc, and the wavelength is 60 microinches, an azimuth loss of 0.85 dB is calculated. Increase the angle of misalignment to 2 minutes of arc, the azimuth loss is now 3.6 dB. Now decrease the wavelength to 30 microinches (double density recording) and the azimuth loss will be 29.3 dB. This loss can be decreased to 3.6 dB by decreasing the track width to 25 mils. The azimuth loss is a function of the product of the track width in inches and the azimuth error in radians divided by the wavelength in inches. When this term is approximately equal to 1.39, the azimuth loss is 3 dB. When this term is approximately 0.82, the azimuth loss is 1 dB. The azimuth loss for a 50 mil track width with 2 and 4 minutes of azimuth error is plotted in Figure [4-11](#) as a function of frequency.

Azimuth alignment between reproduce head and the signal recorded on tape is extremely important in achieving full system response and in establishing cross play capability between different systems. Optimum frequency response and system-to-system compatibility can only be achieved when these alignments are maintained in accordance with the IRIG Telemetry Standards and monitored diligently. Misalignment of azimuth can significantly degrade system frequency response and subsequently data quality. A common practice is to align the reproduce head azimuth to produce the highest amplitude, of an upper band edge signal, at the reproducer output. Some recorder/reproducer systems also have azimuth adjustable record heads, so great caution must be exercised when adjusting the azimuth of the record heads so as not to destroy the alignment compatibility between different recorder/reproducer systems.

The correct azimuth alignment of the record head is a very important requirement to achieving system-to-system compatibility. Many recorder/reproducer manufacturers provide precision fixed mounting plates for the record heads; they do not include an adjustment for azimuth alignment by station operators. However, some systems do have external azimuth alignment adjustments accessible to station operators. Great caution must be exercised with those systems having external record head azimuth adjustments or system-to-system compatibility can and will be degraded or destroyed. The procedure to follow for correctly adjusting the azimuth alignment in systems with adjustable record head involves the use of a "standard" pre-recorded magnetic tape that contains record head azimuth adjustment signal information. The procedure, therefore, references all record head azimuth alignments to a standard recorder/reproducer system. The pre-recorded tape is reproduced on the system in question, and the reproduce head azimuth is adjusted to produce the desired output from the pre-recorded tape. After having carefully adjusted the reproduce head azimuth, an upper band edge signal is recorded and reproduced in realtime. The record head is then adjusted in realtime to produce the peak output amplitude of the upper band edge signal at the reproducer system output. It is highly advisable, because of the importance of this adjustment, to input a swept frequency signal to the system, record and reproduce it in realtime, and observe the output of the reproducer system for the desired continuous sweep frequency signal. Nodes of reduced amplitude in the reproduced sweep signal indicate that the azimuth adjustment has been done incorrectly and therefore, the procedure should be repeated. The correct record head azimuth adjustment is an assurance that system-to-system compatibility will not be degraded because of misalignment of this parameter.

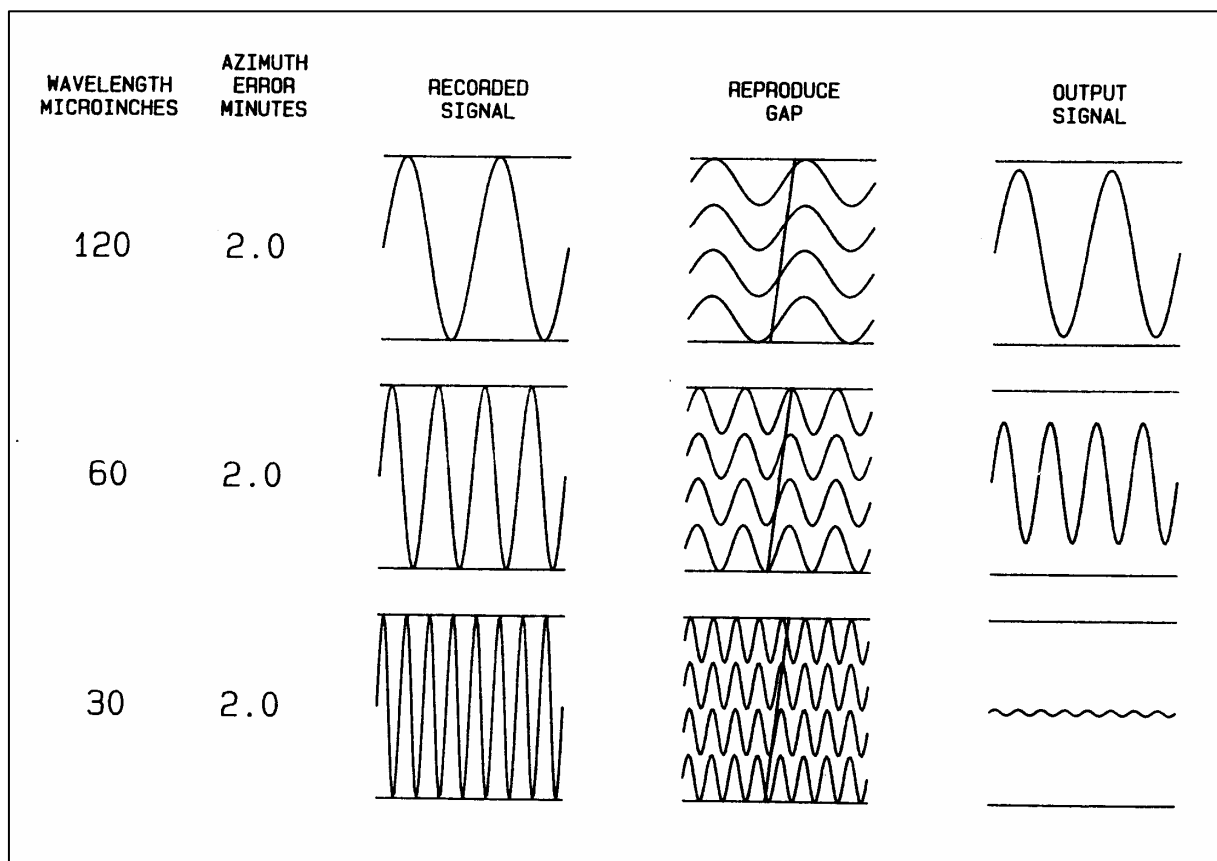

Figure 4-10. Azimuth error illustration.

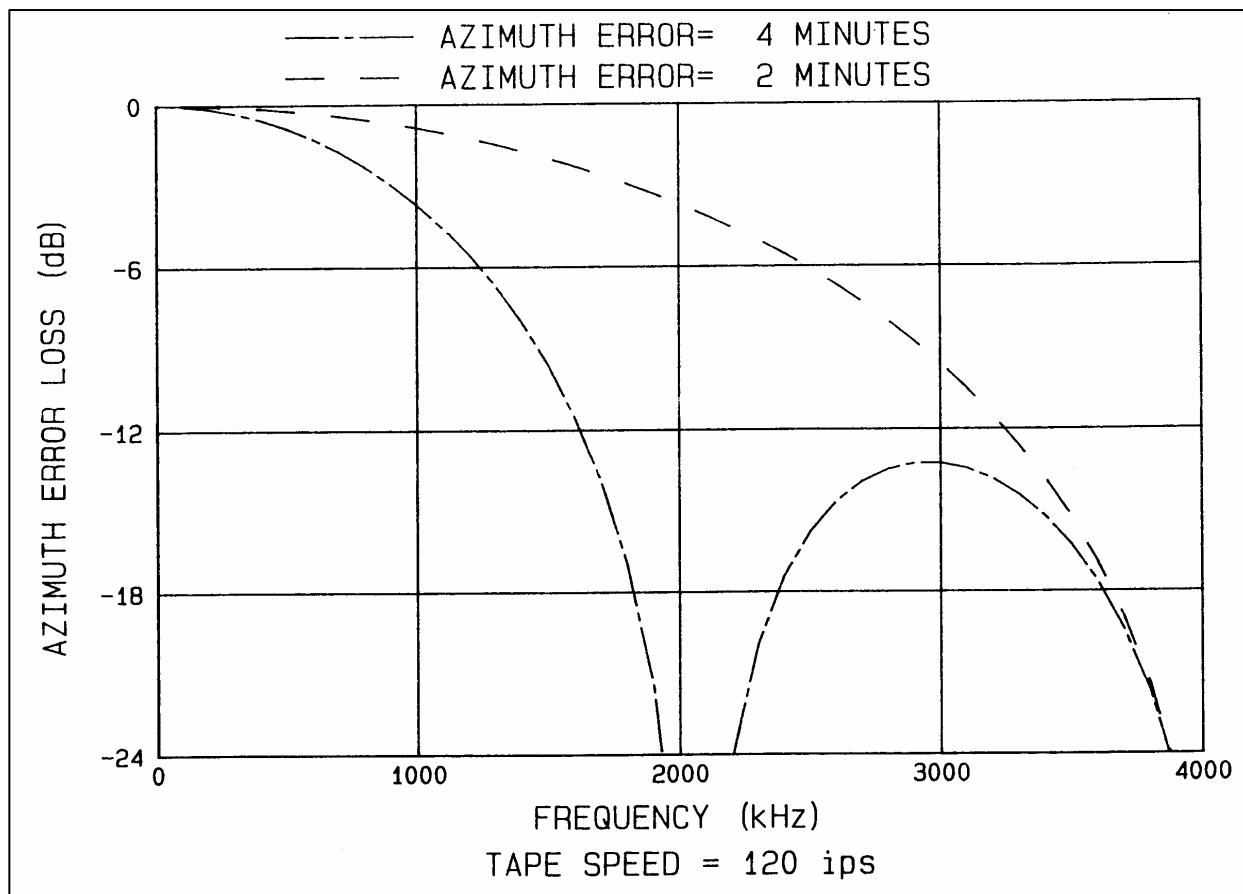

Figure 4-11. Azimuth error loss versus frequency (120 ips).

4.5.3 Spacing Loss. Spacing loss is caused by the effective spacing between the magnetic head and the magnetic particles in the tape. The following formula for spacing (or separation) loss was developed by Wallace (Reference 4t) in 1951:

$$\text{spacing loss} = e^{-2\pi d/\lambda} \quad (4-10)$$

$$\text{spacing loss (dB)} = 20 \log_{10} e^{-2\pi d/\lambda} \quad (4-11)$$

$$\text{spacing loss (dB)} = 54.6 d/\lambda \text{ dB}, \quad (4-12)$$

where

d = effective spacing between reproduce head and magnetic medium

λ = recorded wavelength.

If a 1 MHz sine wave is recorded at a tape speed of 60 inches per second and the effective head-to-tape separation is 18 microinches, the spacing loss will be

$$54.6 (18 \times 10^{-6} / 60 \times 10^{-6}) = 16.4 \text{ dB}.$$

As a result, the spacing loss significantly lowers the slot SNR at short wavelengths. The effective spacing is a function of the physical spacing, tape roughness, and head gap lengths for recording and reproducing. Debris on the tape can decrease short wavelength signals to obscurity.

4.5.4 Reproduce Gap Loss. The reproduce gap loss is caused by the finite length of the reproduce gap as illustrated in Figure 4-12. The output signal is the average of the signals within the gap. When the recorded wavelength is equal to the effective gap length, the average flux across the gap is zero, and therefore the induced voltage is zero. The formula for reproduce gap loss is

$$\text{gap loss} = (\sin x)/x \quad (4-13)$$

or

$$\text{gap loss (dB)} = 20 \log ((\sin x)/x) ,$$

where

x is equal to $\pi\ell/\lambda$

λ is the recorded wavelength

ℓ is the effective reproduce gap length

The reproduce gap loss as a function of frequency is plotted in Figure 4-13 for reproduce gap lengths of 12 and 28 microinches. The loss because of a 28 microinch reproduce gap length at a wavelength of 60 microinches is 3.4 dB; the loss at a wavelength of 120 microinches is 0.8 dB.

4.5.5 Bias Recording. The purpose of recording with a bias signal is to overcome the inherent non-linearity of the record and reproduce processes (see Figure 4-14). The input is along the B_r axis and the output is along the H axis in Figure 4-14. If a small signal (solid line) is recorded, the output amplitude is small; if a large signal (dashed line) is recorded, the distortion is severe. Some of these problems can be overcome by using dc-bias as shown in Figure 4-15. However, the SNR is still poor and the heads tend to become magnetized. Wideband instrumentation recorders typically sum an ac-bias signal with the signal to be recorded. The frequency of this bias signal should be at least 3.5 times the highest frequency signal to be recorded. The effect of the ac-bias signal is to increase the SNR and reduce the distortion as illustrated in Figure 4-16. The normal bias current setting is 2 dB overbias (upper band edge signal output amplitude reduced by 2 dB from maximum). The effects of under- and over-bias are illustrated in Figure 4-17. If linearity is not important, the SNR may be improved by the use of saturation recording instead of ac-bias recording.

4.5.6 Equalization. The purpose of equalization is to correct for the amplitude and phase transfer functions of the recording and reproducing processes. A separate equalizer is used for each playback speed. The amplitude equalizer must boost the low and high frequency components. A sample signal response curve at the input to the equalizer is shown in Figure 4-18. The output of the equalizer is shown in Figure 4-19. The equalizer has made the frequency response nearly constant from near dc to almost 500 kHz.

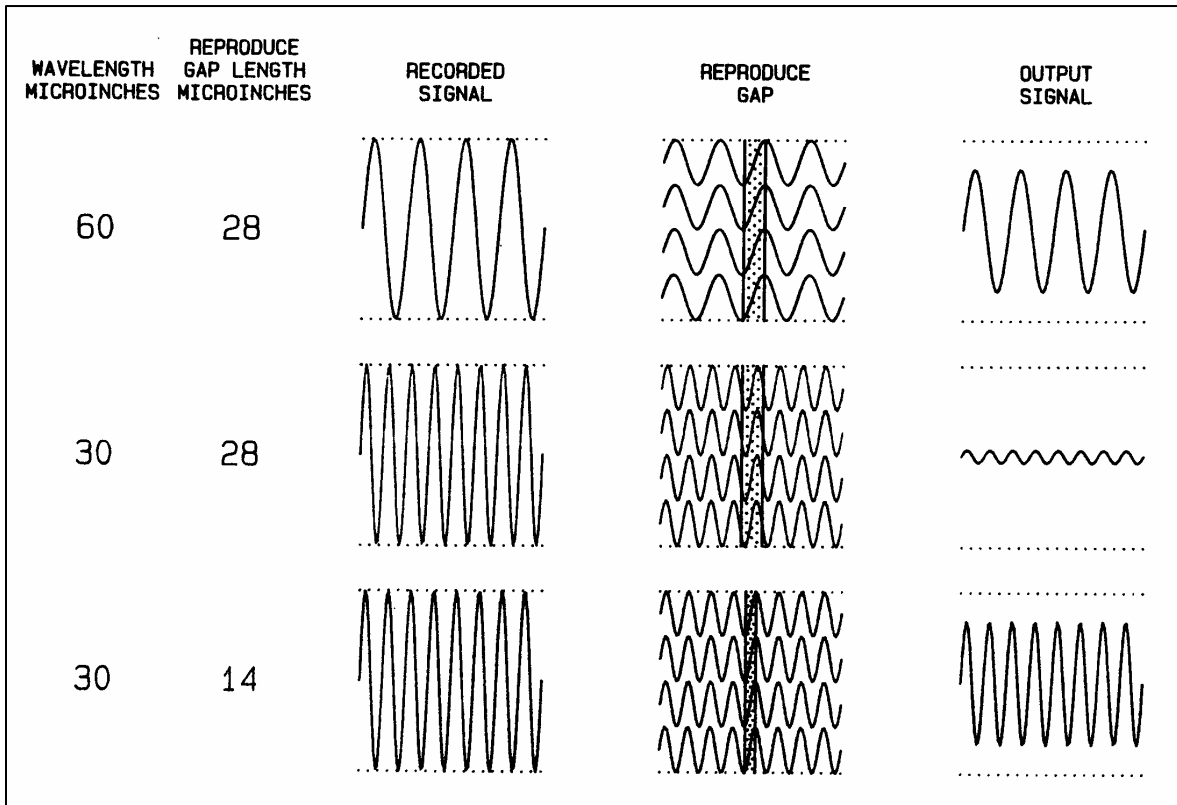

Figure 4-12. Reproduce gap loss illustration.

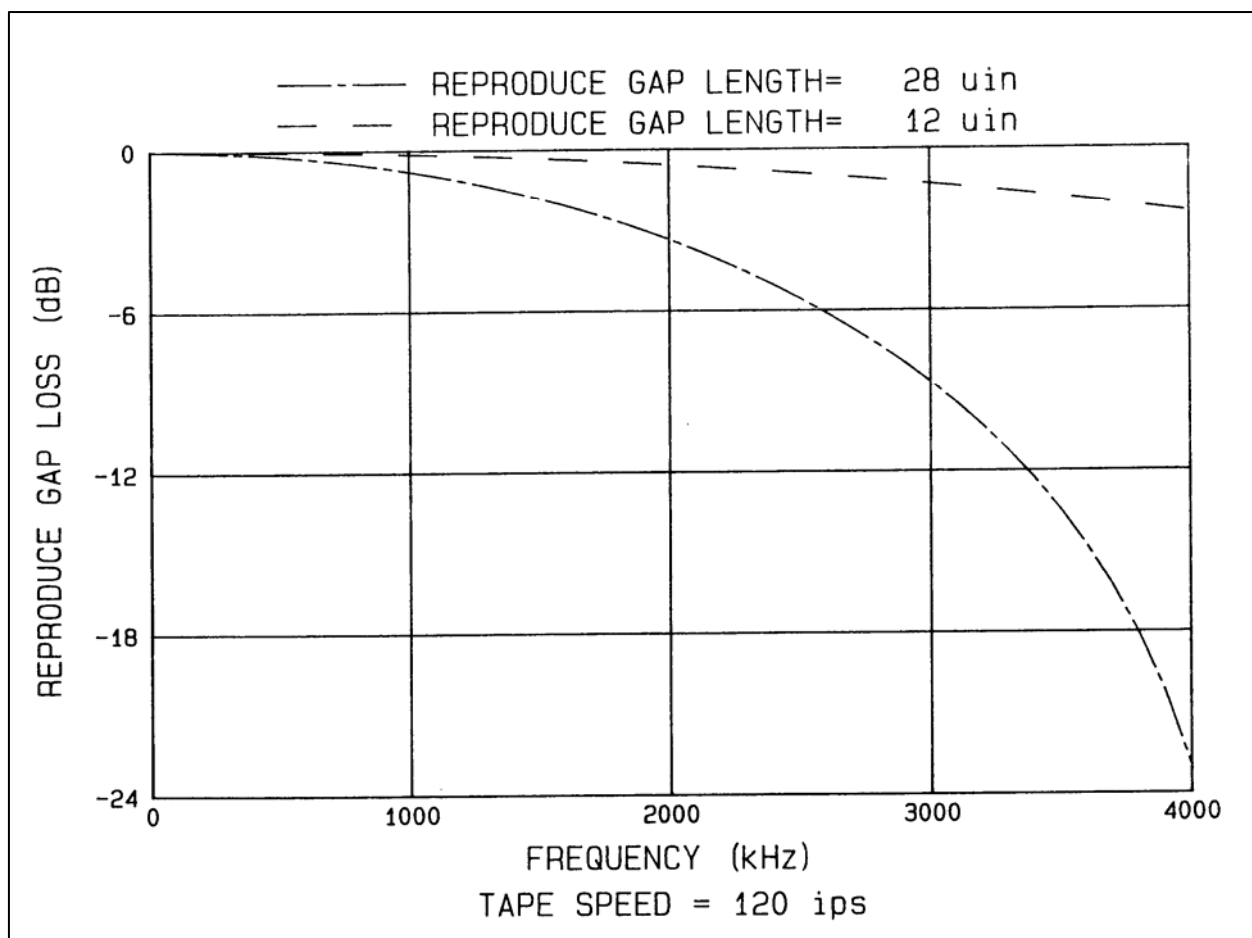

Figure 4-13. Reproduce gap loss versus frequency.

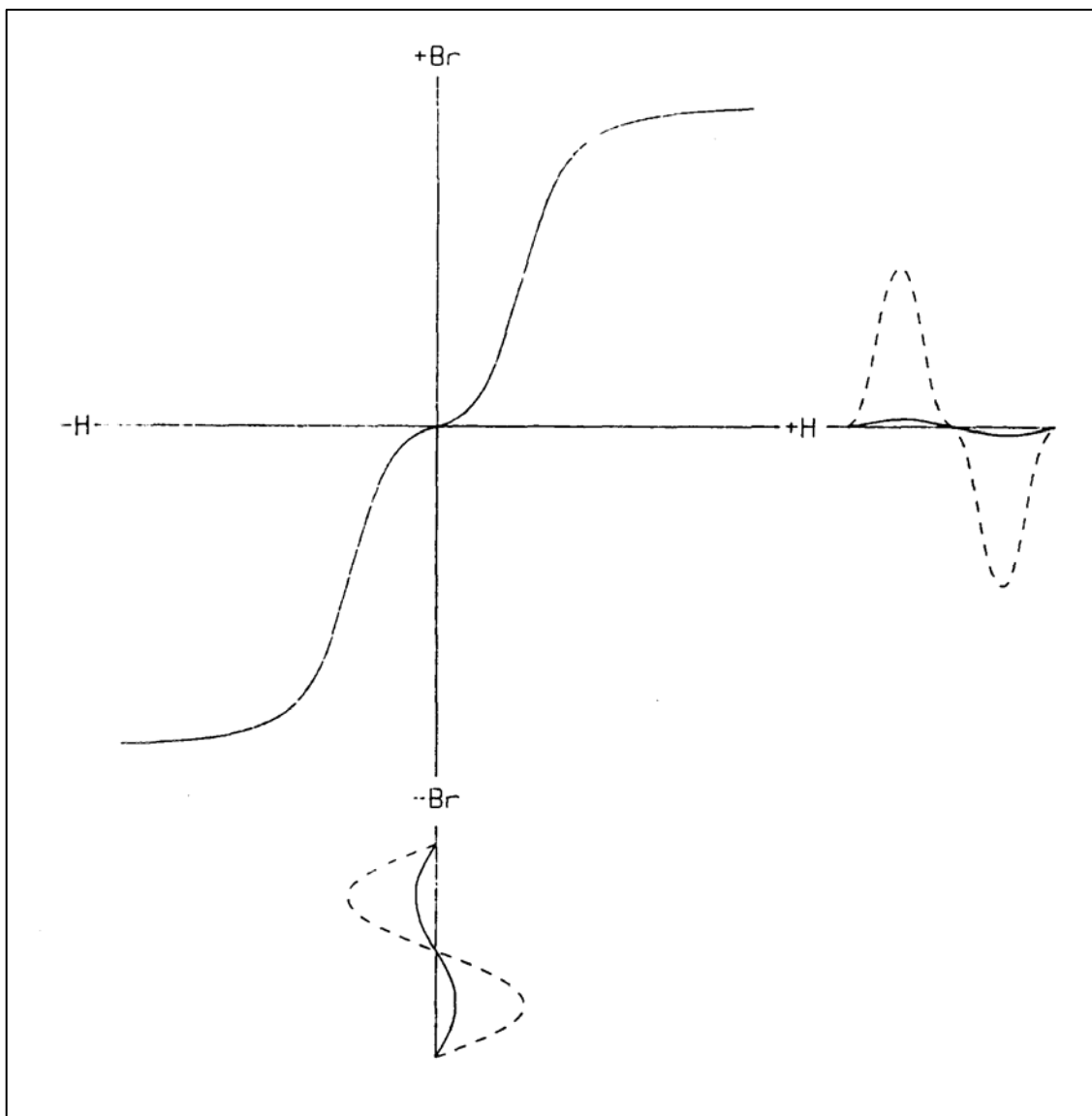

Figure 4-14. Recording without bias.

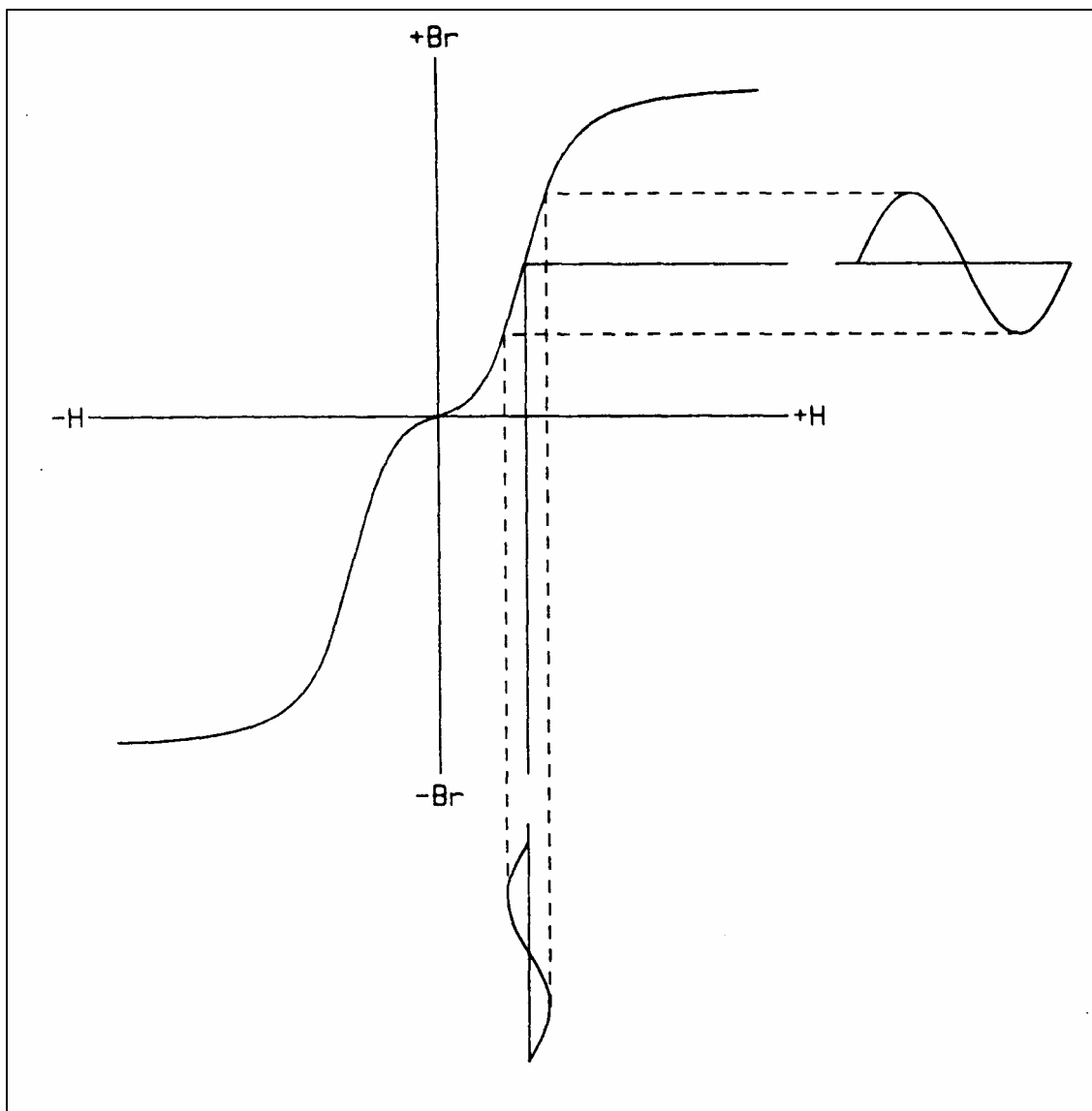

Figure 4-15. Recording with dc-bias.

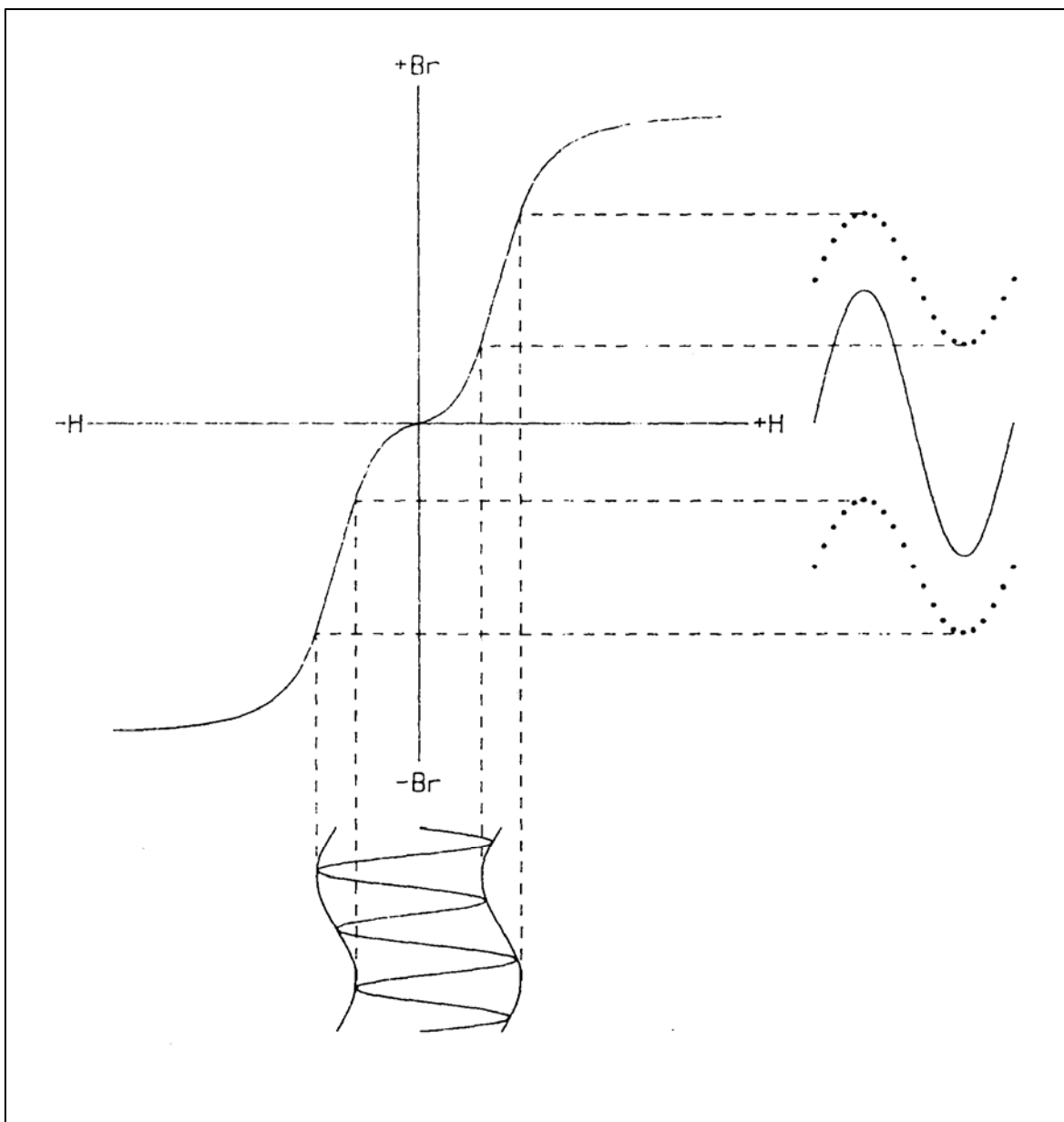

Figure 4-16. Recording with ac-bias.

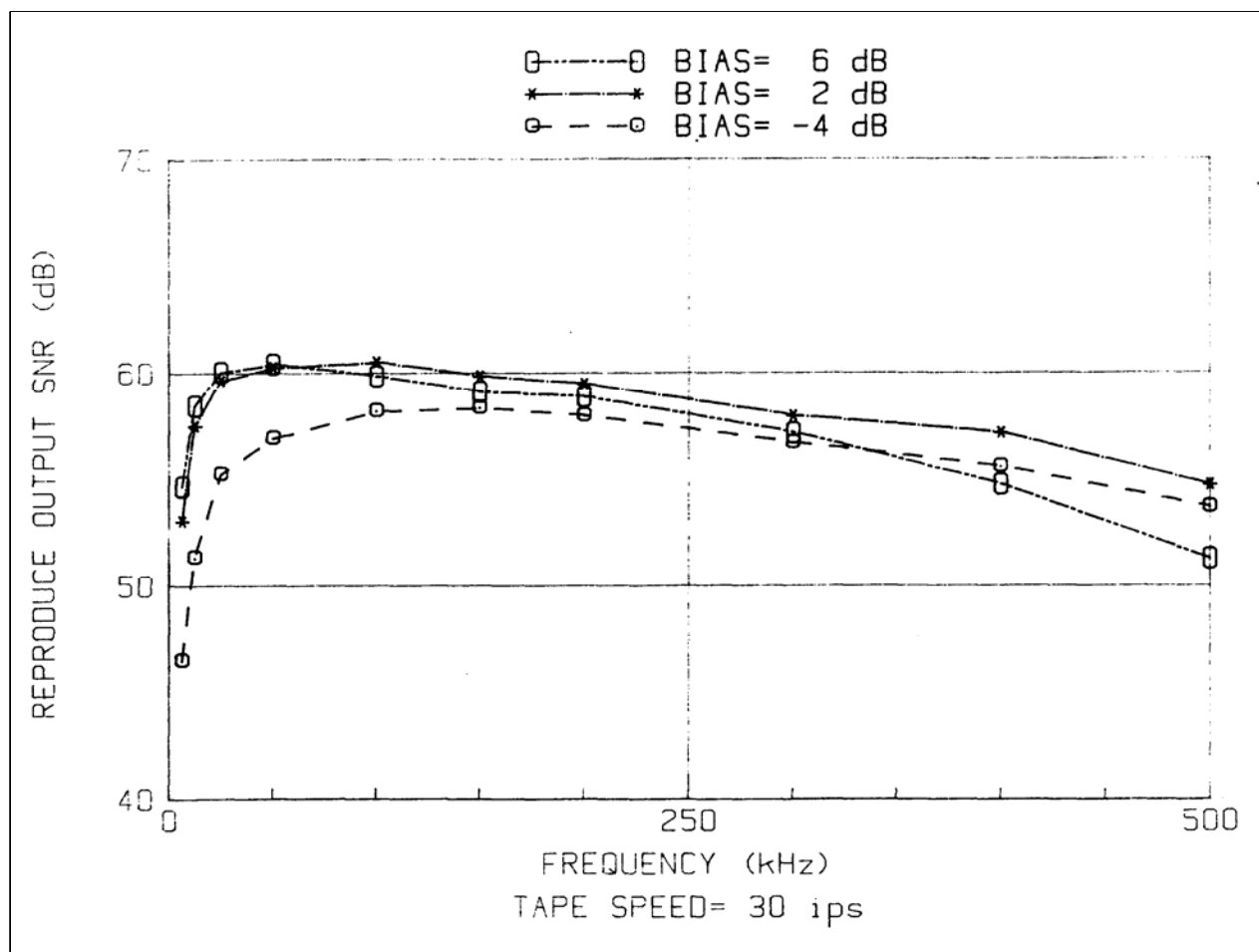

Figure 4-17. Effects of over-bias and under-bias recording (input level constant).

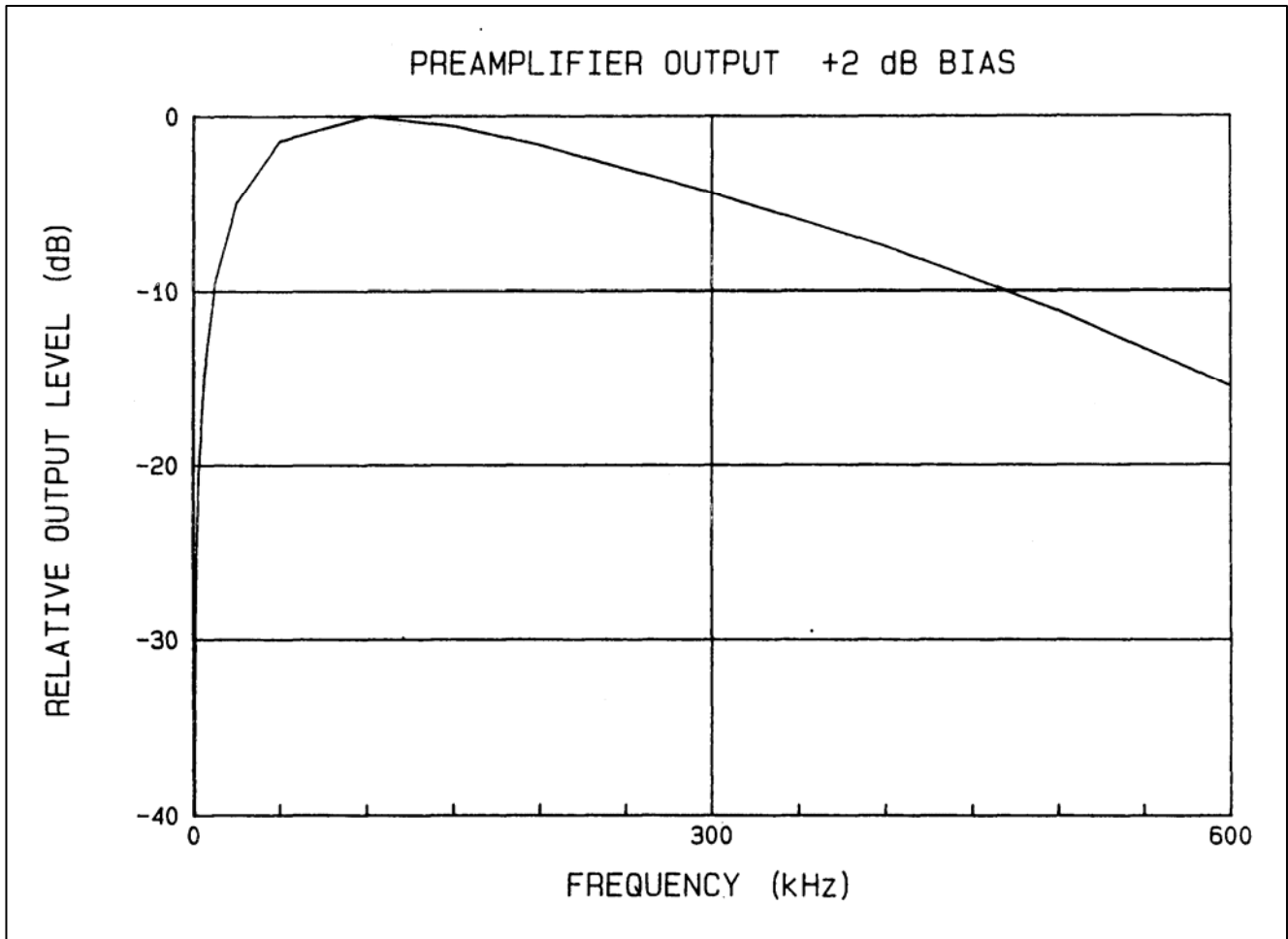

Figure 4-18. Equalizer Input at 30 IPS.

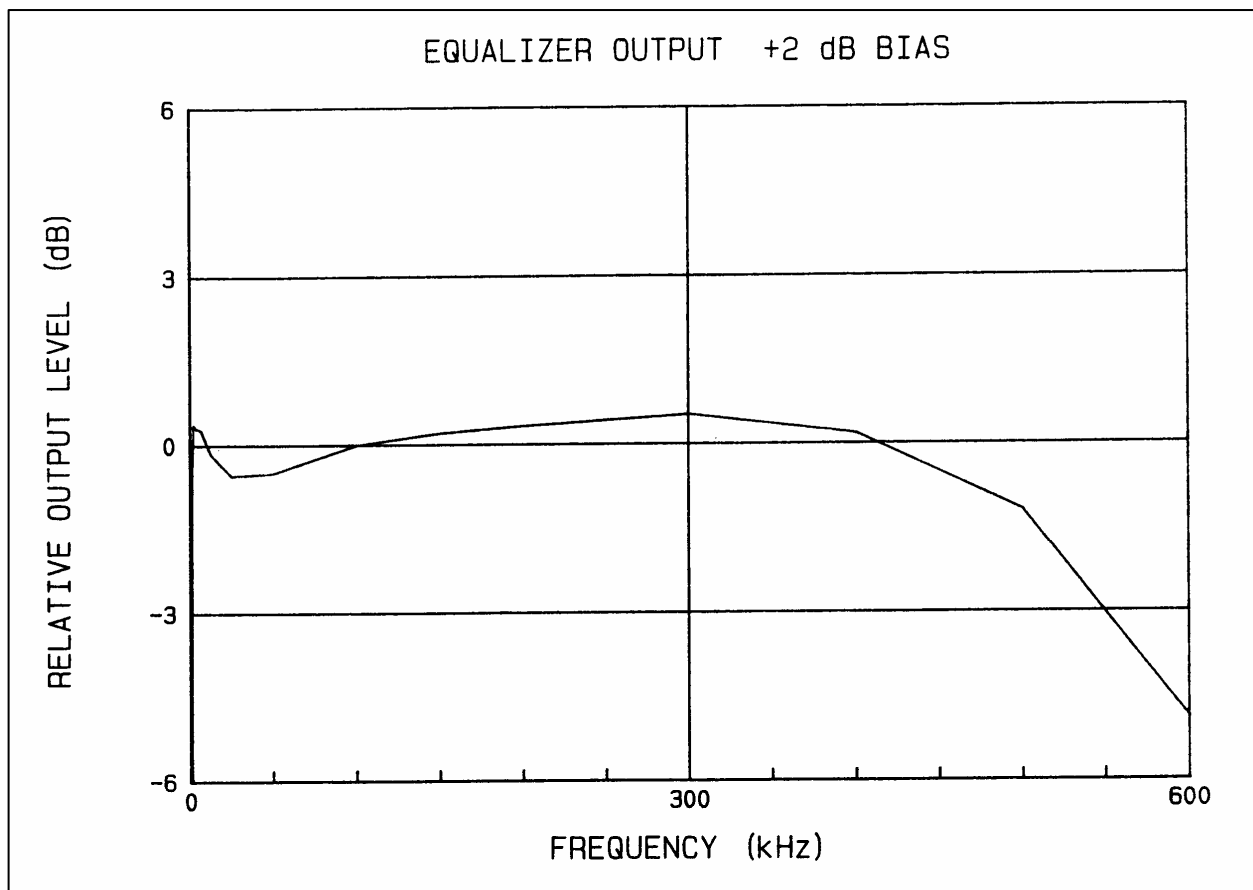

Figure 4-19. Reproducer output at 30 IPS.

4.5.7 Reproducer Output SNR. The wideband SNR (dB) (direct recording) at the output of a properly aligned record/reproduce system varies from the low 20s to the mid 30s at tape speeds above 15 ips. The SNR (dB) in a 3 kHz bandwidth with a wideband direct system at a tape speed of 120 ips and a frequency of 400 kHz can exceed 70 dB in a well-aligned system. The SNR is lower at other frequencies. These SNRs are more than adequate for most telemetry applications. The SNR is degraded by tape copying (dubbing). The biggest sources of SNR problems seem to be improper record and bias levels, undetected equipment problems, material build-up on the heads, and improper azimuth alignment. Tape dropouts also degrade the SNR for short times.

4.5.8 Predetection Recording. As discussed earlier, there are several methods for recording telemetry signals. These methods are illustrated in Figure 4-20. This subsection will only discuss predetection recording. Typical performance data will be presented with a tape recorder/reproducer and with the recorder bypassed. Demodulation at the tape carrier frequency and after upconversion to a higher frequency (typically 10 or 20 MHz) will be included in this discussion. The data in this subsection are for PCM signals. Predetection recording is also frequently used for PAM signals.

Figure 4-21 shows that the BER performance of 300 kb/s NRZ-L PCM/FM is the same with either a 450 or a 900-kHz predetection carrier frequency. The BER performance of the predetection signals with 500 kHz receiver and playback IF bandwidths was approximately 1 dB better than the BER performance of direct receiver video with a 500-kHz IF bandwidth. The reason is that putting two 500-kHz bandwidth filters in series results in a filter with a bandwidth of approximately 400 kHz, which increases the actual IF SNR by 1 dB and therefore improves the BER by approximately 1 dB. An entry of "0" in the legend for the figures in this subsection means that part of the test setup was not used for this data; for example, no recorder was used for the data in Figure 4-21. The data presented in Figure 4-22 show the effects of receiver IF bandwidth and tape recording on BER performance. The degradation because of widening the receiver IF bandwidth at a 10^{-4} BER was approximately 1.1 and 2.3 dB for the 2.4 and 4.0 MHz bandwidths. The recorder/reproducer caused a degradation of no more than 0.3 dB. Figure 4-23 shows the effect of varying the receiver IF bandwidth at a bit rate of 900 kb/s and a predetection frequency of 900 kHz. The BERs with the 1000- and 1500-kHz bandwidths were very similar, while the 2400-kHz bandwidth caused approximately 0.5 dB of degradation and the 4000-kHz bandwidth caused approximately 1.8 dB of degradation at a BER of 10^{-4} . The degradation with the 4000-kHz IF bandwidth is mostly caused by noise folding back across 0 Hz and increasing the noise power in the playback demodulator's passband. This is illustrated in Figure 4-24. The higher amplitude trace in each group is the noise with a 3000-kHz IF bandwidth and the lower amplitude trace is the noise with a 1500-kHz IF bandwidth. The noise power is the same with both filters for frequencies between 9.6 and 10.4 MHz and 900 and 1300 kHz. However, the 3000-kHz IF bandwidth causes the noise power between 500 and 800 kHz to increase by 1 to 2 dB. The predetection downconverter also does some low-pass filtering. The unmodulated carrier level was 0 dBc for these plots. Figure 4-25 shows that using a 900-kHz predetection carrier with 900 kb/s NRZ-L PCM/FM data causes a data degradation of approximately 0.2 dB at a 10^{-4} BER when compared to the BER performance using a 1.8-MHz predetection carrier frequency. This slight degradation may well be preferable to doubling the tape speed so that the 1.8-MHz predetection carrier could be used.

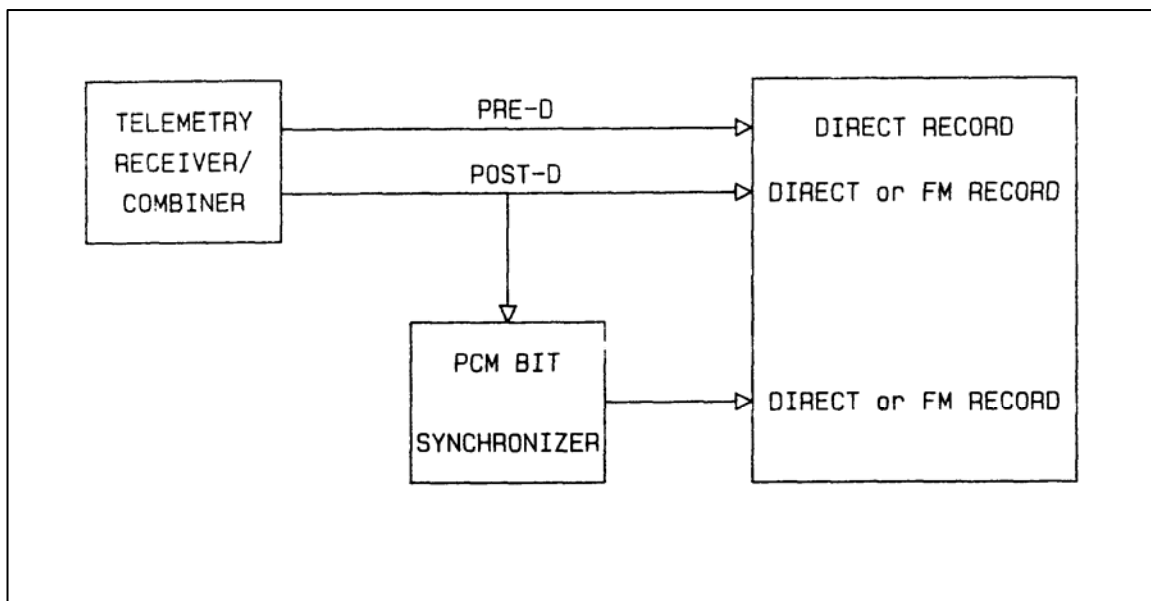

Figure 4-20. Methods for recording telemetry signals.

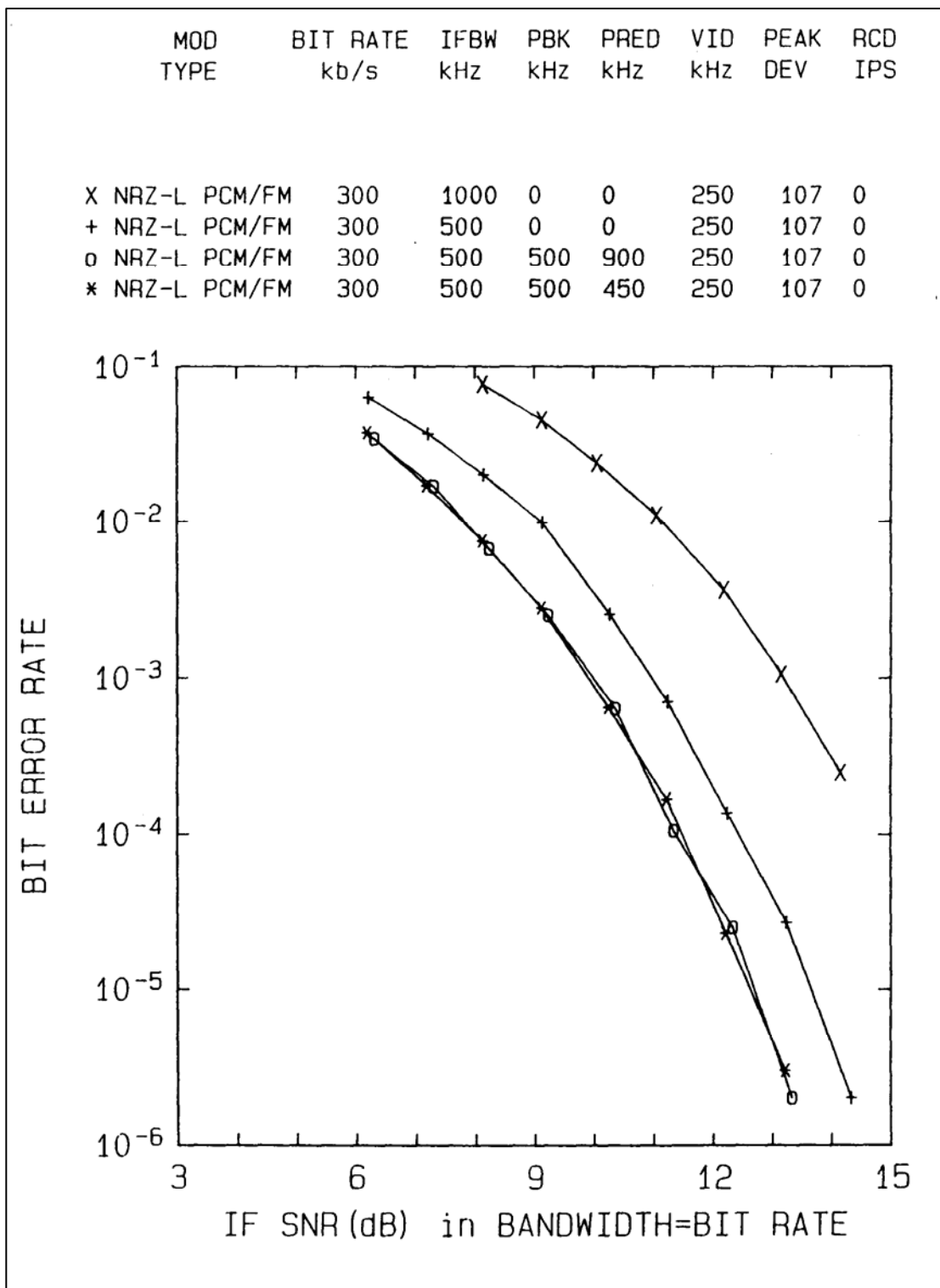

Figure 4-21. BER with 300 kb/s and 450 and 90 kHz PRE-D.

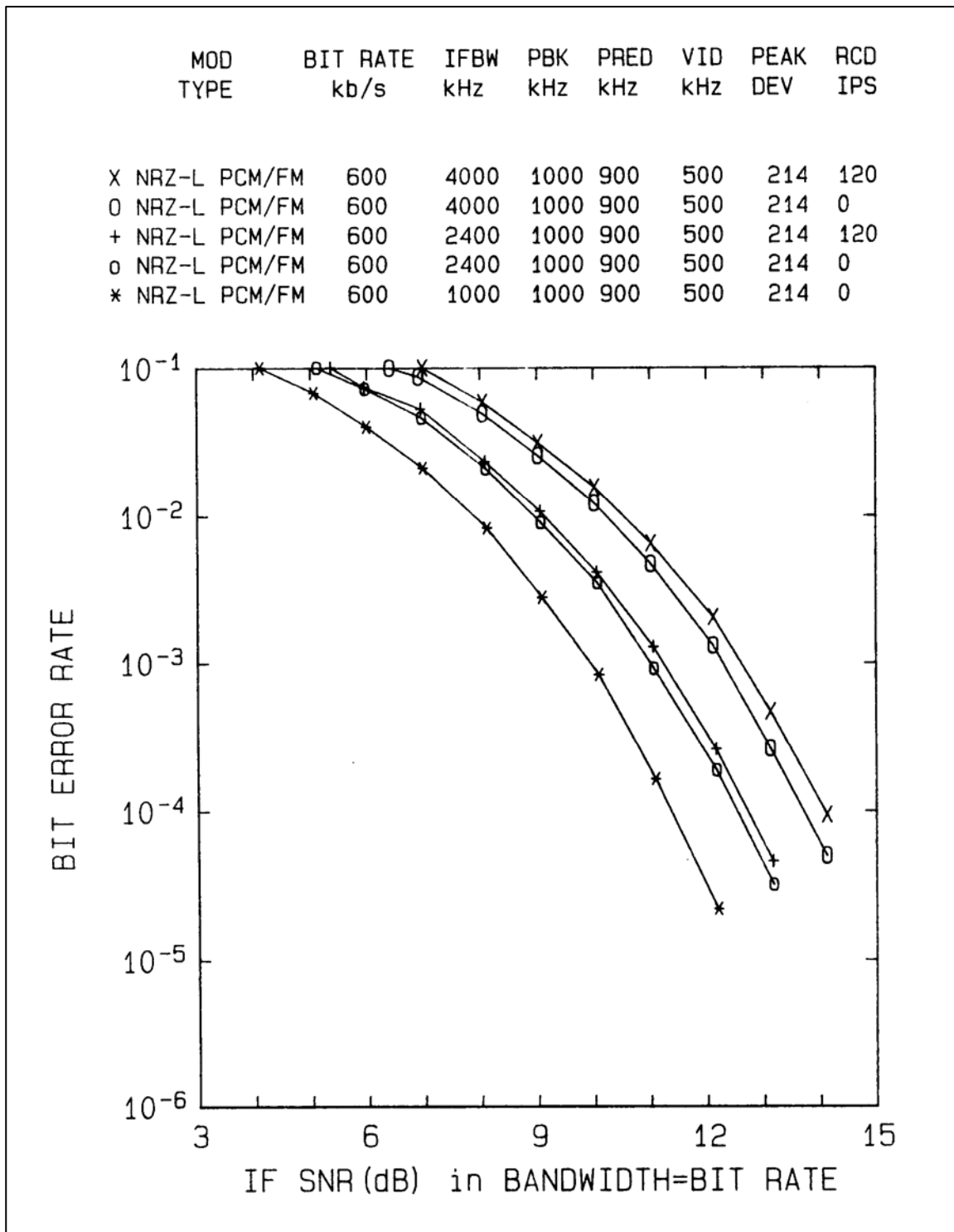
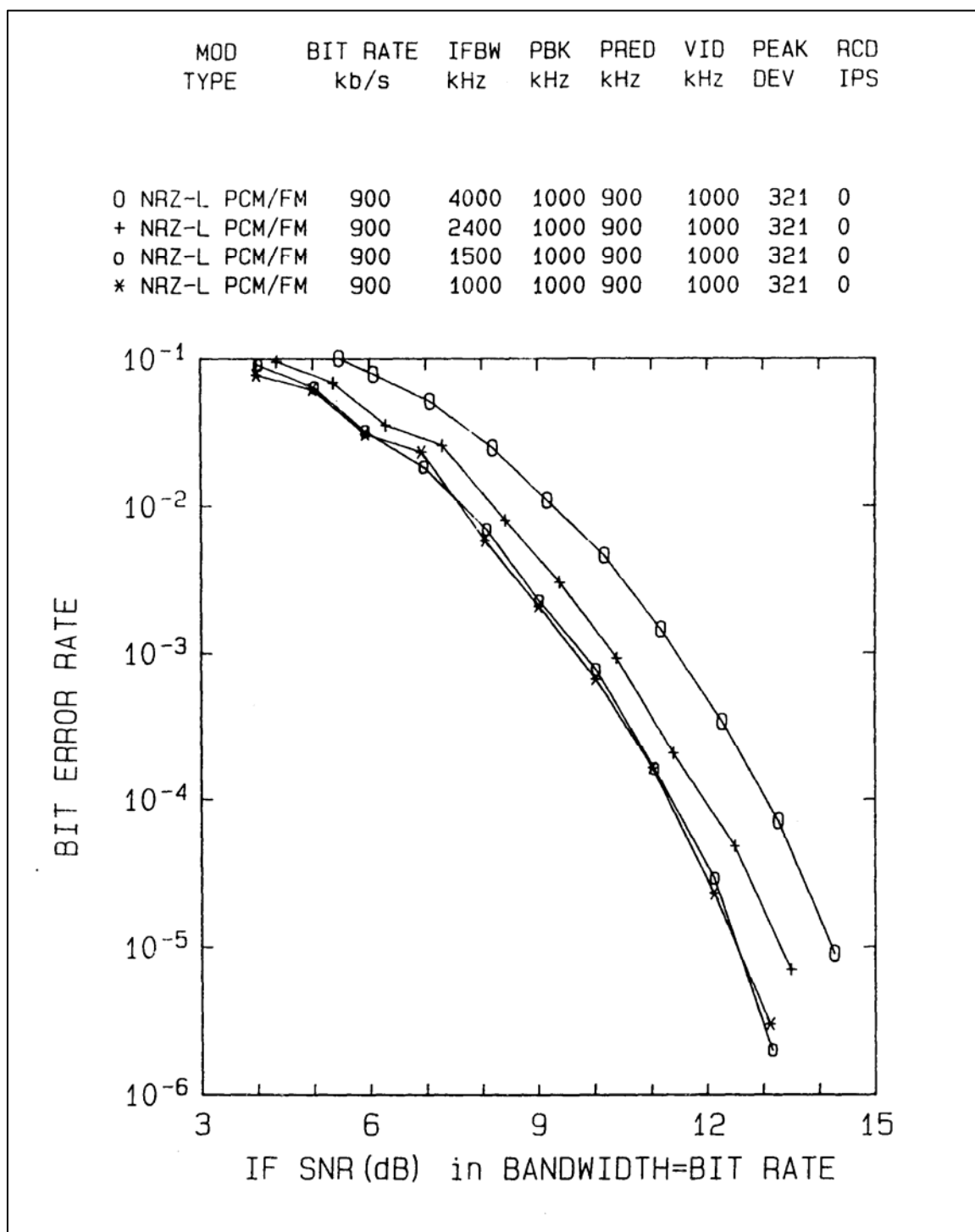

Figure 4-22. BER with and without recording.



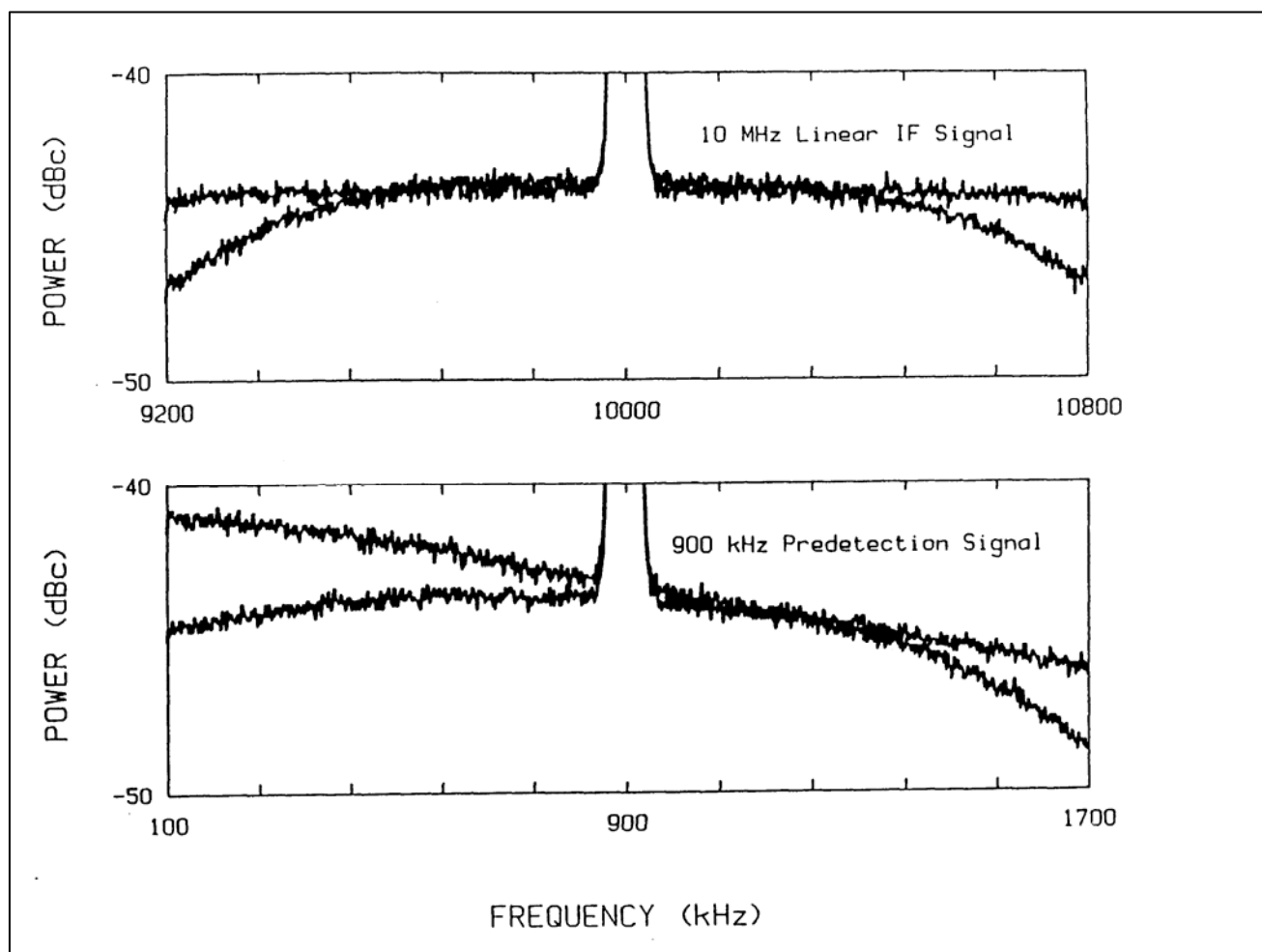

Figure 4-24. Noise PSDs for IF and PRE-D signals.

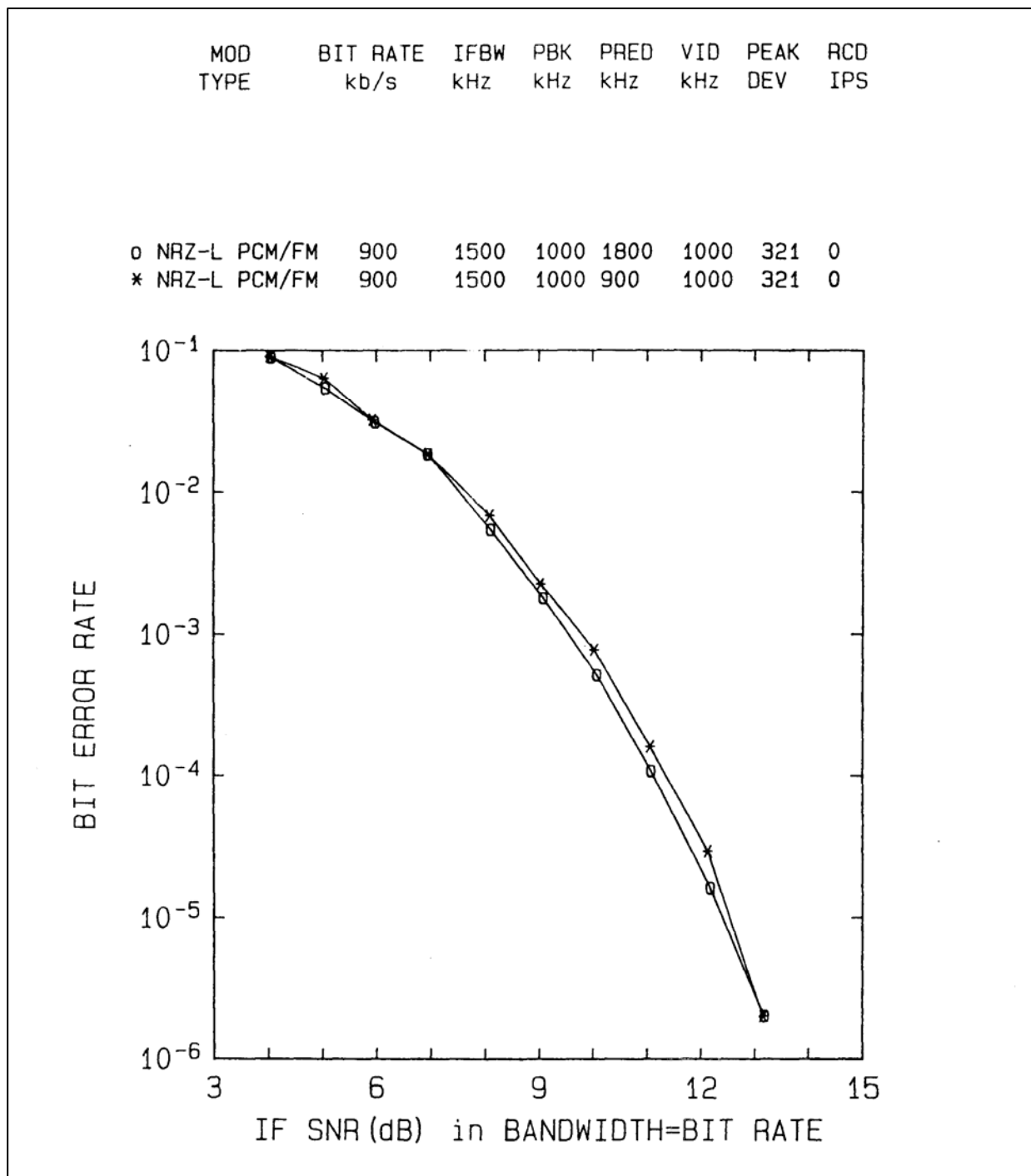

Figure 4-25. BER for 900 kb/s with 900 and 1800 kHz PRE-D.

The data in Figure 4-26 show that upconversion and demodulation perform approximately 1.6 dB better than demodulation at the tape carrier frequency when the NRZ PCM/FM bit rate is equal to the predetection carrier frequency. Most of the degradation is due to excessive bandpass filtering in the tape carrier discriminator. The bandwidth is only 720 kHz (900 \times 40 percent) which degrades the BER by more than 1 dB.

The data in Figure 4-27 shows that a 1200-kHz predetection carrier performs 2 to 3 dB better than a 900-kHz carrier for 1200 kb/s NRZ-M PCM/PM (90³). Figure 4-28 presents data for biphas-level PCM/PM (75³) for demodulation at 900 kHz and at 10 MHz (PRED = 0). Demodulation at 900 kHz degrades the 300-kb/s performance by 0.3 dB and the 600-kb/s performance by 1 dB at a 10⁻⁴ BER. The difference in BER performance at a 10⁻⁴ BER between 300 and 450 kb/s is approximately 0.5 dB, while the difference between 300 and 600 kb/s is approximately 1.8 dB. This suggests that the highest recommended biphas bit rate should be one-half of the predetection frequency.

4.5.9 Serial High Density Digital Recording (HDDR). Serial HDDR is a method of recording digital data on a magnetic tape where the digital data is applied to one track of the recording system as a bi-level signal (Reference 4u and Reference 4v) . Reference 4v also includes discussions of parallel HDDR and error correction codes for magnetic recording. The codes recommended for serial HDDR recording of telemetry data are biphas-level and randomized NRZ-L (RNRZ-L). The maximum recommended bit packing densities for reliable data interchange are 0.9 bits/Hz for biphas-level and 1.5 bits/Hz for RNRZ-L

The properties of the biphas-level and RNRZ-L codes relevant to serial HDDR and the methods for generating and decoding RNRZ-L are described below. Recording with bias is required for interchange applications because reproduce amplifier phase and amplitude equalization adjustments for tapes recorded without bias usually differ from those required for tapes recorded with bias.

The biphas-level and RNRZ-L codes were selected for this standard because the "level" versions are easier to generate and are usually available as outputs from bit synchronizers. "Mark" and "Space" codes also have about twice as many errors as the level codes for the same SNR. If polarity insensitivity is a major consideration, agreement between interchange parties should be obtained before these codes are used.

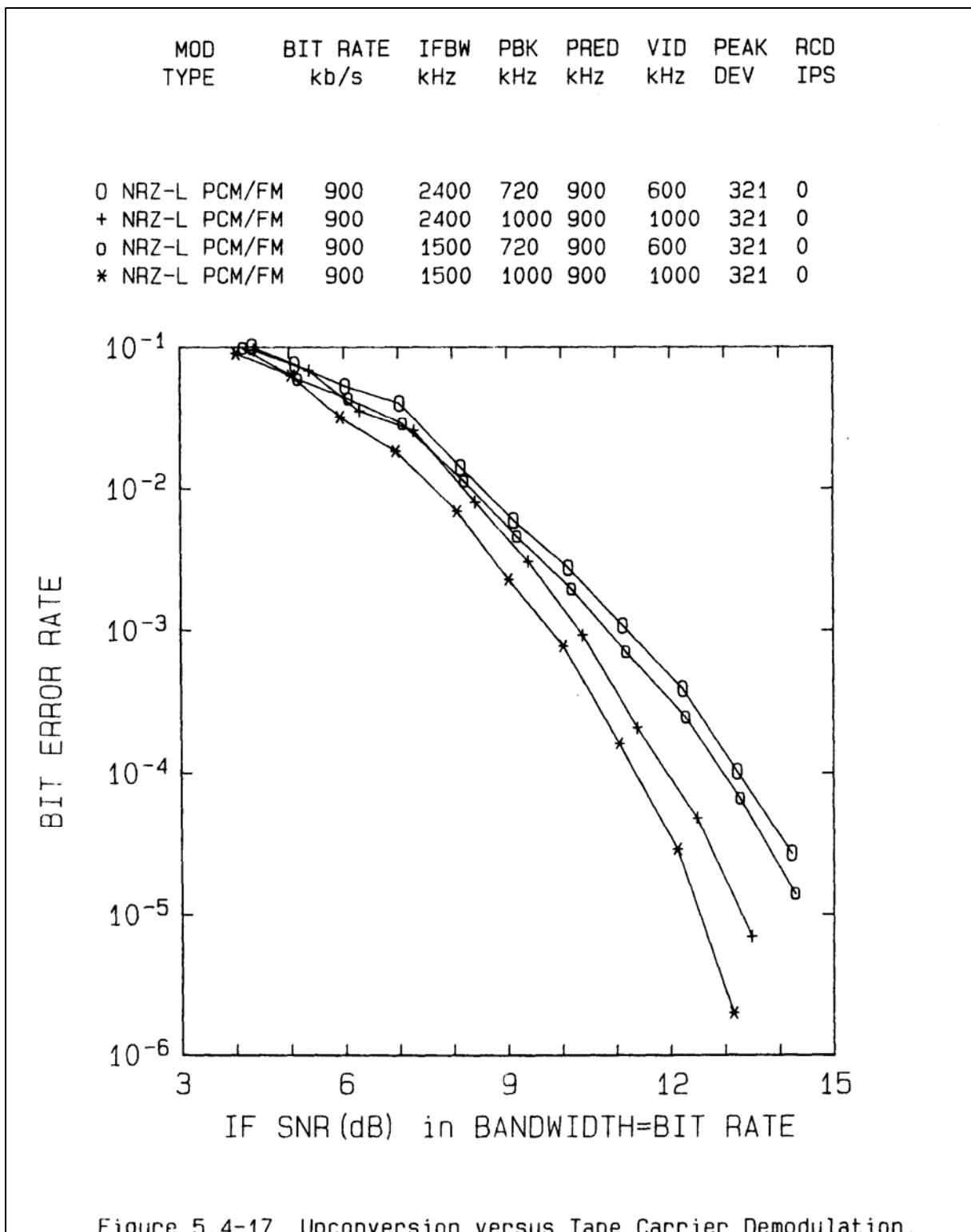

Figure 4-26. Upconversion versus tape carrier demodulation.

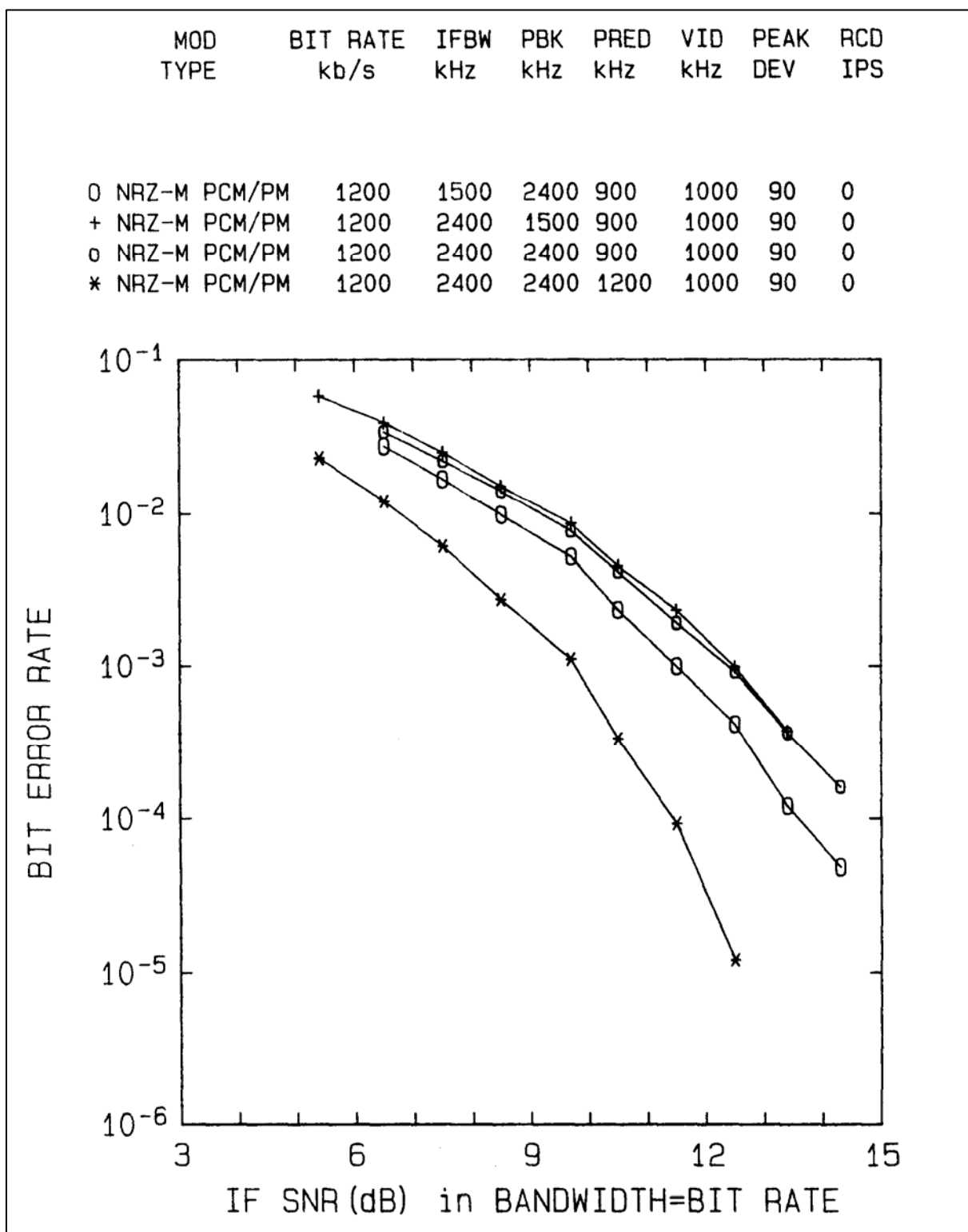

Figure 4-27. BER for 1200 kb/s PCM/PM with 900 and 1200 kHz PRE-D.

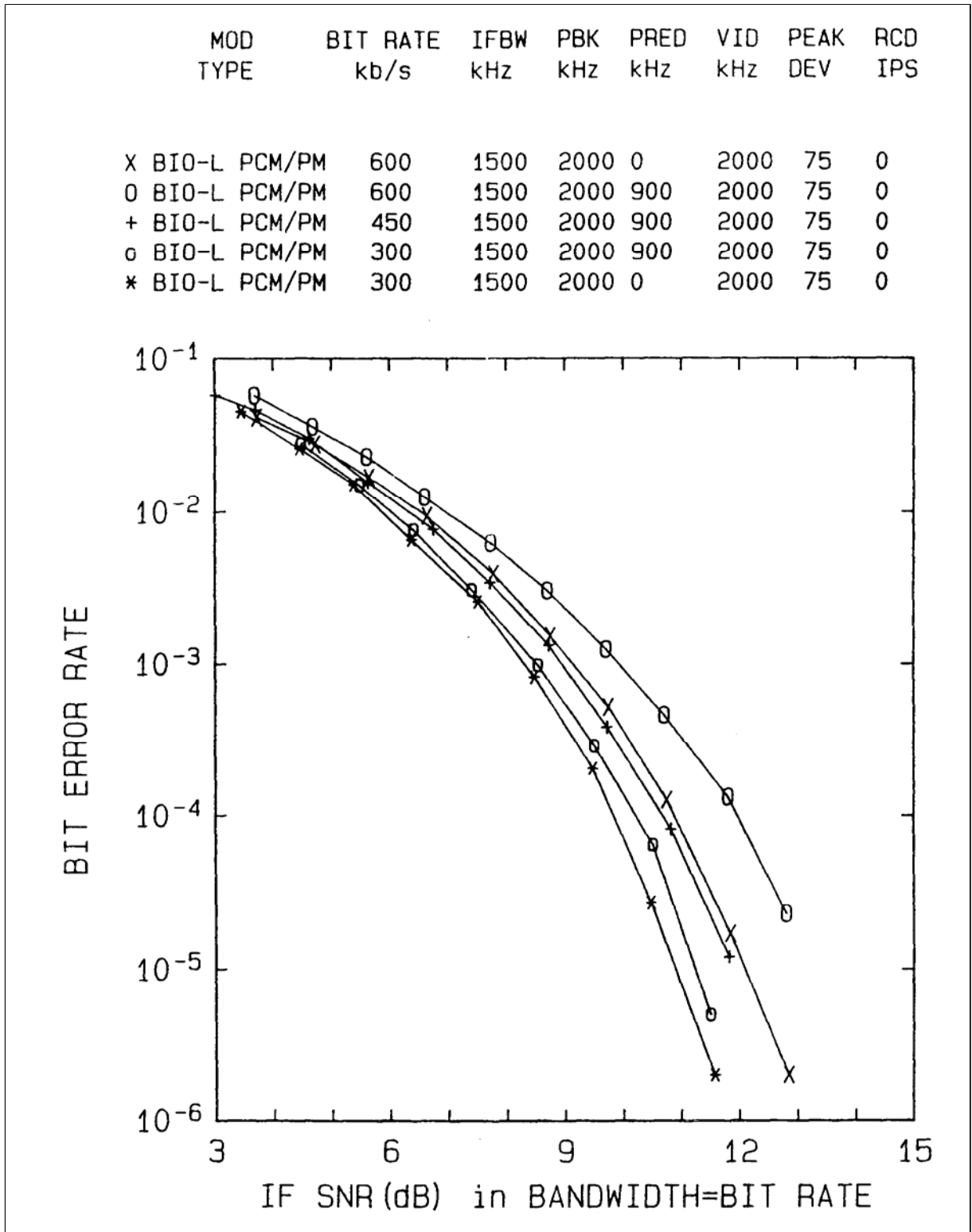

Figure 4-28. BER for 300, 450, and 600 kb/s biphasic PCM/PM.

4.5.9.1 Characteristics of the Biphas-Level Code Favorable to Serial HDDR.

- a. Only a small proportion of the total signal energy occurs near dc.
- b. The maximum time between transitions is 1-bit period.
- c. The symbols for a ONE and a ZERO are antipodal (i.e. the symbols are exact opposites). Thus, the bit error probability vs. SNR performance is optimum.
- d. Biphas-level can be decoded using existing bit synchronizers.
- e. Biphas-level is less sensitive to misadjustments of bias and reproducer equalizers than most other codes.
- f. Biphas-level performs well at low tape speeds and low bit rates.

The most unfavorable characteristic of the biphas-level code is that it requires approximately twice the bandwidth of NRZ; thus, the maximum bit packing density that can be recorded on magnetic tape is relatively low.

4.5.9.2 Characteristics of the RNRZ-L code that favor its use for serial HDDR.

- a. RNRZ-L requires approximately one-half the bandwidth of biphas-level.
- b. The symbols for a ONE and a ZERO are antipodal; therefore, the bit error probability versus SNR performance is optimum.
- c. The RNRZ-L decoder is self-synchronizing.
- d. The RNRZ-L data can be bit synchronized and signal conditioned using existing bit synchronizers with the input code selector set to NRZ-L.
- e. The RNRZ-L code is easily generated and decoded.
- f. The RNRZ-L data can be easily decoded in the reverse mode of tape playback.
- g. The RNRZ-L data are bit detected and decoded using a clock at the bit rate. Therefore, the phase margin is much larger than that of codes that require a clock at twice the bit rate for bit detection.
- h. The RNRZ-L code does not require overhead bits.

4.5.9.3 Unfavorable characteristics of the RNRZ-L code for serial HDDR.

- a. Long runs of bits without a transition are possible although the probability of occurrence is low, and the maximum run length can be limited by providing transitions in each data word.
- b. Each isolated bit error that occurs after the data has been randomized causes 3 bit errors in the derandomized output data.
- c. The decoder requires 15 consecutive error-free bits to establish and re-establish error-free operation.
- d. The RNRZ-L bit stream can have a large low frequency content. Therefore, reproducing data at tape speeds which produce PCM bit rates less than 200 kb/s is not recommended unless a bit synchronizer or playback amplifier with specially designed dc and low frequency restoration circuitry is available.

4.5.10 Randomizer for RNRZ-L. The randomizer is implemented with a network of shift registers and modulo-2 adders (exclusive-OR gates). The RNRZ-L bit stream is generated by adding (modulo-2) the reconstructed NRZ-L PCM data to the modulo-2 sum of the outputs of

the 14th and 15th stages of a shift register. The output RNRZ-L stream is also the input to the shift register (see Figure 4-29).

The properties of an RNRZ-L bit stream are similar to the properties of a pseudo-random sequence. A 15-stage RNRZ-L encoder will generate a maximal length pseudo-random sequence of $2^{15} - 1$ (32,767) bits if the input data consists only of ZEROS and there is at least a single ONE in the shift register. A maximal length pseudo-random sequence is also generated when the input data consists only of ONES and the shift register contains at least a single ZERO. However, if the shift register contains all ZEROS at the moment the input bit stream is all ZEROS, the RNRZ-L output bit stream will also be all ZEROS. The converse is also true: when the shift register is filled with ONES and the input bit stream is all ONES, the RNRZ-L output bit stream will contain only ONES. In these two cases, the content of the shift register does not change and the output data is not randomized. However, the randomizer is not permanently locked up in this state because a change in the input data will again produce a randomized output. In general, if the input bit stream contains runs of X bits without a transition with a probability of occurrence of $p(X)$, the output will contain runs having a length of up to $(X + 15)$ bits with a probability of $(2^{-15} \times p(X))$ bits. Therefore, the output can contain long runs of bits without a transition, but the probability of occurrence is low.

The RNRZ-L bit stream is decoded (derandomized) by adding (modulo-2) the reconstructed RNRZ-L bit stream to the modulo-2 sum of the outputs of the 14th and 15th stages of the shift register. The reconstructed RNRZ-L bit stream is input to the shift register (see Figure 4-30). RNRZ-L data which is reproduced using the reverse playback mode of operation is decoded by adding (modulo-2) the reconstructed RNRZ-L bit stream to the modulo-2 sum of the 1st and 15th stage outputs of the shift register (Figure 4-30). The effect is that the decoding shift register runs "backwards" with respect to the randomizing shift register.

Although the RNRZ-L decoder is self-synchronizing, 15 consecutive error-free bits must be loaded into the shift register before the output data is valid. A bit slip will cause the decoder to lose synchronization, and 15 consecutive error-free bits must again be loaded into the shift register before the output data is valid. The decoded output data, although correct, will contain the bit slip causing a shift in the data with respect to the frame synchronization pattern. Thus, frame synchronization must be re-acquired before the output provides meaningful data.

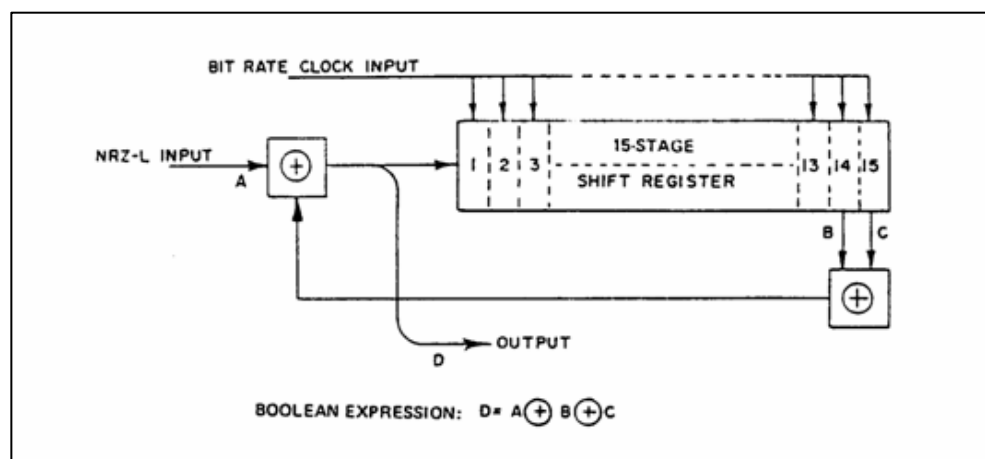

Figure 4-29. Randomizer.

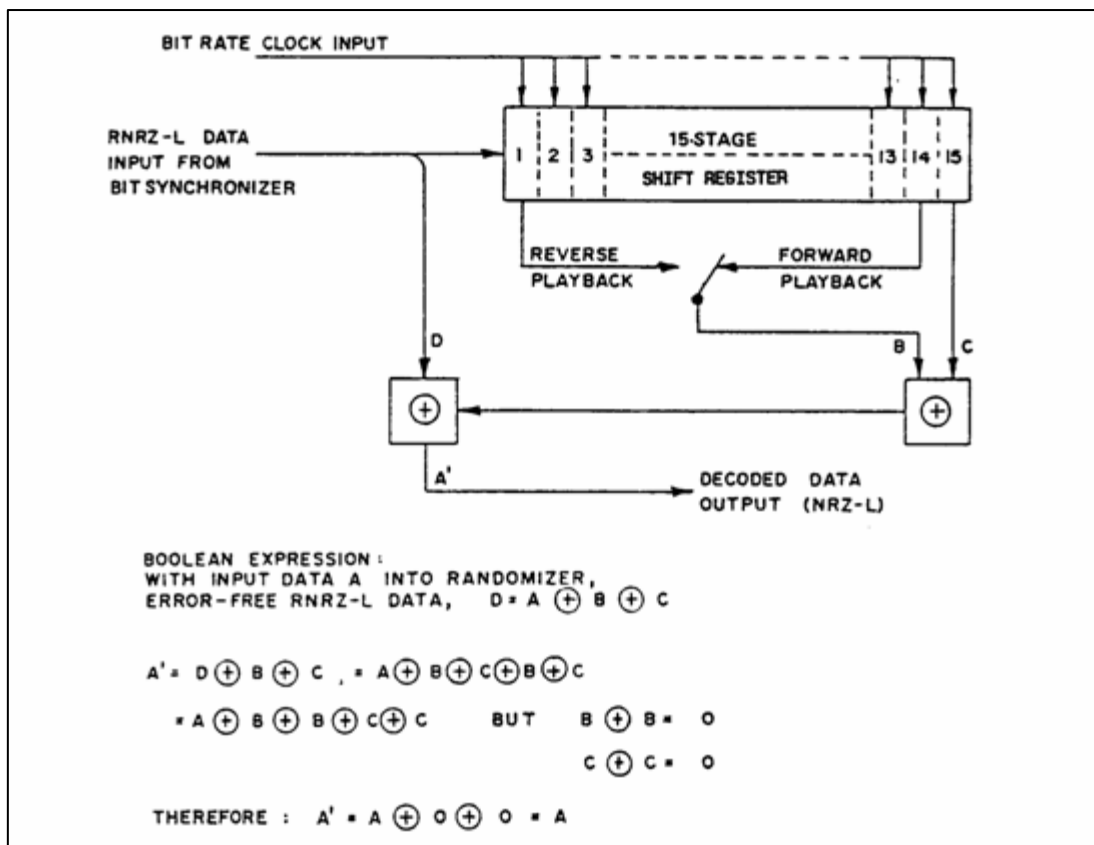

Figure 4-30. Derandomizer.

The RNRZ-L decoding system has an error multiplication factor of three for isolated bit errors (separated from adjacent bit errors by at least 15 bits). An isolated bit error introduced after randomization will produce three errors in the output data. The errors are the original bit in error, plus two additional errors 14 and 15 bits later. In addition, a burst of errors occurring after the data has been randomized will produce a burst of errors in the derandomized output. The number of errors in the output depends on the distribution of errors in the burst and can be greater than, equal to, or less than the number of errors in the input to the derandomizer. However, the derandomization process always increases the number of bits between the first and last error in the burst by 15. Errors introduced prior to randomization are not affected by either the randomizer or the derandomizer. The reverse decoder has the same bit error properties as the forward decoder.

Input data containing frequent long runs of bits without transitions creates potential dc and low frequency restoration problems in PCM bit synchronizers because of the low frequency cutoff of direct reproducer systems. The restoration problem can be minimized by reproducing the data at tape speeds which produce a bit rate for which the maximum time between transitions is less than 100 microseconds. Additional methods of minimizing these effects include either selecting bit synchronizers that contain special dc and low frequency restoration circuitry or recording data using biphase-level code.

Alignment of the reproducer system is very important to reproducing high quality PCM data, that is, with the lowest possible bit error probability. A PCM signature using the standard 2047-bit pseudo-random pattern, recorded on the leader and/or the trailer of the tape, provides a good method for reproducer alignment. When a pseudo-random bit error detection system is not available or when a PCM signature signal is not recorded, the recommended procedure for reproducer alignment involves the use of the eye pattern technique. The eye pattern is the result of super positioning the ZEROS and ONES in the PCM bit stream. The eye pattern is displayed on an oscilloscope by inserting the raw reproduced bit stream into the vertical input and the reconstructed bit-rate clock into the external synchronization input of the oscilloscope. The reproducer head azimuth, amplitude equalizers, and phase equalizers are then adjusted to produce the eye pattern with the maximum height and width opening.

4.6 Data Synchronizers and Discriminators

This section will briefly discuss PCM bit synchronizers, PCM decommutators, and FM discriminators.

PCM bit synchronizers are devices that reconstruct a binary data stream and a clock from a noisy analog signal. Most bit synchronizers allow the operator to select input code, input bit rate, loop bandwidth, bit detector type, and input impedance. The input code and bit rate should obviously be chosen to match the incoming data. The best choice for loop bandwidth depends on the application. A narrow bandwidth performs best when the SNR is low and when there are long periods with few or no transitions. A wide loop bandwidth performs best when the input data rate is unstable. The source of instability could be recorder/reproducer time base error or an unstable clock in the transmitting system. A good nominal choice is a loop bandwidth of approximately 0.3 percent. The problem with making the wrong choice is that additional bit slips can occur. Bit slips can create major problems in data quality. The best bit detector is usually the filter and sample (F/S) if the NRZ-L signal has been filtered significantly

(effective cutoff of 0.7 times the bit rate or lower) and the integrate and dump (I/D) with less filtering. PCM frame synchronizers use the data and clock outputs of the PCM bit synchronizer. The frame synchronizer first "finds" the synchronization pattern. The location of any word can then be found by counting the clock. Frame synchronizers usually have three levels of synchronization status: search, verify or check, and lock. The number of errors allowed in the pattern and the number of correct or incorrect patterns is frequently a variable. Many synchronizers also allow the selection of a "window" in which to look for the best match to the synchronization pattern. These windows are typically ± 1 or ± 2 bits around the expected synchronization location, which allows for a clock slip of 1 and 2 bits. Most decommutation and word selection systems hold the last "good" value when frame synchronization is lost. More data can be retrieved if errors are allowed in the pattern²³ and at least one bad pattern is allowed in lock mode. The data will also contain more noise because marginal data is more likely to be transferred to the output.

The probability of correctly detecting synchronization (Reference 4w) with a BER of p (independent errors assumed), a pattern length of n bits, and allowing q errors is

$$P_{\text{sync}} = \sum_{r=0}^q \frac{n!}{(n-r)!r!} p^r (1-p)^{n-r} \quad (4-14)$$

This detection probability is shown in Figure 4-31 and Figure 4-32 for synchronization pattern lengths of 16, 24, and 32 bits. The data in Figure 4-31 shows that to have a probability of 0.9 of detecting a 24-bit frame synchronization pattern when the BER is 0.1, a minimum of four errors should be allowed in the pattern. If the BER is reduced to 0.01 (see Figure 4-32), the probability of detecting the pattern will be greater than 0.97 if we allow one error. This data is useful in determining the parameters for the search, verify, and lock phases.

The probability of randomly detecting false synchronization with random data, a pattern length of n bits, and allowing q errors is

$$P_{\text{false sync}} = \frac{\sum_{r=0}^q \frac{n!}{(n-r)!r!}}{2^n} \quad (4-15)$$

Figure 4-33 presents data on the probability of false detection of the synchronization pattern for pattern lengths of 16, 24, and 32 bits. This data is useful for determining parameters in search mode. Assume we have a PCM minor frame, which is 4,000 bits long, and we would like the probability of detecting a false synchronization pattern in one minor frame time to be less than 0.2. Therefore, the probability of false detection of the synchronization pattern in any location would have to be less than $0.2/4000$ or 0.00005. The data in Figure 4-33 shows that no errors could be allowed in search mode with a 16-bit pattern, but two errors could be allowed with a 24-bit pattern, and four errors could be allowed with a 32-bit pattern. If the BER is 0.1, the probability of detecting the actual synchronization pattern with a 16-bit pattern and zero errors allowed is only 0.19. Therefore, we are more likely to detect a false pattern than the correct pattern. The acquisition time will be long under these conditions. The probability of correctly detecting the 24-bit pattern while allowing 2 errors is 0.56, while the probability of correctly detecting the 32-bit pattern while allowing 4 errors is 0.79, illustrating the advantages of long synchronization patterns when the data is noisy.

Some frame synchronizers also use an adaptive algorithm for frame synchronization. One adaptive technique is discussed in Reference [4x](#).

FM discriminators were discussed in paragraph [2.8](#). A general comment is that fixed channel discriminators perform better than tunable discriminators because the filter characteristics are usually better with fixed discriminators.

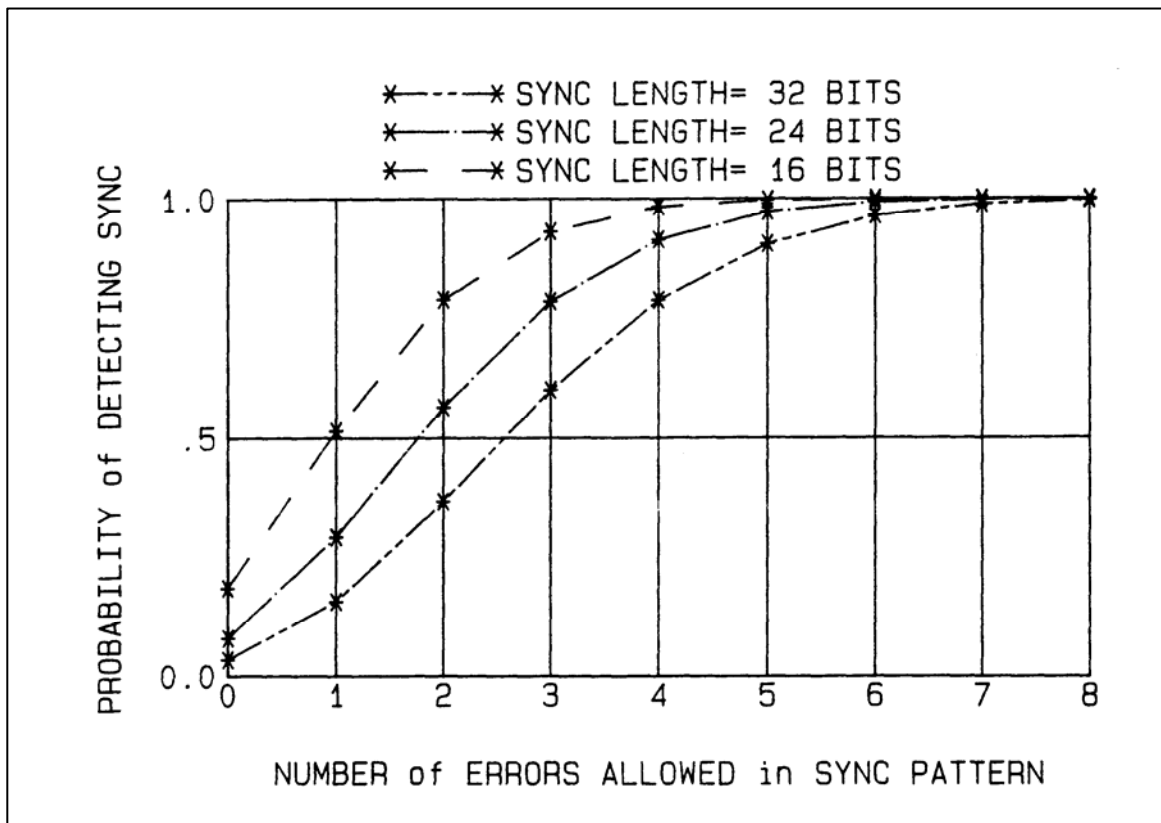

Figure 4-31. Probability of detecting sync pattern with BER = 0.1.

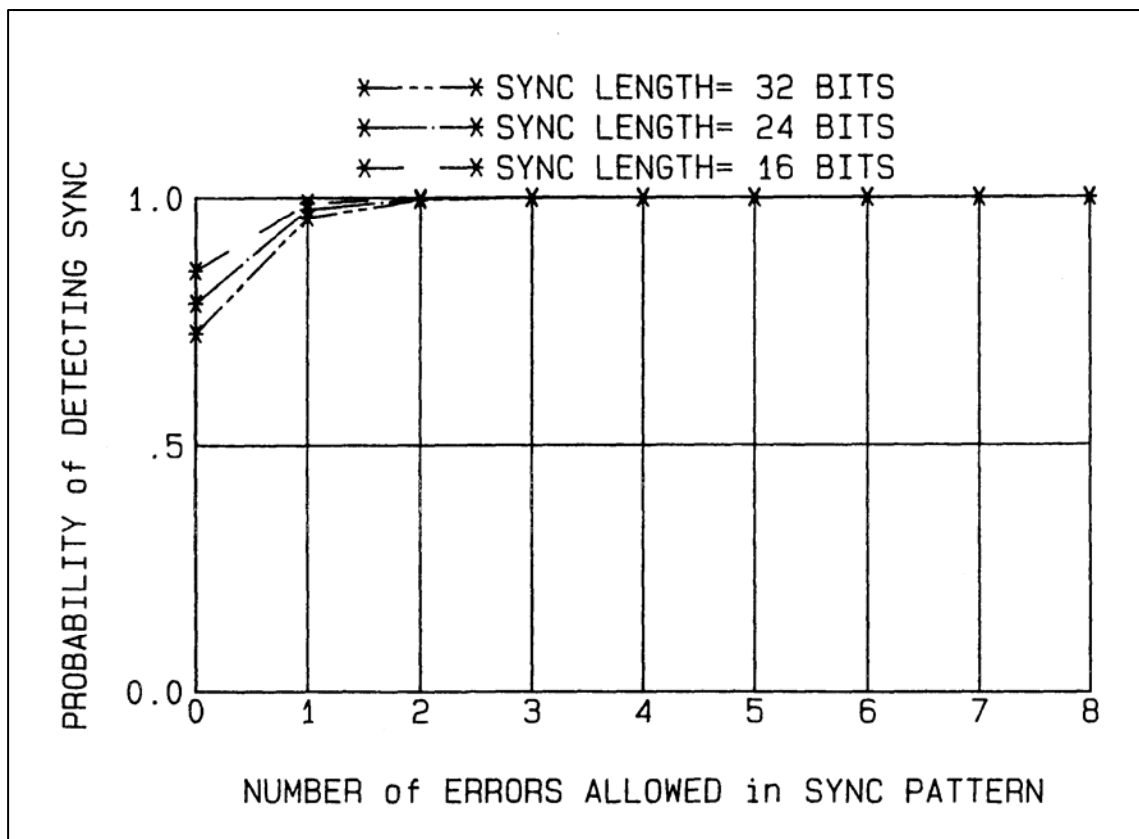

Figure 4-32. Probability of Detecting Sync Pattern with BER = 0.01.

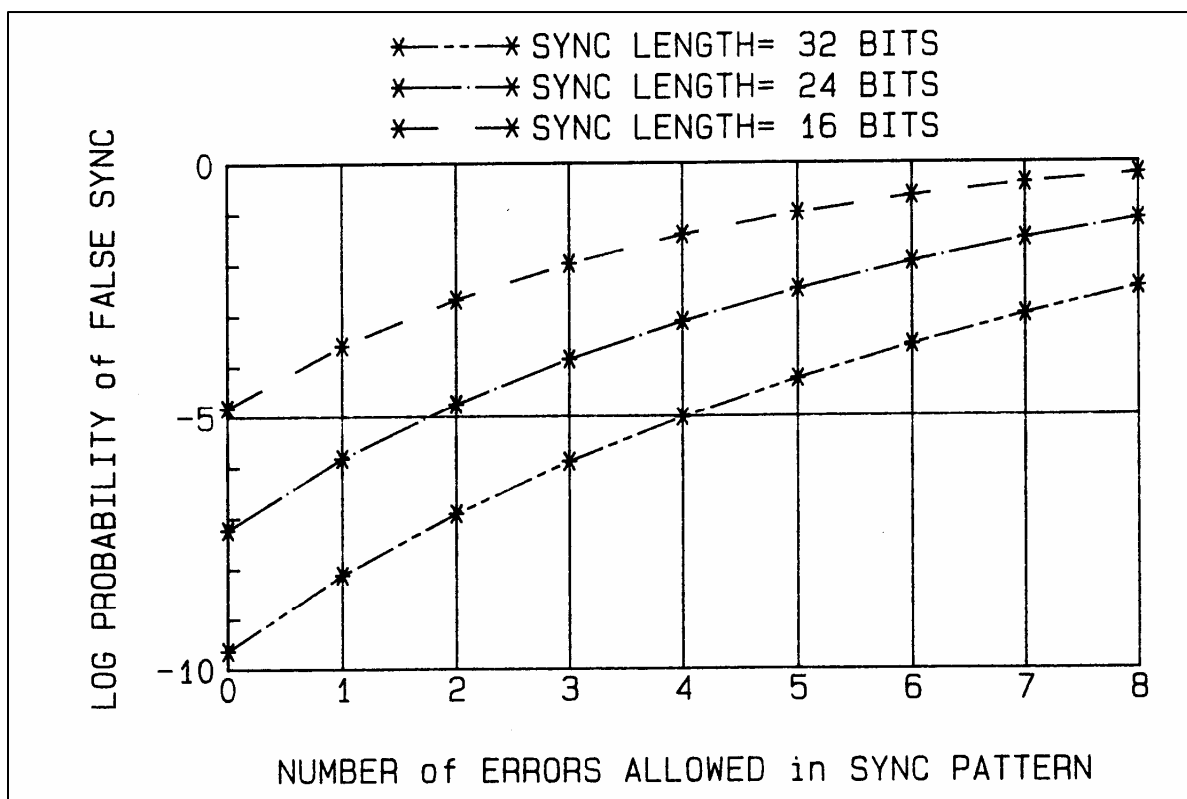

Figure 4-33. Probability of detecting false sync pattern.

4.7 Receiving/Recording System Parameter Selection Guidelines

4.7.1 Introduction. Important parameters to select in a telemetry ground station include:

- a. Receiver IF bandwidth
- b. Receiver oscillator type: XTAL, VFO, or AFC/APC
- c. Receiver AGC time constant
- d. Receiver video bandwidth and coupling (ac or dc)
- e. PM or PSK demodulator loop bandwidth
- f. Predetection or postdetection combining
- g. Predetection carrier frequency
- h. Predetection, postdetection direct, HDDR, or postdetection FM recording
- i. Tape speed
- j. Bit synchronizer loop bandwidth and bit detector type.

Since many of these subjects are discussed in Chapter [2](#) and Chapter [4](#), the discussions in this section will be brief.

4.7.2 Receiver IF Bandwidth. The best receiver IF bandwidth for an FM signal is the narrowest bandwidth that will pass the information without significant distortion. This is usually the narrowest IF bandwidth that is wider than two to three times the larger of maximum frequency of interest or peak deviation plus the frequency uncertainty in the system. The following IF bandwidths are listed in the Telemetry Standards (IRIG Standard 106): 300, 500, and 750 kHz and 1.0, 1.5, 2.4, 3.3, 4.0, 6.0, 10.0, 15.0, and 20.0 MHz. Not all of these

bandwidths may be available at a particular receiving facility. The best IF bandwidth for NRZ PCM/FM is 1 to 1.5 times the bit rate for peak deviations of 0.35 times the bit rate. If the bit rate is low, a larger deviation may be needed. If the peak deviation is 100 kHz and the bit rate is 10 kb/s, then a 300 kHz IF bandwidth would be a good choice. However, the system BER would normally be lower if a phase-modulated system with 90° peak deviation were used in this case. The performance of various IF bandwidths with various modulation methods is discussed in more detail in Chapter [2](#).

The best receiver IF bandwidth for a PM signal is the widest bandwidth that rejects all significant interfering signals. In practice, there is little to be gained by using an IF filter much wider than twice the premodulation bandwidth.

The IF filter should not be wider than twice the predetection carrier frequency. The problem with using wider filters is that the noise folds across zero frequency and back into the passband during the downconversion process.

4.7.3 Receiver Oscillator Type. The XTAL mode is best for most applications. The VFO mode is useful if the receiver operator needs to fine tune the receiver during an operation. The AFC mode may be useful for tracking signals that have large carrier frequency variations. However, AFC systems usually perform poorly at low SNRs and may cause problems with predetection combiners. APC may be needed for proper operation of PM and PSK demodulators.

4.7.4 Receiver AGC Time Constant. The best AGC time constant for data receivers is usually the fastest available time constant (frequently 0.1 ms). Tracking receivers may need longer time constants.

4.7.5 Receiver Video Bandwidth and Coupling. The receiver video bandwidth must be wide enough to pass the maximum frequency of interest. The dc coupling should be used if the transmitted signal has a significant dc component. Direct current is especially important for baseband PAM/FM.

4.7.6 PM and PSK Demodulator Loop Bandwidth. The best loop bandwidth depends on the application. If rapid, spurious, phase variations are expected because of unstable transmitter or flame attenuation, a wide loop bandwidth is needed to track the variations. A narrow loop bandwidth is best with a noisy signal and a stable transmitter.

4.7.7 Predetection or Postdetection Combining. A predetection combiner will always perform as well as or better than a postdetection combiner if the predetection combiner can maintain proper phase alignment of the signals. AFC systems introduce excessive phase noise, which tends to cause problems in the combiner phase-locked loop, therefore, AFC and predetection combining should not usually be used together. Postdetection combining does not work well with PCM/FM signals. Postdetection combining should not be used with PSK demodulator outputs unless a polarity alignment circuit is added to the combiner. Diversity combining is discussed in more detail in paragraph [4.4](#).

4.7.8 Predetection Carrier Frequency. The predetection carrier frequency should be at least twice the maximum information frequency of interest, meaning that a 900 kHz predetection carrier should not be used with NRZ PCM bit rates higher than 900 kb/s or biphase PCM bit rates higher than 450 kb/s. The predetection carrier frequency should also be larger than one-half of the IF bandwidth.

4.7.9 Recording Method. Predetection recording is recommended whenever possible because the signal has been processed less than with other methods. However, predetection recording and FM recording are the least efficient methods in terms of data bandwidth per inch per second of tape speed. Serial HDDR has the most record margin for PCM signals. Biphase (Manchester) signals are recommended for serial HDDR if the bit packing density is less than 15 kb/in for wideband systems or 30 kb/in for double density systems. Randomized NRZ-L is recommended for serial HDDR at packing densities up to 25 kb/in for wideband systems (50 kb/in for double density systems) as long as the reproduce bit rate is greater than 200 kb/s (400 kb/s for double density systems). Hybrid systems can be recorded directly on the baseband if low frequency response is not needed.

4.7.10 Tape Speed. The tape speed is determined by the maximum frequency to be recorded. Wideband systems have a bandwidth of 1 MHz at 60 ips while double density systems have a bandwidth of 1 MHz at 30 ips.



Paragraph 4.7.9 and paragraph 4.7.10 above relate to analog magnetic tape recording and may not be relevant to digital recording.

4.7.11 Bit Synchronizer Loop Bandwidth and Bit Detector Type. The best loop bandwidth depends on the application. Narrow bandwidths perform better in noisy environments if the bit rate is stable, while wide bandwidths perform better with unstable bit rates. Recorder time base error and unstable transmitting system clock are two sources of bit rate instability. A loop bandwidth of 0.3 percent is a good choice for most applications. The best bit detector for a heavily filtered signal is the filter and sample (F/S) detector. The best bit detector for a relatively unfiltered data stream is usually an integrate and dump (I/D) detector.

4.8 Data Quality Monitoring

The data quality can be monitored at various points in the telemetry ground station. This subsection will discuss monitoring the data quality using calibrated AGCs, spectrum analyzer displays of predetection and postdetection signals, and oscilloscope displays of postdetection signals. Time division multiplex systems can also be monitored using the synchronization status of a decommutator. The data quality of individual demultiplexed signals can be monitored using strip chart recorders.

The received data quality can be monitored by using a calibrated AGC voltage to estimate received SNR along with monitoring the predetection signal on a spectrum analyzer

and the video output on an oscilloscope. The predetection and video outputs are monitored to look for improper tuning and filtering.

Typical oscilloscope eye patterns are shown in Figure 4-34 and Figure 4-35 for IF SNRs from 18 dB to 2 dB. These photos can be used to get a qualitative estimate of SNR and data quality for PCM signals. The BER was less than 10^{-8} for the 14 and 18 dB IF SNRs. The BER was approximately 10^{-4} at a 10 dB IF SNR, 1.4×10^{-2} at a 6 dB IF SNR, and 1.2×10^{-1} at a 2 dB IF SNR.

Figure 4-36 through Figure 4-40 show typical IF spectra for randomized NRZ-L PCM/FM signals with an IF bandwidth of 1.5 times the bit rate and a peak deviation of 0.35 times the bit rate. These figures show that we can estimate the IF SNR by subtracting approximately 3 dB from the ratio of the signal in the center of the band to the noise at the spectral minimum. The spectral minimum in this case is at ± 65 percent of the bit rate from the receiver output center frequency. This estimate is quite accurate for IF SNRs less than 15 dB as long as the deviation is approximately 0.35 times the bit rate. The correction factor (3 dB in this case) is a function of the ratio of IF bandwidth to bit rate. This method does not work well for IF bandwidths approximately equal to the bit rate. The spectrum of the video signal can also be used to estimate SNR.

The tape recorder outputs should be monitored to verify that the tape recorder is working properly. The recorder output also includes the entire receive/record path and if the signal is good at the recorder output, it must have been good at all points upstream in the signal path. As a result, the recorder output is the best single point to monitor the data quality.

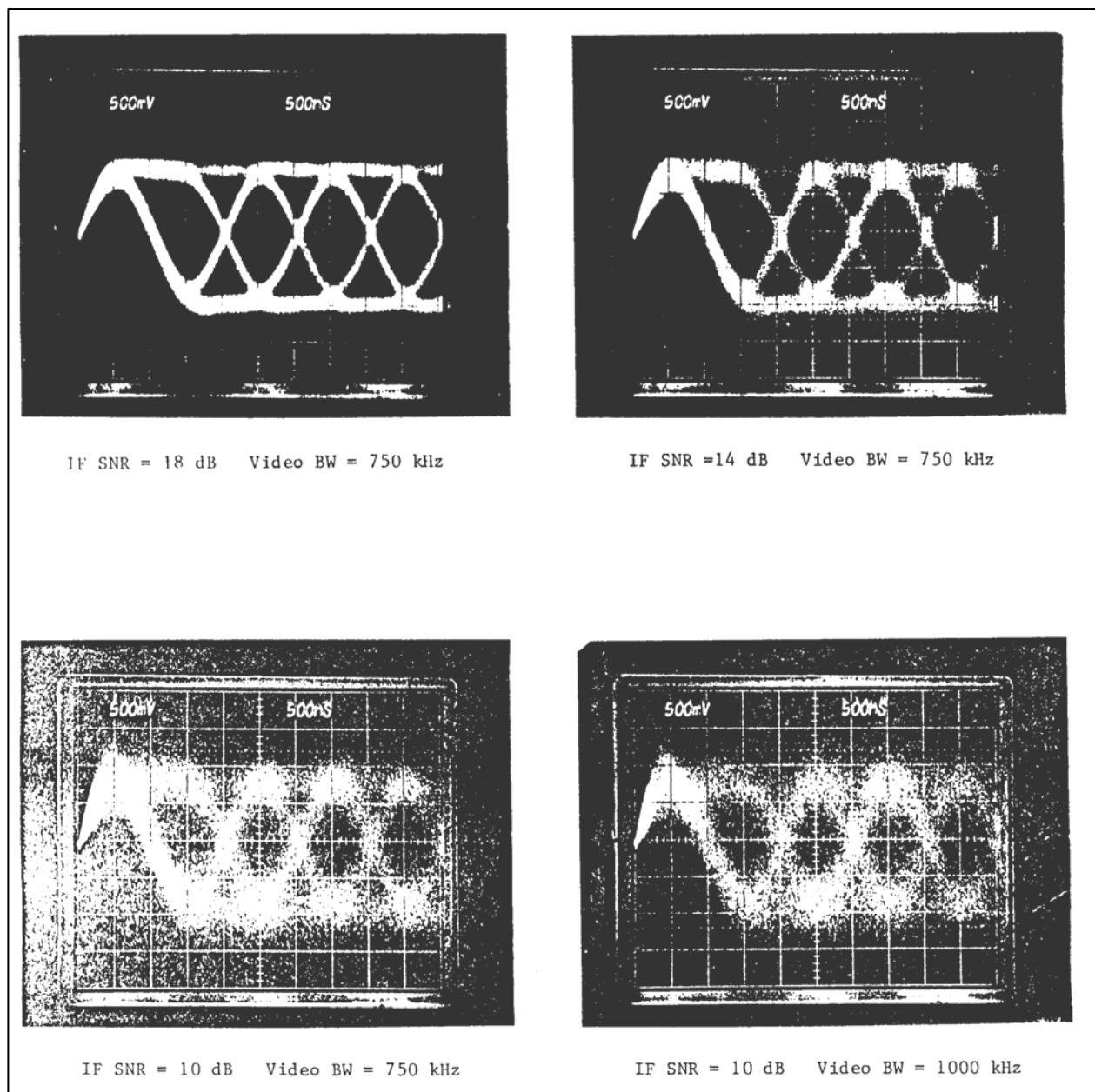
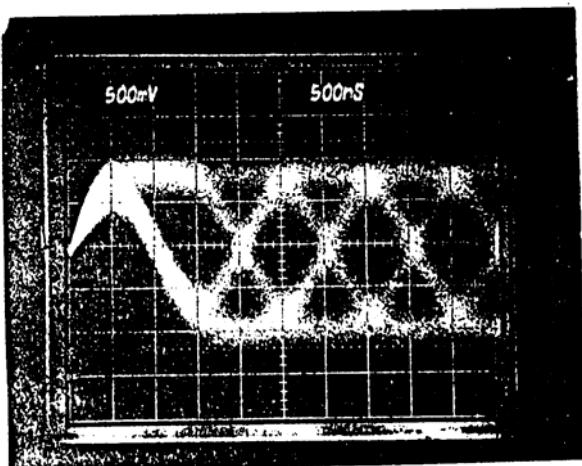
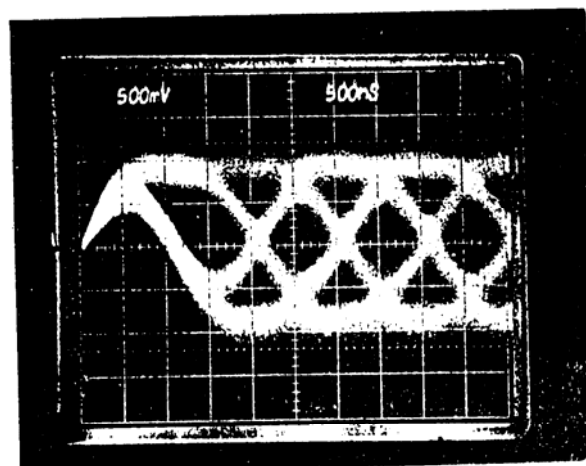

Figure 4-34. Oscilloscope eye patterns at various IF SNRs. bit rate = 1 Mb/s and IF BW = 1500 kHz.



IF SNR = 10 dB Video BW = 500 kHz
IF BW = 1500 kHz



IF SNR = 10 dB Video BW = 500 kHz
IF BW = 1000 kHz

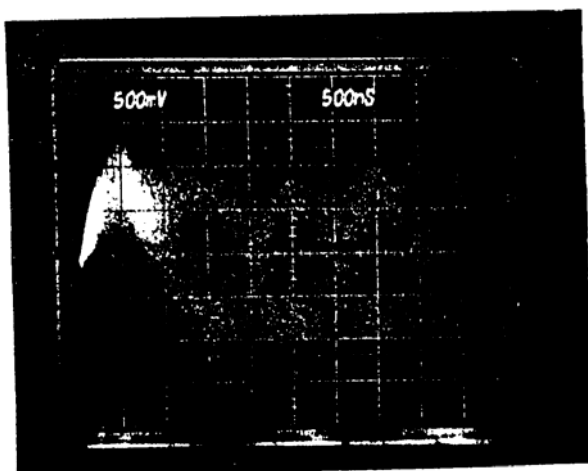

IF SNR = 6 dB Video BW = 750 kHz
IF BW = 1500 kHz

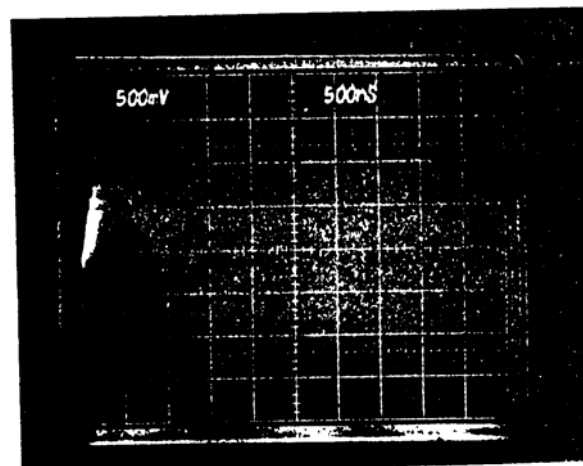

IF SNR = 2 dB Video BW = 750 kHz
IF BW = 1500 kHz

Figure 4-35. Oscilloscope eye patterns at various IF SNRs. Bit rate 1 Mb/s.

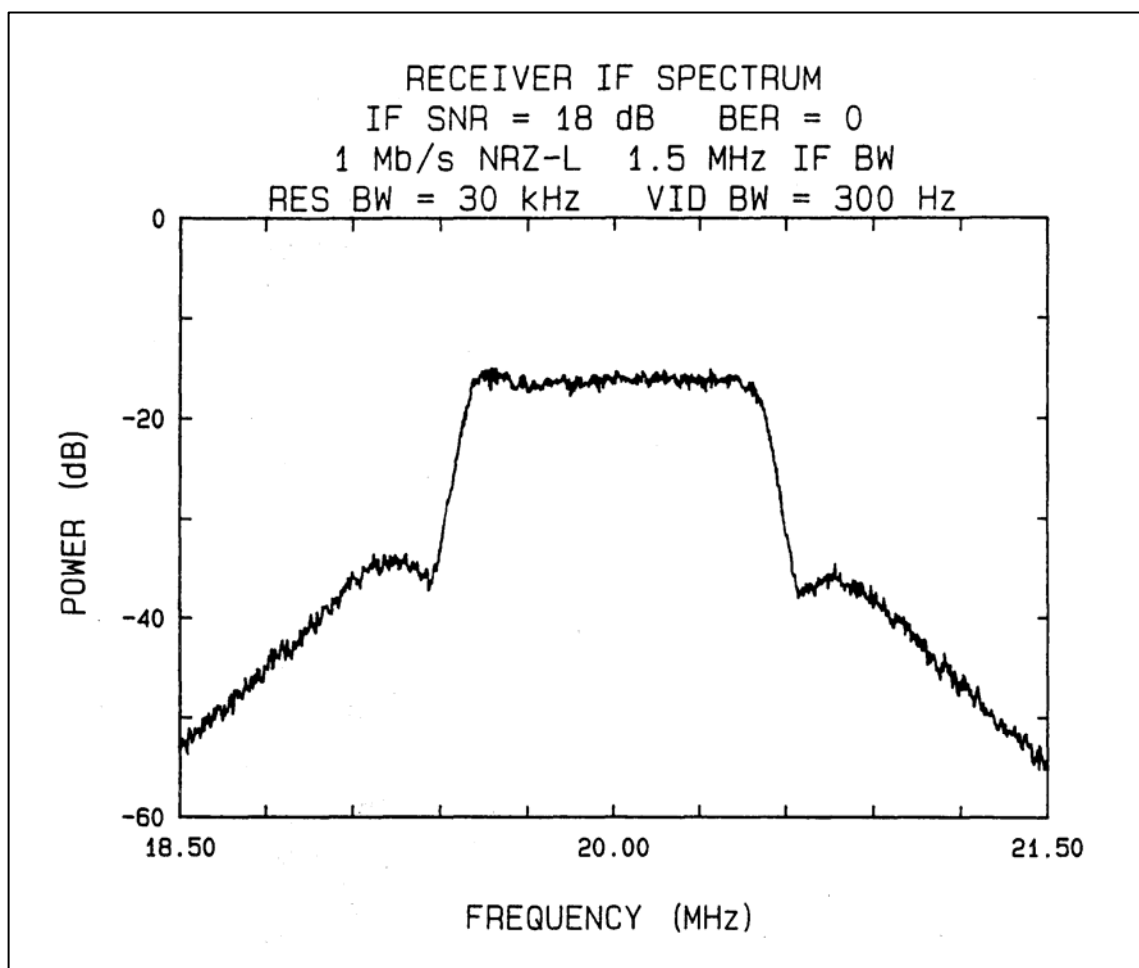

Figure 4-36. Receiver IF Spectrum at 18 dB IF SNR.

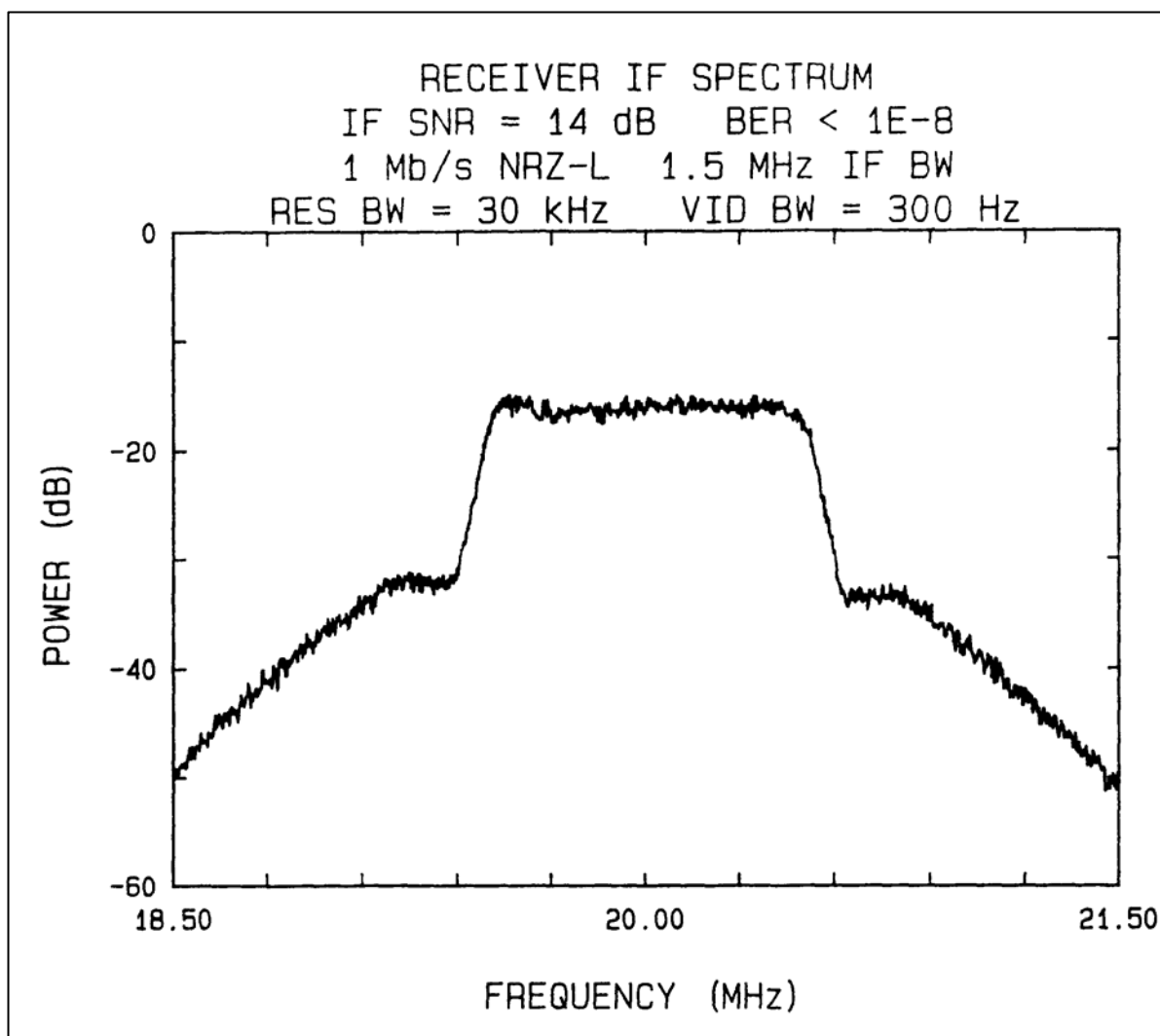

Figure 4-37. Receiver IF Spectrum at 14 dB IF SNR.

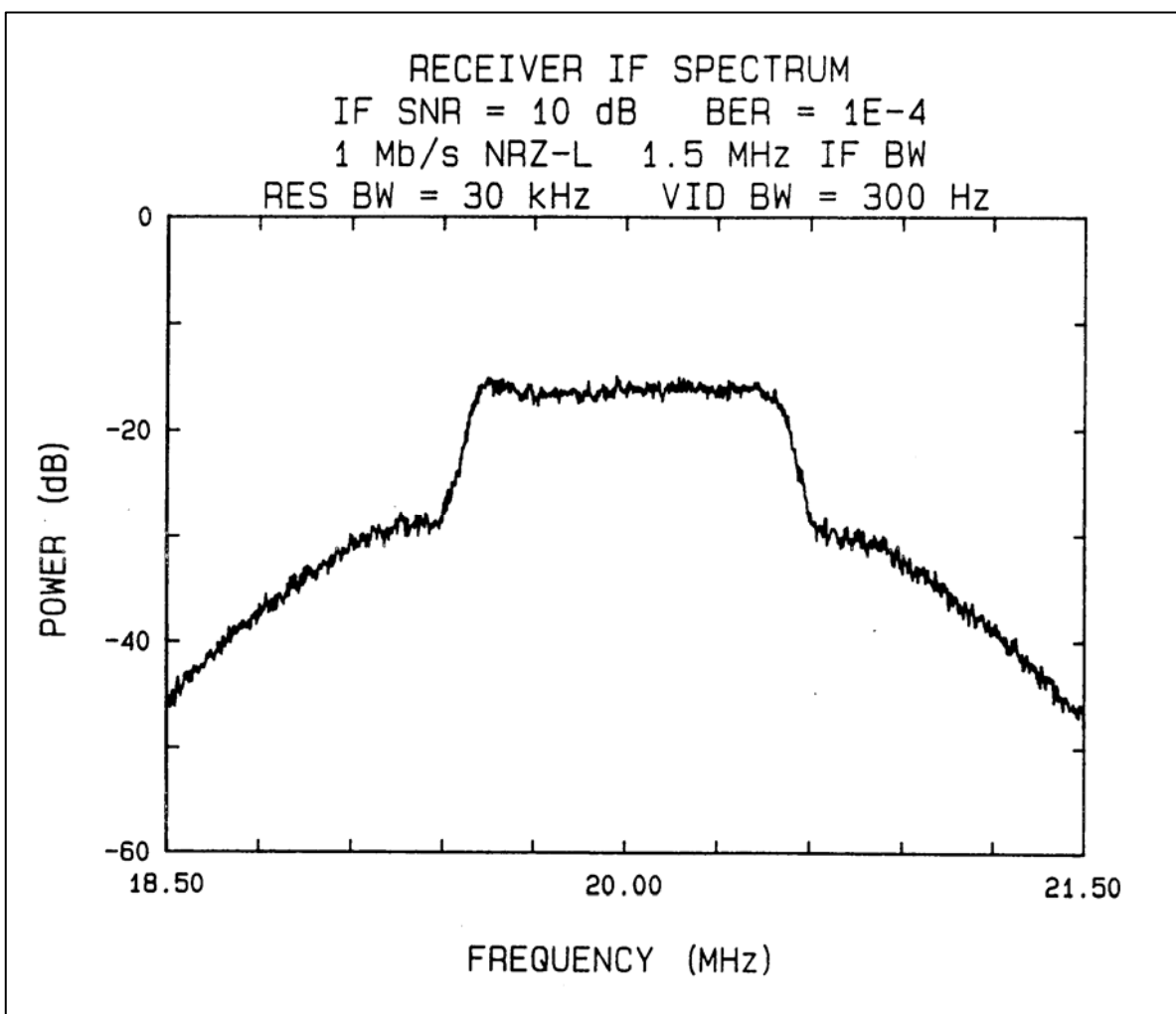

Figure 4-38. Receiver IF Spectrum at 10 dB IF SNR.

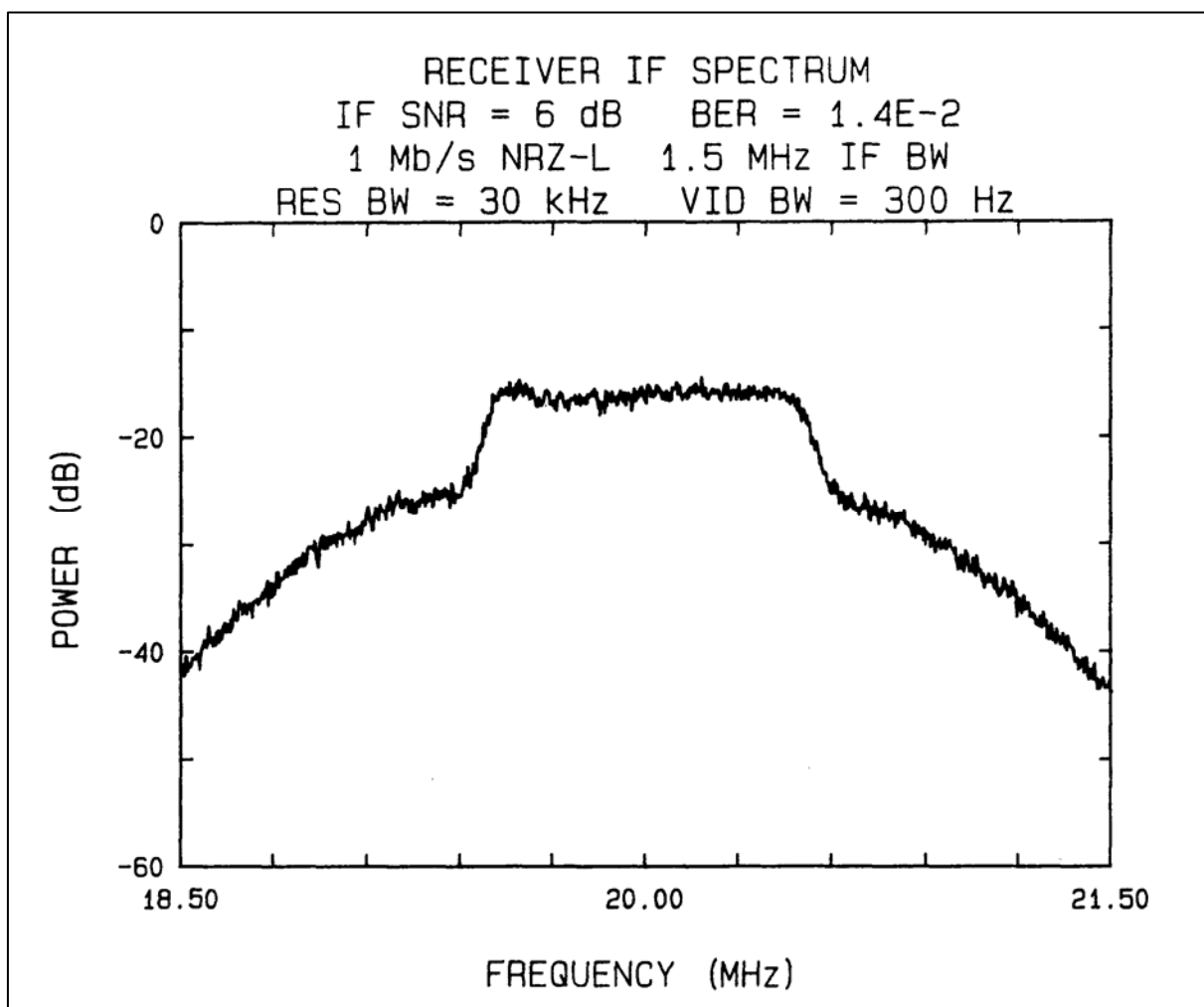

Figure 4-39. Receiver IF Spectrum at 6 dB IF SNR.

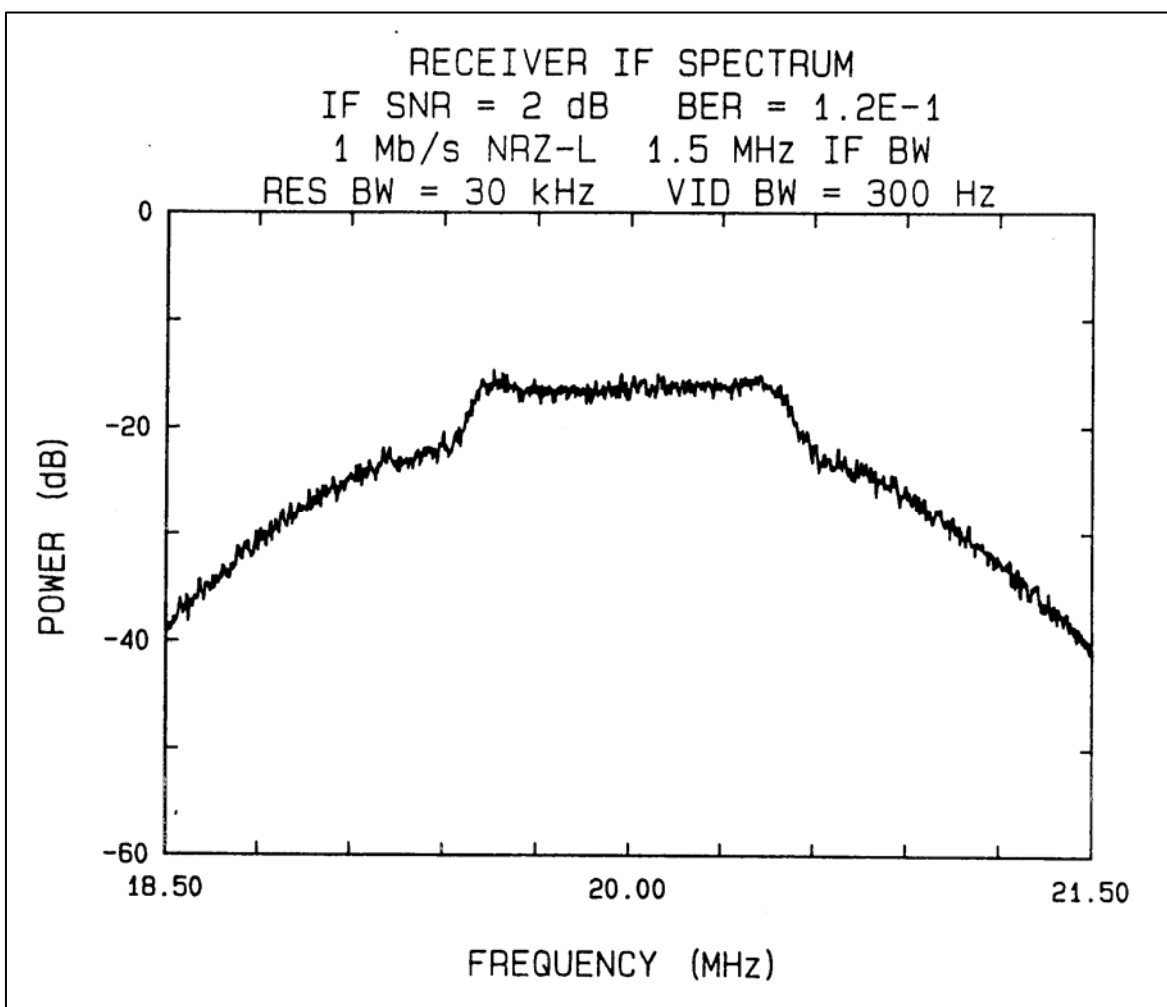

Figure 4-40. Receiver IF spectrum at 2 dB IF SNR.

4.9 References for Chapter 4

- 4a. Secretariat, Range Commanders Council. End-to-End Test Methods for Telemetry Systems. White Sands Missile Range, NM, RCC Document 118-79 Volume I.
- 4b. Hedeman, W. R. "The Sun as a Calibration Source for L- and S-band Telemetry". in Proceedings of the International Telemetry Conference, Vol. IV, pp.330-342, 1977.
- 4c. Guidice, D. A. and J. P. Castelli. "The Use of Extraterrestrial Radio Sources in the Measurement of Antenna Parameters", IEEE Transactions on Aerospace and Electronic Systems, Vol. AES-7 No. 2, March, 1971.
- 4d. Secretariat, Range Commanders Council. Test Methods for Data Multiplex Equipment. White Sands Missile Range, NM, RCC Document 118-79 Volume-IV.
- 4e. Johnson, R. C., and H. Jasik. Antenna Engineering Handbook, Second Edition, McGraw-Hill, New York, 1984.
- 4f. Stutzman, W. L., and G. A. Thiele. Antenna Theory and Design, John Wiley, New York, 1981.
- 4g. Pettai, R. Noise in Receiving Systems. Wiley, New York, 1984.
- 4h. Gregg, W. D. Analog and Digital Communication. Wiley, New York, 1977.
- 4i. Gagliardi, R. M. Introduction to Communications Engineering. Wiley, New York, 1978.
- 4j. Hill, E.R. "AM/AGC weighted Pre-Detection Diversity Combining," in Proceedings of International Telemetry Conference, Vol. 13, pp 215-238, Oct. 1977.
- 4k. Berns, K.L. "Benefits of Polarization Diversity Reception," in Proceedings of International Telemetry Conference, Vol. 20, pp 627-642, Oct. 1984.
- 4l. Secretariat, Range Commanders Council. Telemetry Standards. White Sands Missile Range, NM, RCC, May 1986. (IRIG Standard 106).
- 4m. Jorgensen, F. The Complete Handbook of Magnetic Recording. TAB Books, Blue Ridge Summit, PA, 1980.
- 4n. Camras, M. Magnetic Tape Recording. Van Nostrand, New York, 1985.
- 4o. White, R. Introduction to Magnetic Recording. IEEE Press, New York, 1984.
- 4p. Daniel, E. D. and C. D. Mee, Eds. Magnetic Recording-vol. I: Technology. McGraw-Hill, New York, 1986.
- 4q. Mee, C. D. and E. D. Daniel, Eds. Magnetic Recording-vol. II: Applications McGraw-Hill, New York, 1987.

- 4r. Mallinson, J. C. Foundations of Magnetic Recording. Academic Press, Orlando, FL, 1987.
- 4s. Proceedings of the IEEE, November 1986, (Special Issue on Magnetic Recording).
- 4t. Wallace, R. L. "The Reproduction of Magnetically Recorded Signals," Bell System Technical Journal, October 1951.
- 4u. Law, E. L. Serial High Density Digital Recording Using a Wideband Analog IRIG Recorder/Reproducer. Pacific Missile Test Center, Point Mugu, CA, May 1981.
- 4v. Kalil, F. and A. Buschman (Eds.) High-Density Digital Recording. NASA Reference Publication 1111, September 1985.
- 4w. Hill, E. R., "Techniques for Synchronizing Pulse-Code-Modulated Telemetry". Proceedings of the 1963 National Telemetry Conference, paper 3-3.
- 4x. Cox, T. F. "Analysis of an Adaptive Sequential Probability Ratio Test Type of PCM Frame Synchronizer". Proceedings of the International Telemetry Conference, vol. XXII, 1986, pp 61-68.
- 4y. Gagliardi, R. M. Introduction to Communications Engineering. Wiley, New York, 1978.
- 4z. Tjhung, T. T., and Wittke, P. H. "Carrier Transmission of Binary Data in a Restricted Band," in IEEE Transactions on Communications, Vol. COM-18, pp. 295-304, August 1970.
- 4aa. Cartier, D. E. "Limiter-Discriminator Detection Performance of Manchester and NRZ Coded FSK," in IEEE Transactions of Aerospace and Electronic Systems, Vol. AES-13, pp. 62-70, January 1977.
- 4bb. Korn, I. "Error Probability and Bandwidth of Digital Modulation," in IEEE Transactions on Communications, Vol. COM-28, pp. 287-290, February 1980.
- 4cc. Tan, C. H., T. T. Tjhung, and H. Singh. "Performance of Narrow-Band Manchester Coded FSK With Discriminator Detection," in IEEE Transactions on Communications, Vol. COM-31, pp. 659-667, May 1983.
- 4dd. Taub, H. and D. L. Schilling. Principles of Communication Systems, McGraw-Hill, New York, pp 162-179, 1971.
- 4ee. Gregg, W. D. Analog and Digital Communication, John Wiley and Sons, New York, pp 267-294, 1977.
- 4ff. Downing, J. J. Aerospace Telemetry, Volume I, (ed. by H. L. Stiltz), Prentice-Hall, Englewood Cliffs, NJ, pp 83-141, 1961.

- 4gg. Hochman, D. Handbook of Telemetry and Remote Control, (ed. by E. L. Gruenberg), McGraw-Hill, New York, pp 9-2 to 9-198, 1967.
- 4hh. Heberling, E. D. An Experimental Evaluation of the Characteristics of PAM-NRZ/FM Telemetry Systems, Naval Ordnance Laboratory Corona, Corona, California, September 1967. (NOLC Report 741).
- 4ii. Nichols, M. H. and L. L. Rauch. Radio Telemetry, J. Wiley, 1956.
- 4jj. Law, E. L., E. T. Kimball, and M. H. Nichols. "Relationship of Noise Power Ratio to FM/FM Data Quality", in Proceedings of the International Telemetry Conference, Vol. XII, pp 234-250, 1976.
- 4kk. Law, E. L., E. T. Kimball, and M. H. Nichols. Relationship of Noise Power Ratio to Subcarrier Discriminator Signal-to-Noise Ratio, Pacific Missile Test Center, Point Mugu, CA, Aug 1975. PMTC TP-75-21.
- 4ll. Sklar, B. "What the System Link Budget Tells the System Engineer or How I Learned to Count in Decibels", in Proceedings of the International Telemetry Conference, Vol. XV, pp 331-344, 1979.
- 4mm. Lantz, N. F., and M. H. Nichols. "Approximate Design Formulae and Procedures for Designing Hybrid Telemetry Systems Using an FM Carrier", in Proceedings of the International Telemetry Conference, Vol. XIII, pp 261-271, 1977.
- 4nn. Law, E. L. Pulse Code Modulation Telemetry, Properties of Various Binary Modulation Types. Pacific Missile Test Center, Point Mugu, CA, TP000025, June 1984.

This page intentionally left blank.

GLOSSARY OF TERMS

- A -

ACQUISITION: Process of acquiring synchronization; can be clock synchronization or receiving antenna pointing toward the transmitting antenna.

ACQUISITION TIME: The time interval required to establish clock synchronization or antenna track.

ALIASING EFFECT: Apparent downward shift in frequency of components, which are higher than one-half the sampling frequency resulting from a sampling rate which is too low in frequency.

AMPLIFIER: An electronic device used to increase the amplitude of electronic signals.

AMPLIFIER, LOW NOISE: An amplifier whose noise temperature is low.

AMPLITUDE EQUALIZATION: The process of reducing frequency response distortion by the introduction of networks to compensate for the differences in attenuation at various frequencies.

ANTENNA PATTERN (RADIATION PATTERN): A graphical representation of the radiation properties of the antenna as a function of space coordinates. Radiation properties include power, phase, and polarization. In the usual case, the radiation pattern is determined in the far field region and is represented as a function of directional coordinates.

ANTIPODAL: Diametrically opposite, exact opposites; for example, the NRZ-L symbols for ONE and ZERO are referred to as antipodal symbols.

ATTENUATION, ATMOSPHERIC: The attenuation of a radio signal as it passes through the atmosphere because of particles in the atmosphere, for example, raindrops, water vapor, and other gases.

ATTENUATION, FLAME: The attenuation of a radio signal as it passes through the ionized gas and particles of the exhaust from a rocket motor.

AZIMUTH ALIGNMENT (FOR RECORDER/REPRODUCER HEADS): Alignment of the recording and reproducing head gaps to provide system-to-system compatibility and to produce the optimum output. Alignment considerations must include the record head gap, the reproduce head gap, and the dynamic path of the magnetic tape.

- B -

BANDWIDTH: A range of frequencies that conform to a specified standard, usually ± 3 dB of the amplitude of the reference frequency. The information capacity of a channel.

BANDWIDTH (CONTINUOUS FREQUENCY BAND): The difference between the limiting frequencies. The range of frequencies within which performance, with respect to some characteristic, falls within specific limits.

BANDWIDTH, NECESSARY: The International Telecommunication Union (ITU) and the National Telecommunications and Information Administration (NTIA) have defined necessary bandwidth as follows: "For a given class of emission, the width of the frequency band which is just sufficient to ensure the transmission of information at the rate and with the quality required under specified conditions."

BANDWIDTH, OCCUPIED: The ITU and NTIA have defined occupied bandwidth as follows: "The width of a frequency band such that below the lower and above the upper frequency limits, the mean powers emitted are each equal to a specified percentage of the total mean power of a given emission." This percentage is frequently specified as 0.5 percent and the resulting bandwidth referred to as the 99 percent power bandwidth.

BASEBAND (CARRIER OR SUBCARRIER TRANSMISSION SYSTEM): The band of frequencies occupied by the signal before it modulates the carrier (or sub-carrier) frequency to form the transmitted signal. The signal in baseband ranges over a distinctly lower frequency than the carrier frequency and may include a direct current (dc) component.

BASELINE RESTORATION: Recovery of the dc baseline reference of a signal that has been modulated by the effects of long strings of ONES or ZEROS.

BEAMWIDTH (ANTENNA): Half power beamwidth plane containing the direction of the maximum value of the beam. The angle between the two directions in which the radiation intensity is one-half the maximum value of the beam.

BIAS SIGNAL, HIGH FREQUENCY: A high frequency (usually at least three times the maximum signal to be recorded) sinusoidal signal linearly added to the analog data signal to linearize the magnetic recording/reproducing characteristic.

BI-LEVEL DIGITAL SIGNAL: A digital signal that is comprised of only two levels.

BI-PHASE LEVEL (BI ϕ -L): A method of representing digital data where a level change occurs at the center of every bit period. A ONE is represented by a "high" level with a mid-bit transition to the "low" level. A ZERO is represented by a "low" level with a mid-bit transition to the "high" level.

BINARY CODE: A method of representing numbers using two states such as on or off, high level or low level.

BIT: An abbreviation for binary digit.

BIT ERROR: A bit error has occurred when the expected bit value is not present; for example, a ZERO occurring when a ONE is expected, or a ONE occurring when a ZERO is expected.

BIT ERROR PROBABILITY (BEP): The ratio of the number of bits in error to the number of bits transmitted during a given time interval.

BIT ERROR RATE (BER): The number of bits in error during a given time interval or a given number of bits.

BIT PACKING DENSITY (LINEAR): The number of bits of useful information contained within a given linear dimension, usually expressed in bits per inch or millimeter.

BIT RATE: The speed at which bits are transmitted, usually expressed in bits per second (b/s or bps).

BIT SLIP: The increase or decrease in detected bit rate by one or more bits with respect to the actual bit rate.

BIT SLIPPAGE PROBABILITY (BSP): The ratio of the number of bits gained or lost (slipped) to the number of bits transmitted during a given interval of time.

BIT SLIPPAGE RATE: The number of bits gained or lost (slipped) during a given time interval or given number of bits.

BIT STREAM: A continuous series of bits transmitted over a channel.

BIT SYNCHRONIZER: An electronic device that produces a reconstructed version of the transmitted clock and bit stream from an input bit stream that may have been contaminated by noise and distortion.

BIT SYNCHRONIZATION: In step or in phase as applied to a digital sequence, for example, a bit sequence in step/in phase with its source clock.

BURST: A continuous group of events occurring together in time. An analog signal sequence or pulse train that starts at a prescribed time and continues for a specified duration or number of cycles.

BURST ERROR: A series of closely spaced errors occurring in a transmission channel caused by a common event.

BYTE: A sequence of adjacent binary bits of specified length, for example, 4, 6, or 8 bits in length. A byte is usually defined to be 8 bits long.

- C -

CARRIER: An analog signal of constant amplitude and frequency that is modulated by information signals to produce a signal suitable for transmission.

CARRIER-TO-NOISE RATIO (CNR): The ratio of carrier to noise after bandlimiting but before any nonlinear process such as amplitude limiting.

CENTER FREQUENCY: The average frequency of a signal when modulated by a symmetrical signal.

CHANNEL: The path through which signals flow.

CLOCK: A signal waveform used to synchronize digital circuits.

CLOCK (RECONSTRUCTED): A clock signal that is recovered from the data at the data processing site.

CLOCK SLIP: An increase or decrease of more than 180° of the reconstructed clock relative to a perfectly recovered clock.

CLOCK SYNCHRONIZATION: The process of aligning a clock at a remote site to a clock at the originating site.

CLOCKING: Communication signal time synchronization information.

CODING: Method by which digital data is converted, following a prescribed set of rules.

COMMUTATION: Sequential sampling, on a repetitive basis, of multiple data sources for transmitting and/or recording on a single channel basis.

COMMUTATOR: A device used to accomplish time-division multiplexing by repetitive sequential switching techniques.

COMPRESSION POINT, 1 dB: The point at which the gain of an amplifier is reduced by 1 dB with respect to its small signal gain.

CONSTANT BANDWIDTH: A frequency division multiplexing system in which each channel occupies the same bandwidth regardless of its center frequency. The amount of deviation is held within an allocated bandwidth and is not determined as a percentage of the center frequency as in a proportional bandwidth system.

CONTINUOUS PHASE MODULATION: A constant amplitude modulation method in which there are no discrete steps in phase.

CORRELATION DETECTION: A method of detection in which a signal is compared point-to-point with an internally generated reference. The output of such a detector is a measure of the degree of similarity of the input and reference signals. The reference signal is constructed in such a way that it is at all times a prediction, or best guess, of what the input signal should be at that time.

CROSS MODULATION: A type of intermodulation of a desired carrier by undesired carriers.

CROSSPLAY: Reproducing a previously recorded tape on a system other than that used to record the tape.

CROSSTALK: Interference in a given transmitting or recording channel that has its origin in another channel. Undesired signal energy appearing in one signal path as a result of coupling from other signal paths.

CUTOFF FREQUENCY: The frequency that marks the edge of the passband of a filter and the beginning of the transition to the stopband. It is usually defined to be the frequency at which the signal is attenuated by 3 dB relative to the response at a reference frequency.

- D -

DATA AZIMUTH (DYNAMIC): The departure from the nominal head segment gap azimuth angles (static) because of the dynamic interface between the heads and the moving tape.

DATA BANDWIDTH: The difference between the highest and lowest frequency of the data to be transmitted, usually defined by the -3 dB points.

DATA CONVERSION: The process of changing data from one form of representation to another.

DATA MULTIPLEXING: The process of combining two or more signals into a single composite signal. The two basic methods of multiplexing involve the separation of signals by time division and frequency division.

DATA QUALITY: A measure of "goodness" of data. The measure of goodness can be such items as bit error rate, signal-to-noise ratio, and maximum (or rms) error as a percentage of full scale.

DATA TRACK: The recorder channel (track) on which data has been or is to be recorded.

dBi: Antenna gain in decibels referenced to the gain of an omnidirectional antenna with 100 percent efficiency.

dBm: Power level in decibels referenced to a level of one milliwatt (0.001 watt), that is, $\text{dBm} = 10 \log_{10} (P/0.001)$ where P is in watts.

dBv: Voltage level in decibels referenced to a level of one volt, that is, $\text{dBv} = 20 \log_{10} (V_1/1)$ where V_1 is in volts.

DECIBEL, power (dB): Ten times the log of the ratio of two power values, that is, $\text{dB} = 10 \log_{10} (P_1/P_2)$.

DECIBEL, voltage (dB): Twenty times the log of the ratio of two voltage values, that is, $\text{dB} = 20 \log_{10} (V_1/V_2)$.

DELAY DISTORTION (PHASE DISTORTION): Distortion occurring in communication channels because of variations in signal propagation speeds at different frequencies. Measured in time relative to a reference frequency.

DELAY MODULATION (DM-M): Method for representing digital data, where a ONE is represented by a mid-bit transition, and a ZERO is represented by a transition at the end of the bit when the next bit is a ZERO and no transition when the next bit is a ONE.

DEMODULATOR: A device to affect the process of demodulation. See also, demodulation.

DEMODULATION: The process of recovery or extraction of the original information signal from the modulated RF signal.

DERANDOMIZER: A device that performs the inverse operation of a randomizer. Recovers data that was previously randomized. Also known as a descrambler.

DETECTION: Determination of the presence of a signal. The process by which a signal corresponding to the modulating signal is obtained from a modulated carrier.

DETECTOR, BALANCED: Demodulator for frequency modulation systems. In one form, the output consists of the rectified difference of the two voltages produced across two resonant circuits, with one circuit being tuned slightly above the carrier frequency and the other slightly below.

DETECTION, LINEAR: The form of detection in which the output voltage is proportional to the voltage of the input wave.

DEVIATION: The algebraic difference between a given value and its corresponding central reference value.

DEVIATION DISTORTION: Distortion in an FM receiver caused by inadequate bandwidth, amplitude modulation rejection, or discriminator linearity.

DEVIATION, PEAK FREQUENCY: The maximum difference between the instantaneous frequency of the modulated signal and the reference carrier frequency.

DEVIATION, PEAK PHASE: The maximum difference between the instantaneous phase of the modulated signal and the reference carrier signal.

DEVIATION RATIO: The ratio of one-half the defined channel peak-to-peak deviation to the discriminator low-pass output filter bandwidth.

DEVIATION, RESIDUAL: Apparent modulation because of noise in the transmitter. Also known as incidental frequency modulation.

DIGITAL-TO-ANALOG CONVERTER (DAC): A device that converts an input binary code into an analog voltage.

DIGITIZE: To assign digital numbers to characters and words according to fixed rules of ordering. To convert from analog to digital form.

DIRECT RECORDING with ac BIAS: A magnetic recording technique employing a high-frequency bias signal which is linearly added to the data signal. The composite signal is then used to drive the record-head segment.

DISCRIMINATOR, FM: An electronic device that operates as a frequency to voltage converter.

DIVERSITY COMBINER: An electronic device that sums the signals from two or more sources.

DIVERSITY RECEPTION: A method of radio reception whereby, in order to minimize the effects of fading, a resultant signal is obtained by combination or selection of two or more sources of received-signal energy which carry the same modulation or intelligence, but which may differ in strength or signal-to-noise ratio. Diversity reception may employ frequency, polarization, time, or space diversity.

DOPPLER EFFECT: A principle of physics that, as the distance between a source of constant frequency and an observer diminishes or increases, the received frequencies are greater or less.

DOPPLER SHIFT: The change in frequency of a system caused by the Doppler effect.

DOWN-CONVERTER: An electronic device that translates a given frequency band to a frequency band with a lower center frequency.

DRIFT: A slow change in either absolute level or slope of an input-output characteristic.

DROPOUT: A momentary loss of signal in a transmission channel; usually RF or magnetic tape in telemetry applications.

DUCTING (RF TRANSMISSION): Confinement of electromagnetic wave propagation to a restricted atmospheric layer by steep gradients in the index of refraction with altitude.

- E -

E_b/N_0 : Ratio of signal energy per bit divided by the noise power spectral density per Hz.

ENHANCED NON-RETURN-TO-ZERO LEVEL (ENRZ-L): Method for representing digital data, trademark of the DATATAPE Division of the Kodak Corporation. The input data NRZ-L bits are collected into separate groups of seven bits. Bits 2, 3, 6, and 7 are inverted, and an 8th bit is added to make the parity odd (odd number of ONES).

ENVELOPE DELAY: A characteristic of communication channels where variations in signal delay with respect to frequency occur across the data channel bandwidth. Also, see delay distortion and phase distortion.

ERROR CORRECTION: The process of correcting bits in error using redundant data bits.

ERROR DETECTION: The process of detecting bit errors.

ERROR MULTIPLICATION: A process in which individual isolated input bit errors cause multiple output bit errors. The degree of multiplication of errors is characteristic of the coding system employed.

EQUALIZATION: A method used to compensate for amplitude and phase distortions occurring in a communication channel. Equalizers are designed to provide the inverse of the channel distortion so that the signal can be recovered in its original form. Also, see distortion.

EXCLUSIVE-OR GATE: The exclusive-OR gate is defined as a two-input device whose output assumes the ONE state, if one and only one input assumes the ONE state.

EYE PATTERN: The pattern that results, as displayed on an oscilloscope, from the superpositioning of ONES and ZEROS in a digital data sequence, when the time base of the oscilloscope is synchronized to the bit rate clock.

- F -

FILTER, BANDPASS: A filter having a single transmission band extending from a frequency higher than zero to a frequency lower than infinity.

FILTER, BANDSTOP: A filter that passes frequencies from zero to a lower cutoff frequency and from a higher cutoff frequency to infinity. Signals at frequencies between the lower and higher cutoff are attenuated. This filter is also called a notch filter or a band-reject filter.

FILTER, CONSTANT AMPLITUDE: A filter that is designed to have a maximally flat amplitude response; a Butterworth filter.

FILTER, CONSTANT DELAY: A filter that is designed to have a maximally flat delay response; a Bessel filter.

FILTER, HIGH-PASS: A filter having a single transmission band extending from some cutoff frequency, not zero, up to infinite frequency.

FILTER, LOW-PASS: A filter having a single transmission band extending from zero to some cutoff frequency, not infinite.

FLAME ATTENUATION: The attenuation of a radio signal as it passes through the ionized gas and particles of the exhaust from a rocket motor.

FLAWS, MAGNETIC TAPE: Regions of a magnetic tape where the density of magnetic particles is much lower than the nominal value. Regions of a magnetic tape that have been physically damaged.

FLUTTER: The undesired frequency changes produced by speed variations of the magnetic tape during recording and reproduction.

FLUX TRANSITION: A 180° change in the flux pattern of a magnetic medium brought about by the reversal of the magnetic poles within the medium.

FLUX TRANSITION DENSITY (LINEAR): The number of flux reversals occurring during a given length of tape (linear dimension in inches or millimeters).

FM DISCRIMINATOR: An electronic device that acts like a frequency-to-voltage converter.

FM/FM (FREQUENCY MODULATION/FREQUENCY MODULATION): Frequency modulation of a carrier by subcarriers which are frequency modulated by information signals.

FORMAT: A predetermined arrangement of characters, fields, lines, punctuation, and page numbers.

FQPSK: Feher's patented quadrature phase shift keying. FQPSK was designed to have essentially constant envelope and therefore minimal or no spectral spreading when amplified by a non-linear amplifier.

FRAME: A set of digital data encompassed within a specified boundary, for example, minor frame, major frame, and data frame. The boundary is marked by a frame synchronization word.

FRAME FORMAT IDENTIFICATION: A word that uniquely identifies which PCM format is currently being transmitted when more than one format is possible.

FRAME OF DATA: A sequence of data bits in which the position of each data bit can be identified by reference to the frame synchronization pattern.

FREQUENCY DEVIATION: In frequency modulation, the difference between the instantaneous frequency of the modulated wave and the unmodulated carrier frequency.

FREQUENCY DEVIATION LIMIT: The upper and lower frequency limits beyond which a subcarrier should not be deviated.

FREQUENCY DIVERSITY: A form of diversity that uses both transmission and reception at more than one frequency.

FREQUENCY DIVISION MULTIPLEXING: A multiplexing technique in which the channel bandwidth is divided into different frequency subchannels. Permits more than one signal source to share the same communication channel.

FREQUENCY DIVISION MULTIPLEX: A system for the transmission of information about two or more quantities (measurands) over a common channel by dividing the frequency band. Amplitude, frequency, or phase modulation of the subcarriers may be employed. A process or device in which each signal channel modulates a separate subcarrier. The subcarriers are spaced in frequency to avoid overlapping of the subcarrier sidebands.

FREQUENCY MODULATION (FM): A method for transmitting information where the amplitude of the information signal is used to vary the frequency of the carrier signal.

FREQUENCY OFFSET: A deviation from the reference frequency. May be static or dynamic; for example, a varying offset or a fixed frequency offset such as occurs when a dc voltage is applied to an FM carrier system.

FREQUENCY RESPONSE: A measure of how effectively a device passes the different frequencies applied to it.

FREQUENCY SHIFT KEYING (FSK): A form of frequency modulation in which the modulating signal shifts the carrier frequency between predetermined values, and the output signal has no phase discontinuity. Commonly, the instantaneous frequency is shifted between two discrete values, termed the Mark and Space frequencies.

- G -

GAIN (AMPLITUDE): An increase in signal amplitude, normally expressed in decibels (dB).

GAP LENGTH (PHYSICAL): The dimension between leading and trailing edges of a record or reproduce head-segment gap measured along a line perpendicular to the leading and trailing edges of the gap.

GAUSSIAN NOISE: Noise whose amplitude is characterized by the normal distribution.

GROUND STATION: A telemetry-receiving, recording, processing and display system. This term is also used to refer to systems which contain a subset of the above functions.

GROUP DELAY: The derivative of radian phase with respect to radian frequency, often called envelope delay.

G/T (RADIO ANTENNAS): The ratio of the maximum power gain to the noise temperature (in °K) of an antenna and its associated receiving system.

GUARD BAND: The unused frequency spaces between subcarriers in FDM systems and between RF carriers. Used to guard against interference.

- H -

HARMONICS: Frequencies that are multiples of a fundamental frequency. Odd harmonics are odd multiples of the fundamental frequency and even harmonics are even multiples of the fundamental frequency.

HARMONIC DISTORTION: The production of harmonic frequencies at the output of a nonlinear device when a sinusoidal signal is applied to the input.

HARMONIC FREQUENCIES: Frequencies that occur at multiples of the fundamental frequency.

HEAD, MAGNETIC: A device that records, reads or erases data on magnetic tape.

HEAD SEGMENT: A single transducer that either records a signal on tape or reproduces a signal previously recorded on tape.

HIGH DENSITY DIGITAL RECORDING (HDDR): Recording of digital data, on a magnetic recording medium, having a linear flux transition density in excess of 15,000 transitions per inch.

HORIZONTALLY POLARIZED WAVE: A linearly polarized wave whose electric field vector is horizontal with respect to the earth's surface.

HYBRID MODULATION: A combination of the modulation methods, PCM/FM, PCM/PM, and FM/FM, used to impress information on a carrier for transmission.

HYSTERESIS (MAGNETIC): The property of a magnetic material that causes the magnetic induction for a given magnetizing force to depend on the previous conditions of magnetization.

HYSTERESIS LOSS (MAGNETIC): The power lost in a magnetic material as a result of magnetic hysteresis.

- I -

INCIDENTAL FM: The short term jitter or undesired FM deviation of a local oscillator. Also known as residual FM.

INSERTION LOSS: The decrease in power delivered to the load when a device is inserted between the source and load.

INTERFERENCE (COUPLING): Interference resulting from signals transferring (coupling) between circuits.

INTERFERENCE (DATA TRANSMISSION): Interference in a signal transmission path is either extraneous power that tends to interfere with the reception of the desired signals or the disturbance of signals, which results.

INTERMODULATION DISTORTION: Distortion brought about by the interaction of two or more frequencies resulting in erroneous information signal transmission.

INTERMEDIATE FREQUENCY (IF): A frequency to which a signal is shifted locally as an intermediate step in transmission or reception.

- J -

JITTER: Information signal variations relative to a reference time position. Variations can be in time, frequency, or phase. These variations may result in erroneous detection of information signals, particularly pulse type systems. Frequency modulation of the bit rate or bit rate clock.

JITTER RATE: Rate or frequency at which the bit rate or bit rate clock is being modulated.

- K -

KILOBITS PER INCH (kb/in): Linear packing density expressed in thousands of bits per linear inch. Usually used in digital magnetic recording.

- L -

L-BAND: A term referring to the band of frequencies between 1000 and 2000 MHz. The telemetry portion of L-band extends from 1435 to 1540 MHz. The frequencies between 1700 and 1850 MHz are frequently referred to as upper L-band signals.

LEFT-HAND POLARIZED WAVE: An elliptically polarized electromagnetic wave in which the rotation of the electric field vector is counterclockwise when looking in the direction of propagation.

LINEARITY: The condition where in the change in the value of one quantity is directly proportional to the change in the value of another quantity. A relationship existing between two quantities such that the change in one quantity is exactly and directly (linearly) proportional to the change in the other quantity.

LOCK: The state of being synchronized in frequency, phase, or motion to another signal or object.

- M -

MAJOR FRAME: The data structure consisting of the smallest number of minor frames which includes at least one sample of each parameter in the format.

MATCHED LOAD: A device used to terminate a transmission line so that all of the incoming energy is absorbed.

MAXIMAL LENGTH SEQUENCE: A pseudo-random sequence of length $2^N - 1$ generated by a shift register of length N.

MILLER CODE: See Delay Modulation.

MILLER SQUARED (M^2): Method for representing digital data where the bit stream to be encoded is divided into data sequences of three types:

Type A: Any number of consecutive logic ONES.

Type B: Two logic ZEROS separated by either no logic ONES or an odd number of ONES, for example, 00, 010, 01110.

Type C: A logic ZERO followed by an even number of logic ONES and terminated by a ZERO not counted as part of the sequence, for example, 011, 01111.

For types A and B, ONES are coded with transitions in the middle of the bit, and consecutive ZEROS have transitions between them. It is the same as for delay modulation; however, in type C sequences the transition in the middle of the final ONE is inhibited.

MINIMUM TRANSITION DENSITY: The minimum number of transitions for a given number of bits for any input bit sequence.

MINOR FRAME: The data structure in time sequence from the beginning of one minor frame synchronization pattern to the beginning of the next minor frame synchronization pattern.

MODULATION INDEX: The modulation index (β) is equal to the peak phase deviation when a single sinusoid angle modulates the carrier,

$$\beta = \Delta\phi$$

For frequency modulation, the modulation index is often expressed as the ratio of the peak frequency deviation to the frequency of the modulating signal,

$$\beta = \Delta f/f_m$$

where Δf is the peak carrier frequency deviation and f_m is the modulation frequency.

MODULATOR: A device that causes some parameter of a carrier signal to vary in step with the modulating signal.

MULTICOUPLER: A device used to interface one antenna to several receivers with gain of one or larger.

MULTIPATH: The phenomenon where signals reach the receiving antenna by two or more separate paths. Can cause echoes or ghosting.

- N -

NOISE: Any unwanted disturbance or spurious signal that modifies the transmitting, indicating, or recording of the desired signal.

NOISE FIGURE: The ratio of total output noise power to output noise power because of noise present at the input of the device, when the input source is at a temperature of 290 °K; usually expressed in dB.

NOISE, FLUCTUATION: Noise whose amplitude is completely random. The error in the output of a demodulator when the signal is larger than the noise.

NOISE, GAUSSIAN: Noise whose amplitude has a normal (Gaussian) distribution.

NOISE, IMPULSE: Noise generated in discrete energy bursts that has a characteristic wave shape of its own.

NOISE LOADING: The process of simulating the sum of many independent modulating signals using one Gaussian noise signal.

NOISE LOADING TEST SET: An electronic device that generates and receives a Gaussian noise signal. It is used to measure the noise floor and intermodulation level of a transmission system.

NOISE, POP: The error in the demodulated output that occurs when the vector sum of the signal plus noise encircles the origin. The instantaneous noise amplitude has to be larger than the instantaneous signal amplitude for this type of noise to occur. Also known as click noise.

NOISE, RANDOM: A signal whose instantaneous amplitude is determined at random and is therefore unpredictable. It contains no periodic frequency components and has a continuous frequency spectrum.

NOISE TEMPERATURE: The temperature of a passive system having an available noise power per unit bandwidth equal to that of the actual terminals. The noise temperature of a simple resistor is the actual temperature of the resistor, while the noise temperature of a diode may be many times the observed absolute temperature. The standard reference temperature T_0 for noise measurements is 290°K.

NOISE, WHITE: Noise whose power is distributed uniformly over all frequencies. Since ideal white noise is an impossibility, bandwidth restrictions must be applied.

NOISE POWER RATIO (NPR): The decibel ratio of the noise power with the baseband fully loaded to the noise power with the baseband fully loaded except for a narrow band around the measurement frequency. All noise powers are measured in a narrow band around the measurement frequency.

NON-RETURN-TO-ZERO LEVEL (NRZ-L): A binary method of representing digital data where a ONE is represented by one level and a ZERO is represented by the other level in a bi-level system. The level does not return to zero between the data pulses.

NORMAL RECORD LEVEL: The input level to an IRIG magnetic tape recorder which produces 1 percent third harmonic distortion with an input frequency equal to 10 percent upper band edge frequency of the recorder/reproducer system.

- O -

ODD PARITY: Bit added to a binary code group that is used to make the number of ONES or ZEROS in a group odd.

OVERHEAD BITS: Extra bits added to a digital sequence of data bits. The extra bits are used to control and/or interpret system response. Overhead bits may also be used for error detection and correction (EDAC).

- P -

PACKING DENSITY, LINEAR: The number of units of useful information contained within a given linear dimension, usually expressed in units per inch or millimeter. The number of binary digit magnetic pulses stored on a tape per linear inch on a single track.

PARALLEL HIGH DENSITY DIGITAL RECORDING (HDDR): Method of recording a digital data sequence, where the data sequence is multiplexed onto more than one recording channel.

PARITY BIT: A bit added to a binary code group and is used to make the number of ONES or ZEROS even or odd in that group.

P-BAND: The band of frequencies between 215 and 320 MHz used primarily as a common frequency band into which L-band and S-band telemetry signals are downconverted in some telemetry-receiving stations. A portion of this band was used for telemetry transmission before 1970. Some programs continue to use this band on a waiver basis.

PCM, PARALLEL: A PCM technique in which pulses are transmitted simultaneously over parallel channels. The technique is often encountered in magnetic tape recording.

PCM, SERIAL: PCM transmission in which a single data channel is used and the pulse code signals are received in sequential order.

PHASE DISTORTION (DELAY DISTORTION): Distortion occurring in communication channels because of variations in signal propagation speeds at different frequencies. Measured in time relative to a reference frequency.

PHASE EQUALIZATION: The process of reducing phase distortion by the introduction of networks to compensate for the differences in delay at various frequencies.

PHASE JITTER: A dynamic variation of signal phase about some phase reference point.

PHASE SHIFT KEYING (PSK): Modulation technique where the modulated carrier is shifted either $+90^\circ$ or -90° relative to the reference carrier. Usually accomplished by amplitude modulation of the carrier by ± 1 .

POLARITY: Having two opposite states such as positive and negative voltages or north and south poles.

POLARIZATION DIVERSITY (RECEPTION): That form of diversity reception that uses receiving antennas whose polarizations are mutually orthogonal (usually vertical and horizontal or left-hand circular and right-hand circular).

PREAMPLIFIER: An amplifier connected to a low level signal source to present suitable input and output impedances and provide gain so that the signal may be further processed without appreciable degradation in the signal-to-noise ratio.

PREEMPHASIS: A process in a system designed to emphasize the amplitude of some frequency components with respect to the amplitude of others in order to improve the signal-to-noise ratio or reduce distortion.

PREMODULATION FILTERING: The filtering of a signal prior to carrier modulation. The effect is to reduce the energy contained in the sidebands of the modulated carrier.

PRINT-THROUGH (MAGNETIC TAPE): The inadvertent magnetization of a layer of magnetic tape by an adjacent layer.

PROPAGATION DELAY: The necessary time required for a signal to be transmitted from one point to another.

PROPAGATION LOSS (FREE SPACE): The loss of energy caused by the "spreading" of an electromagnetic wave as it travels through space. This loss (dB) can be calculated using

$$20 \log_{10} (4\pi D/\lambda),$$

where

λ is the wavelength of the transmitted signal

D is the distance between the transmitter and receiver.

PROPORTIONAL BANDWIDTH: In a proportional bandwidth system, the bandwidth of each channel is proportional to its center frequency. The maximum channel deviation is the product of the deviation value in percent divided by 100 and the center frequency of the channel.

PSEUDO-RANDOM PATTERN: A non-random pattern having statistical properties resembling a random pattern.

PSEUDO-RANDOM SEQUENCE (PRS): A non-random digital data sequence having statistical properties resembling a random digital sequence.

PSEUDO-RANDOM SEQUENCE MODULATED NRZ-L: Method for representing digital data where the NRZ-L bit sequence is modulo-2 summed with a pseudo-random sequence (PRS).

PULSE AMPLITUDE MODULATION/FREQUENCY MODULATION (PAM/FM): Frequency modulation of a carrier by pulses, the amplitude of which contains the information to be transmitted.

PULSE AVERAGING DEMODULATOR: A type of FM demodulator in which a constant area pulse is generated for each zero crossing (can also use only positive or negative going zero crossings). The pulse train is low-pass filtered to produce a voltage which is proportional to the input frequency.

PULSE CODE MODULATION (PCM): Time division multiplexing (TDM) technique in which samples of data are represented in binary form by a group of discrete pulses.

PULSE CODE MODULATION/FREQUENCY MODULATION (PCM/FM): Frequency modulation of a carrier by pulse code modulation (PCM) information.

PULSE CODE MODULATION/FREQUENCY MODULATION/FREQUENCY MODULATION (PCM/FM/FM): Frequency modulation of a carrier by subcarriers that are frequency modulated by pulse code modulated information.

PULSE CODE MODULATION/PHASE MODULATION (PCM/PM): Phase modulation of a carrier by PCM information.

- Q -

N/A

- R -

RADIATION LOSS: The part of the transmission loss because of radiation of radio frequency (RF) power.

RANDOMIZE: The process of converting a regular signal into a random signal (also known as scrambling).

RANDOMIZED NON-RETURN-TO-ZERO: A coding technique used to convert a bit stream into a bit stream with properties similar to random data. The IRIG randomizer adds (modulo 2) the input bit stream and the output bit stream delayed by 14 and 15 bits to produce the new output bit. Frequently used for magnetic recording. The derandomizer is self-synchronizing.

RECORD LEVEL, NORMAL: The input level to an IRIG magnetic tape recorder which produces 1 percent third harmonic distortion with an input frequency equal to 10 percent of the upper bandedge frequency of the recorder/reproducer system.

REGENERATED CLOCK: A clock signal that has been generated or reconstructed from a digital data sequence. A reconstructed clock.

RELAY: A radio station (ground or airborne) used for the reception and the retransmission of the signals from another radio station.

RELAY POD: An airborne receiver-transmitter combination which receives a signal, performs a frequency translation and retransmits it. Used in telemetry systems to relay signals from test vehicles to telemetry ground stations.

REPEATER STATION: An intermediate point in a transmission system where signals are received, amplified or reshaped, and retransmitted.

RE-SYNCHRONIZATION: A reestablished synchronous operation that after having lost it, returned it to being in step or in phase again.

RETURN-TO-ZERO (RZ): PCM code in which the encoded signal is at 0.0 volts for the second half of each encoded bit.

REVERSE PLAYBACK: Reproduction of previously recorded data in a direction of tape travel which is the reverse of the direction the data was recorded.

RF TRANSMISSION: Transmission of data from one site to another using a radio frequency carrier.

RIGHT-HAND POLARIZED WAVE: An elliptically polarized electromagnetic wave in which the rotation of the electric field vector is clockwise when looking in the direction of propagation.

- S -

SAMPLED SIGNAL: The sequence of values of a signal taken at discrete instants.

SATURATION: A condition where an increase in input signal amplitude does not produce an increase in output amplitude.

S-BAND: The range of frequencies between 2000 and 4000 MHz. The telemetry portions of this band are 2200 to 2300 MHz and 2310 to 2390 MHz.

SECOND HARMONIC DISTORTION: The ratio of the rms voltage at twice a fundamental frequency to the rms voltage at the fundamental frequency, usually expressed in percent or dB.

SENSITIVITY, RECEIVER: That characteristic which determines the minimum strength of signal input capable of causing a desired value of signal output.

SERVO-CONTROL (RECORDER/REPRODUCER): The use of a reference signal to control the playback speed of the recorder/reproducer.

SERIAL HIGH DENSITY DIGITAL RECORDING (HDDR): Method of recording a digital data sequence, having a flux transition density in excess of 15,000 transitions per inch, where the data sequence is recorded on one recording channel.

SHEDDING, TAPE: Loss of magnetic coating from tape during operation on a tape transport.

SHIFT REGISTER: A logic network comprised of flip-flops connected in series. A binary state applied to the first register input can be shifted through the entire series of registers. A delay network.

SIDE LOBE (ANTENNA PATTERN): A radiation lobe in any direction other than that of the intended lobe. **NOTE:** When the intended lobe is not specified, it shall be taken to be the major lobe.

SIGNAL CONDITIONING: Conditioning performed on an information signal to provide the performance characteristics required for certain types of data transmission.

SIGNAL-TO-NOISE RATIO (SNR): The relative power (or voltage) levels of signal and noise on a communications line, often expressed in dB. This term is usually expressed in terms of peak values in the case of impulse noise and in terms of root mean square (rms) values in the case of Gaussian noise.

SIGNATURE RECORDING: The recording of a signal which can be used to align the reproduce machine to the recording machine.

SNR MARGIN: Excess SNR over that required to achieve a given data quality for a given communication channel.

SPACE DIVERSITY RECEPTION: That form of diversity reception that uses receiving antennas placed in different locations.

SPECTRUM: The distribution of the amplitude, and sometimes phase, of the components of a signal as a function of frequency.

STANDARD RECORD LEVEL (RECORDERS/REPRODUCERS): The input level to an IRIG magnetic tape recorder which produces 1 percent third harmonic distortion with an input frequency equal to 10 percent of the upper band edge frequency of the recorder/reproducer system.

SUBCOMMUTATION: The process of sampling a parameter at a submultiple of the minor frame rate.

SUPERCOMMUTATION: The process of sampling a parameter at a rate which is a multiple of the minor frame rate.

SUPERHETERODYNE: The process of translating a high frequency to a lower frequency.

SYNCHRONIZATION: The maintenance of one operation in step with another, also called sync.

SYNCHRONIZATION WORD: Overhead bits inserted into a frame of data which are used to demultiplex the data bits.

SYNCHRONOUS: In step or in phase as applied to two or more digital data sequences; for example, two digital sequences which are synchronous with each other. A term in which the performance of a sequence of operations is controlled by equally spaced clock signals or pulses.

- T -

TACH-SERVO (RECORDER/REPRODUCER): The process of controlling the speed of the playback machine by its own internal speed reference.

TAPE FLAWS: Defects in the physical characteristics of a magnetic tape, for example, irregularities in oxide coating, edge cutting, base material, or backing material. These irregularities may cause dropouts, amplitude fluctuations, and poor tracking.

TAPE SERVO (RECORDER/REPRODUCER): The process of controlling the speed of the playback machine by synchronizing it to a speed control signal recorded on the tape by the recording machine.

TELEMETRY: An electrical system for measuring a quantity, transmitting the result to a different location, and then, indicating or recording the quantity measured. Interpretation is not part of the telemetry process.

THERMAL NOISE: A type of electromagnetic noise produced in conductors or electronic circuitry, whose power is proportional to temperature.

THIRD HARMONIC DISTORTION: The ratio of the rms voltage at three times the fundamental frequency to the rms voltage at the fundamental frequency, usually expressed in percent or dB.

THRESHOLD, FM: The smallest value of SNR (or CNR) at the input to the demodulator such that a small change in input SNR produces an equal (or smaller) change in output SNR.

TIME DIVERSITY RECEPTION: That form of diversity reception that uses multiple transmissions that are separated in time.

TIME DIVERSITY TRANSMISSION: That form of diversity transmission that uses multiple transmissions separated in time.

TIME DIVISION MULTIPLEXING (TDM): A method for transmitting two or more quantities of source information (measurands) over a common channel by dividing available time intervals among the information signals to form a composite pulse train.

TRACK (RECORDER): One channel of a recorder/reproducer system.

TRACKING ANTENNA: An antenna that moves the position of its major lobe so that a selected moving target is contained within the major lobe.

TRANSDUCER: A device by means of which energy may flow from one or more transmission systems to one or more other transmission systems. The energy may be of any form such as electrical, mechanical, or acoustical.

TRANSITION DENSITY PROBABILITY: The actual number of state changes from "high" to "low" or "low" to "high" divided by the number of bits during a given time interval.

- U -

UPCONVERTER: An electronic device for translating a frequency band to a frequency band with a higher center frequency.

- V -

VERTICALLY POLARIZED WAVE: A linearly polarized electromagnetic wave whose electric field vector is vertical with respect to the earth's surface.

VIDEO: The demodulated output of a telemetry receiver. A television or radar signal used to drive a cathode-ray tube.

- W -

WAVE: A disturbance that is a function of time or space or both. A disturbance propagated in a medium or through space. Disturbance indicates mechanical, voltage, current, electric field strength, or temperature displacement.

WAVE ANALYZER: An electronic instrument for measuring the amplitude and frequency of various components of a complex signal.

WHITE NOISE: Noise that has a constant power spectral density over a specified bandwidth.

INDEX

- amplifier
 - low noise.....2-201
 - non-linear.....2-85
- attenuation
 - atmospheric2-172
 - final IF filter2-15
 - flame4-15
 - plume2-172
 - R-C filter.....2-29
- Attenuation
 - atmospheric2-177
 - plume2-177
- azimuth4-17
- bandwidth2-28
 - biphase PCM/FM 2-41, 2-62
 - demodulator loop.....2-55
 - demodulator loop & video.....2-55
 - NRZ PAM2-98
 - NRZ PAM/FM2-113
 - NRZ PCM/PM.....2-54
 - peak deviation.....2-63
 - receiver IF.....2-55
 - RF spectra.....2-77
- bias recording.....4-21
- biphase PCM/FM
 - advantages2-37
 - disadvantages.....2-37
- Biphase PCM/FM2-37
- bit error rate
 - IF SNR.....2-21
 - IF/SNR influence.....2-8
 - NRZ PCM/PM.....2-48
 - tuning errors2-18
- bit synchronizer
 - loop bandwidth.....2-63
 - NRZ PCM/PM.....2-59
 - biphase.....4-37
- crosstalk2-100
- constant bandwidth2-119
- CPM.....2-87, 2-93, 2-94
- crossplay1-3
- crosstalk2-112
- Crosstalk2-100
- data multiplexing1-2
- Data Quality Monitoring4-50
- derandomizer4-43
- diversity reception4-59
- ducting.....2-177
- decommutator.....2-98
- deviation
 - peak4-48, 4-51
- Differential encoding.....2-92
- discriminator.....1-6, 2-119, 2-121
- diversity combiner..2-177, 2-221, 4-8, 4-11, 4-12
- diversity reception2-176
- downconverter2-18, 4-7, 4-30
- ducting.....2-172
- equalization4-21, 4-37
- eye pattern2-64, 2-73, 4-44, 4-51
- flutter2-141
- frequency modulation.....2-1
- filter2-8, 2-15, 2-19
 - techniques1-5
- flutter2-100, 2-141
- flutter9
- FM
 - noise characteristics2-183
- FM/FM2-1, 2-11, 2-119, 2-124
- FQPSK-B2-84, 2-85, 2-86, 2-89, 2-92
- FQPSK-JR.....2-82, 2-83, 2-84, 2-85, 2-87, 2-92
- frequency division multiplex.....2-1, 3-1
- frequency modulation.2-8, 2-37, 2-87, 2-95, 2-183
- G/T2-177, 4-1, 4-2
- gap
 - head segment.....4-17
 - reproduce gap loss.....4-21
- GPS Compatibility2-201
- ground station.....3-4
- head
 - magnetic recording.....4-16
- High Density Digital Recording.....4-37
- Hybrid systems2-167
- incidental frequency modulation2-11
- Link Analysis2-172
- magnetic tape recording4-59

| | |
|---------------------------------------|---|
| multicoupler..... | 4-5 |
| multipath..... | 2-176 |
| modulation index..... | 2-92, 2-150, 2-154 |
| multipath..... | 2-172, 4-15 |
| noise | |
| pop..... | 2-2 |
| noise | |
| fluctuation..... | 2-12 |
| FM demodulator..... | 2-1 |
| out-of-band..... | 2-19 |
| pop..... | 2-11 |
| SNR..... | 2-98 |
| white..... | 2-29 |
| noise power ratio..... | 2-160 |
| non-return-to-zero | |
| PCM summary links..... | 2-1 |
| normal record level..... | 2-141 |
| NRZ PCM/FM..... | 2-8 |
| NRZ PCM/FM..... | 2-35, 2-36 |
| NRZ PCM/FM..... | 2-17, 2-30, 2-171, 2-216 |
| advantages..... | 2-37 |
| bandwidth..... | 4-49 |
| disadvantages..... | 2-37 |
| peak deviation..... | 2-11 |
| RF spectra..... | 2-28 |
| packing density..... | 2-208, 4-41 |
| PAM..... | 2-95, 2-101, 2-102, 2-103, 2-104, 2-105, 2-106, 2-107, 2-108, 2-109, 2-110, 2-111, 2-113, 2-114, 2-115, 2-117 |
| NRZ..... | 2-97 |
| receiver..... | 2-112 |
| SNR..... | 2-98 |
| phase shift keying..... | 2-82 |
| polarization diversity..... | 2-176, 4-8, 4-12 |
| preemphasis..... | 2-142 |
| premodulation filtering | |
| NRZ PCM/FM..... | 2-2 |
| preamplifier | |
| purpose..... | 4-5 |
| premodulation filtering..... | 1-2 |
| signal energy..... | 2-54 |
| Premodulation filtering..... | 2-1 |
| Premodulation Filtering | |
| biphase PCM/FM..... | 2-3 |
| biphase PCM/PM..... | 2-5 |
| NRZ PCM/PM..... | 2-4 |
| propagation loss..... | 2-176 |
| proportional bandwidth..... | 2-119 |
| pulse amplitude modulation..... | 2-1 |
| RCC..... | xix |
| Receiver IF Bandwidth | |
| biphase PCM/FM..... | 2-3 |
| biphase PCM/PM..... | 2-5 |
| NRZ PCM/FM..... | 2-2 |
| NRZ PCM/PM..... | 2-4, 2-6, 2-7 |
| receiver video filter | |
| NRZ PAM/FM..... | 2-112 |
| selection..... | 2-21 |
| receiving antenna..... | 4-3 |
| receiving system | |
| characterization..... | 4-1 |
| recorder/reproducer | |
| alignment..... | 4-18 |
| predetection..... | 4-17 |
| recorder/reproducer system..... | 4-16 |
| IRIG considerations..... | 4-16 |
| recording..... | 1-2 |
| techniques..... | 2-18 |
| Relay Systems..... | 2-180 |
| Secretariat..... | xix |
| signal conditioning..... | 3-1, 4-17 |
| Signal Spacing..... | 2-208 |
| SNR..... | 2-2, 2-3, 2-4, 2-5, 2-6, 2-7 |
| intermediate frequency SNR..... | 2-8 |
| SNR (signal-to-noise ratio)..... | xxv |
| SOQPSK-TG..... | 2-89, 2-90, 2-91, 2-92, 2-94 |
| signal conditioning..... | 3-1 |
| Synchronizers and Discriminators | |
| PCM bit..... | 4-44 |
| telemetry ground station | |
| parameters..... | 4-48 |
| telemetry receiver..... | 4-8 |
| telemetry system | |
| definition..... | 1-3 |
| threshold, FM..... | 2-98 |
| time division multiplexing (TDM)..... | 3-1 |
| Time division multiplexing (TDM)..... | 4-50 |
| transducer..... | 1-2, 1-5, 3-1 |
| transmitting system | |
| function..... | 3-1 |
| guidelines..... | 3-2 |

