

DEPARTMENT OF THE ARMY
U.S. Army Corps of Engineers
Washington, DC 20314-1000

EP 1110-3-2

CEMP-ET

Pamphlet
No. 1110-3-2

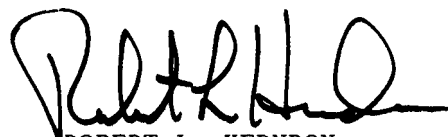
31 December 1990

Engineering and Design
ELECTROMAGNETIC PULSE (EMP) AND TEMPEST PROTECTION FOR FACILITIES

1. Purpose. This pamphlet provides unclassified engineering and design information about protecting fixed ground facilities against the effects of an electromagnetic pulse (EMP) produced by a nuclear explosion. It also provides unclassified engineering and design information about satisfying TEMPEST requirements.
2. Applicability. This pamphlet applies to all HQUSACE/OCE elements, major subordinate commands, districts, laboratories, and field operating activities (FOA) having military construction and design responsibilities.
3. Discussion. The enclosed material constitutes a general reference work on the specialized subject of electromagnetic pulse (EMP) and TEMPEST protection. It was assembled over several years by our Construction Engineering Research Laboratory. The designer who is interested in the theory behind the design will find this material useful. The designer will also find information on aspects of the subject not normally part of the design effort.

FOR THE COMMANDER:

Encl



ROBERT L. HERNDON
Colonel, Corps of Engineers
Chief of Staff

EP 1110-3-2
31 Dec 90

ELECTROMAGNETIC PULSE (EMP) AND TEMPEST PROTECTION FOR FACILITIES

TABLE OF CONTENTS

	<u>Paragraph</u>	<u>Page</u>
CHAPTER 1. INTRODUCTION		
Scope.....	1-1	1-1
Application.....	1-2	1-1
References.....	1-3	1-1
Background.....	1-4	1-2
Pamphlet organization.....	1-5	1-2
CHAPTER 2. EMP ENVIRONMENT		
Outline.....	2-1	2-1
HEMP: detailed discussion.....	2-2	2-2
Other EMP environments.....	2-3	2-5
Environment-to-facility coupling.....	2-4	2-9
Equipment susceptibility.....	2-5	2-16
Cited references.....	2-6	2-19
Uncited references.....	2-7	2-20
CHAPTER 3. EMP HARDENING CONCEPTS FOR FACILITIES		
Outline.....	3-1	3-1
Discussion of general concepts.....	3-2	3-1
Description of HEMP hardening concepts.....	3-3	3-4
Cited reference.....	3-4	3-10
Uncited references.....	3-5	3-10
CHAPTER 4. SYSTEM ENGINEERING REQUIREMENTS		
Outline.....	4-1	4-1
Standards and specifications.....	4-2	4-1
Electromagnetic integration.....	4-3	4-2
HEMP and lightning protection integration.....	4-4	4-2
HEMP/TEMPEST and electromagnetic integration....	4-5	4-4
Environmental requirements.....	4-6	4-5
Cited references.....	4-7	4-6

EP 1110-3-2
31 Dec 90

	<u>Paragraph</u>	<u>Page</u>
CHAPTER 5. FACILITY DESIGN		
Outline.....	5-1	5-1
Theoretical approach to shielding.....	5-2	5-5
Shield design methodology.....	5-3	5-6
Solid shields.....	5-4	5-10
Shielded enclosures.....	5-5	5-20
Mesh and perforated type shields.....	5-6	5-21
Layered shields.....	5-7	5-27
Reinforcement steel (rebar).....	5-8	5-27
Earth cover electromagnetic wave attenuation....	5-9	5-30
Shield joints and seams.....	5-10	5-31
Internal cable and connectors.....	5-11	5-35
Conduit and conduit connections.....	5-12	5-38
Terminal protection for electrical penetrations.	5-13	5-43
Apertures.....	5-14	5-52
Utility penetrations.....	5-15	5-55
Bonding.....	5-16	5-55
Grounding.....	5-17	5-61
Cited references.....	5-18	5-64
Uncited references.....	5-19	5-67
CHAPTER 6. EMP AND TEMPEST TESTING REQUIREMENTS		
Outline.....	6-1	6-1
Introduction.....	6-2	6-3
Testing requirements versus facility mission...	6-3	6-4
Susceptibility testing.....	6-4	6-4
Quality assurance testing.....	6-5	6-6
Acceptance testing.....	6-6	6-7
Hardness assessment and validation testing.....	6-7	6-9
Life-cycle testing.....	6-8	6-10
Test methodology.....	6-9	6-11
Free-field illuminators.....	6-10	6-12
Current injection testing.....	6-11	6-17
Shielding effectiveness testing.....	6-12	6-27
Bonding impedance measurements.....	6-13	6-34
Cited references.....	6-14	6-35
Uncited references.....	6-15	6-36

EP 1110-3-2
31 Dec 90

	<u>Paragraph</u>	<u>Page</u>
CHAPTER 7. PROTECTION MAINTENANCE AND SURVEILLANCE		
Outline.....	7-1	7-1
Introduction.....	7-2	7-2
Facility life cycle environment.....	7-3	7-2
Hardening shielding elements.....	7-4	7-3
Impact of hardness maintenance on facility design.....	7-5	7-4
Hardness maintenance program structure.....	7-6	7-7
Hardness surveillance (HS) activities.....	7-7	7-10
Cited references.....	7-8	7-13
CHAPTER 8. EMP AND TEMPEST RISKS		
Outline.....	8-1	8-1
Introduction.....	8-2	8-2
EMP environment--overview.....	8-3	8-2
Comparison of HEMP and lightning.....	8-4	8-5
TEMPEST risks.....	8-5	8-5
Cited references.....	8-6	8-10
CHAPTER 9. EMP AND TEMPEST PROTECTION CONCEPTS		
Outline.....	9-1	9-1
Introduction.....	9-2	9-1
TEMPEST requirement in relation to HEMP.....	9-3	9-4
Generic facility hardening.....	9-4	9-5
CHAPTER 10. SYSTEMS INTEGRATION		
Outline.....	10-1	10-1
Introduction.....	10-2	10-1
Protection system integration.....	10-3	10-2
Internal systems.....	10-4	10-2
Environmental systems.....	10-5	10-2
General integration.....	10-6	10-3
CHAPTER 11. DESIGN AND SPECIFICATION PROCESS		
Outline.....	11-1	11-1
Introduction.....	11-2	11-2
Design approach.....	11-3	11-2
Typical design process.....	11-4	11-3
General shield design problem areas.....	11-5	11-23

EP 1110-3-2
31 Dec 90

CHAPTER 12. TEMPEST-SHIELDED FACILITIES

Outline.....	12-1	12-1
Introduction.....	12-2	12-2
Design criteria for 50-decibel facilities.....	12-3	12-2
RF shield design for 50-decibel facilities.....	12-4	12-3
Penetration protection devices.....	12-5	12-10
Cited references.....	12-6	12-11
Uncited reference.....	12-7	12-11

LIST OF FIGURES

Figure 2-1.	The Compton process.....	2-25
2-2.	(Not used.)	
2-3.	Variations in high-altitude EMP peak electric field strength as a function of direction and distance from surface zero.....	2-27
2-4.	HEMP waveform.....	2-28
2-5.	Qualitative time domain example of HEMP.....	2-29
2-6.	Qualitative frequency domain example of HEMP.....	2-30
2-7.	Surface-burst EMP showing source region and radiated region.....	2-31
2-8.	Overview of surface-burst EMP.....	2-32
2-9.	Radiated vertical electric field--large surface burst.....	2-33
2-10.	Air-burst EMP--source region.....	2-34
2-11.	Air-burst EMP--radiated region.....	2-35
2-12.	Three modes of penetration and coupling into shielded enclosures.....	2-36
2-13.	Magnetic shielding effectiveness of an enclosure with solid walls and an enclosure with rebar.....	2-37
2-14.	Magnetic shielding effectiveness of an ideal enclosure and an enclosure with openings.....	2-38
2-15.	Ground-based facilities--unintentional antennas.....	2-39
2-16.	EMP coupling to facility penetrations.....	2-40
2-17.	Two mechanisms by which EMP couples to conductors.....	2-41
2-18.	Equivalent circuit for a small electric dipole.....	2-42
2-19.	Equivalent circuit for a small loop (magnetic dipole).....	2-43
2-20.	Modeling example--microwave tower and equivalent fat cylindrical monopole.....	2-44
2-21.	Shielded cables and transfer impedance.....	2-45

LIST OF FIGURES (continued)

	<u>Page</u>
Figure 2-22.	Transmission line coupling..... 2-46
2-23.	Aerial conductors: effect of conductor length..... 2-47
2-24.	Buried conductors: effect of burial depth..... 2-48
2-25.	Ringings..... 2-49
2-26.	Typical internal signal cable distribution diagram..... 2-50
2-27.	Intrasite cables..... 2-51
2-28.	EMP system interaction..... 2-52
2-29.	Energy level ranges, in joules, that damage various components..... 2-53
2-30.	Examples of transient upset..... 2-54
2-31.	Range of pulse power damage constants for representative transistors..... 2-55
2-32.	Range of pulse power damage constants for representative semiconductors..... 2-56
3-1.	Building examples showing three concepts for critical equipment protection..... 3-11
3-2.	Zonal shielding concept..... 3-12
3-3.	Underground facility with four zones..... 3-13
3-4.	Zonal shielding concept with steel-reinforced concrete as shield 1..... 3-14
3-5.	Shielded enclosure: cable entry vault..... 3-15
3-6.	Optical fiber shield penetration..... 3-16
4-1.	Processes and currents occurring in a flash to ground..... 4-12
4-2.	EMP and lightning comparison..... 4-13
4-3.	Sample power line surge voltage as a function of distance from stroke to line..... 4-14
4-4.	Typical spectrum of lightning radiated E-field..... 4-15
4-5.	Average radiated and static fields for lightning..... 4-16
5-1.	Transmission line model of shielding..... 5-97
5-2.	Correction factor in correction term for internal reflections..... 5-98
5-3.	Shield absorption loss nomograph..... 5-99
5-4.	Nomograph for determining magnetic field reflection loss..... 5-100
5-5.	Nomograph for determining electric field reflection loss..... 5-101
5-6.	Nomograph for determining plane wave reflection loss..... 5-102
5-7.	Chart for computing K for magnetic field secondary reflection loss..... 5-103

EP 1110-3-2
31 Dec 90

LIST OF FIGURES (continued)

	<u>Page</u>
Figure 5-8. Chart for computing secondary losses for magnetic fields. X.....	5-104
5-9. Absorption loss for steel and copper shields at 30 hertz to 10,000 megahertz.....	5-105
5-10. Absorption loss for copper and iron, in decibels per mil. X.....	5-106
5-11. Shielding effectiveness in electric, magnetic, and plane wave fields of copper shields (7 mils thick) for signal sources 165 feet from the shield. X.....	5-107
5-12. Shielding effectiveness in electric, magnetic, and plane wave fields of steel shield (1 mil thick) for signal sources 165 feet from the shield. X.....	5-108
5-13. Shielding effectiveness in electric, magnetic, and plane wave fields of steel shield (50 mils thick) for signal sources 165 feet from the shield. X.....	5-109
5-14. Minimum shielding effectiveness of low-carbon steel walls. X.....	5-110
5-15. Performance characteristics of typical commercial shielded enclosures. X.....	5-111
5-16. Mean shielding effectiveness for all test points for the June 1980 test. X.....	5-112
5-17. (Not used.)	
5-18. Aperture shielding. X.....	5-114
5-19. (Not used.)	
5-20. (Not used.)	
5-21. (Not used.)	
5-22. Attenuation--rectangular waveguide.....	5-119
5-23. Attenuation--circular waveguide.....	5-120
5-24. Air impedance of perforated metal and honeycomb.....	5-121
5-25. Air impedance of copper and nickel mesh.....	5-122
5-26. (Not used.)	
5-27. Center area attenuation of 5-meter-high, single-course reinforcing steel room.....	5-124
5-28. Center area attenuation of 10-meter-high, single-course reinforcing steel room.....	5-125
5-29. Correction curves for various rebar diameters and spacings using single-course rebar construction. X.....	5-126
5-30. Shielding degradation versus distance from wall.....	5-127
5-31. Shielding effectiveness of reinforcement steel.....	5-128
5-32. Reinforcement steel welding practice.....	5-129

LIST OF FIGURES (continued)

	<u>Page</u>
Figure 5-33. Schematic presentation--reinforcement steel shield.....	5-130
5-34. Weld joints for sheet steel shields.....	5-131
5-35. Bolted joints for metallic shields.....	5-132
5-36. Shielding effectiveness for bolted joints.....	5-133
5-37. Influence of screw spacing on shielding effectiveness.....	5-134
5-38. Gasket deflection limits (in inches).....	5-135
5-39. Typical mounting techniques for RF gaskets.....	5-136
5-40. Improper gasket application.....	5-137
5-41. EMI shielded door seam (mesh gasket).....	5-138
5-42. EMI shielded door seam ("oval" spiral gasket).....	5-139
5-43. EMI shielded door seam (fingerstock).....	5-140
5-44. Shielding effectiveness and transfer impedance.....	5-141
5-45. A braided-shield coaxial cable.....	5-142
5-46. Cable shielding effectiveness with number of braid layers.....	5-143
5-47. Lossy conductor construction.....	5-144
5-48. Attenuation of HEMP interference propagating on lossy-wrapped conductors.....	5-145
5-49. Induction loop area for twisted pair cables.....	5-146
5-50. Experiments with shielded twisted pair cabling.....	5-147
5-51. Construction of some popular coaxial connectors.....	5-148
5-52. Contact resistance of conductive coatings on aluminum.....	5-149
5-53. Shielding effectiveness of connectors with various finishes.....	5-150
5-54. Effect of tightening torque on shielding effectiveness during vibration.....	5-151
5-55. Effect of added spring fingers on shielding effectiveness.....	5-152
5-56. Effect of adding shielding gaskets on connector shielding effectiveness.....	5-153
5-57. Normalized transfer impedance for solid cylindrical shields.....	5-154
5-58. Magnitude of the transfer impedance of rigid steel conduit.....	5-155
5-59. Flaw impedance (Z_F) of typical coupling.....	5-156
5-60. Diffusion signal for 1-inch galvanized steel conduit showing sense wire voltage.....	5-157
5-61. Flaw impedance (Z_F) of 0.038-millimeter (0.015-inch) wall flex-joint with and without copper strap.....	5-158

EP 1110-3-2
31 Dec 90

LIST OF FIGURES (continued)

	<u>Page</u>
Figure 5-62. Flaw impedance (Z_F) of 0.76-millimeter (0.03-inch) wall flex-joint with and without copper strap.....	5-159
5-63. Experimental HEMP hardened union.....	5-160
5-64. Type C conduit body.....	5-161
5-65. Machined conduit body cover for HEMP hardening.....	5-162
5-66. "Wrap-around" junction box cover.....	5-163
5-67. (Not used.)	
5-68. (Not used.)	
5-69. (Not used.)	
5-70. (Not used.)	
5-71. The four basic filter classes.....	5-168
5-72. Ferrite bead on wire and ferrite bead equiv- alent circuit.....	5-169
5-73. Filter pin connector design.....	5-170
5-74. Shunt and series transformer wiring configuration.....	5-171
5-75. Typical shielded door closures.....	5-172
5-76. Emergency escape hatch configuration.....	5-174
5-77. Typical welded screen installation over a ventilation aperture.....	5-175
5-78. Typical clamped screen installation over a ventilation aperture.....	5-176
5-79. Honeycomb material for shielding air vents.....	5-177
5-80. Waveguide attenuation as a function of waveguide dimensions.....	5-178
5-81. Air vent HEMP protection design.....	5-179
5-82. Conduit or metal pipe penetration design.....	5-180
5-83. HEMP protection for waveguide entry.....	5-181
5-84. Plastic pipe termination practices.....	5-182
5-85. Theoretical attenuation of the TE_{11} mode for a 1.5-inch (3.8-centimeter) internal diameter pipe with distilled water for various loss tangents.....	5-184
5-86. Cutoff frequency versus relative dielectric constant for various pipe diameters.....	5-185
5-87. Effects of poor bonding on the performance of a power line filter.....	5-186
5-88. Bolted bond between flat bars.....	5-187
5-89. Bracket installation (bolt).....	5-188
5-90. Bonding of connector to mounting surface.....	5-189
5-91. Bolting of bonding jumpers to flat surface.....	5-190
5-92. Bonding to rigid conduit.....	5-191
5-93. Equivalent circuit for bonding strap.....	5-192

LIST OF FIGURES (continued)

	<u>Page</u>
Figure 5-94. True equivalent circuit of a bonded system.....	5-193
5-95. Techniques for protecting bonds between dissimilar metals.....	5-194
5-96. Zonal grounding.....	5-195
5-97. Minimum earth electrode system configuration for rectangular-shaped facility.....	5-196
5-98. Electrode configuration for irregular-shaped facility.....	5-197
5-99. Current path on zonal boundaries.....	5-198
5-100. Typical hybrid ground configuration.....	5-199
5-101. Typical ground configurations for HEMP protection.....	5-200
6-1. Bounded wave simulators.....	6-43
6-2. Pulsed radiated wave simulators.....	6-44
6-3. Continuous wave testing--CW test configuration.....	6-46
6-4. Direct current injection testing.....	6-47
6-5. Inductive current injection testing.....	6-48
6-6. Direct drive test for penetrating conductor (conceptual sketch).....	6-49
6-7. Transfer impedance/admittance test setup.....	6-50
6-8. Alternative demonstration and test methods.....	6-51
6-9. Response characteristic measurement.....	6-52
6-10. Standard circuit for measuring S parameters.....	6-53
6-11. Response measurement.....	6-54
6-12. HEMP stress test.....	6-55
6-13. TPD power attenuation test.....	6-56
6-14. Alternative power attenuation test using simulated subsystem impedance.....	6-57
6-15. Static breakdown voltage measurement.....	6-58
6-16. Small-loop-to-small-loop test setup.....	6-59
6-17. Proposed measurement points for small-loop test.....	6-60
6-18. Test setup for Helmholtz coil field generation.....	6-61
6-19. Parallel strip line technique.....	6-62
6-20. Attenuation measurement--high-impedance electric field.....	6-63
6-21. Attenuation test for plane waves (wave impedance = 377 ohms).....	6-64
6-22. Parallel plate line.....	6-65
6-23. Sweep frequency bonding measurement system.....	6-66
7-1. Effect of hardening approach on subsystem design.....	7-15
7-2. Interaction of HM/HS/TSM program elements.....	7-16

EP 1110-3-2
31 Dec 90

LIST OF FIGURES (continued)

	<u>Page</u>
Figure 7-3.	Configuration management process..... 7-17
7-4.	Example of maintenance procedures..... 7-18
8-1.	Near-surface and exoatmospheric blasts..... 8-13
8-2.	Time waveform for the free-field HEMP electric field..... 8-14
8-3.	HEMP ground coverage for bursts of various heights above the United States..... 8-15
8-4.	Reasonable worst-case TEMPEST shielding attenuation requirement..... 8-16
8-5.	Fifty-decibel (nominal) TEMPEST pipe or air duct penetration design..... 8-17
11-1.	Required electromagnetic attenuation..... 11-32
11-2.	Checklist for HEMP drawings..... 11-33
12-1.	Efficient TEMPEST facility floor plan..... 12-12
12-2.	Typical clamped modular shield room joints..... 12-13
12-3.	Typical penetration panel installation in a modular shielded enclosure..... 12-14
12-4.	Steel plate floor shield design..... 12-15
12-5.	Floor plate shield construction technique..... 12-16
12-6.	Foil wall shield construction technique..... 12-17
12-7.	Foil/foil seam..... 12-18
12-8.	Sheet metal/foil seam..... 12-19
12-9.	Foil shield pipe penetration design..... 12-20

LIST OF TABLES

Table 2-1.	Important features of EMP environments..... 2-21
2-2.	EMP waveform summary..... 2-22
2-3.	Response thresholds..... 2-23
2-4.	Typical EMP transients and equipment thresholds--EMP threat level..... 2-24
4-1.	HEMP/TEMPEST-related standards and specifications..... 4-8
4-2.	Peak magnetic field values for close lightning strokes..... 4-11
5-1.	Coefficients for magnetic field reflection loss..... 5-69
5-2.	Absorption loss of metals at 150 kilohertz..... 5-70
5-3.	Absorption loss of solid copper, aluminum, and iron shields at 60 hertz to 10,000 megahertz..... 5-71
5-4.	Reflection loss..... 5-72

LIST OF TABLES (continued)

	<u>Page</u>
Table 5-5. Shield effectiveness in magnetic field (wave impedance much smaller than 377 ohms) of solid copper, aluminum, and iron shields for signal source 12 inches from the shield at 150 kilohertz to 100 megahertz.....	5-73
5-6. Shielding effectiveness in plane wave field (wave impedance equal to 377 ohms) of solid copper and iron shields for signal sources greater than 2 inches from the shield at 150 kilohertz to 100 megahertz.....	5-74
5-7. Shielding effectiveness in electric field (wave impedance much greater than 377 ohms) of solid copper, aluminum, and iron shields for signal source 12 inches from the shield at 0.15 megahertz to 100 megahertz.....	5-75
5-8. Re-reflection (B) factors in electric, magnetic, and plane wave fields of solid copper and iron shields.....	5-76
5-9. Shielding effectiveness in electric, magnetic, and plane wave fields of copper shield (7 mils thick) for signal source 165 feet from the shield at 30 hertz to 10 gigahertz.....	5-78
5-10. Shielding effectiveness in electric, magnetic, and plane wave fields of steel shield (1 mil thick) for signal source 165 feet from the shield at 30 hertz to 10 gigahertz.....	5-79
5-11. Shielding effectiveness in electric, magnetic, and plane wave fields of steel shield (50 mils thick) for signal source 165 feet from the shield at 30 hertz to 10 gigahertz.....	5-80
5-12. Sample calculations of shielding effectiveness for solid metal shield.....	5-81
5-13. Peak voltage induced on 10-meter radius loop inside 10-meter radius spherical shield by the high-altitude EMP (by diffusion through the walls only).....	5-83
5-14. Effectiveness of nonsolid shielding materials against low-impedance and plane waves.....	5-84
5-15. Effectiveness of nonsolid shielding materials against high-impedance waves.....	5-85
5-16. Comparison of measured and calculated values of shielding effectiveness for No. 22, 15-mil copper screens.....	5-86
5-17. (Not used.)	

EP 1110-3-2
31 Dec 90

LIST OF TABLES (continued)

	<u>Page</u>
Table 5-18. Application factors for welded wire fabric.....	5-88
5-19. Typical values of conductivity for soils and rock.....	5-89
5-20. Skin depth (d) and absorption loss (A) for nonmetal materials.....	5-90
5-21. Electromotive series.....	5-91
5-22. Characteristics of conductive gasketing materials.....	5-92
5-23. (Not used.)	
5-24. Comparison of protection devices.....	5-94
5-25. Galvanic series for selected metals.....	5-95
5-26. Relative advantages and disadvantages of the principal types of earth electrodes.....	5-96
6-1. Test applicability.....	6-37
6-2. Summary of existing bounded-wave simulators.....	6-38
6-3. Summary of radiating wave simulators.....	6-39
6-4. Scaling relationships.....	6-40
6-5. Summary of quality assurance test methods.....	6-41
6-6. Comparison of shielding effectiveness test methods.....	6-42
7-1. Qualitative tradeoff study results.....	7-14
8-1. Comparison of HEMP with lightning-induced stresses on long overhead power lines.....	8-12
11-1. Power line surge arrester criteria.....	11-26
11-2. Power line filter criteria.....	11-27
11-3. Signal and control line protection: coaxial penetrations.....	11-28
11-4. Twisted shielded pair criteria.....	11-29
11-5. Terminal protection device.....	11-30
11-6. Shielding effectiveness test points.....	11-31

CHAPTER 1
INTRODUCTION

1-1. Scope.

a. Focus. The focus in this pamphlet is on electromagnetic pulse (EMP) produced by nuclear explosions at high altitudes (high-altitude EMP, or HEMP). Herein, the terms EMP and HEMP are used synonymously. In many cases facilities are not targeted for other nuclear effects and a HEMP event is the worst-case scenario for ground-based facilities. Therefore, many protective measures described herein will also protect against some other electromagnetic environments.

b. Subjects not covered. Specific protection methods for other types of EMP, such as source-region EMP and surface-burst EMP are not covered. In addition, this pamphlet does not cover protection against other effects of nuclear explosions (for example, blast overpressure & thermal/nuclear radiation).

c. TEMPEST problem. The TEMPEST problem is nearly the inverse of the HEMP event. TEMPEST is the unclassified name for the studies and investigation of compromising emanations. Equipment within the facility can be the source of electromagnetic waves and stray currents/voltages with characteristics which are related to the information content of signals being processed. If these unintentional emissions are intercepted and studied, the analyst can reconstruct the original data and could gain access to national security information. A proper TEMPEST design, however, will preclude the presence of analyzable signals in uncontrolled areas.

d. Common treatment. Thus, HEMP and TEMPEST protective measures must each control electromagnetic energy, the former protecting system equipment from externally generated signals and the latter containing emissions from internal sources. The functional similarities imply that a common treatment can be employed for the two purposes.

1-2. Application. Information in this pamphlet is applicable to engineers responsible for the design, construction, and maintenance of mission-critical facilities, such as those supporting the command, control, communications and intelligence network. The information is relevant to new construction as well as to additions, upgrades, and retrofits to existing facilities.

1-3. References. This pamphlet is intended to stand alone and, as such, no additional references should be required to understand the material herein. However, only a small sample of the material published on HEMP and TEMPEST can be highlighted here. Because different facilities will have differing requirements for protection, supplementary sources are listed at the end of

EP 1110-3-2
31 Dec 90

most chapters to assist the engineer in designing protection on a case-by-case basis.

1-4. Background.

a. Reliance on electronic technology. Military facilities are becoming increasingly reliant on automated systems that take advantage of modern electrical and electronic technology. Facilities are equipped with state-of-the-art computerized systems for expeditious, reliable, and cost-effective operations. However, the electromagnetic (EM) properties of many electronic components can make entire systems susceptible to upset or permanent damage due to the environmental effects of EMP. Systems are also susceptible to the compromise of security information by the unintentional intelligence-bearing emanations of electromagnetic signals. Thus, with the benefits of automation has come an increased vulnerability.

b. Early planning. Techniques to protect a facility are usually selected during the early design phase. If it is anticipated that a facility may someday acquire equipment that must be protected, early planning can avoid costly retrofitting later. The decision to harden will be based on the interaction of mission criticality, electromagnetic environment, security requirements, and costs.

c. Far-reaching effects. HEMP is dangerous because this event has far-reaching effects at distances where other nuclear environments are either nonexistent or inconsequential and because of its high level of broad spectral energy. However, the spectrum included under HEMP does not cover all EM environments. For example, the characteristic pulse risetime and possible conducted current waveforms for lightning differ from those for HEMP; thus, hardening against HEMP does not necessarily protect against lightning.

d. Evolving technology. It is important to note that this field is relatively new and that technical expertise is still evolving. Therefore, it is the designer's responsibility to stay current with new developments to assure the most cost-effective reliable configuration for vital military fixed facilities.

1-5. Pamphlet organization. At the beginning of each subsequent chapter, there is an outline. The purpose of the outline is to provide more detail on the chapter's content than is ordinarily appropriate in a table of contents.

CHAPTER 2

EMP ENVIRONMENT

2-1. Outline. This chapter is organized as follows:

2-1. Outline

2-2. HEMP: detailed discussion

a. HEMP generation

- (1) Gamma radiation
- (2) Compton scattering
- (3) Deposition region
- (4) Radiating magnetic field

b. HEMP ground coverage

c. Field strength vs ground location

d. Electric field

e. Transients

- (1) Transient definition
- (2) HEMP event time phases
- (3) Qualitative characteristics

f. Magnetohydrodynamic EMP (MHD-EMP)

- (1) Early-phase generation
- (2) Late-phase generation
- (3) Electronic surge arresters

2-3. Other EMP environments

a. Surface burst EMP (SBEMP)

- (1) Source region
- (2) Electric and magnetic field relationship
- (3) Radiated region

b. Air-burst EMP

- (1) Source region
- (2) Radiated region

c. System-generated EMP (SGEMP)

- (1) Coupling modes
- (2) Transient radiation effects on electronics

d. Summary

2-4. Environment-to-facility coupling

a. Modes of HEMP entry

- (1) Diffusion through the shield
- (2) Leakage through apertures
- (3) Intentional and inadvertent antennas

b. Conductive penetrations

- (1) Basic coupling mechanisms
- (2) HEMP coupling analysis
- (3) Intrasite cables

2-5. Equipment susceptibility

a. Equipment response

- (1) Upset

EP 1110-3-2
31 Dec 90

(2) Damage

b. Equipment sensitivity

c. Typical damage and upset levels

2-6. Cited references

2-7. Uncited references

2-2. HEMP: detailed discussion.

a. HEMP generation. HEMP is caused by a nuclear burst at high altitudes. Prompt gamma rays following the nuclear detonation are the principal source of HEMP. This gamma radiation causes bursts of electron flow from the Compton effect, a photoelectric effect, and a "pair production" effect. Of these three effects, however, the primary source of HEMP is the Compton effect. Due to their low level of significance, the photoelectric and "pair production" effects are not discussed.

(1) Gamma radiation. At high altitudes (above 30 kilometers), the atmosphere is thin and thus allows gamma radiation from the nuclear burst to travel out radially for long distances (ref 2-1). Below the center of the burst, however, the atmospheric density increases as the Earth's surface is approached. The prompt gamma rays propagate toward the Earth in a thin spherical shell, moving at the speed of light away from the burst..

(2) Compton scattering. When the downward directed rays encounter the upper regions of the atmosphere, they begin to interact with the atoms (or molecules) of the atmosphere at a rate which is a function of atmospheric density and burst conditions. The dominant interaction is Compton scattering, in which the energy of a gamma ray is partially transferred to an electron of an air atom (or molecule). The electron then begins traveling in approximately the same direction as the gamma ray. The other product of collision is a gamma ray of reduced energy. Figure 2-1 illustrates this process (ref 2-1). The spherical shell of gamma rays is converted during Compton scattering into a spherical shell of accelerated electrons.

(3) Deposition region. The region in which Compton scattering occurs is called the deposition region. The thickness and surface range of the deposition region is a function of height-of-burst (HOB) and weapon size and type. A representative thickness is from 20 kilometers to 40 kilometers, but a deposition region may be as thick as 70 kilometers (10-kilometer to 80-kilometer altitude) for a 300-kilometer HOB and a 10-megaton weapon.

(4) Radiating magnetic field. In the spherical shell of Compton electrons, the electrons are charged particles that rotate spirally around the Earth's geomagnetic field lines (ref 2-2). The electrons thus have a velocity component transverse to the direction of the gamma radiation. These transverse currents give rise to a radiating magnetic field. This field propagates through the atmosphere to the Earth's surface as if it were contained in the same spherical shell as that formed by the original gamma ray shell.

EP 1110-3-2
31 Dec 90

b. HEMP ground coverage. Significant HEMP levels can occur at the Earth's surface out to the tangent radius (and beyond, for frequencies below 100 kilohertz). The tangent radius is where the line of sight from the burst is tangent with the Earth's surface. If one assumes a spherical Earth of radius R_e , the tangent radius R_t is given by--

$$R_t = R_e \cos^{-1} \left(\frac{R_e}{R_e + \text{HOB}} \right) \quad (\text{eq 2-1})$$

where HOB is the height of burst. For an approximate Earth radius of 6371 kilometers, an HOB of 100 kilometers corresponds to an R_t of 1121 kilometers, an HOB of 300 kilometers corresponds to an R_t of 1920 kilometers, and an HOB of 500 kilometers corresponds to an R_t of 2450 kilometers. Thus, the HEMP generated by a nuclear explosion at an altitude of 500 kilometers would illuminate the whole continental United States. If high-yield weapons are used, the field strength will not vary much with HOB, so this large geographic area can be covered with little reduction in peak field strength.

c. Field strengths versus ground location. HEMP fields can be significant out to the tangent radius, but the exact field strength as a function of ground position depends on many factors. Burst-observer geometry is important because HEMP is produced by electron motion transverse to the Earth's magnetic field. Thus, electron moving along the field do not radiate. For a burst at high geomagnetic latitudes, as would be the case for Europe or North America, the pattern shown in figure 2-3 results. There will be a region of near-zero field strength north of the sub-burst point, where the magnetic field lines from the burst site intersect the Earth. There will also be a broad arc of maximum field strength that corresponds to electron trajectories perpendicular to the geomagnetic field. The field amplitude is an appreciable fraction of the peak amplitude (about 0.5 for most high-yield weapons) out to the tangent radius. The EMP field strength will also vary as a function of HOB, weapon yield (especially gamma yield), and geomagnetic field, which depends on geomagnetic latitude. Near the equator, the Earth's magnetic field strength is weaker and the orientation is very different, so peak HEMP fields would be smaller and the field strength pattern much different than that shown.

d. Electric field. A commonly used unclassified time waveform of a HEMP electric field $E(t)$ in free space can be approximated by the analytical expression--

$$E(t) = \frac{kE_{pk} e^{-a(t-t_s)}}{1+e^{(a+b)(t-t_s)}} \quad (\text{kV/m}) \quad (\text{eq 2-2})$$

EP 1110-3-2
31 Dec 90

where $E_{pk} = 50$ kV/m (peak electric field in kilovolts per meter; $k = 1.2$ (a normalization constant); $a = 5 \times 10^8$ per second (exponential decay rate); $t_s = 10^{-8}$ seconds (a time shift parameter); and t is the time of interest (in seconds). This waveform is often called a "double exponential." Figure 2-4 is a graphic representation of the HEMP waveform; the frequency content of the HEMP pulse also is depicted in figure 2-4. This waveform rises from 0.1 to 0.9 times its peak amplitude in about 5 nanoseconds (t_r), and decays to one-half its peak amplitude in about 200 nanoseconds ($t_{1/2}$) (fig 2-4). The upper left curve shows this waveform plotted on a linear time scale. The upper right curve shows a logarithmic time scale that distorts the pulse shape but gives the risetime more clearly. The Fourier transform of this transient electric field is given by--

$$E(u) = \frac{2.47 \times 10^{13}}{(ju + 4 \times 10^6)(Ju + 4.76 \times 10^8)} \text{ volt second per meter} \quad (\text{eq 2-3})$$

where j is the unit imaginary number and, u is the radian frequency. As the lower curve shows (fig 2-4), the electric field strength stays fairly constant in the 10-kilohertz to 1-megahertz frequency range, declines by a factor of 100 in the 1- to 100-megahertz range, and continues to decrease at a more rapid rate for frequencies greater than 100 megahertz. HEMP energy generally ranges from frequencies of 0.1 to 10 megahertz, with all but 1 percent falling below 100 megahertz.

(1) Transients. The transient expected from HEMP has recently been redefined analytically. Details of this new definition are classified and thus cannot be presented here (DOD-STD-2169(C), ref 2-3).

(2) Transient definition. In DOD-STD-2169, EMP experts have divided the time representation of the HEMP event into three periods: early time, intermediate time, and late time.

(a) The early-time portion arrives at the Earth's surface quickly and lasts about 1 microsecond. This is the portion caused by the first gamma ray pulse. It is a fast spike and has its energy concentrated in the one to several hundred megahertz frequency band.

(b) Intermediate-time HEMP occurs between 1 microsecond and 0.1 second and has a frequency spectral content between 1 hertz and 100 kilohertz. It is primarily a high-impedance field.

(c) Late-time HEMP is primarily the magnetohydrodynamic (MHD) EMP occurring from 0.1 to 1000 or more seconds. MHD-EMP is discussed in paragraph f below.

EP 1110-3-2
31 Dec 90

(3) Qualitative characteristics. Figures 2-5 and 2-6 show unclassified qualitative HEMP characteristics.

f. Magnetohydrodynamic EMP (MHD-EMP). MHD-EMP is the late time ($t > 0.1$ second) component of EMP caused by a high-altitude nuclear burst. Two distinct physical mechanisms are thought to produce different parts of the MHD-EMP signal: an "early phase" from 0.1 to 10 seconds after the detonation, and a "late phase" lasting from 0.1 to 1000 seconds. MHD-EMP fields have low amplitudes, large spatial extent, and very low frequency. Such fields can threaten very long landlines, including telephone cables and power lines, and submarine cables.

(1) MHD-EMP early-phase generation. A nuclear burst at high altitudes gives rise to a rapidly expanding fireball of bomb debris and hot ionized gas. This plasma tends to be diamagnetic in that it acts to exclude the Earth's magnetic field from the inside of the fireball. Thus, as the fireball expands and rises in early stages, it will deform the geomagnetic field lines and thereby set up the early phases of the MHD-EMP, which can propagate worldwide. The region on the ground immediately below the burst is shielded from early-time MHD-EMP by a layer of ionized gas (the X-ray patch) produced by X-rays from the nuclear burst.

(2) MHD-EMP late-phase generation. Residual ionization and the bomb-heated air under the rising fireball are mainly responsible for the late phase of the MHD-EMP. As the bomb-heated air rises, residual ionization moves across geomagnetic field lines and large current loops form in the ionosphere. The ionospheric current loops then induce earth potentials. The late phase of the MHD-EMP is seen in large sections of the Earth's surface, including regions at the magnetic conjugate points. Though amplitudes are smaller than for HEMP, the low-frequency fields can introduce damaging potential differences on long cable systems.

(3) Electronic surge arresters. The longer duration and greater energy content coupled into electrical lines in the DOD-STD-2169 environment is an important factor in the design and selection of electronic surge arresters.

2-3. Other EMP environments. Of several different kinds of EMP environments, HEMP is the one specified most often for system survivability. The discussion of HEMP applies to all systems that must survive a nuclear event, even though they are not targeted or even located close to a target. One reason is that the peak field amplitudes are large enough to damage or upset most unprotected electronic systems that use solid-state technology. Further, the frequency band is broad and thus all types of electronic/electrical systems are potentially susceptible. Third, as discussed previously, the HEMP area coverage is large. The fact that HEMP occurs when other nuclear environments are absent implies that systems with no defense against other nuclear effects may need protection against HEMP. Although HEMP is a vital concern for mission-critical systems and is the environment addressed in this manual,

EP 1110-3-2
31 Dec 90

other environments are briefly discussed for the sake of completeness. Table 2-1 lists some of the other EMP environments and compares their properties.

a. Surface burst EMP (SBEMP). SBEMP is produced by a nuclear burst close (less than 0.2 kilometer) to the Earth's surface (fig 2-7). The EMP is generated in the source region, which extends out to a radius of 3 to 5 kilometers from the burst. EMP environments inside the source region can affect systems such as ICBMs or command centers that have been hardened to withstand nuclear blasts, thermal energy, and radiation inside the source region. A surface burst also has fields radiating outside the source region, with those field amplitudes significant (greater than 5 kilovolts per meter) out to ranges of 10 kilometers and more. In this range, the radiated EMP is a principal threat to systems that respond to very low frequencies or have very large energy collectors such as long lines. Conducted EMP for these systems is such that special attention must be given to surge protection to ensure that the high currents can be dissipated.

(1) Source region. The generation of EMP by a surface burst starts when the gamma rays travel out radially from the burst. These rays scatter Compton electrons radially, leaving behind relatively immobile positive ions (fig 2-8). This charge separation produces radial electric fields (E_r) with amplitudes over 100 kilovolts per meter (amplitudes may approach 1 megavolt per meter) and risetimes as short as a few nanoseconds. Since the ground conducts better than the air at early times, the strong radial electric field causes a ground current to flow in a direction opposite to the radial Compton current in the air. The resulting current loops produce azimuthal magnetic fields. Magnetic fields are strongest at the Earth's surface and diffuse both upward and downward from the interface. The discontinuity due to the air-Earth interface also generates strong vertical electric fields in the source region. Source region fields depend strongly on factors such as weapon yields (gammas and neutrons), HOB, and distance from the burst. The interaction with a system is very complex: besides the EM fields, the system may be exposed to nuclear radiation, in addition to being located in a region of time-varying currents and conductivity. In specifying a source region environment for a system, then, the concept of balanced survivability is useful, as it is with all EMP environments. If a facility is designed to withstand ionizing radiation and other nuclear effects at a specified range from a given burst, it should also be designed to withstand the EMP effects generated at that range.

(2) Electric and magnetic field relationship. The time-varying currents and conductivity of the surface-burst source region imply a complex relationship between electric and magnetic fields, which does not show the simple magnitude and direction relationships of a plane wave. Determination of these relationships is beyond the scope of this manual.

(3) Radiated region. Outside the source region, the most important feature of the charge distribution produced by a surface burst is the asymmetry due to the air-earth interface (fig 2-8). In an infinite uniform

EP 1110-3-2
31 Dec 90

atmosphere, Compton electrons would travel out radially in all directions. However, for SBEMP, the earth interferes with down-flowing electrons, which results in a net vertical flow of Compton current. This produces a time-varying vertical dipole that radiates outside the source region. The main components of the radiated field are the vertical electric field and the azimuthal magnetic field. The field amplitude has a $1/R$ dependence with range, as is typical of electric dipole radiation. The field rises quickly to its first peak (electric field vector vertically upward), with a second peak of opposite sign following some tens of microseconds later. More of the energy occurs at lower frequencies than for HEMP. Figure 2-9 shows the calculated electric field amplitude as a function of range for a large surface burst. As the figure shows, radiated surface burst field amplitudes most often are smaller than HEMP fields outside the source region. However, field amplitudes can still be significant at ranges of 10 kilometers or more. The right portion of the curve shows the inverse relationship between amplitude and range beyond 5 kilometers. This is typical of electric dipole radiation in the far-field region. There is no standard waveform as there is for HEMP. Thus, the very concept of a standard waveform is less likely to be useful for SBEMP because of the variation in amplitude and waveform with range and weapon yield (output). Radiated SBEMP typically gives off most of its energy at lower frequencies (below 100 kilohertz). The increase in low frequency content and the vertical electric field orientation mean that the system impact of radiated SBEMP may be more important than that of HEMP for some systems, even though HEMP field magnitudes are generally larger.

b. Air-burst EMP.

(1) Source region. Air-burst EMP results from a nuclear explosion at intermediate altitudes--2 to 20 kilometers. The EMP produced by a burst at heights between 0.2 and 2 kilometers will share characteristics of air and surface bursts, and a burst between 20 and 40 kilometers will cause EMP sharing characteristics of air-burst and high-altitude EMP. The source region resembles the surface-burst source region in that weapon gammas scatter Compton electrons radially outward (fig 2-10). Positive ions are left behind, producing charge separation and radial electric fields. For air-burst EMP, there is no return path through the ground. Due to ionization, however, increased air conductivity enables a conduction current to flow opposite the Compton current in the air. Still, no significant current loops are formed, and the large azimuthal magnetic fields typical of a surface burst do not result.

(2) Radiated region. Outside the source region, the radial charge separation resulting from the Compton current will produce some radiated fields because a slight asymmetry exists. At intermediate altitudes, the atmospheric density gradient permits Compton electrons to move farther up than down. This asymmetry results in electric dipole radiation (fig 2-11). The water vapor density will also vary with height, though this variation depends on the weather. A typical decrease in water vapor density with altitude will reinforce the asymmetry produced by the atmospheric density gradient. Even

EP 1110-3-2
31 Dec 70

with these two effects combined, the asymmetry is much weaker than for a surface burst. The typical field strengths produced are on the order of 300 volts per meter at 5 kilometers from the burst. Pulse waveforms vary significantly with burst altitude and assumed water vapor gradient, with typical risetimes in the 1- to 5-microsecond range. The recoil Compton electrons can also produce a radiated signal by the same geomagnetic turning mechanism that gives rise to HEMP. This is called magnetic dipole radiation. At low altitudes, electron paths are short so that peak amplitudes are limited to hundreds of volts per meter, mainly to the east and west of the burst. The peak amplitude increases with burst height until it reaches tens of kilovolts per meter as the burst approaches the high-altitude region. Rise and decay times are similar to those for HEMP--on the order of tens of nanoseconds.

c. System generated EMP (SGEMP). SGEMP results from the direct interaction of nuclear weapon gammas and X-rays with the system. Because weapon gammas and X-rays are attenuated by the atmosphere at low altitudes, SGEMP has special importance for systems outside the atmosphere, such as satellites in space and missiles in flight. These can receive significant gamma and X-ray exposures at considerable distances from a nuclear burst. SGEMP involves complex modes of field and current generation that strongly depend on the system's physical and electrical configuration. As a result, there is no standard threat. The field amplitudes generated can be as large as 100 kilovolts per meter, making SGEMP a significant threat to exposed systems.

(1) Coupling modes. The initial physical process is the generation of energetic free electrons by Compton and photoelectric interactions of weapon X-rays and gammas with the system materials. Emitted electrons produce space-charge fields that turn back later electrons or, at higher gas pressures, cause appreciable ionization. Emission of the electrons from internal walls results in current generation and, hence, EM fields inside cavities. This effect is termed internal EMP (IEMP). Coupling occurs both by electric and magnetic field coupling directly onto signal cables and by induced current flow on cable shields and ground systems. The asymmetric displacement of electrons from a cable shield and from internal conductors and dielectrics inside a single cable or cable bundle produces a distributed current generator over the whole exposed region of the cable. Electron emission from the outer skin of the subject system generates whole body interaction effects that produce charge displacement and direct field coupling. These effects also can influence internal EMP if there are penetrations or openings to the inside.

(2) Transient radiation effects on electronics. The direct impingement of radiation (e.g., X-rays, gamma rays, neutrons) can also change the performance of semiconductor electronics through atomic interactions. Operating thresholds, junction voltages, and the crystalline structure of solid-state materials can be affected, thus changing the way devices and circuits using such materials operate. TREE normally is important only when modern electronics might be exposed to the nuclear detonation source region with a high in-flow of nuclear radiation.

EP 1110-3-2
31 Dec 90

d. Summary. Table 2-2 outlines the EMP waveforms important for critical systems. HEMP is the most difficult threat to harden against because of its large spatial extent, high amplitude, and broad frequency coverage. It is also the simplest threat to describe using the waveform definition in equation 2-2 and the plane wave approximation. The source region for an air or surface burst combines intense fields with significant time-varying conductivities and environments. Source-region EMP is important for systems that can withstand other nuclear environments present in the source region. EMP radiated from a surface burst usually has lower amplitude than HEMP and can affect systems more due to the vertical field orientation and lower frequency. Air-burst radiated fields have lower amplitudes and are less likely to be important (a system hardened to survive HEMP will survive radiated air-burst EMP). SGEMP is characterized by very high amplitudes, very fast risetimes, and importance to systems outside the atmosphere. MHD-EMP has low amplitude but can damage the interface circuits of long landlines or submarine cables.

2-4. Environment-to-facility coupling. To analyze how HEMP will affect facilities and electronic equipment, the exterior free field threats must be related to system, subsystem, and circuit responses. The functional relationship between external causes and internal effects is often called a "transfer function." The analysis involves learning how the system collects energy from the incident HEMP field. The result is usually a matrix of internal fields and transient voltages and currents that may flow in circuits and subsystems. This is called a "determination of the coupling interactions between the external threat and the system." Generally, HEMP enters shielded enclosures by three different modes: diffusion through the shield; leakage through apertures such as seams, joints, and windows; and coupling from intentional or inadvertent antennas. These different modes are shown in figure 2-12 and are discussed next.

a. Modes of HEMP entry.

(1) Diffusion through the shield. HEMP fields diffuse through imperfectly conducting walls of shielded enclosures. The diffusion is greatest for magnetic fields and is a low-pass filtering event, as shown by the magnetic shielding effectiveness curve for an ideal enclosure (fig 2-13). Thus, the field that reaches the inner region of a shielded enclosure is basically a low-frequency magnetic field. This effect is greatest in an enclosure with solid metal walls. It is also seen somewhat in enclosures with metal rebar or wire mesh reinforcement. The shielding effectiveness (SE) for an enclosure with rebar is also shown in figure 2-13. The reduced SE at high frequencies for rebar and wire mesh structures allows a significant fraction of the incident HEMP environment to penetrate to electronics inside the enclosure.

(2) Leakage through apertures. Openings and other shielding compromises include doors, windows, holes for adjustments and display units, seams, improperly terminated cable shields, and poorly grounded cables.

EP 1110-3-2

31 Dec 90

Unless properly treated, each opening is a leak through which the HEMP field can couple directly into the shielded enclosure. Leakage through an aperture depends on its size, the type of structure housing it, and its location. The aperture responds to both total magnetic and electric fields at the site of the leak. The effect of apertures on the magnetic SE of an ideal enclosure is shown in figure 2-14.

(3) Intentional and inadvertent antennas. Intentional antennas are designed to collect EM energy over specified frequency bands. However, there will also be an out-of-band response to HEMP. Because the incident HEMP field has a broad frequency spectrum and high field strength, the antenna response must be considered both in and out of band. Analytical models are available for determining the different antennas' responses to HEMP. These models, along with the incident field, yield the HEMP energy that appears at the connecting cable. This energy later reaches the electronic systems inside the enclosure at the other end of the connecting cable. Inadvertent antennas are electrically conducting, penetrating external structures, cables, and pipes that collect HEMP energy and allow its entry into the enclosure. As a rule, the larger the inadvertent antenna, the more efficient energy collector it is in producing large, transient levels in the enclosure. Figure 2-15 shows some inadvertent antennas for a ground-based structure. The coupling for inadvertent antennas can be analyzed using transmission line and simple antenna models. These analyses, however, are complex and beyond the scope of this manual. The reader is directed to references 2-2 and 2-6 for guidance on these analyses.

b. Conductive penetrations. Many factors affect the coupling of EM energy to penetrating conductors. The EMP waveform characteristics, such as magnitude, rate of rise, duration, and frequency, are each important. Further, the observer's position with respect to the burst is a factor. Because the interaction between fields and conductors is a vector process, the direction of arrival and polarization is also important. Conductor characteristics also affect HEMP coupling. These include conductor geometry (length, path, terminations, distance above or below the earth's surface), physical and electrical properties that determine series impedance per unit length (including diameter, resistivity, and configuration), and the presence and effectiveness of shielding. For overhead or buried conductors, the electrical properties of soil affect coupling. Though dielectric permittivity and magnetic permeability may be significant, soil conductivity is usually the greatest determining factor for coupling. This is because both HEMP attenuation in the ground and reflection from the ground increase with greater soil conductivity. The soil skin effect also varies. An EM wave in a conductive medium attenuates to 0.369 of its initial amplitude in a distance $d = (2/pwc)^{1/2}$, where d is the skin depth, p is the magnetic permeability of the medium, w is the angular frequency, and c is the conductivity. Because the skin depth is greater at lower frequencies, lower frequency field components attenuate less and the pulse risetime increases. Many elements of a facility can act as efficient collectors and provide propagation paths for EMP energy. As shown in figure 2-16, EMP can couple to structures such as

EP 1110-3-2
31 Dec 90

power and telephone lines, antenna towers, buried conduits, and the facility grounding system. Actual antennas, nonelectrical penetrators such as waterpipes, and any other conducive penetration can couple EMP energy into a structure. In addition, if the structure is not shielded or is not shielded well enough, EMP can couple to the cables between equipment inside. Paragraphs (1) through (3) below briefly describe coupling mechanisms, including theory, and give rough values for the currents and voltages that can arise from a typical EMP event.

(1) Basic coupling mechanisms. Figure 2-17 shows two basic modes by which currents and voltages are induced in conductors. One mechanism shown is that for inducing voltage in conductors by electric field. The electric field exerts forces on the "mobile" electrons in the conductor, which results in a current. The voltage associated with the force is the integral of the tangential component of E along the length of the wire. This assumes the electric field is constant over the length of the wire and is parallel to it. The other mechanism by which currents are induced on conductors is through changes in the magnetic field, also shown in figure 2-17. Faraday's Law is the mathematical expression that describes this phenomenon. This law relates the time rate of change of the magnetic field to the production of an associated electric field. This electric field "curls" around the changing magnetic field and causes a voltage if a loop is present. The voltage for the loop of area A in the figure is $V = A(dB/dt)$, where B is normal to the loop and has the same magnitude over the whole loop. This can give a good approximation with HEMP when the magnetic field can be considered uniform over the area of the loop. The fast rise rate of the magnetic field can produce large currents and voltages. A sample calculation is helpful. Assume the following--

$$A = \text{loop area} = 0.1 \text{ meter squared (m}^2\text{)}$$

$$E(t) = Ce^{-t/a} \text{ where } C = 50,000 \text{ volts/meter}$$

$$a = 0.5 \times 10^{-6} \text{ (time constant)}$$

(Note: a simple exponential is used for this example.)

$$H = E/377 \text{ (a plane wave)}$$

$$= e^{-t/a}(C/377)$$

$$u = u_0 \text{ (loop antenna in free space)}$$

$$u_0 = 4(\pi) \times 10^{-7} \text{ Webers/amp-meter}$$

Then:

$$H = 50,000/377 e^{-t/0.5 \times 10^{-6}} \text{ amps/meter}$$

$$= 132.6 e^{-t/0.5 \times 10^{-6}} \text{ amps/meter}$$

EP 1110-3-2
31 Dec 90

$$\begin{aligned}
 B &= u_0 H = 4(\pi) \times 10^{-7} \times 132.6 e^{-t/0.5 \times 10^{-6}} \text{ Webers/meter}^2 \\
 \text{Loop voltage } V_L &= A \text{ (dB/dt)} \\
 &= 0.1 \text{ meters}^2 \left(\frac{d(4(\pi) \times 10^{-7} \times 132.6 e^{-t/0.5 \times 10^{-6}}) \text{ Webers/meter}^2}{dt} \right) \\
 &= 0.1 (2 \times 10^6 \times 4(\pi) \times 10^{-7} \times 132.6 e^{-t/0.5 \times 10^{-6}}) \text{ Webers/second} \\
 &= -33.3 e^{-t/0.5 \times 10^{-6}} \text{ volts.}
 \end{aligned}$$

(2) HEMP coupling analysis. This section describes some of the more important coupling interactions in the design and analysis of shielded facilities.

(a) Equivalent circuit for a small electric dipole. A small electric dipole is one with a short length compared with the dominant wavelengths incident on it. A HEMP contains 99 percent of its energy in wavelengths longer than 3 meters. The analysis done here using a small dipole model is significantly more accurate for dipoles less than 3 meters. The model is fairly simple and serves to show how EMP coupling calculations are done. Figure 2-18 shows a dipole and its equivalent circuit. The voltage is induced by the EMP. The capacitance is caused by the two halves of the dipole acting like two plates of a capacitor. For large resistance R_L ($R_L \gg 1/\omega C_A$), the capacitance has almost no effect and the voltage across the equipment terminals is in phase with the incident electric field. For small R_L ($R_L \ll \omega C_A$), the capacitance takes effect. Then--

$$Q = CV_{oc} = C_A \{-hE \sin(\theta)\} \quad (\text{eq 2-4})$$

$$V_L = IR_L = \frac{dQ \cdot R_L}{dt} = R_L \{-hC_A \cdot \frac{dE}{dt} \cdot \sin(\theta)\} \quad (\text{eq 2-5})$$

(b) Equivalent circuit for a small loop (magnetic dipole). For HEMP, a small loop is one with a radius less than 3 meters. Loop antennas can be a major source of EMP-induced currents and voltages because of the EMP's quickly changing magnetic field. Figure 2-19 shows a loop antenna and its equivalent circuit. The voltage is induced by the EMP. The resistance, R_L , is the equipment or load resistance. The inductance, L_A , is due to the loop. For large R_L ($R_L \gg \omega L_A$), the inductance has almost no effect. Thus, the voltage is proportional to the area of the loop and the rate of change of the transverse magnetic field. For small R_L ($R_L \ll \omega L_A$), the inductance takes

effect and the current in the loop is proportional to the magnetic field. The current will flow in a way that makes the magnetic flux through the loop due to the current cancel the magnetic flux through the loop due to the field.

(c) Typical coupling model. In actual coupling calculations, it is often hard to depict a structure using the small dipole circuits just described. For example, the microwave tower in figure 2-20 is not small compared to a 3-meter wavelength, and it would be hard to represent it by superimposing loops of different sizes, shapes, and orientations. Instead, such a structure can be electrically approximated by a monopole of the same height and of some effective radius, a_e . An upper bound on the effective radius is given by the tower dimensions at the base. The effect of ground is approximated by assuming an infinitely conducting ground plane. For a worst-case vertical orientation, the equivalent fat monopole over an infinitely conducting ground plane is equal to a dipole of the same radius and twice the height in free space. Models such as this can be used to find bounds or orders of magnitude for coupling to large or complex structures. Model validity or accuracy depends on the amount and kind of approximation used and on how well results agree when compared empirically with experimental or complex analytical data.

(d) Shielded cable coupling. To analyze the transients induced on cables by EMP, two calculations usually are needed to find the coupling onto the cable sheath and the voltage and resultant currents induced on the internal wires. The calculation of coupling onto the cable sheath depends on cable construction and location, and will be discussed for some typical cases later. Figure 2-21 shows the calculated voltage induced on a wire inside a shielded cable. The transfer impedance can be found theoretically, especially for simple cable shields such as solid metallic conduits. For example, the transfer impedance of a thin-walled tubular shield is given by--

$$Z_T = \frac{1}{2(\pi)rcT} \cdot \frac{(1+j)T/d}{\sinh(1+j)T/d} \quad (\text{eq 2-6})$$

where r is the radius of the shield, c is its conductivity, T is the wall thickness, j is the unit imaginary number, and d is the skin depth. Some geometries, however, such as braided coaxial cables, are too complex for theoretical treatment. Thus, it is often preferable to determine the transfer impedance by experiment. For braided coaxial cables, the transfer impedance is typically expressed as--

$$Z_T = R_0 \left(\frac{(1+j)s/d}{\sinh(1+j)s/d} \right) = j\omega M_{12} \quad (\text{eq 2-7})$$

where R_0 is the d.c. resistance per unit length, j is the unit imaginary number, s is the shield wire diameter, d is the skin depth, ω is the angular frequency, and M_{12} is the leakage inductance per unit length. For typical

EP 1110-3-2

31 Dec 90

braided coaxial cables, R_0 ranges from 1 to 25 milliohms per meter and M_{12} ranges from 0.1 to 1 nanohenry per meter. At low frequencies, $s/d \ll 1$ and $\omega M_{12} \ll R_0$ and Z_T reduces to R_0 . For example, for an RG-58 coaxial cable at $f = 10^4$ hertz, $d = 0.24 \ll 1$ and $\omega M_{12} = 0.01$ milliohms per meter $\ll R_0 = 14.2$ milliohms per meter so the transfer impedance is about equal to R_0 . A 500-amp current on a cable length of 100 meters will therefore induce a voltage drop on the center conductor of 500 amps(100 meters)(14.2 milliohms per meter) = 710 volts.

(e) Transmission line coupling. Transmission line theory is the chief method used to calculate EMP coupling to aerial and buried conductors, simple cables, and other long penetrators (e.g., pipes, ducts). A transmission line picks up EMP from both the electric field and the changing magnetic field. The loop formed by the line, its terminations, and the ground behaves much like a loop antenna and picks up EMP from the transverse changing magnetic field. The links between the line and ground behave much like dipole antennas and pick up EMP from the vertical electrical field. The line also picks up EMP from the longitudinal electric field. Though this last source seems the most clearcut, it does not cause as much of the total current and voltage as the other two. The transmission line theory involves many points that were ignored in the analyses of small dipole and loop antennas. First, the conductor is long compared to the incident wavelengths. This means that currents and voltages will differ everywhere on the line. Also, there will be reflection from the ground plane. With all such factors taken into account, an analytical solution can be obtained, often with the help of a computer. This solution usually involves the short circuit current and the open circuit voltage at the line's termination. Figure 2-22 shows an approximate model of this EM coupling. The transmission line is broken into N sections. N is chosen based on the bandwidth needed in the model. One- to three-foot sections are typical. Each inductor and capacitor in the model is chosen such that $L = Z_0 T/2$ and $C = T/Z_0$, where Z_0 is the characteristic impedance and T is the transit time in each section. The voltage source in each section depends on the incident fields. This theory also applies to transmission lines with multiple cables. In this case, a source and load impedance will exist between each cable and ground and between each cable and every other cable. Current and voltages will be induced between the cables. This is caused by the changing magnetic field component transverse to the loop formed by two cables and by the electric field component pointing between them. This kind of EMP pickup is called the differential mode. EMP pickup causing currents and voltages between each cable and ground is called the common mode. These two modes are often treated separately and both create a need for protection.

(f) Aerial conductors. Long, straight, horizontal aerial conductors include pole-mounted power distribution lines and signal-carrying cables. Figure 2-23 shows how the peak coupled current and the time-to-peak depend on the line length. The peak current and time-to-peak also depend on the line's height above ground, its size and construction, the soil conductivity, and other factors. The figure shows peak currents calculated for a pulse of the form $E_0 e^{-t/\tau}$, where E_0 is the peak field amplitude of 50 kilovolts per meter

EP 1110-3-2
31 Dec 90

and x is an exponential decay constant of 250 nanoseconds. This waveform looks much like the standard double exponential discussed earlier. It is used here to make calculations easier. Grazing, end-on incident is assumed with a polarization of about 16 degrees from the horizontal. The vertical field component for this polarization angle is 15 kilovolts per meter. The horizontal field component is much larger (about 48 kilovolts per meter), but it gives rise to a smaller induced current because of transmission line behavior. This polarization is typical of that expected at latitudes in the United States where the magnetic dip angle is more vertical than horizontal. A worst-case angle of incidence is assumed. Figure 2-23 shows how peak current as a function of the line length approaches a limiting value, in this case about 10 kiloamps. The point at which the limiting value is reached is called the critical line length. The time required for the current to reach its peak value also increases with line length until a limiting value is reached. Figure 2-23 also shows the bulk current that will be induced on the aerial conductor. If the conductor is a shielded cable, the values shown will correspond to the sheath current. The currents induced on conductors inside the shield will depend on the transfer impedance.

(g) Buried conductors. Buried conductors can be significant EMP collectors because low-frequency components of EMP fields are not greatly attenuated for typical soil conductivities and burial depths. The amplitude of the induced current varies inversely with the square root of the soil conductivity, which ranges from 10^{-4} to 10^{-2} mhos per meter. Figure 2-24 shows the variation in induced cable current with burial depth. The effect of deeper burial is both to reduce the amplitude of the induced current and to increase the risetime to peak current because of increased skin depth. (See para 2-4b above.) Figure 2-24 is for a semi-infinite cable. A finite cable will show a different response, especially near the cable ends. The differences in response are related to the cable sheath material and the way the cable is grounded. The cable's induced current also depends on the amplitude, waveform, and direction of the incident pulse. It will be proportional to the amplitude of the incident pulse (E_0). It will also be proportional to the square root of the decay time constant (T) of the incident pulse for an assumed exponential waveform $E(t) = E_0 e^{-t/T}$. This constant is nearly the same as beta in the standard double exponential waveform. In the figure, the pulse is incident from directly overhead with the electric field parallel to the cable. This is a worst-case orientation. The current given in the figure corresponds to the total current induced on the cable, mainly sheath current, that can be related to the current on conductors inside the shield in terms of the transfer impedance.

(h) Ringing. As discussed earlier, the incident HEMP pulse is a broadband signal with a time waveform approximated by very fast risetime and exponential decay. If all coupling paths had broadband frequency responses, EMP-induced transients would show similar waveforms. However, inductance, capacitance, and resistance are inherent in any cable, cable shielding, and grounding system, and give rise to frequency dependence. Any LRC system will have characteristic resonant frequencies. EMP-induced transients thus will

EP 1110-3-2
31 Dec 90

tend to oscillate, or "ring," at these dominant frequencies, with the decay rate of the oscillation ruled by the width of the resonance in the frequency domain (fig 2-25). A very narrow resonance can cause a long-lived oscillation. This increased energy is added to the system and the likelihood of damage increases. Typical ringing frequencies range from 1 to 15 megahertz, depending on the physical and electrical details of the shielding and grounding systems.

(i) Conductive penetrations. Pipes and other penetrators with nonelectrical functions act very much like the shield of a shielded cable. Most often such penetrators are buried. For these buried conductors, transmission line theory can be used to calculate HEMP coupling, with the soil acting as the return path. Both nonelectric penetrators and components with an electrical function can couple EMP energy by acting in a mode other than that for which they were designed. For example, waveguides usually are designed to guide waves of a much higher frequency than HEMP; however, currents can be coupled onto the exterior of waveguides and conducted to the sensitive equipment. Conductive penetrations not only can collect HEMP energy, they also can serve as low-impedance paths to ground for currents induced elsewhere in a facility.

(3) Intrasite cables. Intrasite or internal cables at a structure may connect to mission-essential equipment. EMP-induced transients on these cables result partly from direct interaction with EMP fields that reach the structure's interior. These internal EMP fields couple to long, internal cable runs and internal cable loops (fig 2-26). EMP-induced transients on internal cables may also result from "cross talk." Typically, a cable that penetrates a facility will branch into many smaller cables (e.g., low-current power cables, individual telephone lines). These penetrators run alongside other internal cables so that penetrating EMP-induced transients tend to be shared. This especially occurs when cables run together in the same cable tray or conduit, but it can also happen to some degree if the cables pass within a few meters of each other. The result is that all cables linked to a piece of mission-essential equipment must be seen as potential sources of harmful voltage and currents. Figure 2-27 shows the distribution of currents at equipment leads for a typical unshielded telephone communications facility when subjected to a 50-kilovolt per meter EMP, polarized 16 degrees from the horizontal and coming from a worst-case direction. The structure has an incoming power line on which a peak current of 4 kiloamps is seen. Nineteen waveguides with a total peak current of 5 kiloamps also penetrate the structure. The waveguides come from a microwave tower and are grounded as they enter the structure.

2-5. Equipment susceptibility. System damage or upset from EMP is caused by currents and voltages induced in conductors exposed to a free-field or a

*The narrow resonance results from circuits of high Q (quality factor) which have low resistive dissipation of energy.

partly attenuated EM pulse coupled to circuits. External conductors, structures, and internal conductors act as unintentional receiving antennas and "coupling" paths. They can deliver the resulting EMP-induced currents and voltages to sensitive components of electronic equipment. The HEMP-induced currents on exterior long-line penetrators, such as power and telephone lines, can have amplitudes as high as thousands of amperes. Currents induced on internal cable runs can be as high as hundreds of amperes for most structures and even higher in facilities with lower SE. It is important to note that exterior voltage transients can be in the megavolt range, and it would be normal to expect an order of thousands of volts from internal coupling. Transients of these magnitudes can be delivered to electronic circuits, such as integrated semiconductor circuits, which can be damaged by only a few tens of volts, a few amperes, or less. These circuits also operate at relatively low levels (e.g., 5 volts and tens of milliamperes) and can be upset by EMP currents of similar values. If the large exterior coupled transients were allowed to enter a structure that had no HEMP protection treatment, even relatively "hard" devices, such as relay coils and radio frequency interference (RFI) filters, would likely be damaged. Figure 2-28 shows this potential EMP interaction leading to mission degradation.

a. Equipment response. HEMP produces two distinct responses by equipment and system components: upset and damage. Upset is a nonpermanent change in system operation that is self-correcting or reversible by automatic or manual means. Damage is an unacceptable permanent change in one or more system parts. The spectrum of thresholds for some system components is shown in figure 2-29. The figure clearly shows that semiconductors are highly susceptible to HEMP and thus need protection.

(1) Upset. Transient upset has a threshold about one order of magnitude below the damage thresholds. It occurs when an induced HEMP transient exceeds the operating signal level. It has a time scale that falls within the circuit's time response. Figure 2-30 shows some examples of upset. Figure 2-30(a) shows a flip-flop changing state due to a HEMP transient on the trigger input. Figure 2-30(b) shows a NAND gate with a temporary change in its output logic level from a HEMP transient on the power supply line. Figure 2-30(c) shows an amplifier driven to saturation by a HEMP transient superimposed on its signal input.

(2) Damage.

(a) Semiconductors. Damage to semiconductors due to applied transients is typically some form of thermal-related failure and therefore is related to the total energy applied to the device. For discrete devices (transistors, diodes), the predominant failure mode appears to be localized melting across the junction. The melted regions form resistive paths across the junction which short out the junction or mask any other junction action (ref 2-7). Metallization burnout resulting in open circuits has also been identified as a failure mode in integrated circuits (ref 2-8). A convenient

EP 1110-3-2
31 Dec 90

approach for failure analysis is the concept of the power failure threshold (P_{th}) (ref 2-1). The power failure threshold is defined as--

$$P_{th} = At^{-b} \quad (\text{eq 2-8})$$

where A is the damage constant based on the device material and geometry, and b is the time-dependence constant. The constants A and b can be determined empirically for every device of interest by the least-squares curve fit to experimental pulse test data. In general, it will be more convenient to use the Wunsch model (ref 2-7) for the power failure threshold with previously determined values of the Wunsch model damage constant for any analysis. This theoretical model has a time-dependence constant of $b = 1/2$. Empirical data for a wide range of devices fits the model within the experimental data spread in the midrange of pulse widths, approximately 100 nanoseconds to 100 microseconds (ref 2-1). The Wunsch model theoretical equation is--

$$P_{th} = Kt^{-1/2} \text{ Kw/cm}^2 \quad (\text{eq 2-9})$$

where t is the pulse width in microseconds and K is the Wunsch model damage constant in $\text{kW} - (\text{microsecond})^{1/2}$. K is expressed in these units since the numerical value of K is then equal to the power necessary for failure when a 1-microsecond pulse is applied to the junction. Figures 2-31 and 2-32 show typical ranges for K for various semiconductors. Multiplication of this factor by $t^{-1/2}$ will yield the pulse power threshold.

(b) Passive elements. The passive elements most susceptible to damage from HEMP-induced currents are those with very low voltage or power ratings and precision components for which a small change is significant. Resistor failures due to high-level pulsed currents are caused by energy-induced thermal overstress and voltage breakdown. Resistor failure threshold can be calculated from the resistor's parameters and the empirical relation given in reference 2-9. Exposure of capacitors to transient currents sets up a voltage across the capacitor that increases with time. For nonelectrolytic capacitors, this voltage keeps rising until the capacitor's dielectric breakdown level is reached. That point is typically 10 times the d.c. voltage rating. For electrolytic capacitors, the voltage relationship holds until the zener level of the dielectric is reached. After that, damage can occur. The damage threshold for electrolytic capacitors in the positive direction is 3 to 10 times their d.c. voltage rating. For the negative direction it is one-half their positive failure voltage (ref 2-10). Transformer and coil damage due to HEMP-induced currents results from electric breakdown of the insulation. The pulse-breakdown voltage is typically 5500 volts for power supply transformers and 2750 volts for small signal transformers (ref 2-11).

b. Equipment sensitivity. Localizing responses of specific circuits or components within equipment or a system often is not possible for complex equipment. Therefore, when estimating system response, it is often more

EP 1110-3-2
31 Dec 90

realistic to deal with the thresholds at the equipment level instead of at the circuit or component level. Using the equipment thresholds approach usually requires that the applicable systems have had their thresholds analyzed or measured. Measured thresholds for some types of communications equipment are given in table 2-3.

c. Typical damage and upset levels. Table 2-4 gives typical HEMP-induced transient levels as observed in tests and analyses at operational facilities. The largest voltage value is 2 megavolts and the largest current is 4 kiloamps. Much smaller values may also result. This is especially true for the inner conductor of the coaxial line because of the shielding protection provided by the outer conductor. The data in Table 2-4 were obtained with the equipment under test in a parallel plate EMP simulator. The simulator excitation approximated the 50-kilo-volt/meter double exponential waveform with risetime of 5 to 10 nanoseconds and e-fold of approximately 0.5 microseconds. A current probe was then used to measure the peak-to-peak current on a power supply lead. The current measured was typically a damped sinusoid with frequency dependent on equipment type and lead length.

2-6. Cited references.

2-1. DNA EMP Course Study Guide, draft prepared for Defense Nuclear Agency (The BDM Corporation, April 1983).

2-2. Ghose, Rabindra N., EMP Environment and System Hardness Design, Library of Congress Catalog Card Number 83-51062 (Don White Consultants, Inc., Gainesville, VA, 1984).

2-3. DOD-STD-2169, (U) High-Altitude Electromagnetic Pulse (HEMP) Environment (DOD, June 1985) (5).

2-4. Prototype HEMP Design Practice Handbook, prepared for Defense Communications Agency, Contract No. DCA 100-77-C-0040 (IRT Corporation, 31 May 1978).

2-5. EMP Awareness Course Notes, DNA 2772T (HQ, Defense Nuclear Agency, August 1971).

2-6. Lee, K. S. H., EMP Interaction: Principles, Techniques, and Reference Data, AFWL-TR-80-402, (Dikewood Industries, Albuquerque, NM, December 1980).

2-7. Wunsch, D. C., and R. R. Bell, "Determination of Threshold Failure Levels of Semiconductor Diodes and Transistors due to Pulse Voltages," IEEE Transactions on Nuclear Science, NS-15, No. 6 (Institute of Electrical and Electronic Engineers, December 1968).

EP 1110-3-2
31 Dec 90

2-8. Jenkins, C. R., and D. L. Durgin, "EMP Susceptibility of Integrated Circuits," IEEE Transactions on Nuclear Science NS-22, No. 6 (Institute of Electrical and Electronic Engineers, December 1975).

2-9. Tasca, D. M., D. C. Wunsch, and H. Domingos, "Device Degradation by High Amplitude Currents and Response Characteristics of Discrete Resistors," IEEE Transactions on Nuclear Science, NS-22, No. 6 (Institute of Electrical and Electronic Engineers, December 1975).

2-10. Tasca, D. M., H. B. O'Donnell, and S. J. Stokes III, Pulse Power Responses and Damage Characteristics of Capacitors, Final Report, Contract F29601-75-C-0130 (General Electric, December 1976).

2-11. Dunbar, W., and J. Lambert, "Power System Component EMP Malfunction/Damage Threshold," paper presented at DNA EMP Seminar IIRI, Chicago, IL, 14-16 May 1974.

2-7. Uncited references.

DNA EMP Handbook, DNA 2114H-2, Vol 2 (Defense Nuclear Agency, November 1971).

Lee, K. S. H., T. K. Liu, and L. Morins, "EMP Response of Aircraft Antennas," IEEE Transactions on Antenna Properties, AP-26, No. 1 (Institute of Electrical and Electronic Engineers, January 1978).

EMP Design Guidelines for Naval Ship Systems, ITTR NSWC/WOL/TR-75-193, Naval Surface Weapons Center, 22 August 1975.

EMP Engineering and Design Principles, Bell Laboratories, PEM-37 (Lawrence Livermore Laboratory, 1975).

MIL-STD-461C, Electromagnetic Emission and Susceptibility Requirements for the Control of Electromagnetic Interference (DOD, 4 August 1986).

EP 1110-3-2
31 Dec 90

Table 2-1. Important features of EMP environments*

Type	Features	Systems impact
HEMP	Large extent, high amplitude, broad frequency band, plane wave	Most widely specified threat
Surface-burst		
Source region	Large amplitude, limited extent includes varying conductivity, currents	Important for systems which are hard to other nuclear effects
Radiated region	Large amplitude varies inversely with distance	Can supersede HEMP if vertical orientation or low freqs. important
Air-burst		
Source region	Similar to surface-burst	See surface burst
Radiated region	Amplitude less than HEMP	Superseded by HEMP
SGEMP	Very high amplitude and fast rise time	Important for exoatmospheric systems
MHD-EMP	Very low frequency, low amplitude, large extent	May affect long-land or submarine cables

*Source: ref 2-1, DNA EMP Course Study Guide, draft prepared for Defense Nuclear Agency (The BDM Corp., April 1983), p I-51.

EP 1110-3-2
31 Dec 90

Table 2-2. EMP waveform summary*

Type	Peak amplitude	Timeframe
HEMP	50 kV/m	Few nanosec to 200 nanosec
Surface-burst		
Source region	1 MV/m	Few nanosec to 1 microsec
	10 kV/m	1 microsec to 0.1 sec
Radiated region	10 kV/m	1 microsec to 100 microsec
Air-burst		
Source region	Similar to surface-burst	
Radiated region	300 V/m at 5 km, typical (highly dependent on HOB)	10 nanosec to 5 microsec
SGEMP	100 kV/m	Few nanosec to 100 nanosec
MHD-EMP	30 V/km	0.1 sec to 100 sec

*Source: ref 2-1, DNA EMP Course Study Guide, draft prepared for Defense Nuclear Agency (The BDM Corp., April 1983), p I-49.

EP 1110-3-2
31 Dec 90

Table 2-3. Response thresholds*

Equipment	Lead**	Upset level, p-p*** (A)	Damage level, p-p (A)	Max. stress level, p-p (A)
Primary frequency supply (PFS-2A)	-24 V	0.4	---+	-9
A5 channel bank (solid state modem)	-24 V	80	--	150
	input	--	150	150
	gain	--	75	75
Multiplex				
WELMX-1 (tube)	130 V	0.07	--	1
WELMX-2 (solid-state)	-24 V	0.02	60	60
WEMMX-1 (tube)	130 V	2	--	2
WEMMX-2 (solid-state)	-24 V	--	--	50
Wireline entrance link, 3A (amplifier)	-24 V1	1	--	35
100-A protection switch (switching unit)	+24 V	0.2	--	0.9
TM-1 radio-27 V	--	25	25	
L4 cable system				
Trigger A equalizer	-24 V	8	--	110
Protection switch	-24 V	16	--	110
WE TD3 radio	dc power input	50	--	--
WE TH3 radio	dc power input	60	--	--
Farinon FM 2000 radio	dc power input	208	240	--
Lenkurt 778A2 radio	dc power input	35	--	--
Collins MW608D radio	dc power input	50`	--	--

*Source: ref 2-4, Prototype HEMP Design Practice Handbook, prepared for Defense Communications Agency (IRT Corp., Contract No. DCA 100-77-C-0040, May 1978).

**Point where induced current was measured.

***Induced peak-to-peak (damped sinusoid) on indicated lead.

+Data not measured.

EP 1110-3-2
31 Dec 90

Table 2-4. Typical EMP transients and equipment thresholds--
EMP threat level*

Point of entry	Waveform	Voltage	Current	Impedance (ohms)
A.C. power lines, telephone cables (above-ground)	DE**	2 MV	4 kA	500
	DE	2 MV	4 kA	500
External antennas	2-30 MHz DS**	60 kV	1.2 kA	50
Video COAX lines (inner conductor)	1-5 MHz DS5	5 kV	71 A	70
Telephone cable (submarine sheath)	DE	60 kV	1.2 kA	50

*Source: ref 2-1, DNA EMP Course Study Guide, draft prepared for
Defense Nuclear Agency (The BDM Corp., April 1983), p VI-37.
**DE = double exponential; DS = damped sinusoid.

EP 1110-3-2
31 Dec 90

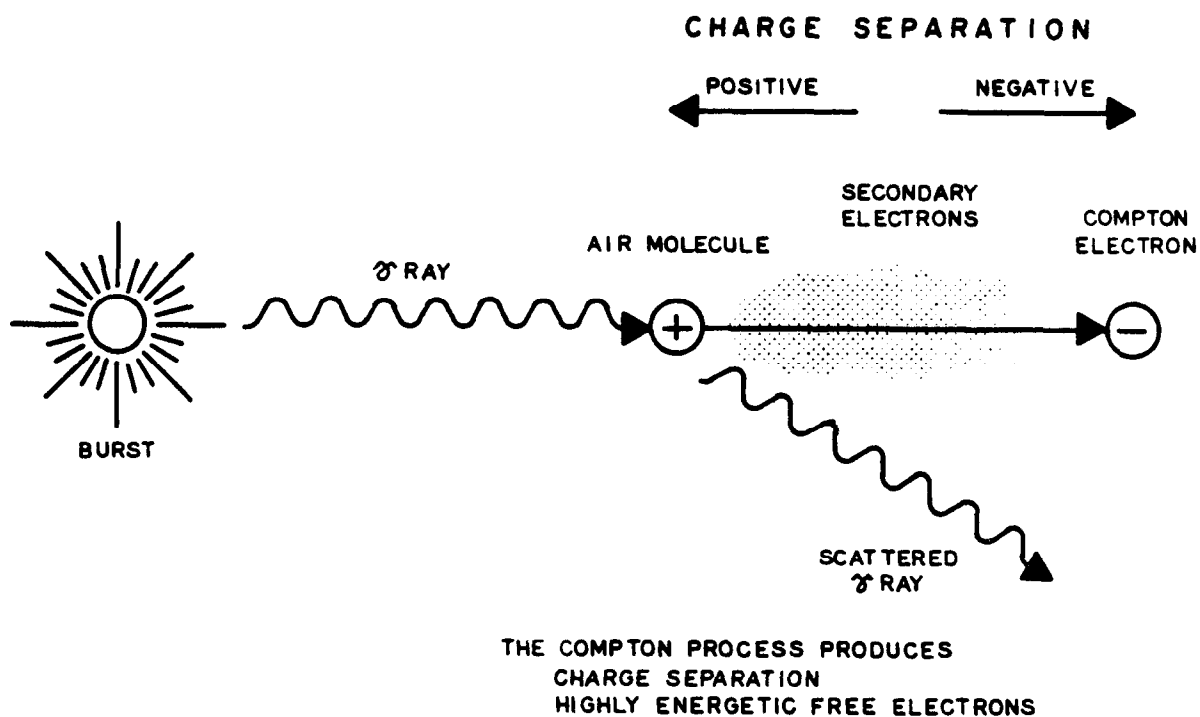


Figure 2-1. The Compton process. (Source: ref 2-1)

EP 1110-3-2
31 Dec 90

This page not used.

EP 1110-3-2
31 Dec 90

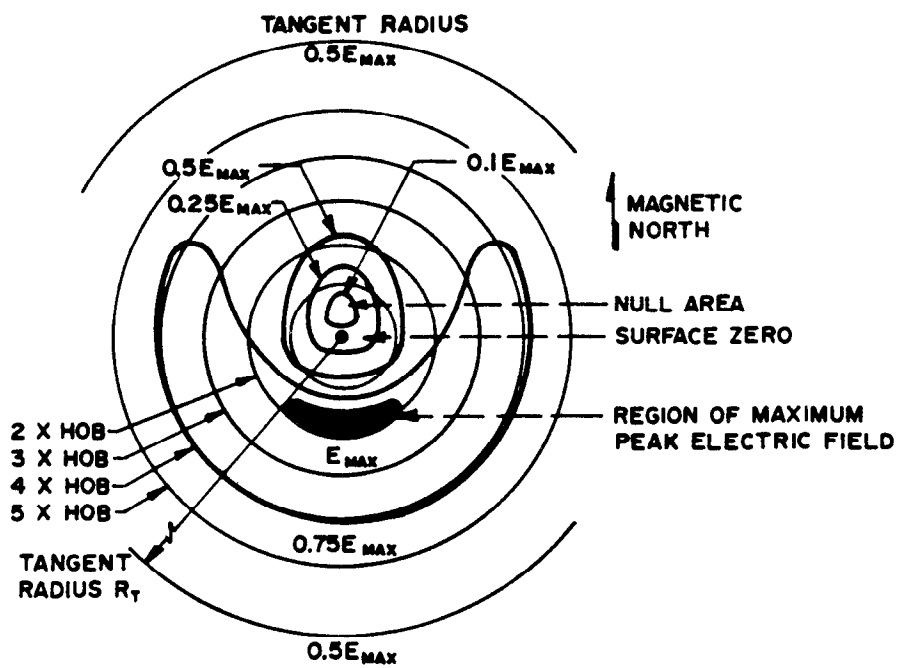


Figure 2-3. Variations in high-altitude EMP peak electric field strength as a function of direction and distance from surface zero.
(Source: ref 2-1)

EP 1110-3-2
31 Dec 90

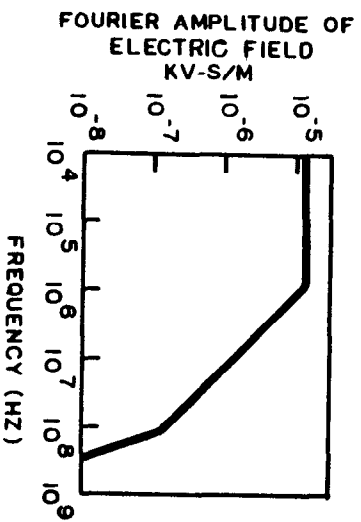
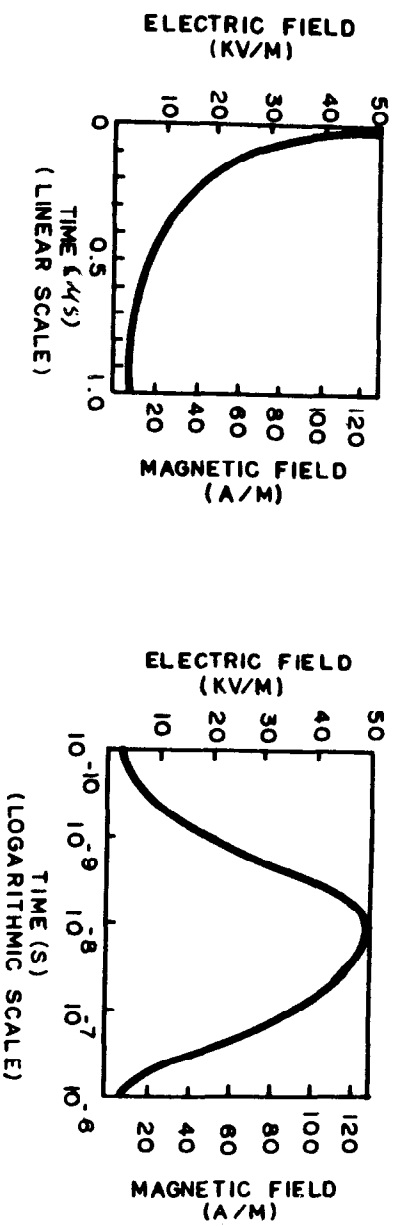


Figure 2-4. HEMP waveform. (Source: ref 2-1)

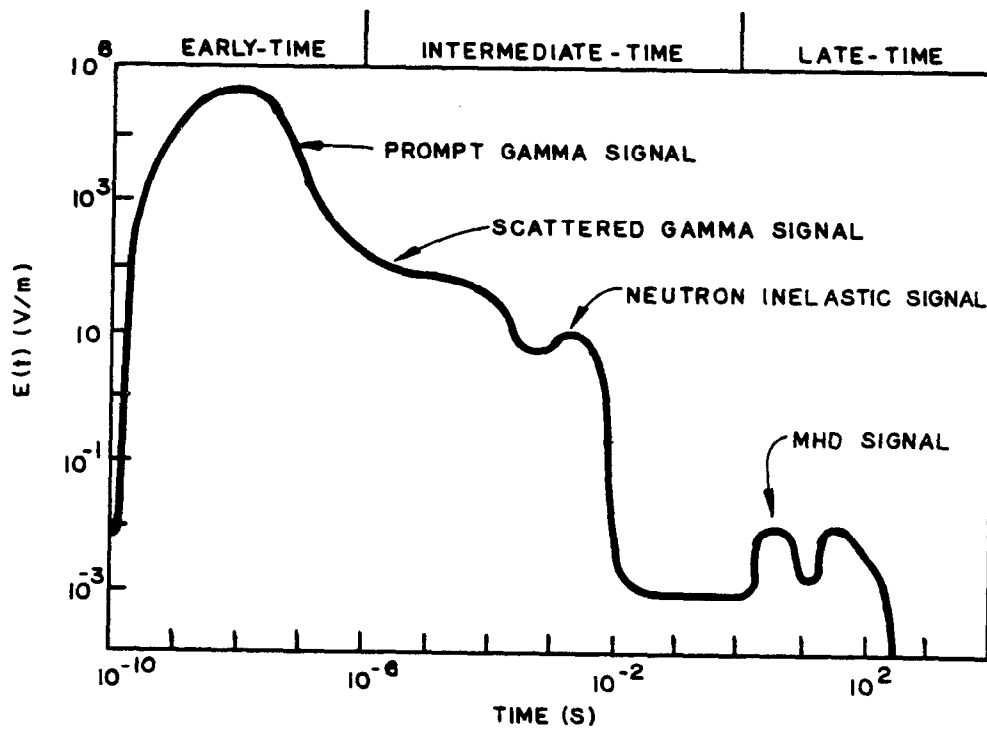
EP 1110-3-2
31 Dec 90

Figure 2-5. Qualitative time domain example of HEMP. (Source: ref 2-1)

EP 1110-3-2
31 Dec 90

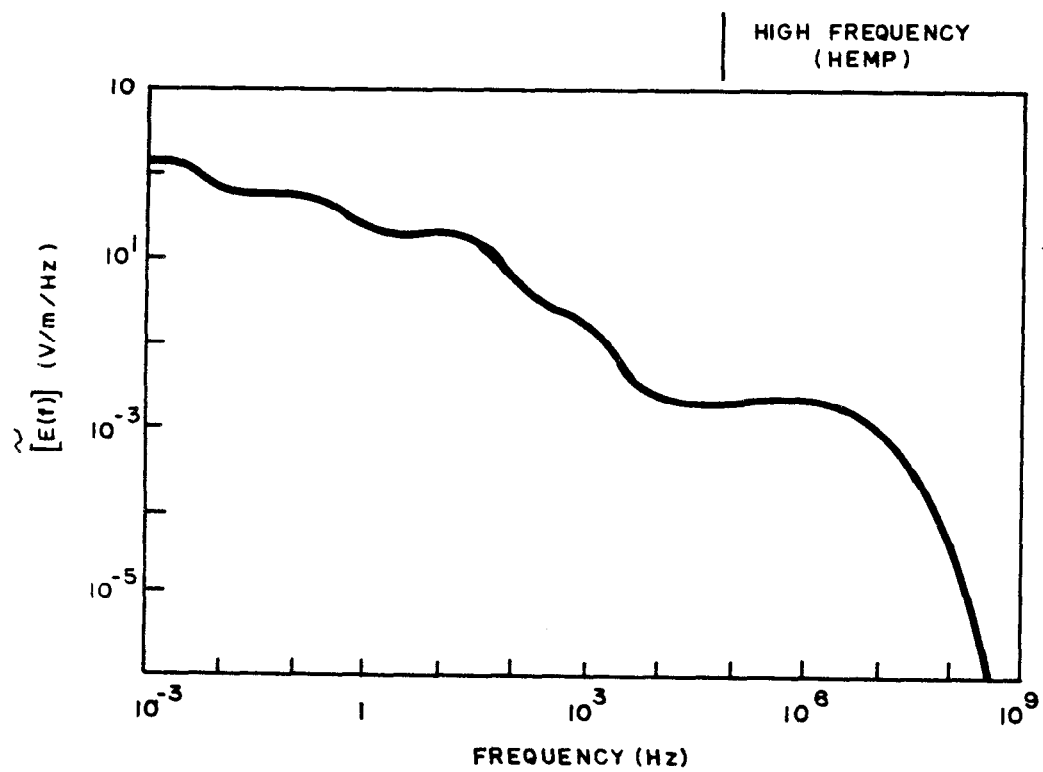


Figure 2-6. Qualitative frequency domain example of HEMP. (Source: ref 2-1)

EP 1110-3-2
31 Dec 90

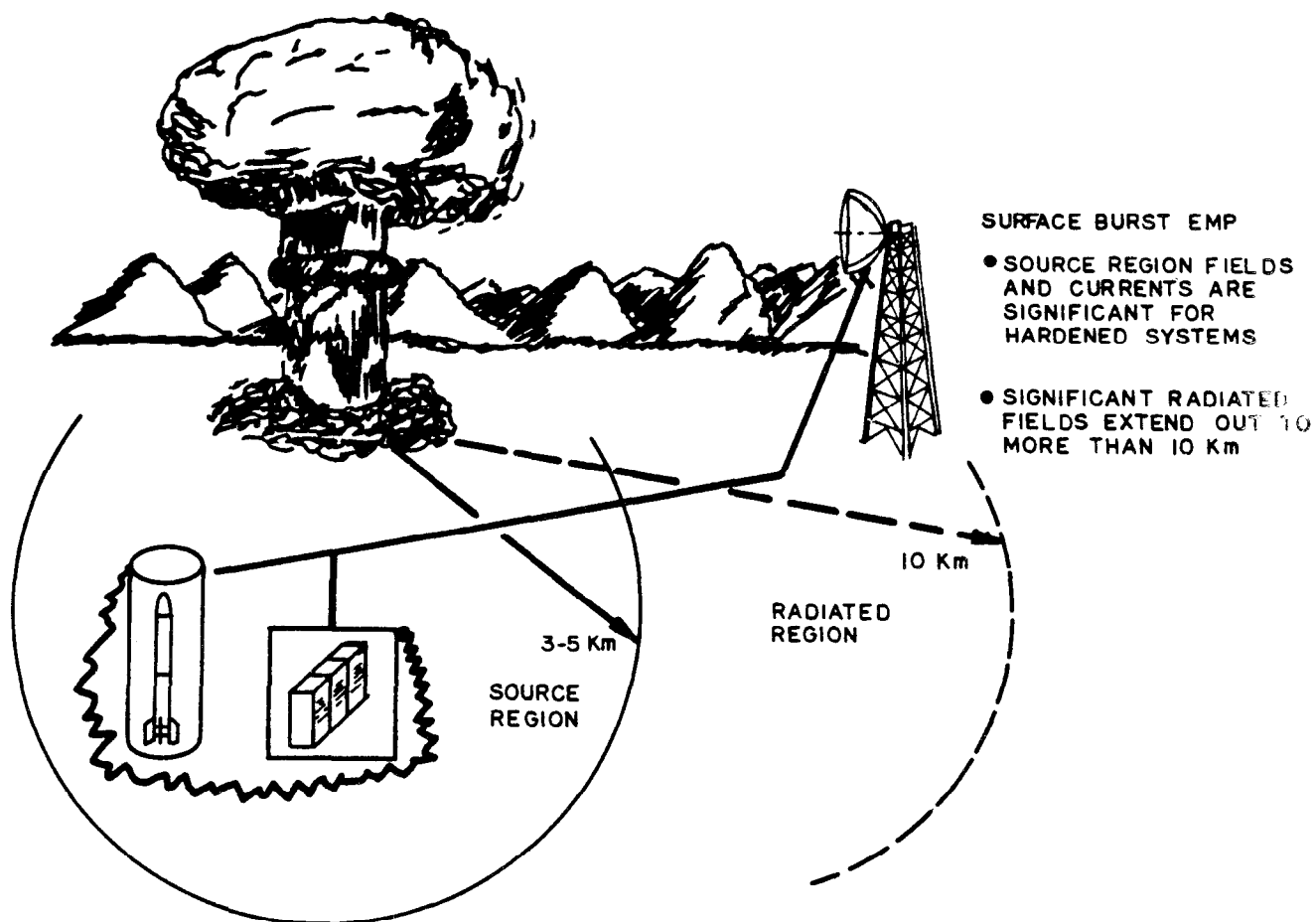


Figure 2-7. Surface-burst EMP showing source region and radiated region.
(Source: ref 2-1)

EP 1110-3-2
31 Dec 90

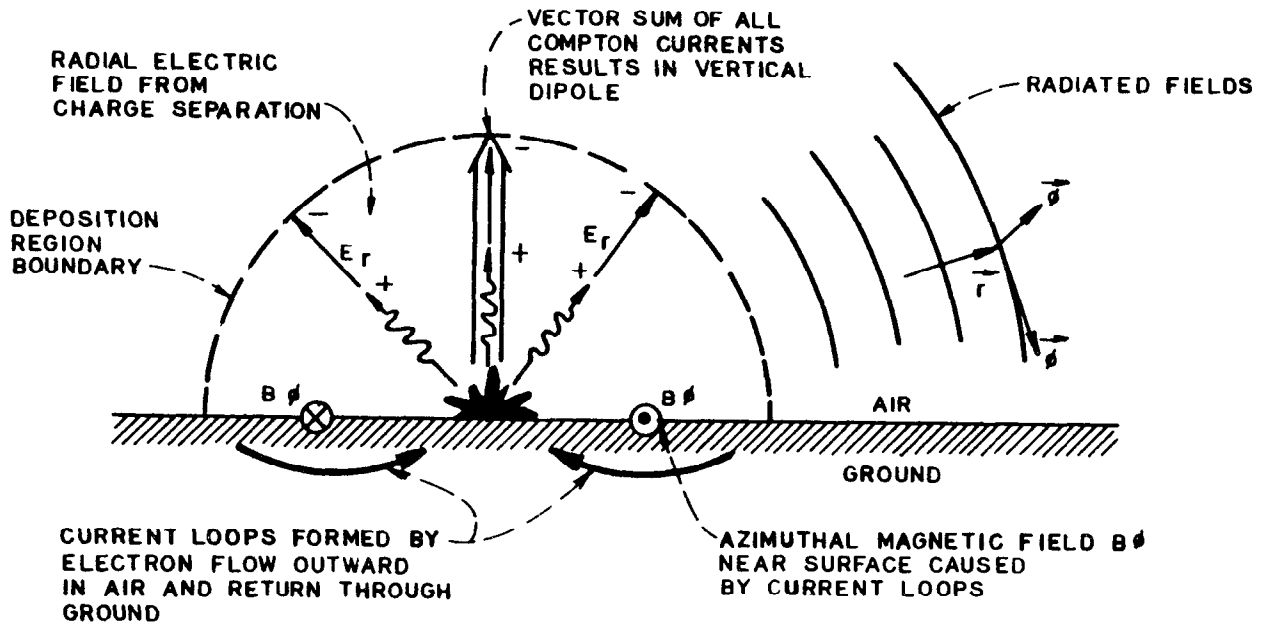
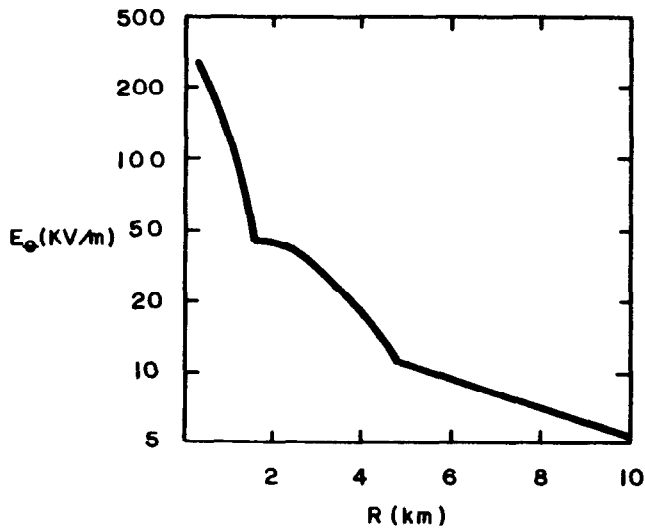


Figure 2-8. Overview of surface-burst EMP. (Source: ref 2-1)

Figure 2-9. Radiated vertical electric field--large surface burst.
(Source: ref 2-1)



- AMPLITUDE TYPICALLY LESS THAN H_{10} IP OUTSIDE SOURCE REGION
- AMPLITUDE VARIES INVERSELY WITH RANGE OUTSIDE SOURCE REGION
- NO STANDARD WAVEFORM
- SYSTEM IMPACT MAY SUPERSEDE HEMP DUE TO
 - HIGH LOW-FREQUENCY CONTENT (BELOW 100 kHz)
 - VERTICAL E-FIELD ORIENTATION

EP 1110-3-2
31 Dec 90

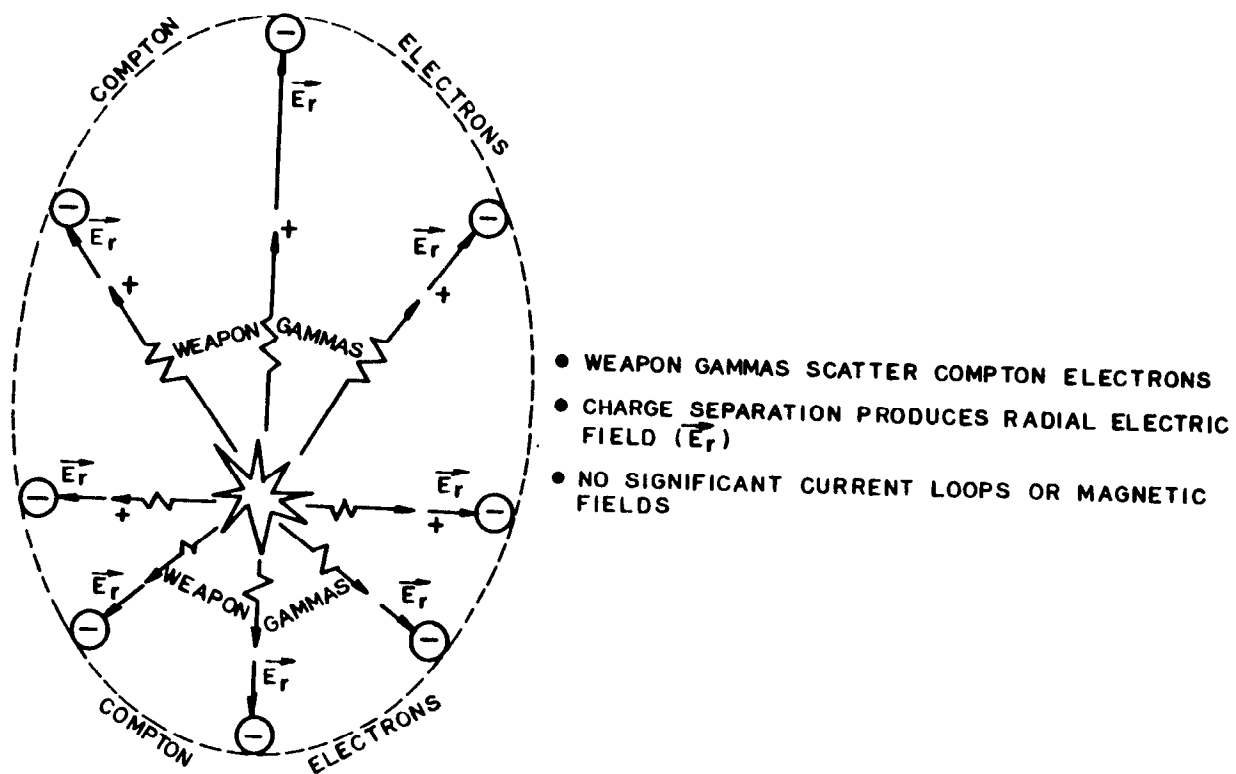
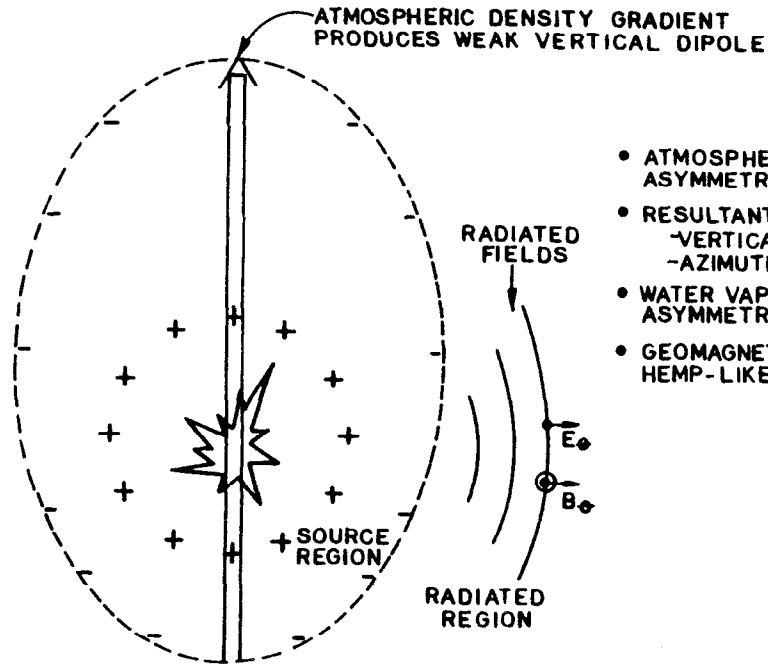


Figure 2-10. Air-burst EMP--source region.

Figure 2-11. Air-burst EMP--radiated region. (Source: ref 2-1)



- ATMOSPHERIC DENSITY GRADIENT RESULTS IN ASYMMETRIC CHARGE DISTRIBUTION
- RESULTANT VERTICAL DIPOLE RADIATES WEAK
-VERTICAL ELECTIC FIELDS (E_{θ})
-AZIMUTHAL MAGNETIC FIELDS (B_{θ})
- WATER VAPOR DENSITY GRADIENT CONTRIBUTES TO ASYMMETRY AND RADIATION
- GEOMAGNETIC TURNING OF COMPTON ELECTRONS ADDS HEMP-LIKE COMPONENT

EP 1110-3-7
31 Dec 90

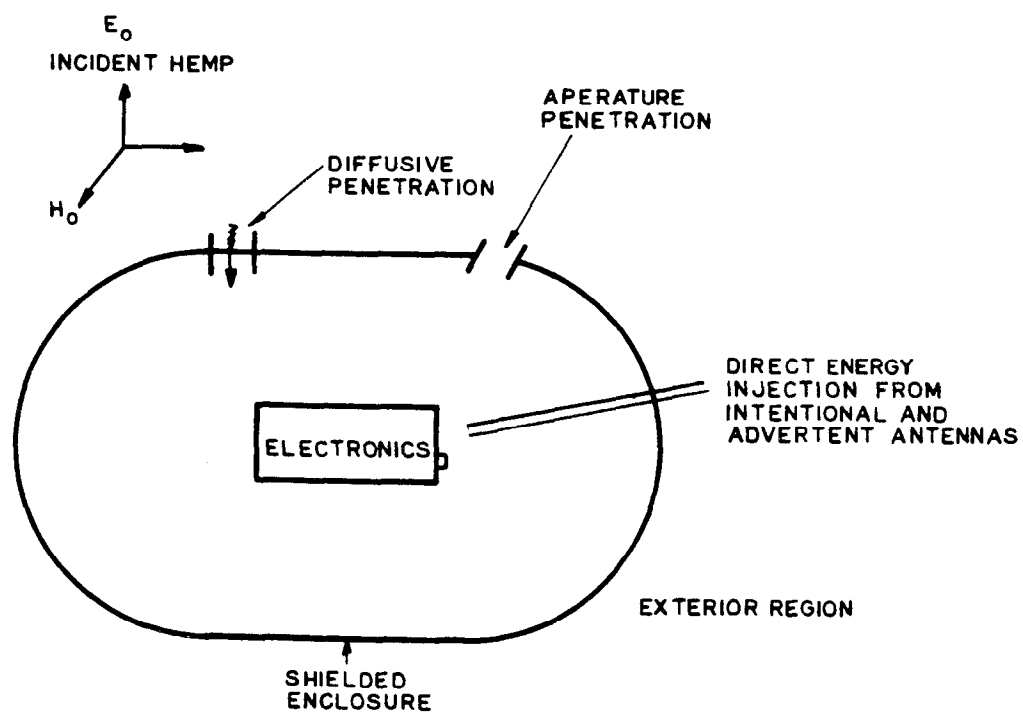


Figure 2-12. Three modes of penetration and coupling into shielded enclosures. (Source: ref 2-4)

EP 1110-3-2
31 Dec 90

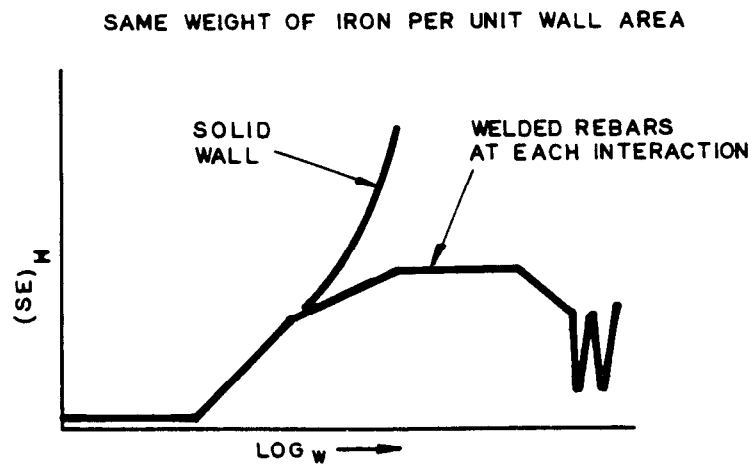


Figure 2-13. Magnetic shielding effectiveness of an enclosure with solid walls and an enclosure with rebar. (Source: ref 2-5)

EP 1110-3-2
31 Dec 90

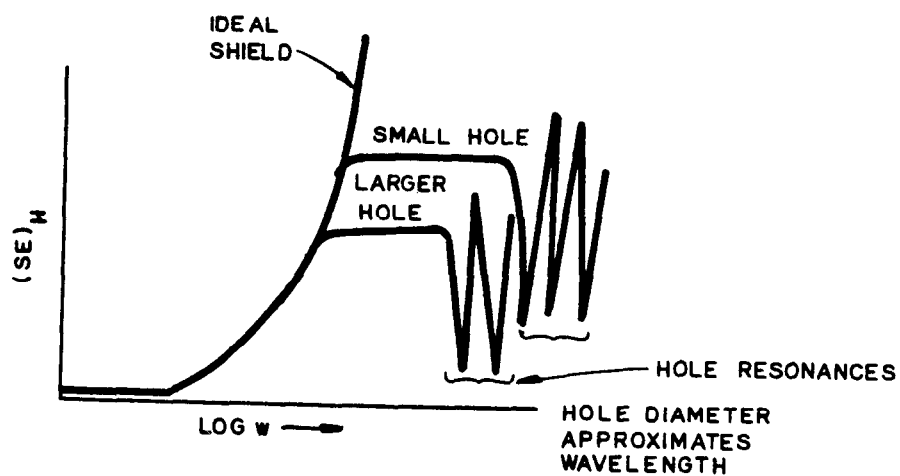


Figure 2-14. Magnetic shielding effectiveness of an ideal enclosure and an enclosure with openings. (Source: ref 2-5)

EP 1110-3-2
31 Dec 90

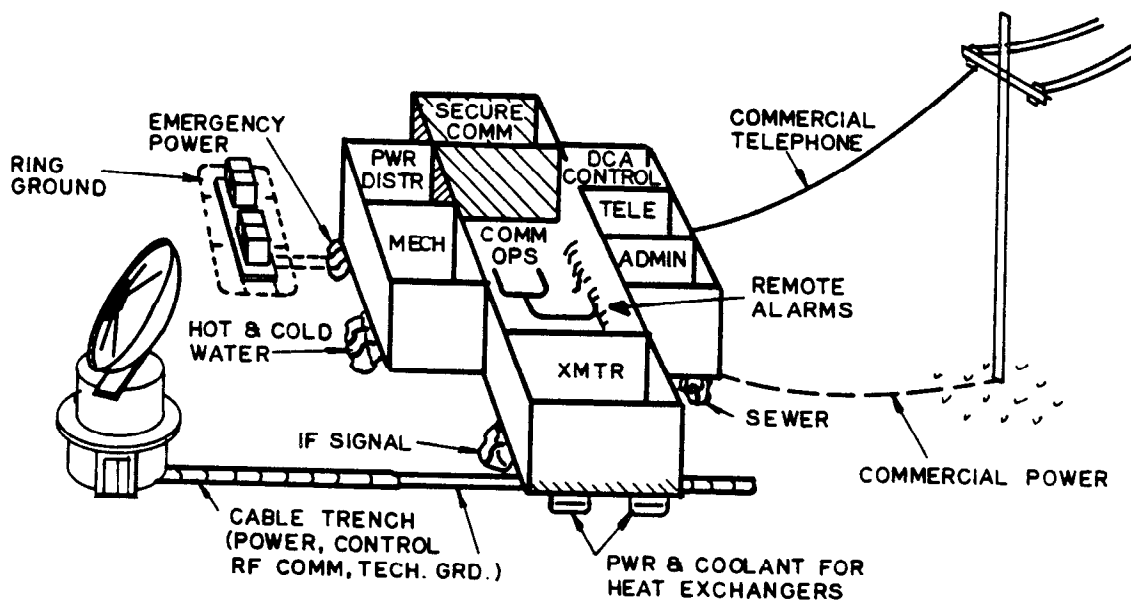


Figure 2-15. Ground-based facilities--unintentional antennas.
(Source: ref 2-1)

EP 1110-3-2
31 Dec 90

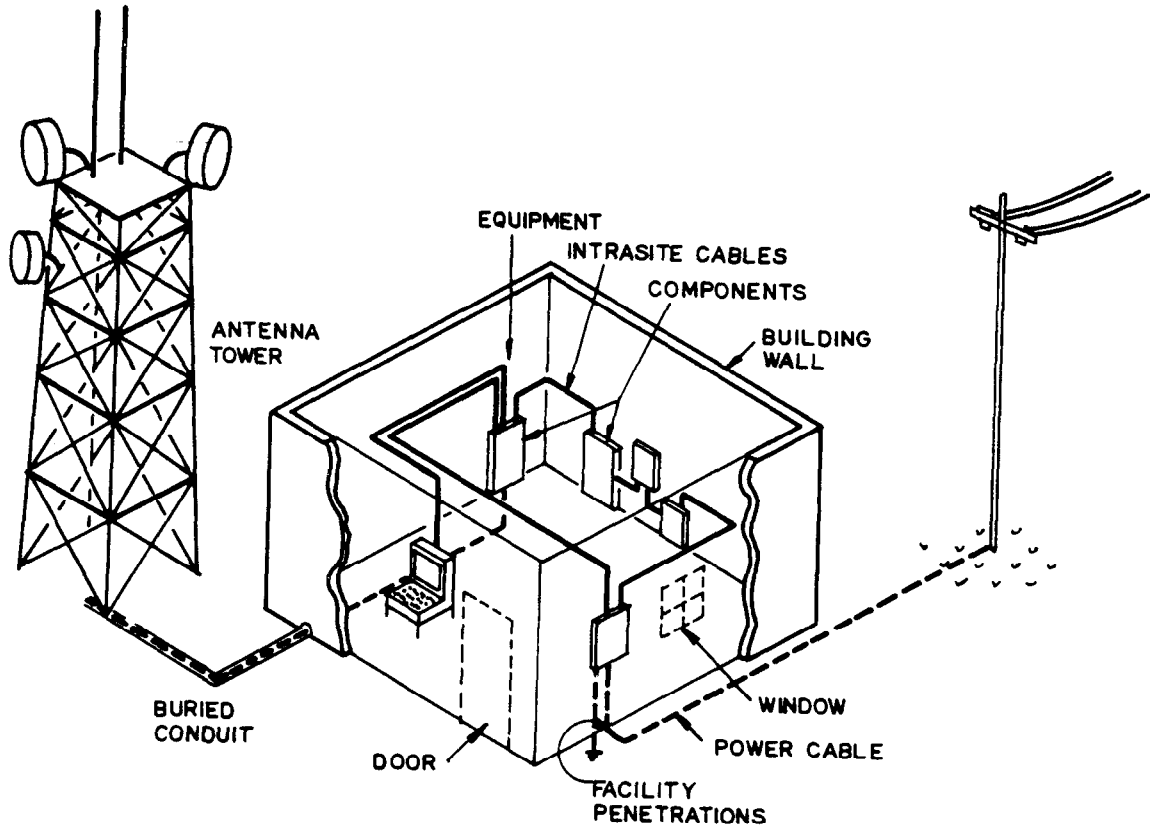


Figure 2-16. EMP coupling to facility penetrations. (Source: ref 2-1)

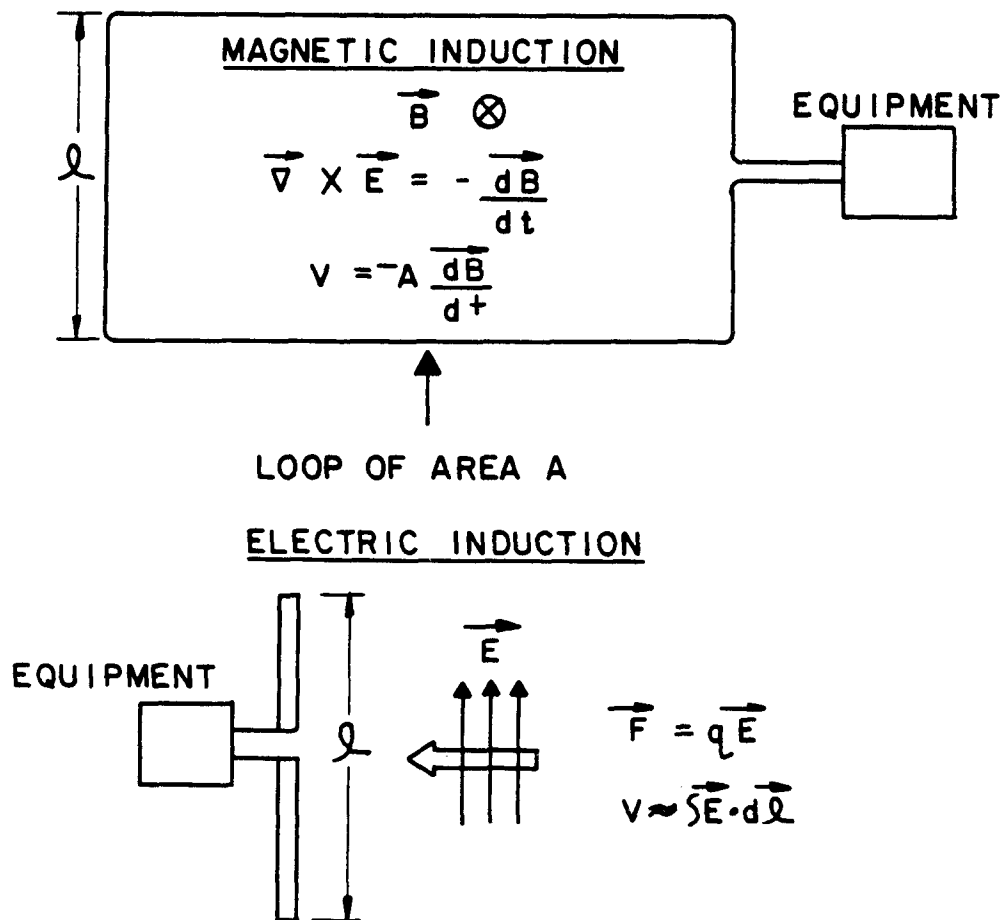


Figure 2-17. Two mechanisms by which EMP couples to conductors.
(Source: ref 2-1)

EP 1110-3-2
31 Dec 90

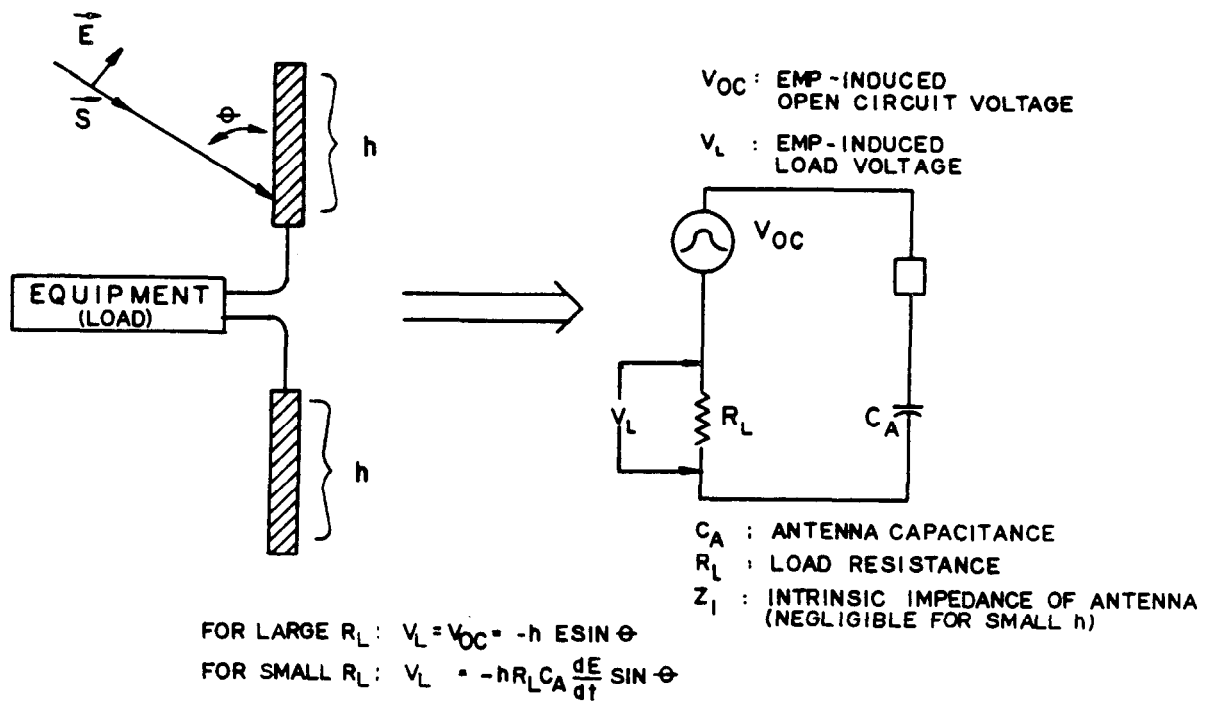


Figure 2-18. Equivalent circuit for a small electric dipole.
(Source: ref 2-1)

EP 1110-3-2
31 Dec 90

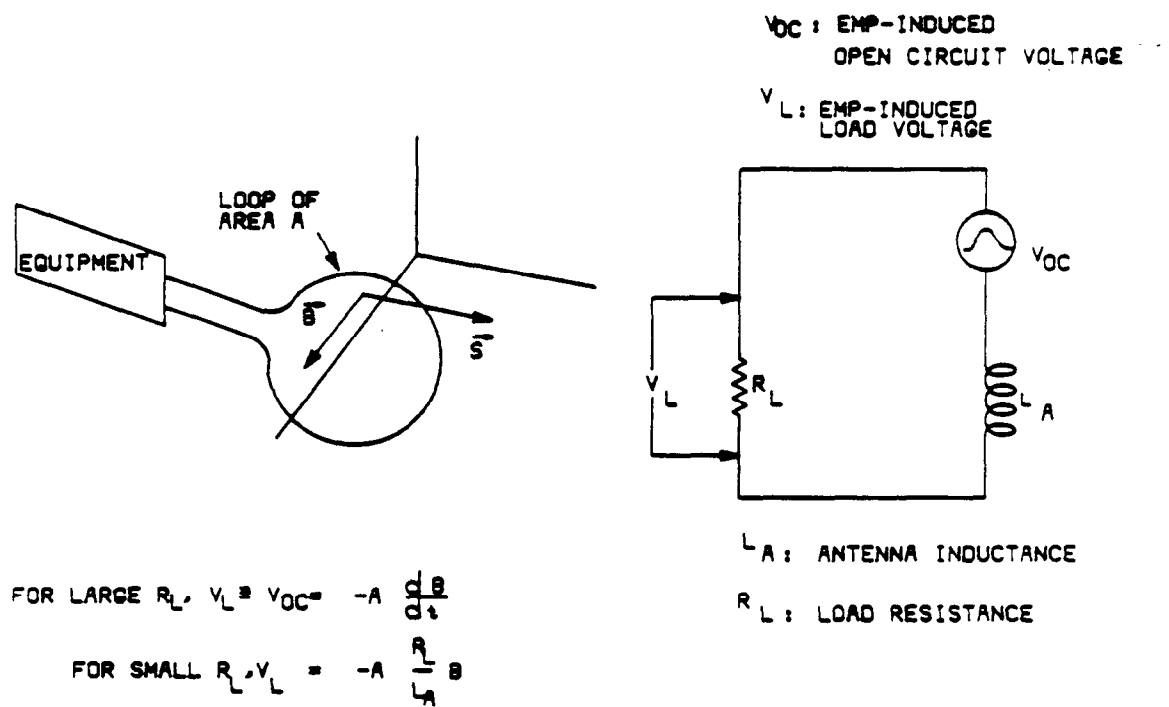


Figure 2-19. Equivalent circuit for a small loop (magnetic dipole).
(Source: ref 2-1)

EP 1110-3-2
31 Dec 90

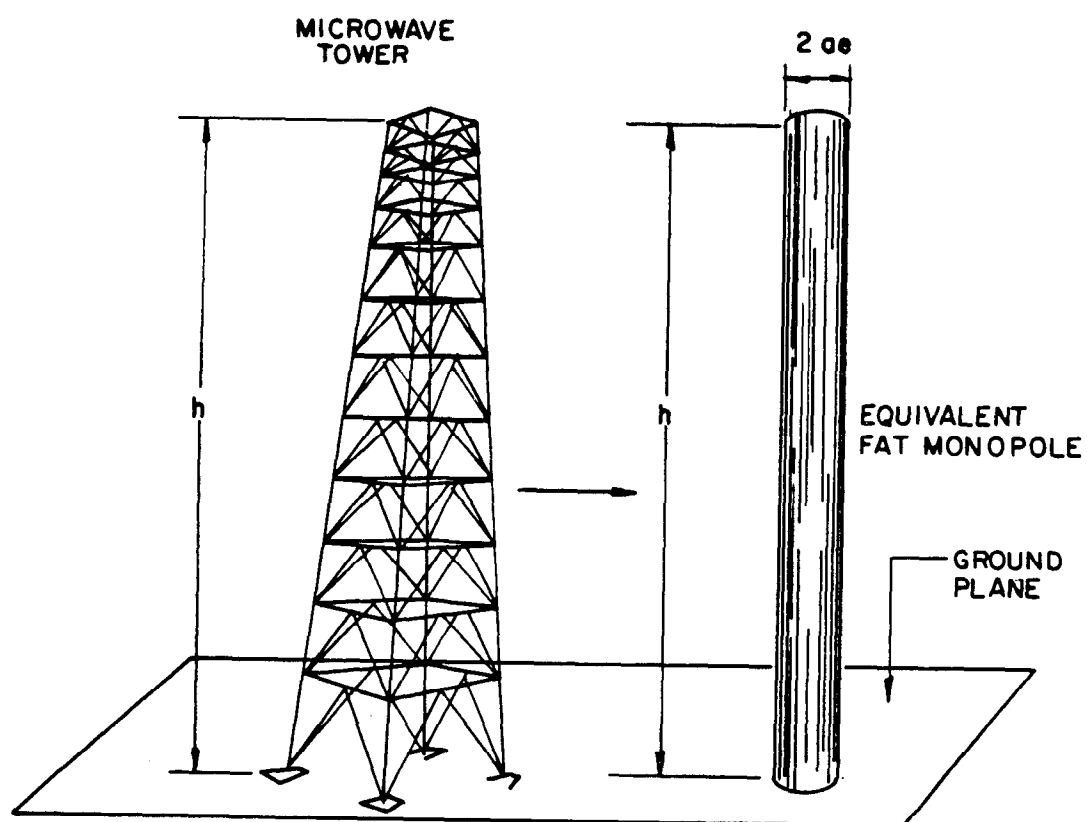
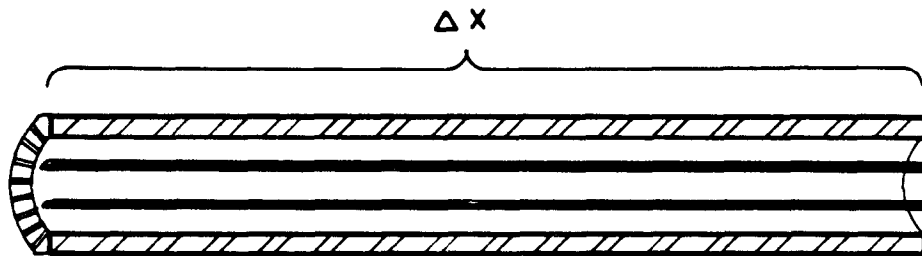


Figure 2-20. Modeling example--microwave tower and equivalent fat cylindrical monopole. (Source: ref 2-1)

EP 1110-3-2
31 Dec 90

$$\Delta V = I_S Z_T \Delta X$$

ΔV = VOLTAGE DROP ON CENTER CONDUCTOR OF CABLE OF LENGTH ΔX

I_S = SHEATH CURRENT

Z_T = TRANSFER IMPEDANCE PER UNIT LENGTH

ΔX = INCREMENTAL LENGTH

Figure 2-21. Shielded cables and transfer impedance. (Source: ref 2-1)

EP 1110-3-2
31 Dec 90

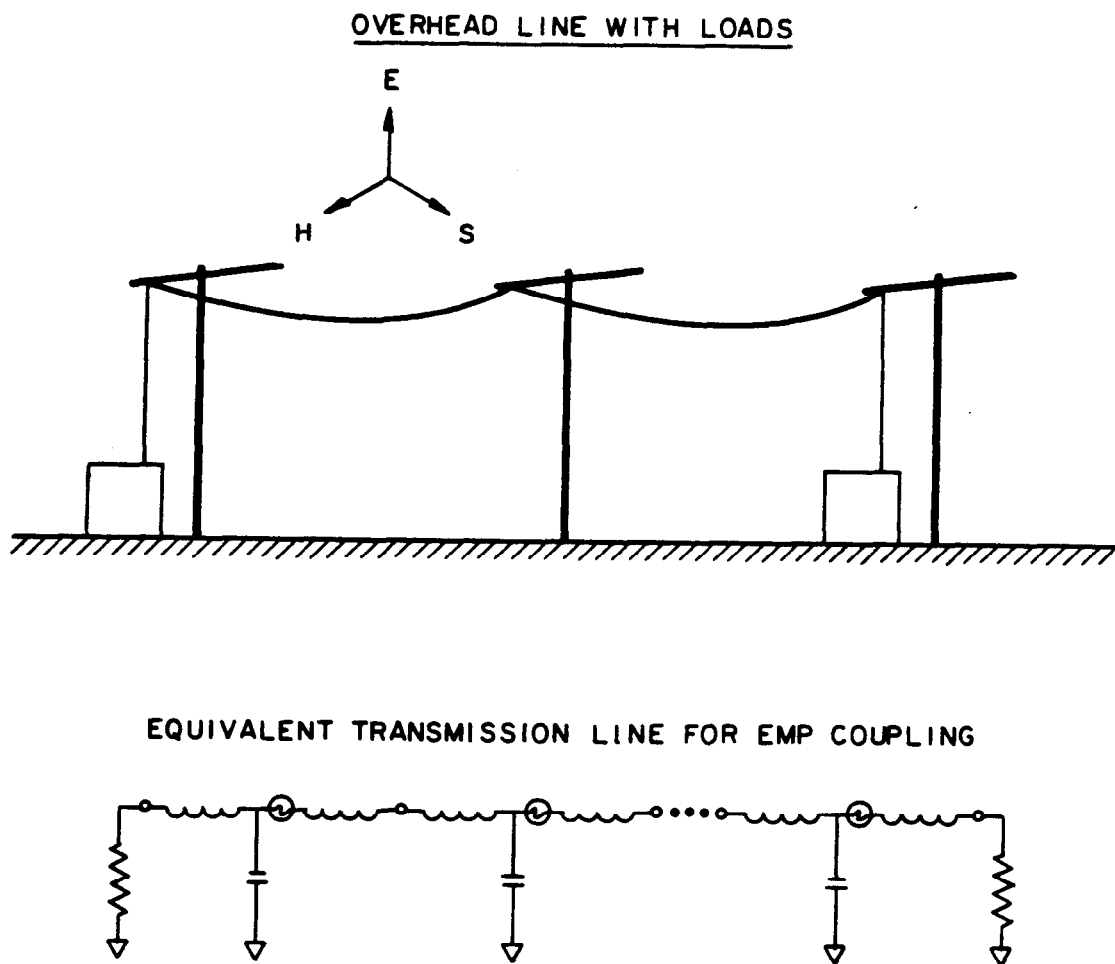


Figure 2-22. Transmission line coupling. (Source: ref 2-1)

EP 1110-3-2
31 Dec 90

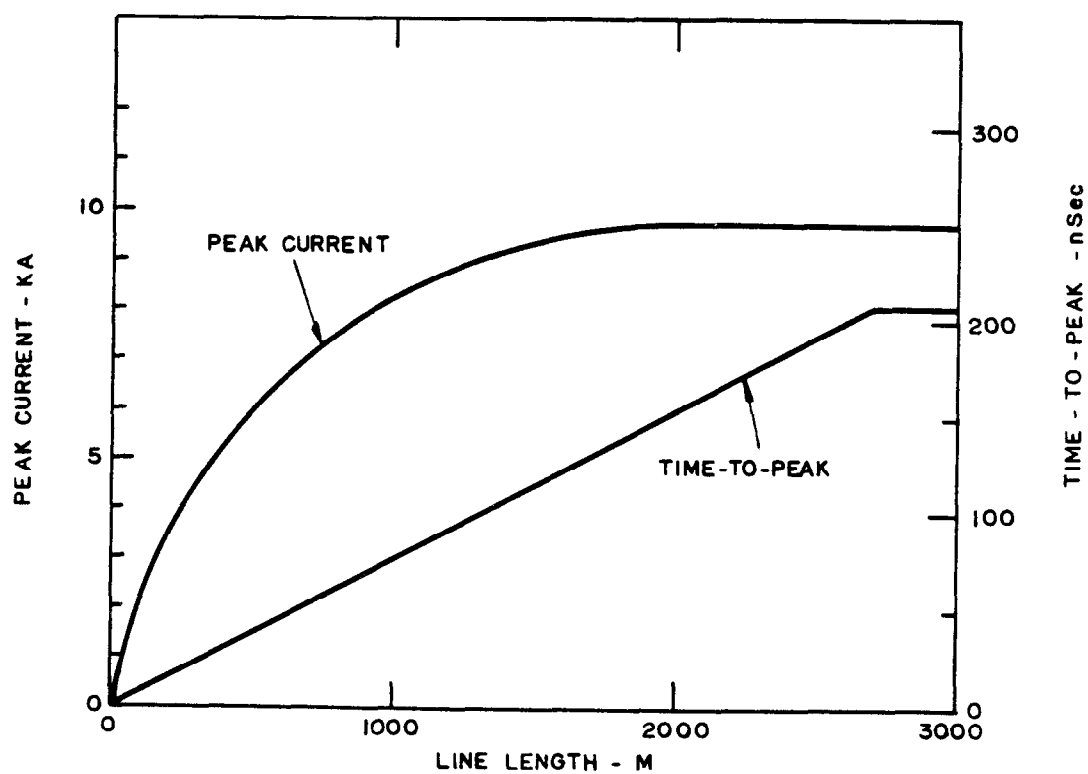


Figure 2-23. Aerial conductors: effect of conductor length.
(Source: ref 2-1)

EP 1110-3-2
31 Dec 90

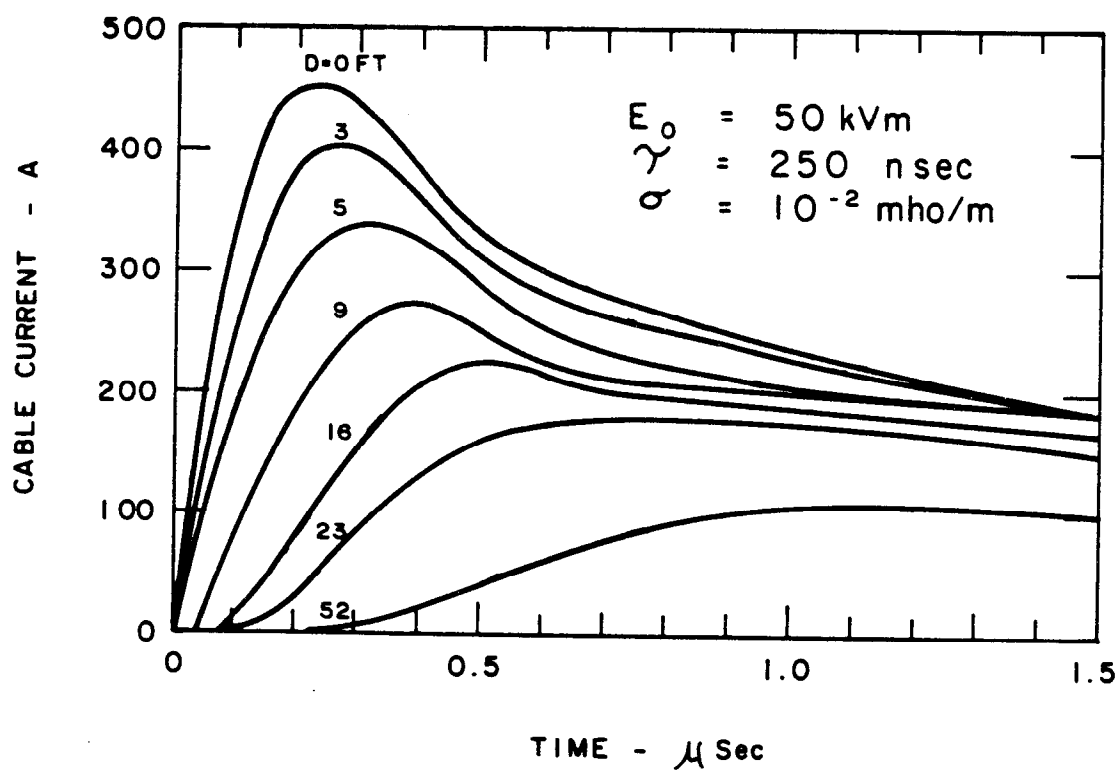


Figure 2-24. Buried conductors: effect of burial depth. (Source: ref 2-1)

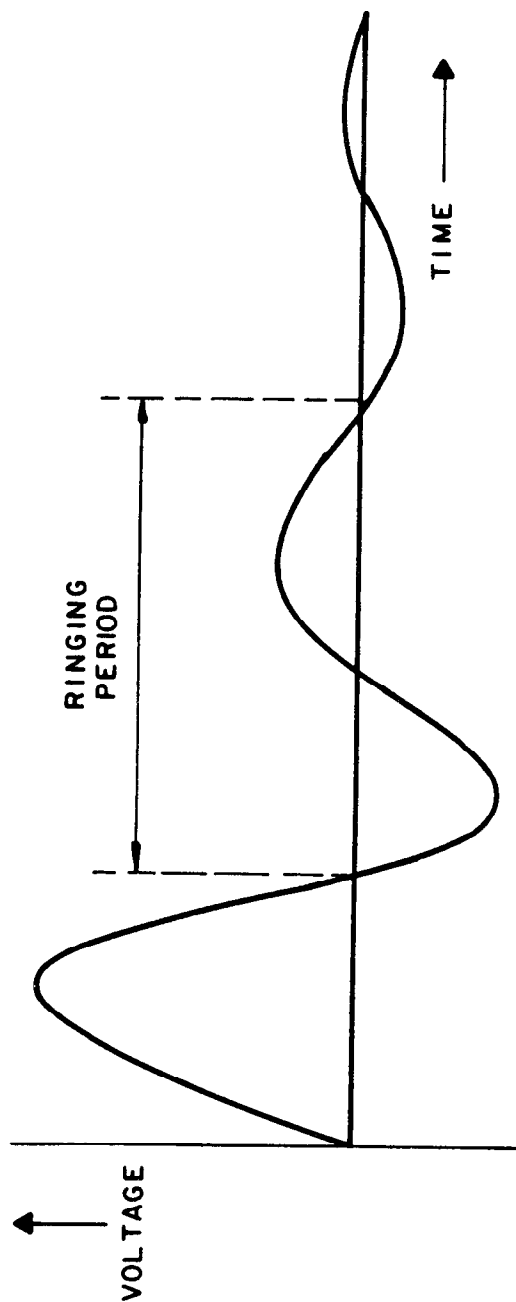


Figure 2-25. Ringing.

EP 1110-3-2
31 Dec 90

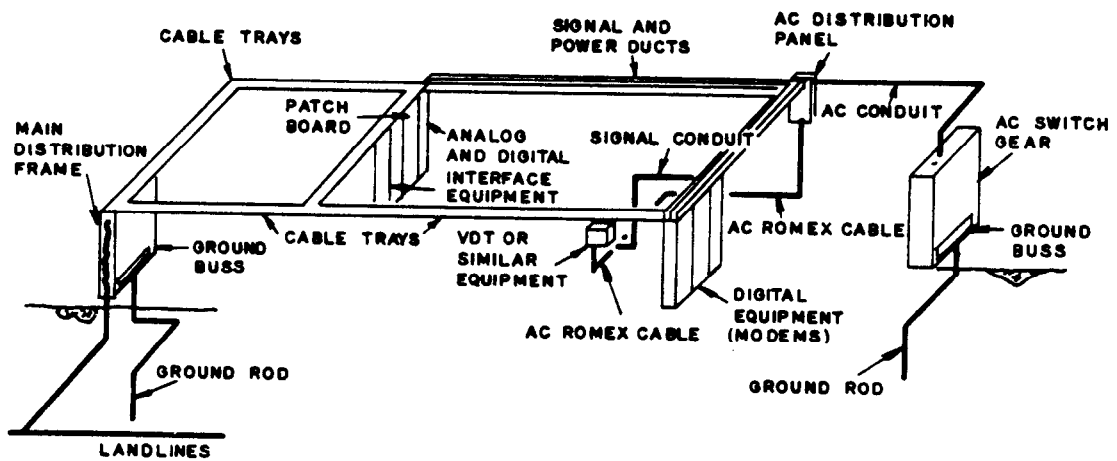


Figure 2-26. Typical internal signal cable distribution diagram.
(Source: ref 2-1)

EP 1110-3-2
31 Dec 90

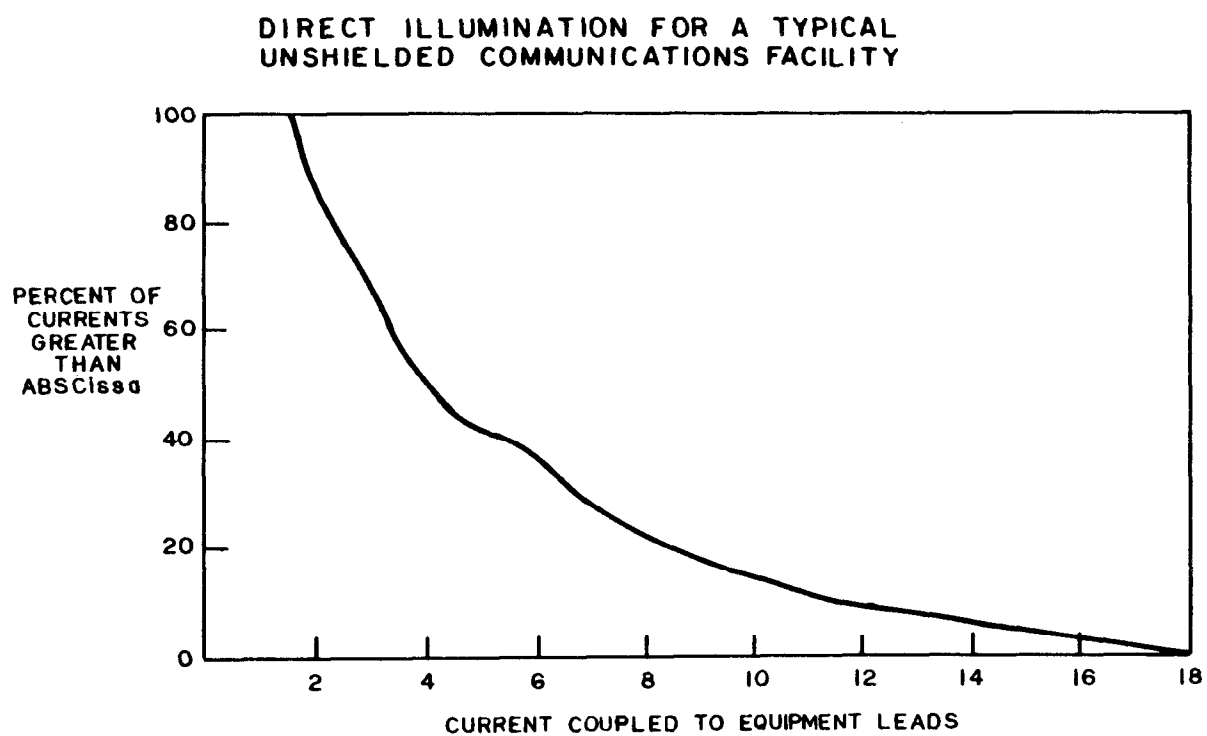


Figure 2-27. Intrasite cables. (Source: ref 2-1)

EP 1110-3-2
31 Dec 90

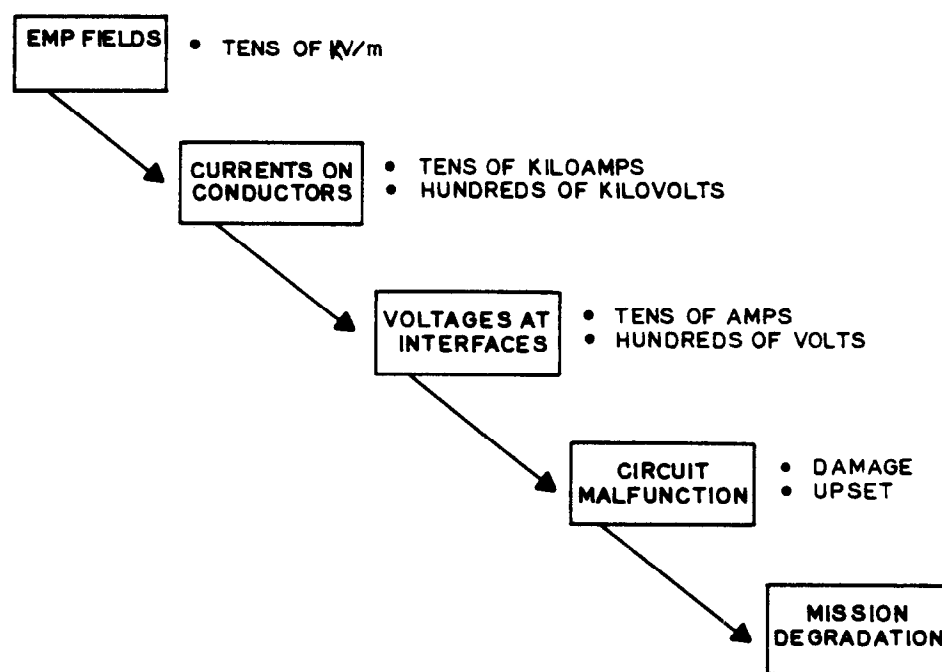


Figure 2-28. EMP system interaction. (Source: ref 2-1)

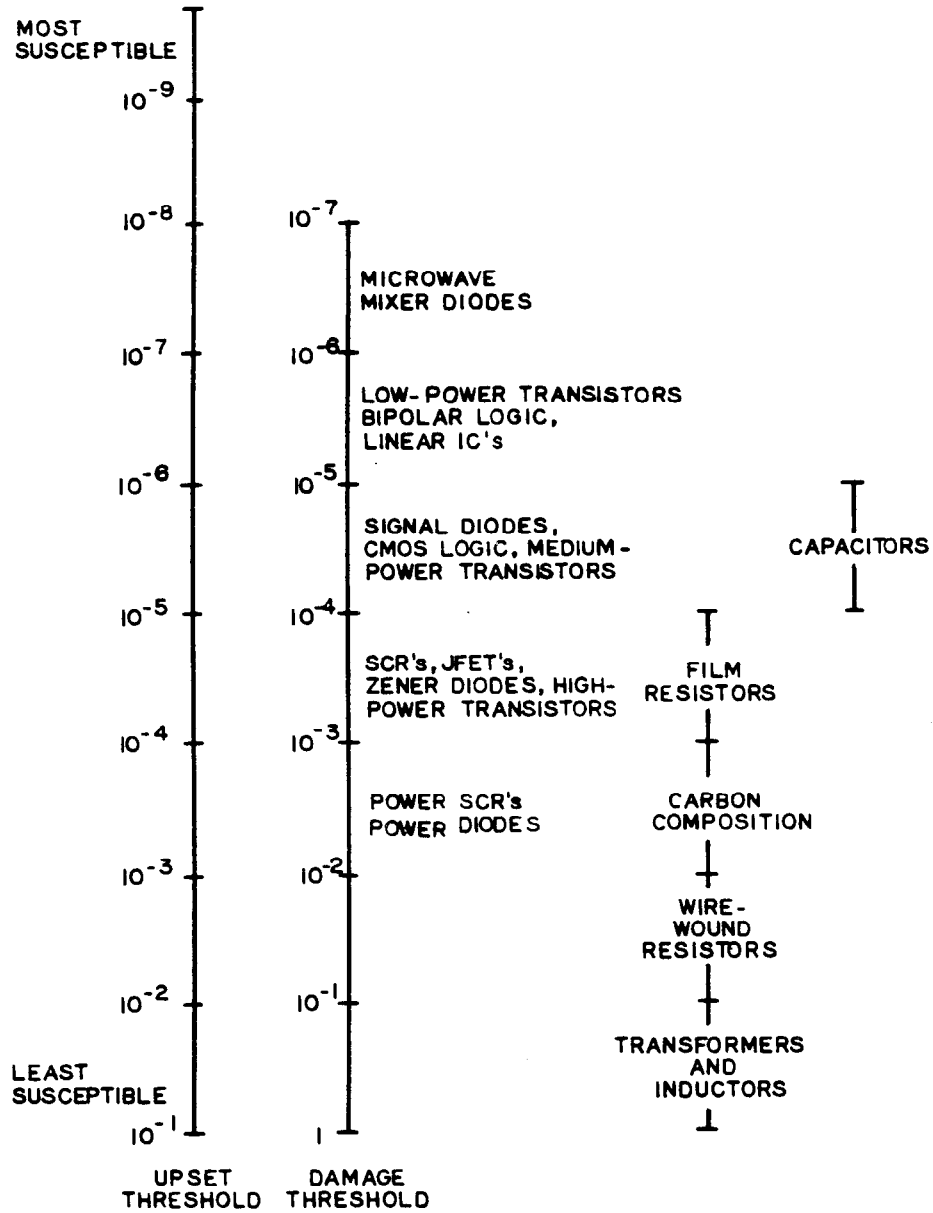
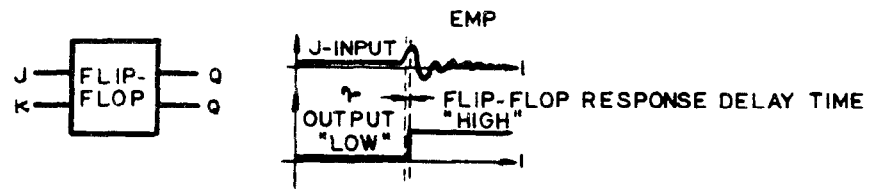
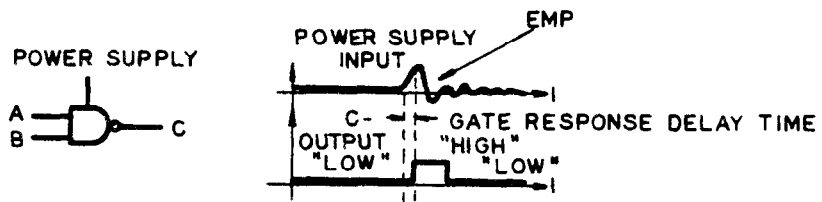


Figure 2-29. Energy level ranges, in joules, that damage various components. (Source: ref 2-4)

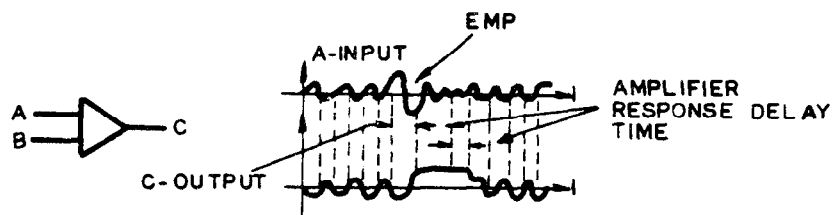
RP 1110-3-2
31 Dec 90



(a) FLIP - FLOP UPSET



(b) NAND GATE UPSET



(c) AMPLIFIER UPSET

Figure 2-30. Examples of transient upset. (Source: ref 2-4)

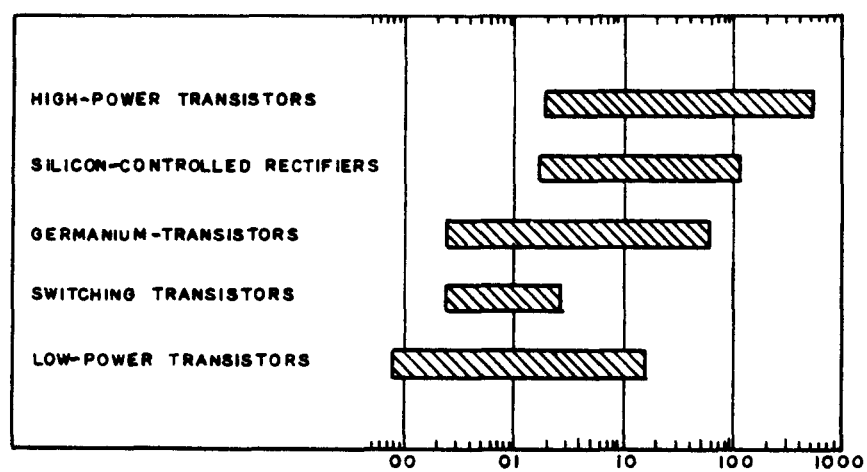
EP 1110-3-2
31 Dec 90

Figure 2-31. Range of pulse power damage constants for representative transistors.
(Source: ref 2-5)

EP 1110-3-2
31 Dec 90

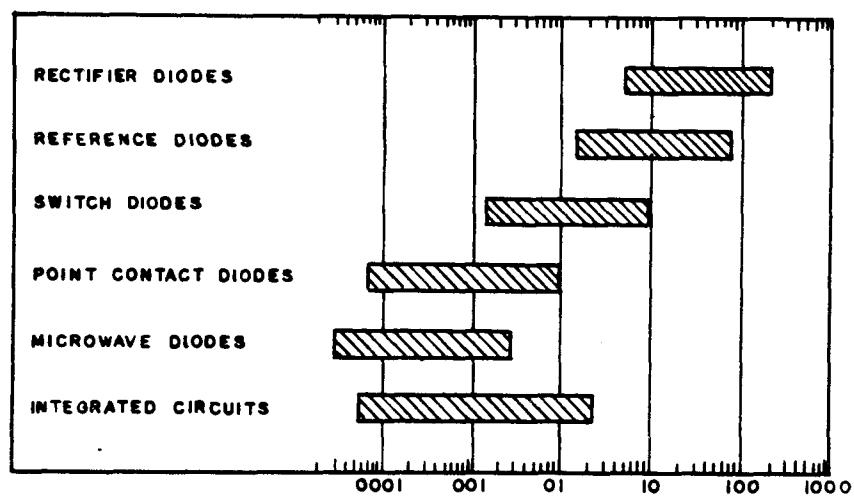


Figure 2-32. Range of pulse power damage constants for representative semiconductors. (Source: ref 2-5)

CHAPTER 3

EMP HARDENING CONCEPTS FOR FACILITIES

3-1. Outline. This chapter is organized as follows:

- 3-1. *Outline*
- 3-2. *Discussion of general concepts*
 - a. *System functions*
 - b. *Survival confidence*
 - (1) *Levels of confidence*
 - (2) *Inherent uncertainties*
 - c. *Critical equipment sensitivities*
 - (1) *Design margin*
 - (2) *Coupled energy*
 - d. *Potential HEMP coupling paths*
 - e. *Design verifiability*
 - (1) *Hardness validation*
 - (2) *Retrofit designs*
 - (3) *Designing to facilitate testing*
 - (4) *Approaches to validation*
 - f. *Physical environment*
 - g. *Other factors*
- 3-3. *Description of HEMP hardening concepts*
 - a. *Shielding*
 - (1) *Global shielding*
 - (2) *Tailored shielding*
 - (3) *Zonal or topological shielding*
 - (4) *System configuration*
 - (5) *Cable shielding*
 - (6) *Grounding*
 - b. *Hardening allocation concept*
 - c. *Shield penetration protection concepts*
 - (1) *Large access doors*
 - (2) *Personnel entrances*
 - (3) *Electrical penetrations*
 - (4) *Transient suppression devices and filters*
 - (5) *Electromagnetic isolation*
 - (6) *Dielectric isolation*
 - (7) *Isolation switching*
- 3-4. *Cited references*
- 3-5. *Uncited references*

3-2. Discussion of general concepts. The HEMP environment is defined by DOD-STD-2169. This definition includes the classification and specific information on field strengths, pulse characteristics, spectral content, angle of arrival, range of relative burst locations, and weapon yield.

EP 1110-3-2
31 Dec 90

a. System functions. Associated with the electronic and electrical systems and subsystems to be protected are support functions such as utilities, personnel housing, office space, document storage, food facilities, and others. Many aspects of a facility are not sensitive to HEMP energy or are robust enough that HEMP protection is not required. Some sensitive system elements may not be critical to the facility mission. The definition of mission-essential functions that must remain in operation will have major impact on the choice of hardening concepts.

b. Survival confidence. The issue of defining "survivability requirements" must be specifically addressed and resolved in the concept definition phase of each particular HEMP hardening effort. The system user should define the required survival confidence level, at least qualitatively, since this factor will determine how conservative the design will be. If required confidence levels are high, greater safety margins in protection levels will be required, producing a need for a high-quality overall shield and adequate validation testing.

(1) Levels of confidence. Survivability confidence may require that a facility--

(a) Experience no HEMP-induced stress greater than the stresses occurring in the normal operating environment.

(b) Experience neither permanent nor operational upset as a result of the HEMP.

(2) Inherent uncertainties. Another survivability issue concerns the inherent and analytical uncertainties in quantifying the stress level causing malfunction or the stress level experienced by the equipment.

c. Critical equipment sensitivities. The main factors in determining required protection levels are--

(1) Design margin. The design margin required, which is related to the difference between critical equipment sensitivities and coupled transients.

(2) Coupled energy. The energy level coupled from connected subsystems or components.

d. Potential HEMP coupling paths. Most electronic/ electrical systems to be HEMP-hardened and their housing facilities will have to interface with external elements such as antennas, utilities, communications lines, and other facilities. The complexity of interfacing and possible coupling paths for HEMP energy will greatly affect the choice of topological approaches to HEMP hardening.

e. Design verifiability.

EP 1110-R-2
31 Dec 90

(1) Hardness validation. A key issue in HEMP hardening philosophy and associated design concepts is that of hardness validation and required confidence levels for final acceptance. (Required confidence levels are usually specified only qualitatively.) Generally, the more critical the facility is to national military security, the more politically and publicly visible it will be; for these facilities, higher confidence levels will be required. In all cases, design concepts may not be chosen if they cannot be validated with acceptable confidence levels. For example, a design concept for a large underground facility that depends on a degree of protection from the overburden and has numerous conducting penetrations through the overburden may have hardness uncertainties. Examples include questions about the homogeneity of the overburden and difficulties in protecting penetrations when no highly conductive shield is present. If the facility is too large to be practically subjected to a threat level test by an EMP simulator and no other proven validation tests exist, the uncertainties will prevail and hardness confidence will be low.

(2) Retrofit designs. In retrofit designs, another consideration in concept selection may be the ability to validate hardness without disrupting the operation of critical systems. Concepts should be chosen to allow nondisruptive validation and acceptance testing.

(3) Designing to facilitate testing. Good design validation requires a choice of design concepts that facilitate testing. HEMP hardening management must include adequate funding and scheduling for this effort. The difficulty and cost of validation will increase with--

- (a) System complexity.
- (b) Topology layer and zone numbers.
- (c) The number of required penetrations.
- (d) The protective design philosophy.

(4) Approaches to validation. In considering the validation problem for concept selection, it is helpful to review the many approaches to validation, including laboratory testing, full-scale HEMP threat level field testing, partial scale threat-level field testing, current injection testing, scale model testing, physical modeling testing, computer modeling evaluations, analyses, and radio frequency CW shielding tests.

f. Physical environment. Various aspects of the facility physical environment can greatly affect concept selection, mainly in the degree to which corrosion can accelerate aging and degradation of protection.

g. Other factors. Other factors to be considered in concept selection are--

EP 1110-3-2
31 Dec 90

- (1) Complexity of required interactions with facilities.
- (2) Design and construction costs.
- (3) Constructibility.
- (4) Maintenance costs.
- (5) Reliability requirements.
- (6) Flexibility for expansion or system changes.
- (7) New construction versus retrofit.
- (8) Supportability.

3-3. Description of HEMP hardening concepts.

a. Shielding. For HEMP-hardened facilities, some kind of EM shielding is essential. Shielding theory is discussed in detail in chapter 5 and is treated thoroughly in the literature. Shielding involves the use of a barrier or series of barriers to reduce the magnitude of the EM energy incident upon the electronic or electrical system to be protected. Shielding philosophy can be developed around different approaches as discussed in paragraphs (1) through (6) below and shown in figure 3-1.

(1) Global shielding. Global shielding (or hardening) is a protection concept that uses an overall shield to encompass the entire facility. In this approach, all conducting penetrations and all apertures are protected at the shield. The intent is to keep all HEMP fields and HEMP-induced transients outside the protected volume. The global shield could be placed on the entire outer walls, ceiling, and floor (surface) of the facility, or it could be reduced to a smaller volume that contains all sensitive equipment to be protected. The most common shield material for global shielding of ground-based facilities is sheet steel with welded seams, although other designs can provide adequate global HEMP shielding.

(a) Global shielding may be desirable if there is a requirement to be able to modify, reorganize, add to, or move the sensitive equipment without changing the shield or protective features.

(b) A remote, yet possible, disadvantage of global shielding that must be considered is that a single protective component or device failure may jeopardize the entire facility.

(2) Tailored shielding. Tailored shielding is a protection concept in which shielding is designed and constructed according to specific protection requirements for the equipment involved. After defining the system to be protected, its possible operating configurations, the expected HEMP

environment, coupling paths, equipment sensitivities, and subsystem/system criticalities, the required protection levels for various subsystems or groups of subsystems can be defined. Tradeoff studies may be performed for comparing various shielding arrangements to verify that they meet safety margins in protection, cost-effectiveness, maintainability, survivability, flexibility, and other requirements. The objective is to optimize protection for the specific mission-critical system. Tailored shielding options may include global shielding, zonal shielding (discussed under (3) below), shielding of cabinets or components, or combinations thereof. In a typical tailored protection design, discrete protection will be provided to eliminate specific, localized deficiencies.

(3) Zonal or topological shielding. Zonal or topological shielding (ref 3-1) is a concept in which a facility is divided into zones, with shielding barriers located topologically in a shield within a shield configuration. Figure 3-2 shows a generic topological shielding system. The outer zone is designated zone 0; zone 1 is inside shield 1 but outside shield 2. Zones and shields are assigned increasingly larger numbers as they progress toward the more deeply nested areas.

(a) Note that figure 3-2 is a simple schematic to represent the zoning concept; although not depicted, each zone could contain more sets of subzones. For example, shield 3 could contain 2 or more zones designated as zone 4. Further, figure 3-2 shows possible shield types including a site housing shield and an interior shielded room, with equipment and component housings making up the shields of the next topological orders.

(b) The zonal concept shown in figure 3-3 is a specific example of an underground facility that uses topologically zoned protection. The rock and soil overburden above the facility serves as shield 1. Zone 1 is the volume between the underground building and the excavated outline of overhead rock. In some cases, a shield of this type provides adequate protection for robust electrical or electronic equipment. Shield 2 is composed of a sheet metal building that may provide only a limited level of shielding. Inside this building (zone 2), some systems would be adequately protected. The above-ground building and connecting conduit represent an extension of zone 2. Shield 3 is then the interior shielded room which provides further protection within zone 3, where sensitive, electronic equipment may be operated.

(c) Figure 3-4 shows another specific example of a zonal or topographically shielded facility for which steel-reinforced concrete comprises shield 1. This type of shield usually does not provide adequate protection and thus the additional shields are necessary.

(4) System configuration. The term "system configuration" identifies which way the cables, wires, equipment, and subsystems are laid out in relationship to each other, as well as the relationship of these items to the topological boundaries. In some instances, the cables, connectors, and equipment casings are actually part of the topological protection. Although

EP 1110-3-2

31 Dec 90

"system configuration" as defined does not directly attenuate the environment, it is an important element in the topological protection concept. The system configuration influences protection design requirements since some configurations are easier to protect than others (e.g., collocation of all mission-critical equipment). Thus, the system configuration should be coordinated with the protection design and the protection topology will be optimal for a specific configuration. During the facility life cycle, the protection design may be required to accommodate some changes in configuration. To ensure that the configuration's design modifications do not compromise or defeat the protection, careful configuration management is necessary. The topology should be designed to tolerate configuration changes that are totally within a boundary. The boundary can never be violated (for example, opened)--only extended. All modifications must be subjected to review by EMP experts to ensure continual compliance with the HEMP hardening requirements.

(5) Cable shielding. Conductive or metallic cable shielding or conduit is used in the zonal/topological protection concept to extend the boundary formed by equipment enclosures and thus provide a way to interconnect elements while maintaining boundary continuity. Cable shielding is also used to protect a wire or wires as they travel from one boundary to another. This would be the case with a shielded RF signal traveling from its entrance into a building to the RF receiver. From a HEMP standpoint, the shielding attenuates coupling of radiated energy within the first boundary as the signal travels to the receiver. Of course the shield is somewhat reciprocal in that it also prevents signals from radiating out of the cable. The main feature of cable shielding stressed here is continuity of the boundary provided by the cable shield/connector combination which may require special joints.

(a) Another way to maintain this continuity and provide cable shielding is by using steel conduit to house all wires and cables. The steel conduit will provide substantially higher shielding levels than the cable shields. Chapter 5 presents conduit system design in detail.

(b) Both cable shields and conduit connected to a shielded zone must have equal or greater shielding effectiveness than the shield.

(c) Figure 3-5 shows a cable entry vault used to protect cable penetrations through a shield. Entry vaults are discussed under shield penetrations in paragraph c below.

(6) Grounding. Some form of grounding is required in any electrical or electronic system for protecting personnel from electrical shock, controlling interference, proper shunting of transient currents around sensitive electronics, and other reasons. (Grounding does not directly provide protection against EMP, but must be done properly to prevent creation of more serious EMP vulnerabilities.) Ideally, grounding would keep all system components at a common potential. In practice, because of possible inductive loops, capacitive coupling, line and bonding impedances, antenna ringing

EP 1110-3-2
31 Dec 90

effects, and other phenomena, large potentials may exist on grounding circuits. The choice of grounding concept is therefore important in the HEMP protection philosophy.

b. Hardening allocation concept. The shielding concepts in this chapter introduce the concept of hardening allocation in which the overall protection philosophy specifies degrees of hardening for each zone. The practicality of this concept usually depends on the complexity of the system to be protected. If it is determined that an overall SE of 80 decibels is required for the most sensitive components, but the remaining elements require only 60 decibels, then zones with different SE may be established. The cost-effectiveness of a zonal design with a hardening allocation for each barrier must be studied carefully on a facility/ system specific basis to determine the practicality of this approach.

c. Shield penetration protection concepts. All shielded zones will require penetrations to allow entry of equipment, personnel, electric power, communications, and control signals, ventilation, water, fuel, and various fluids. Without protection, these penetrations compromise the shield.

(1) Large access doors. Large access doors are often necessary to provide an entry for equipment, supplies, or vehicles into EMP hardened facilities. In facilities that require blast overpressure protection, large blast doors are used. These doors generally use one or more thick steel plates to provide protection. The door's inherent shielding ability is thus high, but its large size presents a difficult gasketing problem. If blast protection is not required, it is still necessary to design the door with a high degree of structural strength. This step is to ensure that the door can provide the necessary gasket compression force and that proper mechanical alignment of closure contact surfaces is maintained.

(2) Personnel entrances. Two concepts are commonly used for personnel entrances: conventional EMP/RFI shielded doors and personnel tunnels that act as waveguides below cutoff. The shielded doors generally use metal fingerstock or EMI/RFI gaskets to provide an electromagnetic seal around the door jamb periphery. Currently available gasket and fingerstock doors require regularly scheduled maintenance and/or replacement to maintain required shielding levels. The gaskets are relatively easily damaged and also require replacement. Air-expandable doors may also be used, although they typically have more maintenance problems. These doors generally use a movable subassembly of two shielding plates on a framework that is moved on rollers in and out of a steel-framed opening. When closed, air expansion tubes cause the two shielding plates to make uniform surface contact with the frame inner surfaces.

(a) Fingerstock doors can provide over 80 decibels of shielding to magnetic fields from 100 kilohertz through 30 megahertz and greater SE to plane waves and electric fields. Air-expandable doors can provide greater than 120 decibels of magnetic field SE from 10 kilohertz to 10 gigahertz.

EP 1110-3-2
31 Dec 90

(b) Air-expandable doors require an air source and air controls with back-up in safety controls. They also require very strong steel frames and, as a result, are more expensive than gasketed doors. They are also more difficult and costly to maintain. The air-expandable door would thus be used only when a large safety margin of HEMP shielding is needed or when equipment to be protected is extremely sensitive to HEMP or other EM interference.

(c) The waveguide entry tunnel acts as a WBC that will typically have a cutoff frequency in the 60-megahertz region. Thus, the higher frequencies in the HEMP spectrum will penetrate it. Doors are therefore required to prevent the higher frequency signals from penetrating. Since only high frequencies can propagate through, doors have good attenuation in this range and can easily provide the required attenuation. Maintenance requirements are not as stringent as for doors that must block the entire frequency spectrum; thus, the waveguide entry tunnel for personnel access is attractive from a life-cycle cost standpoint. When the facility has a TEMPEST requirement as well as EMP shielding requirements, the tunnel is usually designed with interlocking doors, i.e., a door at each end and interlocked so that only one door can be opened at once, thus preventing any leakage of classified information during the entry of personnel. The waveguide entry tunnel also is highly useful in underground or buried facilities because the overburden attenuates the high frequencies, thus acting to complement the tunnel attenuation.

(3) Electrical penetrations. A common feature for electrical penetrations in a global protection approach is a cable entry vault to prevent large currents on external conductors from being conducted into the facility. Ideally, all penetrations should enter a single vault. In some cases, however, it may be necessary to separate the vault into two compartments or to use two vaults for penetrations by different types of lines: power, signal and control, and antenna. The vault must be connected directly to the external facility ground system. (See chapter 5 for details.) The cable entry vault serves three purposes: to insure that penetrating conductors do not cause conducted HEMP energy to enter the protected topology; to contain and divert penetrator-conducted HEMP energy to the boundary exterior; and to contain or divert radiant EM energy resulting from the activation of transient suppression devices subjected to a conducted pulse. Conductive penetrations, such as a conduit, waveguide, or shielded cable, must have a circumferential weld or other means of providing good electrical connection at the intersection with the entry vault.

* Cutoff frequency is determined by the relationship $F_0 = 5900 \text{ MHz/W}$, where W is the greatest cross sectional dimension in inches. Below cutoff, the waveguide attenuation is a function of the waveguide length. In practice, the length-to-width ratio should be 5.

(4) Transient suppression devices and filters. Transient suppression devices fill a critical gap in the concept of topological protection. The necessity of supplying power to a facility and of communicating over cables or antennas are two major factors contributing to their use. Power lines entering a facility are typically connected to an unshielded power grid so that large, conducted currents must be bled off to prevent their entry into a facility. These currents are diverted to the exterior boundary of the topology. This boundary can be an overall external shield or an enclosed entrance vault. Antennas, such as for high-frequency (HF) communications, are designed to gather EM signals (at wavelengths in the EMP frequency spectrum) and to apply these signals to the center conductor of a shielded cable. The EMP transients associated with an HF antenna can be, by far, the largest single signal entering a facility. Transient suppressors often are used in conjunction with filters. Filters are frequency-selective whereas surge suppressors are amplitude-selective. Filters often are used to attenuate transients associated with the nonlinear operation of surge arresters. They also are used for selectively passing (or stopping) frequency bands as in the case of antenna cable penetrations. Transient suppressors are an integral part of the EM topology, demanding specific installation techniques as will be seen later. A spark gap is a surge suppressor that provides a conducting path to ground when the voltage across the device exceeds the gap breakdown level. Spark gaps with a high current capacity do not operate quickly enough to block all HEMP energy transients entering the vault. For this reason, it may be necessary to use other protection devices in conjunction with the spark gap.

(5) Electromagnetic isolation. The electromagnetic isolation concept involves the use of elements either immune to interaction with EM radiation or that provide a current path interruption. Optical fibers are examples of elements immune to EM radiation that can be used to reduce the number of conductive penetrations. For practical purposes, optical fibers can be used for long communications links without signal interference from HEMP. Further, they can be used to enter shielded zones through waveguide below cutoff penetrations without compromising the EM shielding effectiveness, as figure 3-6 shows. Where possible, optical fibers are recommended for--

- (a) Voice and data communications lines.
- (b) Energy monitoring and control systems (EMCS).
- (c) Intrusion detection systems.
- (d) Other security systems.
- (e) Control systems.

*Within a facility, inside shield 1, power lines are often routed through steel conduits to provide shielding.

EP 1110-3-2
31 Dec 90

(f) Any other use where possible and practical.

(6) Dielectric isolation. Other isolation techniques include using dielectric isolators for shield penetration when external metallic EM energy collectors are involved. Examples are control rods or cables (normally metallic), piping systems for fluids, and metallic duct systems for air. Dielectric sections are installed at or near the shield to prevent the energy induced on the external metallic part from being conducted through the shield. Dielectric control rods can enter through a shield in the same way as optical fibers, that is, through a waveguide-below-cutoff section. Dielectric isolation concepts for metallic piping systems and air ducts are discussed in chapter 5.

(7) Isolation switching. Although not recommended now, isolation switching has been provided at facilities so they can use commercial electric power during routine operation, but can switch to internal generators or power systems in the event of an emergency such as nuclear attack. Since the commercial power wiring is a source of significant HEMP energy injection through a shield, switching to internally generated power is an obvious advantage when advance warning of impending nuclear attack is received and throughout the entire nuclear attack cycle. This concept applies to communications lines and control lines as well as power lines. Switching used in past facility designs has been called "alert attack" switching. Such switching must provide adequate switch contact separation to prevent arcing, and must be designed to reduce coupling interactions between wiring and switch contacts to acceptable levels. It should be noted that advance notice of a HEMP attack is not always provided.

3-4. Cited reference.

- 3-1. Vance, E. F., Shielding and Grounding Topology for Interference Control, Interaction Note 306 (Air Force Weapons Laboratory [AFWL], April 1977).

3-5. Uncited references.

Bailey, D. T., et al., EMP Hardening Guidelines: System Life Cycle Cost Design Considerations, AWFL-TR-79-161 (AWFL, May 1980).

BDM Corporation, Defense Nuclear Agency (DNA) EMP Course (Draft), BDM/W-82-305-TR (DNA, April 1983).

Mindel, I. N., DNA EMP Awareness Course Notes, Third Edition, DNA 2772T (October 1977).

* Rods that must be mechanically rotated or pulled to control switches, valves, and other components.

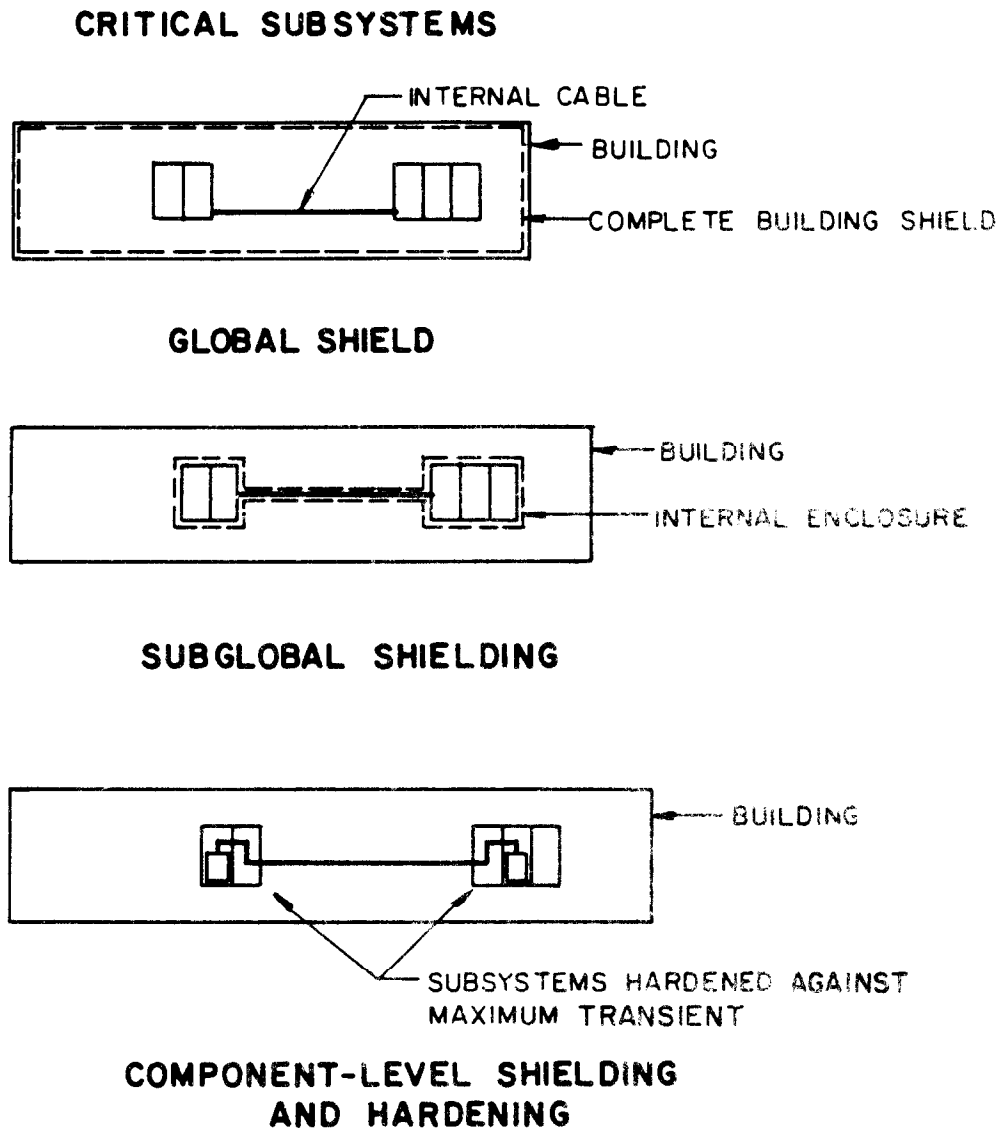


Figure 3-1. Building examples showing three concepts for critical equipment protection.

EP 1110-3-2
31 Dec 90

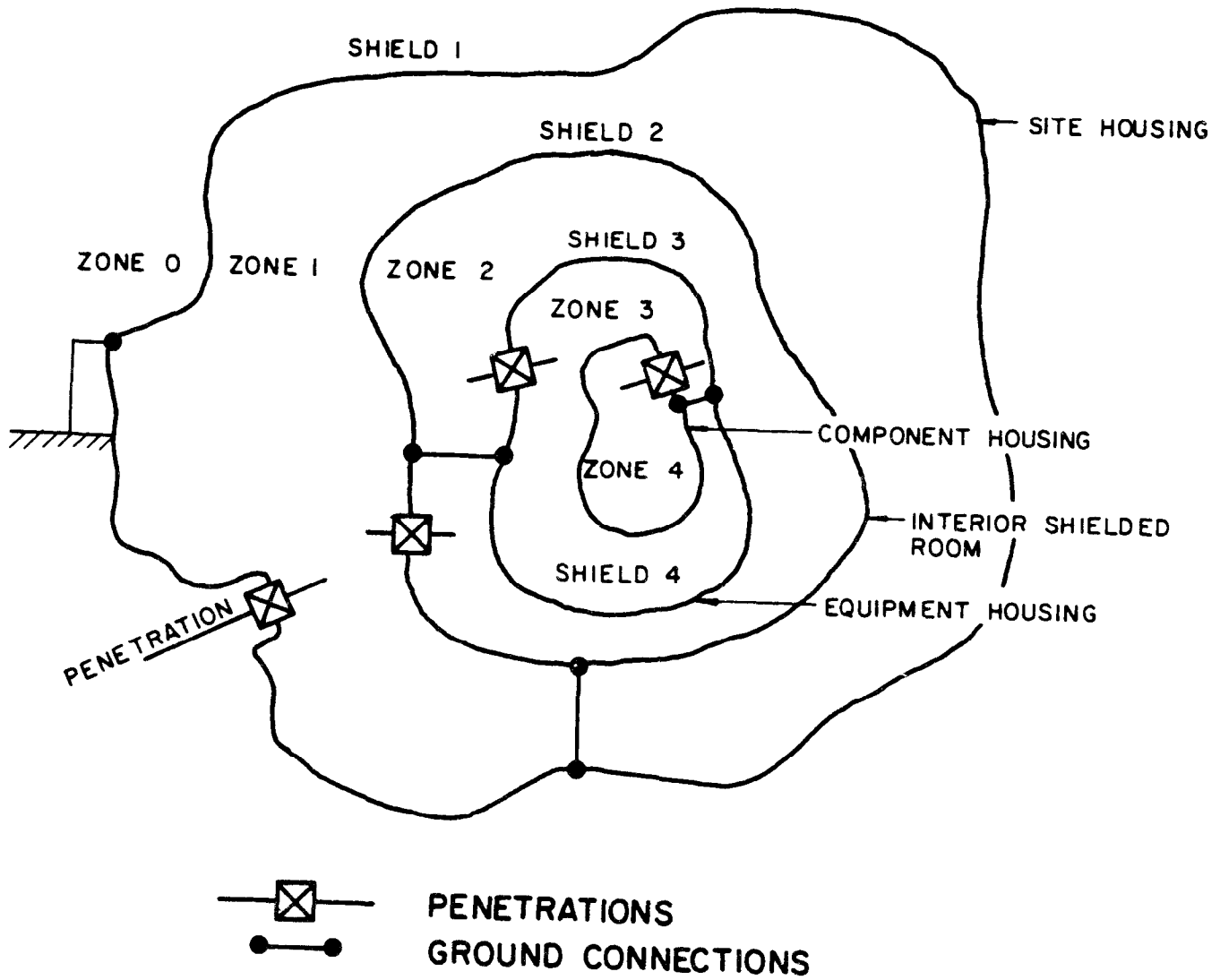


Figure 3-2. Zonal shielding concept.

EP 1110-3-2
31 Dec 90

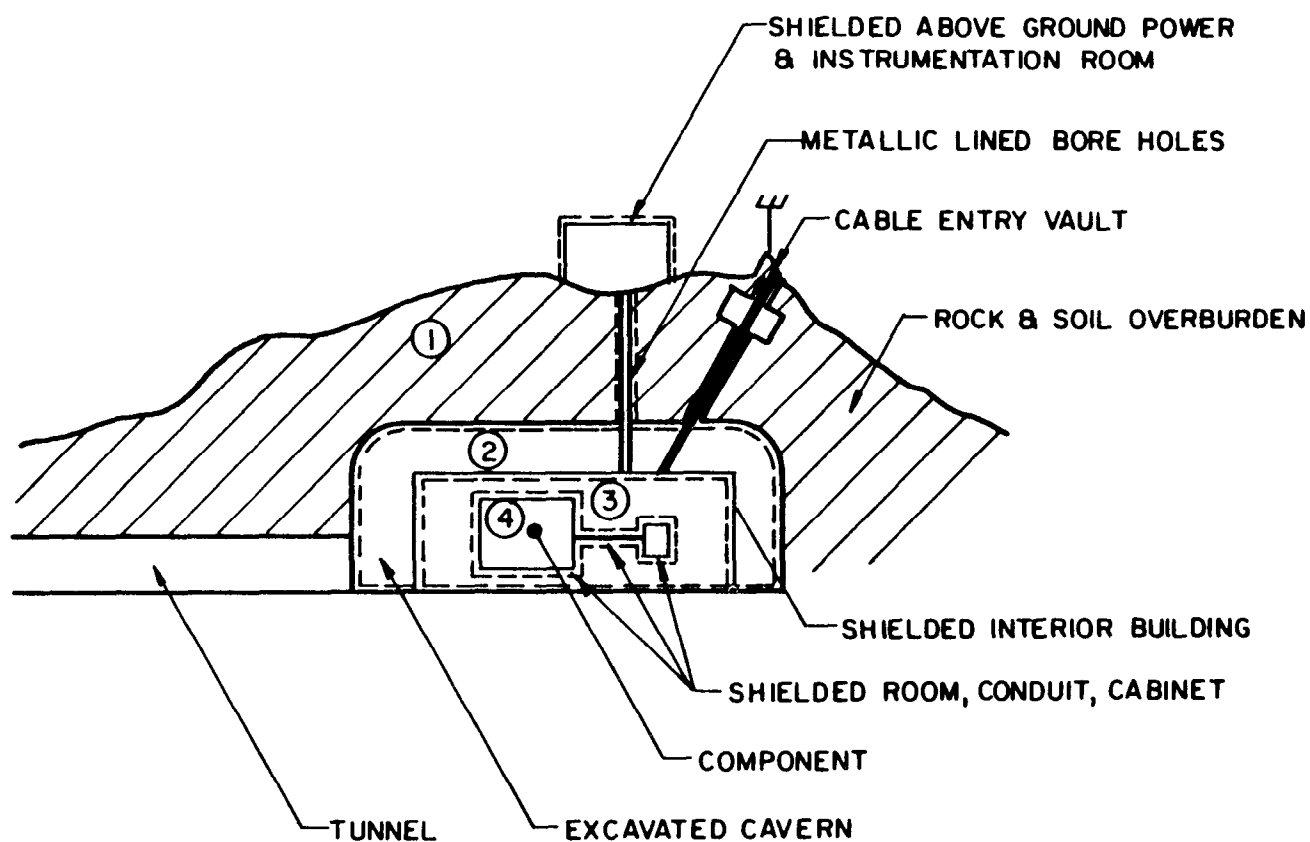


Figure 3-3. Underground facility with four zones.

EP 1110-3-2
31 Dec 90

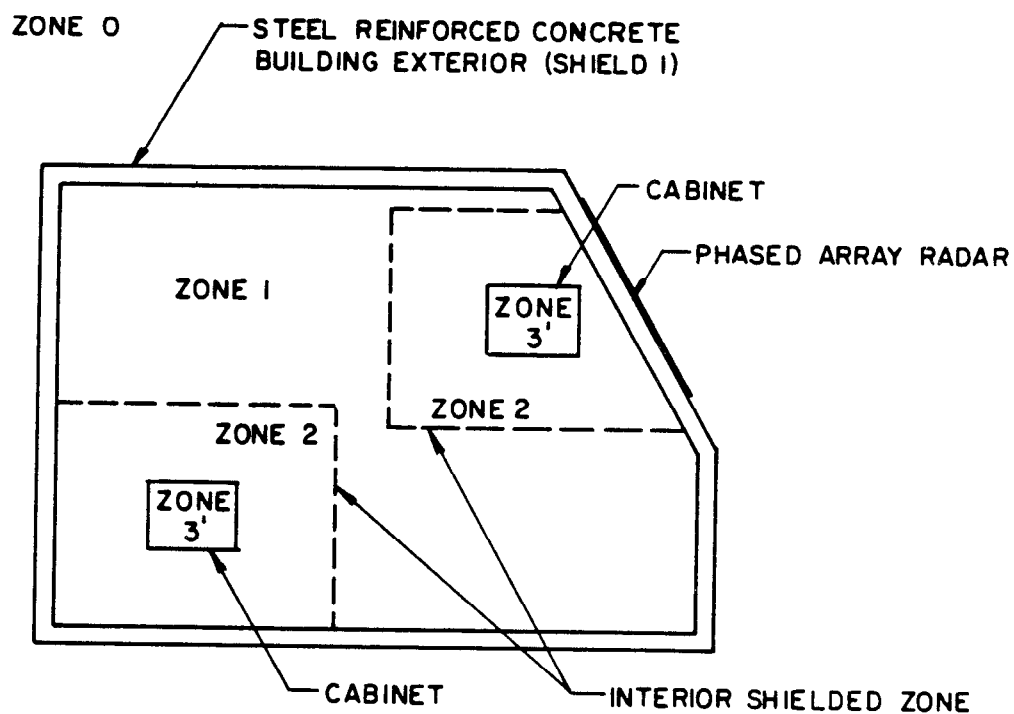


Figure 3-4. Zonal shielding concept with steel-reinforced concrete as shield 1.

EP 1110-3-2
31 Dec 90

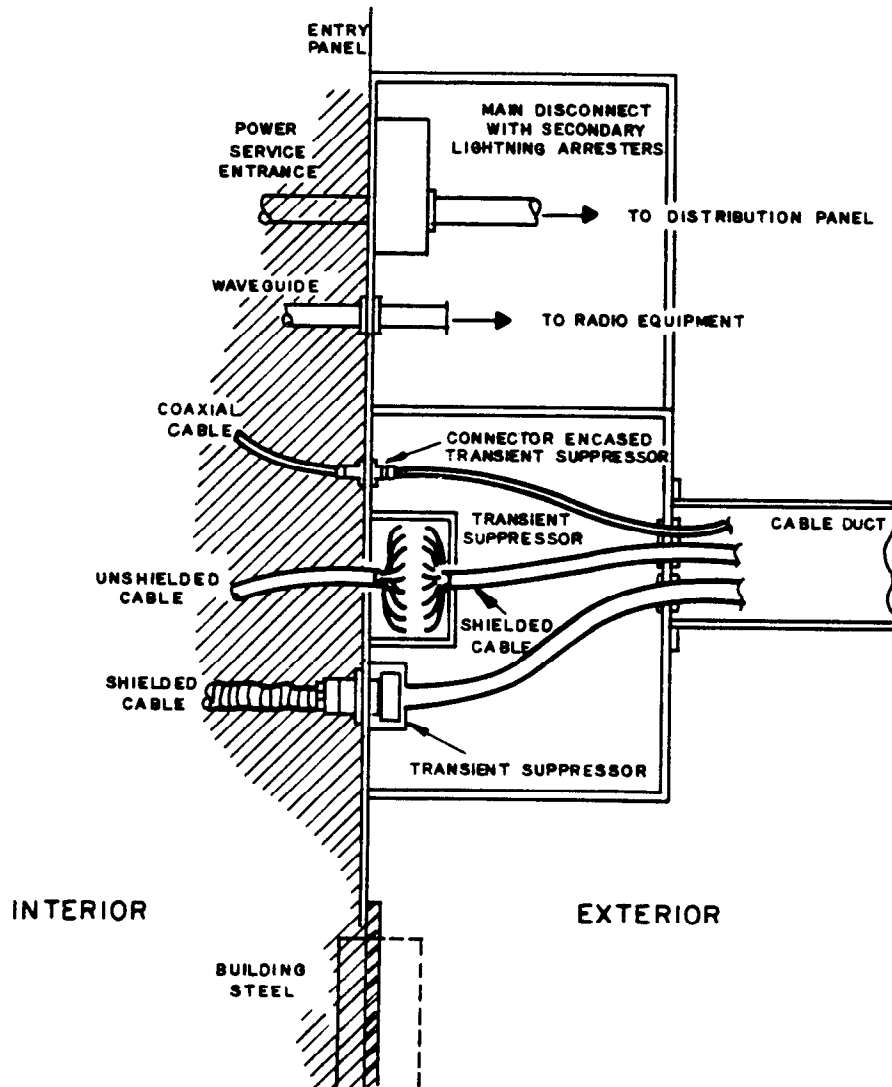


Figure 3-5. Shielded enclosure: cable entry vault.

EP 1110-3-2
31 Dec 90

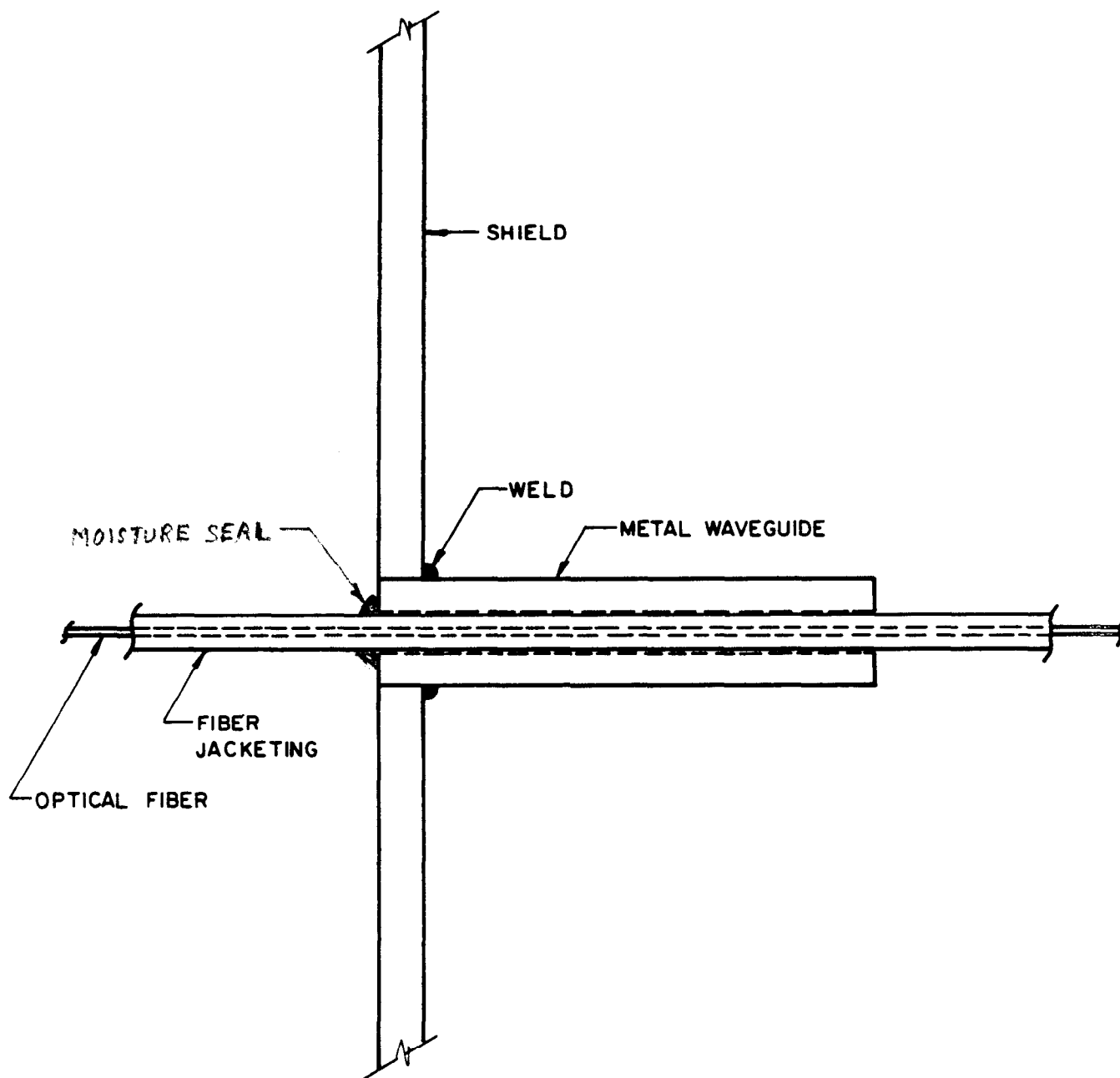


Figure 3-6. Optical fiber shield penetration.

CHAPTER 4

SYSTEM ENGINEERING REQUIREMENTS

4-1. Outline. This chapter is organized as follows:

- 4-1. *Outline*
- 4-2. *Standards and specifications*
- 4-3. *Electromagnetic integration*
 - a. *Incompatible design approaches*
 - b. *Correcting incompatibilities*
 - c. *Electromagnetic shielding*
 - d. *Surge protection*
- 4-4. *HEMP and lightning protection integration*
 - a. *Lightning rise time*
 - b. *Frequency and current levels*
 - c. *Induced transients and injected current*
 - d. *Voltage surges*
 - e. *Radiated and static fields*
 - f. *Magnetic fields*
 - g. *Summary*
- 4-5. *HEMP/TEMPEST and electromagnetic integration*
 - a. *Electromagnetic compatibility (EMC)*
 - b. *Electromagnetic interference (EMI)*
 - (1) *Natural radio noise*
 - (2) *Purposely generated signals*
 - (3) *Man-made noise*
 - c. *Achieving electromagnetic compatibility*
 - (1) *Frequency ranges*
 - (2) *Spectra encompassed*
 - (3) *Interference within enclosures*
 - (4) *Exceptions*
- 4-6. *Environmental requirements*
 - a. *Corrosion*
 - b. *Groundwater*
 - c. *Thermal effects*
 - d. *Vibration and acoustics*
 - e. *Ground shock*
- 4-7. *Cited references*

4-2. Standards and specifications. Definitive standards and specifications for hardening facilities against HEMP/TEMPEST do not exist. However, efforts are underway to develop them and to integrate them with other HEMP/TEMPEST requirements and with electromagnetic compatibility (EM) standards. Results of some recent studies have been reported (refs 4-1 through 4-3). Campi et al. (ref 4-1) compiled a listing of Government and industrial standards, specifications, and handbooks related to HEMP/TEMPEST mitigation. Most of these standards pertain to EMC and TEMPEST (table 4-1). However, many of

EP 1110-3-2
31 Dec 90

these specifications and standards may be useful in integrating EMP hardening requirements. A comprehensive listing of EMP-related standards is available in reference 4-4.

4-3. Electromagnetic integration. Facilities often are required to be protected against several EM environments, including HEMP (or other EMP), electromagnetic interference (EMI), electromagnetic compatibility, and lightning. The facility may also have TEMPEST requirements that impose the need for communications security through control of compromising EM emanations.

a. Incompatible design approaches. Vance et al. (ref 4-2) have examined 70 related standards and specifications and tabulated areas in which the design approaches are not compatible for all EM protection requirements. Many of these incompatibilities are related to methods for grounding cable shields and allowances for penetrating conductors.

b. Correcting incompatibilities. Graf et al. (ref 4-3) have recommended ways to correct these incompatibilities. In view of these studies and other programs, unified EM specifications and standards probably will eventually become available. Meanwhile, designers will find it necessary to integrate the EM design on a site-, facility-, and system-specific basis.

c. Electromagnetic shielding. Generally, the main method used in EM protection is EM shielding. The shielding required for HEMP/TEMPEST is usually more than enough for all other EM protection. A comprehensive discussion of grounding and bonding technology for all EM protection is in MIL-HDBK-419A (ref 4-5). MIL-STD-188-124A gives specific grounding and bonding requirements (ref 4-6).

d. Surge protection. An area in which care must be taken to ensure compatibility in EM integration is surge protection. Some surge arresters used for lightning do not clamp fast enough to protect against EMP. Some ESAs used for EMP may not have great enough current carrying capacity for lightning protection in all situations. Thus, for compatible lightning and EMP protection, a carefully selected combination of protection elements will be required.

4-4. HEMP and lightning protection integration. The EM environment generated by lightning differs from that of HEMP in energy spectral distribution rise time, current levels, pulse repetition and coverage area.

a. Lightning rise time. Many early studies indicated that the typical rise time of lightning was almost three orders of magnitude slower than that of HEMP. More recent work, however, has shown that radiation fields produced by lightning can have much faster rise times. Step leaders in the initial stroke have had measured rise times reportedly approaching 30 nanoseconds. Return strokes have been determined to have initial portions with rise time in the 40- to 200-nanosecond range. A complete lightning flash contains a first

EP 1110-3-2
31 Dec 90

stroke with a downward-moving step leader and usually numerous return strokes as shown in figure 4-1. The total flash time can be greater than 1 second.

b. Frequency and current levels. A comparison of lightning and HEMP in the frequency domain shows that radiated lightning energy is higher at low frequencies and lower at high frequencies as indicated in figure 4-2. The current levels of lightning return strokes average nearly 35 kiloamps, but may be less than 10 kiloamps and as high as several hundred kiloamps for so-called "superbolts."

c. Induced transients and injected current. Hazards common with both HEMP and lightning are induced transients coupled onto sensitive elements and injected current from exterior electrical conductors. Lightning also can strike directly with extreme damage potential. In rare cases, the direct strike has been known to cause structural damage as well as electrical damage, even to underground facilities. Thus, facilities need a system of lightning rods with suitable grounding to divert the extremely high currents (up to hundreds of kiloamperes peak) away.

d. Voltage surges. Lightning can produce high voltage surges on power lines without a direct strike. Figure 4-3 shows some typical surge values versus distance from the stroke.

e. Radiated and static fields. One study has identified radiated fields associated with lightning (ref 4-7). Figure 4-4 summarizes approximated typical near-field radiated E-field values. Another study has identified radiated and static fields associated with lightning (ref 4-8). Figure 4-5 shows averages for these fields.

f. Magnetic fields. Table 4-2 lists typical values of the H-field close to a stroke. The close in H-field from lightning thus has higher magnitude than the HEMP H-field (see table 4-2 for magnitudes); since it has greater energy content at low frequencies, shield thickness must be greater than for HEMP.

g. Summary. In summary, integrating HEMP and lightning protection requires--

(1) Greater shield thickness for lightning if protection from close-in strokes is required since the H-field magnitude can be greater, although this is not common practice.

(2) More robust surge arresters for lightning.

(3) Use of lightning rods.

(4) High-frequency protection for HEMP using more sophisticated transient protection and filtering.

EP 1110-3-2
31 Dec 90

4-5. HEMP/TEMPEST and electromagnetic integration. EMC is defined in ref 4-9 as the ability of communications-electronics equipments, subsystems, and systems to operate in their intended environments without suffering or causing unacceptable degradation because of unintentional EM radiation or response. Electromagnetic interference (EMI) results when EM energy causes unacceptable or undesirable responses, malfunctions, degrades or interrupts the intended operation of electronic equipment, subsystems, or systems. RFI is a special case of EMI for which the radio frequency transmission (usually narrow-band) causes unintentional problems in equipment operation. For commercial electronic and electrical equipment, systems, or subsystems, the Federal Communications Commission (FCC) has regulations defining allowable emission and susceptibility levels. Military equipment is regulated by MIL STD 461 and MIL STD 462 (refs 4-10 and 4-11). MIL STD 461 defines allowable emission levels, both conducted and radiated, and allowable susceptibilities, also both conducted and radiated. Other specifications exist, but they apply to specific equipment.

a. Electromagnetic compatibility (EMC). EMC requirements usually apply to individual equipment as well as to the overall system. Because of equipment level requirements, the equipment cabinets or racks often must have a degree of protection, which comprises part of the topological protection.

b. Electromagnetic interference (EMI). The EMI environment has contributors from three main classes:

(1) Natural radio noise. Natural radio noise originating mainly from atmospheric disturbances (including lightning) and partly from extraterrestrial sources.

(2) Purposely generated signals. Signals that are generated purposely to convey information but that may interfere with the operation of other equipment.

(3) Man-made noise. Man-made noise such as spectral components generated incidentally by various electrical and electronic devices, motors, generators, and other machinery.

c. Achieving electromagnetic compatibility. Achieving EMC involves the same principles as protection against HEMP/TEMPEST. Generally, a HEMP/TEMPEST-protected facility will provide EMC protection as well over most of the desired frequency range. Some exceptions are--

(1) Frequency ranges. EMC encompasses the low frequencies, including the power frequency spectrum (5 to 400 hertz), and therefore, may have shielding and filtering requirements different than those for HEMP or TEMPEST protection.

(2) Spectra encompassed. EMC includes the VHF and microwave spectra as well as system-specific radiators or susceptibilities requiring special

EP 1111-3-7
31 Dec 90

treatment. Examples are susceptibilities to high power radars beyond the HEMP/TEMPEST frequency range and switching transients below the HEMP/TEMPEST frequency range.

(3) Interference within enclosures. EMC also can include interference between equipment within the same shielded enclosures.

d. Exceptions. Clearly, EMC integration requires that special engineering attention be given to these stated exceptions. For further guidance, see references 4-9 and 4-12.

4-6. Environmental requirements. HEMP/TEMPEST protection must withstand adverse environmental conditions that may occur at the facility. The major concern is corrosion of buried grounding or shielding system elements, including exterior steel sheets and buried water pipe or conduit. Other environments of concern include those with high temperatures, excessive vibration, and potential ground shock.

a. Corrosion. Design details and the materials used for external grounding systems and underground shielding elements will affect the corrosion of all exterior exposed metal installed underground throughout the facility complex. Galvanic cells are the main cause of corrosion associated with grounding system and adjacent underground metal objects. A galvanic cell is produced when two dissimilar metals are immersed in an electrolyte and the potential difference between electrodes causes a current to flow in a low-resistance path between them. For HEMP/TEMPEST-protected facilities, the many grounding connections between steel objects, including shielding and reinforcing bars in contact with the shield, and the external grounding system provide a low-resistance conductive path between interconnected metals in the soil. Current will flow from cathodic material, such as copper or concrete-encased steel, through these connections to bare steel, such as pipes and conduits (anodic material). The current flow carries ferrous ions into the earth electrolyte, resulting in galvanic corrosion of the pipes and conduits. Conventional design practice for corrosion protection is to electrically isolate the ferrous metal to be protected from buried copper and concrete embedded steel. The protected metal often is coated with a dielectric material. Conventional procedures must be modified to meet the restrictions and limitations imposed by HEMP/TEMPEST requirements for electrically continuous and grounded pipes, conduit, and electrical equipment. Close coordination is required between grounding system design and that for corrosion protection. Through such coordination, it is often possible to design grounding systems that avoid corrosion problems, reduce corrosion protective requirements, and simultaneously improve the grounding system.

b. Groundwater. In areas with high water tables, groundwater presents a threat to underground shielding elements. Careful design is required to obtain water-tight penetrations of the floor, roof, and exterior walls. This includes piping, conduit, and utility or access tunnel connections.

EP 1110 3-2
 31 Dec 70

c. Thermal effects. If the metallic shield is subjected to temperatures somewhat higher than adjacent concrete, the sheets will tend to buckle outward. This condition could occur during construction or during building operation. Shield buckling is undesirable because welds can be damaged, compromising the shield and possibly the steel envelope's structural integrity. To eliminate buckling, provisions for expansion, temperature control, and/or securing the plates must be included in shielding design.

d. Vibration and acoustics. Shielded rooms in which the audible noise level is high should be studied for possible acoustical treatment because of steel's low sound absorption. Likewise, shielded rooms that have vibrating equipment should be given special consideration to avoid resonant vibration of shield panels or shielding elements. Excessive panel vibration could eventually damage welded seams, thus compromising the shielding.

e. Ground shock. If the hardened facility will be in an area of high seismic activity, or if it must withstand nuclear strikes with high overpressures, requirements will be defined for ground shock resistance. Expansion joints may be required between linear plate shielded structures to protect against differential motion from ground shock. Design for ground shock protection should be delegated to structural engineers who have appropriate experience and expertise.

4-7. Cited references.

- 4-1. Campi, M., G. L. Roffman, and J. R. Miletta, Standardization for Mitigation of High Altitude Electromagnetic Pulse (HEMP), HDL-TM-80-33 (U.S. Army Electronics Research and Development Command, Harry Diamond Laboratories, December 1980).
- 4-2. Vance, E. F., W. Graf, and J. E. Nanevich, Unification of Electromagnetic Specifications and Standards Part I --Evaluation of Existing Practices, SRI International AFWL Interaction Note 420 Defense Nuclear Agency [DNA], July 1981).
- 4-3. Graf, W., J. M. Hamm, and E. F. Vance, Nitrification of Electromagnetic Specifications and Standard Part II: Recommendations for Revisions of Existing Practices, DNA 5433F-2 (DNA, February 1983).
- 4-4. Schulz, R. B., EMC Standards Manual, ECAC-HDBK-82-043 (U.S. Department of Defense [DOD], November 1982).
- 4-5. MIL-HDBK-419A, Grounding, Bonding, and Shielding for Electronic Equipments and Facilities (DOD, 21 January 1982).
- 4-6. MIL-STD-188-124A, Grounding, Bonding, and Shielding (DOD, 2 February 1984).

EP 1110-3-2
31 Dec 90

- 4-7. Uman, M. A., M. J. Master, and E. P. Krider, "A Comparison of Lightning Electromagnetic Fields With Nuclear Electromagnetic Pulse in the Frequency Range 10^4 - 10^7 Hz," IEEE Transactions on Electromagnetic Compatibility, EMC-24 (4) (Institute of Electrical and Electronic Engineers [IEEE], November 1982).
- 4-8. Cianos, N., and E. T. Pierce, A Ground-Lightning Environment for Engineering Usage, Technical Report 1 (Stanford Research Institute, August 1972).
- 4-9. Engineering Design Handbook, Electromagnetic Compatibility, DARCOM Pamphlet P 706-410 (U.S. Army Materiel Command [AMC], March 1977).
- 4-10. MIL-STD-461B, Electromagnetic Emission and Susceptibility Requirements for the Control of Electromagnetic Interference (DOD, 1 April 1980).
- 4-11. MIL-STD-462, (U) Measurement of Electromagnetic Interference Characteristics (DOD, 9 February 1971). (C)
- 4-12. USAF Design Handbook DH-1.
- 4-13. NACSEM 5204, (U) Shielded Enclosures (National Security Agency, May 1978). (C)
- 4-14. NACSEM 5203, (U) Guidelines for Facility Design and Red/Black Installation, (National Security Agency, June 1982). (C)
- 4-15. MIL-HDBK-232A, (U) Red/Black Engineering Installation Guidelines (Draft). (C)

EP 1110-3-2
31 Dec 90

Table 4-1. HEMP/TEMPEST-related standards and specifications. (Sheet 1 of 3)

Specifications and Standards	Issuer	Superseded by	Short title.
AFSC DM 1-4	USAF	-	Electromagnetic Compact
AFSC DH2-7	USAF	-	Sys Survivability
AFSCM 500-6	USAF	-	EMP Ef on Air Force
AIR-STD-20/16	USAF	-	Des Gde Haz of EMR-Argon Wpn Sys
AIR 1221	SAE	-	EMC Sys Des Require
AIR 1255	SAE	-	Spect An for EMI Mgmt
AIR 1173	SAE	-	Test Proc-Mar RF Shldng Char
AIR 1404	SAE	-	DC Resis vs. RF IMP-EMI Gask
AIR 1500	SAE	-	Bib Lossy Filters
AN-J-1	USN/USAF	MS 2508	Bonding Jumpers
ANS C63.2	ANSI	IF	RI-FI Meters < 30 MHz
ANS C63.3	ANSI	IF	Msrmts, < 25 MHz
ANS C63.5	ANSI	IP	Msrmt 20 MHz-1 GHz
ANS C63.8	ANSI	IP	Msrmt < 30 MHz
ANS C63.9	ANSI	IP	RI-FI Meters 0.01-15 kHz
ARP 935	SAE	-	Sugg EMI Cntl Plan Outline
ARP 936	SAE	-	EMI 10-microF Capacitor
ARP 958	SAE	IF	Antenna Factors
ARP 1172	SAE	-	Filt. Conv EMI Gen Spec
DCA-330-190-1	DCA	-	Equip Performance
DCAC-330-175-2	DCA	-	DCS Engr Installation
DIAM-50-3A	DIA	-	Phy Security Stds for Sensitive Compartmented Information Facilities
DNA 2114H-1	DNA	-	EMP Hdbk, Des Principles
DNA 2114H-2	DNA	-	EMP Hdbk, Anal & Treating
DNA 2114H-3	DNA	-	EMP Hdbk, Env & Applications
DNA 2114H-4	DNA	-	EMP Hdbk, Resources
DNA 3286-H	DNA	-	EMP Preferred Test Proc.
D65/9371	BSI	-	RFI Aircraft Require
FED-STD-222	All Feds	NACSEM-5100	Info Process Emissions
FED-STD-1030A	DCA/NCS	Proposed	Balanced Dig. Interface Ckts
FED-STD-1030A	DCA/NCS	Proposed	Unbalanced Dig Interface Ckts
FED-STD-1040	DCA/NCS	Proposed	Data Term, Data Ckt Interface
JAN-I-225	USA/USN	MIL-I-6181	Interfer Cntl/Test
J551	SAE	J551A	Vehicle RFI
J551A	SAE	IF	Vehicle RFI
MIL-B-5087B (ASG)	USN/USAF	Amend #2	Aerospace Bonding
MIL-C-11693A	USANAR	MIL-C-11693B	R-I Feedthru Capacitor
MIL-C-11693B	USANAF	IF	R-I Feedthru Capacitor
MIL-C-12889	USA SC	MIL-C-12889A	R-I Bypass Capacitors

Table 4-1. HEMP/TEMPEST-related standards and specifications. (Sheet 2 of 3)

Specifications and Standards	Issuer	Superseded by	Short title
MIL-C-12899A	USANAF	IF	R-I Bypass Capacitors
MIL-C-19080	USAN SHIPS	MIL-C-11693B	R-9 Bypass Capacitors
MIL-C-39011	USANAF	IF	Feedthru Capacitors
MIL-E-4957A	USAF	MIL-E-4957A(ASG)	EMI Shielded Enclosure
MIL-E-4957(ASG)	USN/USAF	Cancelled	EMI Shielded Enclosure
MIL-E-55301(EL)	USA	MIL-STD-461/462	EM Compatibility
MIL-E-6051C	USANAF	MIL-E-6051D	Sys EMC Require
MIL-E-6051D	USANAF	IF	Sys EMC Require
MIL-E-8669	USN BuA	MIL-E-4957A(ASG)	EM Shielded Enclosure
MIL-E-8881	USANAF	IF	Shielded EnclosureMIL-F-
15733C	USANAF	NIL-F-15733D	Radio Interf Filters
MIL-F-15733D	USANAF	NIL-F-15733E	Radio Interf Filters
MIL-F-15733G	USANAF	IF	Radio Interf Filters
MIL-F-18327C	USANAF	-	Filter Specs
MIL-F-18344A	USN	MIL-F-15733C	Radio Interf Filters
MIL-HDBK-232A	USANAF	-	RED/BLACK Engr Instal Gdlines
MIL-HDBK-411	USANAF	-	Long Haul Comm & Env Cntl
MIL-HDBK-419A	USANAF	IP	GBS for Telecomm Facilities
MIL-I-6051	USANAF	MIL-I-6051C	Aircraft EMI Limits
MIL-I-6051A	USAF	MIL-E-006051B	Aircraft EMI Limits
MIL-I-006051B	USAF	MIL-E-6051C	Sys EMC Require
MIL-I-6181	USANAF	MIL-I-6181B	EMI Cntl Aircraft
MIL-STD-188-124A	DOD	-	Grounding, Bonding and Shielding
MIL-STD-202A	DOD	-	Test Methods for Electronic and Electrical Component Parts
MIL-STD-220A	DOD	-	Method of Insertion-- Less Measurement
MIL-STD-248C	DOD	-	Welding and Brazing Procedure and Performance Qualification
MIL-STD-285	DOD	-	Attenuation Measurements for Enclosures, etc. Methods
MIL-STD-461C	DOD	-	Electromagnetic Emission and Susceptibility Requirements for Control of EMT
MIL-STD-1542	DOD	-	EMC and Grounding Reqmts for Space Sys Facilities
NACSEM 5109	NSA	-	Tempest Testing Fundamentals
NACSEM 5110	NSA	-	Facilities Evaluation Criteria--TEMPEST

EP 1110-3-2
31 Dec 90

Table 4-1. HEMP/TEMPEST-related standards and specifications. (Sheet 3 of 3)

Specifications and Standards	Issuer	Superseded by	Short title
NACSEM 5201	NSA	-	TEMPEST Guidelines for Equipment/System Design
NACSEM 5204	NSA	-	Shielding Enclosures
NACSI 5004	NSA	-	TEMPEST Countermeasures for
NACSI 5005	NSA	-	TEMPEST Countermeasures for Facilities Outside the U.S.
NACSIM 5000	NSA	-	TEMPEST Fundamentals
NACSIM 5100A	NSA	-	Compromising Emanations Laboratory Test Reqmts, Electromagnetics
NACSIM 5203	NSA	-	Guidelines for Facility Design and RED/BLACK Installation
NSA 65-5	NSA	-	NSA Specification for RF-Shielded Acoustical Enclosures for Communications Equipment
NSA 65-6	NSA	-	NSA Specification for RF-Shielded Enclosure for Communications Equipment
NSA 73-2A	NSA	-	NSA Specification for Foil RF-Shielded Enclosure

EP 1110-3-2
31 Dec 90

Table 4-2. Peak magnetic field values for close lightning strokes.

Peak current (kA)	Magnetic fields (amps/meters)		
	10 m from flash	100 m from flash	10 km from flash
10	1.6×10^2	16	1.9×10^{-2}
20	3.2×10^2	32	3.8×10^{-2}
30	4.8×10^2	48	5.8×10^{-2}
70	1.1×10^3	1.1×10^2	1.3×10^{-2}
100	1.6×10^3	1.6×10^2	1.9×10^{-2}
140	2.2×10^3	2.2×10^2	2.7×10^{-2}
200	3.2×10^3	3.2×10^2	3.8×10^{-2}

EP 1110-3-2
31 Dec 90

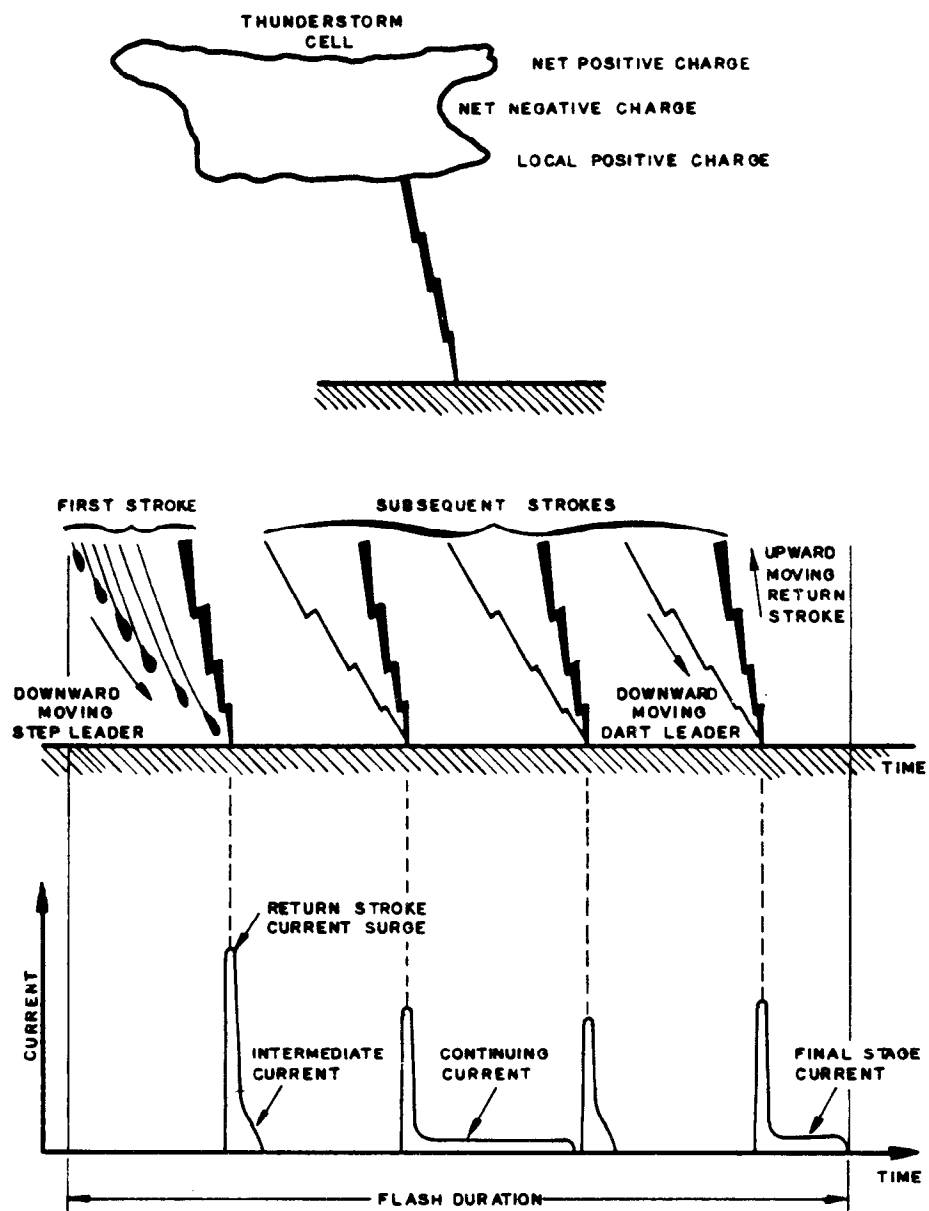


Figure 4-1. Processes and currents occurring in a flash to ground.

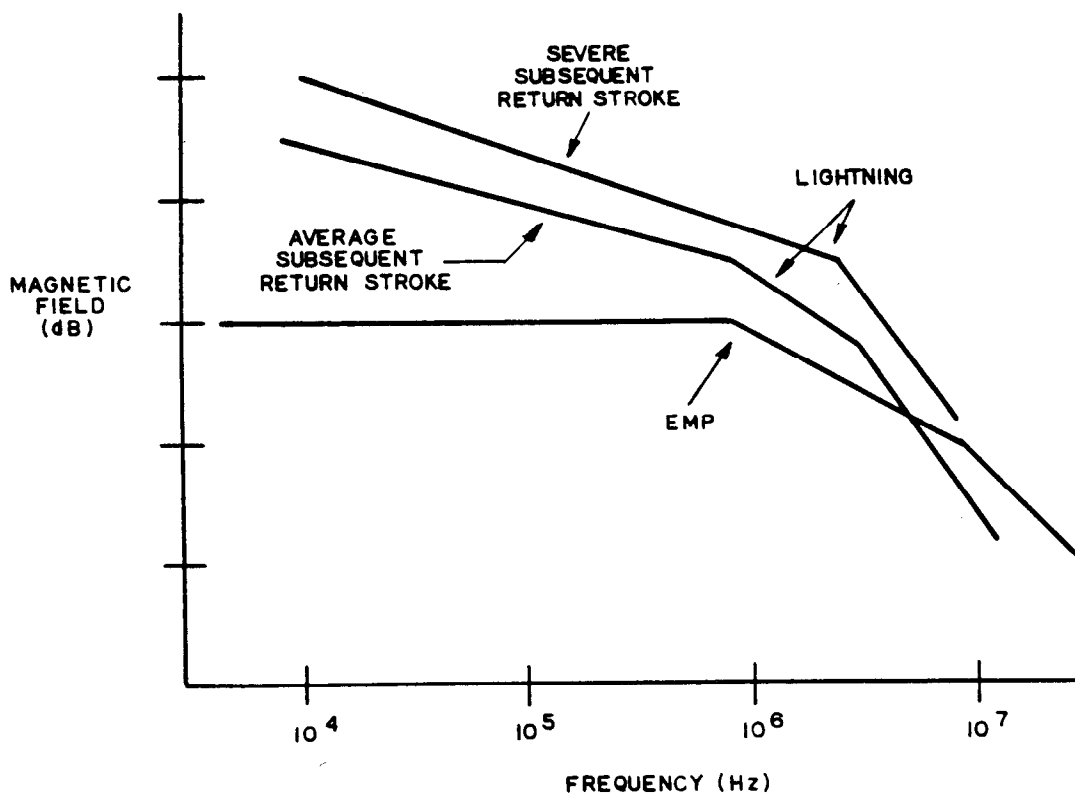


Figure 4-2. EMP and lightning comparison.

EP 1110-3-2
31 Dec 90

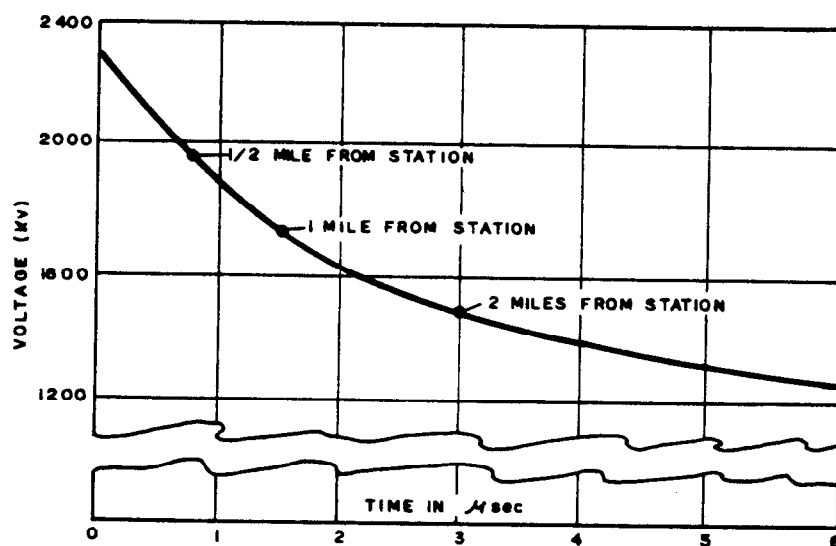


Figure 4-3. Sample power line surge voltage as a function of distance from stroke to line.

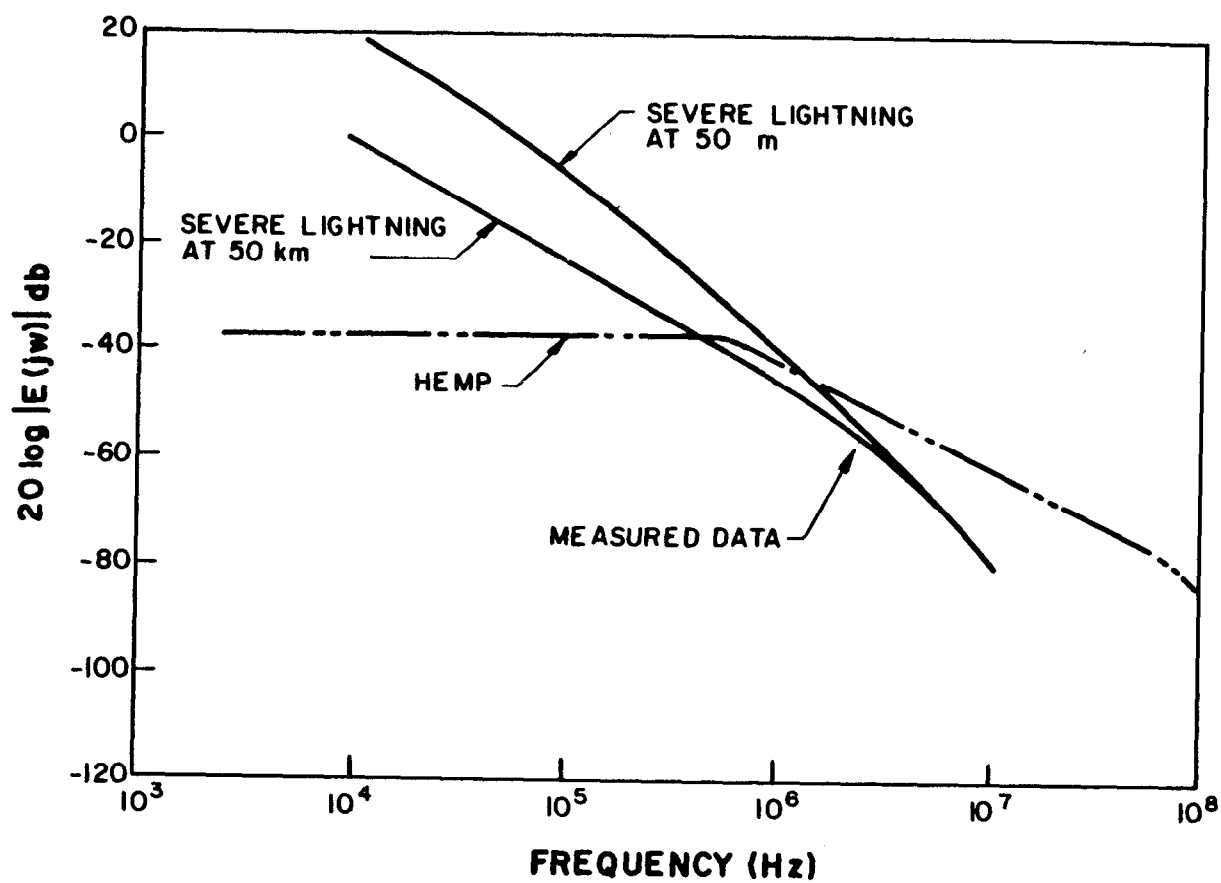


Figure 4-4. Typical spectrum of lightning radiated E-field.

EP 1110-3-2
31 Dec 90

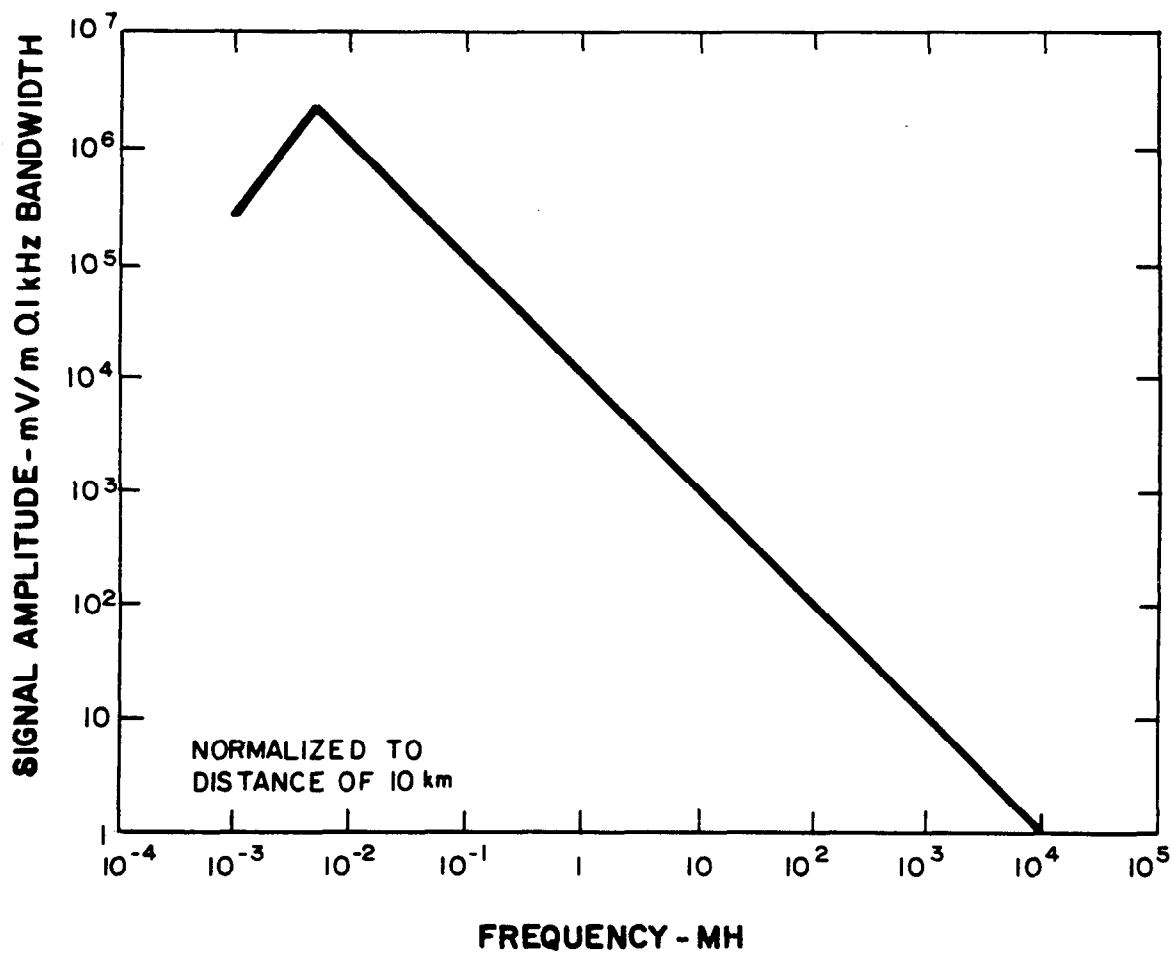


Figure 4-5. Average radiated and static fields for lightning.

CHAPTER 5

FACILITY DESIGN

5-1. Outline. This chapter is organized as follows:

- 5-1. *Outline*
- 5-2. *Theoretical approach to shielding*
 - a. *Shielding theory*
 - b. *Shielding effectiveness*
- 5-3. *Shield design methodology*
 - a. *Shield performance requirements*
 - (1) *Overall system*
 - (2) *Disruptive signals*
 - (3) *System protection concept*
 - (4) *Total isolation to be provided*
 - b. *Shield material and thickness*
 - (1) *Source to shield distance*
 - (2) *Size of protected object*
 - c. *Shield considerations*
 - (1) *Defective seams*
 - (2) *Air apertures*
 - (3) *Seam impedance*
 - (4) *Penetrations*
 - d. *Design approach*
 - (1) *Shielding effectiveness required*
 - (2) *Material and thickness*
 - (3) *Safety margin*
 - (4) *Apertures required*
 - (5) *Aperture control*
 - (6) *Doors*
 - (7) *Seam bonding*
 - (8) *Terminal protective devices*
- 5-4. *Solid shields*
 - a. *Plane wave theory*
 - (1) *Absorption loss and frequency*
 - (2) *Reflection loss and impedance*
 - (3) *Plane wave shielding*
 - (4) *Re-reflection*
 - (5) *Relationships*
 - b. *Absorption loss*
 - (1) *For electromagnetic wave*
 - (2) *Proportions*
 - (3) *Calculating loss*
 - (4) *Example*
 - c. *Reflection loss*
 - (1) *Approximating loss*
 - (2) *Limitation of approximation*
 - (3) *Comparison to absorption loss*

EP 1110-3-2
31 Dec 90

- (4) *Plane wave loss*
- (5) *High-impedance fields loss*
- d. *Re-reflection correction term*
 - (1) *Cause of re-reflection*
 - (2) *Graphs of relationships*
 - (3) *Using graphs for absorption loss*
 - (4) *Using manufacturers' data*
 - (5) *Using graphs for reflection loss*
 - (6) *Example*
- e. *Shielding effectiveness data*
 - (1) *Using absorption loss table*
 - (2) *Variation of absorption loss*
 - (3) *Magnetic field reflection*
 - (4) *Combined absorption and reflection*
 - (5) *Re-reflection factors*
 - (6) *Effect of shield thickness*
 - (7) *Example*
- 5-5. *Shielded enclosures*
 - a. *Enclosure shielding effectiveness*
 - (1) *Low-carbon steel walls*
 - (2) *Layered sheet-steel walls*
 - (3) *Mean shielding effectiveness*
 - b. *Enclosure response to HEMP*
 - (1) *Spherical enclosure and magnetic field*
 - (2) *Spherical enclosure and peak voltage*
 - (3) *Practical enclosures*
- 5-6. *Mesh and perforated shields*
 - a. *Screens and perforated metal shields*
 - (1) *Shielding effectiveness parameters*
 - (2) *Single layer wire cloth and screening*
 - (3) *Using tables*
 - (4) *Shield dimensions*
 - (5) *Galvanized hardware cloth*
 - b. *Honeycomb*
 - (1) *Attenuation*
 - (2) *Rectangular and circular waveguides*
 - (3) *Maintaining airflow through honeycomb*
- 5-7. *Layered shields*
- 5-8. *Reinforcement steel (rebar)*
 - a. *Concepts*
 - (1) *Electrical assumptions*
 - (2) *Reinforcement dimensions*
 - (3) *Magnetic attenuation*
 - (4) *Double-course reinforcement*
 - (5) *Degradation of shielding effectiveness*
 - (6) *Sample calculations*
 - b. *Single-course reinforcing steel construction*
 - c. *Double-course reinforcing steel construction*
 - (1) *Effect of bar size and spacing*

EP 1110-3-2
31 Dec 90

- (2) *Welding intersections and splices*
 - (3) *Welding at corners*
 - (4) *Welded wire fabric*
 - (5) *Attenuation from welded wire fabric*
- 5-9. *Earth cover electromagnetic wave attenuation*
 - a. *Absorption loss*
 - b. *Reflection loss from soils*
- 5-10. *Shield joints and seams*
 - a. *Shield fabrication*
 - b. *Seam bonding*
 - (1) *Metal thickness*
 - (2) *Mating surfaces*
 - (3) *Soldering*
 - c. *Mechanical joining (shielding reqts below 60 dB)*
 - (1) *Mechanical seams*
 - (2) *Seams with gaskets*
 - (3) *Gasket selection-- summary*
- 5-11. *Internal cable and connectors*
 - a. *Shielding effectiveness*
 - (1) *Analysis methods*
 - (2) *Transfer impedance*
 - (3) *Cable length*
 - (4) *Cable shielding methods*
 - b. *Braided cable*
 - c. *Tape-wound shield*
 - d. *Twisted-pair cable*
 - (1) *Using twisted pairs*
 - (2) *Shield termination*
 - e. *Cable connectors*
 - (1) *Transfer impedance*
 - (2) *Common connectors*
 - (3) *Connector materials and finishes*
 - (4) *Threaded connectors*
 - (5) *Bayonet connectors*
 - (6) *Using gaskets*
- 5-12. *Conduit and conduit connections*
 - a. *Solid conduit*
 - (1) *Coupling mechanism*
 - (2) *Connectors*
 - (3) *Flaw impedance*
 - (4) *Coupler threads*
 - (5) *Leakage at threads*
 - (6) *Diffusion current*
 - b. *Flexible conduit*
 - (1) *When required*
 - (2) *Metal bellows*
 - c. *Conduit unions*
 - (1) *Sources of leakage*
 - (2) *Pulse excitation tests*

EP 1110-3-2
31 Dec 90

- (3) *Descriptions of unions*
- (4) *Conclusions about unions*
- d. *Conduit fittings and junction boxes*
 - (1) *Sources of leakage*
 - (2) *RF interference gaskets*
 - (3) *Effect of no cover*
 - (4) *Summary*
- 5-13. *Terminal protection for electrical penetrations*
 - a. *Transient suppressors*
 - (1) *Spark gaps*
 - (2) *Metal oxide varistors*
 - (3) *Silicon avalanche suppressors*
 - (4) *Semiconductor diodes*
 - (5) *Features of transient suppressors*
 - (6) *Installation criteria*
 - (7) *Comparison of terminal protection devices*
 - b. *Filters*
 - (1) *Classes*
 - (2) *Reactive versus lossy filters*
 - (3) *Filter uses*
 - (4) *Filter installation and mounting*
 - (5) *Specifying filters*
 - c. *Common mode rejection (CMR)*
 - (1) *Balanced cables*
 - (2) *Improving CMR*
 - (3) *Examples of balanced cable designs*
 - d. *Isolation*
 - (1) *Fiber optic cables*
 - (2) *Waveguides for fiber cables*
 - (3) *Electro-optic isolators*
 - (4) *Microwave isolation technique*
- 5-14. *Apertures*
 - a. *Shielding*
 - (1) *Doors/personnel entry*
 - (2) *Other access ports*
 - (3) *Air ducts*
 - b. *Waveguide-below-cutoff (WBC)*
 - (1) *Tunnels*
 - (2) *Tunnels and grills*
- 5-15. *Utility penetrations*
 - a. *Overview*
 - b. *Conductive penetrations*
 - c. *Nonconductive penetrations*
 - (1) *Pipes carrying fluids*
 - (2) *Impacts of fluids on waveguides*
- 5-16. *Bonding*
 - a. *Purpose*
 - (1) *Potential differences*
 - (2) *External fields*

*(3) Equipotential surfaces**b. Techniques*

- (1) Direct bonding*
- (2) Indirect bonding*

c. Bond protection

- (1) Source of corrosion*
- (2) Galvanic series*
- (3) Electrolysis*
- (4) Effect of moisture*
- (5) Summary*

*5-17. Grounding**a. Concepts*

- (1) Lightning protection*
- (2) Grounding buildings*
- (3) Interfacing electronic equipment*
- (4) Grounding system as electrical circuit*

b. Techniques

- (1) Zonal boundaries*
- (2) Soil as a dissipative medium*
- (3) Alternate grounding means*
- (4) Ring ground*
- (5) Configuration of collectors*
- (6) Single-point grounding*

*5-18. Cited references**5-19. Uncited references**5-2. Theoretical approach to shielding.*

a. Shielding theory. The shielding theory that best applies to engineering calculations is based on an analogy to transmission line theory (ref 5-1). The transmission through an electromagnetic shield where the EM wave fronts coincide with the shielding boundary configuration is mathematically modeled in a way analogous to that in which a two-wire transmission line transmits electric current and voltage. Consider an incident EM wave with a power P in watts per square meter striking a flat shield as in figure 5-1. When the wave meets the first surface of the shield, part (P_{R1}) of the incident power (P_{in}) reflects back toward the source. The rest (P_{t1}) penetrates the shield and starts to propagate through it. The ratio of reflected power to incident power (P_{R1}/P_{in}) depends on the shield material's intrinsic impedance and the wave impedance (ratio of electric field strength to magnetic field strength) of the incident wave in the same way as at the junction of two transmission lines with different characteristic impedances. Part of the power transmitted into the shield (P_{t1}) is changed into heat as the wave moves through the shield. This energy loss is called "absorption loss" and is analogous to the dissipated energy inside a lossy transmission line. Of the power propagating through the shield toward the second surface, part is reflected back into the shield and the rest (P_{out}) is transmitted through the surface and beyond the shield. If the absorption loss in the shield is small (less than 10 decibels), a significant part of the

EP 1110-3-2

31 Dec 70

power reflected at the second surface (P_2) propagates back to the first surface, where some of it is re-reflected back into the shield. At each surface, part of the energy is reflected and part is transmitted, contributing to an increase in the total energy propagated through the shield.

b. Shielding effectiveness. A shield's effectiveness is given in terms of how much it can reduce the incident EM field strength. Shielding effectiveness (SE) is therefore defined as the ratio of the field strength without the shield to the field strength with the shield. Because of the wide ranges in this ratio, SE is commonly expressed (in decibels) as--

$$\begin{aligned} SE &= 20 \log (E_1/E_2) = 20 \log (H_1/H_2) \\ &= 10 \log (P_1/P_2) \end{aligned} \quad (\text{eq 5-1})$$

where E_1 is the electric field strength, H_1 is the magnetic field strength, and P_1 is the power density of the incident wave. E_2 , H_2 , and P_2 are corresponding values with the shield in place. The SE of a given material is a complex function with many parameters. The most notable of these are the frequency and impedance of the impinging wave and the intrinsic characteristics of the shield material. In practice, the SE of enclosures is of primary concern. Thus, the above expressions are generally used to calculate the effectiveness (in decibels) of the shield material as well as the effectiveness of shield penetration and aperture treatments.

5-3. Shield design methodology. In general, 100-decibel shields require welded steel panels, whereas 50- to 60-decibel shields can be constructed using bolt-together panels. Lower shielding levels, as may be suitable for TEMPEST, can be provided with thin metals or foils. After establishing the required shielding level, the designer must consider the shield material thickness, material properties (permeability and conductivity), apertures, penetrations, geometry, construction--including solid sheet materials or screens and seam-joining techniques (e.g., bolted or welded), and the performance requirements (shielding effectiveness versus frequency). This paragraph addresses the approach to designing a shield in qualitative terms. The rest of this chapter (paragraphs 5-4 through 5-17) presents the quantitative data and formulas for shield design.

a. Shield performance requirements. The first step in designing an enclosure shield, whether for a large facility or an equipment enclosure, is to define the SE required. An enclosure's SE is not constant with frequency and this fact is usually taken into account in the SE definition. The shield design, shield material and thickness, and aperture penetration control affect the SE frequency dependence.

(1) Overall system. To establish the shield performance requirements, the overall system (facility and associated electronic and electrical systems) must be considered. The damage and/or upset levels at the terminals of equipment housed in the facility should be known. These values can be

obtained analytically, through laboratory experiments, or in some cases, from existing data bases for the same or similar equipment.

(2) Disruptive signals. Second, the way in which disruptive voltages and currents are coupled to the sensitive equipment's terminals should be determined. For example, they may be induced by penetrating magnetic or electric fields or by currents being conducted on cables that penetrate the facility (or possibly by cable-to-cable coupling of the cables that penetrate the facility). If the disruptive signals are coupled due to fields, protection is achieved by shielding the interior cables, shielding the entire facility, providing protection at the equipment terminals, or a combination of these techniques. If the signals are the result of energy injected by a shield-penetrating conductor, then these penetrants can be controlled at the point of entry to the enclosure or at the equipment terminals.

(3) System protection concept. The overall sensitive systems' protection design concept also plays a major role. That is, the choice of shielding concept (a low-performance facility shield in combination with interior cable and equipment shields--a multi-EM barrier approach--or a single barrier, high-performance facility shield) determines how the shield should be designed. (Chapter 3 discusses shielding concepts.) In general, this decision is influenced by economics, future expansion plans, the need for flexibility in system configuration changes, and maintenance capability.

(4) Total isolation to be provided. To establish the shield performance requirements, it is necessary to know the total isolation (protection level) that must be provided. For example, low-frequency magnetic field (low impedance fields) shielding is much harder to obtain than are high-frequency plane wave and electric field (high impedance fields) shielding. However, to obtain the same overall interior system isolation, a lower SE may be required from the shield for low-frequency magnetic fields due to the way in which magnetic fields couple to cables and circuits. For magnetic field coupling, a time-varying magnetic field is required (or motion of a conductor in a stationary magnetic field which is generally not of concern). Faraday's Law states that the voltage induced in a conducting loop is directly proportional to the time rate of change of the magnetic field and the area of the loop (i.e., $V_{\text{induced}} = B A$, where B represents the time derivative of the magnetic field and A is the cross sectional area of the conducting loop normal to the magnetic field). This relationship implies that if B is small (low frequency or slow rise and fall times for a transient) or A is small, the voltage induced is small. Thus, less shielding is required for the same loop-induced voltage if the frequency is low.

b. Shield material and thickness. An enclosure's SE results from losses due to both reflection and absorption. The most common theory for calculating SE is the plane wave (or transmission line) theory presented in paragraph 5-4 below. Application of this theory requires that certain conditions be met as described in paragraphs (1) and (2) below.

EP 1110-3-2
31 Dec 90

(1) Source to shield distance. The source-to-shield distance must be greater than $\text{wavelength}/2(\pi)$ to be considered a plane wave. At this distance, the wave front is still spherical but can be assumed to be planar with minimal error for the analysis. At distances less than this, near-field calculations must be used. For the HEMP spectrum, the lowest frequency of interest is 10 kilohertz which corresponds to a wavelength of 30 kilometers. Plane wave criteria require a source-to-object distance of approximately 5 kilometers, which is met for HEMP with HOB \geq 30 kilometers. In the near-field, the electric and magnetic fields must be analyzed separately.

(2) Size of protected object. The object size must be greater than 2 to 3 wavelengths in the smallest dimension or the infinite plane shielding theory no longer directly applies. If reflection loss is neglected, the infinite plane shielding theory can be extended to objects as small as 0.1 wavelength. Neglecting reflection losses provides a conservative estimate. As can be seen from the maximum wavelength associated with HEMP, the case of an object size greater than 2 to 3 wavelengths is not met for any enclosure.

(a) Another situation in which reflection losses are ignored is when the enclosure currents are induced primarily by conducted currents collected by external cables, pipes, etc., where the cable shields and pipes are terminated on the enclosure. The field reflection losses do not enter into the calculation in this case. There is some reflection loss at the entry point, but for a worst-case analysis, this loss can be ignored. These conducted enclosure currents are obtained by analyzing the coupling of the complete system or from laboratory scale model tests.

(b) Both the reflection loss and absorption loss depend on the shield's material properties. The absorption losses increase as the square root of frequency and material properties, and directly with material thickness. Reflection losses at all frequencies for electric and plane wave fields, however, remain quite high (more than 60 decibels for iron and more than 68 decibels for copper at 10 gigahertz (see para 5-4e below). The reflection losses for magnetic fields are low (less than 50 decibels) at frequencies below 100 kilohertz for copper and aluminum and approximately 100 megahertz for iron. The result is that any relatively good conductor (i.e., copper, aluminum, iron) will provide good SE at all frequencies for electric and plane waves. The design problem with regard to material properties and thickness, therefore, is related to obtaining the required SE for magnetic fields at frequencies below approximately 100 kilohertz.

(c) To obtain good SE for magnetic fields at low frequencies due to the enclosure size restrictions cited above, it is necessary to increase the absorption losses. This condition can be achieved by increasing either the permeability or the conductivity. Copper is one of the best conductors, but still falls short of adequate absorption loss unless excessive thicknesses are used. Therefore, the remaining option is to increase the permeability. The permeability of all materials decreases with frequency, so care must be taken in the choice of material. The conductivity of high-permeability materials is

less than that of copper which reduces high-frequency SE; however, the high-frequency SE of high-permeability materials is usually adequate. The design choice is therefore to select a material and thickness for which low-frequency magnetic field absorption loss combined with the reflection loss, if possible, provide the required SE at the lowest frequency of interest (10 kilohertz for HEMP).

c. Shield considerations. The construction techniques and penetrations generally determine a shield's high-frequency performance. When openings in a shield become greater than approximately wavelength/6, significant fields can penetrate to the interior. For example, suppose a shield is composed of the reinforcement bars in concrete; even if the bars are intersection-welded, a spacing between bars of greater than wavelength/6 results in low SE. For the commonly used double exponential HEMP, the highest frequency of interest is 200 megahertz (see chap 2) and this spacing requirement is less than 0.15 meter. Bar spacing is more critical for EMI which has frequencies in the 11 to 40 gigahertz range, and relates to fields present in the entire interior volume of the enclosure. Higher fields will be present near the aperture for aperture dimensions that are small compared with a wavelength so that the penetrating fields are nonpropagating. These fields decrease in magnitude as the inverse cube of the distance from the aperture.

(1) Defective seams. Apertures resulting from seams with defects also can introduce field-coupling inside the enclosure. If these defects have openings that are nonpropagating (i.e., much smaller than the wavelength), the fields again decrease in magnitude as the inverse cube of distance from the aperture. For high shield currents and susceptible equipment located near the shield, these fields could cause potential disruption. This upset can occur even for low-frequency shield currents due to the redistribution of currents on the shield caused by the seam apertures.

(2) Apertures. Apertures for air inlets, exhausts, and similar features also must be sized and treated to maintain high-frequency SE. These openings are designed as waveguide-below-cutoff structures.

(3) Seam impedance. Seam impedance is of concern since induced currents flowing across seams can introduce potential drops over the seams, which will result in reradiation inside the shielded volume. These potential drops can also cause problems when the shield is used in the grounding system.

(4) Penetrations. Configuration control must be considered during the design phase. Conducting penetrations must be bonded carefully around the penetrant periphery (360 degrees) to the shield entry plate to prevent aperture coupling to the facility interior or to inner conductors of shielded cables. Nonconducting penetrations must be treated as apertures in the shield and given WBC treatment.

d. Design approach. In designing a facility shield, the following steps should be performed in the order listed.

EP 1110-5-2
31 Dec 90

(1) Shielding effectiveness required. Determine the exterior shield performance (SE) as a function of frequency and interior equipment susceptibility. Repeat this process for the interior shield (second barrier) if one will be used.

(2) Material thickness. Select the material and material thickness to obtain the necessary SE at the lowest frequency of concern and for the field impedance of interest for all shield barriers, internal and external. For small (less than 2 to 3 wavelengths) enclosures or conducted enclosure currents, the reflection loss can be ignored.

(3) Safety margin. Provide a safety margin in the SE to account for corner effects in low-performance shields (less than 60 decibels).

(4) Apertures required. Determine which apertures must be open and apply the necessary protective design techniques to achieve the same level of attenuation as that of the shielded enclosures.

(5) Aperture control. Design seams and treatment to control aperture size such that attenuation through apertures is the same or higher than that for enclosure SE.

(6) Doors. Select or design doors to achieve the same decibel attenuation as that of the enclosure. Maintenance of gaskets, spring fingers, and contact surfaces also should be considered.

(7) Seam bonding. Seam bonding must be low-impedance type.

(8) Terminal protective devices. Provide for penetrant bonding, entry plate, and entry vault to house terminal protective devices if required.

5-4. Solid shields.

a. Plane wave theory. The plane wave (or transmission line) theory is the basis for the most commonly used approach to shielding design. For a plane wave normally incident on a large plane sheet of metal, the SE is (ref 5-2)--

$$SE = A + R + B \quad (\text{eq 5-2})$$

where A = absorption loss of the material (decibels), R = single reflection loss (decibels), and B = re-reflection correction term (decibels).

(1) Absorption loss and frequency. For a given material, absorption loss (in decibels) at a specific frequency is a linear function of the material thickness. Characteristics of the material that influence this loss are conductivity and permeability. Absorption loss is largely independent of

wave impedance and is the same for electric, magnetic, and plane wave fields.

Magnetic field shielding at low frequencies mainly depends on absorption losses since reflection losses decrease with frequency. In addition, the shield must approximate an infinite sheet. For practical cases, the smallest shield enclosure dimension must be greater than 2 to 3 wavelengths to achieve significant reflective loss. Electric fields, however, are readily stopped by metal shields because large reflection losses are easy to obtain for any good conductor.

(2) Reflection loss and impedance. The single reflection loss term depends on the degree of mismatch between the impedance of the field and that of the shield. The impedance of the impinging wave is given by the ratio of its electric to magnetic field strength in space in the vicinity of the shield. A shield's impedance is a complex function of its electrical properties, thickness, and impinging wave frequency. In general, the shield impedance is low for highly conducting shields and increases for shields with high permeability.

(3) Plane wave shielding. For the reflected wave to be as large as possible or for the reflection loss to be high, the shielding material should have an impedance much lower than the wave impedance. To shield against plane waves, any good conductor is suitable (e.g., copper, aluminum, and steel).

(4) Re-reflection. The re-reflection correction term is a complex function of material, dimensions, and frequency. The term can be ignored if the absorption loss exceeds 10 decibels. If the absorption loss is less than 10 decibels, however, the correction term should be determined.

(5) Relationships. The absorption loss, single reflection loss, and re-reflection correction terms can be approximated by relationships involving shield thickness (t), material conductivity (g), material permeability (u), and frequency (f). Since reflection loss depends on the incident wave's impedance, relationships are given for low-impedance fields (Z less than 377 ohms; magnetic fields), high-impedance fields (Z greater than 377 ohms; electric fields), and plane wave fields ($Z = 377$ ohms).

b. Absorption loss.

(1) For electromagnetic wave. The absorption loss for an EM wave passing through a shield of thickness t can be shown by--

$$A = K_1 t \quad f u_r g_r \quad (\text{decibels}) \quad (\text{eq 5-3})$$

where $K_1 = 131.4$ if t is expressed in meters, $K_1 = 3.34$ if t is expressed in inches, t = shield thickness, f = wave frequency (hertz), u_r = permeability of shield material relative to copper, and g_r = conductivity of shield material relative to copper.

EP 1110-3-2
31 Dec 90

(2) Proportions. The absorption loss (in decibels) is proportional to the thickness of the shield and increases with the square root of incident EM wave frequency. The absorption loss also increases with the square root of the product of the permeability and conductivity (both relative to copper) of the shield material. As noted before, absorption loss is independent of wave impedance.

(3) Calculating loss. A simple approach to calculating the required absorption loss is to--

(a) Estimate the reflection loss (if applicable, depending on the enclosure size and conducted current on the enclosure) for the type of field.

(b) Subtract the reflection loss from the SE requirement.

(c) The difference from (b) above must be obtained from the absorption loss as in (d) below. If the required absorption loss is less than 10 decibels, then the correction factor must be applied to the reflection loss in (a) above and steps (b) through (e) repeated.

(d) Calculate the absorption loss per mil thickness from equation 5-3 for the material chosen.

(e) Calculate the material thickness required by dividing the required loss by the loss per mil. If this thickness is excessive because of weight, cost, or other factors, select a new material and repeat the calculation.

(4) Example. As an example, assume the following shielding system design:

(a) Facility size = 100 by 100 by 20 meters.

(b) System sensitivity (V_{upset}) = 2 volts at equipment terminals.

(c) Maximum loop size between equipment = 2 meters squared.

(d) Incident field = HEMP; $H_e = 133$ amps per meter, $E_e = 50$ kilovolts per meter.

(e) Based on the previous discussion, since the facility size is much less than the wavelength, assume no reflection losses.

(f) Estimate $H_{i_{\text{max}}}$ (internal time rate of change of magnetic field). The interior loop coupling is given by Faraday's Law of Induction as (eq 5-4):

EP 1110-3-2
31 Dec 90

$$V = u \dot{H}_{i_{\max}} A \quad (\text{eq 5-4})$$

where $u = u_0 = 4(\pi) \times 10^{-7}$ (free space or air); A = loop area; and V = maximum allowable voltage transient at equipment terminals. Thus--

$$2 = V = [4(\pi) \times 10^{-7}] \dot{H}_{i_{\max}} \quad (2)$$

$$\dot{H}_{i_{\max}} = \frac{V}{uA} = 4u^2 \times 10^7 \quad (2)$$

$$= 8 \times 10^5 \text{ amps/meter/second}$$

(g) Estimate $\dot{H}_{i_{\max}}$:

$$\dot{H}_e = 133 \text{ amps/meter (free field)}$$

$$t_r = \text{pulse rise time} = 10 \text{ nanoseconds}$$

$\dot{H}_{e_{\text{surface}}} = 2\dot{H}_e = J$, the field or current density at the conducting surface.

$$J = 266 \text{ amps/meter}$$

$$\dot{j} = J/t_r = \frac{266}{10^8} = 2.66 \times 10^{10} \text{ amps/meter/second and--}$$

$$\dot{H}_{i_{\max}} = \frac{\dot{j}}{2} = 1.33 \times 10^{10} \text{ amps/meter/second}$$

(h) Estimate the required SE:

$$SE = 20 \log \left(\frac{\dot{H}_{i_{\max}}}{\dot{H}_{e_{\text{surface}}}} \right) = 20 \log \left(\frac{8 \times 10^5}{2.66 \times 10^{10}} \right)$$

$$= 90 \text{ decibels}$$

EP 1110-4-2
31 Dec 90

(i) For worst-case analysis, assume that all attenuation must be achieved through absorption and assume a lowest frequency of 10 kilohertz for HEMP.

(j) Calculate the absorption loss and material thickness:

$$A = 90 \text{ decibels (from (h) above)}$$

$$A = 3.34 t (u_r g_r f)^{0.5}$$

$$f = 10^4 \text{ hertz.}$$

For steel (sheet metal)--

$$u_r = 1000$$

$$g_r = 0.17$$

Solving for t (thickness) yields--

$$t = \frac{A}{3.34 (u_r g_r f)^{0.5}}$$

Substituting--

$$t = \frac{90}{3.34 (1000 \times 0.17 \times 10^4)^{0.5}}$$

$$t = 20 \text{ mils.}$$

For copper--

$$u = 1, g_r = 1$$

$$t = 90 / [3.34 (10^4)^{0.5}]$$

$$t = 269 \text{ mils.}$$

(k) The calculation in (j) above is for a worst case since it assumes all the energy is at 10 kilohertz and no reflection losses occur. To solve the problem more rigorously, it would be necessary to obtain $H_{i\max}$ derivative on a frequency-by-frequency basis, compare it with the spectrum $H_{i\text{surface}}$ derivative on a point-by-point basis, and obtain the SE as a function of frequency. Since the steel result does not incur any great penalty (in fact, an even heavier material could be used since it would result in lower construction costs) it is generally not necessary to do a rigorous analysis for the envelope shield of a facility. If weight were a critical

EP 1110-3-2
31 Dec 90

factor, the longer calculation may be justified. Further, this worst-case analysis should provide a safety margin without added SE requirements for corner effects. Although this example is greatly simplified, it represents the basic method for choosing a material and thickness.

c. Reflection loss.

(1) Approximating loss. For magnetic (low-impedance) EM fields, the low impedance reflection loss can be approximated as (eq 5-5):

$$R_m = 20 \log \left[\frac{C_1}{r (fg_r/u_r)^{0.5}} + C_2 r fg_r/u_r + 0.354 \right] \quad (\text{eq 5-5})$$

where r = distance from the EM source to the shield and f , u_r , and g_r are as stated for equation 5-3. The constants C_1 and C_2 depend on the choice of units for the distance, r , as given in table 5-1.

(2) Limitation of approximation. For HEMP, the source region is remote enough that the waves are essentially plane waves and equation 5-5 does not apply. Equation 5-5 is for source-to-object distances (r) much less than wavelength/ $2(\pi)$. The product $fr \ll 2 \times 10^9$, where r is in inches, also must be met. The source distance (r) must be less than 5000 meters at a frequency of 10 kilohertz, which is the lowest frequency of concern for HEMP. For example, the magnetic field reflection loss at $r = 100$ meters and $f = 10$ KHz is--

$$\begin{aligned} R_m &= 20 \log \left[\frac{0.0117}{100 (f)^{0.5}} + 5.35 (100) f + 0.354 \right] \\ &= 20 \log [1.2 \times 10^{-6} + 53500 + 0.354] \\ &= 95 \text{ decibels.} \end{aligned}$$

(3) Comparison to absorption loss. As with absorption loss, the reflection loss for low-impedance fields depends on the electrical properties (u_r , g_r) of the shield material and the EM wave frequency. In contrast, reflection loss depends on the distance from the source to the shield rather than on the shield thickness, except for very thin shields (where thickness is less than skin depth).

(4) Plane wave loss. The plane wave reflection loss for a plane wave impinging on a uniform shield is given by equation 5-6:

EF 1110-3-7
31 Dec 90

$$R_p = 168 - 20 \log \left(\frac{fu_r}{g_r} \right) \quad (\text{eq 5-6})$$

where g_r , u_r , and f are as defined for equation 5-3. The plane wave reflection loss declines as the wave frequency increases and is better for shielding materials with lower u_r/g_r ratios. For example, the plane wave reflection loss for copper at a frequency of 1 megahertz is--

$$\begin{aligned} R_p &= 168 - 20 \log f \\ &= 168 - 60 \\ &= 108 \text{ decibels.} \end{aligned}$$

(5) High-impedance field loss. For electric (high-impedance) EM fields, the high-impedance reflection loss is approximated by equation 5-7:

$$R_E = C_3 - 20 \log r \frac{u_r f^3}{g_r} \quad (\text{eq 5-7})$$

where $C_3 = 322$ if r is in meters, 354 if r is in inches; r is the source-to-object distance, and g_r , u_r , are the conductivity and permeability relative to copper. High-impedance EM wave reflection loss depends on the separation distance, r , between the EM source and the shield, as does low-impedance reflection loss. This loss declines as the frequency increases and is higher when the g_r/u_r ratio is higher. For electric fields, the conditions $r \gg \text{wavelength}/2(\pi)$ and $fr \ll 2 \times 10^9$ should be met. For example, the electric field reflection loss for copper when $r = 100$ meters and $f = 100$ kilohertz is--

$$\begin{aligned} R_E &= 322 - 20 \log 100 f^3 \\ &= 322 - 190 \\ &= 132 \text{ decibels.} \end{aligned}$$

d. Re-reflection correction term.

(1) Cause of re-reflection. For shields in which the absorption loss (A) is fairly large, say at least 10 decibels, the energy reflected back into the shield at the second surface does not contribute significantly to the wave propagated through and beyond the shield. However, when the shield's absorption loss is low, a significant amount of energy is re-reflected and

finally propagates into the area to be shielded. Thus, for shields with low absorption loss (less than 10 decibels), SE is calculated as the sum of the absorption loss (A), the reflection loss (R), and a re-reflection correction factor (B). The correction factor in decibels is--

$$B = 20 \log [1 - X10^{-A/10} (\cos 0.23A - j\sin 0.23A)] \quad (\text{eq 5-8})$$

where A is the shield's absorption loss (from eq 5-3) and X is the two-boundary reflection coefficient. X depends on both the shield's characteristic impedance and the impinging EM wave's impedance; X is equal to 1 for all practical purposes except for low-frequency shielding against magnetic fields (fig 5-2) (ref 5-3).

(2) Graphs of relationships. The relationships for SE given in equations 5-3 through 5-8 have been plotted as graphs for ease of use. Figures 5-3 through 5-8 are nomographs and curves that permit graphical solutions of these relationships. The nomographs in figures 5-3 through 5-6 give solutions for absorption loss and magnetic field, electric field, and plane wave reflection loss, respectively. Figures 5-7 and 5-8 give solutions for the re-reflection loss in terms of the ratio of the shield impedance (Z_s) to the impedance of the incident magnetic field (Z_m). This ratio (K_w) is given by either figure 5-7 or equation 5-9:

$$K_w = \frac{Z_s}{Z_m} = \frac{1.3}{\left(\frac{g_r f}{u_r} \cdot r \right)^{0.5}} \quad (\text{eq 5-9})$$

where g_r and u_r , are the conductivity and permeability relative to copper; f is frequency; and r is source-to-object distance (ref 5-3). Once determined, the ratio K_w is used with figure 5-8 to determine the re-reflection loss, B.

(3) Using graphs for absorption loss. As an example of how to use the figures, consider a calculation for absorption loss. On the nomograph in figure 5-3, draw a straight line between a point on the right-hand vertical scale that corresponds to the metal involved and the correct point on the thickness scale (center scale on the nomograph). Mark the point at which the straight line crosses the unlabeled pivot line and the frequency of interest (left-most vertical scale). Read the absorption loss off the compressed scale just to the left of the thickness scale. This figure shows the determination of absorption loss for a 15-mil sheet of stainless steel at 1 kilohertz. First, line 1 is drawn between stainless steel on the right-hand scale and 15 mils on the thickness scale. Then line 2 is drawn between 1 kilohertz on the left-hand scale and the crossover point. The absorption loss is 3 decibels.

(4) Using manufacturers' data. If the metal of interest is not given on the right-hand scale, calculate the product of the relative conductivity

EP 1110-3-2
31 Dec 70

(g_r) and the relative permeability (u_r) from figures given in the manufacturer's data sheets and use this value as the right-hand point for line 1.

(5) Using graphs for reflection loss. Since the total SE is the sum of the absorption loss and reflection loss, the procedure for determining reflection loss using the nomographs in figures 5-4 through 5-6 is similar to that described for absorption loss. The right-hand scale in these three nomographs is based on the ratio of relative conductivity to relative permeability instead of the product of the two as used in the absorption loss nomograph.

(6) Example. Except for very thin shields with little absorption loss, re-reflections are unlikely to affect SE. Re-reflection loss estimates using figures 5-7 and 5-9 are necessary only if the absorption loss is less than about 10 decibels. Figure 5-7 shows an example of computing K_w for copper at a frequency of 1 kilohertz and a source-to-shield distance of 2 inches, yielding a K_w of 2.2×10^{-2} . For a 10-mil-thick sheet of copper at this frequency, the absorption loss (from fig 5-3) will be about 1 decibel. Thus, in figure 5-6, for a K_w of 2.2×10^{-2} and an absorption loss of 1 decibel, the re-reflection loss would be about 10 decibels. This example applies to low-impedance magnetic fields which are not plane waves. The re-reflection term (B) is presented (table 5-8 in para (5) below) for electric and plane wave fields for iron and copper; or, it can be calculated using equation 5-8. HEMP fields are essentially plane wave fields.

e. Shielding effectiveness data. The data in tables 5-2 through 5-4 show the SE of common metals. In addition, quick estimates for almost any frequency can be obtained using the nomographs in figures 5-6 through 5-8. The tables and figures for these data provide an easy-to-use reference of SE when they include the shield material and frequency of interest.

(1) Using absorption loss table. Table 5-2 gives electrical properties (g_r and u_r) of common shielding materials. Since u_r is frequency-dependent for magnetic materials, it is given for a typical shielding frequency of 150 kilohertz. The relative permeability decreases with increasing frequency. A typical sample of iron, for example, has a u_r of 1000 up to 150 kilohertz. At 1 megahertz, it drops to 700 and continues to fall to a value of $u = 1$ at 10 gigahertz. Materials with very high permeability have u_r values that drop much faster. For these high-permeability materials, $u_r = 1$ should be used above 1 megahertz in most cases. For the exact values, manufacturer's data should be consulted since these values differ with each material (e.g., Mu-metal, Permalloy, etc., which are trade names). At the higher frequencies (above 1 megahertz), a large u_r value is unimportant since the reflection losses and absorption losses are high even for nonmagnetic materials. u_r is important only for low-frequency (below 100 kilohertz) magnetic shielding. The last column gives values of absorption loss in decibels per mil since a given material's absorption loss is proportional to its thickness.

(2) Variation of absorption loss. Table 5-3 shows the variation of absorption loss with frequency for copper, aluminum, and iron. Iron has a higher absorption loss than copper at low frequencies, whereas copper has the higher loss at higher frequencies. Figure 5-9 shows curves of absorption loss as a function of frequency for certain thicknesses of copper and steel shields. For example, a 50-mil steel shield provides significant absorption losses at frequencies above 1 kilohertz.

(3) Magnetic field reflection. Table 5-4 gives reflection losses for copper, aluminum, and iron for electric, magnetic, and plane wave fields. Values in this table, derived from data in table 5-3, suggest why shielding against magnetic fields is of major concern in shield design: the magnetic field reflection loss is relatively low for all three materials. The electric field and plane wave reflection losses are high enough to provide adequate shielding for most requirements, however, especially over the EMP frequency spectrum.

(4) Combined absorption and reflection. Tables 5-5 through 5-7 show the combined absorption and reflection SE for magnetic, plane wave, and electric fields, respectively, for certain frequencies. The SE values for magnetic and electric fields were derived for a source-to-shield spacing (r) of 12 inches, which represents high- or low-impedance near fields. These data again show that electric field and plane wave shielding are relatively easy. Even for magnetic fields, shields of reasonable thickness provide significant shielding (for example, 69 decibels for copper at 150 kilohertz).

(5) Re-reflection factors. Table 5-8 shows the re-reflection (B) factors for copper and iron in electric, magnetic, and plane wave fields for various frequencies and shield thicknesses. For frequencies above 10 kilohertz and shield thicknesses greater than 10 mils, re-reflection losses are negligible for both copper and iron. If the shield is electrically thin (absorption loss less than 10 decibels), the re-reflection factor must be determined to define the total SE. Figure 5-10 shows how absorption losses for copper and iron, in decibels per mil, vary with frequency.

(6) Effect of shield thickness. Tables 5-9 through 5-11 give the total SE in electric, magnetic, and plane wave fields for copper and steel shields of certain thicknesses at a source-to-shield distance of 165 feet. Figures 5-11 through 5-13 illustrate the data in these tables. Figure 5-13 suggests that, for most EM environments, including HEMP, a 50-mil shield would greatly reduce incident energy--on the order of 100 decibels or more for frequency components above 1 kilohertz.

(7) Example. As an example of how to use the above data in estimating SE, assume that the SE of a 10-mil-thick copper sheet exposed to a plane wave field is to be determined at a frequency of 150 kilohertz. From table 5-3, the absorption loss for a 10-mil thickness at this frequency is calculated as 12.9 decibels. From table 5-4, the reflection loss is 117 decibels. Since the absorption loss is greater than 10 decibels, the re-reflection loss can be

EP 1110-3-2
31 Dec 90

ignored; or, by consulting table 5-8, a re-reflection loss can be estimated from the 100-kilohertz column as roughly +0.5 decibels. Thus, the total SE ($SE = A + R + B$) would be $12.9 + 117 + 0.5 = 130.4$ decibels. Table 5-12 shows other examples of SE calculations. If the above data do not include the parameters desired, the relationships for SE can be used (eqs 5-2 through 5-8).

5-5. Shielded enclosures.

a. Enclosure shielding effectiveness. The SE relationships and data in paragraph 5-4 assume a sinusoidal wave incident on a large (many wavelengths) plane surface. For other surface geometries, such as a shielded enclosure with sharp corners and small dimensions compared to a wavelength, the surface currents induced on the shield will not be uniform. Thus, the actual shielding provided by such enclosures will likely vary somewhat from that estimated using the SE relationships of paragraph 5-4. However, these plane-surface data provide a valid basis for enclosure designs and yield realistic approximations of the SE that can be achieved in practical enclosures.

(1) Low-carbon steel walls. Figure 5-14 shows the manufacturer's specified minimum SE for an enclosure made of low-carbon-steel walls. Note from this figure that for fairly thick enclosure walls (1/4 to 3/8 inch), the minimum magnetic field SE approaches 100 decibels, even for frequencies as low as 1 kilohertz. The enclosure SE values must be derated when penetrations and apertures (especially doors) are included if they are not designed to provide an SE equal to that of the shield.

(2) Layered sheet -steel walls. Typical commercial enclosures, which are acceptable for 60-decibel shields, are built with two thin layers of steel separated by plywood or other core material. Even with the fairly thin metal thicknesses and the penetrations and apertures needed for power, doors, and ventilation, these enclosures will provide significant attenuation levels to plane waves over the range of frequencies in the HEMP spectrum. Figure 5-15 shows the manufacturer's specified performance for a typical dual-wall, bolted-panel commercial enclosure. Even for an enclosure with two thin layers of 24-gauge steel, the enclosure is predicted to provide at most 60 decibels of attenuation down to 10 kilohertz.

(3) Mean shielding effectiveness. Laboratory experiments on new enclosures have shown that the seams of bolt-together laminated steel and wood shielded enclosures may have lower SE values than claimed by the manufacturers (ref 5-4). Figure 5-16 shows a measured mean value for three room types. These data represent the mean SE from 56 test points in each room tested. The standard deviation of the test data is relatively large; for example, data for one of the rooms had a standard deviation of 17 decibels (92 decibels = mean) at 200 kilohertz magnetic field testing. It should be noted that the shielded room data in reference 5-4 were taken after initial assembly of the enclosures. No efforts were made to determine the points of greatest leakage or to increase SE at those joints. Further, after aging, the bolt-together

construction would require maintenance which would greatly affect life-cycle cost.

b. Enclosure response to HEMP.

(1) Spherical enclosure and magnetic field. The exact calculation of a practical enclosed structure's SE when exposed to a transient rather than a sinusoidal waveform is extremely complex. The magnetic SE of an enclosure has been reasonably approximated by assuming an ideal enclosure geometry--a solid spherical shell. The total SE for this geometry has been derived and plotted in a nomograph to provide a rapid way to evaluate the HEMP magnetic field SE of a spherical shell enclosure (ref 5-5). Care must be taken in using the nomograph. For example, the nomograph implies that a very thin shield can provide good shielding against HEMP. However, this does not imply that thin shields are recommended because mechanical fabrication problems make them undesirable. It simply shows that, since a thin shield would provide reasonable SE, thicker shields would afford even better SE.

(2) Spherical enclosure and peak voltage. Following a similar approach, the peak voltage induced in a loop inside a 10-meter-radius spherical shield has been calculated. Three shield wall thickness (0.2, 1, and 5 millimeters) and three different wall materials (copper, aluminum, and steel) were used in the calculations. Table 5-13 shows the results. For all materials and thicknesses, the peak HEMP-induced voltages inside the shield are very small. These values were calculated using Faraday's Law of Magnetic Induction ($V_{\text{induced}} = BA$, where B is the time rate of magnetic flux density and A is the loop area normal to the magnetic field).

(3) Practical enclosures. The above results were obtained for an idealized spherical enclosure that had no discontinuities in its walls. Thus, the results can be seen only as approximations of the SE of practical, rectangular enclosures. However, the results do suggest that even fairly thin, solid shields will likely reduce HEMP transients to tolerable levels in ground-based facilities. It is expected that--

(a) Facility mechanical construction requirements and cost rather than HEMP shielding requirements will dictate the final type and thickness of the shield material used.

(b) The overall effectiveness of enclosure shielding will depend on shield penetration and treatment of openings rather than shield material.

5-6. Mesh and perforated type shields. Mesh screens and perforated sheets are used both in fabricating enclosures and in electromagnetic closure of apertures where ventilating air is required. Honeycomb-type panels are a form of nonsolid shield used extensively for aperture EM closure.

a. Screens and perforated metal shields. Leakage through openings (apertures) in metal shields has been studied using transmission line theory.

EP 1110-3-2
31 Dec 90

Based on these studies, the SE of mesh and perforated type shielding materials has been defined as--

$$SE_a = A_a + R_a + B_a + K_1 + K_2 + K_3 \quad (\text{eq 5-10})$$

where A_a = penetration loss for a single aperture in decibels, R_a = aperture reflection loss in decibels, B_a = correction term (in decibels) due to successive reflections, K_1 = loss term to account for the number of openings per unit square, K_2 = penetration loss correction term for penetration of the conductor at low frequencies, and K_3 = a correction term to account for closely spaced shallow holes in the material. Normally, these correction terms may be neglected.

(1) Shielding effectiveness parameters. The terms A_a , R_a , and B_a in equation 10 relate to penetration loss, reflection loss, and the re-reflection loss correction term for a single aperture. K_1 provides for multiple apertures of the same dimensions and represents the decreased SE due to multiple apertures per unit square (the "unit square" dimension unit of measure is the same as that for the aperture, i.e., inches, meters, etc.). This term applies only when the source-to-aperture distance is large compared with the aperture dimensions. K_2 is a correction term for the penetration loss (A_a) when the conductor dimensions approach the skin depth dimension, i.e., mesh wire size or conductor width between holes approaches the skin depth for the material used at the low end of the frequency spectrum of interest (10 kilohertz for HEMP). K_3 is a correction term for the penetration loss of closely spaced shallow holes. K_3 accounts for "adjacent hole coupling" between apertures since the degradation of SE for multiple, closely spaced apertures is not the linear sum of the single aperture loss over the number of apertures.

(2) Single layer wire cloth and screening calculations. Detailed expressions for the screen and perforated metal sheet SE terms are given as follows for single-layer wire cloth or screening:

$$\begin{aligned} A_a &= \text{aperture attenuation in decibels} \\ &= 27.3 D/W \text{ for rectangular apertures} \end{aligned} \quad (\text{eq 5-11})$$

$$= 32 D/d \text{ for circular apertures} \quad (\text{eq 5-12})$$

where D = depth of aperture in inches, W = dimension of a rectangular aperture in inches (measured perpendicular to the E-vector), and d = diameter of a circular aperture in inches.

$$R_a = \text{single aperture reflection loss in decibels}$$

$$= 20 \log \frac{(1+k)^2}{4k} \quad (\text{eq 5-13})$$

and B_a = single aperture correction factor for aperture reflection (small when A_a is greater than 10 decibels)

$$= 20 \log \left[1 - \frac{(k-1)^2}{(k+1)^2} \times 10^{-0.1A_a} \right] \quad (\text{eq 5-14})$$

(a) In equations 5-13 and 5-14:

k = ratio of aperture characteristic impedance to incident wave impedance, or

magnetic fields $= W/3.142r$ for rectangular apertures and (eq 5-15)

magnetic fields $= d/3.682r$ for circular apertures and (eq 5-16)

and radiated fields $= jfW \times 1.7 \times 10^{-4}$ for rectangular apertures (eq 5-17)

and radiated fields $= jfd \times 1.47 \times 10^{-4}$ for circular apertures (eq 5-18)

where f = frequency in megahertz, r = distance from signal source to shield in inches, and $j = (-1)^{0.5}$, W = largest dimension of rectangular aperture, and d = diameter of circular aperture.

K_1 = correction factor for number of openings per unit square (applies when test antennas are far from the shield compared with distance between holes in the shield)

$$= 10 \log \frac{1}{an} \quad (\text{eq 5-19})$$

where a = area of each hole in square inches and n = number of holes per square inch.

low frequencies K_2 = correction factor for penetration of the conductor at

EP 1110-3-2
31 Dec 90

$$= -20 \log \left[\left(1 + \frac{35}{2.3 p} \right) 705 \right] \quad (\text{eq 5-20})$$

where p = ratio of the wire diameter to skin depth, d :

$$d = \frac{6.61}{f} \quad \text{in centimeters, } f \text{ in hertz}$$

$$d = \frac{2.60}{f} \quad \text{in inches, } f \text{ in hertz} \quad (\text{eq 5-21})$$

K_3 = correction factor for coupling between closely spaced shallow holes

$$= 20 \log \left[\frac{1}{\tanh (A_a / 8.686)} \right] \quad (\text{eq 5-22})$$

Figure 5-18 presents these parameters in graphic form.

(b) As an example, determine the SE of a No. 22, 15-mil copper screen when it is subjected to a magnetic field from a loop source 1.75 inches away and operating at a frequency of 1 megahertz. Such a screen has 22 meshes per linear inch. The center-of-wire to center-of-wire distance is 1/22 (0.045) inch and the opening width is smaller by an amount equal to the wire meter, 0.015 inches. The depth of the aperture is assumed to be equal to the wire diameter. Thus--

$$\begin{aligned} A_a &= (27.3)D/W = (27.3) (0.015) / (0.045 - 0.015) \\ &= 13.5 \text{ decibels} \end{aligned}$$

The impedance ratio for the magnetic wave and rectangular apertures is given by--

$$\begin{aligned} k &= W/(\pi)r = (0.045 - 0.015) / [1.75(\pi)] \\ &= 0.00554 \end{aligned}$$

and the reflection term is--

$$R_a = 20 \log \left[\frac{(1 + k)^2}{4k} \right] = 33.2 \text{ decibels}$$

The multi-reflection correction term is--

$$B_a = 20 \log \left[1 - \frac{(k - 1)^2}{(k + 1)^2} \times 10^{-A_a / 10} \right]$$

$$= -0.4 \text{ decibels}$$

The correction factor for the number of openings is--

$$\begin{aligned} K_1 &= 10 \log \left(\frac{1}{an} \right) \\ &= 10 \log \frac{1}{(0.045 - 0.015)^2 (22)^2} \\ &= 3.5 \text{ decibels} \end{aligned}$$

The skin depth correction term is--

$$\begin{aligned} K_2 &= -20 \log [1 + (35/p^{2.3})] \\ p &= \frac{0.015}{2.6 \times 10^{-3}} = 5.77 \\ K_2 &= -20 \log [1 + 35/56.3] = -4.2 \text{ decibels} \end{aligned}$$

Finally, the hole-coupling correction factor is given by--

$$\begin{aligned} K &= 20 \log [1/\tanh (A_a/8.686)] \\ &= 0.8 \text{ decibels} \end{aligned}$$

The screen's SE is the sum of the six factors--

$$\begin{aligned} SE &= 13.5 + 33.2 - 0.4 + 3.5 - 4.2 + 0.8 \\ &= 46.4 \text{ decibels} \end{aligned}$$

(3) Using tables. Representative mesh and perforated sheet SE measurements are shown in tables 5-14 and 5-15. These tables provide data on a variety of material forms including meshes, perforated sheets, and cellular structures in protecting against low-impedance, high-impedance, and plane waves. Table 5-16 gives both calculated and measured values of SE for the No. 22 15-mil copper screen in the example for magnetic, plane, and electric waves for several frequencies. The SE of the screen increases with frequency for magnetic fields, declines with increasing frequency for plane waves, and is largely independent of frequency for electric fields.

(4) Shield dimensions. Screen shields usually consist of a single or double layer of copper or brass mesh of No. 16- to 22-gauge wire with openings no greater than 1/16 inch. A mesh less than 18 by 18 (wires to the inch)

EP 1110-3-2
31 Dec 90

should not be used. The mesh wire diameter should be a minimum of 0.025 inch (No. 22 AWG). If more than a nominal 50 decibels of attenuation is required, the screen should have holes no larger than those in a 22-by-22 mesh made of 15-mil copper wires.

(5) Galvanized hardware cloth. A mesh construction in which individual strands are permanently joined at points of intersection by a fusing process that provides good, fixed electrical contact affords strong SE and is not degraded by wires oxidizing and eliminating electrical contact. An example of this type of construction is galvanized hardware cloth. These screens are very effective for shielding against electric (high-impedance) fields at low frequencies because the losses will be mainly caused by reflection. Screens of this type are commercially available for EM closing of open apertures to allow for ventilation. They usually are not used to construct enclosures. Installation for aperture control is done by connecting a screen around the edge of the opening.

b. Honeycomb. Honeycomb panels are formed as a series of cylindrical, rectangular, or hexagonal tubular openings. Each opening acts as a waveguide-below-cutoff attenuator. The depth of the aperture determines the amount of attenuation realized and the diameter of each opening determines the cutoff frequency. For a rectangular waveguide attenuator, the cutoff frequency, f_o , is given by (ref 5-6)--

$$f_o = \frac{6920}{W} \text{ megahertz.} \quad (\text{eq 5-23})$$

For a circular guide--

$$f_o = \frac{5900}{W} \text{ megahertz} \quad (\text{eq 5-24})$$

where f_o = cutoff frequency for the dominant mode in megahertz and W = inside diameter of a circular waveguide in inches, or the greatest dimension of a rectangular waveguide in inches.

(1) Attenuation. At any frequency, f_a , the waveguide attenuation is a function of the ratio L/W , where L is the depth of the guide. For f_a much less than cutoff (that is, $f_a < 0.1f_c$), the attenuation in decibels per inch for cylindrical waveguides is approximated by the relation--

$$a = \frac{32}{W} \quad (\text{eq 5-25})$$

where W is in inches. For rectangular waveguides, the attenuation in decibels per inch is--

$$a = \frac{27.3}{W} \quad (\text{eq 5-26})$$

Equations 5-23 through 5-26 are valid for air-filled waveguides with length-to-width or length-to-diameter ratios of three or more.

(2) Rectangular and circular waveguides. The attenuation of a waveguide for frequencies below cutoff is shown in figure 5-22 for a rectangular waveguide and in figure 5-23 for a circular waveguide, both for an L/W ratio of 1. For ratios other than 1, the value in decibels obtained from the curve must be multiplied by L/W to obtain the correct attenuation value. For example, an SE of over 100 decibels can be obtained at 10,000 megahertz with a 0.25-inch-diameter tube, 1 inch long, or a 1/2-inch-diameter tube, 2.25 inches long.

(3) Maintaining airflow through honeycomb. Metal honeycomb is usually used to provide EM closure of open apertures required for ventilation and/or cooling, although screening and perforated metal sheets can also be used. These materials provide for air flow through an enclosure while maintaining the SE. All such materials present an impedance to airflow compared with an open aperture of the same dimensions. Of the types listed, honeycomb provides the maximum EM attenuation with the least reduction in air flow. Figures 5-24 and 5-25 compare air impedance properties for honeycomb and screen materials. If these types of materials are used, it is necessary to increase the overall aperture dimensions to achieve the same air flow as with an unprotected aperture.

5-7. Layered shields. When shielding is mainly by reflection loss (high frequencies), two or more layers of metal, separated by dielectric materials and yielding multiple reflections, will provide greater shielding than a single sheet of the same material and thickness. Separation of the two metal layers is necessary to provide additional discontinuous reflection surfaces. When two metallic sheets of the same material and thickness are separated by an air space, the penetration and reflection losses increase but are not double the value (in decibels) of a single sheet. Benefits of layered shielding also have been noted with magnetic sheet material. With high permeability metal, two layers of material increase the SE by roughly 15 decibels compared with a single layer over a fairly broad frequency range.

5-8. Reinforcement steel (rebar).

a. Concepts. Many buildings are built with walls reinforced with steel bars or wire mesh. This structural arrangement will provide limited shielding to low-frequency fields, but not to high-frequency fields, if the conductors are welded or otherwise electrically bonded together at all joints and intersections to form many continuous conducting loops or paths (mesh structure). Further, the rebar structure must be continuous around the volume to be shielded. The SE obtained is not cost-effective. If rebars are

EP 1110-3-2
31 Dec 90

intersection-welded only to provide shielding, the other approaches discussed would be more cost-effective. If the rebars must be intersection-welded for structural support, limited shielding is obtained at no additional cost. In this case, the SE obtained is proportional to the magnitude of circulating currents induced by the impinging EM field in and about the four walls, floor, and ceiling of the structure. The degree of shielding depends on the size and shape of the volume to be shielded, the diameter of the bars and spacing (the distance between bar centers which determines aperture size), the electrical and magnetic properties of the reinforcement steel materials (conductivity and relative permeability), and the frequency of the incident wave due to the aperture size.

(1) Electrical assumptions. It is much simpler to calculate shielding obtained using reinforcement steel if electrical conductivity, permeability, diameter, and spacings are within a practical range associated with reinforcement steel (rebar) used for normal construction. The following discussion assumes a conductivity of $g_r = 6.5 \times 10^6$ mho per meter and a permeability of $\mu_r = 50$ which is typical of rebar. The frequency assumed in these calculations was 10 kilohertz.

(2) Reinforcement dimensions. The bars' diameter and spacing depend on the building's structural design. Typical bar diameters chosen for the following calculations range from 20 to 60 millimeters and spacings range from 9 to over 50 centimeters (table 5-17 lists some typical rebar sizes). Bar diameters can vary 10 percent from nominal values without seriously affecting the accuracy of shielding data calculations.

(3) Magnetic attenuation. The family of curves shown in figure 5-27 demonstrates the magnetic attenuation for an enclosure which is 5 meters high. The curves represent the center area attenuation. The other dimensions vary over a 5-to-1 range. Figure 5-28 shows the same information for a 10-meter enclosure height. Bar diameters are 4.3 centimeters with a spacing of 35 centimeters on centers. Provisions for determining decibel correction factors to these figures for other bar diameters and spacings are as follows, based on room proportions:

- (a) Height of 10 meters or greater--use curves for 10 meters.
- (b) Height between 5 and 10 meters--use curves for 5 meters.
- (c) For variations in width dimension (J)--use curve equal to or just less than the required value.

(4) Double-course reinforcement. The room dimensions, bar spacing, and diameters shown in figure 5-27 are typical and cover most cases found in practice. The curves in figure 5-28 can also be applied to double-course reinforcing steel construction if the single-course spacings are halved when determining attenuation corrections for double-course bar construction. In

addition, table 5-17 lists examples of corrections to be used in various cases.

(5) Degradation of shielding effectiveness. The attenuation values obtained from figures 5-27 and 5-28 (with corrections as necessary according to fig 5-29) can be obtained at the center of the room. Less shielding will be available near the edges of the room. Figure 5-30 indicates that SE can be expected to degrade by 10 decibels at a distance of about 10 centimeters from the wall. The degradation curve is valid for room heights between 7.5 and 12.5 meters and lengths ranging from 12.5 to 100 meters. It is also suited for use with solid steel plate and wire mesh constructions that have the same type of SE degradation away from the central area.

(6) Sample calculations. The sample calculations in paragraphs b and c below show how the various curves are used. To determine the center area attenuation and the attenuation near a wall for single-course and double-course reinforcement bar-type construction, assume $H = 6$ meters, $J = 10$ meters, $L = 50$ meters, reinforcing steel diameter = 3.5 centimeters plus 10 percent, and reinforcement steel spacing = 37 centimeters, center to center.

b. Single-course reinforcing steel construction. Since $H = 6$ meters, use the curve for $H = 5$ meters (fig 5-27). For $J = 10$ meters and $L = 50$ meters, the attenuation is 24.5 decibels. For 3.5-centimeter-diameter rebars on 37-centimeter centers, use the correction factor of minus 2 decibels from figure 5-29. Thus, the center area attenuation is $24.5 - 2 = 22.5$ decibels. This will be the attenuation in the room beyond 2 meters of the shielding rebars. Assume that the bars used are near the outside of the wall so that a 45-centimeter wall thickness is between the rebar and an equipment cabinet. The attenuation at this point (from fig 5-28) would be $22.5 - 3.5 = 19$ decibels.

c. Double-course reinforcing steel construction. For this calculation, consider that center area attenuation = 24.5 decibels (from fig 5-27), 37-centimeter spacing, 3.5-centimeter diameter (read from curve F, fig 5-29); 19-centimeter spacing (for double steel) = 9.2 decibels, and the total attenuation = 33.7 decibels for double rebars. For equipment against the wall, assume the inner bars are 10 centimeters from an inside wall of the room. Figure 5-28 gives -10 decibels for this distance. The net shielding at this point is $33.7 - 10 = 23.7$ decibels.

(1) Effect of bar size and spacing. Figure 5-31 shows the low-frequency SE for welded reinforcement steel as a function of frequency for different mesh sizes and reinforcement steel diameters. When compared with the data in figures 5-27 and 5-28, this figure suggests that decreasing the space between bars and increasing the bar diameter will increase the SE of reinforcement steel. Generally, decreasing the space between bars increases the attenuation a few decibels, whereas increasing it does the opposite. Increasing the diameter of the bars also increases the attenuation afforded by the walls, whereas decreasing the reinforcement bar diameter lowers the protection.

EP 1110-3-2
31 Dec 90

(2) Welding intersections and splices. To increase the reinforcement bar's SE, all intersections must be welded to insure minimum electrical resistance at the joints. Other mechanical tying or clamping should follow standard construction practices to insure mechanical strength, but this should not replace welding for electrical purposes. Figure 5-32 shows typical welding practice for construction steel reinforcement bars. Welding can reduce the rebar's strength to some degree. When possible, a continuous electrical loop must enclose the whole wall, with all rebars welded firmly to the loop at crossings and terminations. Unavoidable splices should be welded over a length at least three times the bars' diameter. Interruptions in the bars, as at vents or doors, should be welded to heavy frames as figure 5-33 shows.

(3) Welding at corners. Reinforcement steel can be formed into continuous loops welded together at the building corners (ref 5-7). For two layers of 10-millimeter reinforcement steel bars welded to 16-millimeter bars at the corners, a 15-millimeter grid gave 35 and 39 decibels at 150 kilohertz and 1 megahertz, respectively. A 25-millimeter grid gave 26 and 27 decibels at 150 kilohertz and 1 megahertz, respectively. When the openings become an appreciable part of a wavelength, the SE decreases.

(4) Welded wire fabric. Welded wire fabric embedded in the walls of a room or building can provide attenuation if individual fabric wires are joined to form a continuous electrical loop around the perimeter of the area to be shielded. At each seam where the mesh meets, each wire must be connected by a continuous strip.

(5) Attenuation from welded wire fabric. The attenuation at the center of the enclosed room for welded wire fabric can be obtained from the same set of curves used to find values for reinforcing steel bars. An attenuation correction factor (increment) will be needed (table 5-18).

5-9. Earth cover electromagnetic wave attenuation.

a. Absorption loss. In the environment outside a facility, nonmetallic materials such as soil and rock can contribute to shielding, especially at higher frequencies (i.e., above 10 megahertz). This depends on the material's conductivity, permittivity, and permeability. Since these materials are poor conductors, their conductivity is low and is influenced strongly by water content. Typically, the conductivity in mhos per meter over the frequency range in kilohertz to megahertz varies from 3×10^{-4} to 8×10^{-3} at 1 percent water content, from 8×10^{-3} to 3×10^{-2} at 10 percent water content, and from 10^{-1} to 1.5×10^{-1} at 50 percent water content; it is 2×10^{-1} at 100 percent water content (ref 5-5). Table 5-25 shows the electrical conductivity of various soils and rocks. Soils and rocks have a wide range of water content, making their electrical conductivities vary. Table 5-20 lists the absorption loss (A) for soils with 1, 10, and 50 percent water content at selected frequencies. Even for a soil water content of 50 percent, the absorption loss

becomes significant only at frequencies higher than about 10 megahertz. Thus absorption loss in soil will be effective as a shield only at the higher HEMP frequencies (above 10 megahertz).

b. Reflection loss from soils. Determining the reflection loss from soils is a complex problem due to the inherent inhomogeneity of soil and rock strata. Typically, soil impedances are relatively high, and thus, for the plane wave electromagnetic fields from HEMP, reflection losses will be low. For conservative designs, the facility designer should assume no reflection loss for the soil and rock overburdens of buried facilities.

5-10. Shield joints and seams.

a. Shield fabrication. An ideal shielded enclosure would be one of seamless construction with no openings or discontinuities. However, practical enclosures must have seams to facilitate construction. Each seam represents a potential discontinuity in the shield, and the enclosure SE may be degraded if the seams are not designed properly. Optimal seam design through the use of permanent bonds (welding, brazing) makes joints continuous. For enclosures used in an inside environment, satisfactory results may be obtained with closely spaced rivets or spot welding or with RF gaskets if care is taken when preparing the mating surfaces and installing the fasteners. However, these techniques tend to form fasteners that degrade over time, so that welding probably provides the most cost-effective method in terms of life-cycle cost. Bolted or riveted shields are not recommended for use on facility exteriors. Shields must have structural support to prevent possible degradation of the seam by distortions. Free-standing shielded enclosures are available commercially and are suitable for use as individual enclosures inside a facility for equipment calibration and low-level shielding (up to 50 decibels). For an overall shield lining, the facility's structural design must incorporate and support the shield.

b. Seam bonding. Seams or openings in enclosure or compartment walls, with proper bonding, will provide a low impedance to RF currents flowing across the seam. For high-quality shielding (60 decibels and higher), mating surfaces of metallic members in an enclosure should be bonded together by welding, brazing, sweating, swagging, or other metal flow methods. To ensure that the bonding techniques are suitable and done correctly, design principles in paragraph 5-16 should be used. The most desirable bond is achieved through a continuous butt or lap weld.

(1) Metal thickness. For welded joints, the metal chosen must be thick enough for easy welding and it must not buckle under the welding heat. Welds in steel at butt joints should have full penetration, with the minimum thickness equivalent to 3-millimeter steel as shown in figure 5-34. For a facility shield, the recommended minimum thickness is usually 14 gauge. Metal-inert gas (MIG) welding should be used to ensure good electrical conductivity. Fillers used in welding should have conductivity and permeability equal to or better than those of the shield material.

EP 1110-3-2
31 Dec 90

(2) Mating surfaces. All mating surfaces must be cleaned before welding. Also, all protective coatings with a conductivity less than that of the metals being bonded must be removed from contact areas of the two mating surfaces before the bond connection is made. Mating surfaces should be bonded immediately after protective coatings are removed to prevent oxidation. Refinishing after bonding is acceptable from the standpoint of SE, but can lead to problems in detecting faults by visual inspection. Seam backup plates should be used for thin sheets (16 to 12 gauge). The plates must be held in place firmly before welding to prevent buckling.

(3) Soldering. Soldering is an acceptable way to join solid metal sheets for WBCs and other areas sensitive to the high temperatures of welding. Care must be taken during soldering because joint expansion can crack the connection. Also, fluxes in the solder process can cause corrosion later, which will degrade the bond. If soldering is the only suitable way to join screens, use only nonreactive or noncorrosive inorganic flux for electrical bonding.

c. Mechanical joining (shielding reqts below 60 decibels).

(1) Mechanical seams. Rather than welding or soldering seams, it is possible to join them mechanically. Bolts, screws, rivets, and various types of clamp and slide fasteners have been used for this purpose. The same general requirements for clean, intimate contact of mating surfaces and minimized electrolytic (cathodic) effects apply to temporary bonds. Positive locking mechanisms should be used to ensure consistent contact pressure over an extended time. Figure 5-35 shows some typical overlapping, bolted joints, all of which are acceptable when a 60-decibel or less SE is required. Pressures of 25 kilograms per linear centimeter are recommended for joint overlaps of 4 to 100 centimeters to maintain metal-to-metal contact (ref 5-7). This contact can be improved by galvanizing steel panels. For thin panels, bolts should be close enough to ensure uniform panel edge contact, with stiffeners running along the joint to spread forces and maintain high pressure between the bolts and to prevent buckling. If these methods are used for exterior shields exposed to weather, the seam must be weather-sealed to prevent corrosion.

(a) Bolts, nuts, screws, and washers that must be made of material different from the surfaces to be bonded should be higher in the electromotive series (table 5-21) than the surfaces. This measure ensures that material migration will erode only replaceable components.

(b) A critical factor in nonwelded mechanical joints is the linear spacing of the fasteners or spot welds. The gaps between fasteners are slots in the shield that leak incident energy. The data in figure 5-36 show that, for fastener spacings less than 65 centimeters and frequencies less than 100 megahertz, the coupled HEMP interference increases proportionally with frequency. Figure 5-37 shows the sensitivity of this parameter for a 1.27-

centimeter aluminum lap joint at 200 megahertz. Bolted connections require periodic maintenance (tightening). They are acceptable for removable access panels.

(2) Seams with gaskets. The SE of direct metal matings used as temporary bonds can be improved greatly using flexible, resilient metallic gaskets between shielding surfaces to be joined. Clean metal-to-metal mating surfaces and good pressure contact are required. ("Good" pressure contact is roughly 25 to 30 percent compression; however, the gasket manufacturer's recommendations should be followed for a specific gasket.)

(a) The major material requirements for RF gaskets are compatibility with the mating surfaces, corrosion resistance, suitable electric properties, resilience (especially when repeated compression and decompression of the gasket is expected), mechanical wear, and ability to form into the desired surface.

(b) Based on electrical properties and corrosion resistance, it has been found that the single most important EMI gasket parameter is the coating material applied to the gasket base metal (ref 5-8). An often preferred coating material is tin, applied thick enough to withstand nominal wear without erosion to the base metal. An excellent guide to the selection of EMI gasket coating or finish material as a function of gasket type and gasket base metal is ARP-1481, Corrosion Control and Electrical Conductivity in Enclosure Design (ref 5-9). This guide should be consulted before making final EMI gasket selection.

(c) For seams that require moisture/pressure sealing as well as RF shielding (such as an exterior door), combination rubber-metal seals are available. These include metal mesh bonded to neoprene or silicone, aluminum screen impregnated with neoprene, convoluted wires in silicone, conductive adhesives and sealants, and conductive rubber. Table 5-22 summarizes the advantages and drawbacks of these gaskets as well as the nonsealing type.

(d) Silver-filled silicone rubber gaskets can be obtained in sheet, die-cut, molded, or extruded form. The most popular and economical of these types is the extrusion. These gaskets are usually used in applications for which both electromagnetic and weather sealing are required. Figure 5-38 shows typical extruded shapes and gives recommended deflection limits for various shapes and sizes. Earlier comments on thickness, shape, and mounting methods for wire mesh gaskets also apply to conductive rubber gaskets.

(e) SE of silver-filled (or silver-plated, copper-filled) silicone is acceptable for low-performance (less than 60 decibels) enclosures between 15 kilohertz and 10 gigahertz. Best results are achieved with molded or extruded cross sections held in grooves.

(f) Metal mesh gaskets can be held in place by sidewall friction, soldering, adhesive, or by positioning in a slot or on a shoulder. Soldering

EP 1110-3-2
31 Dec 90

must be controlled carefully to prevent solder from soaking into the gasket and destroying gasket resiliency. Adhesives (especially nonconductive ones) should not be used on gasket surfaces that mate for RF shielding purposes-- auxiliary tabs should be used. The necessary gasket thickness depends on the unevenness of the joint to be sealed, gasket compressibility, and the force available. The shape required depends on the particular use as well as the space available, the way the gasket is held in place, and the same parameters that affect gasket thickness. Figure 5-39 shows typical uses and mounting methods for gaskets.

(g) Typical gasket pressures for obtaining effective seals range from 5 to 100 psi. The specific pressure needed will depend on the type of gasket used, the thickness of metal to be joined, and the spacing of bolts or screws in the joint. Too little pressure will not preserve good electrical contact. Too much pressure, combined with lack of stiffness of mating members and too much spacing between bolts, can cause the shield to deform as shown in figure 5-40. Shield imperfections also can damage gaskets and should be corrected before installation is completed.

(h) The most demanding use for EMI gasket materials in shielded facility construction is as gasketed seams around shielded doors and access panels that must be opened periodically. It has been shown that the most severe shielding degradation occurs around these seams for all EMI gasket materials (ref 5-8). The shielding loss at these places is not rectified simply by using the best EMI gasket, but involves geometric design and materials selection (including surface coatings) of the gasket mating surfaces (for example, the door channel) along with regular maintenance. A discussion of these factors, along with recommended door channel design, is in reference 5-8. Figures 5-41 through 5-43 show some door channel designs that include many such "optimal" features using three different types of EMI gaskets. Even with these designs, however, periodic surface/gasket cleaning, lubrication, or both would be required to maintain a reliable shield.

(3) Gasket selection--summary. The recommended gasketing for 100-decibel shielded doors and access panels can be summarized as follows:

- (a) Shielded doors. The best choices (for HEMP) are (ref 5-8)--
- Fingerstock, double-row in slot.
 - Knife-edge closure.

Note: if a higher level of shielding is required than that attainable with the knife-edge/fingerstock door, then the only choice is the air-expansible door which has knurled or thermally sprayed mating surfaces. These doors are expensive and require much more space and maintenance than the knife-edge door.

- (b) Access panels. For these panels, use--

EP 1110-3-2
31 Dec 90

- Preformed or fitted mesh gaskets.
- Monel or Ferrex material (fig 5-39).
- Manufacturer's recommended closure pressure.

5-11. Internal cable and connectors.

a. Shielding effectiveness. Cables and conduit for electrical wiring are a primary source of damaging HEMP-induced transients. Thus, if proper shielding methods are not used, the transmitted HEMP transient signal can penetrate zone boundaries to sensitive electronics, causing upset or damage. Shielding prevents the HEMP coupling by internal conductors.

(1) Analysis methods. In cable shield analysis, two methods often are used to describe internal cable conductor isolation from external shield currents. The first is the SE of the cable, with SE given as the ratio in decibels of the external shield current to the internally induced conductor current versus frequency. The other method used to describe external shield current isolation is surface transfer impedance, in which transfer impedance is related to the voltage drop per unit length along a cable due to the current flowing on the shield.

(2) Transfer impedance. SE can be related to surface transfer impedance if the center conductor's total resistance and the circuit load are known. This relationship can be expressed as--

$$Z_t \text{ (decibels)} = 20 \log R_L - SE \quad (L \ll \text{wavelength}) \quad (\text{eq 5-27})$$

where the units are in decibels referenced to 1 ohm and L is the length of the shield. This relationship shows that transfer impedance is inversely proportional to SE. Figure 5-44 shows this relationship for a braided coaxial cable. In this case, $R_L = 100$ and $Z_0 = 50$ ohms where Z_0 is the line's characteristic impedance.

(3) Cable length. The relationship between SE and length can be expressed as--

$$SE = 20 \log (L_1/L_2) \quad (\text{eq 5-28})$$

where SE is a decrease or increase that results from increasing or decreasing the cable length. L_1 is the original length, and L_2 is the new length (refs 5-10 through 5-12). The surface transfer impedances of solid-tubular shields, single- and multilayer braided coaxial cable, tape-wound high-permeability communications cable, and connectors have been determined analytically and experimentally. These analyses use transmission line models and involve the determination of current induced on the cable center conductor by diffusion through a solid shield and by field penetration through apertures. Also, the

EP 1110-3-2
31 Dec 90

voltage drop along the shield as a result of series resistance at interconnection points, which induces currents in the center conductor, has been found through experiments.

(4) Cable shielding methods. The most common methods of shielding cables are: braid, spirally wound shields of high permeability materials, rigid conduit, and flexible conduit. Shielded cables on the market include shielded single conductor, shielded multiconductor, shield-twisted pair, and coaxial. Cables are also available with single and multiple shields in many different forms and with a variety of physical properties.

b. Braided cable. A braid of woven or perforated metal fabric is used for cable shielding when the shield cannot be made of solid material. Figure 5-45 shows a braided wire coaxial cable. Advantages are flexibility, light weight (single shield only), and ease of cable termination. However, for radiated fields, the SE of woven or braided materials decreases with increasing frequency because of field penetration through the braid apertures. SE increases with the density of the weave or number of insulated shield layers by a reduction of the current diffusion component in the shield model. Figure 5-46 shows the relative SE of single-, double-, and triple-braided cables as a function of frequency. Reference 5-13 gives additional information on double and triple shields.

c. Tape-wound shield. Commercial power cables have center conductors wrapped with lossy materials. Figure 5-47 shows two typical cable designs. The lossy wrapping consists of a high-permeability material such as silicon iron tape. As the HEMP transient propagates along the shield, high-frequency components of the pulse are attenuated. Figure 5-48 shows the attenuation versus frequency for a typical lossy-wrapped shield. Tape-wound shields have use when shield flexibility and low cost are desired. Because of the poor SE of typical single-layer wrapped cable, an outer layer of braid often is incorporated into the cable design. Tape-wound shields have been analyzed (ref 5-13) and have been modeled as a solenoid wound about internal conductors. For very large shield currents, arcing between turns can occur, resulting in greater SE. However, the arcing itself may be undesirable for other EMI-related reasons.

d. Twisted-pair cable. To improve the common-mode rejection and SE of a signal transmission line, twisted-pair and shielded-twisted-pair cables often are used. Common-mode coupling is defined as occurring when the signal is induced between the shield and either or both interior conductors of a pair. Figure 5-49 shows the induction loop areas formed in twisted-pair cables. With a time-varying uniform magnetic field impinging radially on the twisted-pair cable, the currents induced in adjacent loops approximately cancel. The currents do not completely cancel because the induction loop area in the direction of the magnetic field is less than one twist of the cable pair (ref 5-10). Because of the small loop areas formed by the cable, the coupling usually is small.

EP 1110-3-2
31 Dec 90

(1) Using twisted pairs. With a shielded-twisted pair, common-mode coupling due to external fields is greatly reduced and spurious signal pickup can be almost eliminated on signal lines. For maximum benefit from shielded-twisted pairs, they should be used in conjunction with proper grounding, bonding, and common-mode rejection (balanced lines) methods.

(2) Shield termination. Figure 5-50 shows experimental results of the effects of improper shield termination on the SE of shielded-twisted pairs (ref 5-14). In this experiment, shield terminations at the receiving end were varied and the shield was terminated in an RF connector at the source end. Measurements were made over the band of 100 kilohertz to 50 megahertz. The figure shows five cases. In the first four, only the common-mode current was measured. In case 5, the differential-mode current for a balanced configuration was measured. The differential mode is defined as signal injection into the wire pair of opposite polarity. The figure shows that the balanced configuration offers more attenuation up to about 5 megahertz. At high frequencies, it is hard to balance a circuit. At low frequencies, a twisted pair in a balanced configuration with an unterminated shield offers more shielding than any of the unbalanced types with a properly terminated shield. The worst performance was seen in an unbalanced load with no shield termination (case 1). In this case, use of a shielded-twisted pair provided no advantage over a single wire, except for electrostatic protection. For HEMP protection, the shielded-twisted pair in a balanced transmission line configuration is preferred (case 4). The shield can be conduit, braid, or tape-wound. Conduit is recommended if the cable does not have to be flexible or removable. If it does, braid is preferred over tape-wound cabling.

e. Cable connectors. EM energy leakage through the outer shell of a cable connector can result from an improper connection between the connector plug and receptacle. The cable connector can be viewed as part of the cable shield and may contain cracks, slits, or lossy contacts through which EM energy can pass. In a transmission line model of the cable and connector, the connector can be considered a voltage source that drives the core-to-shield transmission line. Terms that enter into the analysis are a series IR drop due to lossy contacts and a magnetic field component due to field penetration through slits and cracks. Both components can be significant, but one or the other usually dominates (refs 5-10 and 5-13).

(1) Transfer impedance. The transfer impedance, Z_T , can be expressed as--

$$Z_T = R_O + j\omega M_{12} \quad (\text{eq 5-29})$$

where R_O is the resistance measured across the connector, j is $(-1)^{0.5}$, ω is radian frequency, and M_{12} is the mutual inductance between the external shield circuit and the cable's internal conductors. The transfer impedance can be measured by passing a current through a cable sample that contains the connector and by measuring the open-circuit voltage induced on the conductors inside the shield (ref 5-13).

EP 1110-3-2
31 Dec 70

(2) Common connectors. Figure 5-51 shows the construction of a few common connectors used in HEMP protection. These connectors are designated N, SMA, and TNC. All have threaded connections and meet the requirements of MIL-C-39012 (ref 5-15). Reference 5-13 presents typical values of R_0 and M_{12} for several cable connectors. These parameters were obtained experimentally using a triaxial test method. (See chapter 6.) Anodized connectors must not be used because of the very high R_0 term. Also, R_0 and M_{12} for type N connectors were not measurable, indicating high SE.

(3) Connector materials and finishes. Cable connector SE strongly depends on the connector material, whether it is a threaded or bayonet type, the tightening torque on threaded connectors, and whether spring fingers and shielded gaskets are used. For example, figure 5-52 shows the contact resistance of two aluminum surfaces with various platings and coatings. Figure 5-53 shows the SE of a connector with different finishes. SE values for all finishes are about the same except for anodized aluminum, which meets most environmental specifications but suffers degraded SE (ref 5-16).

(4) Threaded connectors. As discussed earlier, threaded connectors are preferred for use in HEMP protection because of higher SE. For threaded contacts, SE increases with higher tightening torque, especially with vibration, as figure 5-54 shows.

(5) Bayonet connectors. Bayonet connector SE can be increased by using peripheral spring fingers in the connector shell. Figure 5-55 shows the improvements in SE from adding spring fingers for both bayonet and threaded connectors.

(6) Using gaskets. Using gaskets between interfaces also increases connector SE. Figure 5-56 shows the improvements when a woven-wire mesh gasket is used. Metalized gaskets (woven wire and rubber) can also be used (ref 5-16).

5-12. Conduit and conduit connections.

a. Solid conduit. Solid conduit (or any solid metal shield) provides the highest SE since there are no apertures. The SE of conduit is maximized by using large-diameter, thick-walled tubing to reduce the diffusion component. Methods for determining the conduit SE (transfer impedance) experimentally are described in chapter 6. The transfer impedance also can be determined analytically. The tubular shield consists of a metal tube of uniform cross section and wall thickness. Coupling through the shield can occur only by diffusion of EM fields through the walls of the tube. The transfer impedance of thin-walled tubes such as this is (ref 5-13)--

EP 1110-3-2
31 Dec 90

$$Z_T = \left[\frac{1}{2(\pi)asT} \right] \left[\frac{(1-j) T/d}{\sinh(1+j) T/d} \right] \quad (\text{eq 5-30})$$

where a is the radius of the shield, s is the shield conductivity, d is the skin depth in the shield, T is its wall thickness. The d value is calculated by--

$$d = \frac{1}{(\pi)fu} \quad (\text{eq 5-31})$$

where u is the permeability and f is the frequency. It is assumed that the wall thickness T is small compared with the radius of the tube and that the radius is small compared with the smallest wavelength of interest. It is also assumed that the shield is made of a good conducting material (metal) so that the displacement current in the shield material is negligible compared with the conduction current. At low frequencies, such that $T/d \ll 1$, the magnitude of the transfer impedance is (ref 5-13)--

$$|Z_T| = \frac{1}{2(\pi)asT} = R_O \left(\frac{T}{d} \ll 1 \right) \quad (\text{eq 5-32})$$

where R_O is the direct current resistance of the tube per unit length. At high frequencies, such that $|T/d| \gg 1$, $\sinh(1-j)T/d$ approaches the value $1/2 \exp(1+j)T/d$, and the magnitude of the transfer impedance at high frequencies is--

$$|Z_T| = 2 e^{-T/d} R_{hf}, \quad \left(\frac{T}{d} \gg 1 \right) \quad (\text{eq 5-33})$$

where $R_{hf} = 1/[2(\pi)ads]$. That is, R_{hf} is the resistance of a sheet 1 meter long, $2(\pi)a$ wide, and d thick, with conductivity s . The phase of the transfer impedance at high frequencies is--

$$\text{phase} = -\frac{T}{d} - \frac{(\pi)}{4}, \quad \left(\frac{T}{d} \gg 1 \right) \quad (\text{eq 5-34})$$

Figure 5-57 is a plot of the magnitude and phase of the transfer impedance (normalized to the low-frequency value R_O) for a tubular shield. The asymptotic approximations for the magnitude and phase are also indicated in figure 5-57. As can be seen from equation 5-33 and figure 5-57, the magnitude of the transfer impedance decreases very rapidly as T/d increases above unity, so that very little of the high-frequency spectrum is permitted to penetrate to the interior of the shield. The transfer impedance and values of R_O and f_d (the frequency at which $T/d = 1$) are given in figure 5-58 for trade sizes of rigid steel conduit (refs 5-13, 5-17, and 5-18).

(1) Coupling mechanism. The main HEMP coupling mechanism for conduit is leakage at conduit interconnection points. HEMP coupling occurs as a

EP 1110-3-2
31 Dec 90

result of field penetration through apertures at joints (cracks in welded sections) and as a result of voltage drops across resistive interconnects (rusted threads of a conduit coupler).

(2) Connectors. Conduit sections can be connected by welding or by couplers and unions. Welding conduit sections forms a continuous shield. However, leakage can occur at cracks in the weld or with high-resistance welds.

(3) Flaw impedance. A conduit coupling can provide SE as high as the conduit itself if installed properly. The most important factor affecting leakage through joints is the quality of electrical contact between the joints' mating surfaces. Figure 5-59 is a plot of flaw impedance versus frequency for a taper-threaded, wrench-tightened conduit coupling. Below about 10 megahertz, the flaw impedance is nearly resistive and independent of frequency. This implies that the wave shape of an induced voltage is nearly identical to the waveform of the exciting current, provided the maximum frequency of the incident waveform is less than 10 megahertz.

(4) Coupler threads. Experiments have shown that conduits with couplings that have clean, unrusted threads can have shielding almost equal to that of continuous (welded) conduit if properly torqued (ref 5-18). If the threads are rusty before assembly, shielding degrades substantially; thus, careful cleaning of the threads is necessary before assembly. From a shielding standpoint, standard conduit couplings are inferior to line pipe couplings which have tapered threads. (Most couplings are straight-threaded.) The coupling joint's d.c. resistance indicates thread quality, but does not account for possible apertures. Applying silver- or copper-loaded conductive caulking compounds to the threads before assembly has proven advantageous for short-term applications if the threads are clean and properly torqued. However, these caulking compounds can cause severe corrosion due to dissimilar metals contact and are therefore not recommended.

(5) Leakage at threads. Leakage at threads (couplings between conduit sections and connections between conduits and conduit hardware) usually results from poor assembly or corrosion. Joined sections must be rust-free, aligned properly, and adequately torqued to provide high HEMP shielding effectiveness. Factory-cut threads should be specified to be zinc-plated and, as such, require no coatings. Field-cut threads should be coated with a primer (e.g., red lead or zinc-rich) to prevent rust.

(6) Diffusion current. A secondary HEMP coupling mechanism for conduit is the diffusion current (i.e., the penetrating current related to skin effect). Energy coupling by this mechanism has a much slower risetime and longer duration than leakage current. The magnitude of the diffusion current response of cables within conduits can reach disruptive levels for thin-walled conduit. If the conduit runs are long, the conduit-induced currents and circuit impedances are high. Figure 5-60 shows a diffusion current response determined experimentally for a 2.5-centimeter, rigid-walled steel conduit,

EP 1110-3-2
31 Dec 90

3.3 meters long. The applied current pulse had a double exponential wave shape with less than 10 nanoseconds risetime and 4 microseconds fall (E-fold) time (refs 5-18 and 5-19). Diffusion current magnitudes can be determined from the transfer impedance calculations described previously.

b. Flexible conduit.

(1) When required. If relative movements are expected between exterior conduits and the shielded structures, flexible connections may be required at exterior walls to accommodate displacements.

(2) Metal bellows. Figures 5-61 and 5-62 show typical frequency domain flaw impedances (i.e., impedance associated with a flaw in a flexible joint) for samples of metal bellows flexible conduit. The flaw impedance contributes only to diffusion current. A comparison of the two figures shows the effect of material thickness on the frequency domain flaw impedance. The diffusion current can be reduced by placing a metal braid over the metal bellows. If the braid has good electrical contact at each end (bonded to the conduit/enclosure), it can reduce the overall direct current resistance and increase the equivalent thickness through which the fields must diffuse. The bellows prevent direct field coupling through the many small holes in the braid. Thus, for maximum HEMP hardness, flexible conduit sections should have a wire braid covering and should be made of mild steel. Continuous seam bellows must be galvanized inside and outside to prevent corrosion. Another approach is to use high-permeability stainless steel for the flexible conduit. The thin walls of the flexible conduit show magnetic saturation (due to high diffusion currents) at much lower current levels than the thicker conduit material. The penetration depth of the diffusion current is the time integral of the current pulse. This is a nonlinear effect that can, under HEMP, reduce relative magnetic permeability to unity for the ferromagnetic material, thus reducing SE for the material. Therefore, thin materials should be used sparingly.

c. Conduit unions. Explosion-proof conduit unions have flat mating surfaces, with each conduit section held together by a threaded slip ring. The two halves of the union are threaded to the conduit sections and the connection is formed by the threaded slip ring.

(1) Sources of leakage. The most important places for possible leakage at a union are the threads and the slip-ring contact. As with couplers, unions must be rust-free and properly aligned and installed to provide adequate SE. Conduit systems should be built so that unions will not have to be used to align or draw together conduit sections. The alternative to proper installation and inspection is to specify expensive, nonstandard hardware.

(2) Pulse excitation tests. Various commercial and experimental unions have been tested for their SE under pulse excitation (ref 5-18). Unions tested were: a standard 25.4-millimeter steel union; a 25.4-millimeter pressure union (liquid tight); a Crouse Hinds "Thredmaker" 25.4-millimeter

EP 1110-3-2
31 Dec 90

union; an experimental HEMP union (fig 5-63); and a 25.4-millimeter expansion union (Crouse Hinds UNFL 37).

(3) Description of unions. The pressure union is a standard plumbing fixture. The "Thredmaker" is the Crouse Hinds Company's brand name for a union that can be installed on a nonthreaded conduit. The expansion union is designed to allow for expansion and contraction of conduit and to make up for conduit cut too short. It consists of a sliding sleeve structure and an internal ground spring. The HEMP union was designed to allow relatively large angular mismatch tolerance while keeping uniform electrical contact. The ball and socket joint provide this contact for the experimental union over a wide range of angular mismatch.

(4) Conclusions about unions. The following conclusions can be drawn from the test results:

(a) The pressure union has no shielding advantages over the standard electrical union,

(b) The "Thredmaker" union and the expansion union appear to have relatively high leakage rates with normal assembly and thus are not recommended for HEMP hardening requirements,

(c) The EMP union provides at least an order of magnitude more HEMP hardness over a standard electrical union. The optimal size and shape of the spherical mating surfaces have yet to be determined.

d. Conduit fittings and junction boxes. These fixtures provide access to the wires inside conduit. Conduit fittings are devices such as condulets and unilets. Figure 5-64 shows a Type C cast-iron conduit body. The cover plates for conduit bodies often are stamped from steel about 4.2 millimeters thick and are attached by two screws, one at each end. Neither a conduit body or a junction box should be used if very large HEMP currents are expected (Zone 0) to flow on the conduit. Both may be used in protected areas, however.

(1) Sources of leakage. The HEMP hardness of the standard commercial conduit body is poor. Various covers and gaskets have been tested (ref 5-18). Leakage is mainly due to surface resistance between the cover and the fitting wall and to flux linkage through the opening left between the cover and the fitting wall. Both factors can be reduced greatly by a machined cover and a machined fit inside the fitting housing, as figure 5-65 shows. For lowest resistance contact, the mating surfaces should be flame-sprayed with tin or zinc (soft metals for which surface oxides do not form a high resistance contact in a pressure fit). Some increase in EMP/EMI hardness (especially to radiated signals) can be obtained from a wrap-around junction box cover, as figure 5-66 shows. Unfortunately, unless covers and boxes are machined separately, tolerances are such that significant aperture and resistive leakage will occur.

EP 1110-3-2
31 Dec 90

(2) RF interference gaskets. RF interference gaskets (wire mesh, conductive rubber, convoluted wire) for conduit bodies, when tested by current injection, have not improved SE much over the standard cover without a gasket (ref 5-18). In MIL-STD-285 testing, however, this type of gasket did provide significant improvement at frequencies above 100 megahertz. If gaskets are used, they must be attached carefully to standard covers to prevent deformation caused by too much torque on the screws and to insure uniform gasket compression around all edges of the cover.

(3) Effect of no cover. With no cover, the conduit body presents an aperture, allowing very high-flux leakage into the conduit with a consequent increase in induced voltage on the internal conductor.

(4) Summary. In summary, standard commercial conduit bodies and junction boxes are not HEMP-tight. These access points should therefore be eliminated in Zone 0. When they must be used, only those with carefully machined cover fittings should be considered.

5-13. Terminal protection for electrical penetrations.

a. Transient suppressors. Because of the high energy level, rapid risetime, and short duration of a HEMP, special transient suppression devices often are needed to protect sensitive components from damage and upset. The types of devices available for EMP suppression are gas-filled tube spark gaps, metal oxide varistors (MOVs), silicon avalanche suppressors (SASs), and semiconductor diodes, such as high power zeners. Transient suppressors are used to protect a.c. and d.c. power lines, signal and control leads, and antenna leads. They also prevent arcing from cable outer shields to nearby metal objects, especially where they must be routed down towers or along the facility shield's exterior surface.

(1) Spark gaps. Gas-filled tube spark gaps consist of metal electrodes hermetically sealed to a glass or ceramic body. They are filled with gas of a high insulation resistance and low dielectric loss. As the voltage across the gap increases, a point is reached at which the gas ionizes and the gap conducts, with the voltage across the gap dropping to its glow voltage. If enough current is available, the gap further ionizes and transitions to the arc region with a reduction in voltage. As the current through the gap declines, a point is reached at which the gap extinguishes and returns to its normal "off" condition.

(a) For rapidly rising transients, the point at which the spark gap fires is different than the d.c. breakdown voltage. The firing voltage is a function of the transient rate of rise for a typical spark gap.

(b) The advantages of spark gaps are their high insulation resistance, low input capacitance, insensitivity to environmental changes, and high power-handling ability. The primary drawback is their slow turn-on time, which can be overcome by coincident use of an MOV as discussed below.

EP 1110-3-2
31 Dec 90

However, in Zone 0, a spark gap can handle the HEMP transient energy without damage.

(2) Metal oxide varistors. MOVs are composed mainly of zinc oxide with small amounts of bismuth, cobalt, manganese, and other metal oxides. The body structure consists of a matrix of conductive zinc oxide grains separated by insulating grain boundaries that provide PN junction characteristics. At low voltages, the boundaries do not conduct and as the voltage across the MOV increases, the resistance decreases exponentially.

(a) MOVs have very rapid turn-on times (in the low nanosecond range) and can dissipate large amounts of energy. The clamping voltage of the MOV is a function of the current through the unit and the transient rate of rise.

(b) The advantages of MOVs are their natural bidirectional operation, rapid turn-on times, ability to clamp at low voltage levels, high power-handling ability compared with semiconductors, and ability to be molded into a wide variety of shapes and sizes for use in special-purpose transient suppression devices (for example, pin filters with MOV and ferrite material). Drawbacks are high input capacitance in the off-state, degradation over time due to environmental and repeated electrical stress, large leakage currents in the off-state, and lower power-handling ability compared with spark gaps.

(3) Silicon avalanche suppressors. These are high-power semiconductor diodes with turn-on times in the picosecond range. However, they are limited in actual operation by their lead inductance, which lowers their turn-on times to those of MOVs. Their power-handling ability is less than an MOV's, but they clamp much better and their input capacitance is about the same. SASs are available in unidirectional and bidirectional configurations and in several hybrid forms to lower the device's input capacitance. Other advantages are their low leakage current in the off-state and their long-term stability with repeated pulsing.

(4) Semiconductor diodes. Because of their low power-handling abilities, standard semiconductor diodes and zener diodes are generally not used for HEMP protection external to equipment except in special hybrid surge suppressors. Low-capacitance diodes are used to lower MOV and SAS input capacitance in the off-state. By reducing the input capacitance, the device's insertion loss is reduced at high input signal frequencies. This makes it possible to protect high-frequency circuits with EMP transient suppressors as well as filters, alone or in combination, depending on the application.

(5) Features of transient suppressors. The important features of transient suppressors are--

(a) The d.c. breakdown voltage corresponds to the suppressor firing voltage when the transient has a very slow rate of rise. A suppressor to be

used in a circuit must be chosen such that the steady-state peak a.c. or d.c. operating voltage does not exceed the d.c. breakdown voltage of the protection device.

(b) Maximum firing voltage depends on the transient rate of rise and on inductive lead effects. Devices such as spark gaps have firing voltages significantly higher than the d.c. firing voltage because of the time required to cause ionization of the gas and subsequent arcing. Devices such as MOVs and SAs have very rapid firing times, which are mainly determined by inductive lead effects.

(c) Clamp voltage is the voltage level reached after the suppressor fires. For spark gaps, it is the arc voltage and for SAs and MOVs, it is often the d.c. breakdown voltage, though it may be higher, depending on the current dissipated through the suppressor (especially for MOVs) since these devices have inherent bulk and junction resistances associated with them.

(d) For maximum current-carrying ability, the suppressor should be specified to withstand the maximum surge current. For a spark gap surge arrester, consideration must also be given to the steady-state follow current. If a spark gap is installed on an a.c. power line and if the gap fires at the beginning of the a.c. positive half-cycle, the gap will have current flowing through it until the end of the positive half-cycle. In many cases, the follow energy through the suppressor can exceed the surge energy.

(e) Maximum-energy handling capacity is the amount of power a device can handle over a certain period of time.

(f) Insertion loss in the off-state happens with all transient suppression devices in a circuit, rising as signal frequency increases. Since suppressors are placed in parallel to the circuits to be protected, it is desirable to maximize the suppressor's resistance in the off-state, but to minimize input capacitance and reduce lead inductance at high signal frequencies.

(g) Leakage current in the off-state for a transient suppressor is the current measured when less than the rated voltage is applied across the suppressor. The leakage current is very low for spark gaps and, in general, is highest for MOVs. Instead of leakage current, insulation resistance is often stated.

(h) Extinguishing characteristics are unique for suppressors such as spark gaps. When specifying spark gaps, a thorough look at the extinguishing properties such as extinguishing voltage and current is necessary.

(i) Environmental sensitivity is seen when devices, such as MOVs, degrade rapidly in environmental extremes. Degradation often is measured through changes in d.c. operating values and leakage current. Environmental

EP 1110-3-2
31 Dec 90

effects that influence suppressor operation include temperature, humidity, vibration, and atmospheric pressure.

(j) Repeated pulsing can affect all suppressors. A rapid succession of pulses can damage the suppressor because of the device's inability to handle the required amount of energy. The firing properties of some devices, such as MOVs, also change with each pulse, regardless of the time interval between pulses. In general, a device that degrades with each pulse is rated to handle a certain number of pulses in its lifetime.

(6) Installation criteria. Installation criteria for transient suppressors are--

(a) Mount suppressors in the EMP vault as close as possible to the point-of-entry (POE) panel. Minimize packaging and lead inductance by limiting the interconnecting lead lengths and using leads with a large cross section.

(b) Allow enough physical spacing (or time delay) between successive suppressors or circuits so that the initial suppressor fires properly. The required time delay can also be achieved by using a lumped element delay line. The amount of delay needed depends on initial suppressor firing time and on the response times of successive suppressors, filters, and circuits to be protected.

(c) The installation wire size must be able to withstand the surge current without being destroyed. Larger size wire also provides a lower inductance than a smaller wire of the same length. The wire should be stranded rather than solid core and should be installed to achieve a length as short as possible.

(7) Comparison of terminal protection devices. Table 5-24 compares the various types of terminal protection devices (TPDs) used for HEMP protection.

b. Filters. An electrical filter can be defined as a network of lumped or distributed constant elements (capacitors, inductors, resistors, or their equivalent) that permits signal transmission at some frequencies and impedes it at others. The passband of a filter is the frequency range in which there is little or no attenuation. The stopband is the frequency range in which attenuation is desired.

(1) Classes. Filters are divided into four basic classes based on the relative positions of the passbands and stopbands in the frequency spectrum. The four basic classes of filters are low-pass, high-pass, band-pass, and band-reject. Figure 5-71 shows the attenuation as a function of frequency for each class.

(a) A low-pass filter (fig 5-71A) passes all frequencies below its cutoff frequency (f_c) and, in theory, attenuates all frequencies above the

EP 1110-3-2
31 Dec 90

cutoff frequency. This type of filter is used very often in EMI and HEMP control. Power line filters are low-pass types that pass d.c. or a.c. power frequencies without significant power loss while attenuating signals above these frequencies. Also, low-pass filters are used on control and signal lines for which all undesired frequencies are above the desired signal frequencies.

(b) A high-pass filter (fig 5-71B) passes all frequencies above its cutoff frequency and attenuates all frequencies below the cutoff frequency. High-pass filters are used on lines for which all of the undesired frequencies are lower than the desired signal frequencies. In particular, such filters are used to remove a.c. power line frequencies from signal channels.

(c) A band-pass filter (fig 5-71C) passes all frequencies between a lower cutoff frequency (f_{c1}) and an upper cutoff frequency (f_{c2}). It attenuates all frequencies below f_{c1} and above f_{c2} . This type of filter is used when undesired frequencies are both lower and higher than the desired signal frequencies.

(d) A band-reject filter (fig 5-71D) attenuates all frequencies between a lower cutoff frequency (f_{c1}) and an upper cutoff frequency (f_{c2}). It passes all frequencies below f_{c1} and above f_{c2} . This type of filter is used when the undesired signals are within a restricted frequency range and the desired signal frequencies may be over a wide frequency range both above and below the undesired signal band.

(2) Reactive versus lossy filters. Filters are also classified by the way they attenuate. Reactive, or lossless, filters attenuate unwanted signals by reflecting energy back to the source. Absorptive, or lossy, filters attenuate unwanted signals by changing them into heat in a lossy dielectric or thin layer of resistance material.

(a) Two factors greatly influence the effectiveness of reactive- or reflective-type filters. These factors become very important when the filters are required to exhibit either passband or stopband properties over wide frequency ranges (for example, a low-pass filter that must attenuate frequencies over the range 1 to 100 megahertz). For a reflective filter to have the specified passband and stopband properties, both its input and output terminals must be terminated with the design impedance of the filter. These matched impedances must be satisfied over the whole stopband region as well as the passband region if the specified attenuation is to be realized. When the desired stopband (or passband, in the case of a high-pass or band-reject filter) covers several octaves or decades of frequency range, it is very hard (if not impossible) to maintain the matched impedances, even if they are known. In addition, for applications such as power line filtering, the source, or input, impedance is probably unknown and may vary drastically with frequency. Under these conditions, the filter's performance will likely differ from design specifications. A second factor to consider with reflective filters is that they will have spurious resonances that will

EP 1110-3-2
31 Dec 90

degrade the stopband or passband properties when the bands extend over frequency ranges of several octaves. The spurious resonances result from the stray, or parasitic, reactance associated with lumped elements filters and from the natural periodicity in transmission line filters.

(b) The drawbacks of reflective filters led to the design of lossy, or dissipative, filters that take advantage of the loss-versus-frequency properties of materials such as ferrite compounds and carbonyl iron mixes. These materials are unique, with low d.c. attenuation and good high-frequency attenuation over broad, continuous frequency ranges. Lossy filter attenuation is directly proportional to the distance the signal travels through the lossy material and is specified in terms of decibels per megahertz per unit length. An important feature of dissipative filters is that they do not have spurious passbands in the stopband region. Also, since the undesired energy is absorbed in the filter's lossy fabric, an impedance mismatch at filter input/output terminals has no major effect on attenuation. The filter becomes lossy in the frequency range at which either electric or magnetic losses, or both, become large and increase rapidly with frequency. Dissipative filters of this type must be low-pass. A major use is general-purpose power line filtering.

(c) When more rapid attenuation slopes are required, a hybrid dissipative-reflective filter can be used. With proper design, the reflective filter's sharp cutoff properties can be realized. At the same time, the filter's dissipative features will remove spurious passbands in the stopband region and reduce the impedance matching requirements.

(d) Ferrite materials often are used for dissipative filters. These materials can be molded like ceramic into tubular shapes (beads) that can be slid over wires or used for choke cores. The equivalent circuit for a ferrite bead is an inductor and resistor, as figure 5-72 shows. The advantages of ferrite beads are that they are available in a wide variety of shapes and sizes, are low-cost, and are dissipative rather than reflective. Drawbacks are that they are restricted to low-pass filter designs, are useful only in low-impedance circuits (less than a few hundred ohms), and saturate at fairly low current levels (saturation can occur in certain types for currents as low as 10 milliamperes). Ferrite beads suppress frequencies above 1 megahertz, whereas ferrite chokes may be used at frequencies as low as 20 kilohertz with special design. Ferrite beads have been used on mechanical penetrations (cables) for aircraft controls since the cable cannot be bonded to an enclosure. Additional uses would be on otherwise unprotected, internal (inside the enclosure) signal or control wires.

(e) Still another concept of lossy filtering is the filter-pin connector. In this device, the filter is built into the cable-pin assembly (figure 5-73). Each filter-pin is configured as a connector by lossy material (such as ferrite) surrounding the pin, with shunt capacitors between the pin and the connector shell. Filter-pins have been reduced to such small size that filter-pin connectors are now available with as many as 128 pins.

However, because of the limited shunt capacitance and series inductance that can be built into the pin, filters of this small type offer little attenuation below about 1 megahertz. In a 50-ohm system, the typical attenuation offered by filter-pins is about 20 decibels at 10 megahertz, up to 30 decibels at 100 megahertz.

(3) Filter uses. In the design of a shielded enclosure that is to protect circuits from a HEMP environment, any wire or cable that will be exposed to this environment and that penetrates the shielded enclosure must be filtered to prevent coupling of HEMP into the facility along conductive paths. Filters are the primary form of protection. In addition, filters may be needed in interconnected wiring designs to prevent HEMP signal conduction to circuits inside the enclosure. To prevent the voltage/current limits of a filter from being exceeded, transient suppressors may be required in front of the filter. Spark gaps often are used to protect power lines, but they generally have rather slow response times. In this case, the fast-rising leading edge of the HEMP pulse can couple past the spark gap. For this reason, filters (or fast-response transient suppressors such as MOVs) may be used along with the spark gaps. Fast-response transient suppressors rather than filters may be required, depending on the level of the residual peak-voltage spike. For example, suppose a spark gap is used to protect a 440-volt a.c. power line from HEMP-induced transients and a filter is first contemplated to follow the spark gap. It is reasonable to expect a 12-kilovolt residual peak voltage spike after the spark gap due to the spark gap's slow firing properties. At this voltage level, filters may be susceptible to arcing or damage or they may be very expensive to design to withstand such voltages. Therefore, a high-speed transient suppressor, such as an MOV, should be specified in addition to a filter.

(4) Filter installation and mounting. To achieve the desired results with filters, it is necessary to adhere to certain guidelines when installing and mounting them. The RF impedance between the filter case and ground must be made as low as possible. Otherwise, the filter insertion loss may be seriously degraded at the higher frequencies. The preferred contact between the filter case and ground is made by a metal-to-metal bond between the filter case and the shielded enclosure wall, entry vault, or equipment chassis. In addition, effective isolation is mandatory between the filter's input and output wiring to prevent radiation from the input wiring to the output wiring from circumventing or degrading the filter's performance. This isolation can be achieved in either of two ways. The most common approach is to use a bulkhead-mounted feedthrough type of filter in which an effective RF bond is established between the shield and the filter case at the circumference around the feedthrough flange. In this type of filter, the input and output wiring are isolated internally. The second approach requires the use of a shielded filter enclosure that can contain one or more filter modules. A bulkhead is included in the enclosure to isolate the input and output wiring and the filter modules are mounted to the bulkhead using appropriate gasketing.

EP 1110-3-2
31 Dec 90

(5) Specifying filters. In selecting a filter for a particular use, many parameters must be taken into account to insure effectiveness. The attenuation versus frequency characteristic is the main factor that determines a filter's suitability for a particular use. However, other electrical and mechanical requirements must be specified, as described in paragraphs (a) through (h) below.

(a) Impedance matching. The input and output impedances must be specified to match the impedance of the line into which the filter will be inserted. Impedance matching is especially critical for transmission lines, so that the filter does not impair the normal operation of the equipment on both ends of the line. In addition, care must be taken that the filters to be used do not degrade the desired performance of circuits in the system. This includes prevention of waveform distortion and proper impedance matching to prevent line reflections.

(b) Voltage rating. The voltage rating of the filters must be specified to insure that each filter is correct for its particular use. The filter voltage ratings must be high enough for reliable operation under the extreme conditions expected. However, specifying a rating higher than required will bring penalties in size, weight, and cost.

(c) Current rating. The filter's current rating should be specified for maximum allowable continuous operation of the circuit in which it is installed. It should agree with the current rating for the wire, components, circuit breakers, and fuses with which it will be used.

(d) Voltage drop. The maximum allowable voltage drop through the filter should be specified. With the maximum current specified, the voltage drop requirement specifies the maximum passband insertion loss of the filter.

(e) Frequency. The relative frequencies and magnitudes of the desired and undesired signals must be considered when specifying filter frequency properties. In general, the size, weight, and cost of a filter rise rapidly as the attenuation slope increases.

(f) Environment. Filters must be able to withstand the environmental operating ranges of the equipment in which they are used. The specified temperature range for the filters must include both the extreme low and the extreme high temperatures in which the equipment will have to operate.

(g) Size and weight. In most cases, size and weight will be important considerations in choosing filters. Filter manufacturers are fairly flexible in being able to provide a wide choice in the filter case shape, method of mounting, and types of terminals and connectors.

(h) Load balancing. A common practice in powerline filter installation is to place two or more filters in parallel to enable standard filters to meet current handling and voltage drop specifications. If this is

done, and if one of a parallel bank of filters fails to an open-circuited condition, then the current that had been handled by the failed filter will be added to the load of the other filters in the parallel bank. This additional load may be enough to cause the other parallel filters to fail as well. It is thus important that filters be designed such that the most likely failure model is a short-circuit to ground, which will cause the protective circuit breaker for that circuit to open before damage occurs to parallel filters.

c. Common mode rejection (CMR). CMR devices are used to attenuate common-mode signals in differential-mode systems. CMR refers to a device's ability to attenuate common-mode signals and to prevent conversion of these signals to differential-mode signals at the input leads. For example, if a device has a CMR ratio of 60 decibels, a 1-volt common-mode signal looks like a 0.001-volt differential-mode signal at the device output.

(1) Balanced cables. Common-mode signals that couple to cables outside the facility can be converted to differential-mode signals at the equipment level if balanced cables are not maintained or if shields are not fully intact on signal, control, and antenna inputs. This mode conversion can also occur if transient suppressors and filters used to protect balanced lines are not designed and installed properly. For a.c. power, the facility transformer should be configured delta-wye to increase CMR.

(2) Improving CMR. To improve CMR, balanced lines, baluns, and isolation techniques should be used wherever possible to protect signal, control, and antenna cables. When transient suppression is required on a balanced line, the suppression devices must have the same breakdown characteristics and breakdown times to prevent the common-mode signal from appearing as a differential-mode signal at the balanced input. Transient suppressors rarely have well controlled firing properties. Therefore, spark gaps with a three-element common chamber spark gap are used because if one gap fires, the other is forced to fire simultaneously. With SASS and MOVs, the devices should be packaged together and must have similar breakdown characteristics. Special engineering designs may be required to achieve satisfactory results.

(3) Examples of balanced cable designs. Figure 5-74 gives examples of balanced cable designs to achieve high CMR ratios. Figure 5-74 shows both a shunt-connected balanced transformer arrangement using a twisted-pair cable and a series-connected transformer circuit using twisted pairs. The shunt-connected transformer circuit has the advantage of providing ground isolation, if the center taps are left floating--a feature not present in series-wound configurations. For a typical circuit using a series transformer with an ideal ground, no common-mode signal appears at the output. In actual operation, none of these ideal conditions occur and some common-mode signal conversion takes place. Another example of CMR is the use of a delta-wye power transformer.

EP 1110-3-2
31 Dec 90

d. Isolation. Isolation techniques involve breaking or opening the transient signal path to prevent the transfer of unwanted signal energy. These techniques include fiber optics, dielectric separators in metallic conductors such as sewer and water pipes, dielectric drive shafts, electro-optic isolators, and isolation transformers. Other isolation techniques involve physical separation, routing, and reconfiguration to prevent mutual coupling between cables. Physical isolation methods also involve grouping electrical cables according to function, such as a.c. power, d.c. power, signal, and control and antenna lead-ins, and then shielding functional classes from each other.

(1) Fiber optic cables. Fiber optic cables do not radiate or couple EM energy the same way metallic cables do and are therefore regarded as solving EMP-related problems rather than causing them. However, HEMP problems can occur when using fiber optics. Potential problems include susceptibility of the transmitter/receiver circuitry and violation of zonal barriers if the fiber cable is not installed or specified properly. To eliminate coupling to EM fields, the fiber optic cables must have no associated metal support wires or physical protection shields. Any internal support member should be specified to be made of Kevlar or some other type of dielectric material, such as polyvinyl chloride or nylon.

(2) Waveguides for fiber cables. Fiber or fiber cable penetration through a shield requires a small metal tube used as a waveguide beyond cutoff. The fiber cable cannot have metallic components that penetrate the shield. In determining the attenuation and required length of the waveguide, the fiber material must be considered. The waveguide must be analyzed as dielectrically loaded which changes its cutoff and attenuation characteristics.

(3) Electro-optic isolators. Isolation transformers were discussed in the previous section on the use of transformers to improve CMR. Electro-optic isolators are semiconductor devices that incorporate an LED and detector in the same package. Isolation is achieved by converting the electrical input to an optical signal and back to an electrical output. Electro-optic isolators are digital devices with lights either on or off and are rather slow. Since these isolators are actually semiconductors, they are susceptible to high-power transients.

(4) Microwave isolation technique. Another possible isolation technique is to use a microwave system for communication between protected areas. Since the frequency passband required is beyond the HEMP frequency range, and waveguides can penetrate shields without compromising them, the microwave system can give complete isolation. The waveguide must be bonded to the shield enclosure at the point of entry.

5-14. Apertures.

a. Shielding. Various types of nonconductive apertures must exist within a shielded enclosure for entrances (doors), ventilation, and utilities. The HEMP protection for these apertures includes special shielding techniques, WBC ports, or a combination of these techniques.

(1) Doors/personnel entry.

(a) Personnel and cargo entrances are protected by RFI shielded doors. Fingerstock is usually advised. Pneumatic pressure seal sliding doors can be used for large or seldom opened entrances. The doors should be specified with a decibel rating slightly higher than that of the facility shield since they tend to degrade.

(b) Door closure designs must also provide good electrical continuity between the door and frame. Figure 5-75 shows typical designs that maintain electrical continuity with two rows of electrical fingerstock; magnetic continuity is maintained with a steel coverplate that makes good contact with the door surface and adjacent wall shield (ref 5-7). The fingerstock is made of spring material with high conductivity, such as beryllium copper or phosphor bronze, to make tight contact with the door frame. The fingerstock generally mates with a brass or copper plate to ensure electrical contact. More sophisticated doors are the sliding type with pneumatic closers that provide pressure at the mating surfaces (usually knurled) to better assure electrical contact between the door and frame.

(c) A carefully made door closure in good condition can attenuate EMP signals as much as 100 to 120 decibels. However, wear of the parts and loss of contact due to metal fatigue, dirt, grease, or paint can seriously degrade the attenuation. Therefore, regular monitoring, cleaning, and maintenance (replacement) are needed. The choice of door design depends on the overall shielding requirements, cost, and operational surveillance and maintenance requirements. For low SE requirements (less than 50 decibels), a single row of fingerstock is required. Higher performance (60 to 120 decibels) can be obtained using double rows of fingerstock. Sliding doors that have pneumatic closures and knurled surfaces can achieve up to 120 decibels. Fingerstock type doors, although designed to provide a wiping action when the door is opened or closed, still require monthly cleaning and maintenance. The fingerstock also is susceptible to damage if not protected as in figure 5-75. Fingerstock ages (work-hardens) and in time will require replacement. The sliding doors achieve higher initial attenuation but due to their sophistication, tend to have high breakdown rates and long down-times. Further, sliding doors are expensive and require an air supply system. In general, they are not recommended for high-use areas, but are very effective for large doors that are not used often.

(d) When both doors are closed, the overall SE of the facility entryway can be much higher than that obtainable with a single door. Conversely, the SE of each door could be relaxed and still maintain the desired shielding level. This design can reduce the monitoring and

EP 1110-3-2
31 Dec 90

maintenance functions since some degradation could be tolerated. In addition, a vestibule can provide a weather-resistant entryway; that is, the shielded inner door would not be exposed to the weather, and again, maintenance (cleaning) requirements would be reduced. Another reason for using a vestibule is if the ambient EM environment is always present (for example, nearby radar or communications sites) and maximum protection must be maintained due to a high level of mission criticality. In this case, both doors must be able to provide the required SE. Further, the doors should be interlocked so that only one door can be opened at any time.

(e) In some facilities, waveguide tunnels are installed to achieve the required SE without shielded doors. A waveguide tunnel is a metal extension of the enclosure. This approach has been used in some buried facilities where the high-frequency EM environment is attenuated by the earth overburden. Entryways formed in this way use waveguides-below-cutoff. For large openings, such as personnel access doors, this requires the EM environment be reduced to a few megacycles; the actual frequency depends on the door size required and the length of the waveguide since the waveguide attenuation is a function of size and the amount the interfering frequency is below the waveguide cutoff frequency. The advantage of this approach is that tunnels are maintenance-free (they do not degrade with time). Care must be taken that no conductor of any type (mechanical penetrants or electrical penetrants) is ever allowed to enter the facility via these tunnels. Adding a conductor to the tunnel transforms the waveguide into a propagating structure—that is, a coaxial structure that has no cutoff frequency.

(2) Other access ports. Occasionally, facilities may have access ports not normally used and therefore only opened occasionally. Figure 5-76 shows an emergency escape hatch for a buried facility that uses a bolted hatch with gaskets. Most mesh gasketing material, if compressed more than a few times or for long periods, deteriorates beyond use and must be replaced.

(3) Air ducts. Air ducts for ventilation must be treated with WBC techniques. Both wire screens and honeycomb are used for this purpose. Figures 5-77 and 5-78 show typical methods of installing screens over a ventilation aperture. Honeycomb shielding of an air vent is shown in figure 5-79. As already discussed, honeycomb is preferred over wire screen since it can be designed to provide much better shielding with less resistance to air flow.

b. Waveguide-below-cutoff (WBC).

(1) Tunnels. Openings in a shield can be treated by forming them into a metal-lined tunnel that acts as a WBC, where the cutoff frequency is defined by the opening dimensions as given in equations 5-23 and 5-24 (para 5-6). The attenuation provided by a rectangular WBC opening also is given by equation 5-23. Figure 5-80 shows the attenuation that can be achieved for tunnels of various depths and wall dimensions.

(2) Tunnels and grills. Combinations of WBC tunnels and grills can be used to decrease HEMP coupling through air vents, as figure 5-81 shows. The duct is continuous metal, welded and bonded to the facility shield. This method should be considered only when honeycomb cannot be used as in some diesel exhaust systems where soot could collect.

5-15. Utility penetrations.

a. Overview. At the facility level, nonconductive utility penetrations generally include water and sewage pipes, fuel lines, and air-conditioning lines. Depending on the facility configuration, such lines could also penetrate internal enclosures. Utility penetrations must be treated properly to maintain the facility's shielding integrity.

b. Conductive penetrations. Figure 5-82 and the upper part of figure 5-83 show the treatment of a metallic pipe or waveguide that penetrates a shield. Note that the pipe or waveguide circumference is bonded to the shield to maintain closure. All currents on the pipe will thus be diverted onto the shield exterior (or to earth). These penetrants should enter the facility through an entry vault area to maximize the protection provided.

c. Nonconductive penetrations. For nonmetallic pipes, such as water or sewage lines made of plastic, or for cast iron pipes that cannot be bonded easily, electromagnetic closure of the hole in the shield where the pipe must penetrate is not feasible. However, the shield will be isolated for HEMP currents induced on a water or sewage system since the penetrating pipe is nonconducting. To maintain shield integrity, a metallic sleeve must surround the nonconductive pipe to form a WBC protection device (figure 5-84). The sleeve must be welded to the shield around the sleeve circumference. Metal pipes also must be welded to the shield around their circumference and must form WBC entry points. Both types of WBC must conform with maximum allowable diameters as defined earlier.

(1) Pipes carrying fluids. Often it is necessary to penetrate shields with pipes carrying fluids such as water, sewage, refrigerants, fuels, and other chemicals. Since the electrical parameters of the fluids are much different from those of air, the cutoff frequency and attenuation in a waveguide-beyond-cutoff must be determined for the specific fluids.

(2) Impact of fluids on waveguides. One study has assessed the impact of fluids on waveguide performance (ref 5-20). Figures 5-85 and 5-86 show variations in attenuation and cutoff frequency. Figure 5-85 shows the attenuations for loss tangents varying from 0.0 to 0.5 in 0.05 increments; figure 5-86 shows families of curves for the cutoff frequencies of pipe inside diameters 2.54 centimeters (top curve), 3.81 centimeters, 5.08 centimeters, 6.35 centimeters, 10.16 centimeters, and 15.24 centimeters.

5-16. Bonding.

EP 1110-3-2

31 Dec 90

a. Purpose. Bonding is the process by which two or more conductive materials are joined together to achieve and maintain a low-impedance electrical path. In the design, implementation, and maintenance of EMP-shielded facilities, bonding is one of the most important considerations. In general, many joints in the electrical conductors and supporting structures will exist in every installation. These joints must be joined properly such that, ideally, each bond has both the mechanical and electrical properties of the conductors on either side of the joint, not only when formed, but independent of time.

(1) Potential differences. Adequate bonds are necessary to prevent the development of potential differences that may be important sources of HEMP coupling. Good bonds provide electrical homogeneity to shielded enclosures and minimize potential differences between conductive equipment frames, enclosures, and cables.

(2) External fields. Bonding also is required for protecting electronic equipment and circuitry from external fields. Good bonds are essential to proper performance of EM shields and filters. For example, consider a typical power line filter like the one shown in figure 5-87. If the return side of the filter (usually the housing or case) is not well bonded to the reference plane (typically the power entrance vault), the bond impedance, Z_B , may be high enough to impair the filter's performance. The filter shown is a low-pass filter-- the type that can be used to remove HEMP from equipment power lines. The filter works partly because the reactance of the shunt capacitors, X_C , is low over most of the HEMP spectrum. HEMP spectral components present on the a.c. line are shunted to ground along path 1 and thus do not reach the load. If Z_B is high relative to X_C , however, HEMP energy follows path 2 to the load, and the filter's effectiveness is compromised.

(3) Equipotential surfaces. Shielded enclosures should be bonded to provide a seam conductivity nearly equal to the shield material conductivity and the mechanical strength required at every seam and discontinuity. Cable shields must be bonded to the enclosure with maximum practical conducting area. All equipment should be bonded to the ground plane through the lowest possible impedance and the ground bus system must be bonded together well enough to insure that the reference plane is as homogeneous and near to an equipotential surface as possible.

b. Techniques. Bonding techniques are generally classified as direct or indirect. Direct bonding is always preferred; however, it can be used only when the two members can remain joined, either permanently or semipermanently. When joints, seams, hinges, or other discontinuities must be bridged, indirect bonding with bonding jumpers is necessary. Indirect bonding is at best only a substitute for direct bonding and should be used only when no other option exists for a HEMP-protected facility.

EP 1110-3-2
31 Dec 90

(1) Direct bonding. Direct bonding is achieved by maintaining bare metal-to-metal contact between two surfaces with a high, uniform pressure or through metal flow processes. Properly constructed direct bonds have a low d.c. resistance and an RF impedance as low as the conductor configuration will permit. Permanent joints can be bonded directly by welding, including conventional gas, MIG, electric, and exothermic weld techniques. MIG welding is preferred for joining seams in enclosures constructed of steel. Conventional welding (gas or electric) can be used for bonding cable trays. Seams in aluminum enclosures must be bonded by heliarc welding. Copper or brass enclosures can be bonded by soldering or brazing techniques.

(a) Exothermic (Cadweld) welding is a good way to join rebar and to bond conductors of the earth electrode system. In this process, a mixture of aluminum, copper oxide, and other powders is held in place with a mold around the conductor joint. The mixture is then ignited, and the heat generated melts the conductors to form an uninterrupted path between the two. This process is particularly advantageous for bonding copper cables to steel I-beams when corrosion prevention in steel may be difficult, and for bonding counterpoise cables to ground electrodes when future access to the bonds for maintenance would be impossible or impractical.

(b) Soldered bonds should not be used to bond joints subject to carrying high currents as in fault clearance and lightning discharge paths where physical strength is required. A soldered connection produces a higher bond resistance than does a metal flow process. Cold solder joints are an ever-present possibility. The main objection to soldered joints is that, under heavy currents, the bond may heat, melting the solder with subsequent bond failure and loss of protection. Other drawbacks are that mechanical strength of the soldered connection is much less than that of the conductors and the bond may fail when conductors flex or vibrate.

(c) Joints that must be disconnected at times for maintenance or other purposes are most commonly made with lock-threaded devices (such as bolts) or clamped fittings (such as conduit clamps). To achieve a low-resistance joint with either bolted or clamped bonds, the conductor's mating surfaces must be cleaned thoroughly, with all rust and corrosion, paint, anodizing, and protective finishes removed. Bond surfaces should be sanded bright and the final sanding should be done with a very fine grit paper. Completed surfaces should be joined soon after sanding to prevent reformation of oxide films and to limit moisture and dust collection. All bolts and other fasteners should be tightened enough for close mating over a wide range of temperatures and vibrations. Figures 5-88 through 5-92 show the required surface preparation for various types of bolted bonds.

(d) Clamped fittings are frequently used to bond wires or straps to small pipes and other cylindrical objects. Cleaning procedures similar to those used for bolted connections should be used before making a clamped fitting, as figure 5-92 shows. On curved surfaces, a toothed washer often

EP 1110-3-2

31 Dec 90

must be used under the clamp jaws to insure that the bond will hold and will continue to hold under temperature and vibration stresses.

(e) The main disadvantage of clamped and bolted connections is that they are much more susceptible to corrosion than are permanent bonds. With both types of semipermanent bonds, it is recommended that the cleaned surface be coated with a protective, conductive surface treatment. Examples of this type of treatment are irridite or alodine for aluminum and tin for steel using a brush-plating method. Whether or not a conductive surface treatment is applied (but especially if it is not), exposed edges around the bonded joint should be coated with an effective moisture barrier to prevent corrosion. Periodic maintenance is required to insure bonding integrity. As part of this maintenance, bonds should be checked for signs of corrosion, looseness, or other deterioration.

(2) Indirect bonding. Indirect metal bonding requires a bonding jumper. These bonds are commonly used in facility areas where bonded members must be able to move, such as at access doors to test chambers, network distribution boxes, and circuit monitoring panels. Indirect bonds are formed with flexible metal straps or conductors and often can disconnect quickly for easy removal. Bond quality is inferior to that provided by the direct bond, and the maintenance problem is much more severe. Being subject to motion and vibration, indirect bonds frequently fail with time because of metal fatigue or corrosion. Therefore, special effort should be made in the maintenance program to check and replace bonding straps as soon as these begin to deteriorate.

(a) For d.c. or low-frequency a.c., equipment is easily bonded with jumpers. A wide metal strip or flat copper braid is adequate. However, jumpers must be used with care when bonds are to provide a path for RF currents. There is almost no correlation between the d.c. resistance and the RF impedance characteristics of bonding jumpers (ref 5-21). At very low frequencies, bonding jumper impedance is primarily a function of the conductor size and the quality of metal-to-metal contact (refs 5-22 and 5-23). The conductor's geometrical configuration and the physical relationship between the equipment and the reference plane introduce reactive components into the impedance characteristics of the bonding path. A certain amount of stray capacitance is inherently present between the bonding jumper and the objects being bonded and between the bonded objects themselves. Figure 5-93 shows an equivalent circuit for the bonding strap alone. R_S represents the strap a.c. resistance, L_S is the inductance, and C_S is the stray capacitance between the jumper and the two members being bonded. Except for extremely short straps, the magnitude of the strap's inductive reactance will be significantly larger than the resistance and, at frequencies above approximately 100 kilohertz, the R_S term can be ignored. Thus, not considering R_S , the equation for the impedance, Z_S , of the equivalent circuit is--

EP 1110-3-2
31 Dec '90

$$Z_s = \frac{wL_s}{1 - w^2 L_s C_s} \quad (\text{eq 5-35})$$

For a flat, solid strap, at frequencies where the skin depth is well developed and the bond strap thickness is greater than three skin depths, the effective resistance and inductance are given approximately by--

$$R_s = \frac{\rho}{Dw} \text{ ohms/meter length} \quad (\text{eq 5-36})$$

$$L_s = \frac{\rho}{wDd} \text{ henrys/meter length} \quad (\text{eq 5-37})$$

where D is the strap width; d is the skin depth ($= [p/(\pi)fu]^{0.5}$); p is material resistivity; and u is material permeability. C_s is approximated by--

$$C_s = \frac{eA}{d} \quad (\text{eq 5-38})$$

where A is the common area; d is the distance between equipment and ground plane; and e is the permittivity of the media. The equivalent circuit of figure 5-93 does not account for the effects of the equipment enclosure or other object being bonded. Figure 5-94 shows the true equivalent circuit of an indirectly bonded system. The bonding strap parameters are again represented by R_s , C_s , and L_s .

(b) The inherent inductance of a bonded object, such as an equipment rack or cabinet, is represented by L_C , and the capacitance between the bonded members, that is, between the equipment and its reference plane, is represented by C_C . In most situations, $L_s \gg L_C$, $C_C \gg C_s$, and R_s can again be ignored. Thus, the primary (lowest) resonant frequency is given by--

$$f_r = \frac{1}{2(\pi) (L_s C_s)^{0.5}} \quad (\text{eq 5-39})$$

These resonances can occur at surprisingly low frequencies-- as low as 10 to 15 megahertz in typical configurations. Near these resonances, bonding path impedances of several hundred ohms are common. Such high impedances make the strap ineffective. In fact, in these high-impedance regions, the bonded system may act as an effective antenna, increasing pickup of the same signals that the bond straps are intended to reduce (ref 5-21). Bonding straps should therefore be designed and used with care, making special efforts to ensure that unexpected coupling does not occur from using such straps.

c. Bond protection. Both directly and indirectly bonded joints that are held together mechanically deteriorate with time. Corrosion develops increasing contact resistance markedly when oxidation products are deposited

EP 1110-3-2
31 Dec 90

at the point of contact. These oxidation products can form electrical diodes that behave as nonlinear elements. Hence, a corroded joint can be a source of harmonics and mix products of the signal currents flowing through the junction (ref 5-6).

(1) Source of corrosion. Corrosion can result from electrolytic or galvanic action or a combination of the two. Galvanic corrosion is a function of moisture content in the ambient environment. With enough moisture, the two contact surfaces form a chemical wet-cell battery. Each surface behaves like an electrode immersed in a conducting solution. Positively and negatively charged ions leave the surfaces and pass into the solution. If the two surfaces are of the same material, the ion transfer is small and the net surface change is small. If the metals differ chemically, one will erode because of the rapid transfer of ions into solution.

(2) Galvanic series. Table 5-25 shows the relative placement of common materials in the galvanic series. A particular metal will lose positive ions to the metals below it in the series. The metal higher in the series is eroded in the process. The farther apart the metals are in the series, the more rapid is the corrosion. Thus, if dissimilar metals must be joined, the most easily replaceable part of the bond should be made of the metal higher in the series. A common practice is to insert a sacrificial washer between the two main conductors. This washer is made of a material falling at an intermediate point in the galvanic series. The washer is replaced periodically as it deteriorates.

(3) Electrolysis. Bond corrosion can also be caused by electrolytic action. If d.c. flows between two metals through a conducting solution, the metals will tend to ionize into the solution. With common battery systems, electrolysis can cause serious bond corrosion.

(4) Effect of moisture. Moisture is needed to form the electrolytic solution in the joint and hence is the greatest single cause of corrosion. Some moisture is present in almost every environment; therefore, no installation is completely immune to corrosion. For example, dust attracts and holds moisture on surfaces. Organisms such as mold, fungi, and bacteria may inhabit the moisture, producing acids that destroy protective metal coatings, or they may actually initiate corrosion by causing potential differences between the bond members (ref 5-24). Salt sprays and other corrosive atmospheres have long been recognized as detrimental to bonded junctions. Air pollutants are an increasing problem because many form corrosive acids in the presence of water. Salts and acids cause the formation of high-resistance compounds in the joint in addition to eroding the bonding member metal.

(5) Summary. Bond corrosion can create many problems if it is not controlled. Ideally, both bond members should be of the same material. If dissimilar metals must be bonded, they must be as close together in the galvanic series as possible. All bonded joints must be perfectly clean,

tight, and dry when formed, and a proper protective coating must be applied after the bond is formed. The protective coating must completely seal the joint to prevent moisture from entering the bond. Figure 5-95 shows preferred practices for protecting bonds.

5-17. Grounding.

a. Concepts. Grounding is the electrical attachment of equipment and buildings to earth or to other metal objects in an area already in electrical contact with earth. For electrically powered equipment, the purpose of this contact with earth or grounded objects is to establish a low-impedance path back to the power source--the transformer, generator, or battery--to permit rapid clearance of faults for reduced hazards of fire and electric shock. By establishing a low-impedance path between exposed metal parts of electrically powered equipment and grounded metal objects subject to human contact, the threat of exposure to hazardous voltages in the event of a fault is reduced greatly.

(1) Lightning protection. Buildings and equipment exposed to lightning should be grounded to provide a preferential path to earth for lightning stroke currents and to prevent hazardous voltages from developing between metal objects by the high-amplitude, fast-risetime waveforms produced by stroke currents.

(2) Grounding buildings. Protection against electrical fault and lightning are the primary purposes of grounding. Any building provided with electrical power must be grounded properly in accordance with National Electric Code principles (ref 5-25). A dedicated lightning protection network may be required, depending on the type of facility and the degree of lightning exposure (ref 5-6).

(3) Interfacing electronic equipment. Electronic equipment for instrumentation, communication, data processing, surveillance, and other functions must interface properly to the safety and lightning protection grounding networks without suffering unacceptable degradation in performance. To achieve noise- and interference-free electronic equipment performance without violating safety and lightning protection principles, the electrical ground network, lightning protection network, and electronic grounding system must be designed properly and installed and maintained carefully. Correct bonding techniques must be used and the grounding system must not violate the integrity of any electromagnetic shield.

(4) Grounding system as electrical circuit. As a network of conductors, the grounding system has resistance, inductance, and capacitance properties. In other words, the grounding system behaves as an electrical circuit. Voltage drops can occur because of stray or return currents in the system. The system also may act as an antenna to radiate EM energy into the environment or may have voltages and currents induced onto it from incident EM environmental signals. For example, a HEMP can induce very large currents and

EP 1110-3-2
31 Dec 90

voltages onto the ground network "antenna." These ground network currents and voltages pose a serious threat of damage to electronic components unless specific steps are taken to minimize HEMP coupling to the grounding system.

b. Techniques.

(1) Zonal boundaries. In an integrated approach to internal facility grounding based on the zonal concept, simplicity and uniformity of application are achieved by requiring each zonal boundary to be treated the same regardless of the shield quality. To limit damaging potentials in a given zone, all metal parts in the zone, including the outer surface of the next higher order zonal boundary, must be grounded to the zonal boundary's inner surface with a single ground conductor (fig 5-96). If low-frequency magnetic field penetration is a major problem, a single-point grounding system interior to a zone is a potential solution. If good SE is obtained across the entire HEMP spectrum, the type of grounding connection used becomes less important. The single-point ground concept is practical for low-frequency systems in which the ground lead inductance does not introduce a significant ground impedance. For high-frequency systems using the ground connection as a reference, a single-point ground's extended conductors would introduce too high an impedance at the system's operating frequency to be used as a reference. Therefore, practical grounding usually is a combination of single-point (low-frequency systems) and multipoint (high-frequency systems) approaches. The multipoint approach includes equipotential planes which are required by MID-STD-188-124 (ref 5-26). Ground wires must not penetrate zonal boundaries to ensure that SE is not compromised. If local codes require ground wires to penetrate boundaries, they must be treated like any other penetration with limiters, filters, or other protective measures.

(2) Soil as a dissipative medium. Conductors outside the facility, such as power lines, signal lines, and utilities, pose a particular challenge. Consider the typical facility containing sensitive electronic elements such as centers for communications, message switching, and computers. When supplied with utilities such as water, fuel, sewage lines, and electricity, and with external communications links such as telephones and data lines, and when protected against lightning with a proper protection system (including its earth electrode system), a complex array of potential HEMP collectors exists in Zone 0. These Zone 0 collectors act as an antenna to intercept HEMP and produce potentially damaging voltages and currents at facility penetrations. To minimize the level of threat in the facility, the voltages and currents appearing at entrance points must be reduced to levels that are equal to or less than those expected to couple through zonal barriers, or below the damage thresholds of critical equipment inside the facility. Soil, a lossy

*The net threat appearing at any particular equipment port is the vector combination of effects arising from the penetrating HEMP field, the conducted voltages and currents resulting from induced currents on external collectors, and the secondary EM fields produced by the induced collector currents. The

dielectric, may help dissipate much of the EMP energy induced on external collectors. To make effective use of the soil as a dissipative medium, however, the conductor's penetration point through the Zone 0/1 barrier must be controlled carefully. In addition, an earth electrode system must be installed that offers the necessary high-frequency performance needed for HEMP grounding.

(3) Alternate grounding means. The National Electrical Code in the United States permits electrical safety ground attachment to metal utility pipes, preferably the cold water main. When such connections are neither possible nor reliable (as in the case of plastic water lines, for example), the code specifies "made" electrodes consisting of rods, grids, plates, or other configurations of buried metal. Each has certain advantages and disadvantages, as table 5-26 summarizes. Because of their low-impulse impedance, horizontal wires are the best choice for HEMP grounding. Vertical rods may be added to the horizontal wires to achieve the lower, more stable resistance to earth desirable for power safety grounding.

(4) Ring ground. Lightning protection practices emphasize using buried horizontal bare conductors to encircle the structure (building or tower) and form a "ring" ground. The various potential lightning discharge paths such as intentional downconductors, tower legs, and building columns are attached to this ring ground. A major advantage of such a distributed ground electrode is that it offers a shortened distance for the discharge current to travel before entering the soil since the electrode can be routed to be near the lightning downconductors. Second, the ring ground electrode offers the desired low-impulse impedance contact with earth. An electrode configuration meeting the minimum needs of both electrical safety and lightning protection is shown in figure 5-97 for a rectangular structure and in figure 5-98 for an irregularly shaped structure.

(5) Configuration of collectors. An earth electrode system suitable for HEMP protection should offer the lowest possible impulse impedance to earth (ref 5-27). However, because of the magnitudes of currents that can be induced onto Zone 0 conductors and conducting surfaces, it is not desirable to allow HEMP-related currents to flow through or over a structure to reach the grounding electrode (fig 5-99). Therefore, the external collectors (utilities, power/signal lines) should be configured to enter the shielded area at a controlled point, which should have a very low-impulse impedance earth electrode adjacent to it. Inside the facility, grounding networks must be designed and installed to achieve and maintain the required fault protection, electrical noise reduction, and HEMP pickup protection. Figure 5-96 shows a simplified way to configure grounding networks inside the various zones. Within each zone, the grounding systems for signals and safety should

relative contribution of each of these effects has not been clearly established. Intuitively, however, the long external collectors appear to be the major contributor because they typically present a large effective aperture.

EP 1110-3-2
31 Dec 90

perform their intended function without degrading the HEMP protection of the zonal boundaries. Also, the ground systems should minimize HEMP-related voltages and currents "picked up." For example, ground wire length should be minimized so it will be an inefficient monopole antenna, and the area of "ground loops" should be minimized so it will be an inefficient loop antenna. In addition to these basic requirements, the ground systems must interface with the zonal boundaries at the single entry panels. Random, uncontrolled interconnections between conductors can create loops that may serve as efficient HEMP energy collectors. Furthermore, uncontrolled interconnections make it difficult to define zonal boundaries and can make upgrading the shielding of these boundaries complex. For these reasons, a single-point ground configuration should be used within the shielded zones for low-frequency systems. If a multipoint ground configuration is required by a particular system within a zone, such as a computer or a high-frequency system, then a hybrid ground configuration is permitted. This configuration is one in which a multipoint ground network is grounded at a single point to the zonal boundary interior (fig 5-100).

(6) Single-point grounding. Figure 5-101 shows two acceptable configurations for single-point ground systems. The single lines between each component in these configurations represent all connections (power, signal, ground) between the components. The lines, for example, can represent ducts or raceways that hold all conductors passing between components. All signal and power cables should be protected with shields, conduit, or closed ducts. Care must be taken to ensure that loops are not formed by the duct or cable tray system.

5-18. Cited references.

- 5-1. Schelkunoff, S. A., Electromagnetic Waves (D. Van Nostrand Co., Inc., 1943).
- 5-2. Everett, W. W., Jr., Topics in Intersystem Electromagnetic Compatibility (Holt, Rinehart, and Winston, Inc., 1972).
- 5-3. Engineering Design Handbook--Electromagnetic Compatibility, DARCOM-P 706-410 (U.S. Army Materiel Command, March 1977).
- 5-4. Miletta, Joseph H., et al., Defense Switched Network Design Practices for Protection Against High-Altitude Electromagnetic Pulse, HDL-SR-82-2 (Harry Diamond Laboratories, July 1982).
- 5-5. EMP Engineering and Design Principles (Bell Telephone Laboratories, 1975).

FP 1110-3-2
31 Dec 90

- 5-6. Denny, H. W., et al., Ground, Bonding, and Shielding Practices and Procedures for Electronic Equipments and Facilities, Vol I-III-Fundamental Considerations, Report No. FAA-RD-75-215, (Engineering Experiment Station, Georgia Institute of Technology, December 1975).
- 5-7. EMP Engineering Practices Handbook, NATO File No. 1460-2 (October 1977).
- 5-8. Cain, B. L., EMI/RFI Gasketing for Tactical Shielded Shelter Door Seam Applications, Draft USAF Report (USACERL, March 1983).
- 5-9. Corrosion Control and Electrical Conductivity in Enclosure Design, ARP1481 (SAE, May 1978).
- 5-10. Rogers, S. R., et al, Engineering Design Guidelines for Electromagnetic Pulse Hardening of Naval Equipment, Final Report (Electromagnetic Applications, Inc., Denver, CO, under contract no. N60921-80-C-01 for the Naval Surface Weapons Center, 15 July 1981).
- 5-11. Knowles, E. D., and L. W. Olson, Cable Shielding Effectiveness Testing, Electromagnetic Pulse Protection and Engineering Management Note 14 (Lawrence Livermore Laboratory, 1973).
- 5-12. Martin, A. R., and S. E. Emert, "Shielding Effectiveness of Long Cables," Proc. 1979 IEEE International Symposium on Electromagnetic Compatibility, 9-11 October 1979, San Diego, CA.
- 5-13. Vance, E. F., Coupling to Shielded Cables (Wiley-Interscience, 1978).
- 5-14. Graf, W., J. Hammand, and E. F. Vance, "Relative Importance of Electromagnetic Shield Violations," Proceedings of the Eighth International Aerospace and Ground Conference on Lightning and Static Electricity (FAA, 21-23 June 1983), pp 8-1 through 8-8.
- 5-15. MIL-C-39012C, General Specification for Radiofrequency Coaxial Connectors (U.S. Department of Defense [DOD]), 11 August 1982).
- 5-16. Butler, C. M., D. R. Wilton, K. F. Casey, S. K. Chang, F. M. Tesche, and T. K. Liu, "Selected Topics in EMP Interaction," EMP Interaction Notes, Note 339 (AFWL, August 1976).
- 5-17. Nielsen, P., EMP/EMI Hardening of Electrical Conduit Systems, U.S. Army Construction Engineering Research Laboratory (USACERL) Technical Report M-292/ADA107133 (USACERL, September 1981).

FP 1110-3-2

31 Dec 90

- 5-18. Leverenz, D. J., R. G. McCormack, and P. H. Nielsen, EMP Shielding Properties of Conduit Systems and Related Hardware, USACERL Technical Report G19/ADA012729 (USACERL, June 1975).
- 5-19. Croisant, W., P. Nielsen, D. Sieber, and R. McCormack, Development of Conduit Design Analytical Procedures, USACERL Interim Report M-234/ADA056218 (USACERL, June 1978).
- 5-20. McInerney, M. K., S. Ray, R. G. McCormack, S. Castillo, R. Mitra, and R. Axford, The Effect of Fluids on Waveguide-Below-Cutoff Penetrations as Related to Electromagnetic Shielding Effectiveness, USACERL Draft Technical Report (October 1983).
- 5-21. Denny, H. W., "Some RF Characteristics of Bonding Systems," IEEE Transactions on Electromagnetic Compatibility, Vol EMC-11, No. 1 (February 1969), pp 15-22.
- 5-22. Denny, H. W., and W. B. Warren, RF Bonding Impedance Study, RADC-TR-67-106, Contract AF 30(602)-3282 (Engineer Experiment Station, Georgia Institute of Technology, March 1967).
- 5-23. Evans, Ross W., Metal-to-Metal Bonding for Transfer of Radio Frequency Energy, IN-R-ASTR-64-15 (Astronics Laboratory, Marshall Space Flight Center, 25 June 1964).
- 5-24. Roessler, G. D., "Corrosion and the EMI/RFI Knitted Wire Mesh Gasket," Frequency Technology Vol 7, No. 3 (March 1969), pp 15-24.
- 5-25. National Electrical Code, NFPA 70 ANSI C1 (Quincy, MA: National Fire Protection Association).
- 5-26. MIL-STD-188-124, Grounding, Bonding, and Shielding for Common Long Haul/Tactical Communication Systems, Including Ground-Based Communications-Electronics Facilities and Equipments (DOD, 14 June 1978).
- 5-27. Denny, H. W., et al., "Supplemental Grounding of Extended EMP Collectors," DNA 5940F, contract DNA 001-80-C-0294 (Defense Nuclear Agency, 31 January 1982).
- 5-28. EMP Protection for Emergency Operating Centers, TR-61A (Defense Civil Preparedness Agency, Washington, DC, July 1972).
- 5-29. McCormack, R. G., EMI/RFI Shielding Effectiveness Evaluation of Bolt-Together Shielded Rooms in Long-Term Aging, USACERL TR-M-296/ADA102754 (USACERL, June 1981).

EP 1110-3-2
31 Dec 90

- 5-30. MIL-HDBK-335, Management and Design Guidance, Electromagnetic Radiation Hardness for Air Launched Ordnance Systems (USAF, 15 January 1981)
- 5-31. Vance, E. F., Coupling to Cables, DNA Handbook Revision, Chapter H, ADB001204 (Stanford Research Institute).
- 5-32. Roffman, G. L., Application of Filters for High-Altitude Electromagnetic Pulse Protection, HDL-TM-81-9/ADA100741 (Harry Diamond Laboratories, April 1981).

5-19. Uncited references.

Davenport, W. B., Jr., and W. L. Root, An Introduction to the Theory of Random Signals and Noise (McGraw-Hill Book Company, 1958).

Electromagnetic Compatibility Design Guide for Avionics and Related Ground Support Equipment, NAVAIR AD1115 (U.S. Department of the Navy, Naval Air Systems Command).

EMP Design Guidelines for Naval Ship Systems, NSWC/WOL/TR 75-193 (IITRI, 22 August 1975).

Hart, W. C., and D. F. Higgins, A Guide to the Use of Spark Gaps for Electromagnetic Pulse (EMP) Protection (Joslyn Electronic Systems, 1973).

Henkel, R., and D. Mealey, "Electromagnetic-Compatibility Operational Problems Aboard the Apollo Spacecraft Tracking Ship," 1967 IEEE Electromagnetic Compatibility Symposium Record, IEEE27C80 (July 1967), pp 70-81.

Jarva, W., "Shielding Efficiency Calculation Methods for Screening, Waveguide Ventilation Panels, and Other Perforated Electromagnetic Shields," Proceedings of the Seventh Conference on Radio Interference Reduction and Electromagnetic Compatibility (Armour Research Foundation/IITRI, November 1961).

Jordan, Edward C., Electromagnetic Waves and Radiating Systems (Prentice-Hall, Inc., 1950).

MIL-STD-220A, Method of Insertion-Loss Measurement (DOD, 14 December 1971).

Mukhedkar, D., and F. Dawalibi, "Ground Electrode Resistance Measurements in Non-Uniform Soils," IEEE Transactions on Power Apparatus and Systems, Vol PAS-92 (1973), pp 109-115.

Mukhedkar, D., Y. Gervais, and F. Dawalibi, "Modelling of Potential Distribution Around a Grounding Electrode," IEEE Transactions on Power

EP 1110-3-2
31 Dec 90

Apparatus and Systems, Vol PAS-92, No. 4 (July-August 1973), pp 1455-1459.

Schultz, R. B., et al., "ELF and VLF Shielding Effectiveness of High Permeability Materials," IEEE Transactions on Electromagnetic Compatibility, Vol EMC-10 (March 1968).

Schultz, R. B., et al., "Shielding Theory and Practice," Proceedings of the Ninth Tri-Service Conference on Electromagnetic Compatibility (IITRI, October 1973).

Scott, J. H., "Electrical and Magnetic Properties of Rock and Soil," Technical Letter, Special Project (U.S. Geological Survey, 16 May 1966).

Scott, L. D., and G. S. Smith, "Measurement Techniques for Antennas in Dissipative Media," IEEE Transactions on Antennas and Propagation, Vol AP-21, No. 4 (July 1973), pp 499-507.

Stratton, J. A., Electromagnetic Theory (McGraw-Hill, 1941), pp 573-579.

Transient Voltage Suppression Manual, Third Edition (General Electric Company, 1982).

Vance, Edward F., "Electromagnetic Interference Control," IEEE Transactions on Electromagnetic Compatibility, Vol EMC-22 (Institute for Electrical and Electronic Engineers, November 1980).

EP 1110-3-2

31 Dec 90

Table 5-1. Coefficients for magnetic field reflection loss*

Coefficient	Units for distance (r)			
	Meters	Millimeters	Inches	Mils
C ₁	0.0117	11.7000	0.462	462
C ₂	5.350	0.0053	0.136	136

*Source: H. W. Denny, et al., Grounding, Bonding, and Shielding Practices and Procedures for Electronic Equipments and Facilities, Vol I-II, Fundamental Considerations, Report No. FAA-RD-75-215, I (Engineering Experiment Station, Georgia Institute of Technology, December 1975).

EP 1110-3-2
31 Dec 90

Table 5-2. Absorption loss of metals at 150 kilohertz*

Metal	Relative conductivity, σ_r	Relative permeability at 150 kHz, μ_r^{**}	Absorption loss at 150 kHz, dB/mil
Silver	1.05	1	1.32
Copper, annealed	1.00	1	1.29
Copper, hard-drawn	0.97	1	1.26
Gold	0.70	1	1.08
Aluminum	0.61	1	1.01
Magnesium	0.38	1	0.79
Zinc	0.29	1	0.70
Brass	0.26	1	0.66
Cadmium	0.23	1	0.62
Nickel	0.20	1	0.58
Phosphor-bronze	0.18	1	0.55
Iron	0.17	1000	16.9
Tin	0.15	1	0.50
Steel, SAW 1045	0.10	1000	12.9
Beryllium	0.10	1	0.41
Lead	0.08	1	0.36
Hypernick	0.06	80,000	88.5***
Monel	0.04	1	0.26
Nu-Metal	0.03	80,000	63.2***
Permalloy	0.03	80,000	63.2***
Stainless steel	0.02	1000	5.7

*Source: Engineering Design Handbook--Electromagnetic Compatibility, DARCOM-P-706-410 (U.S. Army Materiel Command, March 1977).

**The relative permeability of metals changes somewhat with frequency, but becomes decreasingly important at higher frequencies.

***Obtainable only if the incident field does not saturate the metal.

Table 5-3. Absorption loss of solid copper, aluminum, and iron shields at 60 hertz to 10,000 megahertz*

Frequency	Copper		Aluminum		Iron		Absorption loss, db/mil		
	σ_r	μ_r	σ_r	μ_r	σ_r	μ_r^{**}	Copper	Aluminum	Iron
60 Hz	1	1	0.61	1	0.17	1000	0.03	0.02	0.33
1000 Hz	1	1	0.61	1	0.17	1000	0.11	0.08	1.37
10 kHz	1	1	0.61	1	0.17	1000	0.33	0.26	4.35
150 kHz	1	1	0.61	1	0.17	1000	1.29	1.0	16.9
1 MHz	1	1	0.61	1	0.17	700	3.34	2.6	36.3
15 MHz	1	1	0.61	1	0.17	400	12.9	10.0	106.0
100 MHz	1	1	0.61	1	0.17	100	33.4	26.0	137.0
1500 MHz	1	1	0.61	1	0.17	10	129.0	100.0	168.0
10,000 MHz	1	1	0.61	1	0.17	1	334.0	260.0	137.0

*Source: Engineering Design Handbook--Electromagnetic Compatibility, DARCOM-P 706-410 (U.S. Army Materiel Command, March 1977).

**Other values of μ for iron are: 3 megahertz, 600; 10 megahertz, 508; 1000 megahertz, 50.

Table 5-4. Reflection loss*

Frequency	Electric field, db**			Magnetic field, dB**			Plane wave, dB***,+		
	Copper	Aluminum	Iron	Copper	Aluminum	Iron	Copper	Aluminum	Iron
60 Hz	279	--	241	22	--	-1	150	148	113
1000 Hz	242	--	204	34	--	10	138	136	100
10 kHz	212	--	174	44	--	8	128	126	90
150 kHz	177	175	--	56	54	19	117	114	79
1 MHz	152	150	116	64	62	28	108	106	72
15 MHz	117	115	83	76	74	42	96	94	63
100 MHz	92	90	64	84	82	56	88	86	60
1500 MHz	++	--	++	++	--	++	76	74	57
10,000 MHz	++	--	++	++	--	++	68	66	60

*Source: Engineering Design Handbook--Electromagnetic Compatibility, DARCOM-P 706-410 (U.S. Army Materiel Command, March 1977).

**For signal source 12 inches from shield. Wave impedance much greater than 377 ohms. (For distances much greater than 12 inches, recalculate the reflection loss using the formulas given in text.)

***If penetration loss is less than 10 decibels total, reflection loss must be corrected by use of B-factor.

+Signal source greater than 2 from the shield.

++At these frequencies, the fields approach plane waves with an impedance of 377 ohms.

Table 5-5. Shield effectiveness in magnetic field (wave impedance much smaller than 377 ohms) of solid copper, aluminum, and iron shields for signal source 12 inches from the shield at 150 kilohertz to 100 megahertz*

Frequency, MHz	Copper (10 mils)				Aluminum (10 mils)				Iron (10 mils)			
	A (dB)	+	R (dB)	= SE (dB)	A (dB)	+	R (dB)	= SE (dB)	A (dB)	+	R (dB)	= SE (dB)
0.15	13	+	56	= 69	10	+	54	= 64	169	+	19	= 188
1.0	33	+	64	= 97	26	+	62	= 88	363	+	28	= 391
15	129	+	76	= 205	100	+	74	= 174	1060	+	42	= 1102
100	334	+	84	= 418	260	+	82	= 342	1370	+	56	= 1426

*Source: Engineering Design Handbook--Electromagnetic Compatibility, DARCOM-P 706-410 (U.S. Army Materiel Command, March 1977).

EP 1110-3-2
31 Dec 90

Table 5-6. Shielding effectiveness in plane wave field (wave impedance equal to 377 ohms) of solid copper and iron shields for signal sources greater than 2 inches from the shield at 150 kilohertz to 100 megahertz*

Frequency, MHz	Copper (10 mils)					Iron (10 mils)				
	A (dB)	+	R (dB)	=	SE (dB)	A (dB)	+	R (dB)	=	SE (dB)
0.15	13	+	117	=	130	169	+	79	=	248
1.0	33	+	108	=	141	363	+	72	=	435
15.0	129	+	96	=	125	1060	+	63	=	1123
100.0	334	+	88	=	422	1370	+	60	=	1430

*Source: Engineering Design Handbook--Electromagnetic Compatibility,
DARCOM-P 706-410 (U.S. Army Materiel Command, March 1977).

Table 5-7. Shielding effectiveness in electric field (wave impedance much greater than 377 ohms) of solid copper, aluminum, and iron shields for signal source 12 inches from the shield at 0.15 megahertz to 100 megahertz*

Frequency, MHz	Copper (10 mils)			Aluminum (10 mils)			Iron (10 mils)								
	A (dB)	+ R (dB)	= SE (dB)	A (dB)	+ R (dB)	= SE (dB)	A (dB)	+ R (dB)	= SE (dB)						
0.15	13	+	176	=	189	10	+	175	=	185	169	+	139	=	308
1.0	33	+	152	=	185	26	+	150	=	176	363	+	116	=	479
15.0	129	+	116	=	245	100	+	115	=	215	1060	+	83	=	1143
100.0	334	+	92	=	426	260	+	90	=	350	1370	+	64	=	1434

*Source: Engineering Design Handbook--Electromagnetic Compatibility, DARCOM-P 706-410 (U.S. Army Materiel Command, March 1977).

EP 1110-3-2
31 Dec 90

Table 5-8. Re-reflection (B)-factors in electric, magnetic, and plane wave fields of solid copper and iron shields* (sheet 1 of 2)

Shield thickness (mils)	60 Hz	100 Hz	1 kHz	10 kHz	100 kHz	1 MHz
Copper, $\mu = 1$, $g = 1$, magnetic fields						
1	-22.22	-24.31	-28.23	- 9.61	-10.34	-2.6
5	-21.30	-22.07	-15.83	- 6.98	- 0.55	+0.14
10	-19.23	-18.59	-10.37	- 2.62	+ 0.57	0
20	-15.35	-13.77	- 5.41	+ 0.13	- 0.10	-
30	-12.55	-10.76	- 2.94	+ 0.58	0	-
50	- 8.88	- 7.07	- 0.58	0	-	-
100	- 4.24	- 2.74	+ 0.50	-	-	-
200	- 0.76	+ 0.05	0	-	-	-
300	+ 0.32	+ 0.53	-	-	-	-
Copper, $\mu = 1$, $g = 1$, electric fields and plane waves						
1	-41.52	-39.31	-29.38	-19.61	-10.33	-2.61
5	-27.64	-25.46	-15.82	- 6.96	- 0.55	+0.14
10	-21.75	-19.61	-10.33	- 2.61	+ 0.57	0
20	-15.99	-13.92	- 5.37	+ 0.14	- 0.10	-
30	-12.73	-10.73	- 2.90	+ 0.58	0	-
50	- 8.81	- 6.96	- 0.55	+ 0.14	-	-
100	- 4.08	- 2.61	+ 0.51	0	-	-
200	- 0.62	+ 0.14	0	-	-	-
300	+ 0.41	+ 0.58	-	-	-	-
Iron, $\mu = 100$, $g = 0.17$, magnetic fields						
1	+ 0.95	+ 1.23	- 1.60	- 1.83	-	-
5	+ 0.93	+ 0.89	- 0.59	0	-	-
10	+ 0.78	+ 0.48	+ 0.06	-	-	-
20	+ 0.35	+ 0.08	0	-	-	-
30	+ 0.06	- 0.06	-	-	-	-
50	0	0	-	-	-	-

EP 1110-3-2

31 Dec 90

Table 5-8. Re-reflection (B)-factors in electric, magnetic, and plane wave fields of solid copper and iron shields* (sheet 2 of 2)

Shield thickness (mils)	60 Hz	100 Hz	1 kHz	10 kHz	100 kHz	1 MHz
Iron, $\mu = 1000$, $g = 0.17$, electric fields and plane waves						
1	-19.53	-17.41	- 8.35	- 1.31	-	-
5	- 6.90	- 5.17	+ 0.20	0	-	-
10	- 2.56	- 1.31	+ 0.36	-	-	-
20	+ 0.16	+ 0.54	0	-	-	-
30	+ 0.58	+ 0.42	-	-	-	-
50	+ 0.13	0	-	-	-	-

*Source: Engineering Design Handbook--Electromagnetic Compatibility, DARCOM-P 706-410 (U.S. Army Materiel Command, March 1977).

EP 1110-3-2
31 Dec 90

Table 5-9. Shielding effectiveness in electric, magnetic, and plane wave fields of copper shield (7 mils thick) for signal source 165 feet from the shield at 30 hertz to 10 gigahertz*

Frequency	Plane wave, dB	Electric field, dB	Magnetic field, dB
30 Hz	122	213	32
60 Hz	122	207	39
100 Hz	122	202	42
500 Hz	123	189	57
1 kHz	123	183	63
10 kHz	123	163	83
50 kHz	123	149	98
150 kHz	124	140	108
1 MHz	131	--	--
3 MHz	144	--	--
10 MHz	172	--	--
15 MHz	187	--	--
100 MHz	322	--	--
1000 MHz	818	--	--
1500 MHz	981	--	--
10 GHz	2408	--	--

*Source: Engineering Design Handbook--Electromagnetic Compatibility, DARCOM-P 706-410 (U.S. Army Materiel Command, March 1977).

EF 1110-3-2
31 Dec 90

Table 5-10. Shielding effectiveness in electric, magnetic, and plane wave fields of steel shield (1 mil thick) for signal source 165 feet from the shield at 30 hertz to 10 gigahertz*

Frequency	Plane wave, dB	Electric field, dB	Magnetic field, dB
30 Hz	85	175	4
60 Hz	86	171	6
100 Hz	86	166	10
500 Hz	86	152	21
1 kHz	86	146	26
10 kHz	86	125	46
50 kHz	87	113	61
150 kHz	89	105	73
1 MHz	98	--	--
3 MHz	110	--	--
10 MHz	136	--	--
15 MHz	142	--	--
100 MHz	164	--	--
1000 MHz	287	--	--
1500 MHz	186	--	--
10 GHz	164	--	--

*Source: Engineering Design Handbook--Electromagnetic Compatibility, DARCOM-P 706-410 (U.S. Army Materiel Command, March 1977).

EP 1110-3-2
31 Dec 90

Table 5-11. Shielding effectiveness in electric, magnetic, and plane wave fields of steel shield (50 mils thick) for signal source 165 feet from the shield at 30 hertz to 10 gigahertz*

Frequency	Plane wave, dB	Electric field, dB	Magnetic field, dB
30 Hz	121	211	31
60 Hz	123	208	39
100 Hz	125	205	46
500 Hz	138	204	73
1 kHz	151	211	91
10 kHz	249	289	210
50 kHz	455	481	430
150 kHz	725	741	709
1 MHz	1465	--	--
3 MHz	2311	--	--
10 MHz	3801	--	--
15 MHz	4140	--	--
100 MHz	5338	--	--
1000 MHz	11,850	--	--
1500 MHz	6547	--	--
10 GHz	5338	--	--

*Source: Engineering Design Handbook--Electromagnetic Compatibility, DARCOM-P 706-410 (U.S. Army Materiel Command, March 1977).

EP 1110-3-2
31 Dec 90

Table 5-12. Sample calculations of shielding effectiveness for solid metal shield* (sheet 1 of 2)

10 kHz-10 mils						
	<u>Magnetic field</u>		<u>Electric field</u>		<u>Plane wave</u>	
	<u>Copper</u>	<u>Iron</u>	<u>Copper</u>	<u>Iron</u>	<u>Copper</u>	<u>Iron</u>
Reflection	44.2	8.0	212.0	174.0	128.0	90.5
Absorption	3.6	43.5	3.3	43.5	3.3	43.5
B-factor	-2.6	0	-2.6	0	-2.6	0
Total loss (dB)	45.2	51.5	212.7	217.5	128.7	134.0

60 Hz-magnetic						
	<u>1 mil</u>		<u>10 mils</u>		<u>300 mils</u>	
	<u>Copper</u>	<u>Iron</u>	<u>Copper</u>	<u>Iron</u>	<u>Copper</u>	<u>Iron</u>
Reflection	22.4	-0.9	22.4	-0.9	22.4	-0.9
Absorption	0.03	0.33	0.26	3.34	7.80	100.0
B-factor	-22.2	+0.95	-19.2	+0.78	+0.32	0
Total loss (dB)	0.23	0.38	3.46	3.22	30.52	99.1

<u>10 kHz - 30 mils - magnetic</u>				<u>1 kHz - 10 mils - magnetic</u>	
	<u>Copper</u>	<u>Iron</u>		<u>Copper</u>	<u>Iron</u>
	Reflection	44.20		8.0	
Absorption	10.02	130.5		1.06	13.70
B-factor	+0.58	0		-10.37	+0.06
Total loss (dB)	54.80	138.5		24.89	14.66

EP 1110-3-2
31 Dec 90

Table 5-12. Sample calculations of shielding effectiveness for solid metal shield* (sheet 2 of 2)

	10 mils-copper					
	150 kHz			1 MHz		
	Electric	Plane waves	Magnetic	Electric	Plane waves	Magnetic
Reflection	176.8	117.0	56.0	152.0	108.2	64.2
Absorption	12.9	12.9	12.9	33.4	33.4	33.4
B-factor	+0.5	+0.5	+0.5	0	0	0
Total loss (dB)	190.2	130.4	69.4	185.4	141.6	97.6

*Source: Engineering Design Handbook--Electromagnetic Compatibility, DARCOM-P-706-410 (U.S. Army Materiel Command, March 1977).

EP 1110-3-2
31 Dec 90

Table 5-13. Peak voltage induced on 10-meter radius loop inside 10-meter radius spherical shield by the high-altitude EMP (by diffusion through the walls only)*

Shield thickness, mm	Internal voltage induced in loop		
	Copper (5.8×10^7 mho/m)	Aluminum (3.7×10^7 mho/m) $\mu_r = 200$	Steel (6×10^6 mho/m)
0.2	0.34 V	0.85 V	0.076 V
1.0	2.6 mV	6.4 mV	1.1 mV
5.0	21 μ V	51 μ V	15 μ V

*Source: E. F. Vance, "Electromagnetic Interference Control," IEEE Transactions on Electromagnetic Compatibility, Vol EMC-22 (Institute for Electrical and Electronic Engineers, November 1980).

Table 5-14. Effectiveness of nonsolid shielding materials against low-impedance and plane waves*

Impinging wave	General	Form Detail	Material	Thickness, mils	Nominal effectiveness, dB					
					0.1 kHz	1 kHz	10 kHz	85 kHz	1 MHz	10 MHz
Low impedance	Mesh (screening)	2 layers 1 in. apart	Cu (oxidized)	--	2	6	18	--	--	--
			No. 22 Cu	--	--	--	31	43	43	
			No. 16 Bronze	--	--	--	18	--	--	
			No. 4 Galvan- ized steel	--	--	--	10	17	21	
Plane	Perforated sheet	45-mil diam 225 sq in.	Al	20	<u>3040 MHz</u>		<u>9380 MHz</u>			
					60	62				
Plane					<u>200 kHz</u>	<u>1 MHz</u>	<u>5 MHz</u>	<u>100 MHz</u>		
	Mesh (screening)	No. 16	Al	diam = 13	34	36	--	--		
		No. 22	Cu	diam = 15	118	106	100	80		

*Source: Electromagnetic Compatibility Design Guide for Avionics and Related Ground Support Equipment, NAVAIR AD1115 (U.S. Department of the Navy, Naval Air Systems Command).

Table 5-15. Effectiveness of nonsolid shielding materials against high-impedance waves*

General	Form		Material	Thickness, mils	Nominal effectiveness (14 kHz to 1000 MHz),		Open area, in. of water / 200 cu ft/min	Air-flow static pressure, in. of water / 400 cu ft/min	Air-flow static pressure,
	General	Detailed			dB	%			
Hexcell		1/4-in. cell, 1-in. thick	Al	3	>90		--	0.06	0.26
TV shadow mask (photo-etched)		9-mil holes, 28-mil centers	95% Cu	7	>90		12	>2	--
			5% Zn	7	>90		50	0.2	--
			100% Cu	3	>90			0.2	--
Lektromesh		40 count	Cu-Mi	7	>90		36	0.4	1.7
		25 count	Cu-Mi	5	78		49	0.2	0.5
		40 count	Cu	3	78		57	0.2	0.5
		25 count	Cu				56	0.2	0.4
Perforated sheet		1/8-in. diam 3/16-in. centers	Steel	60	58			0.27	>0.6
		1/4-in. diam, 5/16-in. centers	Al	60	48		46	--	--
		7/16-in. diam, 5/8-in. centers	Al	37	35		45	--	--
Mesh (screening)		No. 16 16 x 16/sq in.	Al	20 (diam)	55		36	--	--
		No. 22	Cu		65 (14 kHz - 60 MHz)				
		No. 12	Cu	20 (diam)	50		50	--	--
		No. 16	Bronze		45 (14 kHz - 60 MHz)				
		No. 10	Monel	18 (diam)	40				
		No. 4	Galvanized steel	30 (diam)	35		76	--	--
	No. 2			28 (14 kHz - MHz)		88	--	--	

*Source: R. B. Schultz, et al., "Shielding Theory and Practice," Proceedings of the Tri-Service Conference on Electromagnetic Compatibility (IITRI, October 1973).

EP 1110-3-2
31 Dec 90

Table 5-16. Comparison of measured and calculated values of shielding effectiveness for No. 22, 15-mil copper screens*

Test type	Frequency, MHz	Measured effectiveness, dB	Calculated effectiveness, dB
Magnetic field (r = 1.75 in.)	0.085	31	29
	1.000	43	46
	10.000	43	49
Plane wave	0.200	118	124
	1.000	106	110
	5.000	100	95
	100.000	80	70
Electric field	0.014	65	65

*Source: W. Jarva, "Shielding Efficiency Calculation Methods for Screening, Waveguide Ventilation Panels, and Other Perforated Electromagnetic Shields," Proceedings of the Seventh Conference on Radio Interference Reduction and Electromagnetic Compatibility (IITRI, November 1961).

EP 1110-3-2
31 Dec 90

Table 5-17. Attenuation factors for reinforcement steel construction*

Bar diameter, cm	Bar spacing, cm	Type of construction	Attenuation decrement, Δ dB
5.8	30	Single-course	+5
4.3	35	Single-course	0
2.5	45	Single-course	-6
5.8	50	Double-course	+8.5
4.3	35	Double-course	+13
2.5	40	Double-course	+5

*Source: EMP Engineering Practices Handbook, NATO File No. 1460-2 (October 1977).

EP 1110-3-2
31 Dec 90

Table 5-18. Application factors for welded wire fabric*

Wire diameter, mm	Spacing, cm	Number of courses	Attenuation increment, dB
3	20	1	-3
3	20	2	+4

*Source: EMP Engineering Practices Handbook, NATO File No. 1460-2 (October 1977).

Table 5-19. Typical values of conductivity for soils and rock*

Electrical conductivity, mho/meter	Geological period and rock type				
	Quaternary	Quaternary tertiary cretaceous	Jurassic triassic carboniferous	Devonian silurian ordovician cambrian	Cambrian precambrian
1×10^{-1}	Shallow playa deposits	Loam, clay	--	--	--
3×10^{-2}		Chalk	Chalk, trap	--	--
1×10^{-2}		Alluvium	Alt. basalt, shale	--	--
3×10^{-3}			Limestone, sandstone	Shale, limestone	--
1×10^{-3}				Sandstone, dolomite	Sandstone
3×10^{-4} to 1×10^{-4}	Coarse sand and gravel in surface layers	--	--	--	Quartzite, slate, granite, gneiss

*Source: EMP Engineering Practices Handbook, NATO File No. 1460-2 (October 1977).

68-5

EP 1110-3-2
31 Dec 90

EP 1110-3-2
31 Dec 90

Table 5-20. Skin depth (δ) and absorption loss (A) for nonmetal materials*

Frequency	Water content (%)					
	1		10		50	
	δ (m)	A(dB/m)	δ (m)	A(dB/m)	δ (m)	A(dB/m)
1 kHz	950	0	172	0.1	50	0.2
10 kHz	280	0	53	0.2	16	0.5
100 kHz	80	0.1	16	0.5	5	1.7
300 kHz	40	0.2	9	0.9	2.8	3.0
1 MHz	18	0.5	4.9	1.8	1.5	5.6
3 MHz	8.7	1.0	2.7	3.2	0.87	9.9
10 MHz	3.5	2.5	1.3	6.7	0.46	18.7
100 MHz	0.56	15.6	0.28	31.2	0.12	68.5

*Source: EMP Engineering Practices Handbook, NATO File No. 1460-2 (October 1977). Calculated using infinite-plane geometry.

EP 1110-3-2
31 Dec 90

Table 5-21. Electromotive series

Element	Volts	Ion	Element	Volts	Ion
Lithium	2.9595		Tin	0.136	
Rubidium	2.9259		Lead	0.122	Pb ⁺⁺
Potassium	2.9241		Iron	0.045	Fe ⁺⁺⁺
Strontium	2.92		Hydrogen	0.000	
Barium	2.90		Antimony	-0.10	
Calcium	2.87		Bismuth	-0.226	
Sodium	2.7146		Arsenic	-0.30	
Magnesium	2.40		Copper	-0.344	Cu ⁺⁺
Aluminum	1.70		Oxygen	-0.397	
Beryllium	1.69		Polonium	-0.40	
Uranium	1.40		Copper	-0.470	Cu ⁺
Manganese	1.10		Iodine	-0.5345	
Tellurium	0.827		Tellurium	-0.558	Te ⁺⁺⁺⁺
Zinc	0.7618		Silver	-0.7978	
Chromium	0.557		Mercury	-0.7986	
Sulfur	0.51		Lead	-0.80	Pb ⁺⁺⁺⁺
Gallium	0.50		Palladium	-0.820	
Iron	0.441	Fe ⁺⁺	Platinum	-0.863	
Cadmium	0.401		Bromine	-1.0648	
Indium	0.336		Chlorine	-1.3583	
Thallium	0.330		Gold	-1.360	Au ⁺⁺⁺⁺
Cobalt	0.278		Gold	-1.50	Au ⁺
Nickel	0.231		Fluorine	-1.90	

EP 1110-3-2
31 Dec 90

Table 5-22. Characteristics of conductive gasketing materials*

Material	Chief advantages	Chief limitations
Compressed knitted wire	Most resilient all-metal gasket (low flange pressure required). Most points of contact. Available in variety of thicknesses and resiliencies, and in combination with neoprene and silicone.	Not available in sheet (certain intricate shapes difficult to make). Must be 0.040 in. or thicker. Subject to compression set.
Brass or beryllium copper with punctured nail holes	Best breakthrough of corrosion protection films.	Not truly resilient or generally reusable.
Oriented wires in rubber silicone	Combines fluid and RF seal. Can be effective against corrosion films if ends of wires are sharp.	Might require wider or thicker size gasket for same effectiveness. Effectiveness declines with mechanical use.
Aluminum screen impregnated with neoprene	Combines fluid and conductive seal. Thinnest gasket. Can be cut to intricate shapes.	Very low resiliency (high flange pressure required).
Soft metals	Cheapest in small sizes.	Cold flows, low resiliency.
Metal over rubber	Takes advantage of the resiliency of rubber.	Foil cracks or shifts position. Generally low insertion loss yielding poor RF properties.
Conductive rubber (carbon-filled)	Combines fluid and conductive seal.	Provides moderate insertion loss.
Conductive rubber (silver-filled)	Combines fluid and RF seal. Excellent resiliency with low compression set. Reusable. Available in any shape or cross section.	Not as effective as metal in magnetic fields. May require salt spray environmental protection.
Contact fingers	Best suited for sliding contact.	Easily damaged. Few points of contact.

*Source: MIL-HDBK-335 (USAF), Management and Design Guidance, Electromagnetic Radiation Hardness for Air Launched Ordnance Systems (DOD, 15 January 1981).

EP 1110-3-2
31 Dec 90

This page not used.

Table 5-24. Comparison of protection devices

Device type	Clamping (or filtering) thresholds	Operate time, sec	Highest burnout-energy thresholds, J	Shunt capacitance F	Typical circuit applications	Possible disadvantages
Varistors						
MOV	40-1500 V	$<10^{-9}$	$<10^3$	10^{-9}	Power, AP	High capacitance
SiC	15-10,000 V	$<10^{-9}$	$<10^5$	$<10^{-9}$	Power, term.	Poor clamping
Semiconductors						
Forward diodes (Si, Ge)	0.2-0.6 V	$<10^{-9}$	$<10^1$	$<10^{-12}$	AP, RP	Low burnout energy
Breakdown diodes (Si, Ge)	2-200 V	$<10^{-9}$	$<10^2$	$<10^{-8}$	Power, AP	High capacitance
Selenium-diode packages	30-2000 V	$<10^{-9}$	$<10^4$	$<10^{-7}$	Power	High capacitance
Diode thyristors (p-n-p-n)	25-1800 V	$<10^{-6}$	$<10^1$	$<10^{-6}$	AP	Latch-up, di/dt burnout, slow response, high capacitance
Triggered thyristors (SCRs)	25-1800 V	$<10^{-5}$	$<10^1$	$<10^{-6}$	AP, alarm	Latch-up, di/dt burnout, slow response, high capacitance
Spark gaps						
Carbon blocks	330-800 V	$<10^{-6}$	$<10^4$	$<10^{-11}$	Term., AP, RP	Power-follow, slow response
Ordinary gas tubes	60-30,000	$<10^{-5}$	$<10^6$	$<10^{-11}$	Term., AP, RP	Power-follow, slow response, high cost
High-speed gaps	550-20,000	$<10^{-9}$	$<10^3$	$<10^{-11}$	Term., AP, RP	Power-follow, high cost
Ordinary arresters	60-30,000 V	$<10^{-5}$	$<10^3$	$<10^{-11}$	Power	Slow response, high cost
Arresters using high-speed gaps	550-20,000 V	$<10^{-9}$	$<10^3$	$<10^{-11}$	Power	High cost

5-94

EP 1110-3-2
31 Dec 90

EP 1110-3-2
31 Dec 90

Table 5-25. Galvanic series for selected metals

Corroded end (anodic, or least noble)	Nickel (active) Inconel (active)
Magnesium	Brasses
Magnesium alloys	Copper
Zinc	Bronzes
Aluminum 2S	Copper-nickel alloys
Cadmium	Monel
Aluminum 17ST	Silver solder
Steel or iron	Nickel (passive)
Cast iron	Inconel (passive)
Chromium-iron (active)	Chromium-iron (passive)
Ni-Resist	18-8 Stainless (passive)
18-8 Stainless (active)	18-8-3 Stainless (passive)
18-8-3 Stainless (active)	Silver
Lead-tin solders	Graphite
Lead	Gold
Tin	Platinum
	Protected end (cathodic, or most noble)

EP 1110-3-2
31 Dec 90

Table 5-26. Relative advantages and disadvantages of the principal types of earth electrodes

Type	Advantages	Disadvantages
Vertical rods	Straightforward design. Easiest to install (particularly around an existing facility). Hardware readily available. Can be extended to reach water table.	High impulse impedance. Not useful where large rock formations are near surface. Step voltage on earth surface can be excessive under high fault currents or during direct lightning strike.
Horizontal grid	Minimum surface potential gradient. Straightforward installation if done before construction. Can achieve low resistance contact in areas where rock formations prevent use of vertical rods. Can be combined with vertical rods to stabilize resistance fluctuations.	Subject to resistance fluctuation with soil drying if vertical rods not used.
Plates	Can achieve low resistance contact in limited area.	Most difficult to install.
Horizontal wires	Can achieve low resistance where rock formations prevent use of vertical rods. Low impulse impedance. Good RD counterpoise when laid in star pattern.	Subject to resistance fluctuations with soil drying.
Incidental electrodes (utility pipes, building foundations, buried tanks)	Can exhibit very low resistance if electrically continuous. Generally lowest initial cost (borne by others).	Little or no control over future alterations.

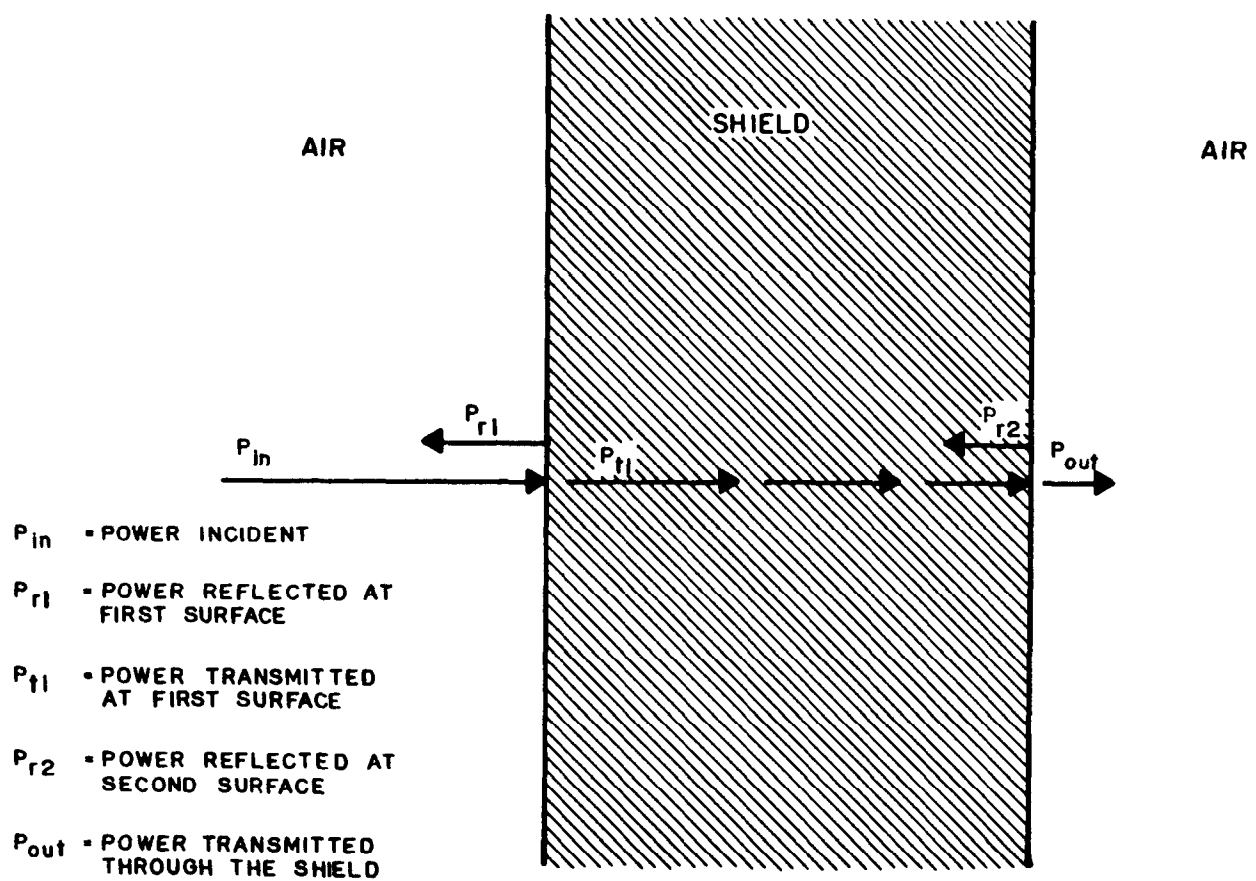
EP 1110-3-2
31 Dec 90

Figure 5-1. Transmission line model of shielding. (Source: ref 5-6)

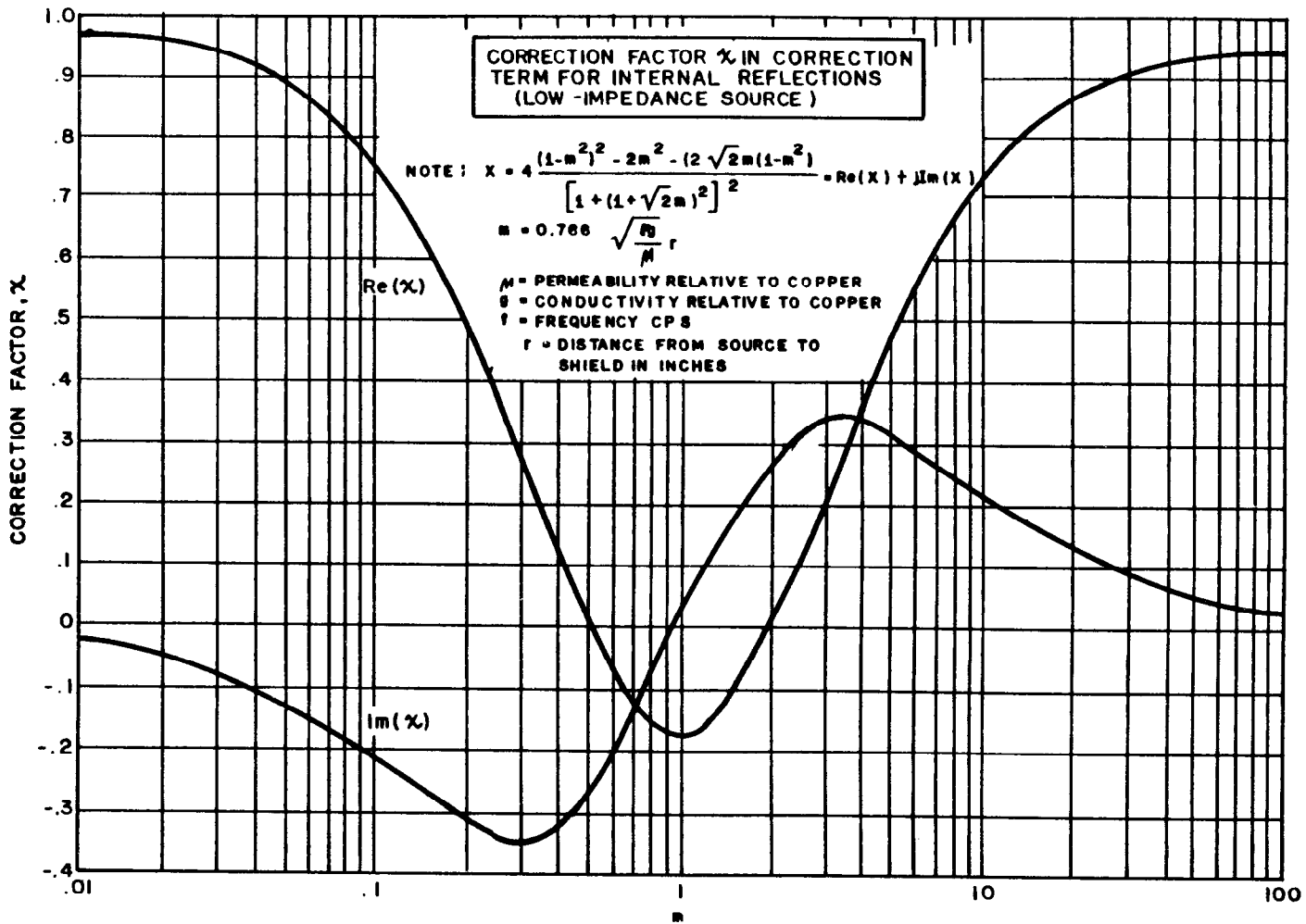


Figure 5-2. Correction factor in correction term for internal reflections.
 (Source: ref 5-3)

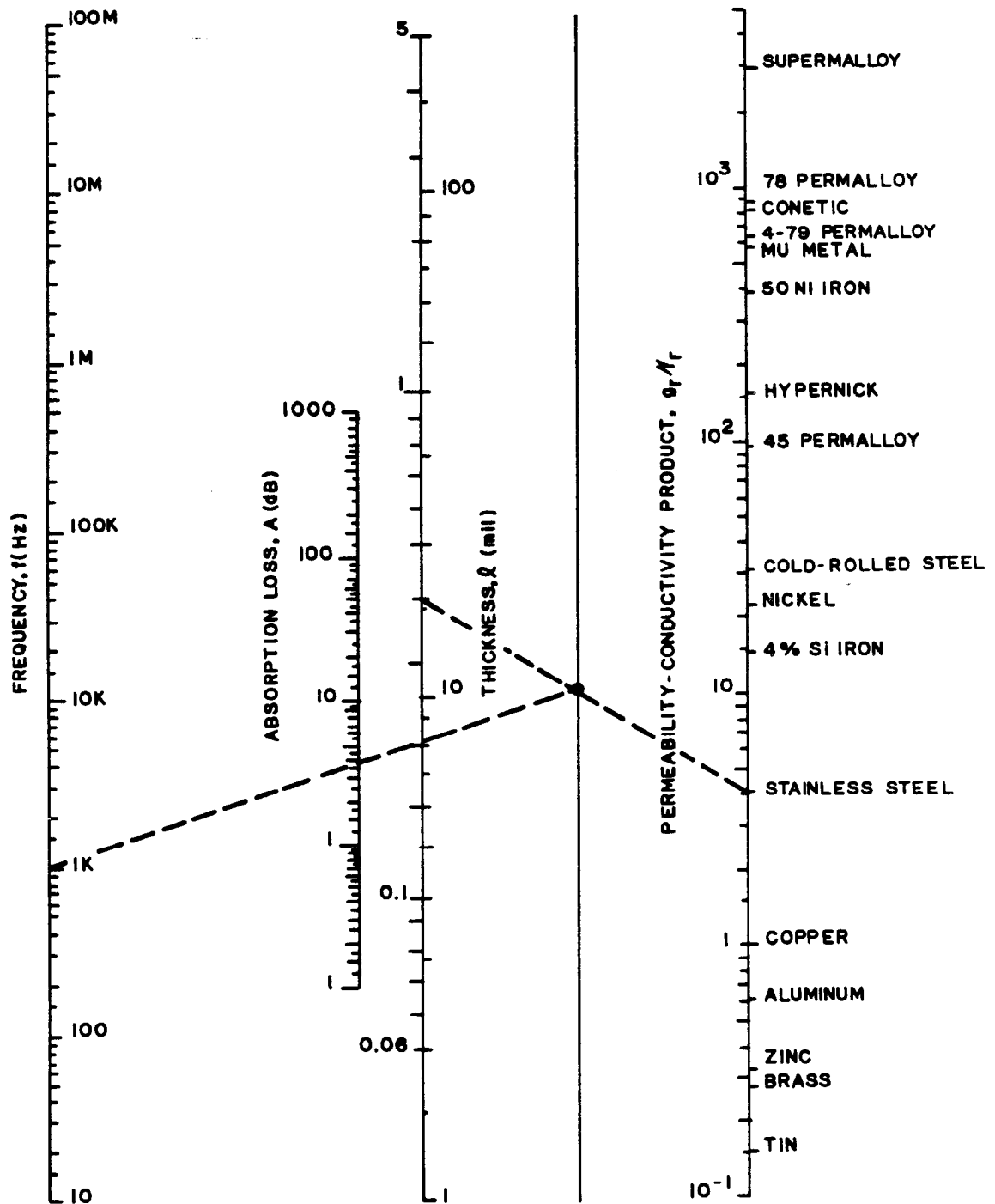
EP 1110-3-2
31 Dec 90

Figure 5-3. Shield absorption loss nomograph. (Source: ref 5-6)

EP 1110-3-2
31 Dec 90

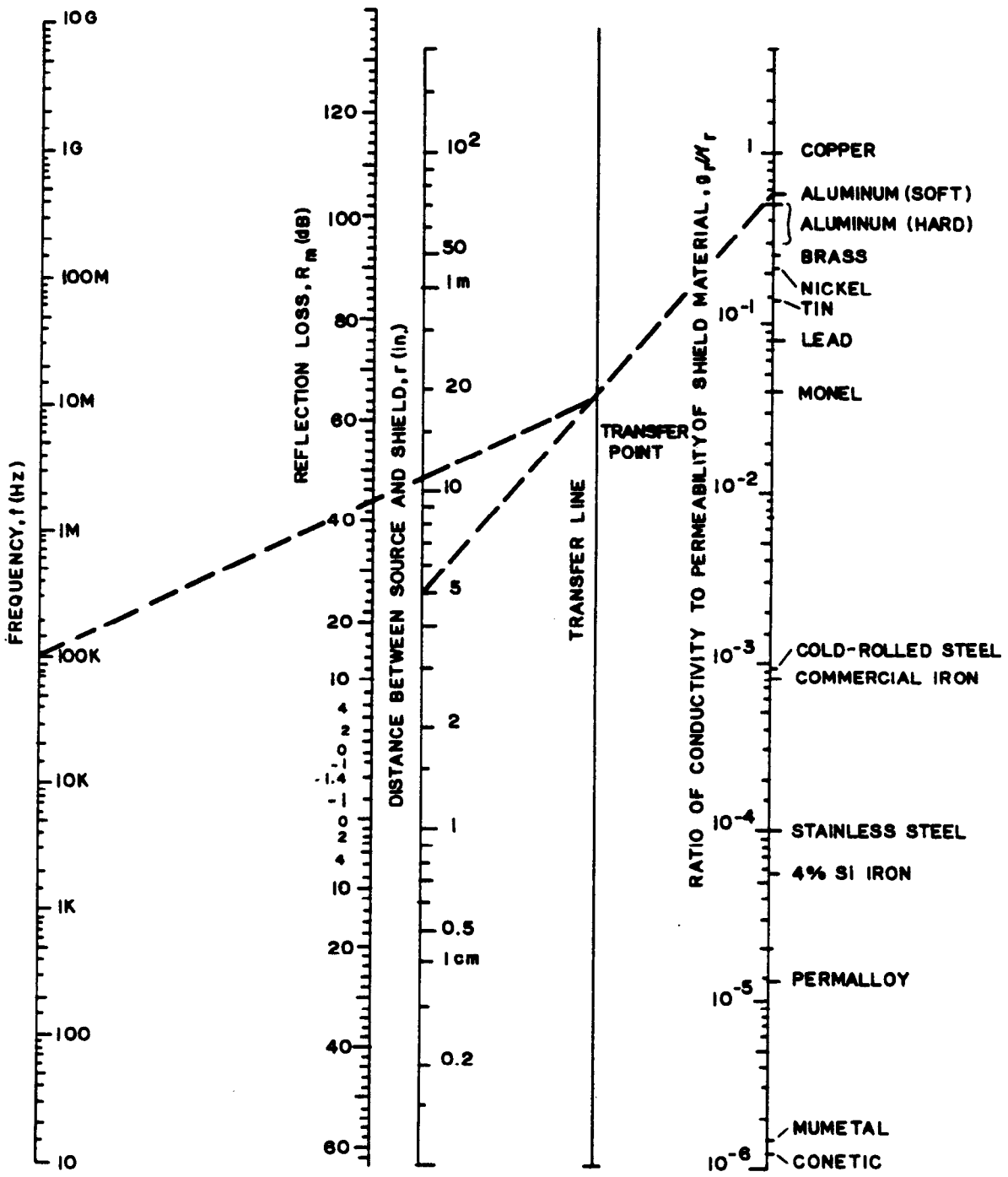


Figure 5-4. Nomograph for determining magnetic field reflection loss.
(Source: ref 5-6)

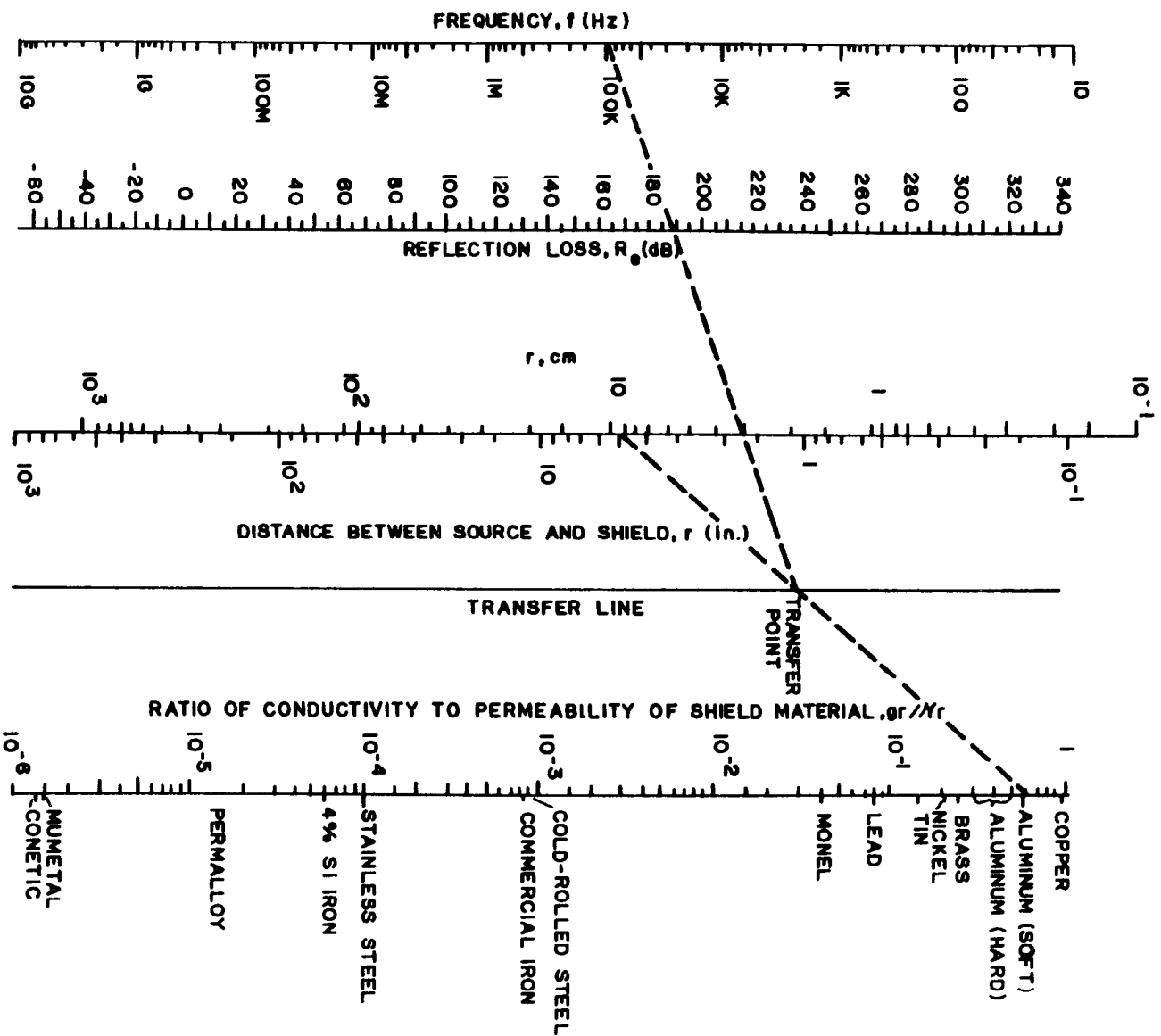


Figure 5-5. Nomograph for determining electric field reflection loss.
 (Source: ref 5-3)

EP 1110-3-2
31 Dec 90

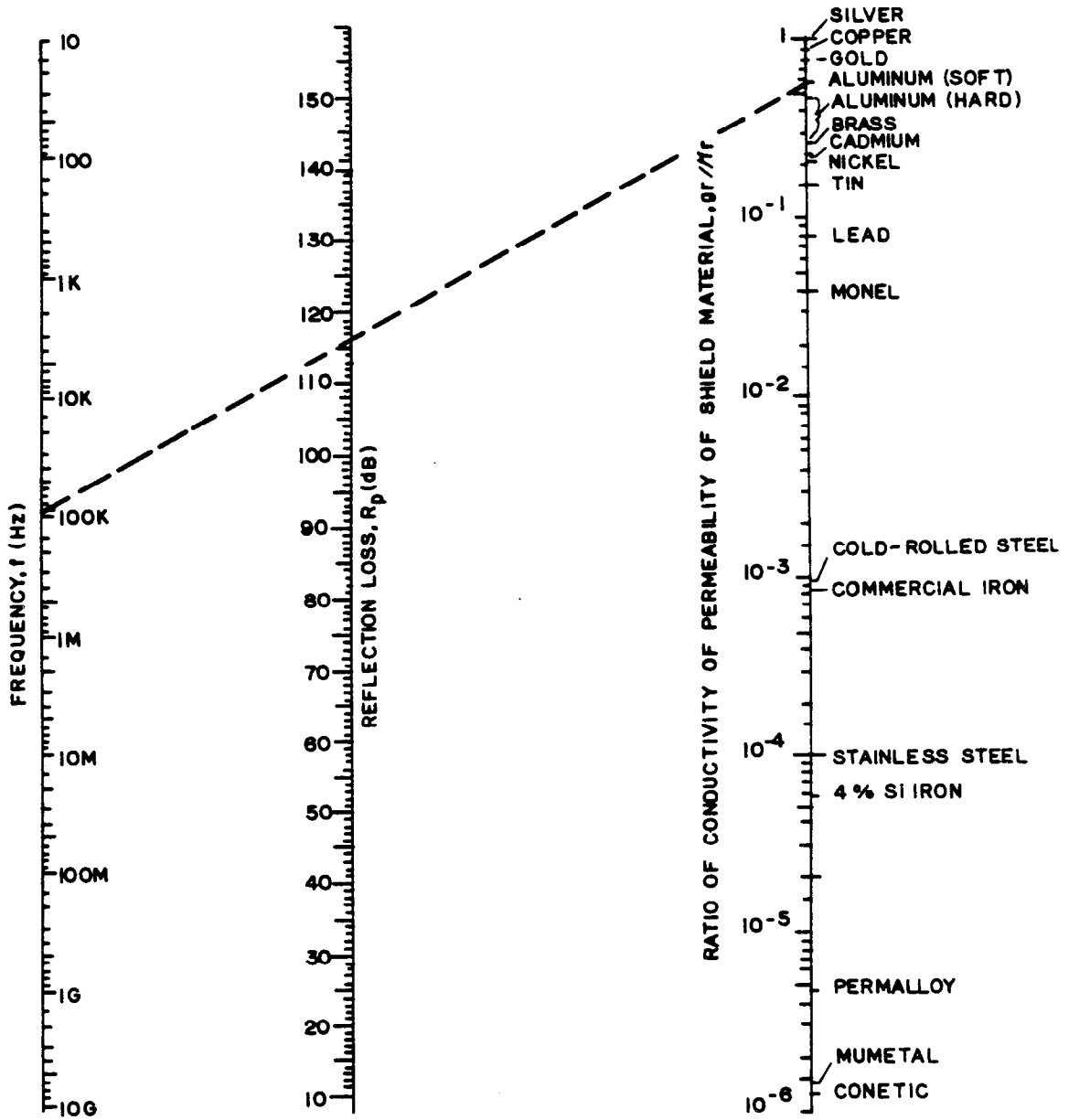


Figure 5-6. Nomograph for determining plane wave reflection loss.
(Source: ref 5-3)

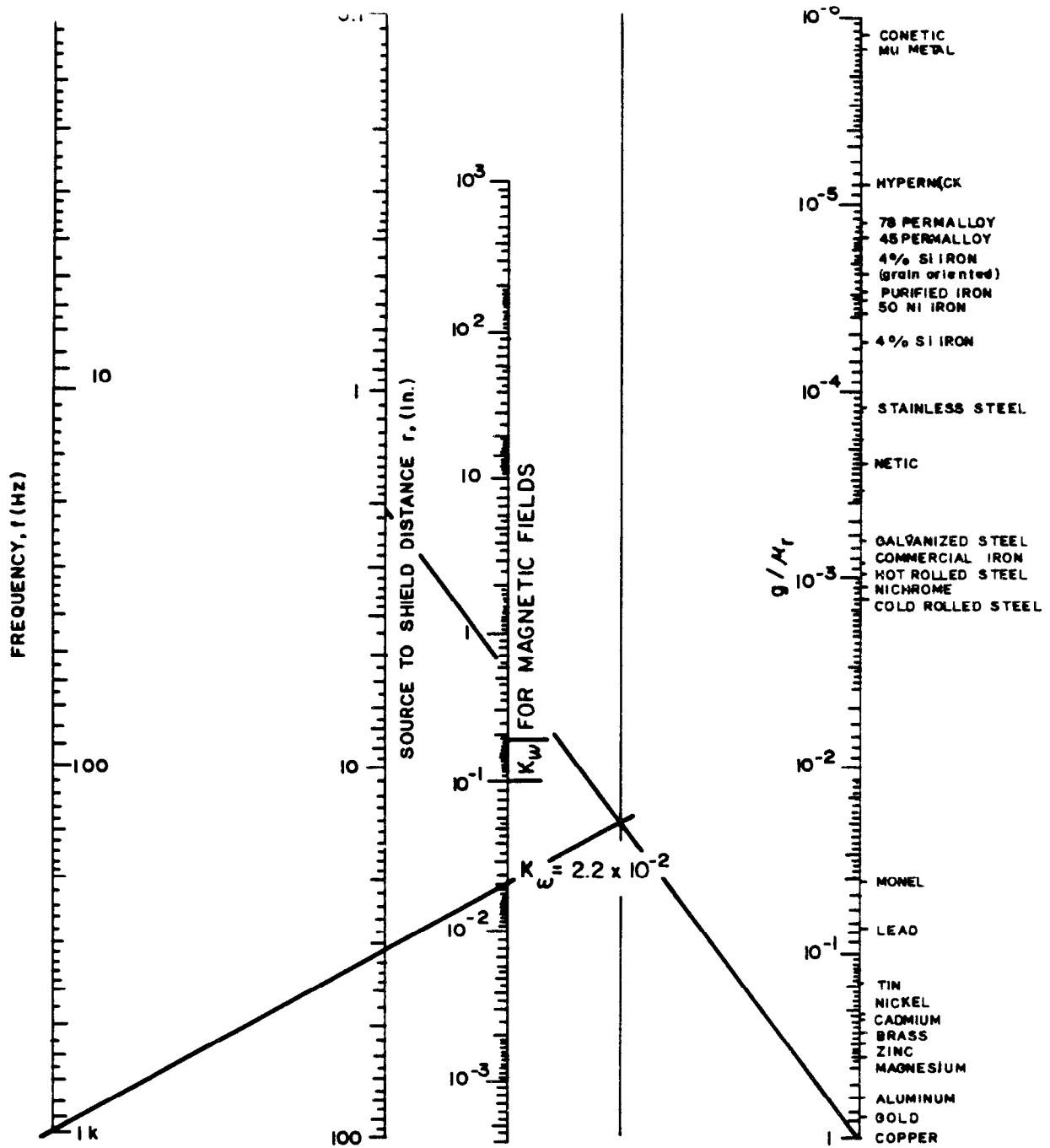


Figure 5-7. Chart for computing K for magnetic field secondary reflection loss. (Source: ref 5-3)

EP 1110-3-2
31 Dec 90

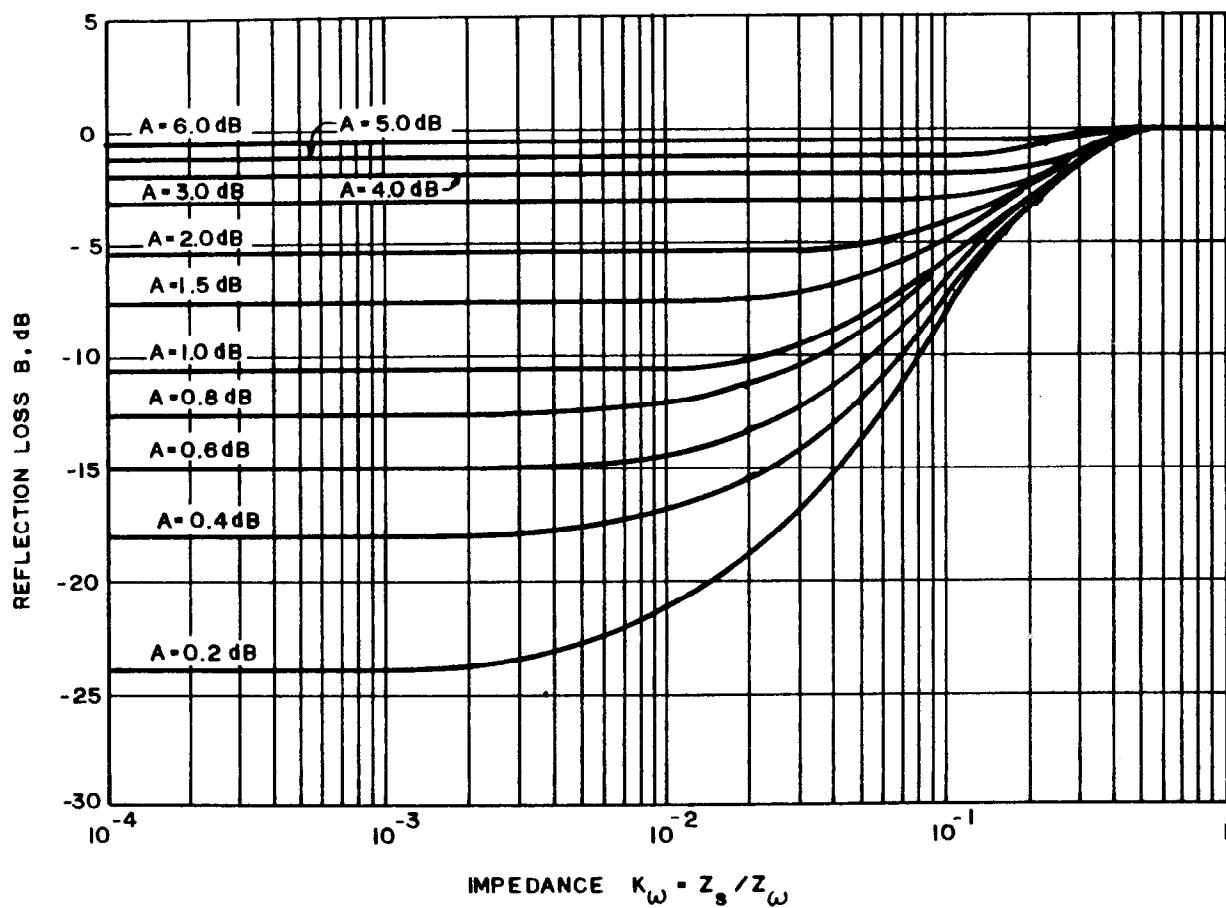


Figure 5-8. Chart for computing secondary losses for magnetic fields.
(Source: ref 5-3)

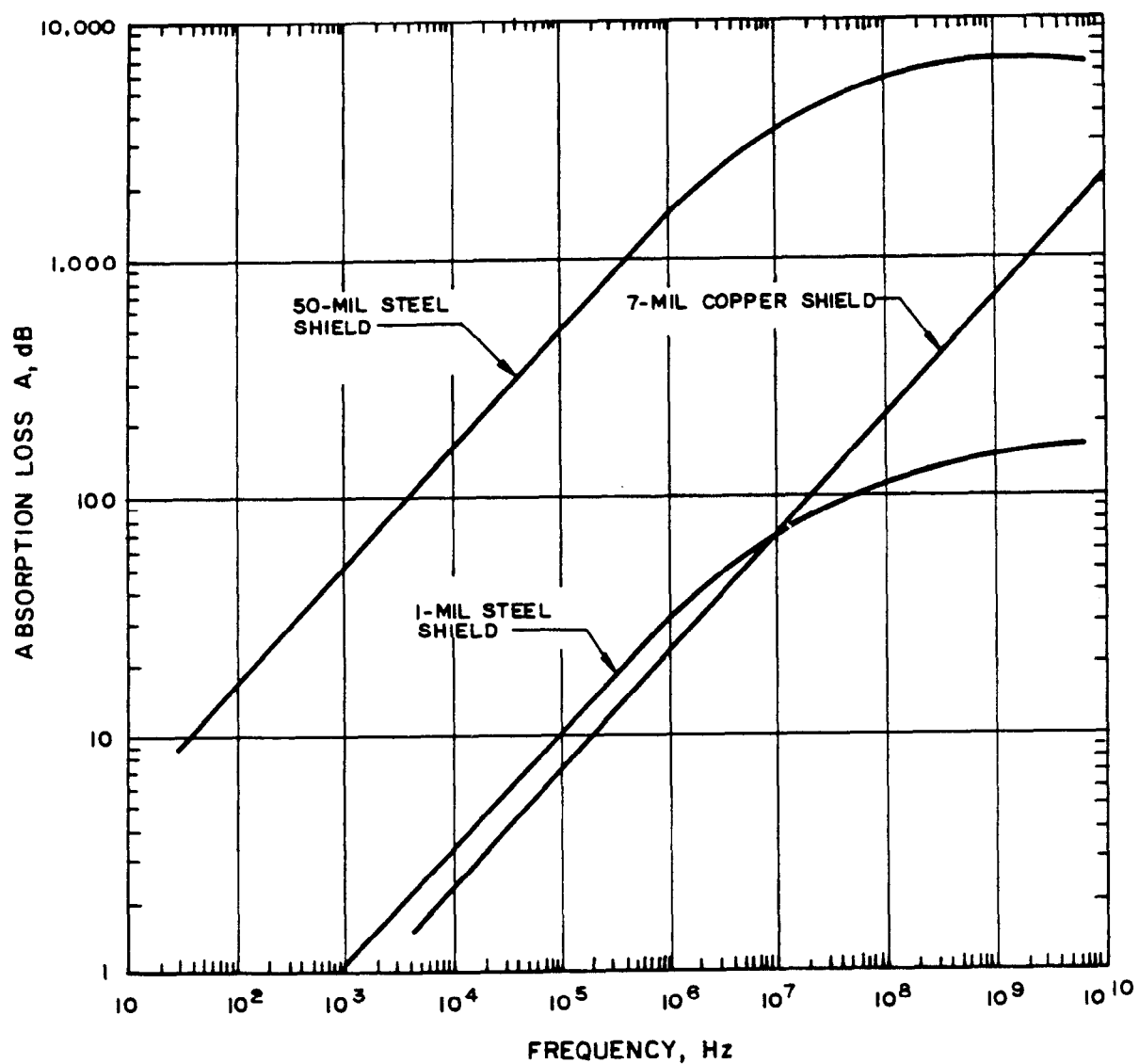


Figure 5-9. Absorption loss for steel and copper shields at 30 hertz to 10,000 megahertz. (Source: ref 5-3)

EP 1110-3-2
31 Dec 90

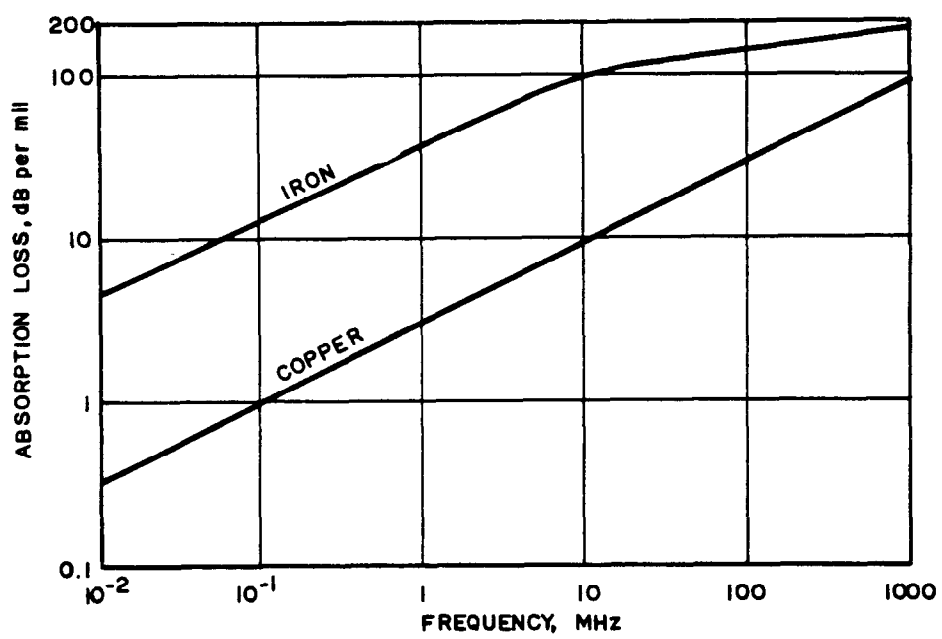


Figure 5-10. Absorption loss for copper and iron, in decibels per mil.
(Source: ref 5-3)

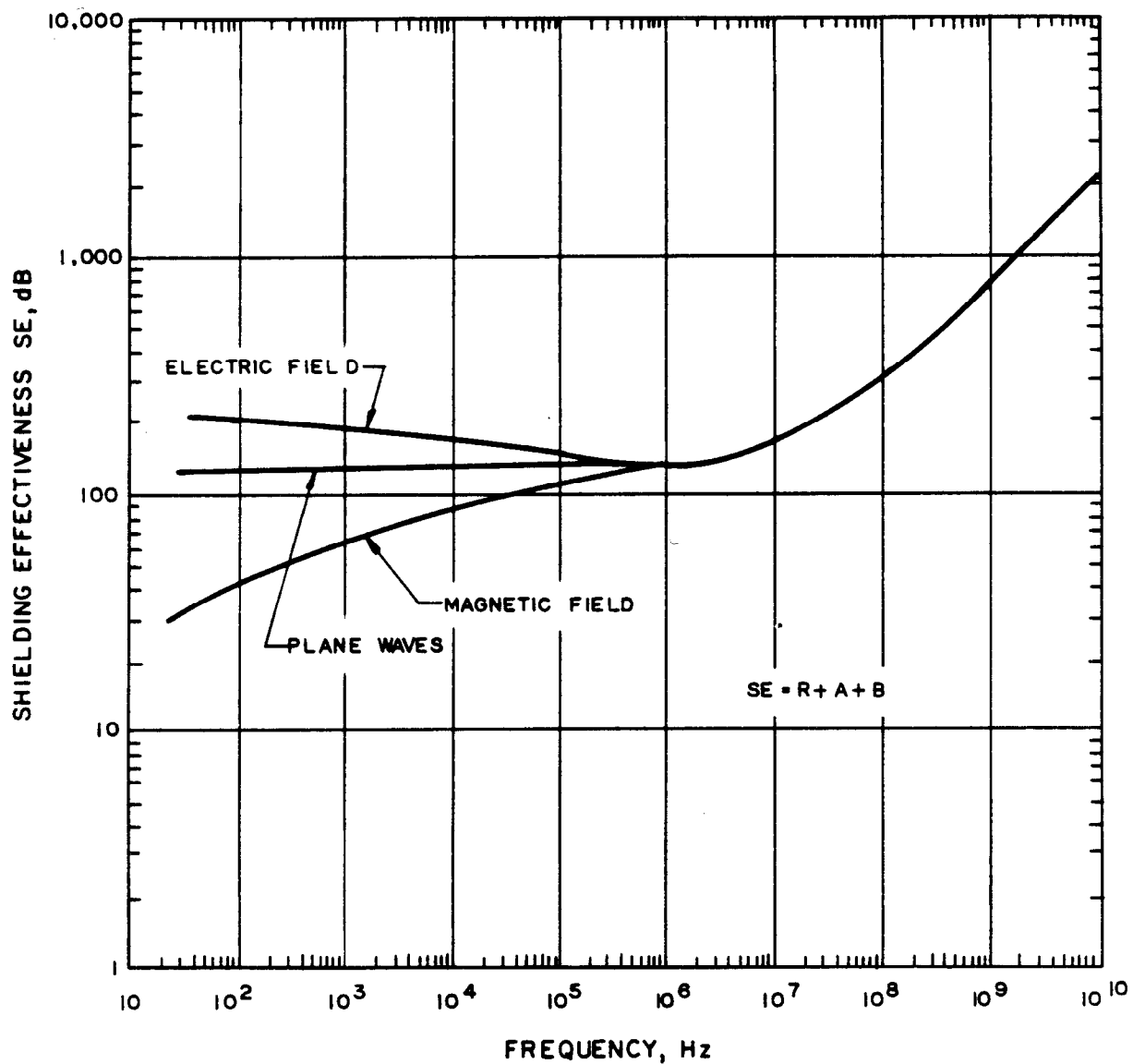
EP 1110-3-2
31 Dec 90

Figure 5-11. Shielding effectiveness in electric, magnetic, and plane wave fields of copper shields (7 mils thick) for signal source 165 feet from the shield. (Source: ref 5-3)

EP 1110-3-2
31 Dec 90

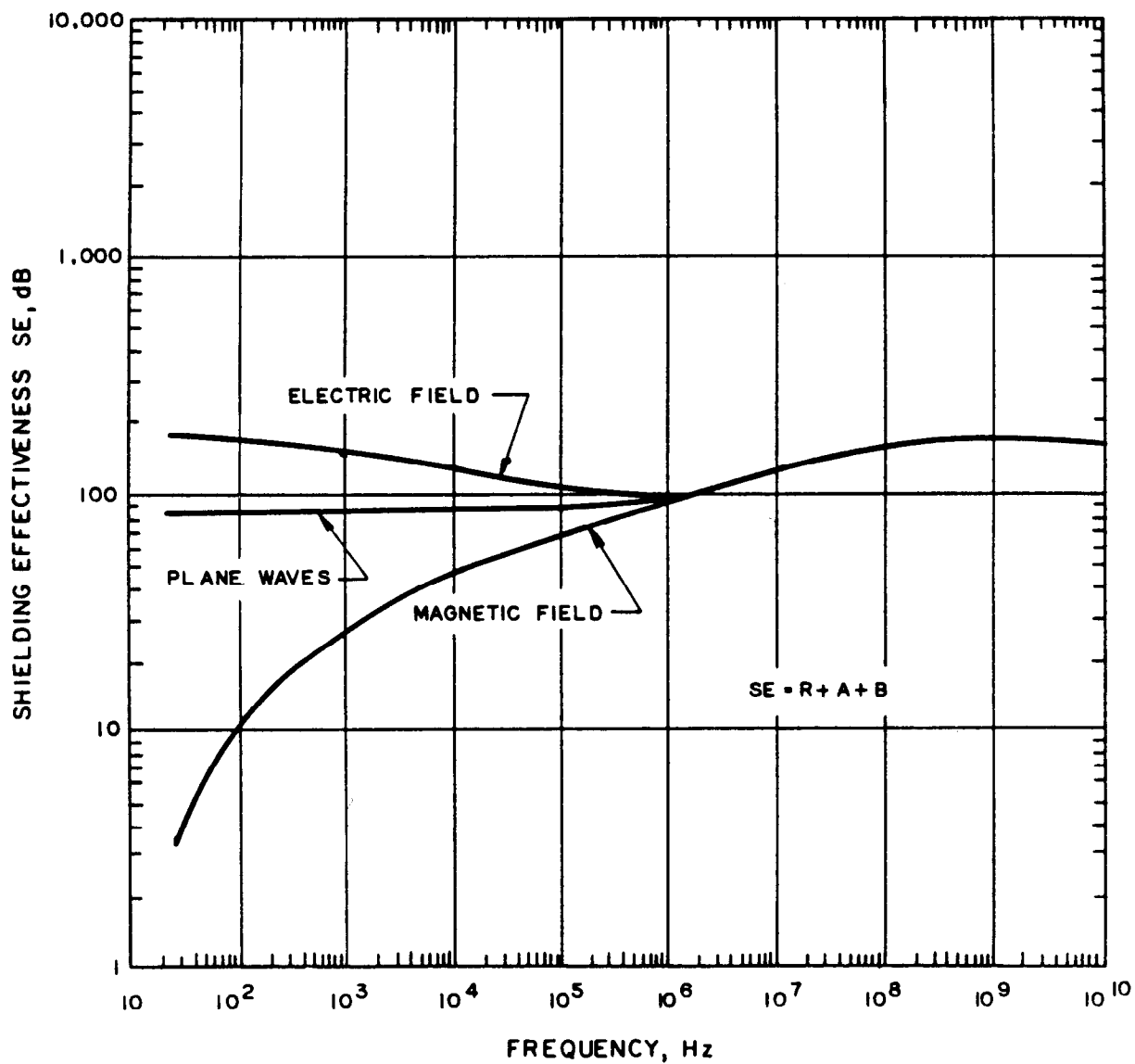


Figure 5-12. Shielding effectiveness in electric, magnetic, and plane wave fields of steel shield (1 mil thick) for signal sources 165 feet from the shield. (Source: ref 5-3)

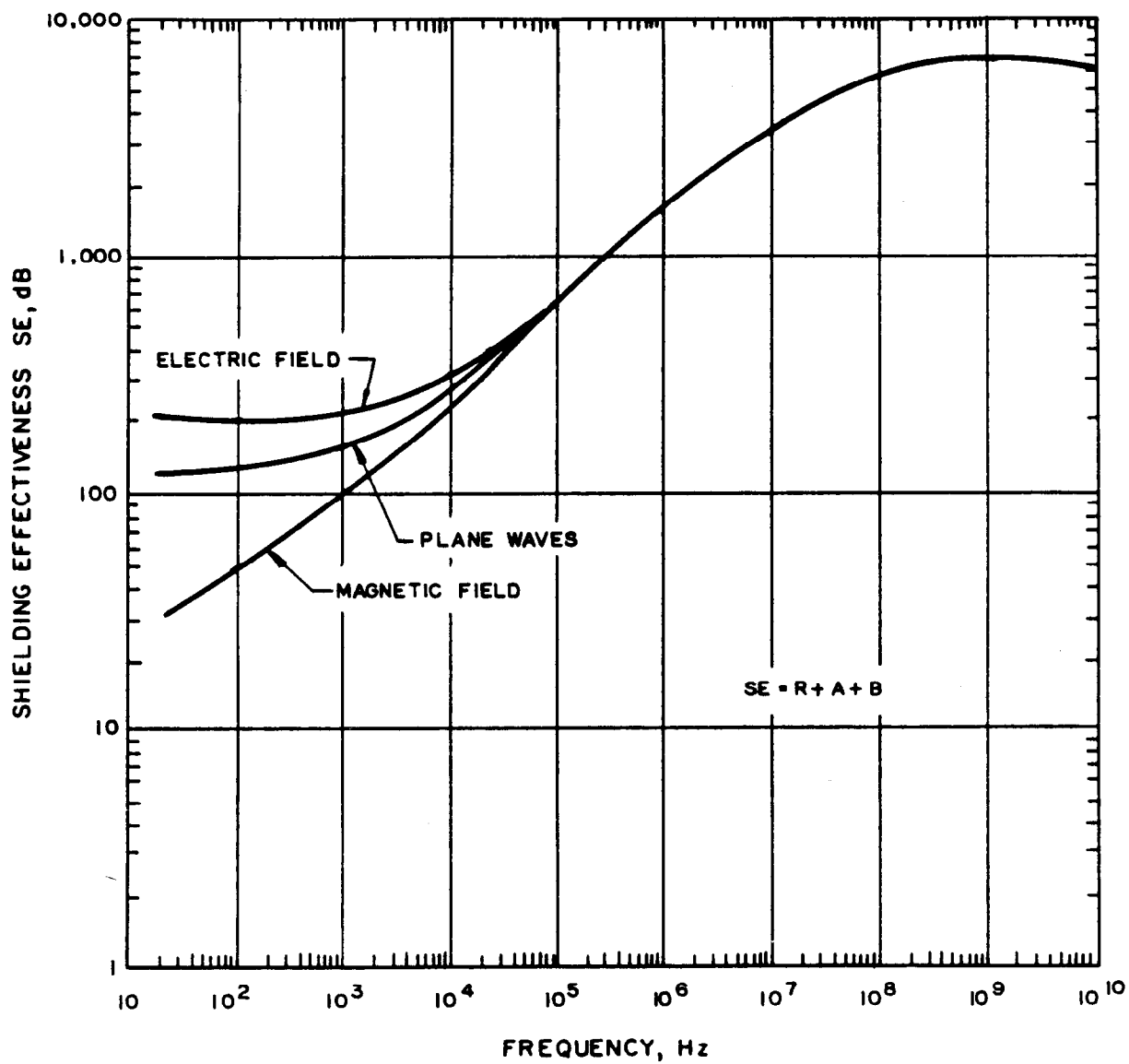
EP 1110-3-2
31 Dec 90

Figure 5-13. Shielding effectiveness in electric, magnetic, and plane wave fields of steel shield (50 mils thick) for signal sources 165 feet from the shield. (Source: ref 5-3)

EP 1110-5-2
31 Dec 90

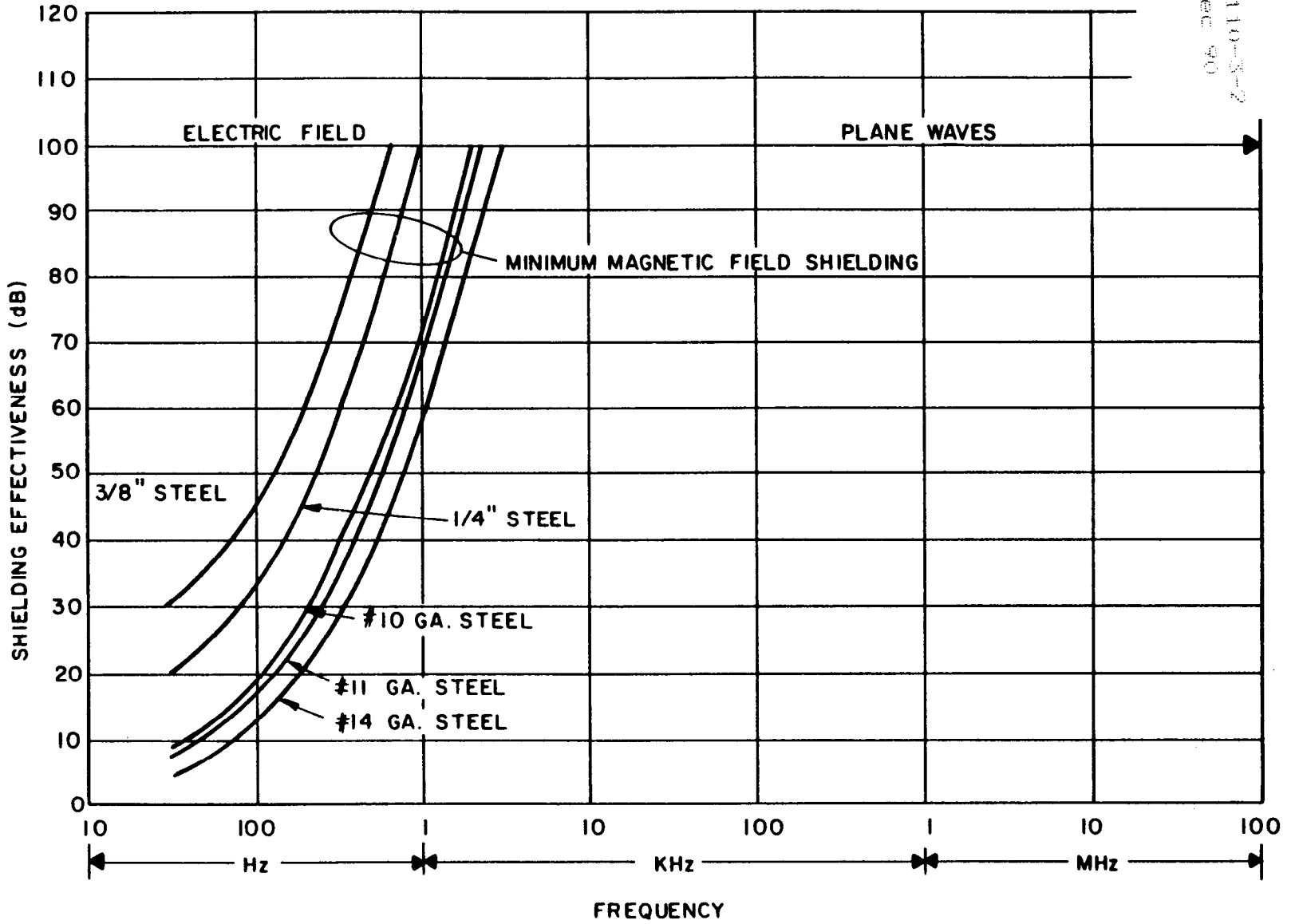


Figure 5-14. Minimum shielding effectiveness of low-carbon steel walls.
(Source: ref 5-28)

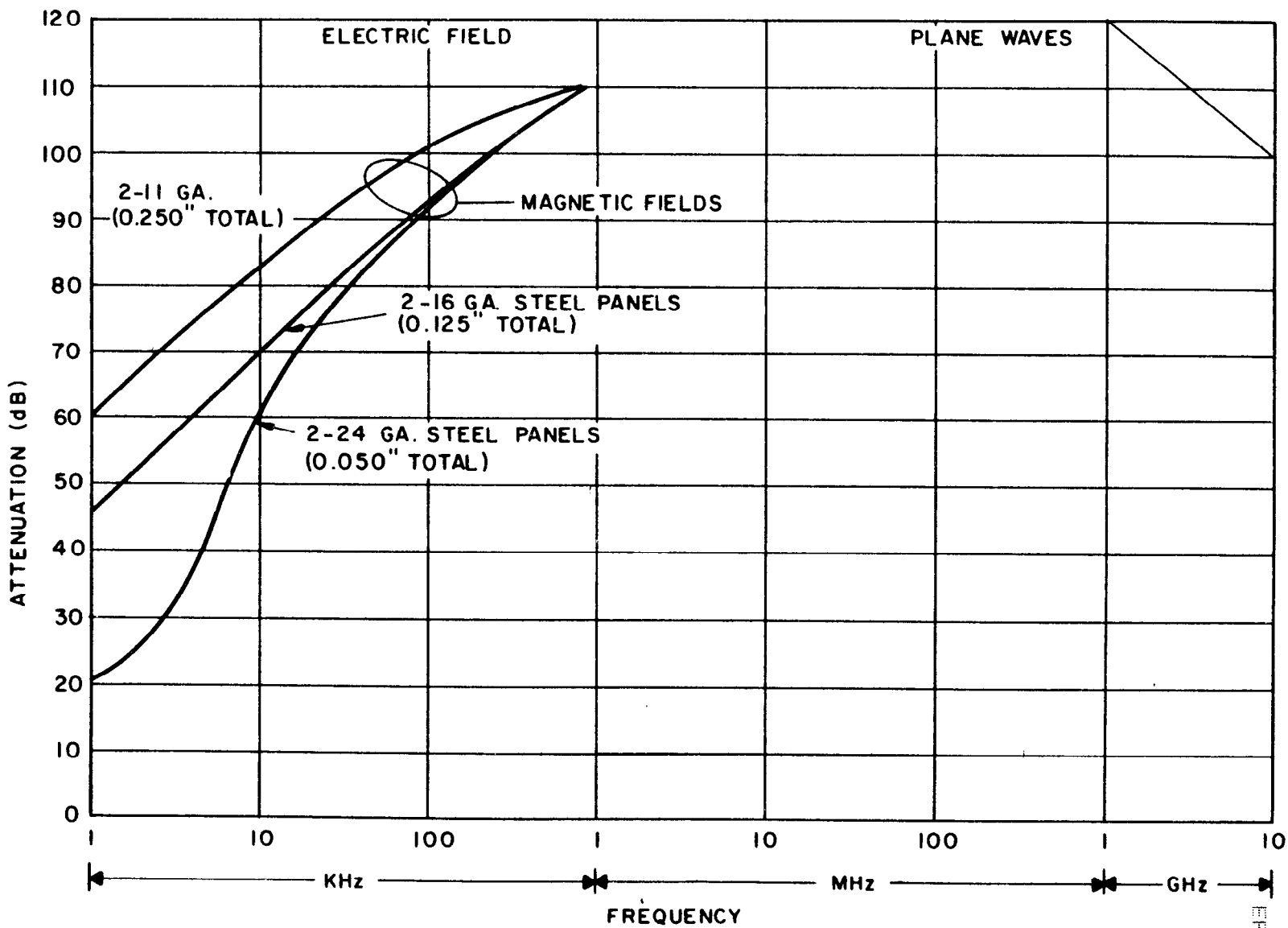


Figure 5-15. Performance characteristics of typical commercial shielded enclosures. (Source: ref 5-28)

5-111

EP 1110-3-2
31 Dec 90

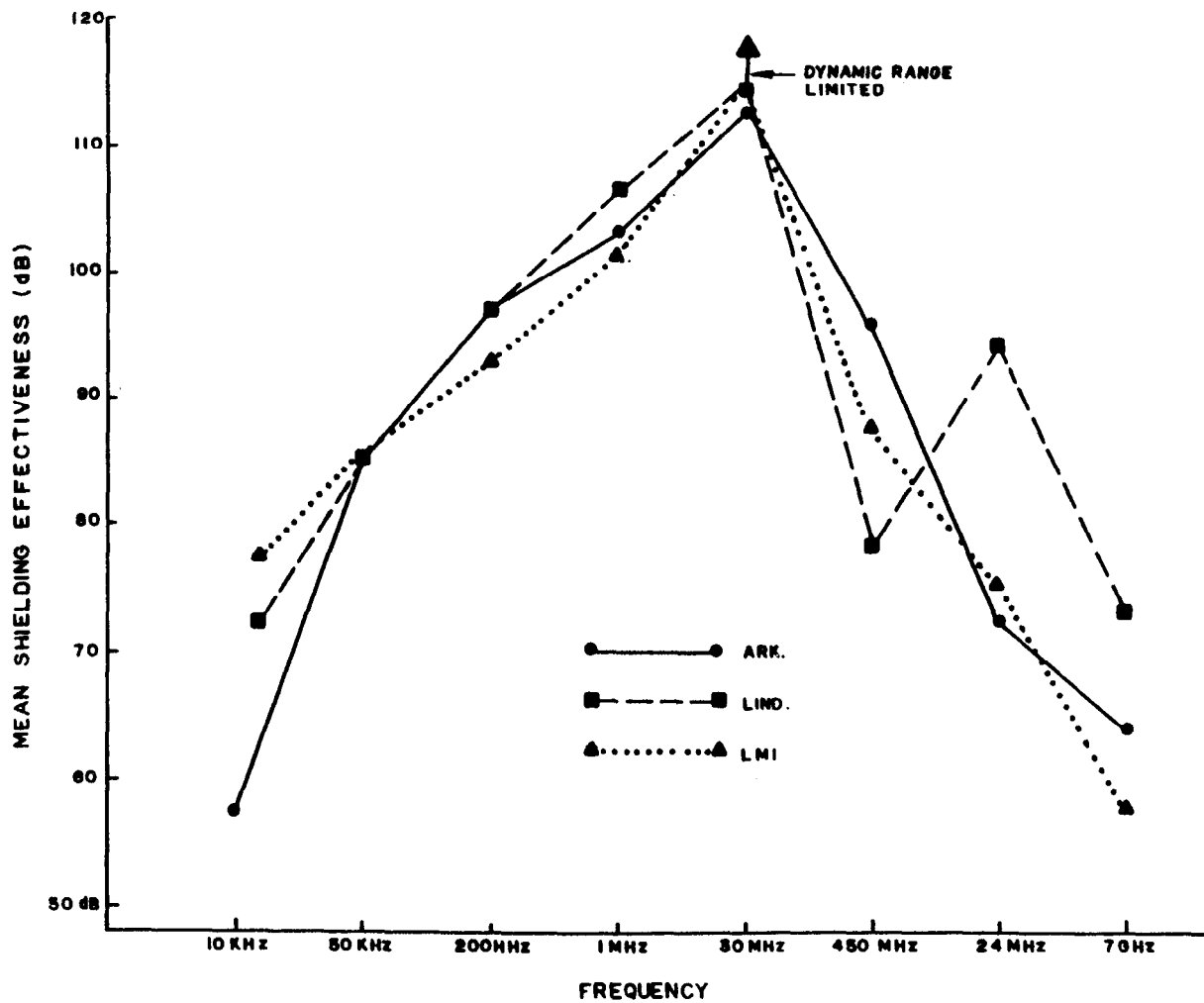
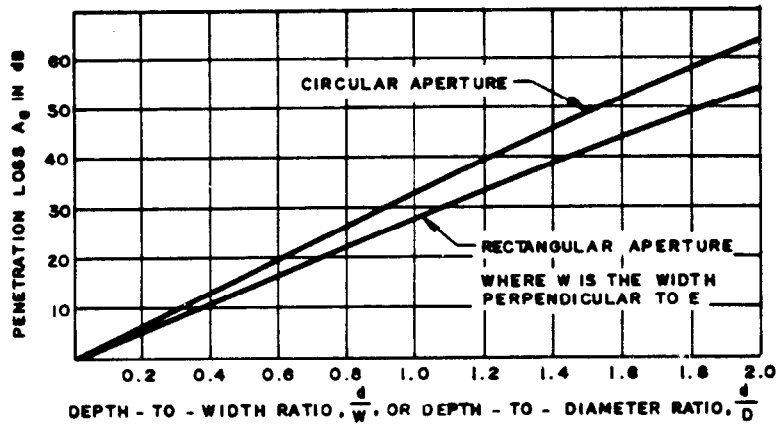


Figure 5-16. Mean shielding effectiveness for all test points for the June 1980 test. (Source: ref 5-29)

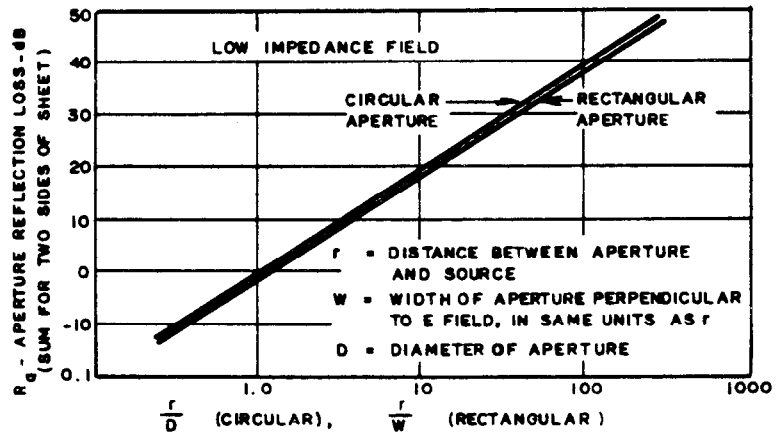
EP 1110-3-2
31 Dec 90

This page not used.

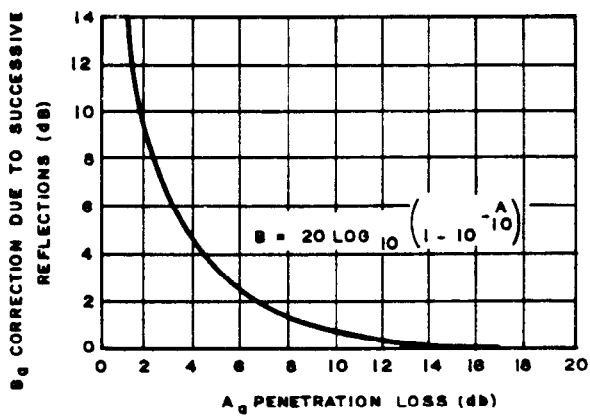
EP 1110-3-2
31 Dec 90



(a)



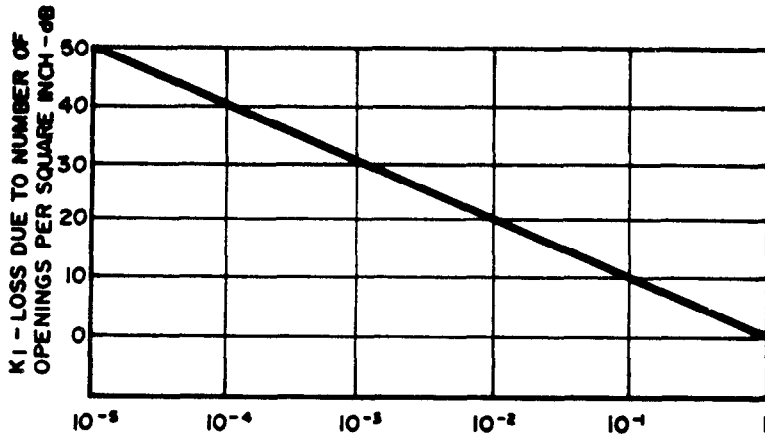
(b)



(c)

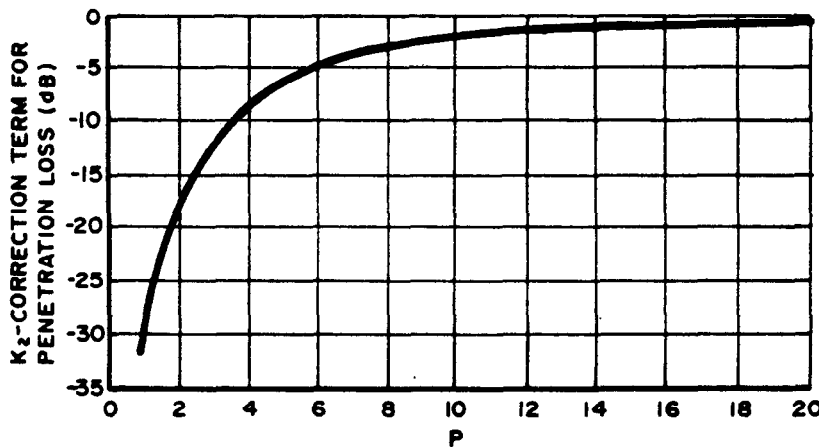
Figure 5-18. Aperture shielding. (sheet 1 of 2)

EP 1110-3-2
31 Dec 90



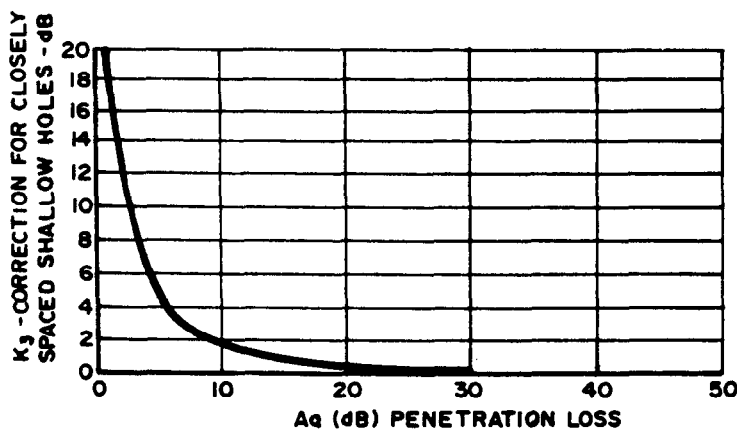
$K_1 = -10 \log an, r \gg W, D$
 $a =$ AREA OF SINGLE APERTURE
 $n =$ NUMBER OF APERTURES PER SQUARE INCH
 $r =$ DISTANCE BETWEEN SOURCE AND APERTURES
 $W =$ WIDTH OF RECTANGULAR APERTURES, PERPENDICULAR TO FIELD
 $D =$ DIAMETER OF CIRCULAR APERTURES

(d)



$P = \frac{\text{WIRE DIAMETER}}{\text{SKIN DEPTH}}$ FOR SCREENING
 $= \frac{\text{CONDUCTOR WIDTH BETWEEN HOLES}}{\text{SKIN DEPTH}}$ FOR PERFORATED SHEETS
 $K_2 = -20 \log_{10} (1 + 35P^{-2.3})$

(e)



$K_3 = 20 \log \left(\coth \frac{A_a}{8.686} \right)$

(f)

Figure 5-18. Aperture shielding. (sheet 2 of 2)

EP 1110-3-2
31 Dec 90

This page not used.

EP 1110-3-2
31 Dec 90

This page not used.

EP 1110-3-2
31 Dec 90

This page not used.

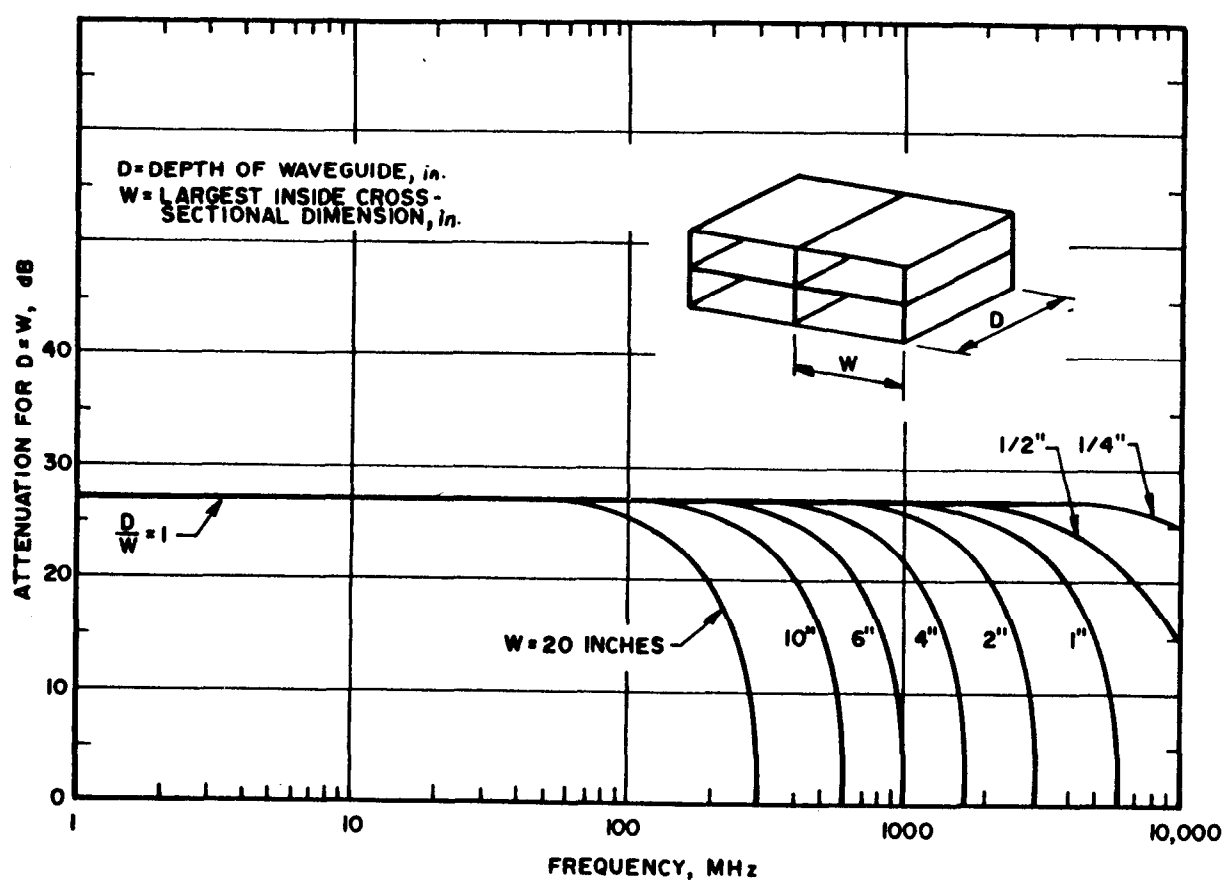


Figure 5-22. Attenuation--rectangular waveguide. (Source: ref 5-3)

EP 1110-3-2
31 Dec 90

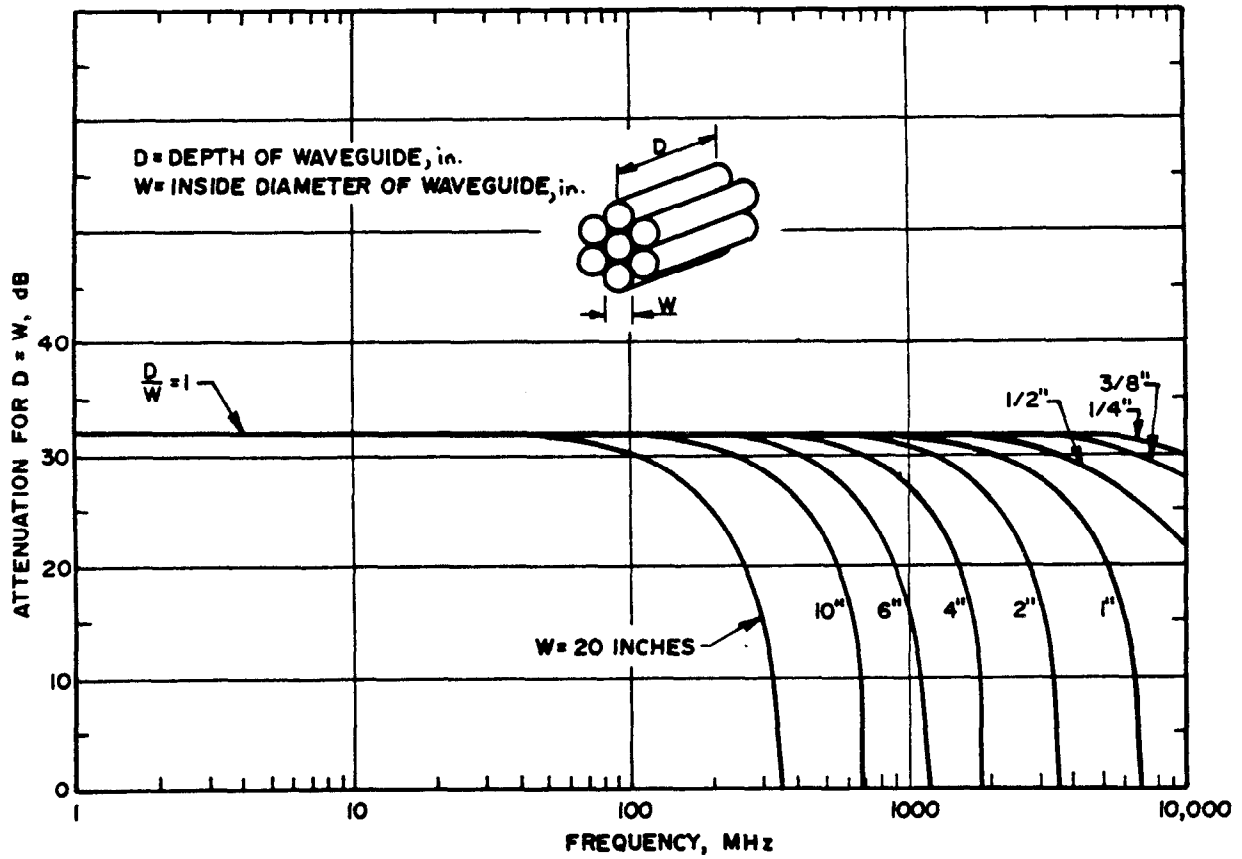


Figure 5-23. Attenuation--circular waveguide. (Source: ref 5-3)

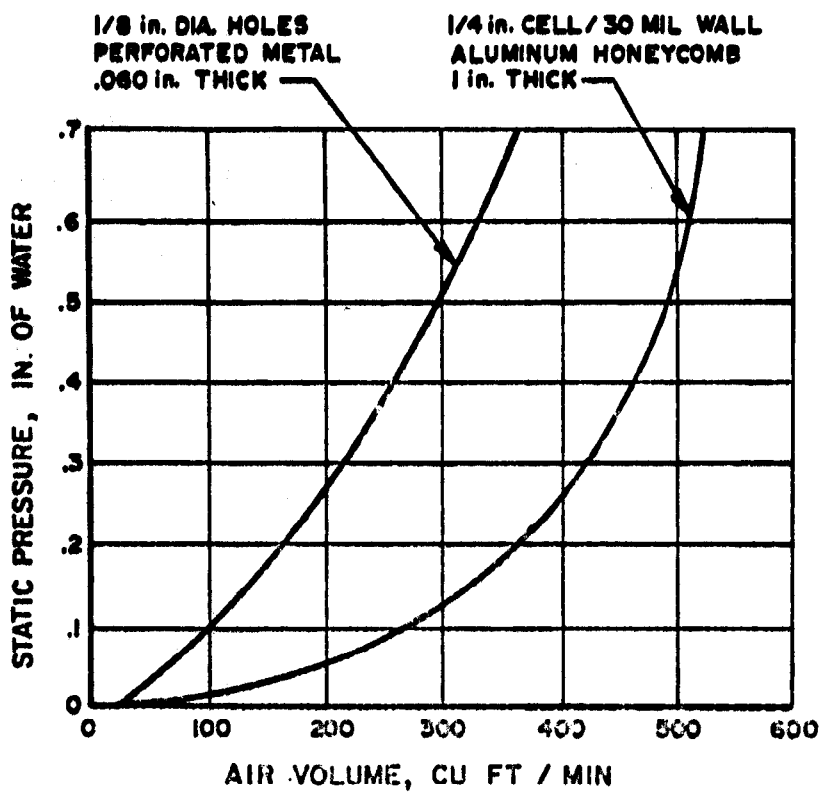


Figure 5-24. Air impedance of perforated metal and honeycomb.
(Source: ref 5-3)

EP 1110-3-2
31 Dec 90

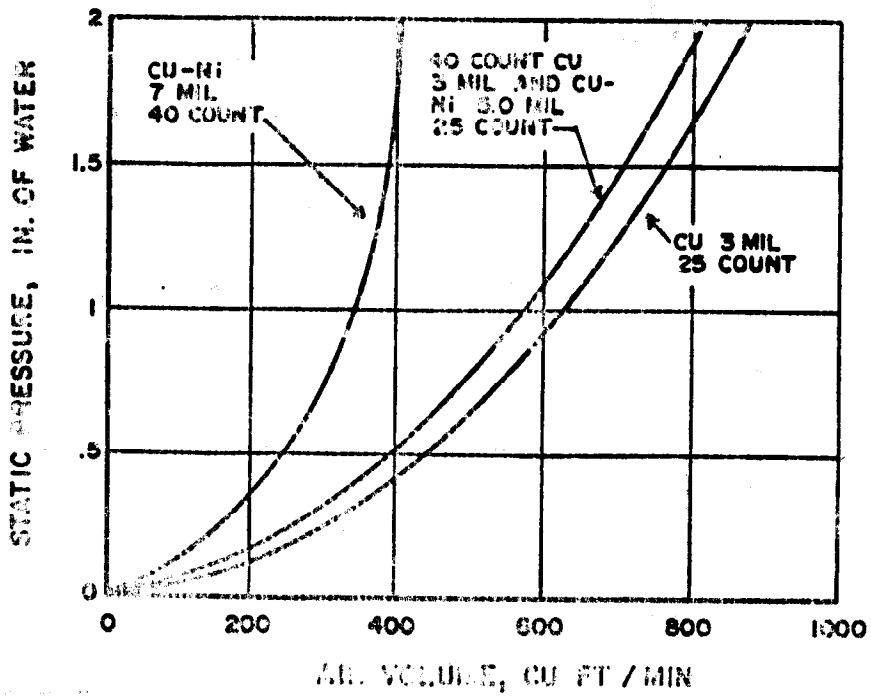


Figure 5-25. Air impedances of copper and nickel mesh. (Source: ref 5-3)

EP 1110-3-2
31 Dec 90

This page not used.

EP 1110-3-2
31 Dec 90

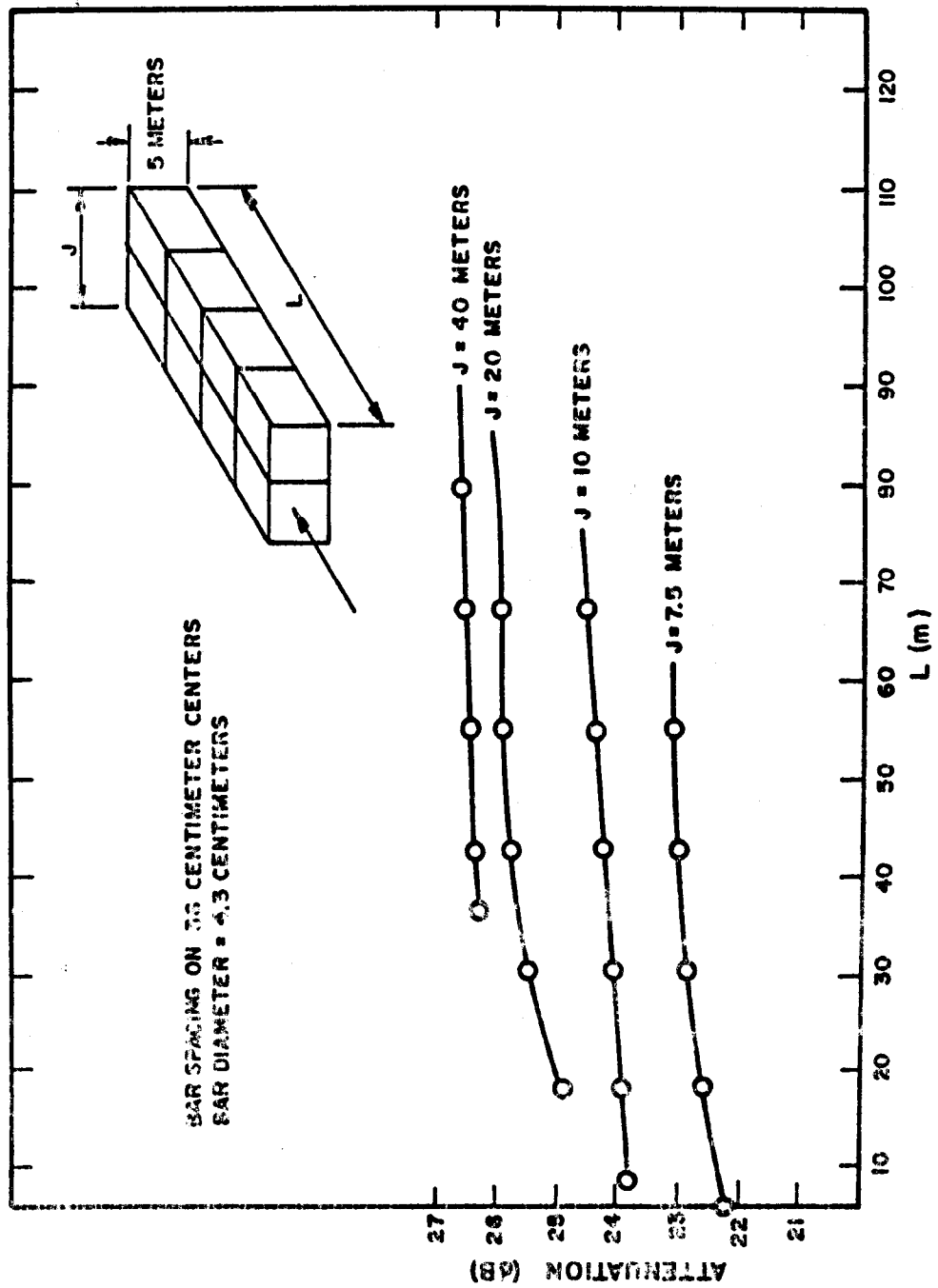
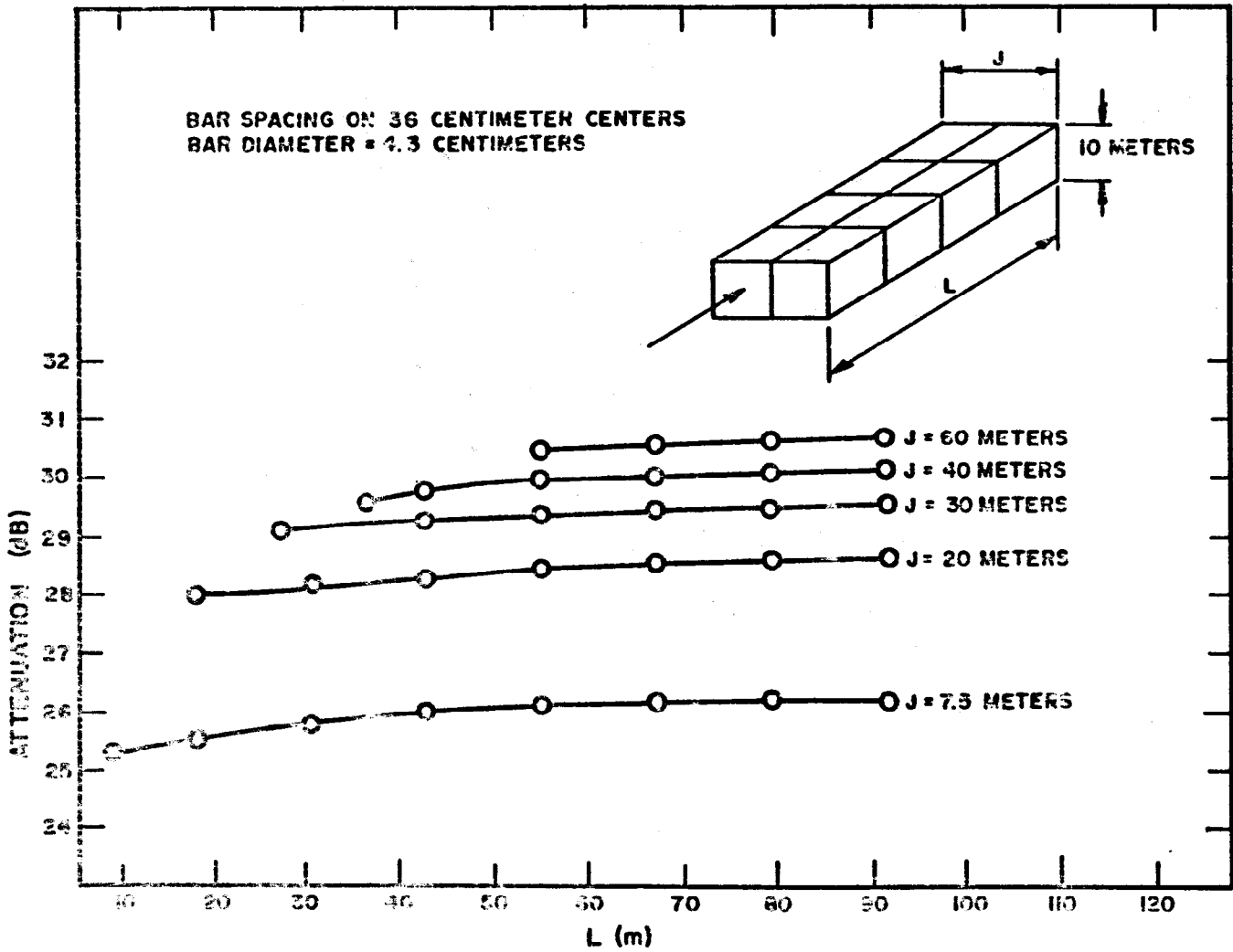


Figure 5-27. Center area attenuation of 5-meter-high, single-course reinforcing steel room. (Source: ref 5-7)

Figure 5-28. Center area attenuation of 10-meter-high, single-course reinforcing steel room. (Source: ref 5-7)



EP 1110-3-2
31 Dec 90

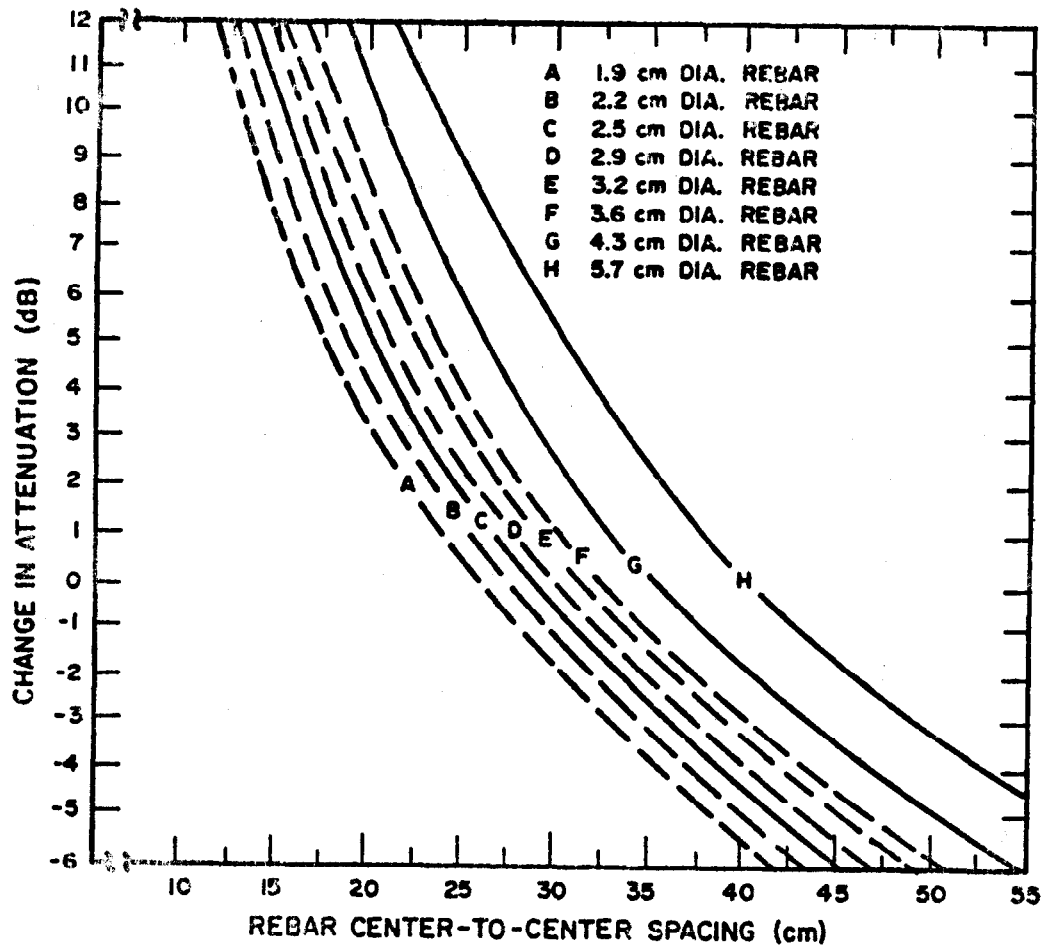


Figure 5-29. Correction curves for various rebar diameters and spacings using single-course rebar construction. (Source: ref 5-7)

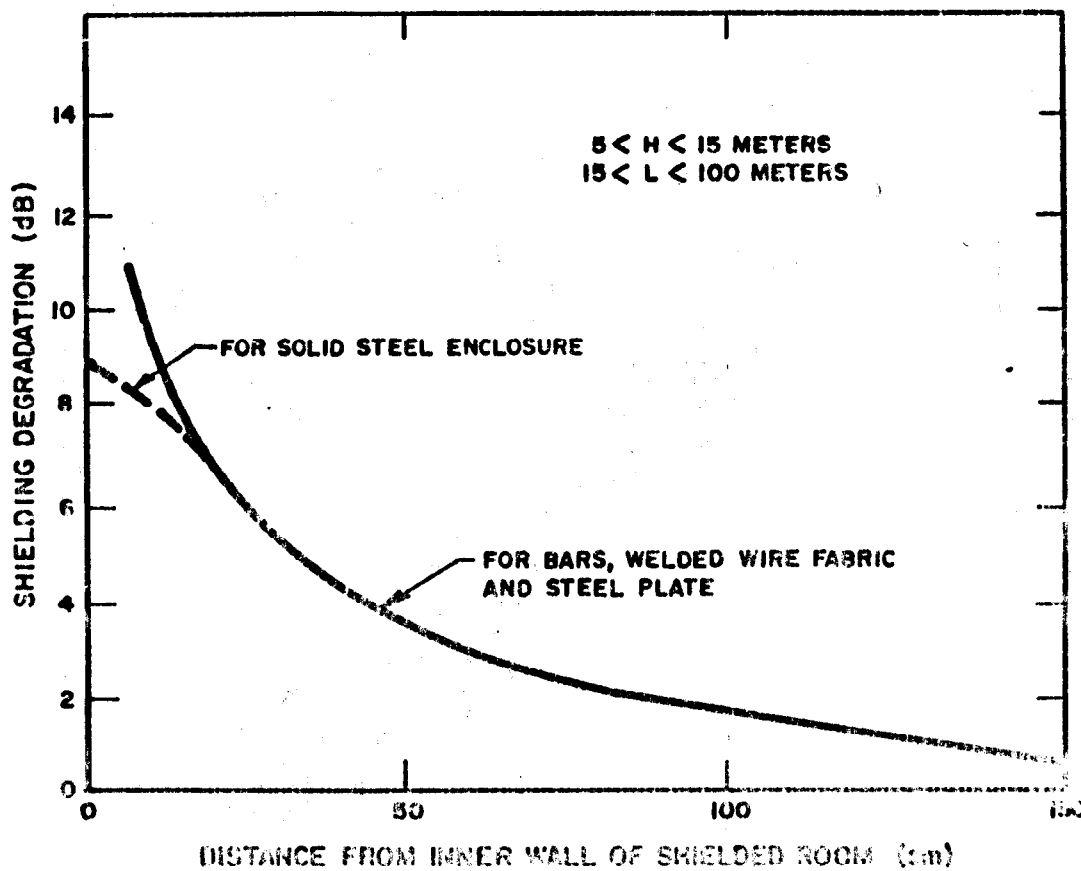
EP 1110-3-2
31 Dec 90

Figure 5-30. Shielding degradation versus distance from wall.
(Source: ref 5-7)

EP 1110-3-2
31 Dec 90

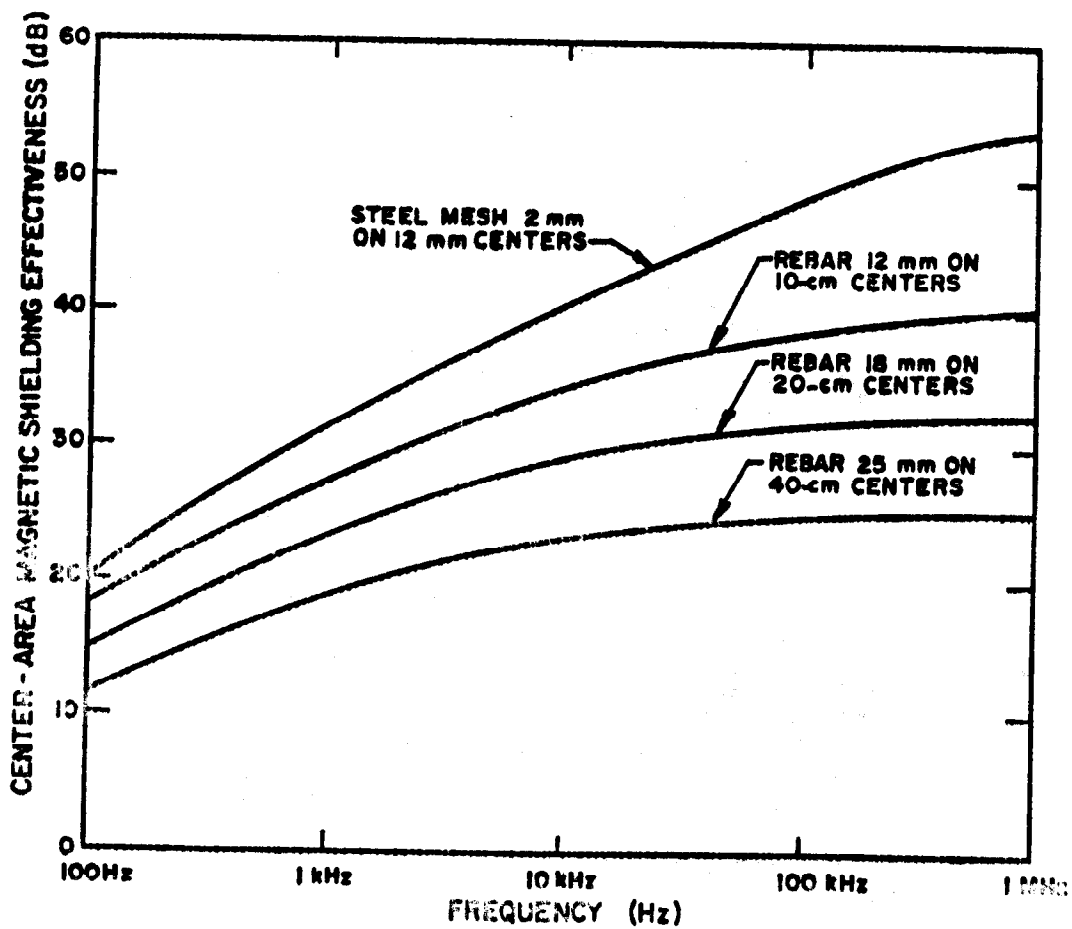


Figure 5-31. Shielding effectiveness of reinforcement steel.
(Source: ref 5-7)

EP 1110-3-2
31 Dec 90

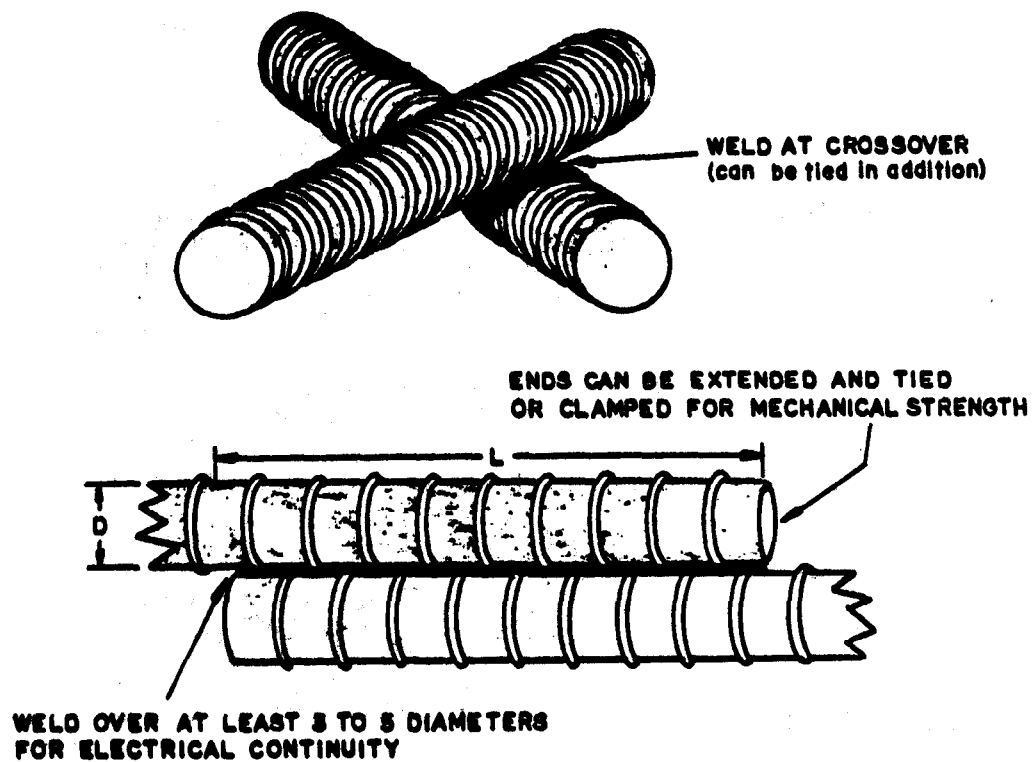


Figure 5-32. Reinforcement steel welding practice. (Source: ref 5-7)

EP 1110-3-2
31 Dec 90

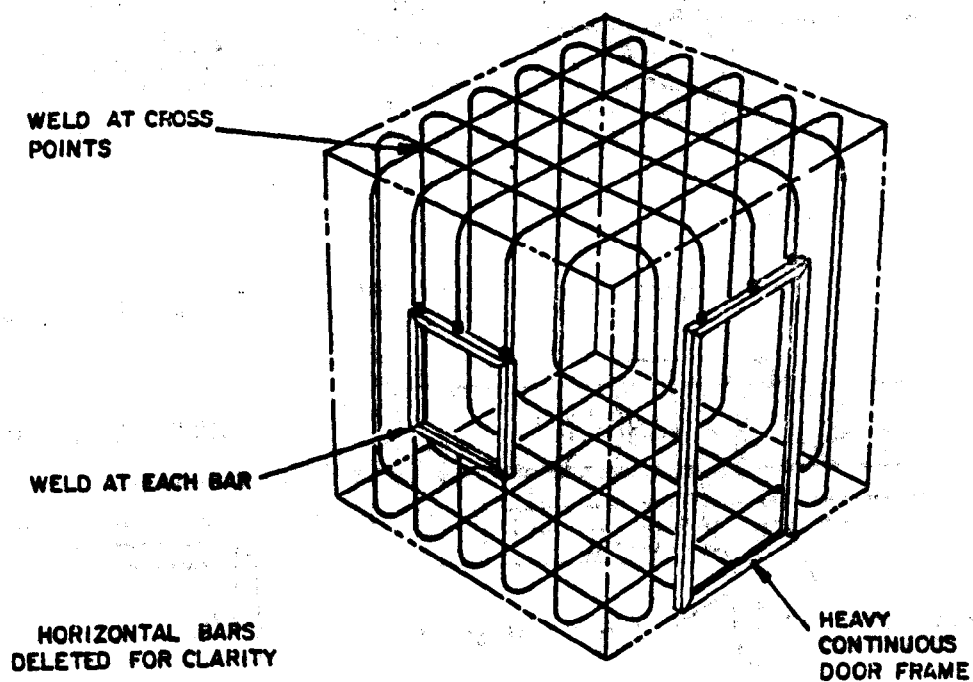


Figure 5-33. Schematic presentation--reinforcement steel shield.
(Source: ref 5-7)

EP 1110-3-2
31 Dec 90

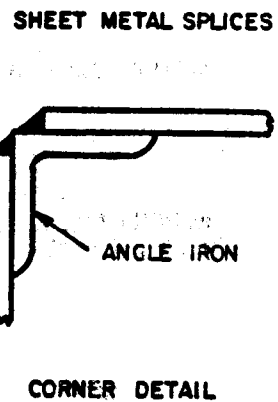
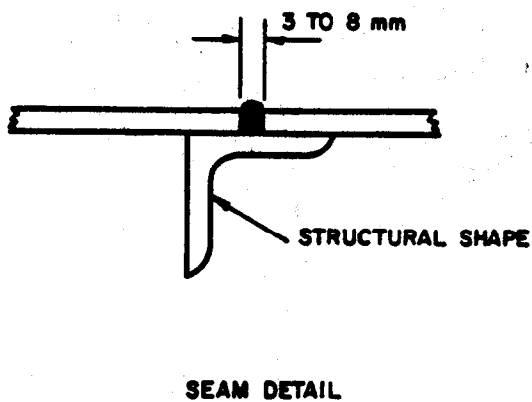
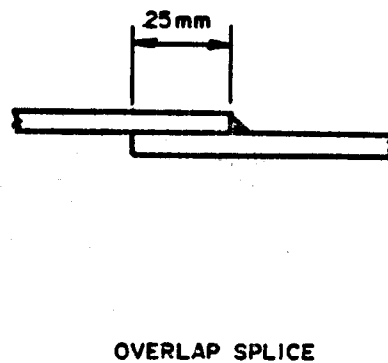
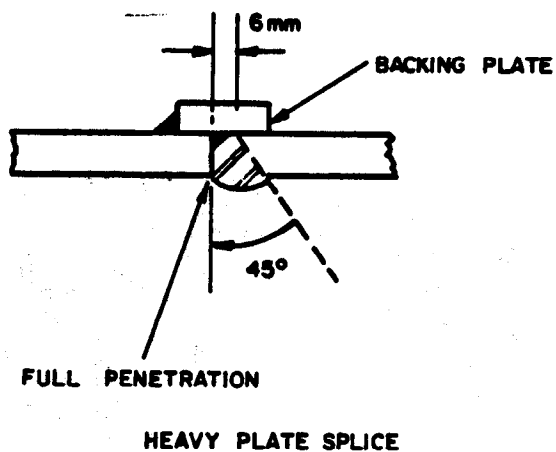


Figure 5-34. Weld joints for sheet steel shields. (Source: ref 5-7)

EP 1110-3-2
31 Dec 90

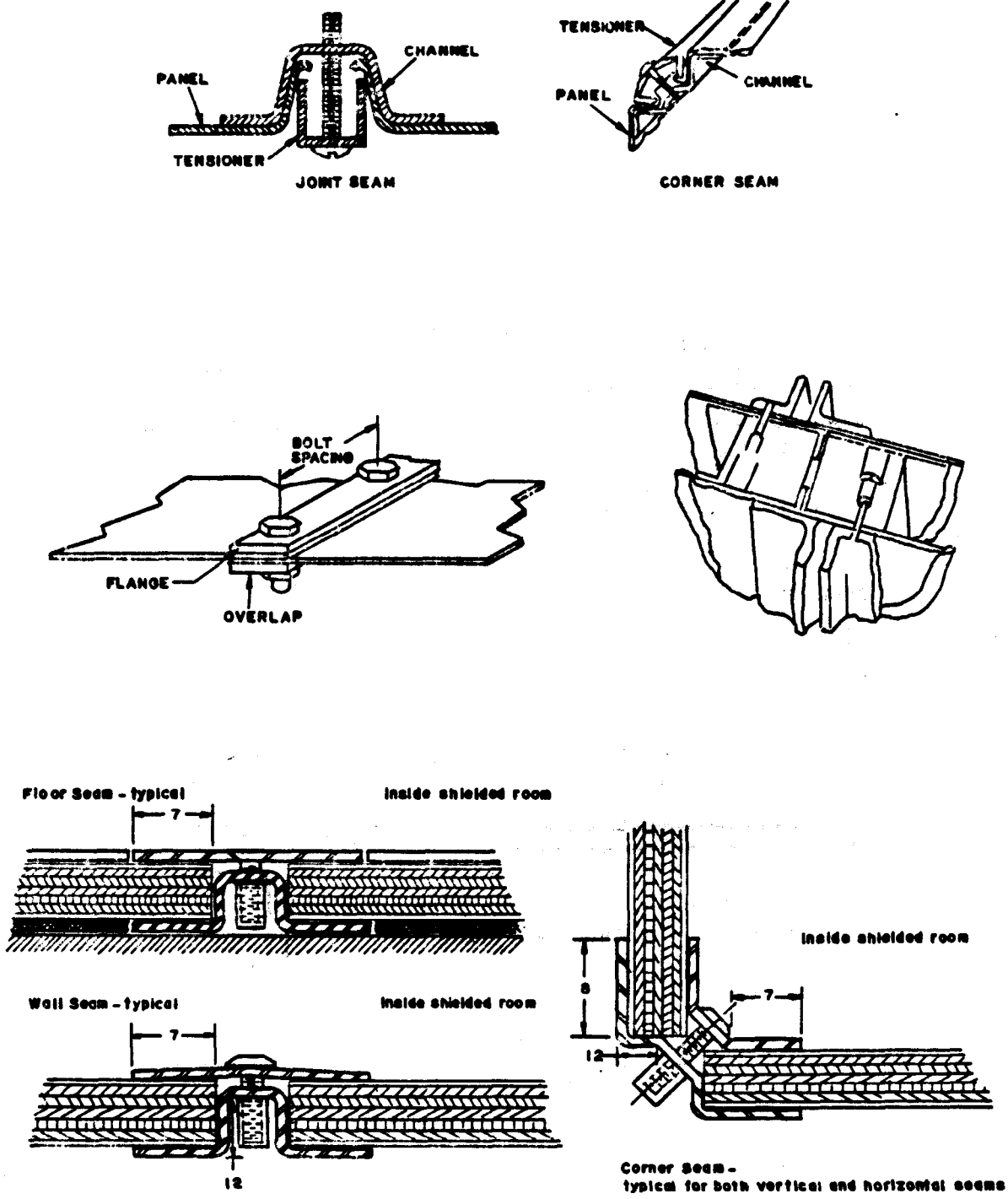


Figure 5-35. Bolted joints for metallic shields. (Source: ref 5-7)

EP 1110-3-2
31 Dec 90

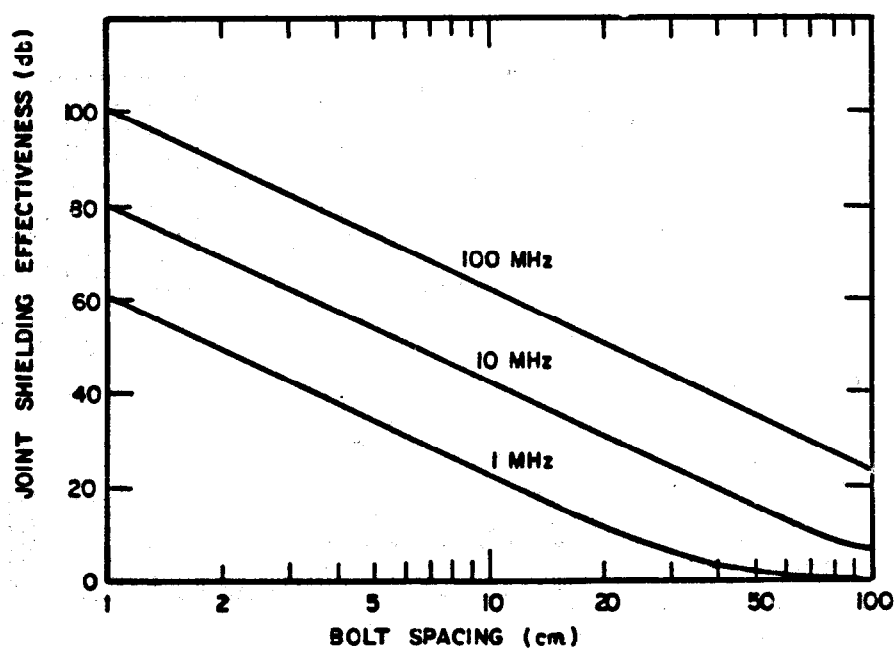


Figure 5-36. Shielding effectiveness for bolted joints. (Source: ref 5-7)

EP 1110-3-2
31 Dec 90

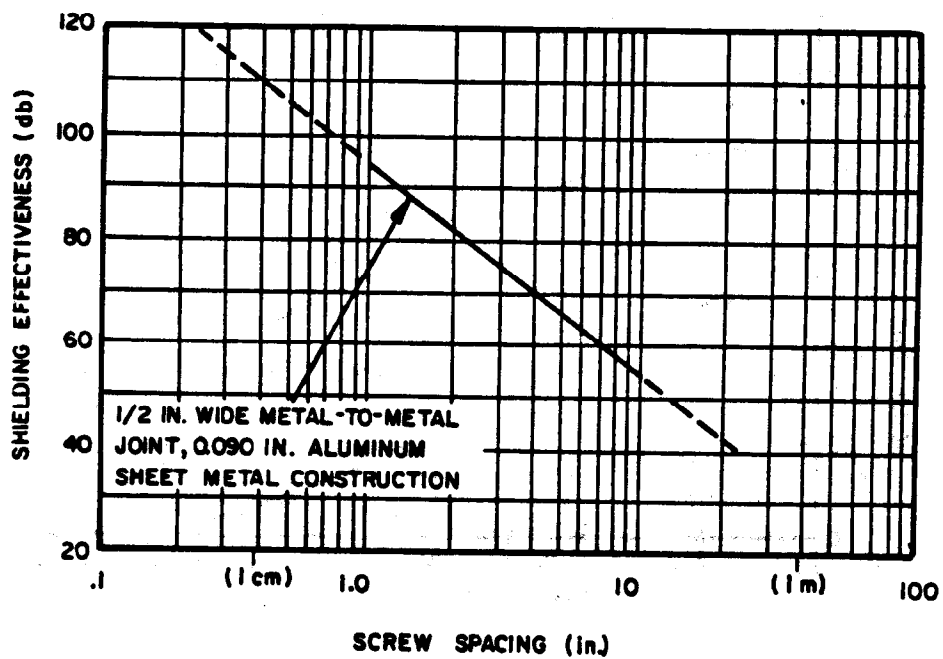


Figure 5-37. Influence of screw spacing on shielding effectiveness.
(Source: ref 5-6)

EP 1110-3-2
31 Dec 90



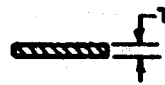

							
<u>Deflection</u>	<u>W</u> <u>Diam</u>	<u>Deflection</u>	<u>H</u>	<u>Deflection</u>	<u>T</u>	<u>Deflection</u>	<u>A</u>
.007 - .018	.070	.006 - .012	.068	.001 - .002	.020	.025 - .080	.200
.010 - .026	.103	.006 - .016	.089	.001 - .003	.032	.030 - .125	.250
.013 - .031	.125	.012 - .024	.131	.003 - .006	.062	.075 - .250	.360
.014 - .035	.139	.014 - .029	.136	.003 - .009	.093		
		.016 - .032	.175				

Figure 5-38. Gasket deflection limits (in inches). (Source: ref 5-30)

EP 1110-3-2
31 Dec 90

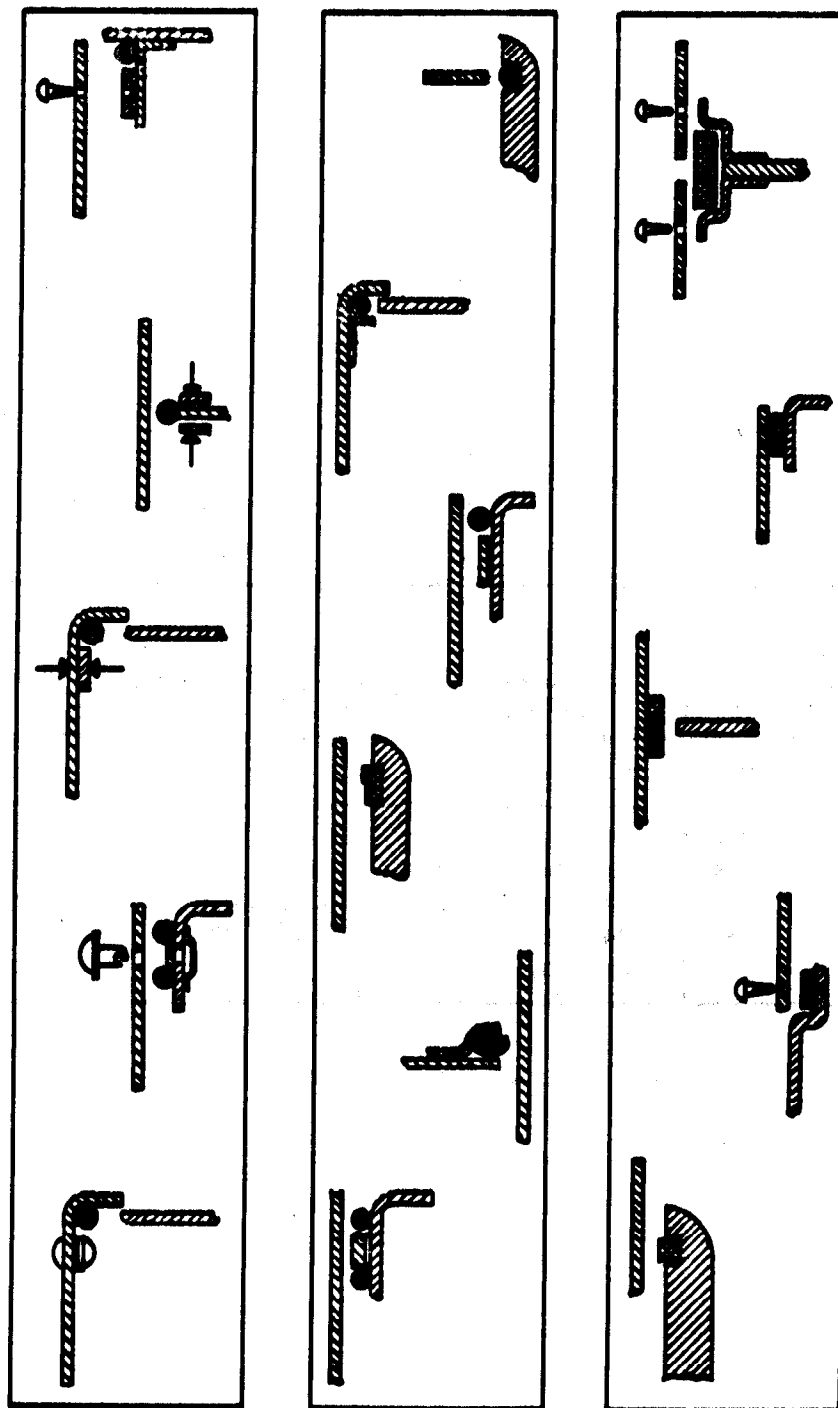
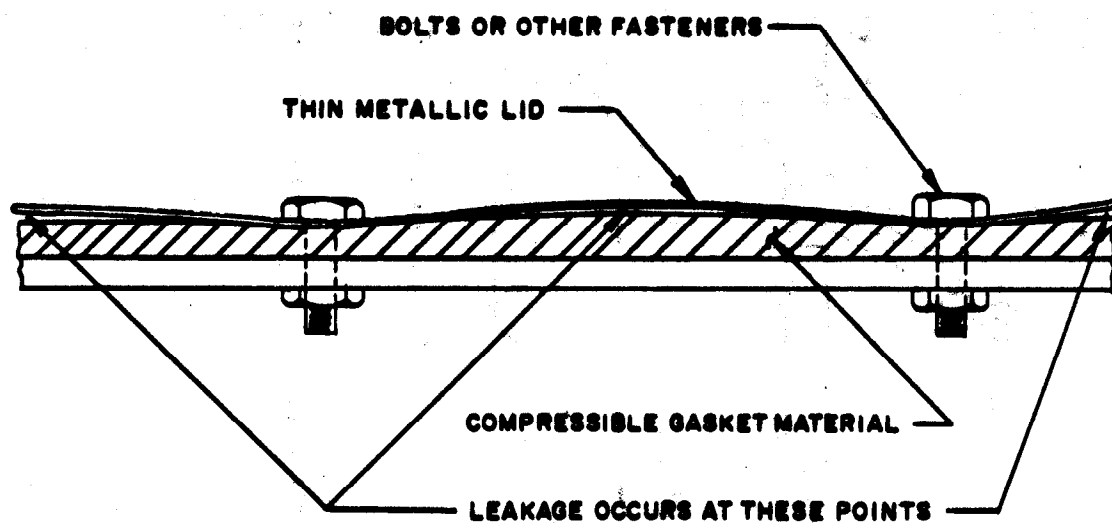


Figure 5-39. Typical mounting techniques for RF gaskets. (Source: ref 5-6)

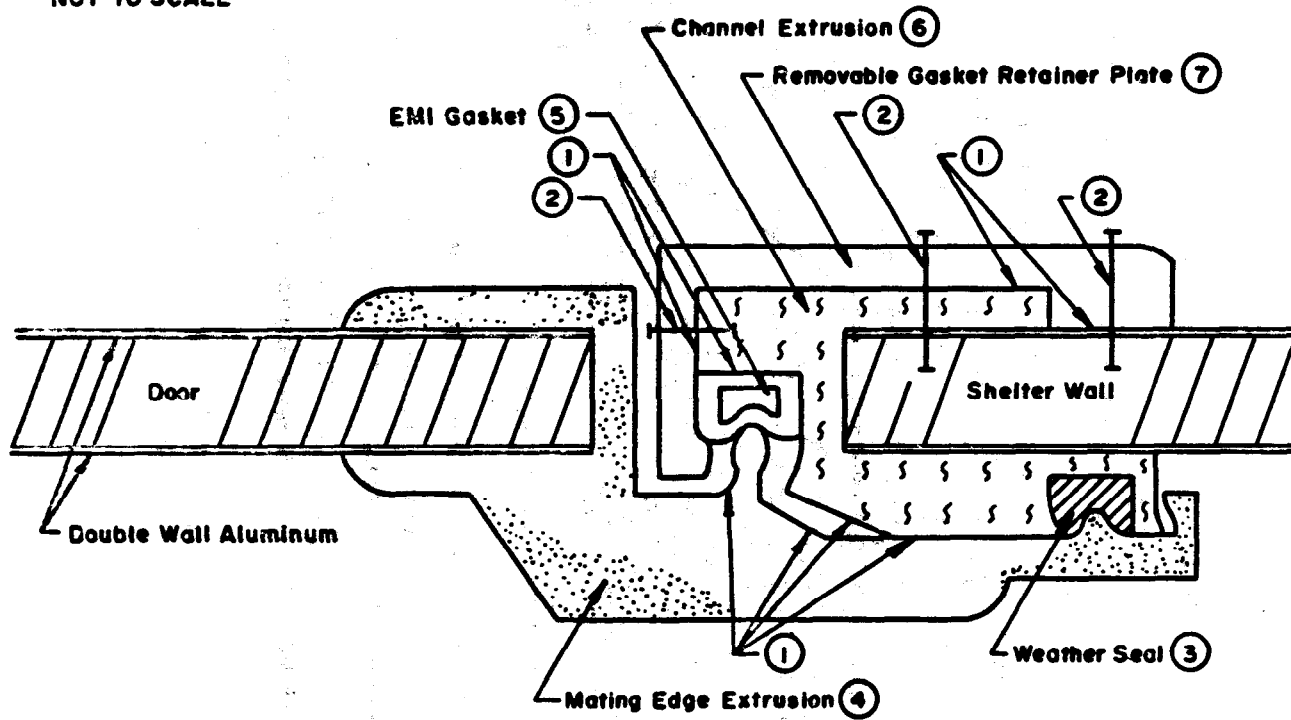
EP 1110-3-2
31 Dec 90



NOTE: VIEW PURPOSELY EXAGGERATED TO DEMONSTRATE IMPERFECT SEAL CONDITIONS.

Figure 5-40. Improper gasket application. (Source: ref 5-3)

NOT TO SCALE



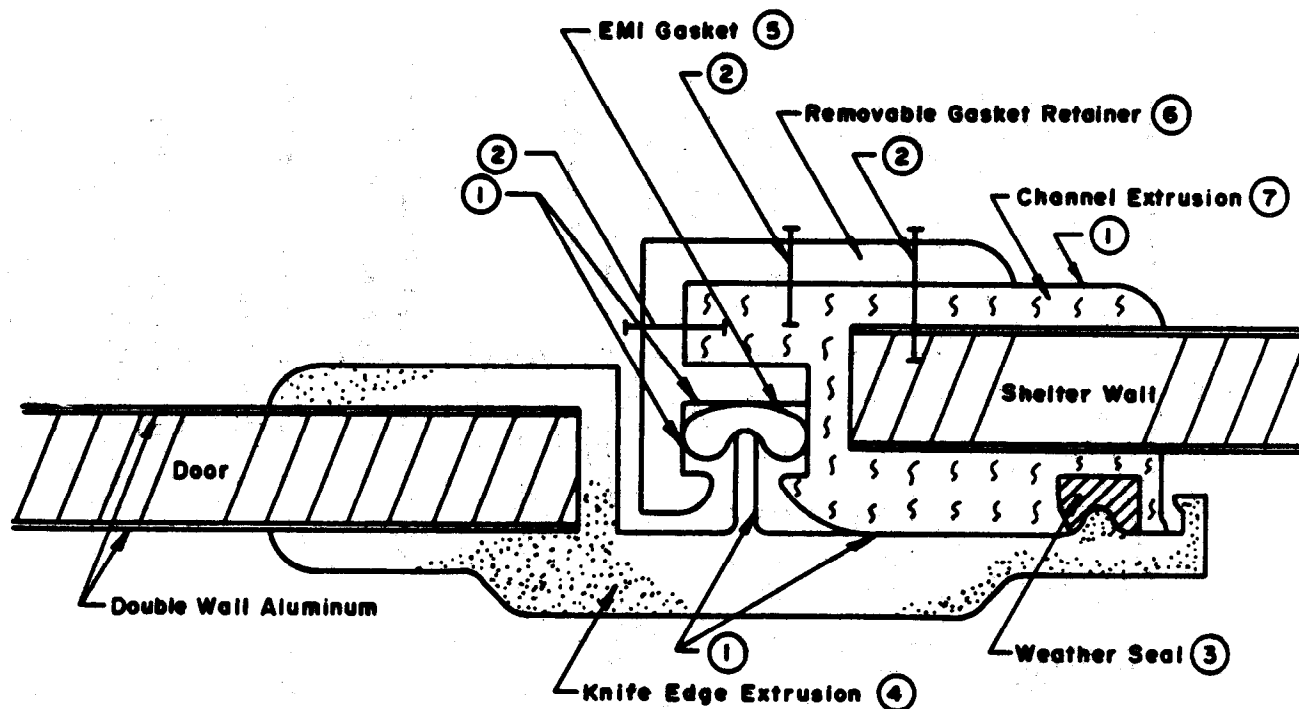
- ① = Surfaces with Tin Coating or Plating
- ② = Bolts or Screws to Affix Retainer Plate
- ③ = Silicone, Hollow Extrusion Elastomer
- ④ = Aluminum Extrusion Welded to Door
- ⑤ = Knitted Wire Mesh Gasket with Hollow "D" Elastomer
- ⑥ = Aluminum Extrusion Welded to Shelter Wall
- ⑦ = Aluminum Extrusion Plate Bolted to Channel Extrusion

Figure 5-41. EMI shielded door seam (mesh gasket). (Source: ref 5-8)

5-138

EP 1110-3-2
31 Dec 90

NOT TO SCALE

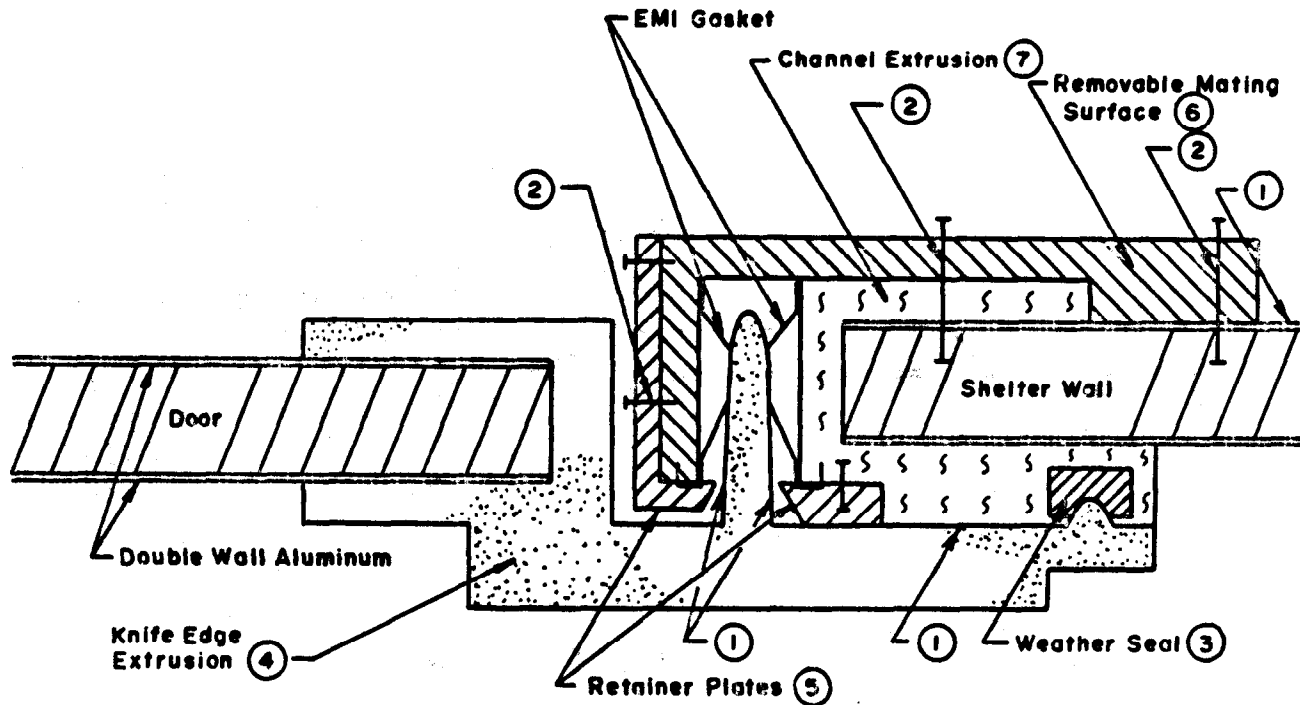


- | | |
|---|---|
| ① = Surfaces with Tin Coating or Plating | ⑤ = Tin-Plated Spiral "OVAL" Gasket |
| ② = Bolts or Screws to Affix Retainer Plate | ⑥ = Tin-Plated Aluminum Extrusion Gasket Retainer |
| ③ = Silicone, Hollow Extruded Elastomer | ⑦ = Aluminum Extrusion Welded to Shelter |
| ④ = Aluminum Extrusion Welded to Door | |

Figure 5-42. EMI shielded door seam ("oval" spiral gasket).
(Source: ref 5-8)

EP 1110-3-2
31 Dec 90

NOT TO SCALE



- | | |
|--|--|
| ① = Surfaces with Tin Coating or Plating | ⑤ = Tin-Plated Aluminum Retainer Plates |
| ② = Bolts or Screws to Affix Retainer Plates | ⑥ = Aluminum Extrusion Bolted to Shelter (Removable) |
| ③ = Silicone, Hollow Extrusion Elastomer | ⑦ = Aluminum Extrusion Welded to Shelter |
| ④ = Aluminum Extrusion Welded to Door | |

Figure 5-43. EMI shielded door seam (fingerstock). (Source: ref 5-8)

EP 1110-3-2
31 Dec 90

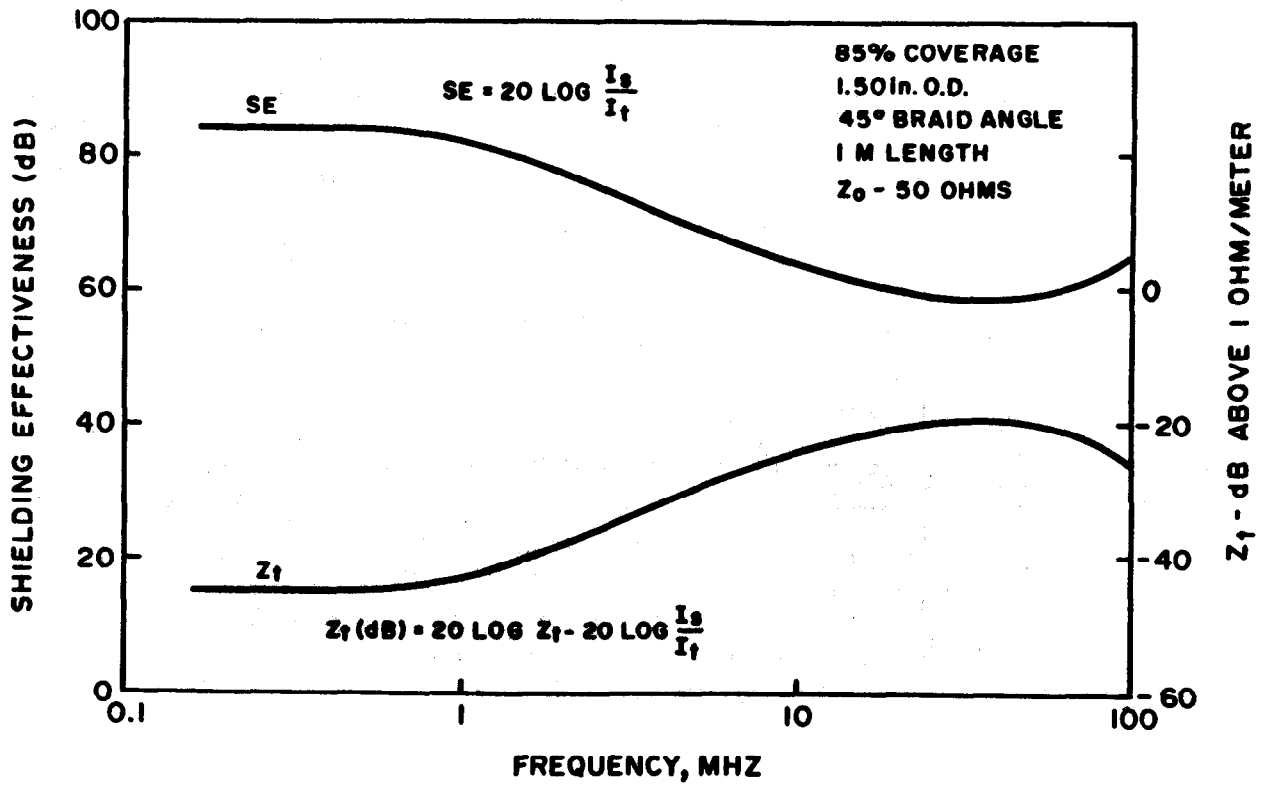


Figure 5-44. Shielding effectiveness and transfer impedance.
(Source: ref 5-11)

EP 1110-3-2
31 Dec 90

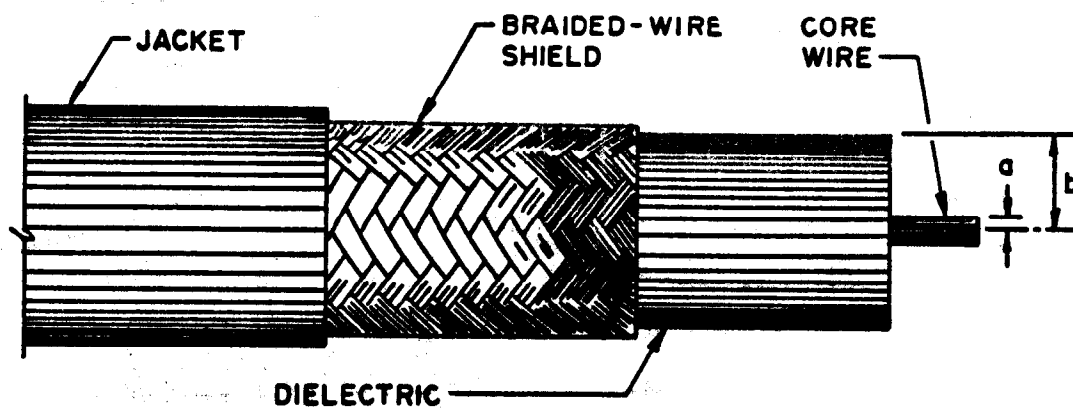


Figure 5-45. A braided-shield coaxial cable. (Source: ref 5-16)

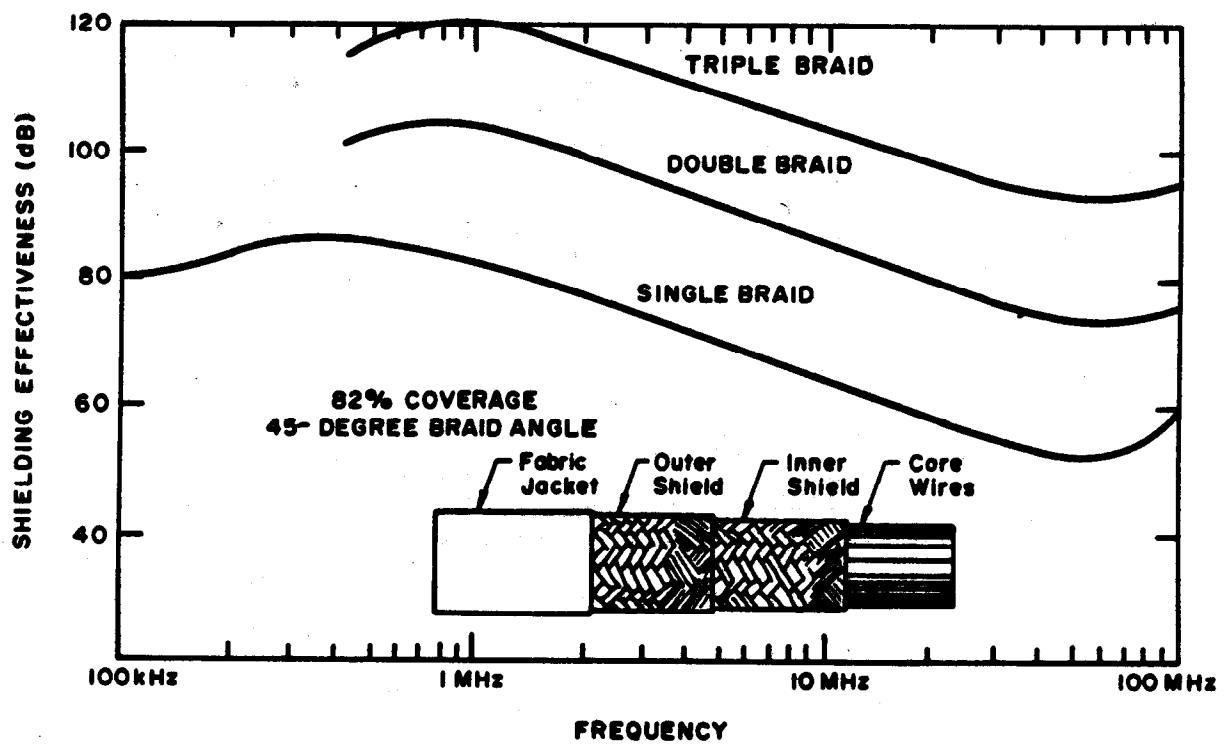
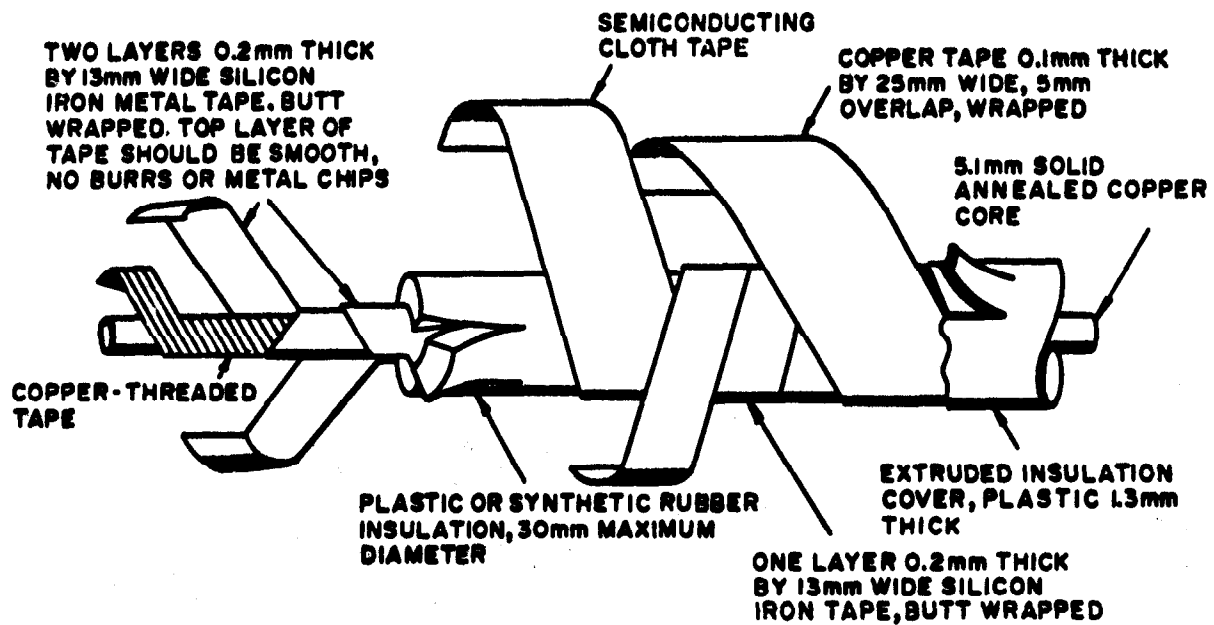
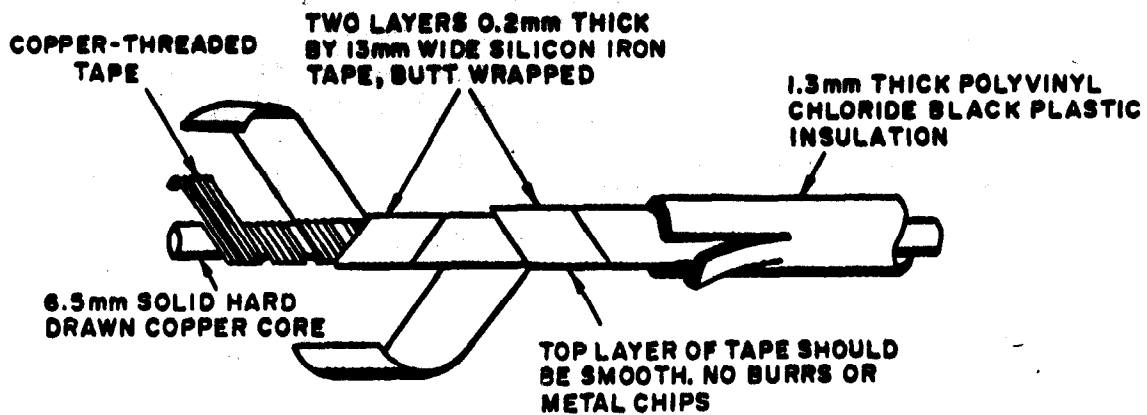
EP 1110-3-2
31 Dec 90

Figure 5-46. Cable shielding effectiveness with number of braid layers.
(Source: ref 5-7)

EP 1110-3-2
31 Dec 90



UNDERGROUND CABLE



OVERHEAD CONDUCTOR

Figure 5-47. Lossy conductor construction. (Source: ref 5-7)

EP 1110-3-2
31 Dec 90

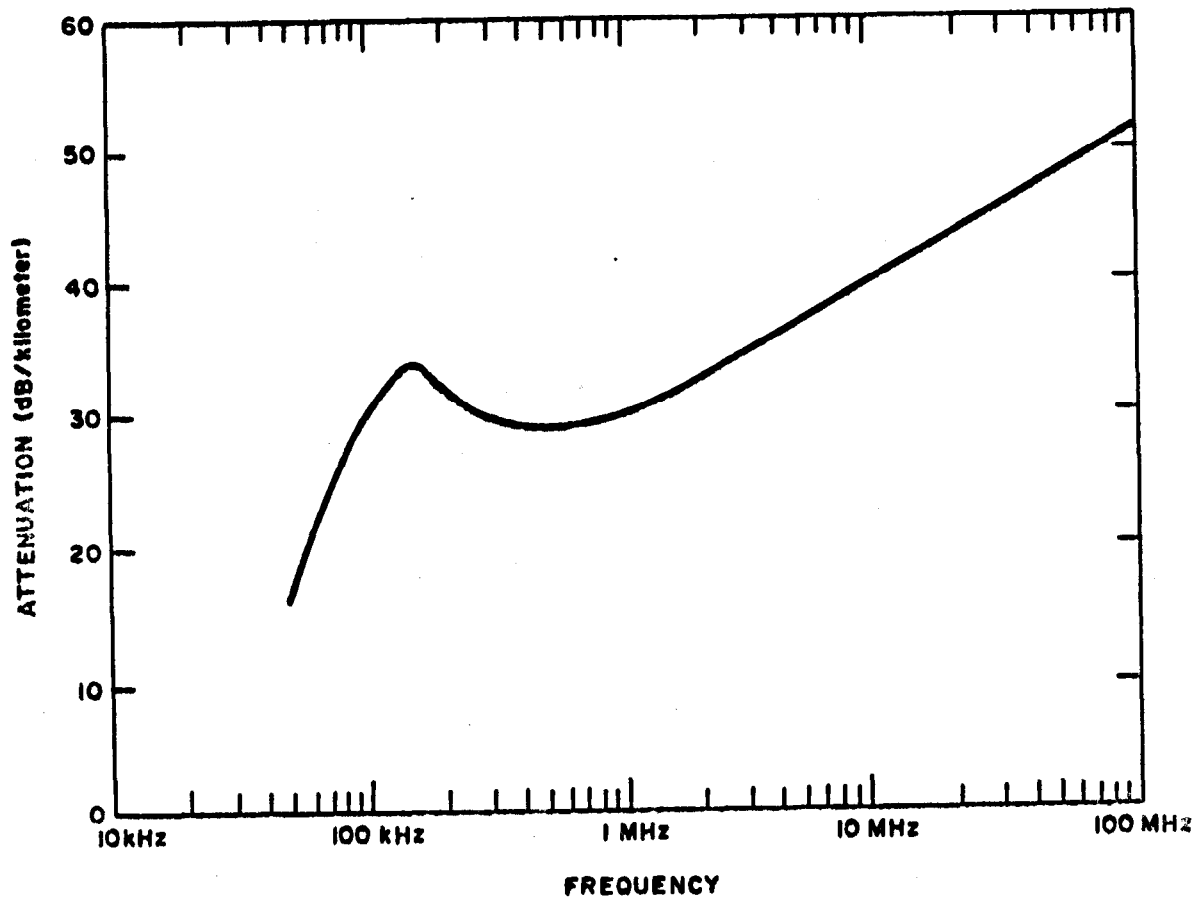


Figure 5-48. Attenuation of HEMP interference propagating on lossy-wrapped conductors. (Source: ref 5-7)

EP 1110-3-2
31 Dec 90

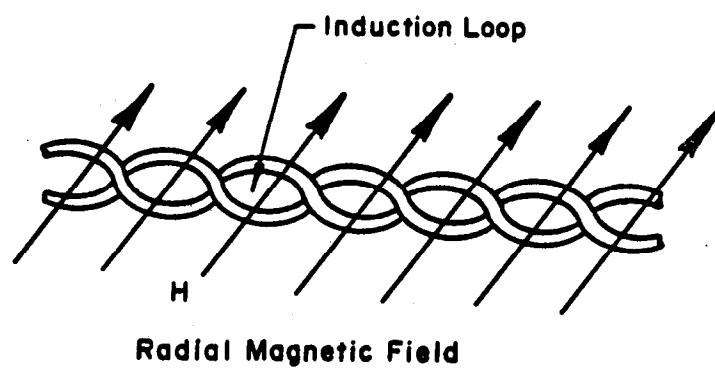
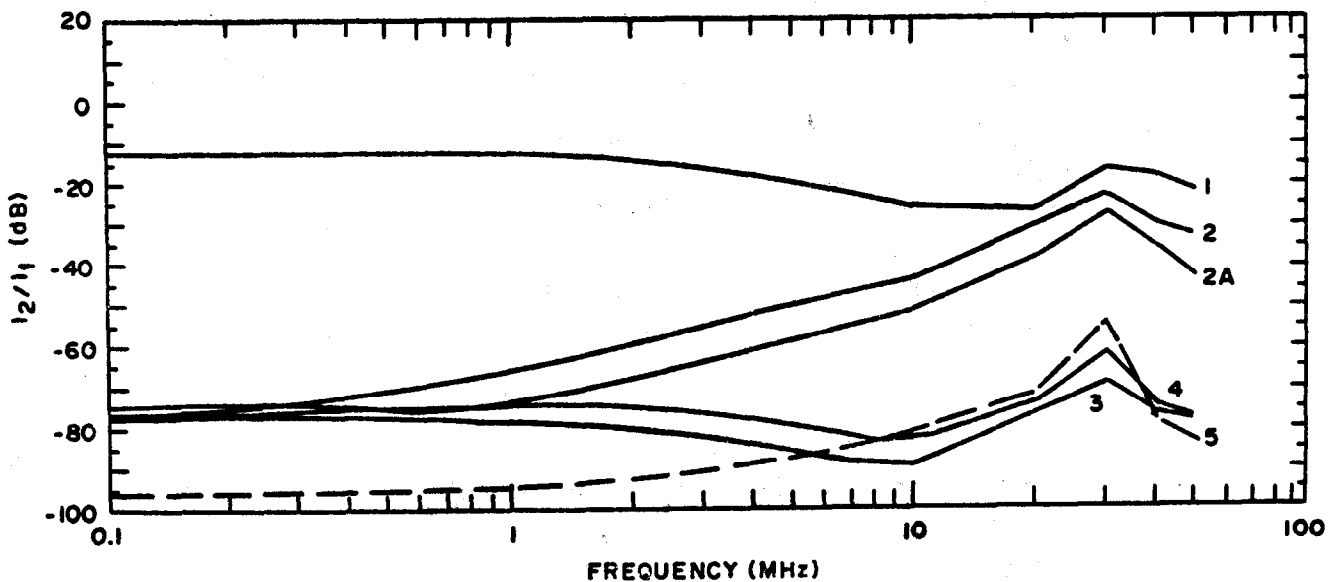
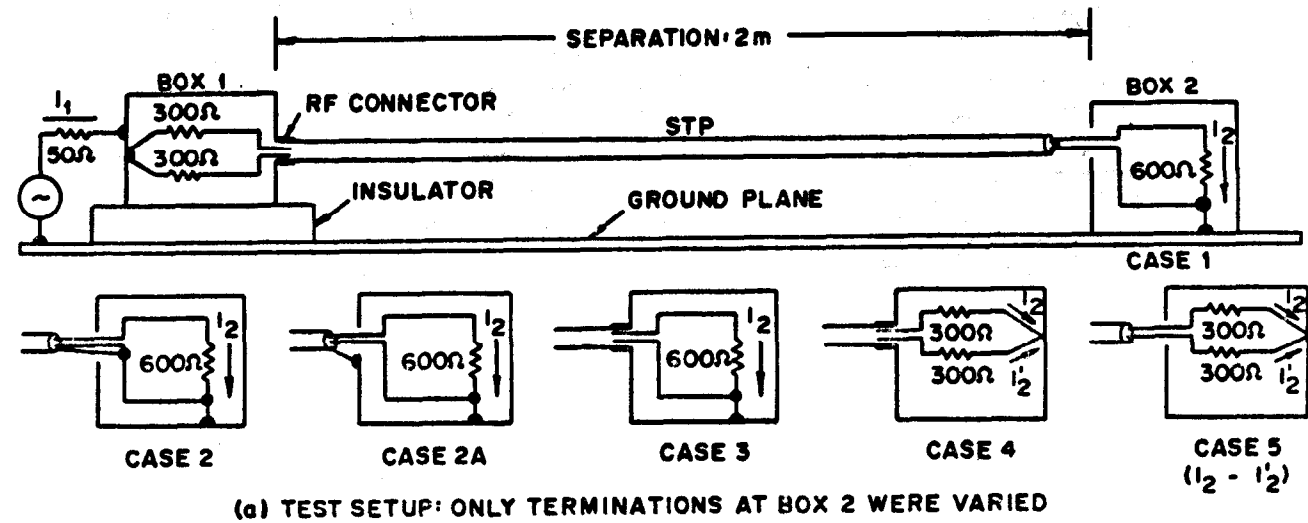


Figure 5-49. Induction loop area for twisted pair cables.
(Source: ref 5-16)

EP 1110-3-2
31 Dec 90

- (1) NO SHIELD TERMINATION
- (2) PIGTAIL, INSIDE
- (2A) PIGTAIL, OUTSIDE
- (3) RF CONNECTOR, UNBALANCED
- (4) RF CONNECTOR, BALANCED
- (5) NORMALIZED DIFFERENTIAL CURRENT
(no shield termination)

(b) NORMALIZED CURRENT I_2 (curve 5 shows the normalized differential current $I_2 - I_2'$)

Figure 5-50. Experiments with shielded twisted pair cabling.
(Source: ref 5-14)

EP 1110-3-2
31 Dec 90

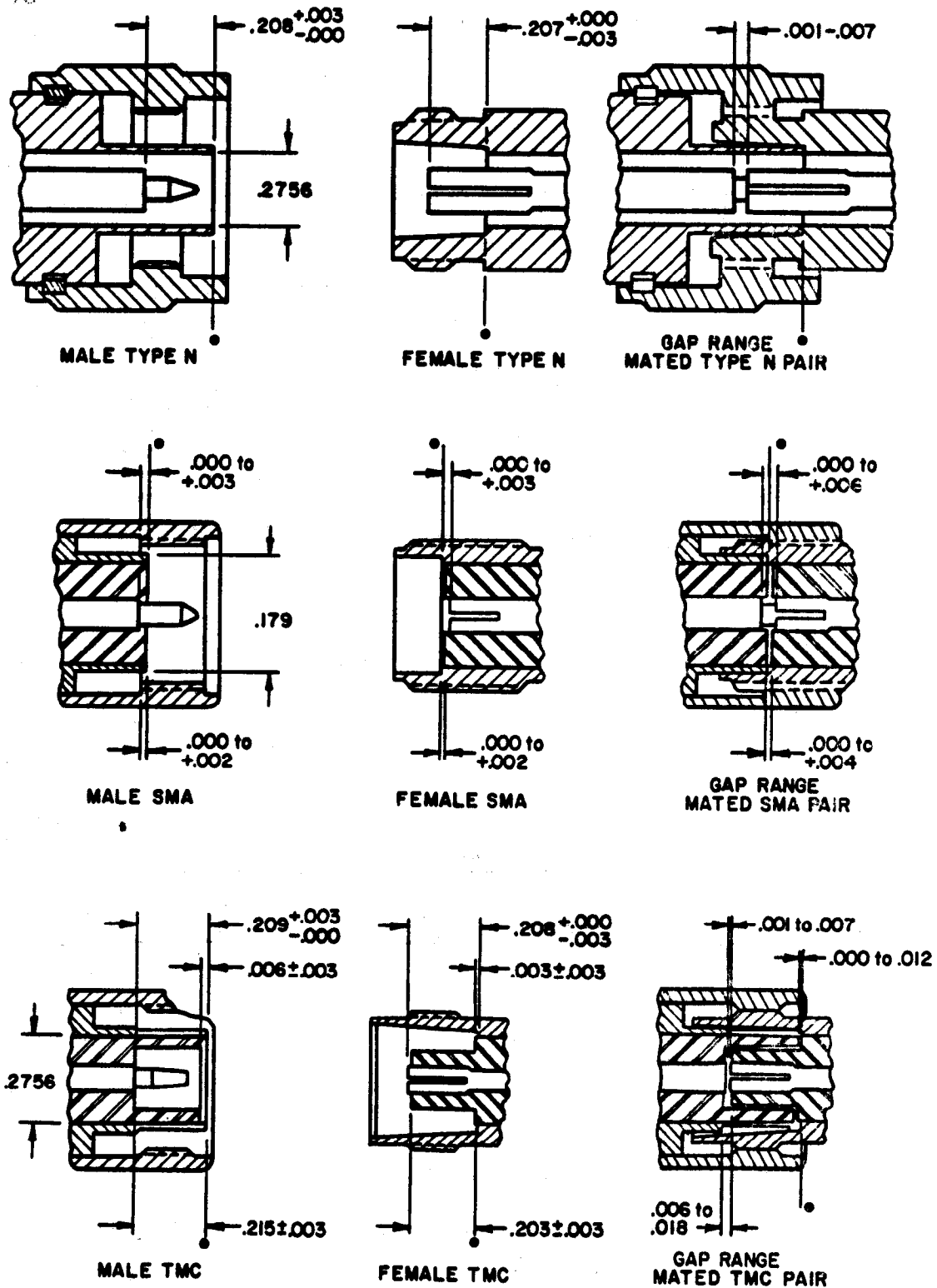


Figure 5-51. Construction of some popular coaxial connectors.
(Source: ref 5-16)

EP 1110-3-2
31 Dec 90

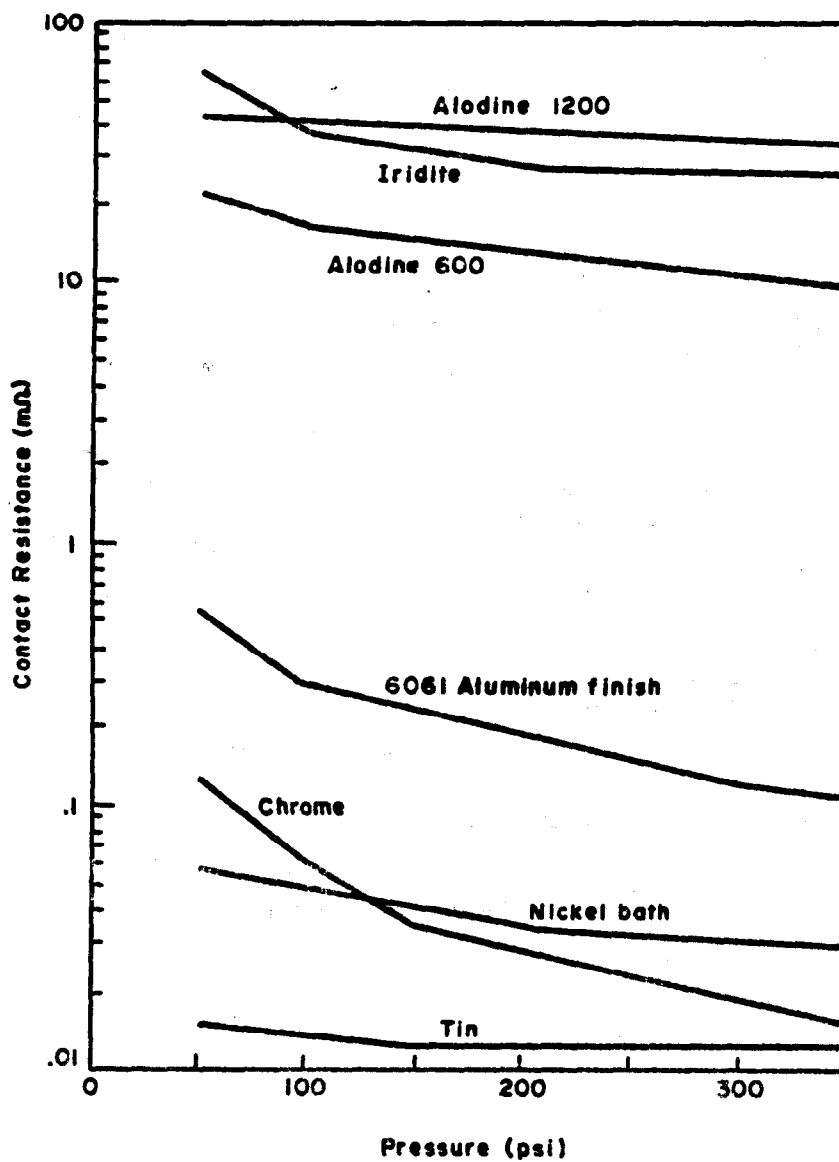


Figure 5-52. Contact resistance of conductive coatings on aluminum.
(Source: ref 5-16)

EP 1110-3-2
31 Dec 90

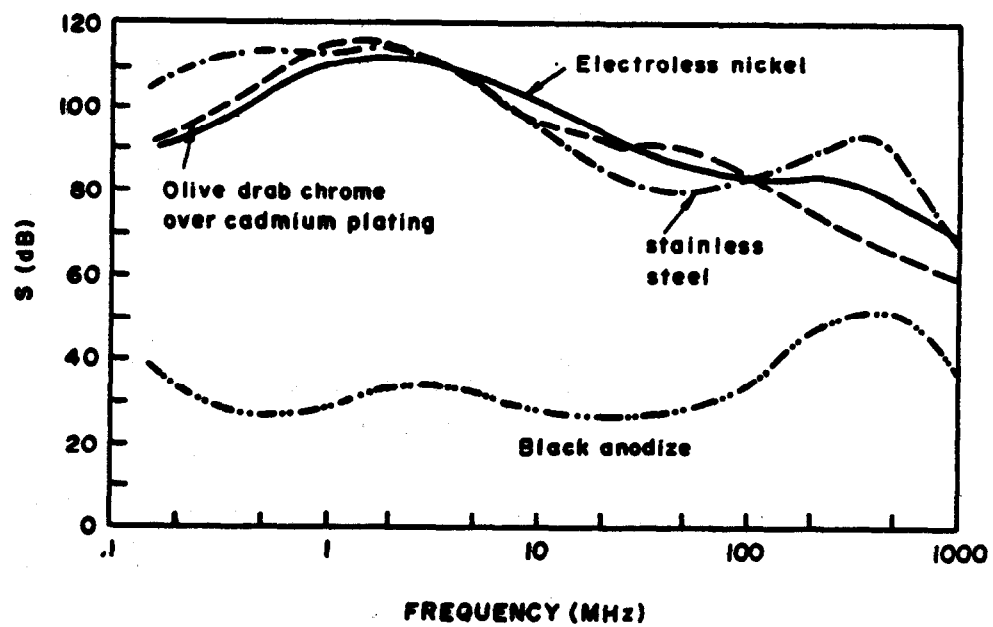


Figure 5-53. Shielding effectiveness of connectors with various finishes.
(Source: ref 5-16)

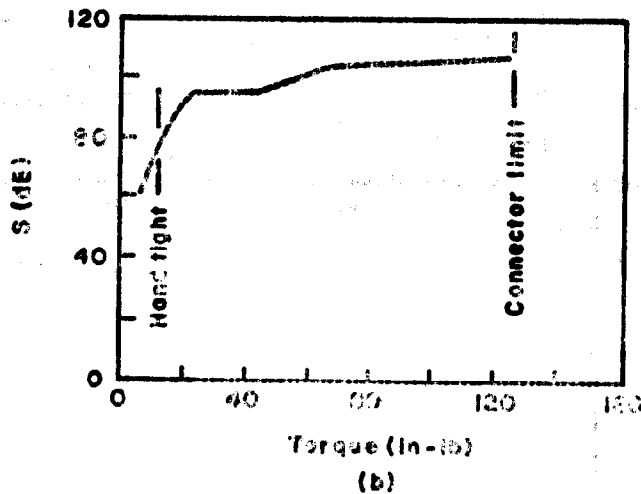
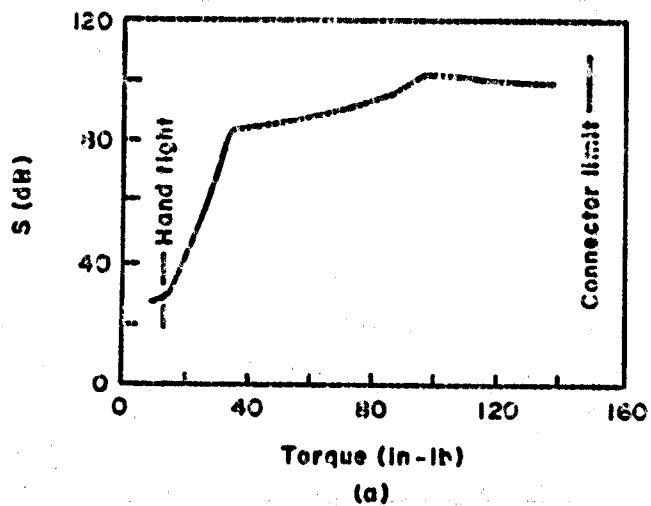


Figure 5-54. Effect of tightening torque on shielding effectiveness during vibration. (Source: ref 5-16)

EP 1110-3-2
31 Dec 90

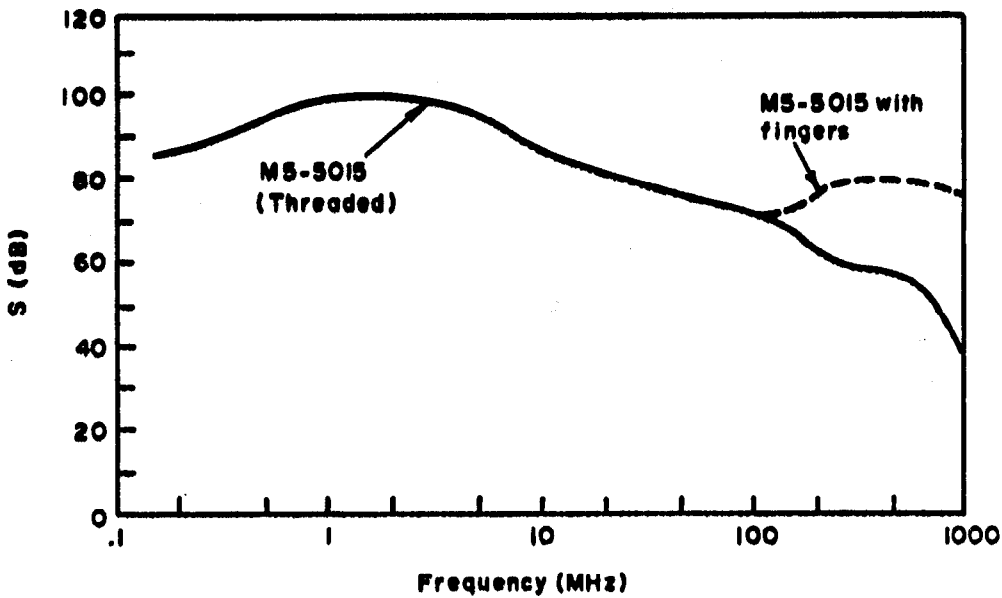
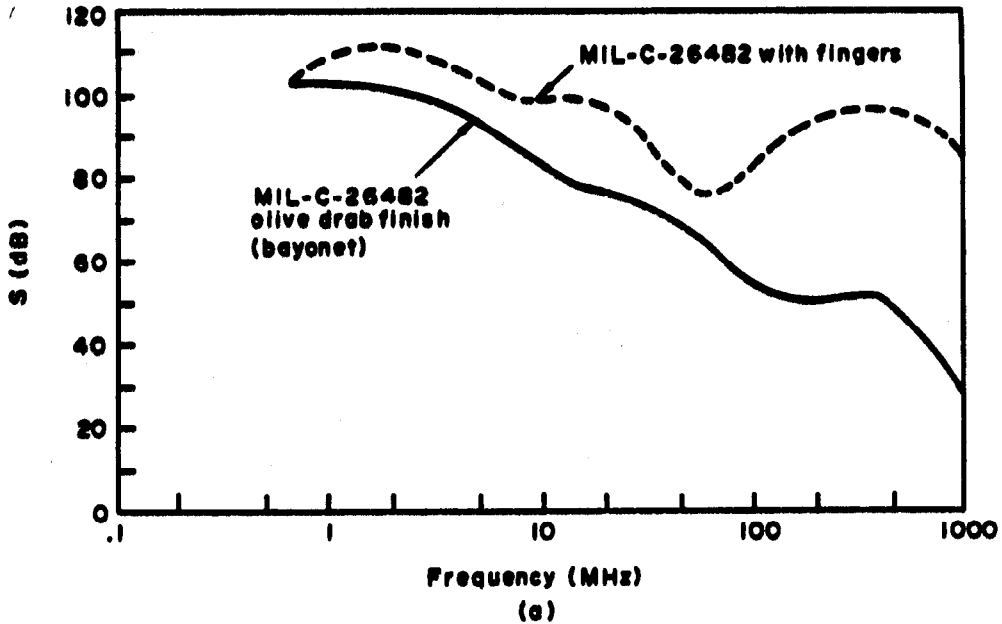


Figure 5-55. Effect of added spring fingers on shielding effectiveness.
(Source: ref 5-16)

EP 1110-3-2
31 Dec 90

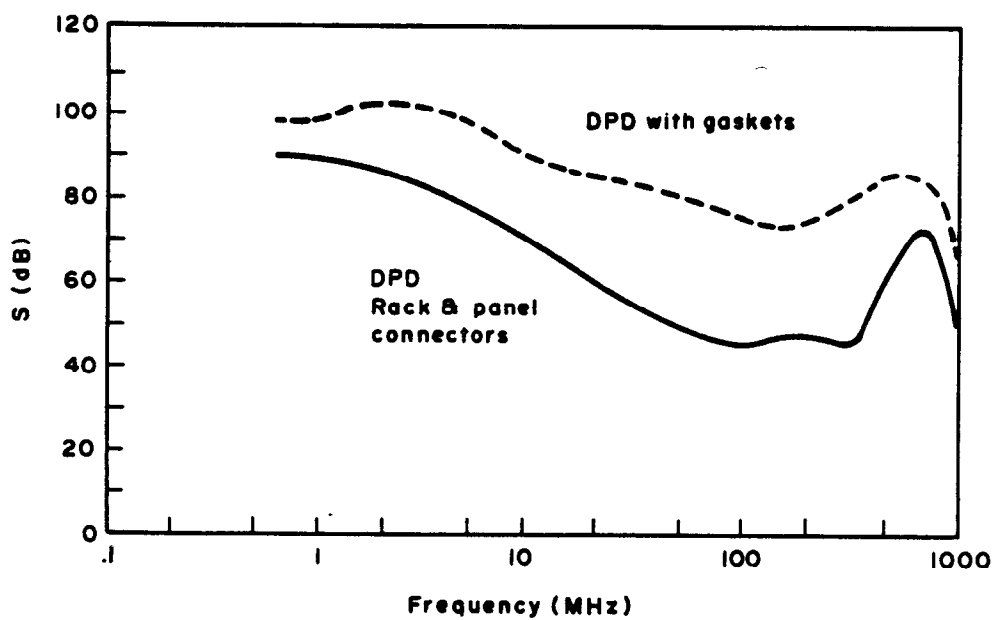


Figure 5-56. Effect of adding shielding gaskets on connector shielding effectiveness. (Source: ref 5-16)

EP 1110-3-2
31 Dec 90

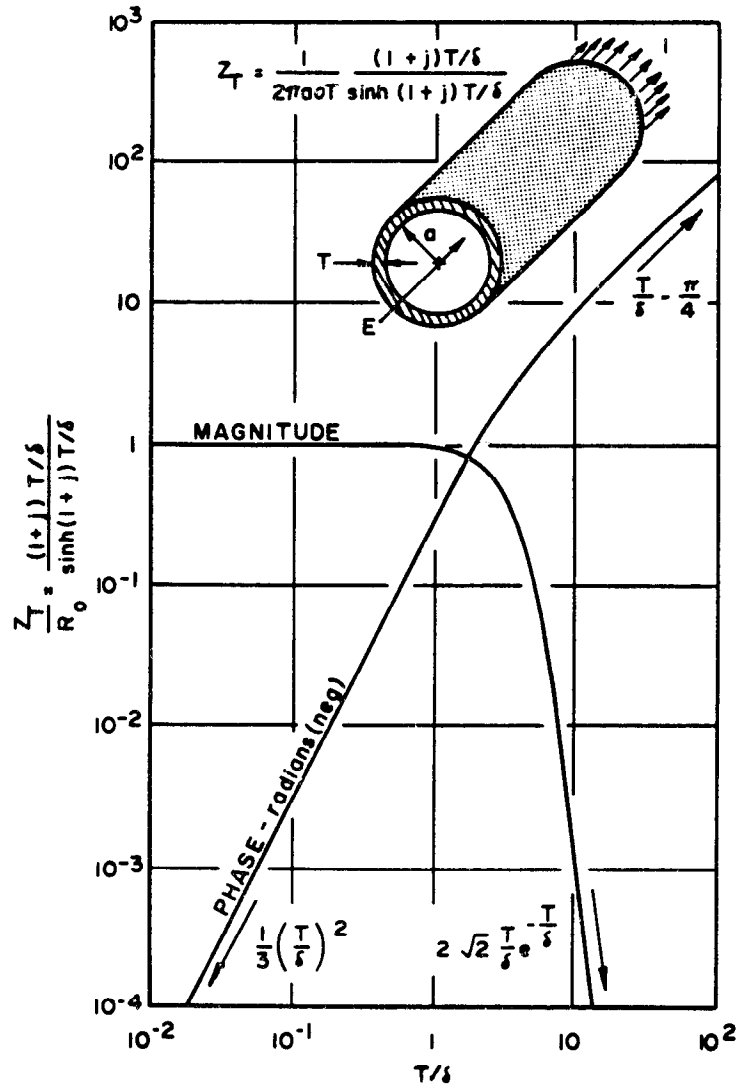


Figure 5-57. Normalized transfer impedance for solid cylindrical shields.
(Source: ref 5-31)

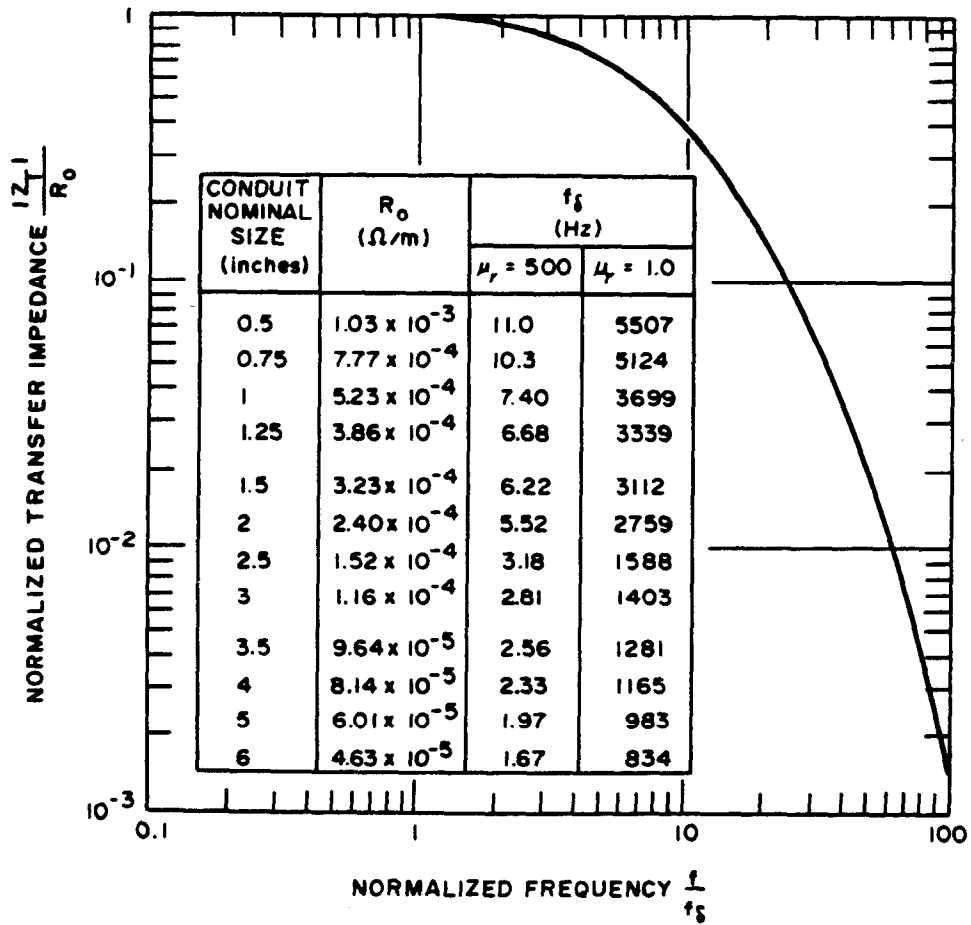
EP 1110-3-2
31 Dec 90

Figure 5-58. Magnitude of the transfer impedance of rigid steel conduit.
(Source: ref 5-31)

EP 1110-3-2
31 Dec 90

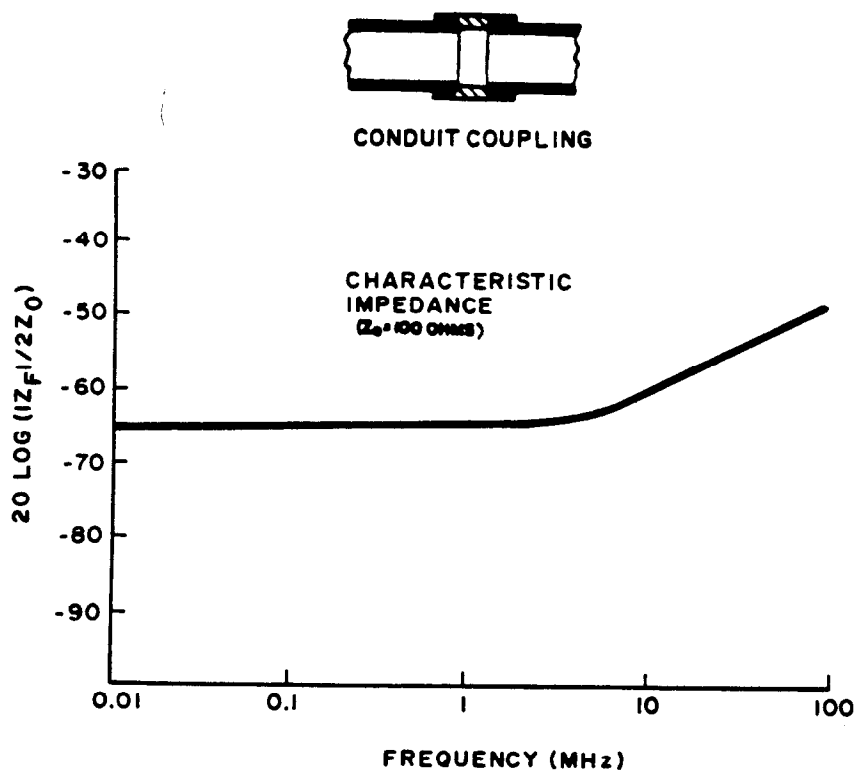
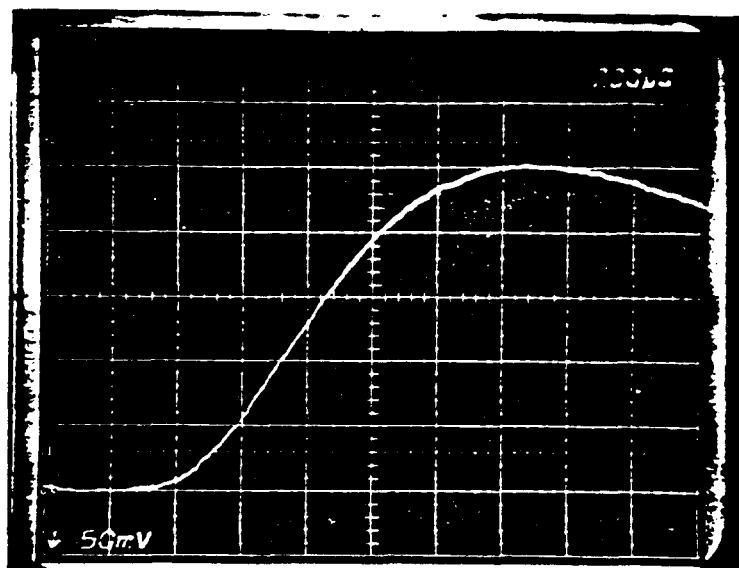
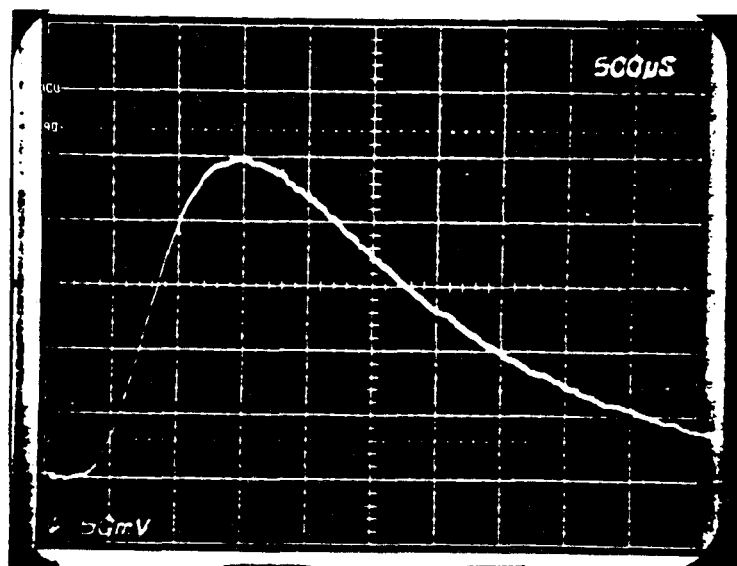


Figure 5-59. Flaw impedance (Z_F) of typical coupling. (Source: ref 5-17)

EP 1110-3-2
31 Dec 90



(a) Vertical: 1000 x 50 mV/div
Horizontal: 200 μ sec/div



(b) Vertical: 1000 x 50 mV/div
Horizontal: 500 μ sec/div

Figure 5-60. Diffusion signal for 1-inch galvanized steel conduit showing sense wire voltage.

EP 1110-3-2
31 Dec 90

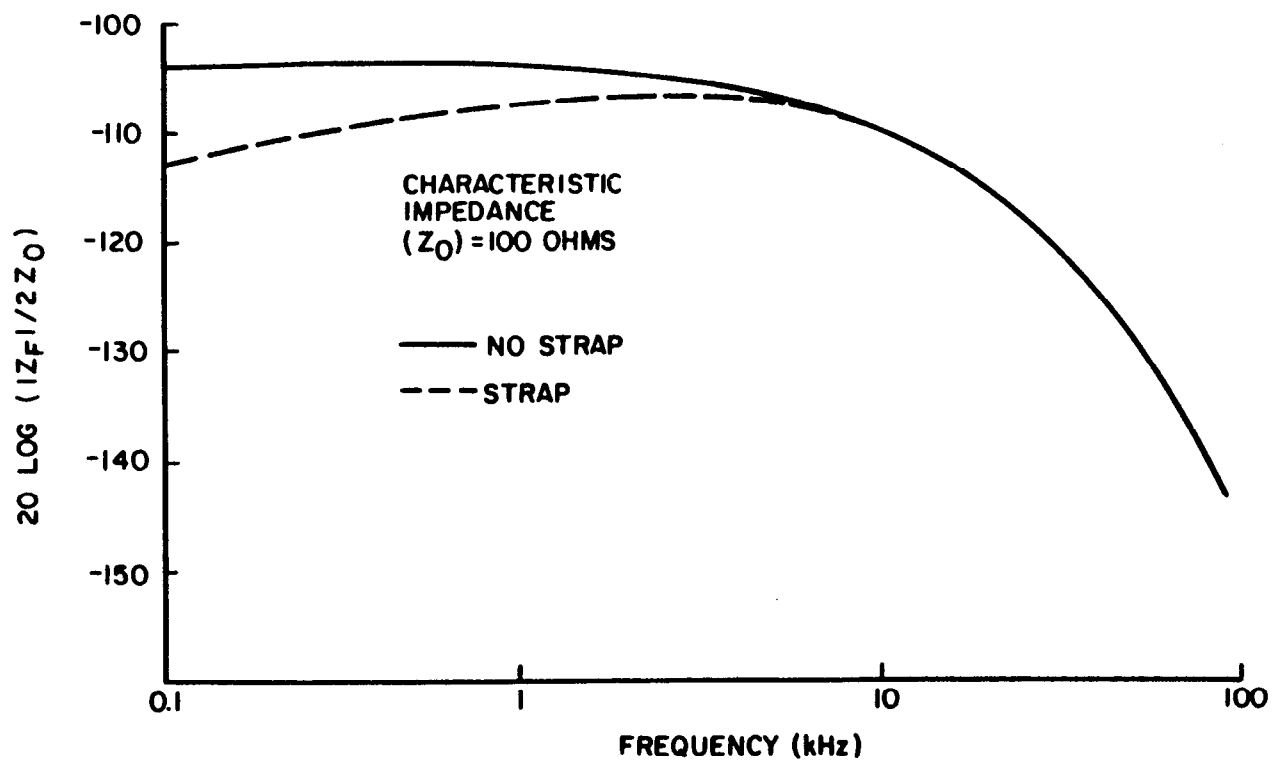


Figure 5-61. Flaw impedance (Z_F) of 0.038-millimeter (0.015-inch) wall flex-joint with and without copper strap. (Source: ref 5-17)

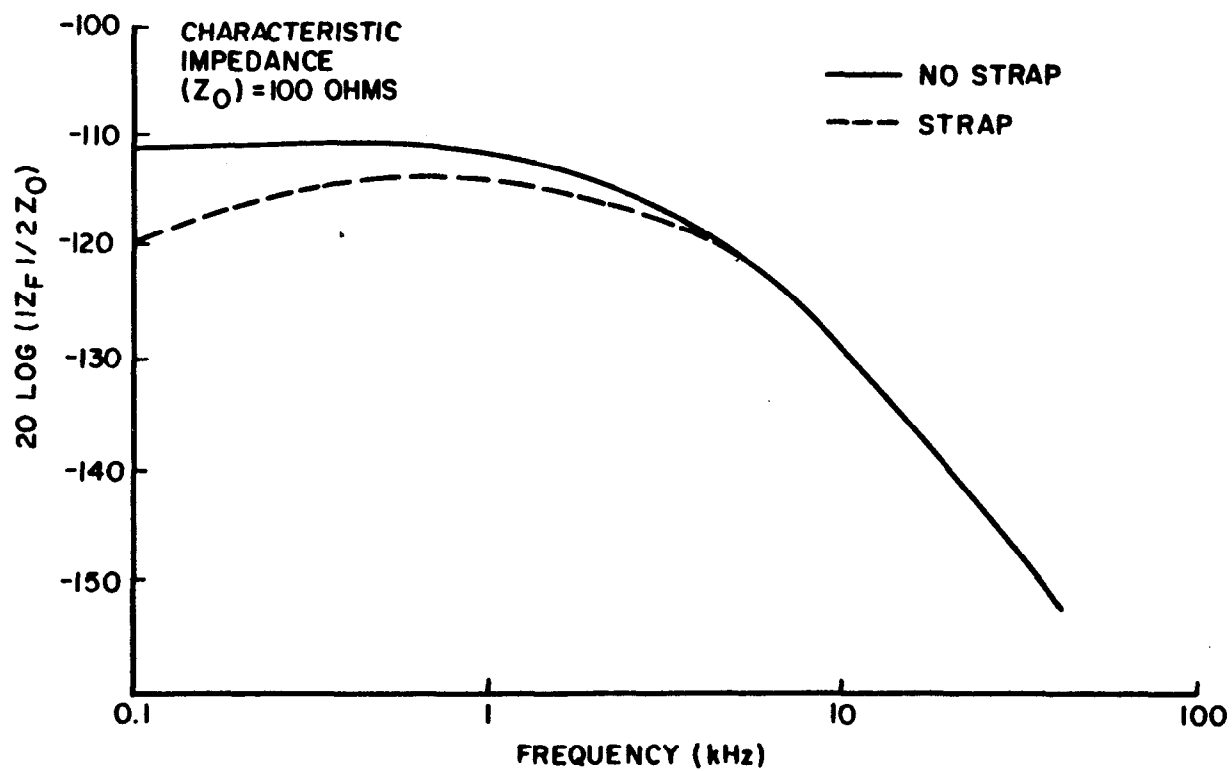
EP 1110-3-2
31 Dec 90

Figure 5-62. Flaw impedance (Z_F) of 0.76-millimeter (0.03-inch) wall flex-joint with and without copper strap. (Source: ref 5-17)

EP 1110-3-2
31 Dec 90

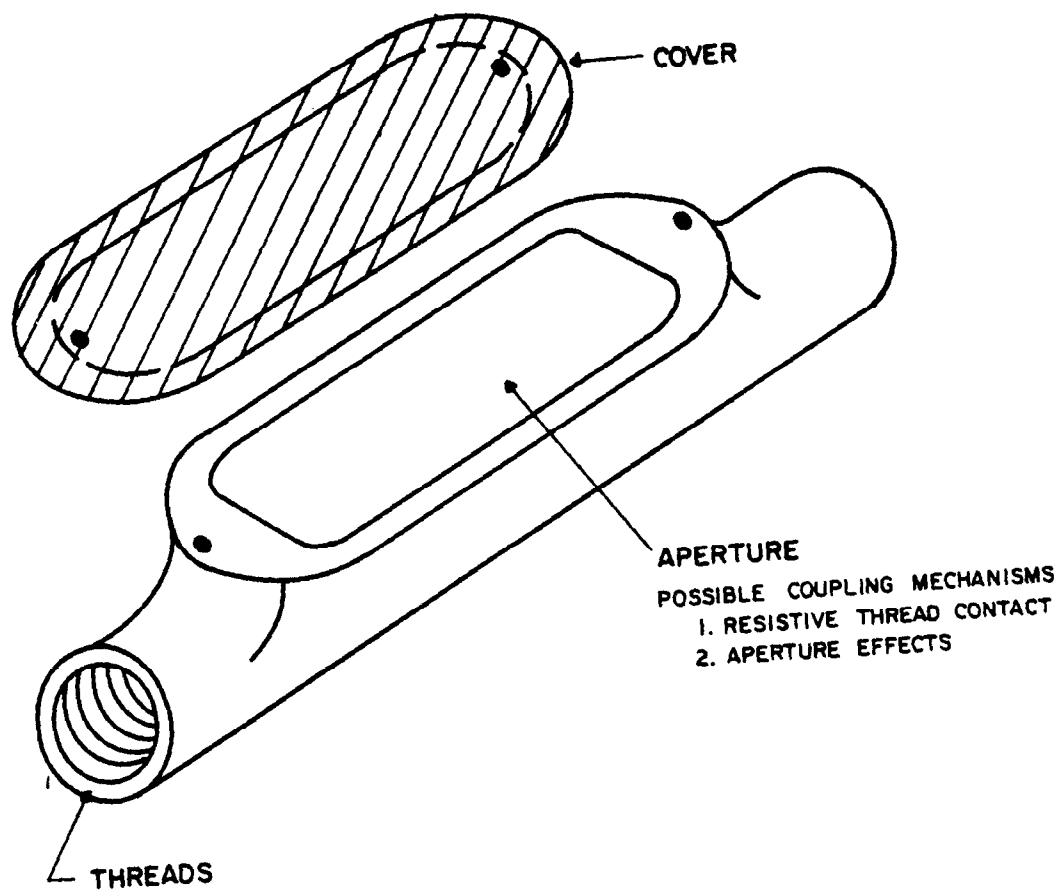


Figure 5-64. Type C conduit body. (Source: ref 5-17)

EP 1110-3-2
31 Dec 90

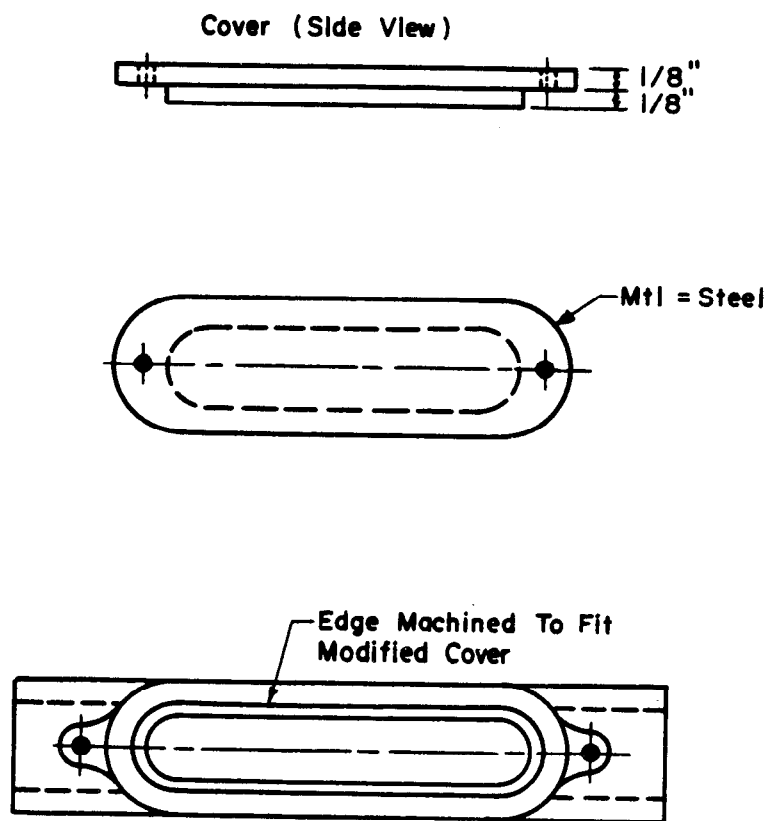


Figure 5-65. Machined conduit body cover for HEMP hardening.
(Source: ref 5-17)

EP 1110-3-2
31 Dec 90

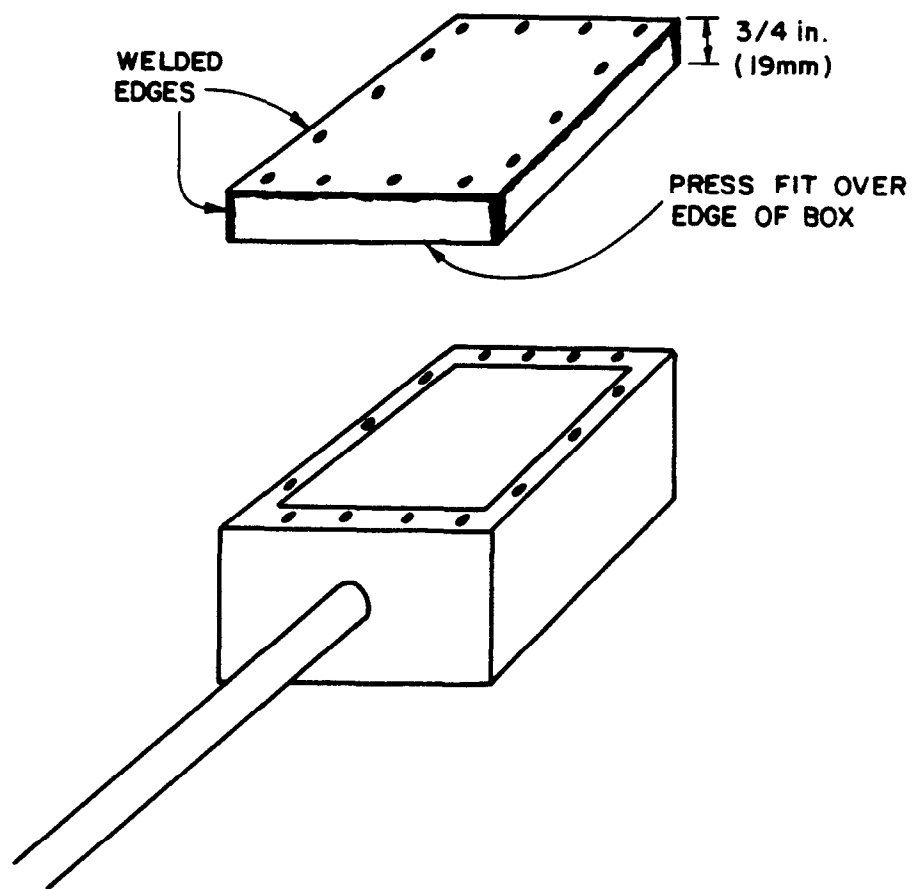


Figure 5-66. "Wrap-around" junction box cover. (Source: ref 5-17)

EP 1110-3-2
31 Dec 90

This page not used.

EP 1110-3-2
31 Dec 90

This page not used.

EP 1110-3-2
31 Dec 90

This page not used.

EP 1110-3-2
31 Dec 90

This page not used.

EP 1110-3-2
31 Dec 90

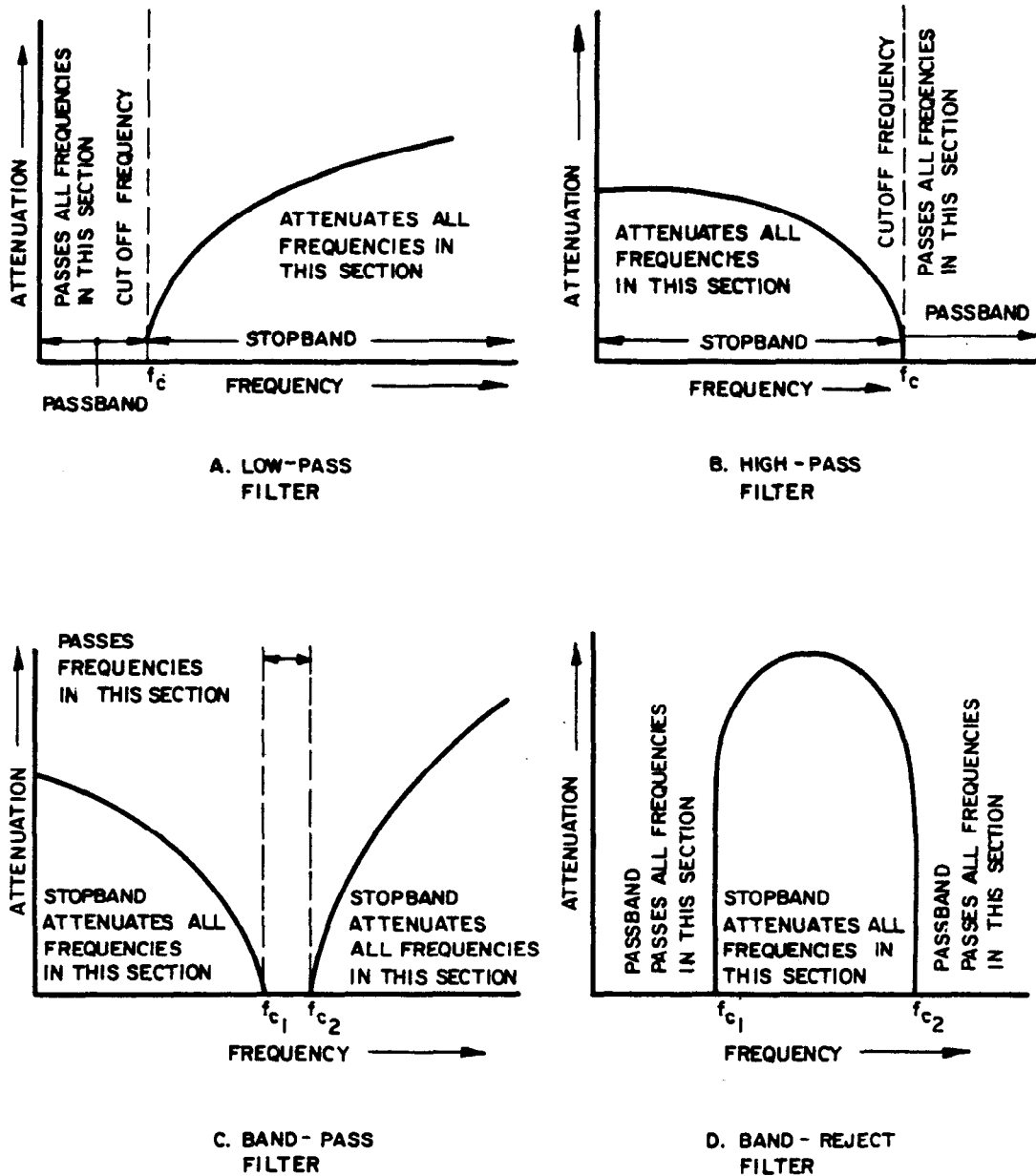


Figure 5-71. The four basic filter classes. (Source: ref 5-30)

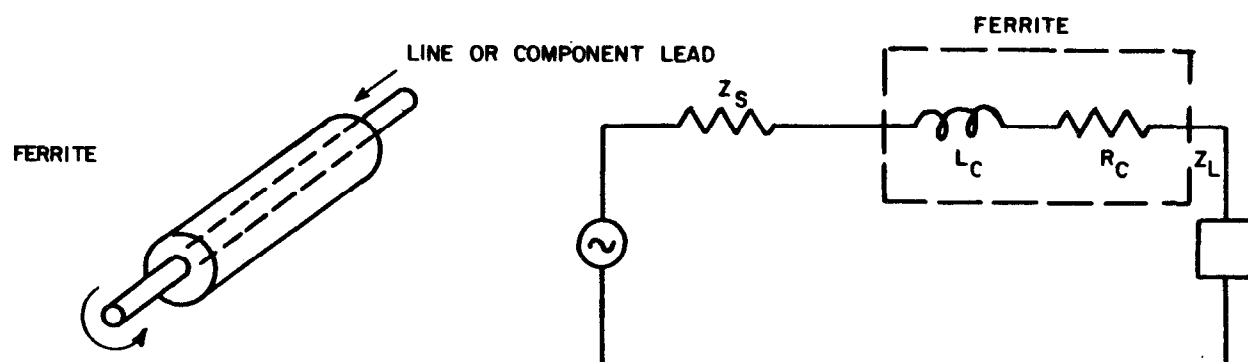
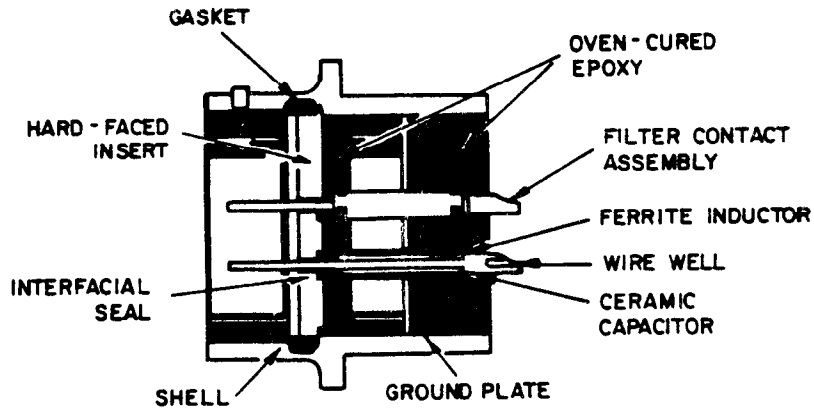
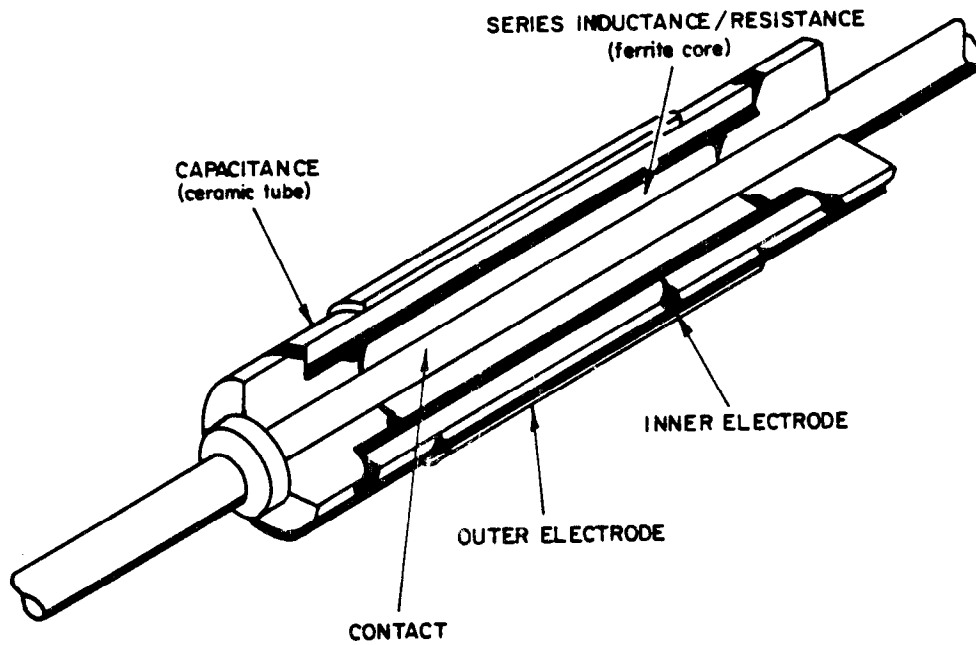
EP 1110-3-2
31 Dec 90

Figure 5-72. Ferrite bead on wire and ferrite bead equivalent circuit.
(Source: ref 5-32)

EP 1110-3-2
31 Dec 90



INTERNAL CONSTRUCTION OF A FILTER-PIN CONNECTOR
CONTAINING PASSIVE ELEMENTS



FILTER-PIN CONSTRUCTION CONTAINING PASSIVE ELEMENTS

Figure 5-73. Filter pin connector design. (Source: ref 5-7)

EP 1110-3-2
31 Dec 90

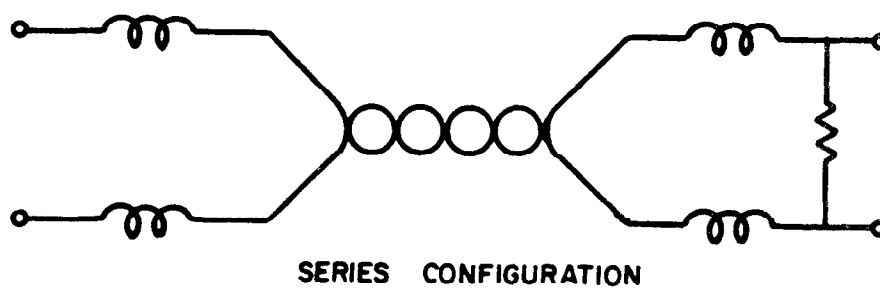
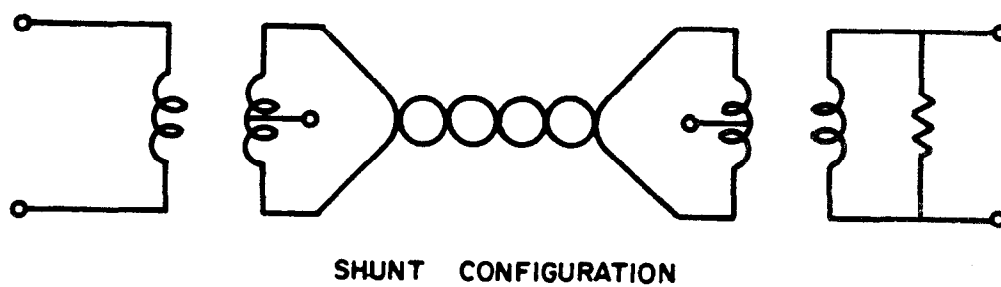


Figure 5-74. Shunt and series transformer wiring configuration.
(Source: ref 5-32)

EP 1110-3-2
31 Dec 90

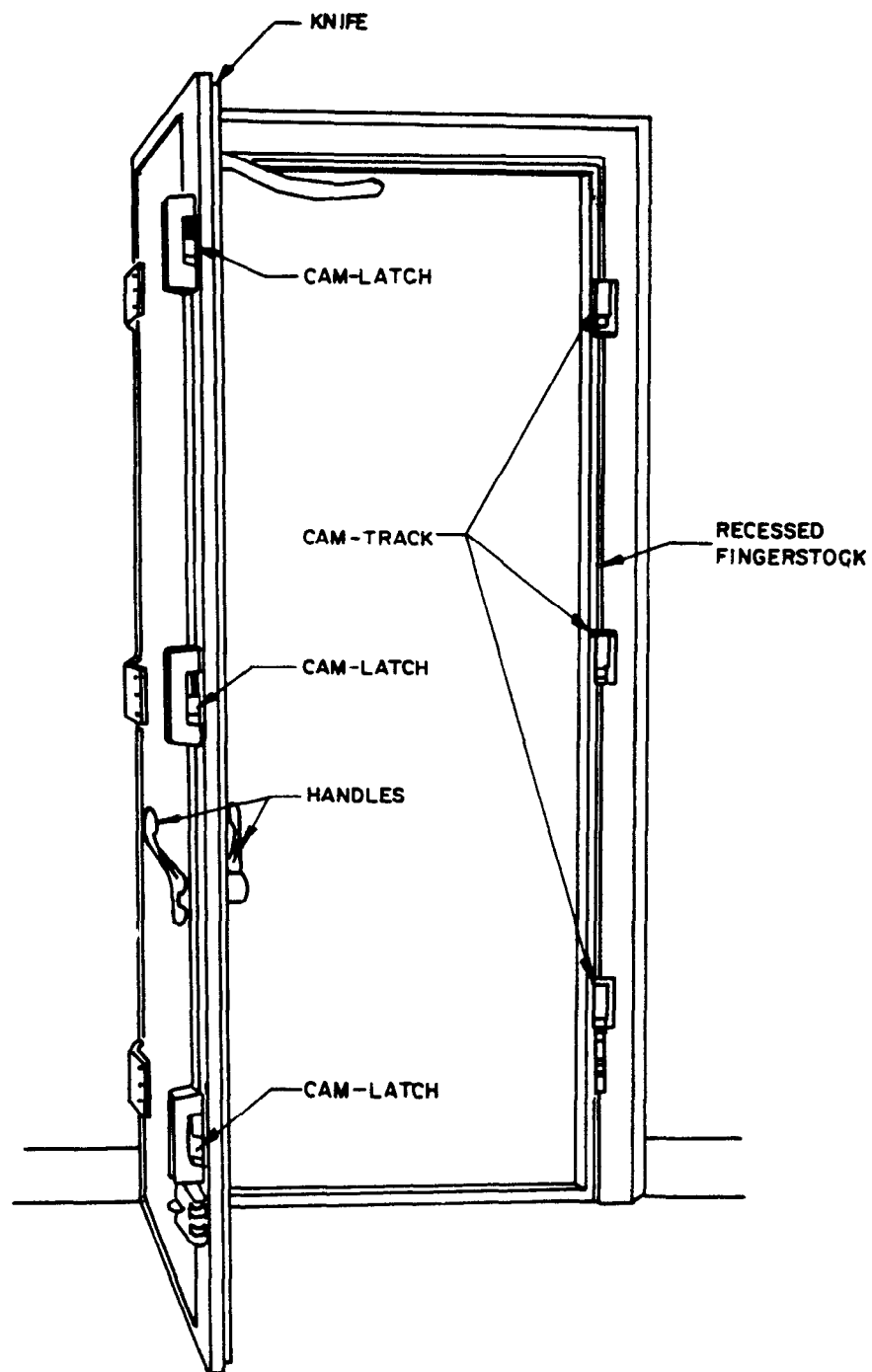
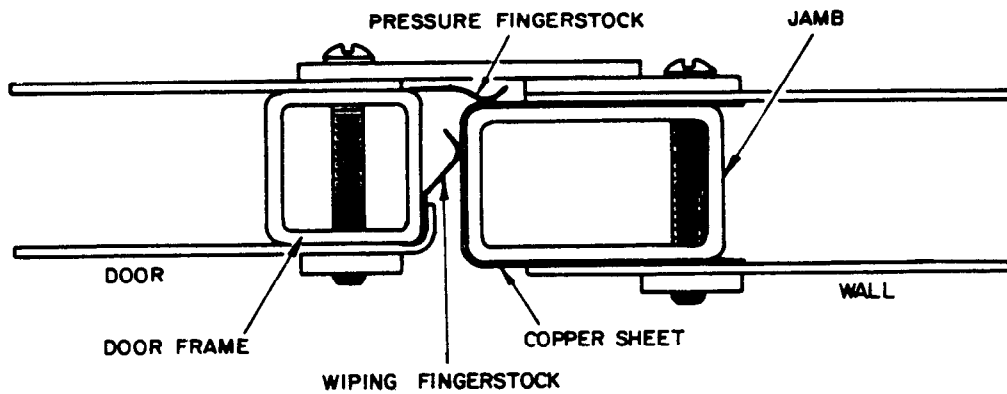
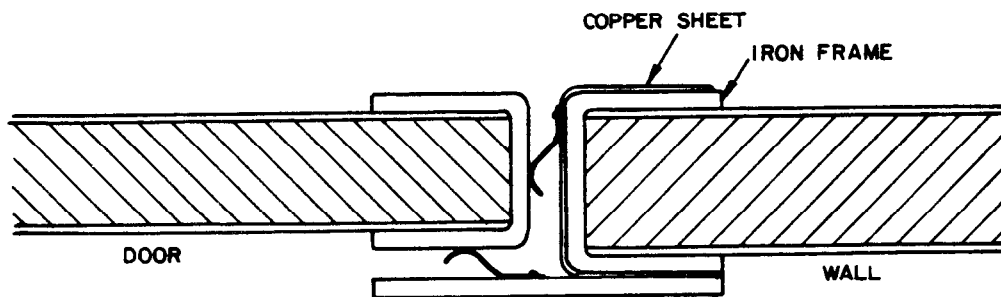


Figure 5-75. Typical shielded door closures. (sheet 1 of 2)

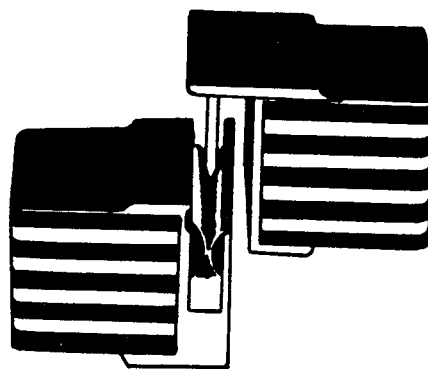
EP 1110-3-2
31 Dec 90



(a)



(b)



(c)

Figure 5-75. Typical shielded door closures. (sheet 2 of 2)

EP 1110-3-2
31 Dec 90

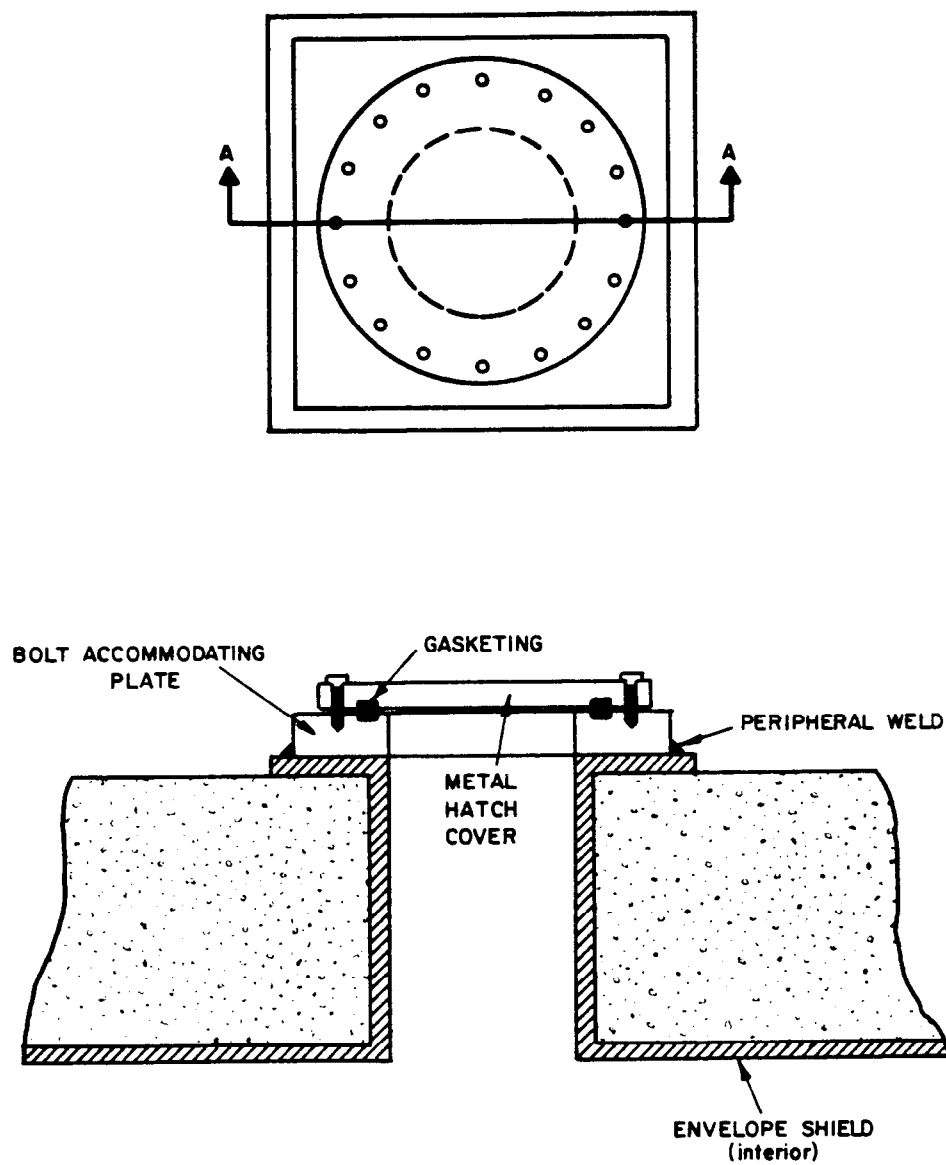


Figure 5-76. Emergency escape hatch configuration. (Source: ref 5-7)

EP 1110-3-2
31 Dec 90

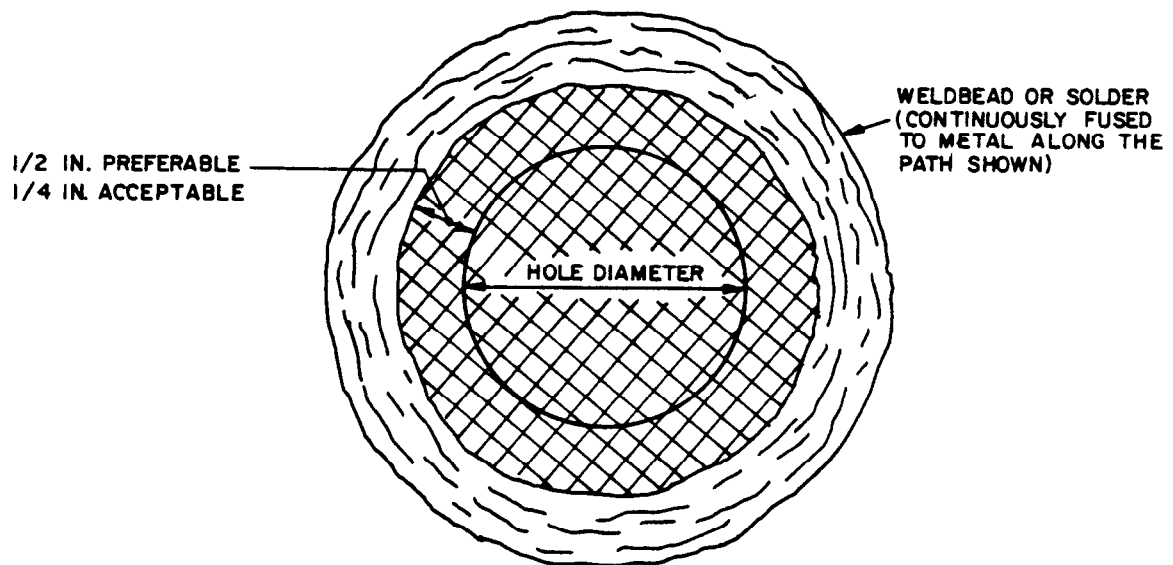


Figure 5-77. Typical welded screen installation over a ventilation aperture.
(Source: ref 5-3)

EP 1110-3-2
31 Dec 90

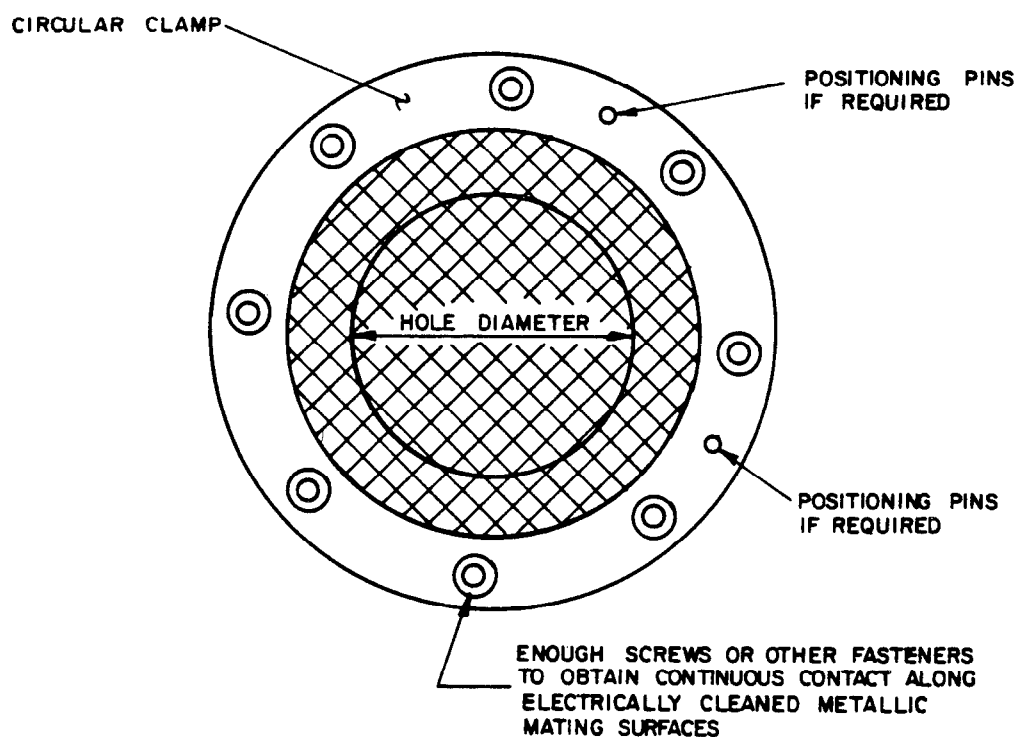


Figure 5-78. Typical clamped screen installation over a ventilation aperture.
(Source: ref 5-3)

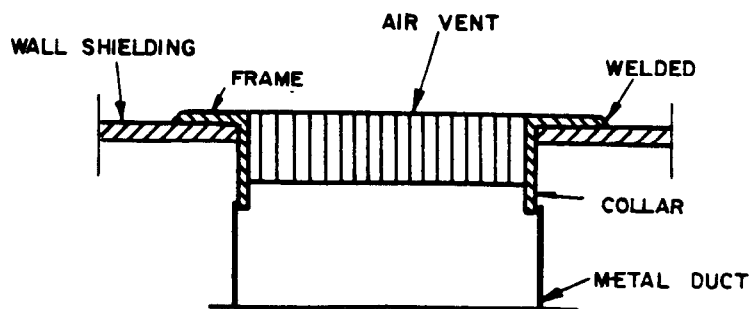
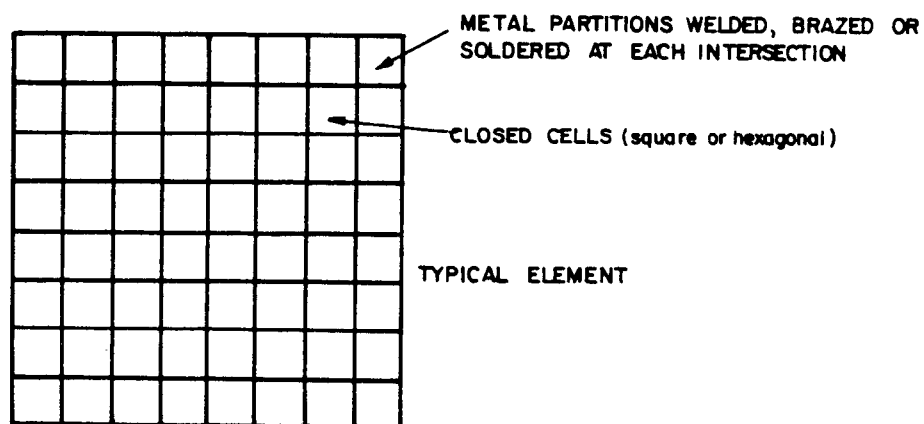


Figure 5-79. Honeycomb material for shielding air vents. (Source: ref 5-7)

EP 1110-3-2
31 Dec 90

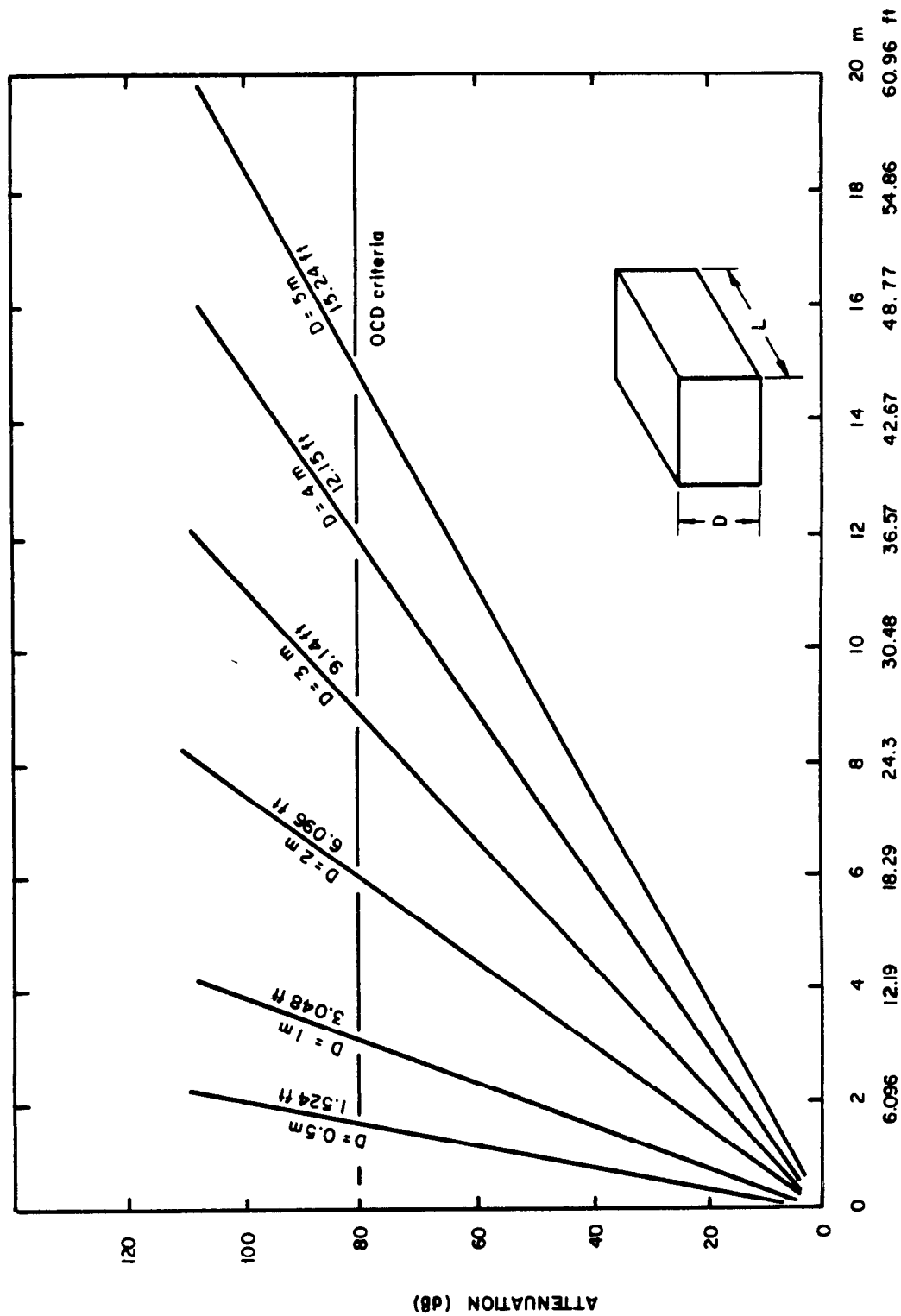


Figure 5-80. Waveguide attenuation as a function of waveguide dimensions.
(Source: ref 5-28)

EP 1110-3-2
31 Dec 90

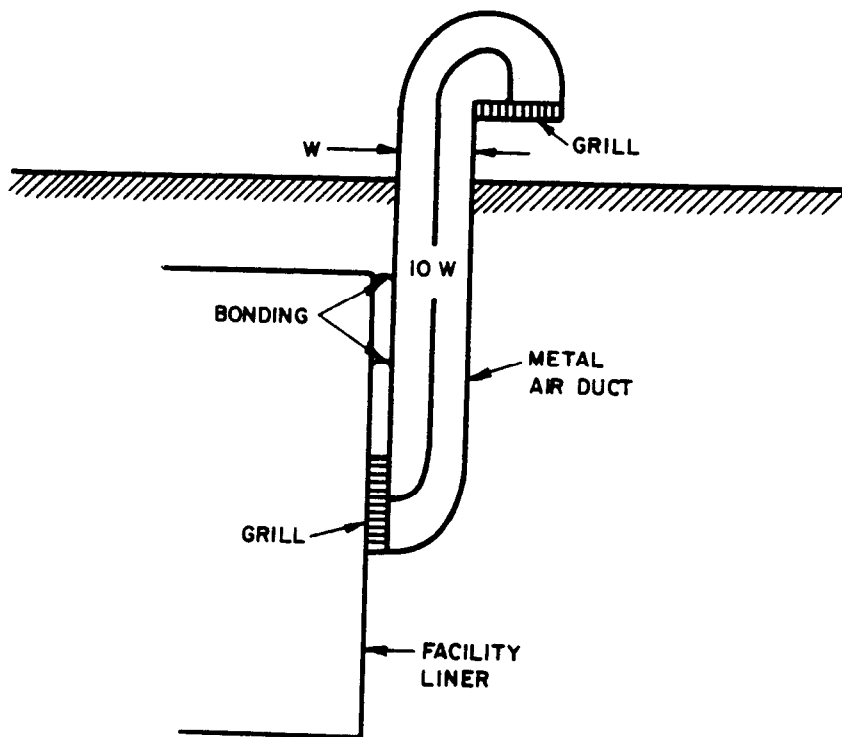


Figure 5-81. Air vent HEMP protection design. (Source: ref 5-7)

EP 1110-3-2
31 Dec 90

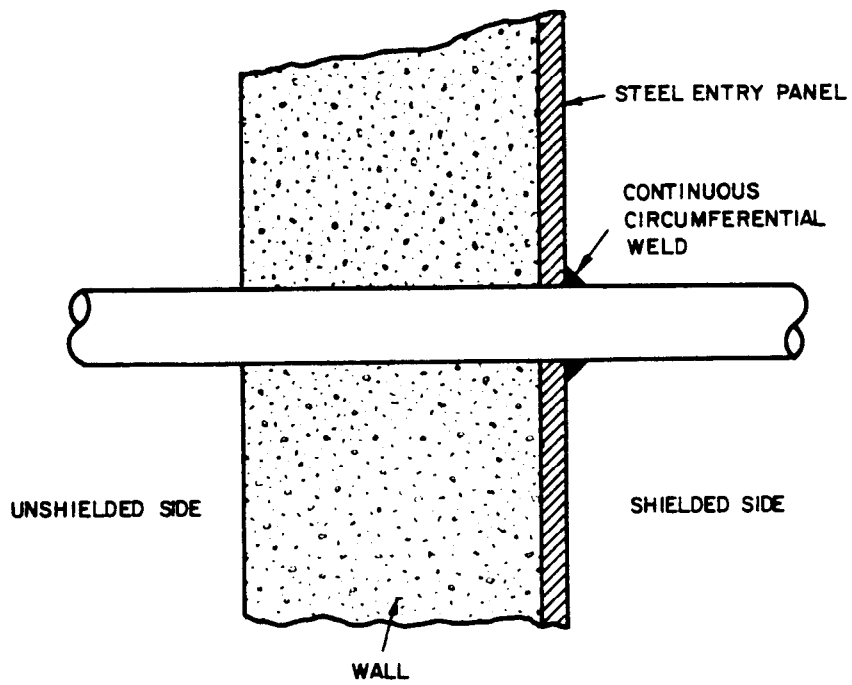


Figure 5-82. Conduit or metal pipe penetration design. (Source: ref 5-7)

EP 1110-3-2
31 Dec 90

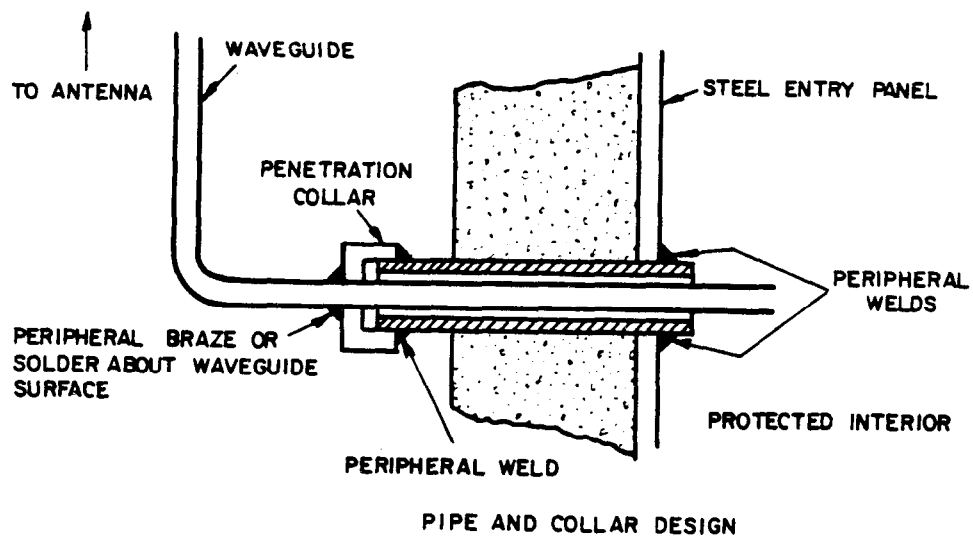
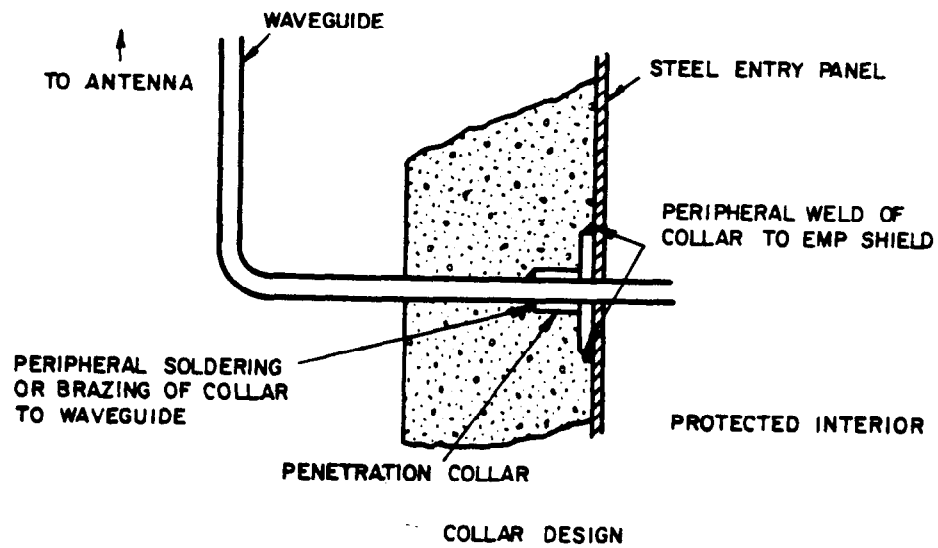
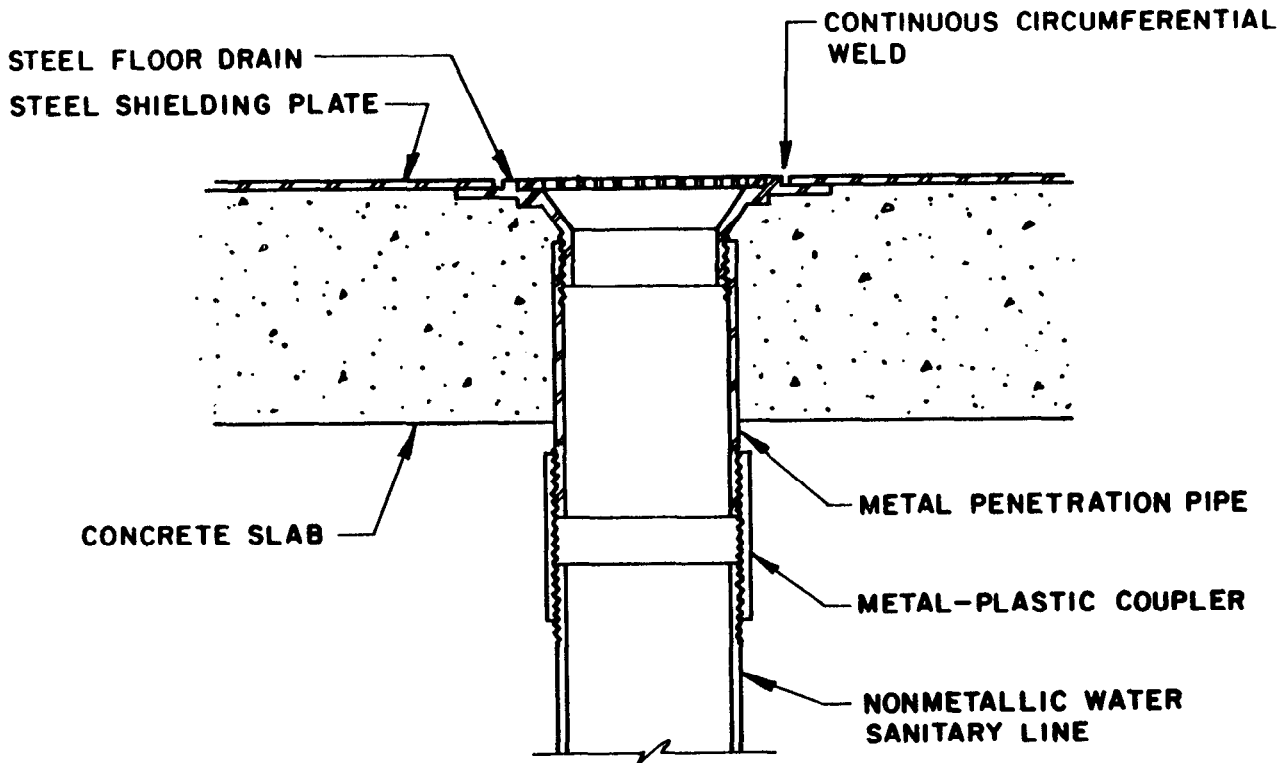


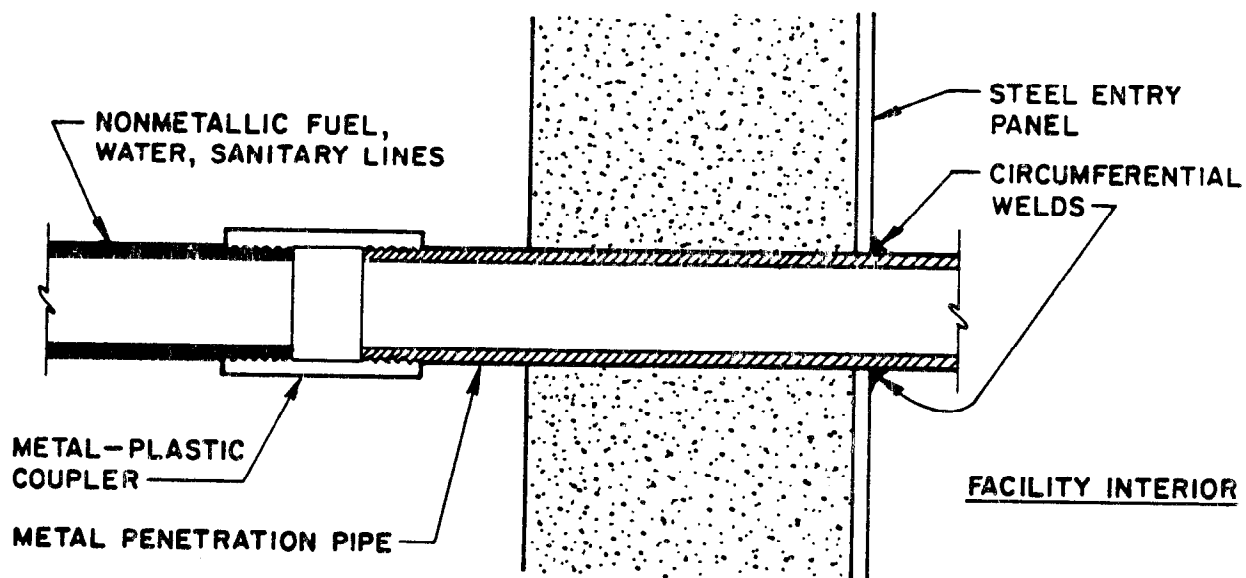
Figure 5-83. HEMP protection for waveguide entry. (Source: ref 5-7)

EP 1110-3-2
31 Dec 90

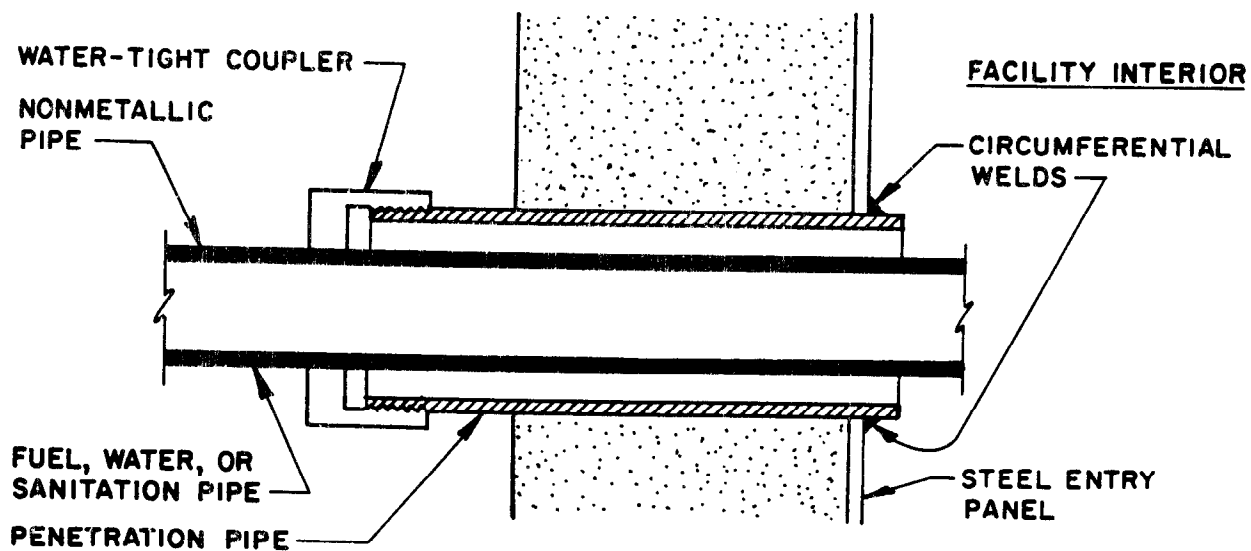


FLOOR DRAIN AND PIPE PENETRATION

Figure 5-84. Plastic pipe termination practices. (Source: ref 5-7)
(sheet 1 of 2)



PIPE TERMINATION



PIPE FEEDTHROUGH

Figure 5-84. Plastic pipe termination practices. (Source: ref 5-7)
(sheet 2 of 2)

EP 1110-3-2
31 Dec 90

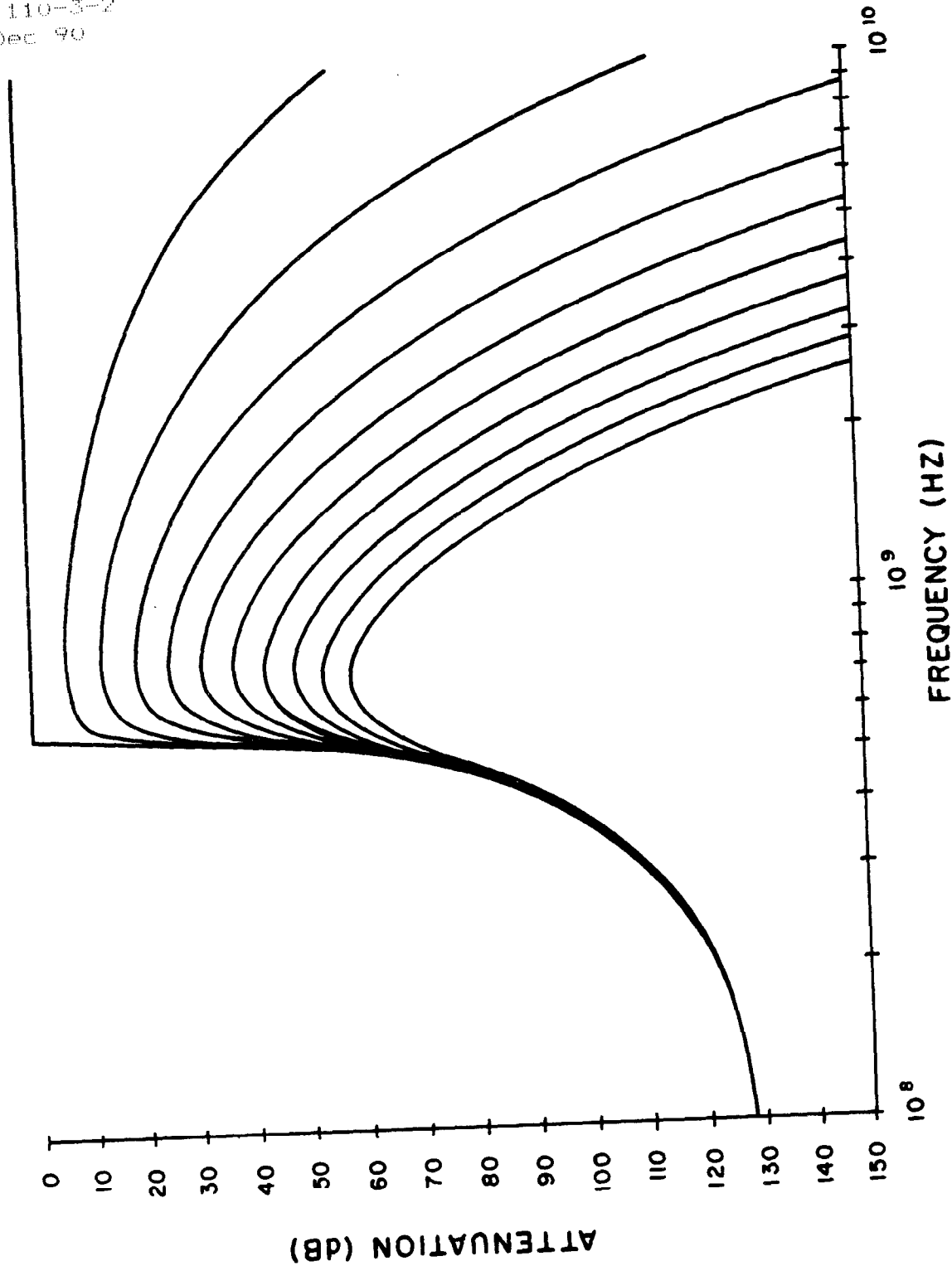


Figure 5-85. Theoretical attenuation of the TE₁₁ mode for a 1.5-inch (3.8-centimeter) internal diameter pipe with distilled water for various loss tangents. (Source: ref 5-20)

EP 1110-3-2
31 Dec 90

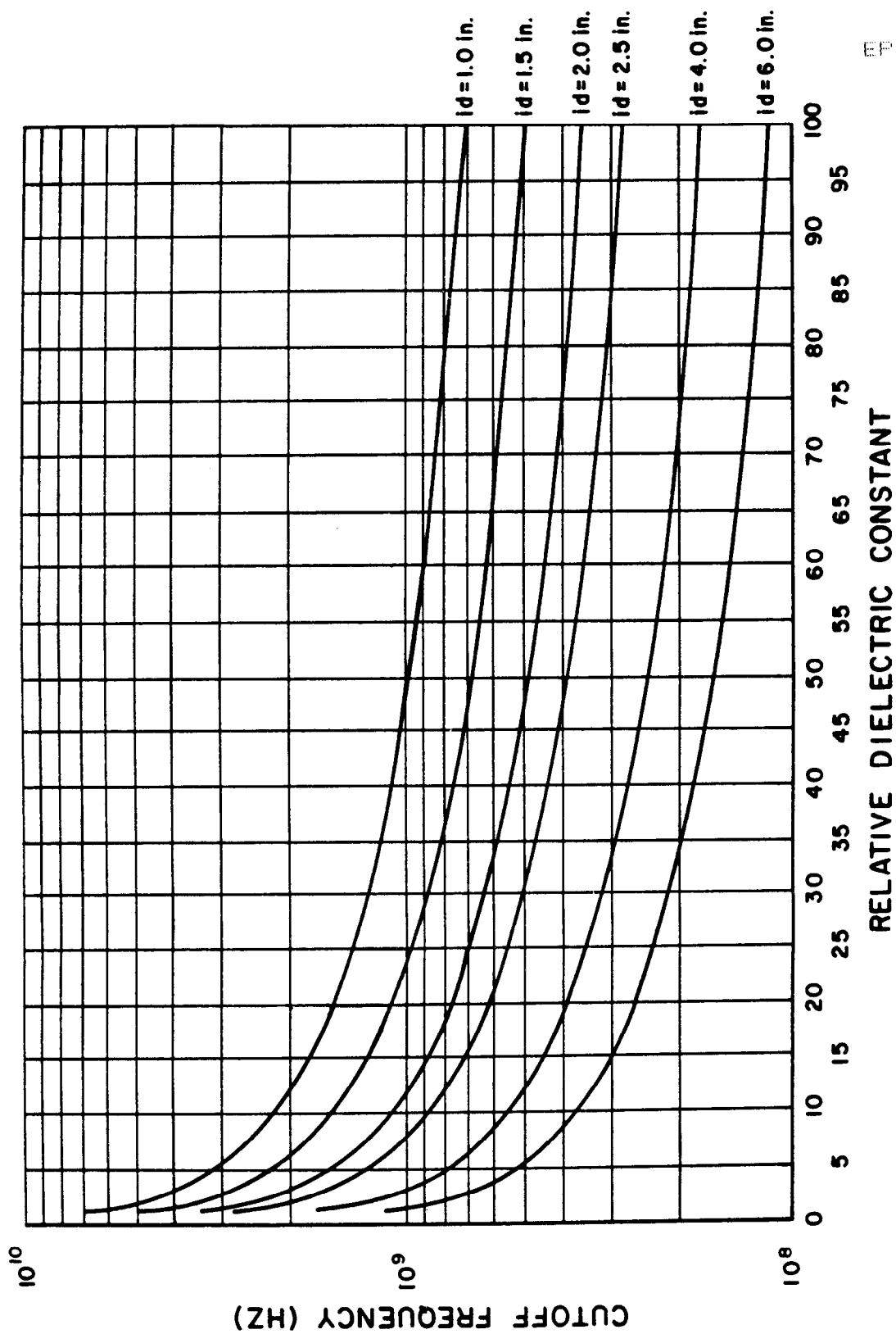


Figure 5-86. Cutoff frequency versus relative dielectric constant for various pipe diameters. (Source: ref 5-20)

EP 1110-3-2
31 Dec 90

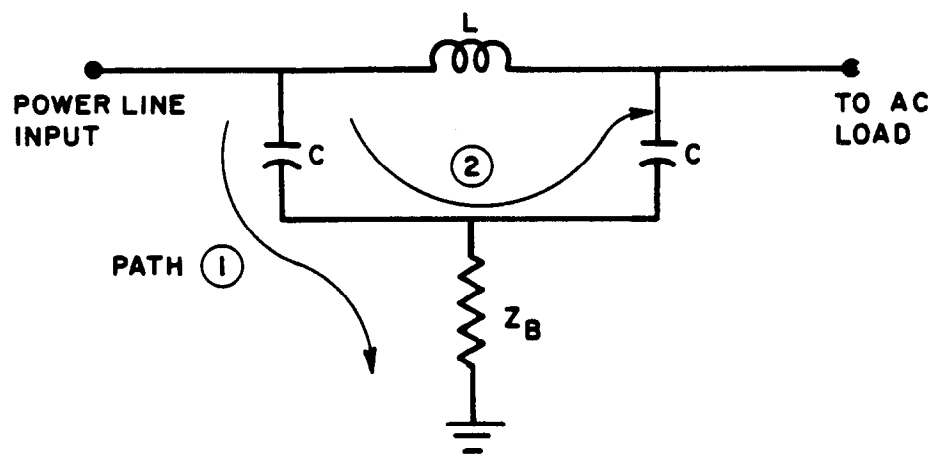


Figure 5-87. Effects of poor bonding on the performance of a power line filter. (Source: ref 5-6)

EP 1110-3-2
31 Dec 90

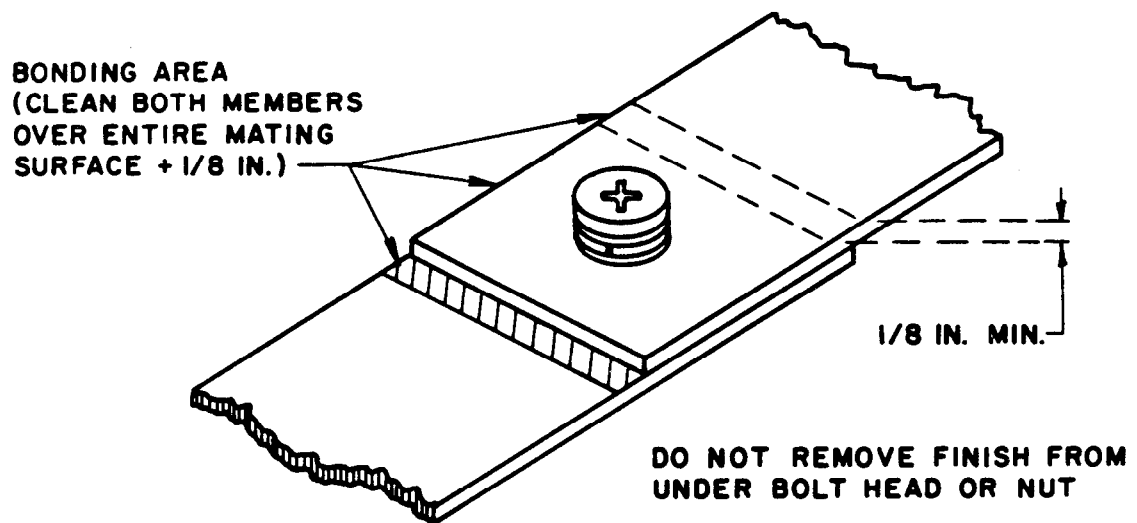


Figure 5-88. Bolted bond between flat bars. (Source: ref 5-6)

EP 1110-3-2
31 Dec 90

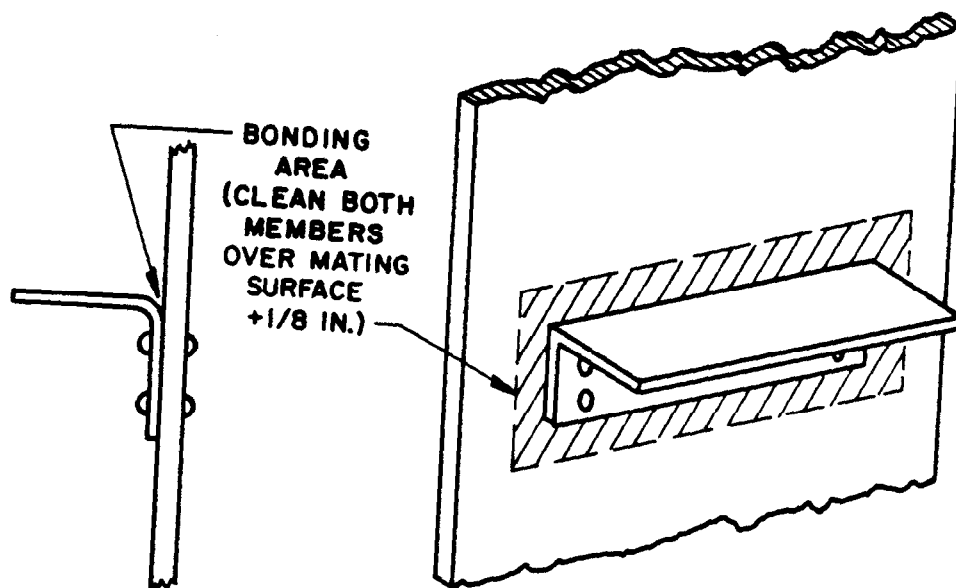


Figure 5-89. Bracket installation (bolt). (Source: ref 5-6)

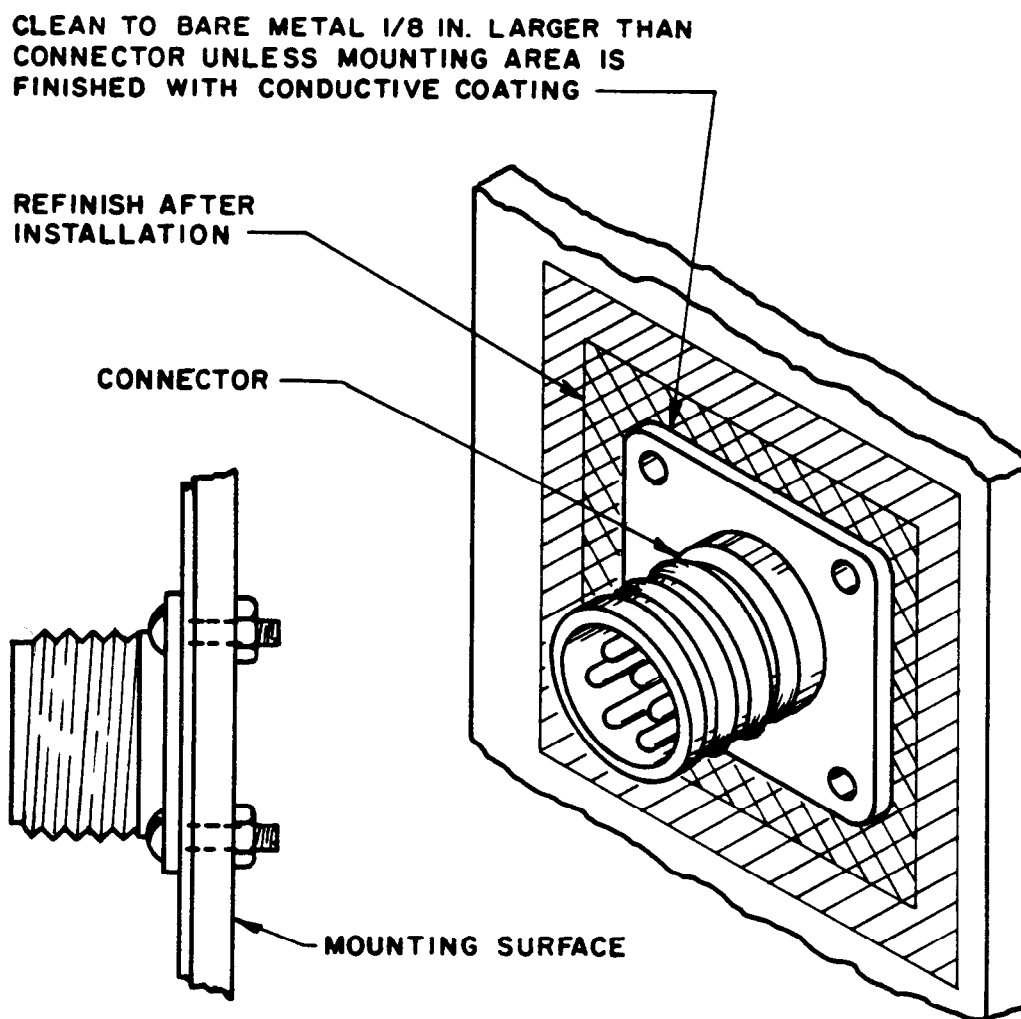


Figure 5-90. Bonding of connector to mounting surface. (Source: ref 5-6)

EP 1110-3-2
31 Dec 90

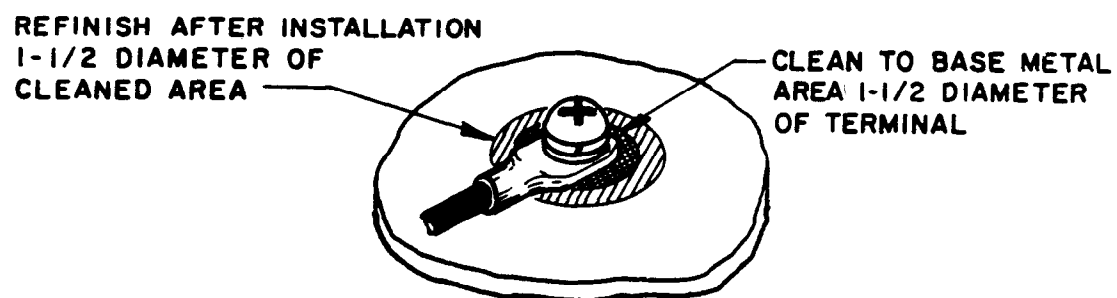


Figure 5-91. Bolting of bonding jumpers to flat surface. (Source: ref 5-6)

EP 1110-3-2
31 Dec 90

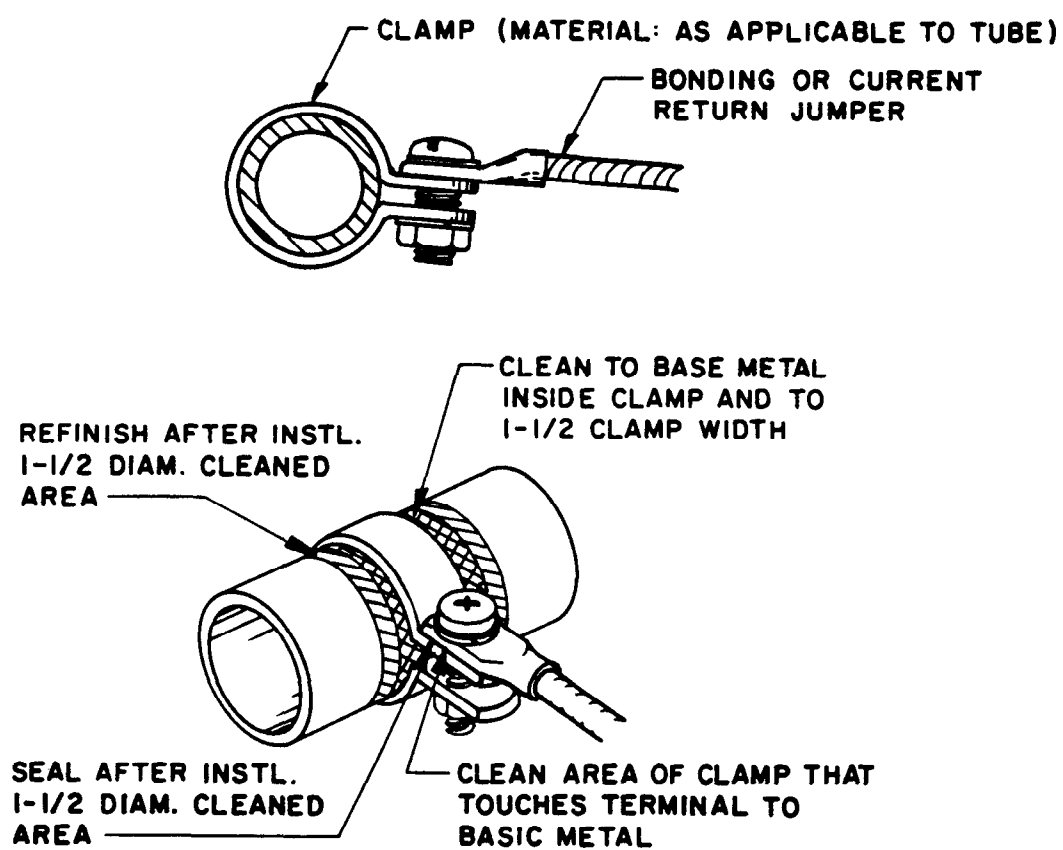


Figure 5-92. Bonding to rigid conduit. (Source: ref 5-6)



EP 1110-3-2
31 Dec 90

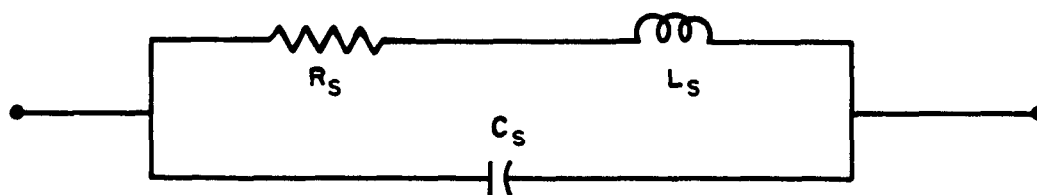


Figure 5-93. Equivalent circuit for bonding strap. (Source: ref 5-6)

EP 1110-3-2
31 Dec 90

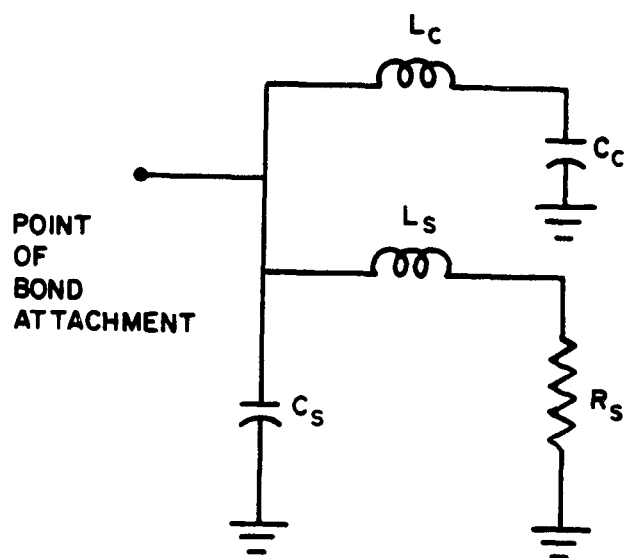


Figure 5-94. True equivalent circuit of a bonded system. (Source: ref 5-6)

EP 1110-3-2
31 Dec 90

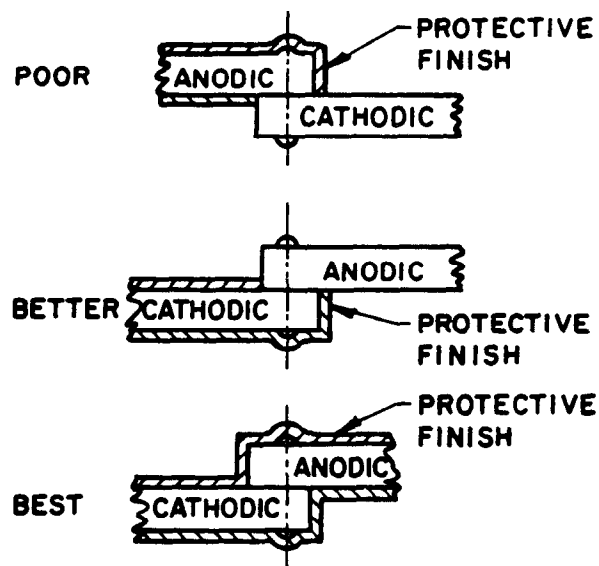


Figure 5-95. Techniques for protecting bonds between dissimilar metals.
(Source: ref 5-6)

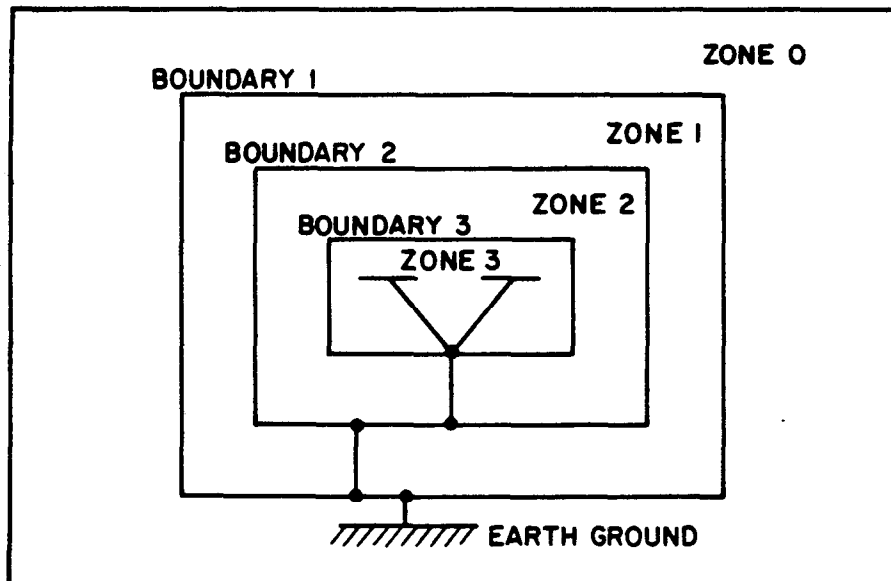


Figure 5-96. Zonal grounding.

EP 1110-3-2
31 Dec 90

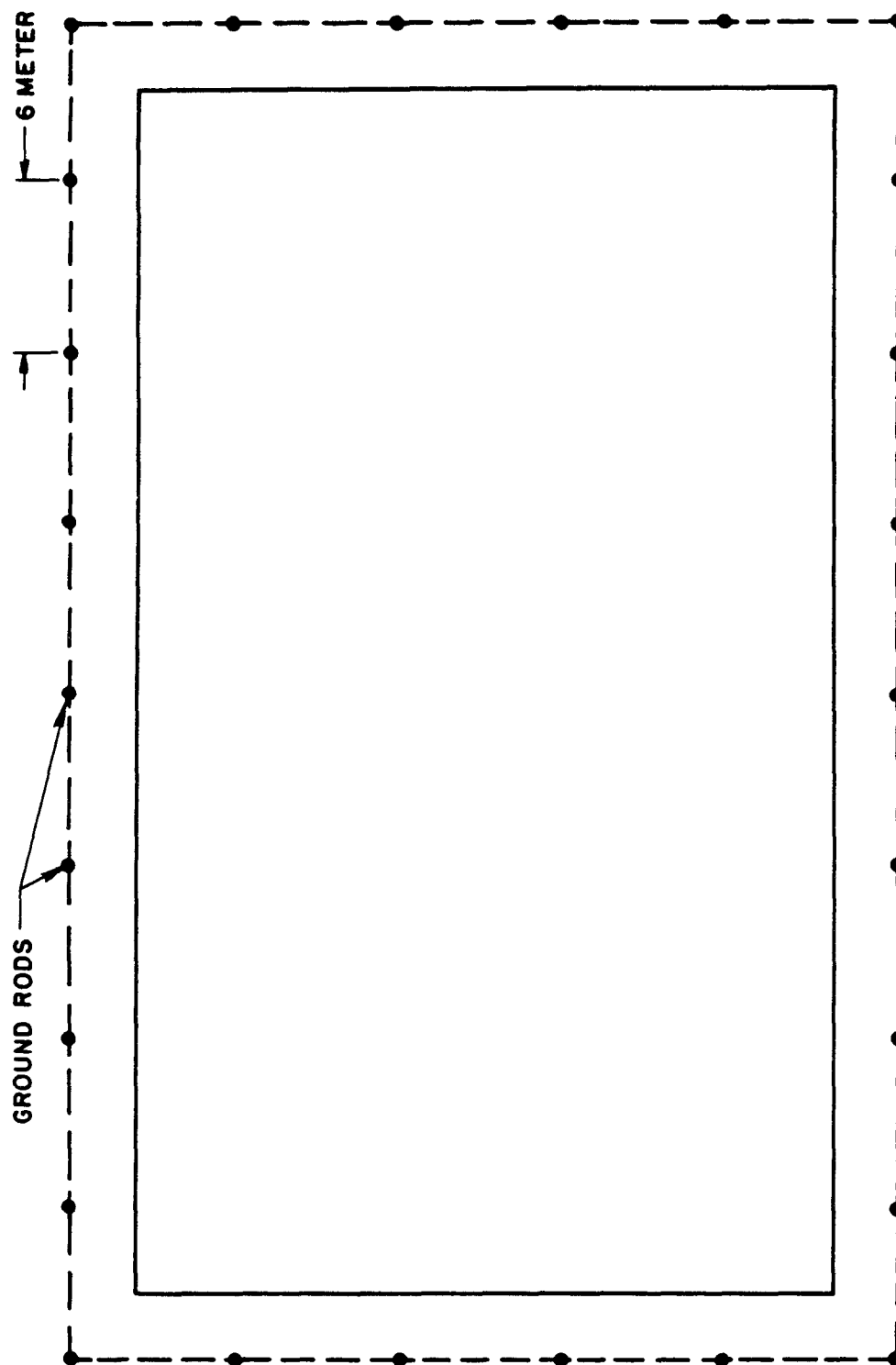


Figure 5-97. Minimum earth electrode system configuration for rectangular-shaped facility. (Source: ref 5-6)

EP 1110-3-2
31 Dec 90

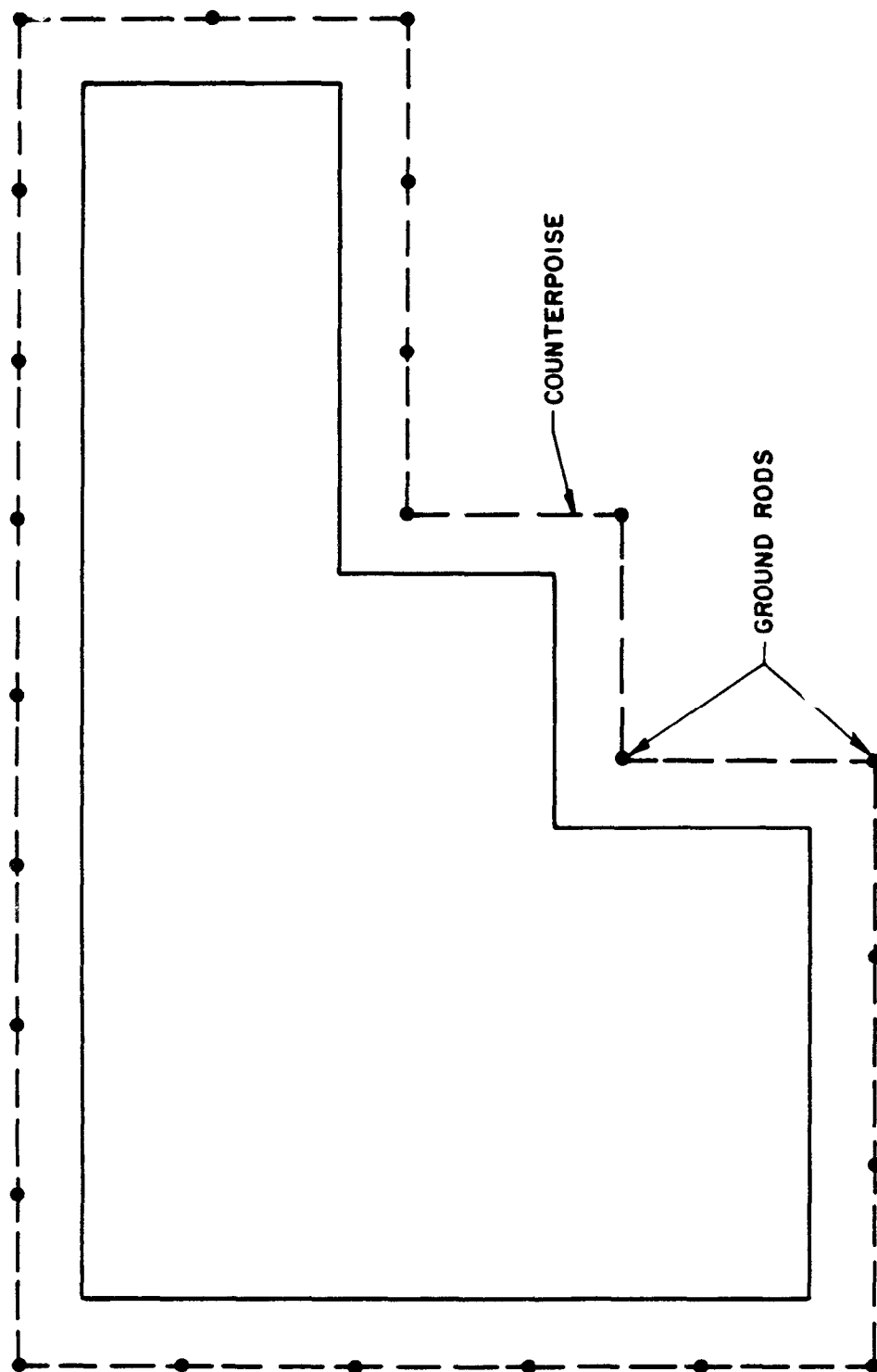


Figure 5-98. Electrode configuration for irregular-shaped facility.
(Source: ref 5-6)

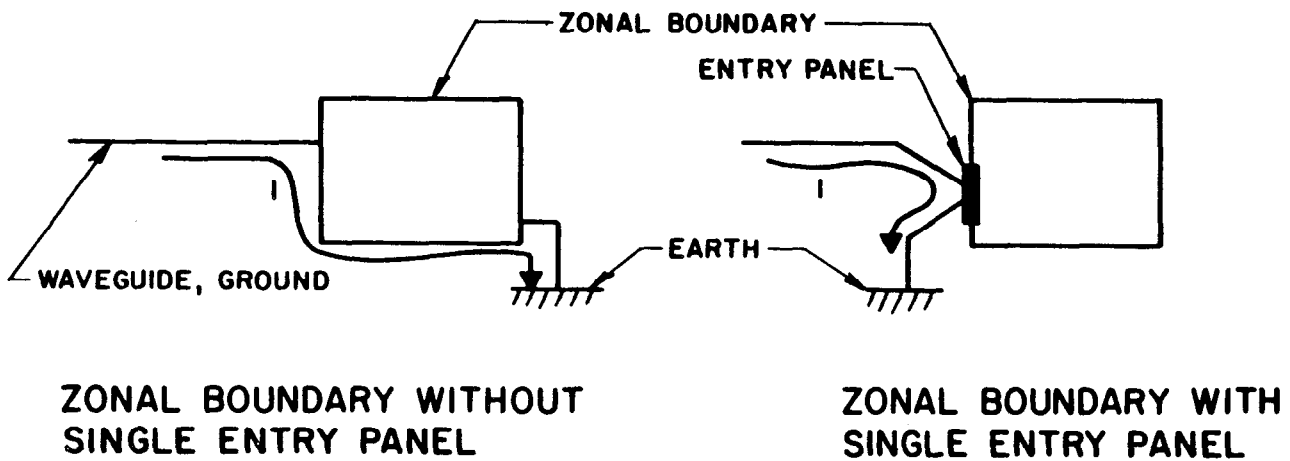


Figure 5-99. Current path on zonal boundaries.

EP 1110-3-2
31 Dec 90

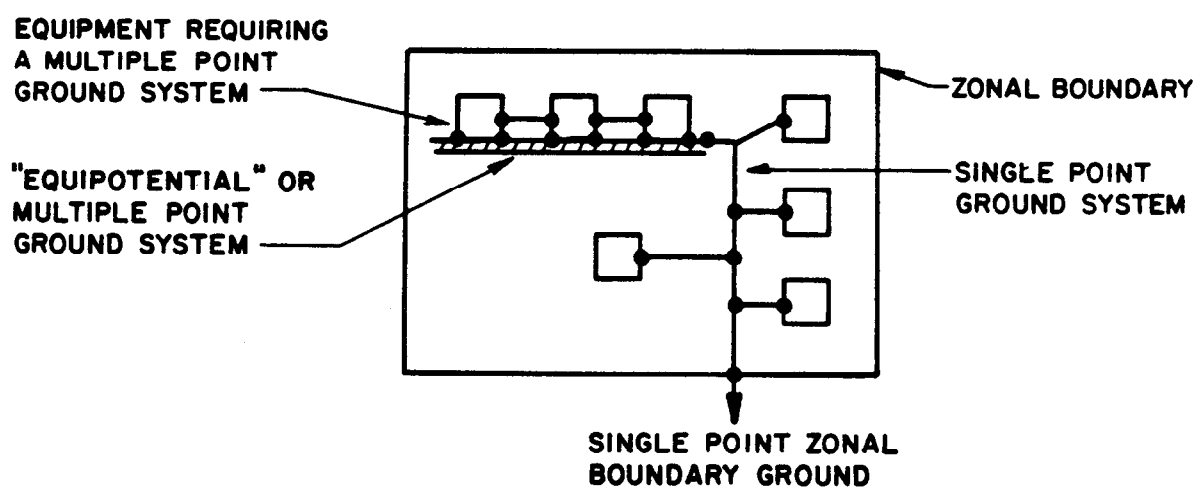


Figure 5-100. Typical hybrid ground configuration.

EP 1110-3-2
31 Dec 90

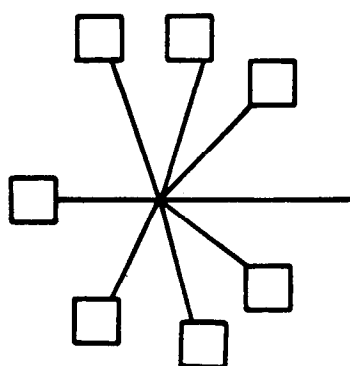
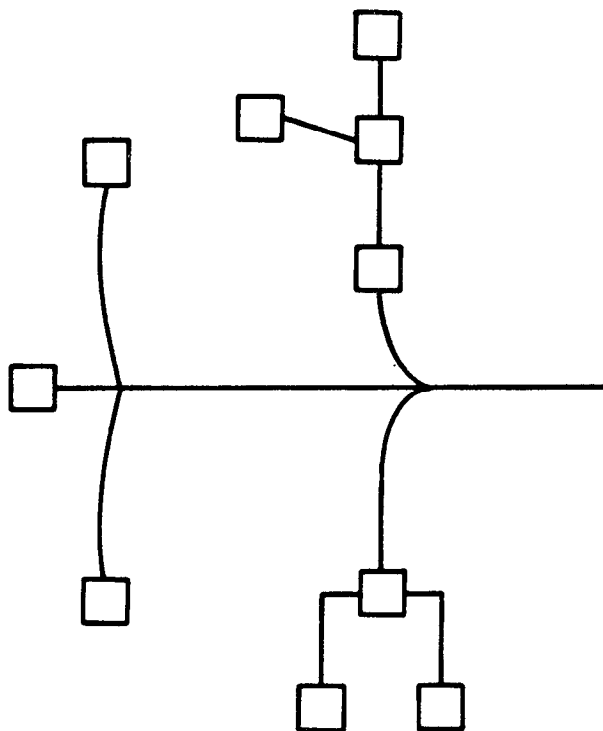


Figure 5-101. Typical ground configurations for HEMP protection.

CHAPTER 6

EMP AND TEMPEST TESTING REQUIREMENTS

6-1. Outline. This chapter is organized as follows:

6-1. Outline

6-2. Introduction

- a. *Why testing is needed*
- b. *TEMPEST measures*
- c. *Quality assurance (QA) testing*
- d. *Acceptance testing*
- e. *Hardness assessment and validation testing*
- f. *Life-cycle testing*

6-3. *Testing requirements vs facility mission*

6-4. *Susceptibility testing*

- a. *Purpose*
- b. *Data analysis susceptibility testing*
 - (1) *Data research*
 - (2) *Analytical modeling*
- c. *Susceptibility testing process*
 - (1) *Importance of early testing*
 - (2) *Laboratory testing*
 - (3) *Cable tests*
 - (4) *Current injection sources*
 - (5) *Scale modeling*

6-5. *Quality assurance testing*

- a. *Purpose*
- b. *Visual inspection and submittal review*
 - (1) *Inspection principles*
 - (2) *Submarine analogy*
 - (3) *Inspection process*
- c. *QA testing methods*
 - (1) *"Sniffer" testing*
 - (2) *Dye penetrant test*
 - (3) *Limited RFI attenuation testing*
 - (4) *Independence of test organization*

6-6. *Acceptance testing*

- a. *Purpose*
- b. *Types of tests*
- c. *Optional tests*
 - (1) *Sources of EM illumination*
 - (2) *Direct injection technique*
 - (3) *When cable testing is required*
 - (4) *Checks of completed facility*

6-7. *Hardness assessment and validation testing (HAVT)*

- a. *Purpose*
- b. *HAVT procedure*

EP 1110-3-2

31 Dec 90

- (1) *Ideal procedure*
- (2) *Testing the building*
- (3) *Radiating EMP simulators*
- (4) *Limitations of simulators*
- (5) *Data and communication lines*
- (6) *Time and expense of tests*
- 6-8. *Life-cycle testing*
 - a. *Purpose*
 - b. *Test methods*
 - (1) *Repeat of acceptance tests*
 - (2) *Performance degradation*
 - (3) *Buried facilities*
- 6-9. *Test methodology*
 - a. *Summary of test approaches*
 - b. *HEMP field simulation*
 - c. *Scale-model testing*
 - d. *Direct injection testing*
 - e. *Shielding effectiveness testing*
 - f. *Laboratory testing*
- 6-10. *Free-field illuminators*
 - a. *Simulated HEMP properties*
 - (1) *Subthreat amplitude testing*
 - (2) *Drawbacks of subthreat amplitude testing*
 - b. *Waveshapes*
 - (1) *Representative waveforms*
 - (2) *Nonrepresentative pulse testing*
 - (3) *Continuous wave (CW) testing*
 - (4) *Drawbacks of CW testing*
 - c. *Spatial coverage*
 - d. *Large-volume EMP simulators*
 - (1) *Free-field simulators*
 - (2) *Bounded-wave simulators*
 - (3) *Pulsed radiated simulators*
 - (4) *Continuous wave (CW) excitation*
 - e. *Scale model testing*
 - (1) *Purpose*
 - (2) *When used*
 - (3) *Limitations of scaling*
 - (4) *Frequency domain of scaled tests*
 - (5) *Effect of scaling on parameters*
- 6-11. *Current injection testing*
 - a. *Purpose*
 - (1) *Transfer functions*
 - (2) *Thresholds and uncertainties*
 - (3) *Effect of several terminals*
 - b. *Direct injection*
 - c. *Inductive injection*
 - (1) *Current transformer*
 - (2) *Advantages of inductive injection*

- (3) *Other methods*
- d. *Methods of current injection testing*
 - (1) *Penetrating conductor drive test*
 - (2) *Gasketed access panels*
 - (3) *Seam sniffer test*
 - (4) *EMP cable shield assembly tests*
 - (5) *Nonconducting data links*
 - (6) *EMP and TEMPEST filter tests*
 - (7) *Conducted transient HEMP environment test*
 - (8) *Terminal protection device (TPD) tests*
- 6-12. *Shielding effectiveness testing*
 - a. *Overview*
 - (1) *Three types of SE tests*
 - (2) *Choice of measurement method*
 - (3) *Overall enclosure SE*
 - b. *Procedure and description*
 - (1) *Low-impedance (magnetic) field SE*
 - (2) *High-impedance (electric) field SE*
 - (3) *Plane wave SE*
 - c. *SE testing summary*
- 6-13. *Bonding impedance measurements*
 - a. *Purpose*
 - b. *Available techniques*
 - c. *When performed*
 - d. *Q-factor comparison*
 - e. *Balanced bridge measurements*
 - f. *Insertion loss*
 - (1) *Principle of insertion loss*
 - (2) *Advantage of method*
- 6-14. *Cited references*
- 6-15. *Uncited references*

6-2. Introduction. From concept definition to design, construction, and the life-cycle phases of HEMP-hardened and TEMPEST-protected facilities, certain testing is required. HEMP hardening, TEMPEST protection, or both may be required for the facility.

a. Why testing is needed. First, testing is needed to identify equipment susceptibilities and to establish hardness requirements, then to prove the concept and model the facility to HEMP. From this testing, the HEMP hardening requirements are developed, the analysis is tested, and shield system modeled and proven. This first phase of testing is called "susceptibility testing."

b. TEMPEST measures. The TEMPEST preventive measures discussed in chapter 8 will determine the shielding requirements.

c. Quality assurance (QA) testing. The second phase of testing begins during construction and is called "quality assurance (QA)" testing. QA testing includes submittal review, material inspection, fabrication and

EP 1110-3-2

31 Dec 90

installation inspection, and onsite testing. QA testing ensures that the specifications for HEMP hardness and TEMPEST protection are fully met.

d. Acceptance testing. The third phase of testing is called "acceptance testing." Acceptance testing is composed of MIL-SPEC-220A and MIL-STD-285 testing, which ensure that the completed facility meets the HEMP hardness and TEMPEST protection requirements. Acceptance testing marks the point at which the user accepts the facility from the construction agency as meeting the required specifications.

e. Hardness assessment and validation testing. The fourth phase of testing begins at or near construction completion and is called "hardness assessment and validation testing (HAVT)" for HEMP and certification tests and procedures for TEMPEST. HAVT is a program that seeks to prove that the method of hardening devised in the concept definition phase has attained the level of hardness required. It consists of various test methods that simulate a HEMP event in conjunction with mathematical analysis. The TEMPEST certification testing requirements and procedures are classified, and the user should refer to the NSA documents for this information.

f. Life-cycle testing. The final phase of testing, life-cycle testing, begins after construction ends and continues throughout the life of the facility. Testing is a combination of a regular maintenance and inspection program and periodic testing of the HEMP and TEMPEST systems to ensure that they retain the original protection requirements throughout the facility life-cycle. This testing includes regular low-level testing of the HEMP hardening components and occasional major testing efforts similar to an HAVT program and TEMPEST shield effectiveness tests to verify that shielding levels are maintained.

6-3. Testing requirements versus facility mission. HEMP and TEMPEST testing requirements vary with the scale and mission of the facility. In general, if the facility is very large in scale and/or very critical in mission, HAVT and susceptibility testing programs are required. If the facility's mission is minor in scale and not extremely critical in terms of mission, HVAT, susceptibility and shield effectiveness testing programs may not be necessary. For small facilities or those for which the mission is not extremely critical, QA, acceptance, and some limited life-cycle testing are required as described in this chapter. For very critical mission sites or very large-scale HEMP systems, complete susceptibility, HAVT, and shield effectiveness testing programs are required along with QA, acceptance, and indepth life-cycle test programs. Table 6-1 summarizes test applicability.

6-4. Susceptibility testing.

a. Purpose. There are three essential reasons to conduct susceptibility testing, which are to establish: the threat in terms of EMP coupling to the facility, the level of equipment sensitivity to the derived threat in terms of damage and upset from ambient to worst case threat, and the required

EP 1110-3-2
31 Dec 90

protection level in terms of decibels required to meet mission requirements, and then to model the protection scheme versus the threat as a check prior to final design. Susceptibility is the testing responsibility of the Government, though it is often done by contract.

b. Data and analysis susceptibility testing. These tests involve analytical modeling, and actual testing to check data and analysis accuracy.

(1) Data research. Data research consists of a documentation search through lessons learned in past similar projects, susceptibility figures for equipment impacted by EMP that will be used in the project, and other useful data such as EMP protection methods in the R&D stage that may be considered for the project.

(2) Analytical modeling. Analytical modeling consists of mathematical calculations, computer codes, and analysis, which usually forms the bulk of the threat resolution. Specialists in EMP phenomenology perform this analysis and generate testing requirements to validate their results.

c. Susceptibility testing process.

(1) Importance of early testing. Susceptibility testing helps the designer evaluate and select the best design option before freezing the design and beginning the construction or fabrication phase. Component and equipment testing provide the information needed to derive protection requirements and prepare specifications for vendor-supplied or specially fabricated protective elements such as EMP/EMI filters, surge arresters, and combinations of these devices. At the facility level, laboratory tests usually are done on mockups, scale models, and fabricated sections of larger structures. For electronic/electrical hardware, the testing may involve components, subassemblies, assemblies, equipments, subsystems, and even whole systems depending on the test requirements, size, availability, etc.

(2) Laboratory testing. Several test techniques are readily adapted to laboratory testing. For measuring the shielding effectiveness of small (equipment enclosures) to room-size enclosures, the large loop test, Helmholtz coil test, parallel plate transmission line, or even radiated sources (continuous wave [CW] or pulse) may be used. Door and seam leakage can be measured using the small loop-to-loop or antenna-to-antenna tests from MIL-STD 285 (ref 6-1) or IEEE 299 (ref 6-2) from low frequencies (a few kilohertz) through the microwave range (gigahertz). The "seam sniffer" can also be used as a qualitative test for door and seam leakage.

(3) Cable tests. Cable (for braided shields, foil shields, and conduits) and connector effectiveness can be measured in the laboratory using the "quadraxial" or "triaxial" test technique. These techniques measure the transfer impedance of the cable assembly which is useful in determining terminal protection requirements. The transfer impedance is directly related to the SE analytically. To measure cable EM radiation, the coaxial test method

EP 1110-3-2

31 Dec 90

also can be used in the laboratory in conjunction with the "seam sniffer" or some other receiver.

(4) Current injection sources. Current injection sources also are useful in laboratory testing. Both direct injection and cable-driving techniques are used to determine the susceptibility of equipment interface circuits to EM-induced transients. The type of source (that is, the waveform) to be used should be determined based on the coupling analysis. These current injection sources also can be used to evaluate the SE of terminal protection devices (TPDs) such as surge arresters and filters. Care must be taken when testing TPDs to prevent their partial degradation (shortened lifetime).

(5) Scale modeling. Scale modeling is another useful way to validate coupling analyses and determine system and/or facility responses to an incident EM field.

6-5. Quality assurance testing.

a. Purpose. QA testing ensures that the intent of the design drawings and specifications are met during construction of the facility. QA for EMP and TEMPEST is an extension of the normal QA procedures in any construction project. QA testing for EMP and TEMPEST validates that the EMP and TEMPEST system is constructed per the design and meets the protection levels required. It is a process of visual inspection of fabrication, construction, and materials, review of EMP and TEMPEST construction submittals, and onsite testing throughout the construction phase.

b. Visual inspection and submittal review. On every project, an inspector will be assigned by the Government for QA purposes. This inspector must become familiar with basic EMP protection methods and must have a source of EMP expertise for the questions that usually arise during construction regarding substitution, construction methods, and engineering changes.

(1) Inspection principles. The basic principles of inspection for high-quality shielding constructions are quite simple and can be learned easily. They consist of a basic knowledge of welding and welding inspection, a working knowledge of HEMP and TEMPEST criteria and how it couples with a facility, and a better than fair measure of common sense.

(2) Submarine analogy. In general, the inspector needs to know only that EMP is an electrical threat which is analogous to water around a submarine: the submarine is the facility and the water is the EMP threat. Conversely, the air in the submarine is the electromagnetic radiation. To keep EMP out and the EM radiation in, the inspector must ensure that all penetrations of the shield (hull) are sealed in some manner. This is done with EMP and TEMPEST filters on conductive lines, EMP and TEMPEST waveguides on utility entrances (gas, water, oil, etc.), fiber optic lines for control and communication lines (or filters), WBC filters for ventilation penetrations, and RFI-tight doors and hatches for personnel entry. It is not

necessary to understand the physics which make these devices work--only that they are in place and RFI-tight at their joint with the shield by proper attachment (weld or gasket). Common sense is far more important than an in-depth knowledge of physics. In the case of submittal review or complicated EMP and TEMPEST problem areas, however, an EMP/TEMPEST expert must be available to the inspector to provide comments and recommendations based on the intent of the design drawings and specifications and his or her own knowledge of EMP and TEMPEST protection methods.

(3) Inspection process. The EMP/TEMPEST expert need not be located onsite and need only spend a limited portion of time for submittal review, construction inspection of critical phases, and EMP/TEMPEST problem resolution. The construction inspector is usually well qualified with the above knowledge to handle day-to-day construction inspection of the EMP/TEMPEST system.

c. QA testing methods. QA testing consists of shielding effectiveness leak detection system (SELDS or "sniffer testing"), or dye penetrant testing, and some MIL-STD-285 type antenna/receiver attenuation testing. All welds should be 100 percent visually inspected.

(1) "Sniffer" testing. SELDS testing is used to test high-quality floor shield seams (100 percent) and also serves as acceptance testing for floors since they are impossible to test once covered by the interior finish. The SELDS technique or similar "sniffer" tests detect defects in shield continuity and are described in detail later in this chapter. These tests are used to test 100 percent of the wall seams, critical penetrations, and roof seams to find and correct repetitive problems early in the construction phase. Two items are of special note. First, these tests should be conducted prior to interior finish, or the finish may have to be disassembled to repair and retest defects. Second, the acceptance testing described in paragraph 6-6 should also be completed as much as possible before the interior/exterior finish is applied.

(2) Dye penetrant test. The dye penetrant test is a simple procedure using white and blue dye (usually) to show weld defects. It should be conducted at random sites or where visual inspection of welds has indicated that a problem may exist or in corners where SELDS testing cannot be performed.

(3) Limited RFI attenuation testing. Limited RFI attenuation testing as described in MIL-STD-285 may be required to test WRC assemblies or door installation onsite if there is reason to believe some problem may exist.

(4) Independence of test organization. Usually an independent test organization is furnished by the contractor for both QA and acceptance testing as set forth in the specifications.

6-6. Acceptance testing.

EP 1110-3-2
31 Dec 90

a. Purpose. The purpose of acceptance testing is to confirm that the constructed facility with all of its penetrations and protective devices in place meets the hardness requirements as stated in the specifications. The MIL-STD-285, MIL-SPEC-220A, and SELDS tests comprise the set of acceptance tests. Based on the uniqueness of the facility or mission, other testing methods may be substituted.

b. Types of tests. The standard EMP and TEMPEST specifications include MIL-SPEC-220A, which describes factory testing for EMP and TEMPEST filters. Also included as a minimum is the MIL-STD-285 test to assess the RFI tightness of a facility as a whole. In brief, the test works by placing an antenna on the in/out side of the facility and a receiver on the other side and measuring the attenuation of the shield to see if it meets the specification. (See MIL-STD-285 for details.) This test evaluates every facet of the facility except for EMP and TEMPEST filters (power/commo) and is used as an acceptance test for the facility as a whole in terms of the EMP and TEMPEST protection system. The test should be performed such that every seam is tested and all penetrations are closely tested. The contractor must correct all deficiencies and then retest the deficient areas. Other tests may be used as necessary for the unique requirements of each facility. This paragraph has described the minimum standard. Paragraph c below describes in detail other testing that may be required. Normally, acceptance testing is done by an independent agency contracted by the contractor as described in the specifications.

c. Optional tests.

(1) Source of EM illumination. For individually shielded elements/subsystems, the SE can be determined using Helmholtz coil illuminators, parallel plate transmission lines, or radiated sources. These sources of EM illumination can be quite small in terms of the working volume since only "box" size units will be evaluated. The "box" can be exposed to any polarization or angle of arrival by rotating the unit being tested.

(2) Direct injection techniques. TPD (filters and surge arresters) SE and subsystem susceptibility at the interfaces (cable connectors) can be measured by direct current injection techniques. As in the case of laboratory testing, the level of threat derived through analysis can be used to assess shield performance. This threat level should be increased in amplitude by the specified design margin (DM) to ensure the DM has been achieved. These tests should be done on prototype equipment at 100 percent of interface circuits.

(3) When cable testing is required. Cable tests are required only if they are delivered as part of the subsystem and are exposed to the HEMP threat. If the facility uses envelope shielding and interior fields are reduced to a "safe" level, no cable testing is required. If cable testing is needed for cables that exit the facility, the same approaches as described in paragraph 6-3 for susceptibility testing can be used.

(4) Checks of completed facility. Facility checks on completed facility construction should include preliminary (before installation of equipment) SE tests on the facility shield and on secondary shields inside the facility such as that for electrical conduit and interior shielded enclosures (including the entry vault). In addition, cable grouping/configuration control should be inspected and nonelectrical and electrical (power) penetration treatments should be inspected and subjected to penetration tests. EMI doors, vents, and other apertures also should be inspected and tested. Penetration control for facility-installed (in the entry vault) TPDs and nonconductive data lines (fiber optic links) should be tested. These tests must be performed on all penetrations.

6-7. Hardness assessment and validation testing.

a. Purpose. HAVT is a post-construction test program conducted by the Government to evaluate the actual HEMP protection provided by design and construction. It ensures that the design requirements have been met and that the full constructed facility meets predicted hardness levels. It also validates predicted coupling paths and equipment susceptibility. HAVT is a program that generally is used only for very large and/or vital mission facilities. This testing is done at the end of construction/fabrication and equipment installation, but before turning over the facility to the user for the operation and maintenance (O&M) phase. The tests should show that the facility as built performs its design function.

b. HAVT procedure.

(1) Ideal procedure. Ideally, it is desirable to illuminate the entire facility, including external cables (power and communication), with an EMP simulator that can produce the threat waveform at threat amplitude. However, state-of-the-art EMP simulators do not permit such a test. Threat-level EMP simulators can produce only the threat criteria amplitude over compact structures or systems (for example, vehicles, small buildings, and missiles). In many cases, the facility under test must be in the near field of a radiating simulator, which means plane wave field propagation is not achieved.

(2) Testing the building. To test the building, both bounded-wave and radiating-type EMP simulators can be used. Bounded wave simulators are parallel plate transmission lines. These lines use an upper conducting surface (wires) over the building and a ground plane on the Earth's surface to which the building is bonded. For good field uniformity, the building should be less than two-thirds the vertical height of the simulator. The illuminator for this system is constructed onsite. To test various angles of arrival, the illuminator must be oriented in several ways.

(3) Radiating EMP simulators. Radiating EMP simulators are large dipole antennas over ground. They can produce threat-level fields at close ranges (50 meters on center line for the transportable EMP simulator [TEMPS]).

EP 1110-5-7
31 Dec 90

However, this range is in the near field and, therefore, except for small facilities, field uniformity or peak field time of arrival is sacrificed.

(4) Limitations of simulators. Neither the bounded-wave nor radiating threat-level simulator can fully illuminate the external penetrants (such as cables and pipes) to certify overall performance. Illumination for larger areas is possible with either pulse- or CW-type radiating sources, but field amplitude is sacrificed. For testing SE, low-level illumination is adequate. The test system, however, must have a dynamic range greater than the SE level. The drawback with low-level testing is that nonlinear TPD effectiveness is not determined. Also, since these TPDs are nonlinear, analytical extrapolation is not adequate. Ferromagnetic material shields also have nonlinear properties (that is, reduced magnetic permeability at high field levels) which would not be assessed at low-level testing. The SE for these shields can be estimated analytically.

(5) Data and communication lines. Penetrants such as data and communication lines are best evaluated using current injection simulators in a cable injection mode. With this method, the simulator signal is induced on the cable shield or pipe and the system response is measured. Current injection simulators are available⁴ that can be synchronized to the radiating or bounded-wave simulators or as multiple injection sources to achieve more realism in a certification test. These current injection sources can evaluate TPD performance, including the DMS in most cases.

(6) Time and expense of tests. The test approaches discussed are all very expensive and take a long time to perform. However, if facility certification (with high confidence) is required, they are necessary. These tests can be done while the facility is operating (power "on") and while it is quiescent (power "off") to evaluate temporary upset as well as damage.

6-8. Life-cycle testing.

a. Purpose. The purpose of life-cycle testing is to provide tangible evidence that the EMP shielding system and protective devices have not degraded unacceptable over time. Life-cycle testing needs should be established at the design stage and kept as simple as possible. Intermittent low-level testing of critical penetrations such as RFI doors should be a part of scheduled maintenance procedures. Over longer periods of 5 years or more (depending on mission criticality), a major test program should evaluate the shield as a whole, focusing on known weak points. Paragraph b below describes test methods that may be employed.

b. Test methods.

⁴At the Harry Diamond Laboratories/Woodbridge, VA, facility.

(1) Repeat of acceptance tests. In maintaining a facility, the main concerns are the facility shield, cable shields, and penetration control (TPDs and entry vault area). These elements could be retested using the same approaches as described for the certification tests (that is, large area threat-level simulators and current injection devices). This testing would recertify the facility and would be an absolute quantitative measure of facility performance. However, these methods do not permit testing by onsite personnel; the simulators must be brought to the site and erected, and as a result, the cost would be excessive.

(2) Performance degradation. For the recurring periodic surveillance, it is not necessary to measure the absolute performance. What is of primary concern is the possible performance degradation since the facility was certified operational. Thus, these hardness surveillance (HS) tests can be done at a few frequencies and compared with baseline data taken at the time of certification. SE tests on the facility shield can be performed using low-level continuous wave (CW) illuminators. Cable shield and TPDs can be tested using current injection sources. Doors, apertures, and seams can be assessed using the seam sniffer or small-loop tests. This discussion assumes there is access to the facility shield and penetrants as with above-ground facilities.

(3) Buried facilities. In buried facilities, access to the shield and cables is not possible--especially when an outside envelope shield is used. Therefore, the HS approach must be modified. SE of the facility shield could still be tested by CW measurements but the power level or receiver sensitivity (test system dynamic range) may have to be increased. Seam sniffer tests could not be used, but the Helmholtz coil approach could if the exciting Helmholtz coil is installed during construction as a permanent fixture on the structure with the drive terminals accessible. Localized sources also could be used if they are installed at the time of construction. Cable tests may require sense or drive wires inside the cable shield to measure shield SE, with external CW illumination to drive the cables or magnetic loop sensors to sense the leakage during source wire driving. These built-in test approaches will depend on the facility design and therefore no specific approach can be recommended; care must be taken to ensure that the TEMPEST requirements are not compromised. The options must be considered at the time of facility design and the best method selected on a case-by-case basis.

6-9. Test methodology.

a. Summary of test approaches. The various HEMP tests fall into five general classes as summarized below.

b. HEMP field simulation. These tests require large simulators that can illuminate the entire system or subsystem with the required EM fields. HEMP simulation is used to determine coupling paths and levels and to validate hardness.

EP 1110-3-2

31 Dec 90

c. Scale-model testing. During the design phase, testing a scale model of the facility is a cost-effective way of determining potential HEMP problems. For these tests, a scale model of the system must be constructed. The model is illuminated with scaled EM fields (including rise time, fall time, amplitude, and other parameters) and the model response is measured. The response of the real system is then predicted analytically. Scale model testing is used to determine coupling to enclosures, to help conduct full-scale testing, and to assess the effects of changes in design.

d. Direct injection testing. Current injection testing consists of inducing or direct-driving currents on conductors. It is used to determine transfer functions and to measure upset and damage thresholds along with their uncertainties.

e. Shielding effectiveness testing. SE testing as discussed here refers to methods of testing a shield using CW without using HEMP field simulators. Relatively small, low-cost instruments and antennas can be used to probe seams, openings, and gaskets. These methods often are used to measure shield quality during fabrication/construction and degradation over time.

f. Laboratory testing. It is often desirable to perform laboratory tests to evaluate specific designs prior to facility construction.

6-10. Free-field illuminators.

a. Simulated HEMP properties. Several HEMP tests can be classed by the properties of the simulated HEMP. The pulse amplitude can be threat or sub-threat. The waveshape can be a representative pulse (similar to threat criteria waveform), nonrepresentative pulse, or CW. For pulse-type simulators, the condition of wave planarity (close approximation to a plane wave) must be met. This condition is achieved by the simulator design in bounded-wave simulators, but requires the test object to be in the antenna far field for radiating pulse simulators. Pulsed fields are measured in the time domain. In the case of CW, measurements are taken in the frequency domain. Therefore, in addition to the requirement of being in the antenna far field to achieve wave planarity, there is a requirement to measure both the amplitude and phase at each frequency of the coupled or free-field signal so that the time domain response can be reconstructed. The repetition rate of pulse-type simulators can be single-shot or repetitive pulse. Any of these methods can be used with any of the testing tools to be described later. Some of these methods, though, may always be used with specific testing tools. Each method has advantages and drawbacks as discussed in the rest of this chapter.

(1) Subthreat amplitude testing. Most tests can be done at subthreat or threat amplitude. Subthreat amplitude testing is useful because currents and voltages in a linear system are roughly proportional to the EM field that induces them. Coupling tests can be done at a factor below the expected threat amplitude and the resulting currents and voltages can be scaled up by that same factor for linear systems. The equipment used in subthreat

EP 1110-3-2
31 Dec 90

amplitude tests (either CW or pulse) is less expensive and more readily available than that needed for threat amplitude testing. Subthreat amplitude testing can be done repetitively because the capacitive pulse generator needs less time to charge for lower amplitude pulses. Subthreat amplitude testing can also be done while the system operates without damaging the equipment.

(2) Drawbacks of subthreat amplitude testing. Subthreat amplitude testing has several drawbacks. These translate into advantages for threat amplitude testing. First, the induced currents and voltages are only roughly proportional to the EM field that induces them. No exact proportionality exists because, in nonlinear systems, the load impedance can vary as a function of the voltage across it. This property is one of the main operating principles of transient suppressors--an exponential decrease in resistance when the voltage rises above the firing voltage. Subthreat amplitude testing generally will not reach this voltage level and thus, cannot test transient suppressor response. For this reason, threat amplitude testing has a higher confidence level, especially during the hardness validation. If a system survives several tests using amplitude pulses and shows no damage, it can be considered hard to the test environment. The test environment must be analytically related to the actual threat to obtain final certification of system hardness. Subthreat amplitude testing, in contrast, is often used to determine coupling at the terminals of equipment and components and to validate analyses. The scaled-up data are then compared with threshold values to determine protection requirements. One final advantage of threat amplitude testing is that measurement equipment can quickly detect any significant coupling. The same coupling, scaled down by a factor of 10 or 100, could be undetectable or obscured by noise.

b. Waveshapes

(1) Representative waveforms. The most clearcut testing is by representative waveforms (similar in waveshape to threat criteria waveforms). The amount of analysis required is less and confidence is higher than for nonrepresentative pulse waveforms or continuous wave tests. The simulators currently available produce the double exponential HEMP waveform. Simulator upgrades are in progress to produce the MIL-STD-2169 HEMP wave forms.

(2) Nonrepresentative pulse testing. Nonrepresentative pulse testing is mainly used because threat waveforms are hard to duplicate. Although a nonrepresentative pulse has a waveshape different from the threat criteria waveform, it must contain all spectral components of the threat criteria waveform. Cheaper, more readily available equipment can produce a pulse similar in amplitude and duration, but not in shape. The drawback is that thorough analysis is required to relate the response of a nonrepresentative pulse to the threat criteria pulse response.

(3) Continuous wave (CW) testing. CW testing uses many discrete frequency waves or a swept frequency source within the illuminator bandwidth to excite the system and the response is measured at each frequency. Fourier

EP 1110-3-2
31 Dec 90

transform methods can be used to find the time domain response for any arbitrary waveshape using the measured data base. To determine the time domain response using Fourier transform methods, both amplitude and phase data are required at each frequency. CW testing allows the use of sensitive measurement equipment through synchronous detection and/or signal integration techniques, which, in turn, allows testing at very low amplitudes. Also, continuous wave illumination allows nonstop probing of terminals to measure coupling. The instruments are more easily adjusted so the quality of data is improved, resulting in shorter test times. CW testing directly supports an analysis method that models the system as a network of resistances, inductances, and capacitances, with the analysis performed in the frequency domain. These system elements can be determined from CW testing. Nonlinear transient suppressors can then be modeled and added to the system model and the system response determined as a function of frequency. The time domain response can be derived analytically and related to the threat.

(4) Drawbacks of CW testing. CW testing has several drawbacks not found with pulse testing. It can be a long process, unless computerized, because the response must be measured for many frequencies. Also, the phase of the measured response data must be recorded as well as the amplitude. The phase information is required to determine the time domain or transient response of the system.

c. Spatial coverage. Perhaps the most limiting factor of simulated HEMP testing is the spatial coverage. It is not possible with present EMP simulators to illuminate large areas (for example, several acres) to threat-level HEMP fields. The field strength declines as $1/R$ (in the far field), where R is the distance from the source. For radiating simulators (pulse or CW), far-field testing is required to obtain the necessary planarity of the EM wave. Thus, different parts of a large system will see different field levels. Also, the radiation-ground interaction causes polarization changes and other contaminating effects. It is not possible to illuminate miles of power or communications lines, which would be necessary to evaluate HEMP threat transients at a penetration using bounded-wave or radiating types of EMP simulators. Penetrations due to long lines can be evaluated using current injection methods in which the HEMP-induced transient injected is determined through analysis or through coupling tests with the EMP free-field simulators (see para 6-11). Details of spatial coverage will be given as each simulator is discussed.

d. Large-volume EMP simulators. Full-scale illumination is usually done at the system or subsystem level using EMP free-field simulators. It is used to determine coupling at all levels of a system for analysis validation. It is also used after construction is complete to demonstrate the hardness of a system as part of the validation process. Since nonlinear transient suppressors are widely used for hardening, threat amplitude testing is usually needed to validate hardness at a high level of confidence. High-level testing of long lines is done by pulsed current injection at the facility entry panel. Field simulators can produce either horizontally or vertically polarized

waves. If the coupling is known for both polarizations, it can be found for any polarization. It is likely, though not certain, that a system which is hard for both polarizations is hard for any polarization. Other polarizations can be obtained by using different simulators or by using different simulator-to-system orientations. To evaluate the coupling for various angles of arrival (both vertical and horizontal), the relative positions of the simulator and the facility under test must be changed. Several angles of arrival should be used to obtain the maximum coupling to the facility and to assess all possible ports of entry (all sides of the facility as a minimum).

(1) Free-field simulators. There are three basic kinds of free-field simulators for illuminating full-scale systems (at least for relatively compact systems). Bounded wave simulators are so called because the waves are mostly confined to a definite volume. This efficient use of energy makes these simulators well suited for threat amplitude testing. Pulsed radiated simulators also can be used for threat amplitude testing. They can handle larger systems, but the pulse amplitude decreases as $1/R$ (in the far field), where R is the distance from the simulator. Close to the simulator, the fields do not approximate plane waves well, so there is always a tradeoff between amplitude and good plane wave approximation. CW radiators produce very low amplitude, discrete frequency waves over a wide frequency range. The field amplitude declines as $1/R$ (in the far field) as with pulsed radiated simulators with which the plane wave approximation is realized. Different radiators are used for different frequency ranges. These simulators are specially made to produce CWs.

(2) Bounded-wave simulators. Figure 6-1 shows two bounded wave simulators that produce vertically (top) and horizontally (bottom) polarized waves. The pulses start at one end, travel the length of the simulator, and are absorbed. The wire spacing must be small compared with the highest frequency to be generated. Some bounded wave simulators are made of solid sheet metal. Each simulator has a certain working volume in which a relatively uniform field can be produced. This volume ranges from 10,000 to 500,000 square meters for existing simulators. The field is not completely confined to this working volume, is not a perfect plane wave, and does not have exactly the same amplitude and polarization everywhere within the working volume. Also, testing a large system causes distortion that would not occur in a real HEMP environment. Despite these problems, the bounded wave simulators model HEMP better than any of the other methods to be discussed. Existing bounded wave simulators include ALECS, ARES, and TRESTLE at Kirtland AFB, TEFS at WSMR, and TEFS at NSWC/WOL. Table 6-2 summarizes the properties of these simulators.

(3) Pulsed radiated simulators. Figure 6-2 shows two common pulsed radiated wave simulators. The 20-meter-high inverted cone-shaped monopole produces vertically polarized waves. An example of this type of equipment is the Vertical Electro-Magnetic Simulator (VEMPS). A small horizontal component may be present, depending on the ground conductivity, if no ground plane is provided. In some simulators (such as EMPRESS I), an antenna is attached to

EP 1110-3-7
31 Dec 90

the top of the cone and extended horizontally some distance. It is terminated with resistive elements to the ground. The cone produces the high frequencies (greater than 1 megahertz) needed for short rise time and the horizontally extended antenna produces the lower frequencies. The 300-meter-long dipole produces mostly horizontally polarized waves. One such simulator is the Army EMP Simulator Operation (AESOP). A vertically polarized component of the wave is introduced off the antenna center line. Field maps are available for all the simulators listed in table 6-3. Like the inverted, cone-shaped monopole, the conic section produces high frequencies and the horizontal antennas produce the lower frequencies. Both simulators produce a radiated pulse whose amplitude varies roughly as $(\sin \theta)/R$, where θ is the angle away from the conic monopole or dipole and R is the distance from it. Ground effects make amplitudes deviate from this formula and also distort the waveshapes and polarization. Close to the simulator, the radiated pulse is not a plane wave. Therefore, a system under test must be placed at some distance to approximate a plane wave. Existing pulsed radiated wave simulators include the VPD and the HPD at Kirtland AFB, NM; the Harry Diamond Laboratories (HDL) biconic, AESOP, and VEMPS, at HDL, Woodbridge, VA; EMPRESS at NSWC, Solomons, MD; EMPSAC and NAVES at NSWC/NATC, Patuxent, MD; and TEMPS, a transportable simulator. (See table 6-3.)

(4) Continuous wave (CW) excitation. CW testing is used for both qualitative and quantitative measurement of coupling and SE. CW testing can measure only linear system parameters. Figure 6-3 shows a typical CW test configuration for measuring the coupling to a missile. The test system includes: signal source, amplifier, antenna, sensor, and detector. Note that a reference signal is needed to provide phase data. CW testing is usually done at several frequencies or using a swept signal across the HEMP spectrum.

e. Scale model testing.

(1) Purpose. Although limited, this is a useful coupling and analytical validation tool. It is mainly used to empirically estimate fields, currents, and voltages outside enclosures. Coupling on exterior cables and antennas can be measured easily. These cable and antenna currents can then be simulated by current injection for the real system to find the system response. Scale model testing can also be used before real system testing to give a rough idea of what results to expect or to aid in the design. It can show the worst-case direction of arrival and can help in placing the sensors and simulator.

(2) When used. Scale model testing can be done during the design phase for a system when other tests would not be possible. It can spot problems in the HEMP hardness design early enough to permit inexpensive modifications. It can also be used to assess various design modifications that could correct the problems. Two other advantages of scale model testing are that it is adaptable to very large systems and is low in cost.

EP 1110-3-2
31 Dec 90

(3) Limitations of scaling. Scaling, however, is suited only for testing external coupling on the system's exterior boundary. Building material also limits the use of scale model testing. For example, if the real system uses an unusual material, such as a special composite, the EM properties (conductivity, permittivity, and permeability) of the material do not scale in a simple way. Also, seam construction may be hard to scale. Scale models thus are most useful for metallic, enclosed systems such as aircraft, missiles, shielded enclosures, and power distribution systems.

(4) Frequency domain of scaled tests. Scale model testing is done only in the frequency domain (pulse or CW testing). If a system is scaled by 1/2, CW frequencies must be doubled. In terms of pulse excitation for a double-exponential waveform, this is the same as cutting the rise time in half (plus adjusting the deviation and fall time).

(5) Effect of scaling on parameters. Table 6-4 shows how various parameters are affected when a system is scaled down by a factor of M. Typically, a scaling factor less than 50 is used. For large systems, it is best to use a larger scaling factor, but this is not always possible. The main drawback to scaling up the frequency is that rise times must be scaled down and rise times less than 10^{-10} seconds are very hard to produce unless one shifts to a different frequency domain. Another problem is that the conductivity of the material used to construct the scale model should be scaled up. Earth is usually modeled with ordinary soil, but with salt added to raise its conductivity. For other materials, such as steel or copper, the conductivity cannot be scaled properly because there is no material with a large enough conductivity. There is a way to partly solve this problem for building walls or shielding, however. The scaling needs for conductivity and thickness can be ignored as long as their product is kept the same. This method at least scales the conductance correctly.

6-11. Current injection testing.

a. Purpose. Current injection testing has two main uses: to determine transfer functions and equipment susceptibility thresholds.

(1) Transfer functions. To find transfer functions, pulses usually are used, but CWs will also work. Given the coupling on cables and other conductors penetrating an enclosure, a transfer function gives the voltage and/or current at the terminals of equipment and components inside the enclosure. Transfer functions will generally be linear unless transient suppressors are present. The complete calculation of a nonlinear transfer function requires measurements at many amplitudes. However, the usual practice is to determine the transfer functions only for the induced threat amplitudes. The exterior coupling to conductors entering enclosures can be found by analysis, scale model testing, or field simulation.

(2) Thresholds and uncertainties. The other use of current injection testing is to measure susceptibility thresholds and threshold uncertainties

EP 1110-3-2
31 Dec 90

for equipment parts and semiconductors. This test can usually be done in the laboratory and pulses are always used. Several identical items are subjected to increasing levels of current or voltage until they fail. More than one item is tested so that the threshold and its uncertainty can both be found. These data can be cataloged and are useful in designing new systems, equipment, and components. They also allow thresholds and uncertainties to be estimated for existing items.

(3) Effect of several terminals. Both uses of current injection testing become more complex when several terminals must be injected. A building with many types of penetrations or an integrated circuit with 10 or 20 terminals presents problems. These tests are especially difficult if all the terminals must be injected at once with a different amplitude pulses, each with a different phase. Current injection can be done directly onto conductors that carry signals or it can be coupled inductively onto these conductors. The best method will depend on local conditions; for example, direct injection tests require that a cable be disconnected.

b. Direct injection. Figure 6-4 shows one way to inject current directly onto the signal-carrying conductors in a cable. The impedance matrix simulates the normal impedances between the conductors and between the conductors and the ground. For shielded cables, the shield can be used as the return path. In some cases, wires or groups of wires may need individual injection to obtain good simulation. In this type of testing, the cable to be tested must be disconnected as mentioned in paragraph a (3) above. This setup may not be acceptable if it produces significant changes in the operation of any connected equipment. One way to avoid this situation is to leave the cable connected and inject current onto the wires through capacitors. The capacitors let the circuite normally. However, with this setup, the injected current will move in both directions on the wires. Therefore, care must be taken to interpret the results correctly.

c. Inductive injection.

(1) Current transformer. Figure 6-5 shows a way to inject current onto a cable by using a current transformer. In most cases, the transformer induces currents onto the cable shield and the shield induces the current onto the internal conductor according to the cable transfer impedance.

(2) Advantages of inductive injection. Inductive injection requires larger currents than are used in direct injection, since the shield typically gives more than 20 decibels of isolation. However, this method has several advantages. Impedances between the wires and between the wires and ground do not have to be determined and simulated. The cable does not have to be disconnected, and current induction onto the internal wires better simulates an actual HEMP environment.

(3) Other methods. Several other methods use this same principle. In one, wires are placed next to the cable to be injected. Currents produced in

these wires will induce currents in the cable in much the same way as a transformer, but with no need for a toroidal current transformer. Another method is to inject a current directly onto the cable shield, which induces a current on the internal conductors.

d. Methods of current injection testing. Current injection tests are commonly used to assess penetrations and other discontinuities in a shielded enclosure. Included are bonding tests of penetrating conductors, bonding impedance measurements for enclosure attachments to ground, transfer impedance measurements and other common tests for cable shield assemblies, fiber optic data links, EMP/EMI filters, and terminal protection devices. It should be noted that some current injection tests may disrupt normal facility operations. TPD tests also could result in equipment damage. Therefore, tests on an operating facility must be scheduled for the "off" times, conducted on a different channel, or otherwise arranged to avoid interference. In the case of TPD tests, if potential damage to equipment cannot be allowed, the equipment must be disconnected and replaced with an equivalent load. If the equipment is not sensitive to voltage breakdown at the test voltage, limiting the current may be enough protection.

(1) Penetrating conductor drive test.

(a) The direct drive test is an effective measure of current attenuation due to bonding the cable shield or penetrating conductor at the enclosure wall. Direct drive testing can be used over a range of frequencies below 10 megahertz.

(b) Figure 6-6 shows a typical setup for the direct drive test. The source can be any signal generator with enough output to conduct the test. The detector is a current probe. The shield of the coaxial feed line is connected to the coaxial drive cylinder through a matching resistor to terminate the generator output. The coaxial drive cylinder is a split cylinder that can be clamped around the penetrating conductor. This cylinder terminates at the shielding wall in the characteristic impedance for the transmission line formed by the penetrating conductor and the drive cylinder.

(c) This method measures the attenuation of conducted current induced on the penetrator. The attenuation provided is defined by--

$$A = 20 \log \frac{I_1}{I_2} \text{ db} \quad (\text{eq 6-1})$$

where I_1 is the current on the external part of the conductor and I_2 is the current passed through to the inside of the enclosure.

EP 1110-3-2
31 Dec 90

(d) A realistic test configuration requires careful simulation of the source impedance and distributed coupling events. It also may be hard to obtain matching networks that will maintain good operating conditions for the test at higher frequencies (above 30 megahertz). Besides difficulty in matching the impedance for this test, explaining test results at high frequencies (above about 10 megahertz) is a problem. Therefore, care must be taken if these tests are used above 10 megahertz.

(2) Gasketed access panels. Transfer impedance and transfer admittance of gasketed access panels.

(a) EM energy can pass through an imperfect shield seam (gasket) by three different coupling mechanisms: diffusion, magnetic field coupling, and electric field coupling.

(b) The first two mechanisms can be grouped together and their effect can be represented by a transfer impedance. The third can be represented by a transfer admittance. In general, how well a shield performs can be shown by combining the transfer impedance with the transfer admittance. However, the transfer admittance leakage term is small compared with the transfer impedance term. Hence, only a method for measuring the transfer impedance is discussed here.

(c) The transfer impedance of an element (for example, an access panel, or port) is independent of how the shield assembly is incorporated into an overall shielding system. Transfer impedances can be measured in a test fixture and the results can be used in analyses of the system's overall shielding performance. The test fixture is of coaxial geometry, fully enclosing the shielding element being tested.

(d) Figure 6-7 shows the setup for measuring the transfer impedance of a gasketed access panel. External surfaces of the panel and shield carry a current, I_0 . This current must flow across the seam before returning to the signal generator. A voltage, V , is induced between the panel, seam, or aperture being tested and the shield. This voltage is then measured by a suitable detector. (This method is documented in ref 6-3.)

(e) The frequency range of validity for the coaxial test fixture is limited by the transverse electromagnetic (TEM) propagation properties of the fixture. At an upper bound frequency for which the wavelength is about equal to the circumference of the fixture's base, higher order modes appear. These modes disrupt measurement reliability. Hence, the frequency is limited on the higher end such that the wavelength is greater than the circumference of the fixture. The frequency range for this test is then from d.c. to the upper bound frequency (about 500 megahertz).

(f) This technique does not directly measure the SE of a given seam, access panel, ventilation panel, or other leakage point. It does measure the leakage due to surface currents on the enclosure. Results of measurements

EP 1110-3-2
31 Dec 90

from this method therefore must be explained in terms of new specifications for allowed transfer impedance or the results must be converted to an attenuation factor. Assuming the latter, since it is easier to measure and interpret the voltage ratio of applied voltage to that detected inside the shield, the attenuation factor is approximately--

$$V_2/V_1 = 50 w^2 C_1 C_2 Z_T \quad (\text{eq 6-2})$$

where V_2 is the output voltage; V_1 is the input voltage; w is the radian frequency; C_1 is the capacitance per unit area between the shield and the outer shield environment; C_2 is the capacitance per unit area between the shield and the inner conductors of the test fixture; and Z_T is the transfer impedance.

(3) Seam sniffer test.

(a) This test is a qualitative evaluation of SE. It requires a strong source of low-frequency exciting current on the enclosure (not necessarily in the HEMP spectrum) and the "seam sniffer" as a receiver for detecting leaks. The source is usually connected across opposite corners of a shielded enclosure with a magnetic field leakage detector probe (seam sniffer) inside to scan for anomalies (magnetic field leakage). To use a seam sniffer, the seams to be tested must be accessible.

(b) Advantages of this type of test are its simplicity, low cost, and the speed with which it can be performed. Also, these tests can be done at both subsystem and system enclosure levels, providing a method which is useful over the life of the system. The purpose of seam sniffer tests is to detect field leakage in a shielded system. They do not measure the plane wave SE of the enclosure. The seam sniffer is a useful tool in hardness surveillance to detect degradation of enclosure SE. In this testing phase, measured values are compared with baseline data for the enclosure.

(c) The sniffer also can be used to detect leakage of shielded cables/connectors by driving an internal source wire with a current generator and measuring the external magnetic fields.

(d) Another use for the sniffer is to measure leakage at door seals, access panel gaskets, and other points which results from surface currents induced on the enclosure.

EP 1110-3-2
31 Dec 90

(e) Commercially available sniffer models operate only at a single frequency, which somewhat limits their usefulness in determining leakage over the HEMP spectrum. However, if baseline data are available, degradation can be detected easily.

(4) EMP cable shield assembly tests.

(a) Performance requirements. Cable shield assembly performance requirements can be verified by combining analysis with tests. The type of analysis and test--and the balance between the two--will depend on the performance requirements for the cable shield assembly. A test specification will be derived from the performance specification. Verification of the test specification will, in turn, allow verification of the performance specification through an analysis connecting the two. The accuracy of the verification therefore depends on test and analysis accuracy. The analysis and associated test requirements depend on the following factors: kind of performance specification, cable configuration (one-dimensional or multidimensional), environment (wide-band pulse or narrow-band pulse), and test configuration (method of excitation, cable termination [shield and internal], configuration of internal conductors, and measurements). These factors are not all independent. For example, the test configuration depends partly on the environment.

(b) Performance specification. Each specification describes the performance level environment and accuracy to which the performance must conform. The performance specifications can be stated in terms of either transfer impedance or SE. The verification test will depend on the category and measurement technique.

(c) Cable configuration. Cables can be divided into two categories: one- and multidimensional types. The one-dimensional category includes all cables that have only two ports (connectors). The multidimensional category includes all cables with more than two ports. Branched cables and multiport harnesses fall into the second class. The object of the verification test is to expose each section of the shield to a controlled, measurable environment. This goal becomes harder to meet as the dimensionality of the cable increases.

(d) Cable environments. The cable shield environments used in the test can be divided into two categories: narrow-band CW or broadband pulse. CW environments are preferred due to the relative simplicity of the required instruments. However, both the amplitude and phase of internal-conductor-induced voltages and currents must be measured to assess the time domain (pulse) response. Various components of the environment can be used in the test, including E-field, H-field, conducted current, and any combination.

(e) Excitation method. The cable and connector shields can be driven in one of three configurations using: 7 quadraxial, triaxial, and coaxial test fixtures. These configurations usually are coupled directly to

the environment generator. The environment can thus be classified as a conducted surface environment.

(f) Terminations. Terminations of the inside cable conductors can vary among short, open, and matched terminations of the coaxial regions formed by the test fixture. Matched terminations are preferred to eliminate reflectors on the cable.

(g) Demonstration and test methods. Table 6-5 lists different methods for doing demonstrations and tests for quality assurance. An electrical schematic of the three cable-only methods is shown in figure 6-8. The system-level method applies to a wide range of shielding elements. Hence, it cannot be shown by a simple diagram. However, it is a good alternative for ensuring quality after production. Direct injection can be used in all cases. An internal return can be used in the triaxial configuration; it is required in the coaxial configuration. However, the generator and receiver locations could be exchanged to yield a configuration in which the shield is exposed to a localized field and the response is measured in terms of the internal currents, voltages, or both. The system-level configuration can use direct or radiated methods of exposure. The cable complexity is limited in the quadraxial and triaxial configurations. Although fixtures have been built to test branched cables in each of these configurations, the cost increases for very complex cables. The fixture termination often is the characteristic impedance of the fixture. However, in the triaxial configuration, a shorted termination often is used along with pulse excitation. Cable terminations are optional. Open, short, matched, actual cable loads, or all four are possible in all test configurations. However, the shorted terminal configuration usually is used in the coaxial test. The response measurement depends on the terminal configuration in all but the coaxial method. In this method, the measured component is usually a magnetic field. The E-field component could also be measured, though, depending on conditions.

(5) Nonconducting data links. Nonconducting data links are a desirable alternative to conducting cables in many applications. Since fiber optic cables and dielectric waveguides are nonconductors, HEMP and TEMPEST fields will not couple to them and hence no surface current is induced if the fiber optic cable or dielectric waveguide is not covered by a metal layer for physical protection. For the nonconducting case, the HEMP and TEMPEST protection is reduced to control over the POE of the link into a shielded enclosure. Nonconducting links of the type referred to (optical or dielectric waveguide) are afforded POE control by waveguide-beyond-cutoff entry tubes through the enclosure wall. These entry tubes are apertures and are tested using the aperture test techniques discussed in paragraph 6-10. To evaluate leakage of these entry tubes properly, they must be filled with the dielectric material used for the data link because the tube plus data cable represent a dielectrically filled waveguide which affects the cutoff frequency.

(6) EMP and TEMPEST filter tests.

EP 1110-3-2
31 Dec 90

(a) Response characteristics. The standard approach for measuring the response characteristics of an EMP filter is shown in figure 6-9. The signal generator should either be swept through the entire frequency range of the pass and stop bands of the filter or enough discrete frequency points should be measured to construct a smooth, continuous response characteristic. The d.c. supply should be set to deliver the full rated d.c. load or the d.c. equivalent RMS for a.c. filters. Buffers in the d.c. circuit are provided to isolate the d.c. supply from the RF signal. The receiver measures the filter's attenuation as the magnitude $10 \log P_{\text{INPUT}}/P_{\text{OUTPUT}}$. For filters that will be used to pass digital information, the receiver will measure the phase difference of the input and output signals. This phase difference can be used to find the frequency-dependent delay curve for the filter. For filters designed to transmit a.c. or d.c. power, the voltage drop can be measured as described in MIL-F-15733 (ref 6-4) or by the response measurement shown in figure 6-9. The main drawback of this method is that it uses matched input and output terminations for the filter. When active loads are connected to the filter, they will not remain matched over the entire HEMP and TEMPEST spectrum and the response to actual load conditions will be unknown. Another method is to make a detailed network synthesis to generate the response characteristic. In this case, the scattering ("S") parameters of the filter are obtained through reflectivity measurements using the test setup shown in figure 6-10. The filter response for any load (active or passive) can then be determined analytically. The "S" parameters reduce to voltage reflection and transmission coefficients when characteristic load and source impedances are used (ref 6-5).

(b) Dielectric withstanding voltage. This test can be done as described in MIL-F-15733. The dielectric withstanding test voltage should be 2000 volts or greater.

(c) Source-load impedances. The response characteristic also can be measured using the instruments shown in figure 6-11 to determine the effects of variable impedances. Characteristics should be measured for the frequency range representing the entire pass and stop bands of the filter. The output data will be much like that described in paragraph (a) above. If the response characteristics are measured this way, the test prescribed in (a) above can be ignored.

(7) Conducted transient HEMP environment test. The test configuration shown in figure 6-12 can be used to subject the EMP filter to the transient environment caused by a HEMP. The detector should be used to ensure that no undue saturation effects occur. The filter should be exposed to a prescribed set of damped sinusoidal drive waveforms, as determined from the HEMP cable-induced analysis:

$$F_{1-N} (Q_{1,N}) A_{1-N} \quad (\text{eq 6-3})$$

where F_{1-N} is a set of fundamental frequencies as a function of damping, Q_{1-N} , and amplitude, A_{1-N} . After this test, the response characteristic should be verified as described in paragraph d above.

(8) Terminal protection device (TPD) tests. To ensure that the EMP TPD conforms to the manufacturer's specifications throughout its life cycle, quality assurance and HS requirements should be developed as described in paragraphs (a) through (k) below. The inspection procedures are divided into three groups: visual inspection, analysis, and testing. Compliance with each specific TPD requirement depends on one or more of these classes. In some instances, different inspection requirements are stated.

(a) Transient power reduction. The EMP transient power reduction of the TPD should be measured for performance evaluation as shown in figure 6-13. The optional bias supply should be set to give the full rated load or the d.c. equivalent (RMS) for a.c. circuits. These values should be measured to assist in device selection during the design phase. A similar test using current injection sources should be performed during the certification phase to ensure proper installation of the TPD. If the configuration shown in figure 6-13 is used, the protected and unprotected powers can be found from--

$$P = E^2/R \quad (\text{eq 6-4})$$

where P is the protected or unprotected power in watts; E^2 is the area under the square of the voltage-versus-time curve; and R is the load, with 50 ohms chosen for convenience. Since MOV service life can be reduced by these tests, it is recommended that a current-limiting resistor be placed in series with the source (more than 100 K ohms) and only the breakdown observed. The pulse generator must be able to supply a square-wave pulse with the following characteristics: risetime, 4 kilovolts/nanosecond maximum; amplitude, 3 to 5 times the TPD static breakdown as a minimum; and pulse width, 10 microseconds. The pulse test should be conducted a minimum of 5 times on a statistically significant sample for each device to determine average operating characteristics. Lead lengths in the test fixture must be kept short (low inductance) to characterize the TPD (ref 6-5). Power line surge arrester tests on an active power line must be synchronized to the 60-hertz power line voltage to avoid problems with power follow-through currents. To do this, the direct injection pulser is synchronized to fire at the zero crossing of the 60-hertz signal. Due to the short duration of the HEMP injection pulse synchronized to the zero crossing, the surge arrester will recover (extinguish), removing the possibility of follow-through currents. This method should be followed for all TPD tests on active power lines. Power reduction also can be measured using the setup shown in figure 6-14. In this case, the load should simulate the actual protected subsystem impedance. The power can be found from--

EP 1110-3-2
31 Dec 90

$$P = \text{integral, from 0 to } t_D, \text{ of } V(t) i(t) dt \quad (\text{eq 6-5})$$

where t_D is pulse duration and the power-versus-time curve is the point-by-point product of the voltage ($V(t)$) and current ($i(t)$) versus time curves.

(b) Impulse ratio. The static (d.c.) breakdown voltage should be measured using the setup shown in figure 6-15. The impulse ratio should be calculated as the ratio of the voltage at which breakdown occurred in the test described in (a) above to the d.c. voltage at which breakdown occurs as measured in figure 6-15. The impulse ratio represents the response time performance of the device when subjected to the fast rate of rise-time pulses. This ratio is a good indicator of how the device will respond to the HEMP-induced signal. It should be measured for several different rate-of-rise pulses to evaluate the protective system design. The impulse ratio is given by--

$$IR = \frac{V_{b \text{ impulse}}}{V_{SB}} \quad (\text{eq 6-6})$$

where $V_{b \text{ impulse}}$ = voltage of breakdown for a given impulse rise time and V_{SB} = voltage for static breakdown.

(c) Clamping voltage. This is the steady-state voltage appearing across the device after breakdown has occurred, as determined from the voltage curve given in paragraph (a) above.

(d) Operating impedance. This is defined as the ratio of device voltage to device current at rated current through the device.

(e) Bipolar performance. The pulse power attenuation should be measured as described in (a) above for both positive and negative pulse polarities for bipolar devices. For unipolar devices, the inability to suppress surges of opposite polarity is evident from the TPD's physical/electronic properties.

(f) Isolation impedance. The isolation impedance of the TPD should be measured using an impedance bridge. This measurement should be taken after the normal operating voltage has been applied for a minimum of 1 minute. Both the device resistance and the capacitance should be determined.

(g) Turn-off characteristics. If the optional d.c. supply is used as in (a) above, the turn-off time can be measured directly from the voltage curve for different bias conditions. If the optional d.c. supply in (a) above is not used, the operating circuit can be analyzed to ensure that the breakdown will not be sustained due to the normal characteristic voltage level and source impedance.

EP 1110-3-2
31 Dec 90

(h) Shunt capacitance. The shunt capacitance should be measured as in paragraph (f) above using a capacitance bridge.

(i) Insulation resistance. The TPD insulation resistance can be considered satisfactory if no external breakdown occurs during the pulse power test (para (a) above) and if the sample devices continue to operate within specifications after 5 pulses.

(j) Environment. The TPD should be tested as described in MIL-STD-202 (ref 6-6), for proper operation under natural environmental conditions.

(k) Grounding, mounting, and lead length. Visual checks should be done to ensure proper grounding and mounting as required. A visual check should also be done to ensure a minimum lead length in installations. The lead length-to-width rates should be such as to provide a low inductance band (length less than 3 times width).

6-12. Shielding effectiveness testing.

a. Overview.

(1) Three types of SE tests. Among the enclosure tests that call for the production and measurement of EM and RF fields are three types of SE tests. These tests correspond to three types of fields. The impedance of the EM and RF fields is given by the ratio E/H , where E and H are the magnitudes of the electric and magnetic fields, respectively. For low-impedance fields, this ratio is small; thus, low-impedance fields are termed "magnetic." If the ratio is large, E is much larger than H and the high-impedance field is termed "electric." When the ratio of E to H is equal to the impedance of the medium in which the field exists, the wave is called a "plane wave."

(a) The field impedance can be related to the nature of the field's source. In general, plane wave excitation results from fields for which sources are spatially far from the object being excited. "Far" is a relative measure that depends on field frequency.

(b) In contrast, electric or magnetic fields are important for closer object-to-source distances. Thus, for HEMP, the system outer skin will be excited mainly by far-field plane waves whereas internal enclosures are excited by fields generated nearby, such as fields that result from openings and those caused by currents flowing on cable shields. When external system surfaces diffract and reflect the EM energies, these "secondary" sources will result in near-field electric/magnetic waves.

(2) Choice of measurement method. Another factor has bearing on the choice of measurement method according to field type. In general, the SE of an enclosure will be least for magnetic fields at low frequencies (less than

EP 1110-3-2
31 Dec 90

100 kilohertz). The plane wave SE and electric field SE increase in that order.

(3) Overall enclosure SE. An enclosure can be formed from several different shielding materials of differing SE. The overall SE for the enclosure will be compromised by the need for certain points of entry (POEs) as well as undesired leaks at joints, openings (apertures), and access panels. Verification tests are done mainly to assess the SE of an overall enclosure, such as a shielded drawer, rack bay, or enclosed system, rather than to assess the intrinsic SE of a given material. Therefore, tests on the POEs in an enclosure are normally emphasized.

b. Procedure and description. Standard test procedures are MIL-STD-285, IEEE-229, and NSA-No. 65-6 (ref 6-7). A good comparison and review of these methods are in reference 6-8. The first two methods are being revised to reflect the use of more modern test equipment and antennas. The most recent method should be used for testing. Further guidance on these methods is in reference 6-9.

(1) Low-impedance (magnetic) field SE. The SE of low-impedance fields can be measured in the frequency range of 100 hertz to 10 megahertz. It should be noted that these tests do not provide the plane wave SE of the enclosure but are useful in quality assurance of the structure as built. The tests described for this measurement are the small-loop-to-small-loop, Helmholtz coil, and parallel strip line methods. The proper frequency range for each method is noted under the related paragraphs below. These methods require a calibrated 50-ohm step attenuator. A calibrated signal generator can be used to calibrate the attenuator. This attenuator should be suitable for measuring insertion losses above the shielding requirements specified for the tested element.

(a) Small-loop-to-small-loop method. This test evaluates the enclosure response to sources near its walls and is especially useful for assessing doors, seams, bonds, and absorption loss of the material. The small-loop-to-small-loop test provides a uniform measurement from 100 hertz to about 10 megahertz. Figure 6-16 shows the equipment arrangement for this test. An option to this test setup might be an XY plotter, which would be used along with the receiver to record the attenuation at a prescribed set of receiving antenna locations to determine the peak and minimum attenuations as well as an average value. The transmitting antenna must be located external to the enclosure and placed 0.305 meter from the wall tested. The receiving antenna must be inside the wall being tested (fig 6-16). The receiver loop should be oriented for maximum coupling to the transmitter loop for each measurement location. Low-impedance shield leakage tests should be done at the following places: parallel to vertical seams at a minimum of three points along the longitudinal axis of the enclosure; parallel to horizontal seams at a minimum of two points around the enclosure; parallel to opening seams of all access panels and doors; and centered over each type of window or aperture. Figure 6-17 shows typical proposed measurement points for access panels and

corners of the enclosure. The figure also indicates the distances antennas are to be placed from the seam being tested. An option is to use an XY plotter (para (1) above) and scan the detecting loop over a prescribed test path. SE would be recorded as a function of position inside the enclosures. The attenuation (peak, minimum, and average) can be read directly from the plot, provided the plotter was calibrated correctly. The SE for this procedure is defined as the decibel setting of the attenuator needed to obtain a constant reference level at the detector with and without the shielding. The attenuation is--

$$A = 20 \log_{10} (E_1/E_2) \quad (\text{eq 6-7})$$

where E_2 and E_1 are the voltages induced in the receiving antenna with the shielding in place and with it removed, respectively, without changing the relative separation or remaining environment between the antennas. To measure E_1 (no shielding between antennas), the antennas must be placed in the same relative position with respect to each other as well as to the cables and equipment required in the test. The setup is the same for measuring E_2 . Care must be taken to ensure that E_1 is measured at a point relatively free of reflections. There are several advantages to this method. The impedance of the fields radiated by the loop can be calculated by well known formulas, thus making overall theoretical calculations easier. Also, since the impedance of the field is a function of the loops' separation, the impedance level can be varied by spacing the loops closer or farther apart. The small-loop method can be used on widely varying sizes of enclosures, from system to drawer levels. Another good point of this method is that a small detecting loop minimizes the effect of instruments on the measurement. In addition, fields can be produced either inside or outside the enclosure so the experimental setup is flexible. Finally, no special equipment is needed for this test and the setup is relatively simple. Some severe drawbacks of the small-loop test tend to negate the advantages. First, the generated field is highly nonuniform. Hence, unless accurate alignment is maintained between transmitting and receiving antennas at each test point, the SE measurements will be hard to interpret. Also, because the field is nonuniform, it is difficult to illuminate hard-to-reach joints, making them harder to test. Another drawback is poor dynamic range, which results from inadequate field strength for a detector at a distance much greater than the loop diameter. The field coupled between two loops at close spacing varies inversely as the cube of the loop centers' separation. Thus, small errors in the measurement of loop spacing may cause errors in seam leakage measurements, making results less repeatable. Repeatability for this method is normally ± 3 decibels, depending on the operator's skill. There are frequency limitations as well. For example, large errors can occur if a singly loaded loop is used unless its diameter is less than 0.01 wavelength. Hence, for a 12-inch receiving loop, accuracy can be kept within acceptable limits only at frequencies lower than 10 megahertz.

EP 1110-3-2
31 Dec 90

(b) Helmholtz coil to small loop method. This method produces a uniform field distribution over the entire enclosure, with coils completely surrounding the shield enclosure. The method measures SE from 3 kilohertz to 1 megahertz when SE is as defined for the small-loop method. Figure 6-18 shows the equipment arrangement for this test. The small-loop detector can be either a small-diameter loop (circumference small compared with a wavelength at the test frequency) as in the small-loop-to-loop test or a seam sniffer. The seam sniffer has its own display; for the loop-type test, see the detector instrumentation described for the small-loop-to-loop test. The Helmholtz coil method is useful for detecting leakage of the enclosure due to seams, doors, panels, and other apertures, but does not provide the plane wave SE of the enclosure. Therefore, it is a good tool for QA and HS. It is also useful as an HS tool for comparing measured values with the baseline data. As figure 6-18 shows, the method applies only to accessible free-standing enclosures. It could be applied to facilities for HS or inaccessible enclosures if the loops were installed permanently on the facility/enclosure with drive terminals accessible. Specific advantages of this method are the following. The field uniformity is good over a relatively large area and the intensity of the generated field is fairly strong, giving good dynamic range. Locating seam and joint defects is made easier by the field uniformity. Therefore, measurement time and cost are relatively low compared with other methods. Also, because the orientation and position of the Helmholtz coil remain constant, the measurement is very repeatable. One of the biggest drawbacks of this method is the relatively complex test setup. The size of the test enclosure is limited with increased frequency (loop circumference must be small compared with test frequency wavelength) because field uniformity can only be maintained by reducing the Helmholtz coil dimension at higher frequencies. Perhaps even more important is that leakage can be detected through seams and joints that are parallel to the direction of current flow in the Helmholtz coil. Therefore, to ensure that the total enclosure is covered, at least three orientations of the coil are needed. These correspond to three orthogonal orientations of all leaky joints. Another consideration in evaluating this method is that it is clumsy to use with large and even medium-sized enclosures. The size of the Helmholtz coil needed for a uniform field can become quite large for many test setups, which limits the upper frequency for testing.

(c) Parallel strip line method. This method is essentially a current injection scheme in which a current is induced on one side of the enclosure and detected on the other. As an alternative to the methods just discussed, it is well suited for testing seams and joints (ref 6-10). A shortcoming of this method is that the plane wave SE is not determined--only the attenuation through the surface and leakage at joints and bonds is assessed. The parallel strip line method measures SE from 3 kilohertz to 30 megahertz. Figure 6-19 shows the typical test arrangement for this method. The load resistors usually are 50 ohms with a 50-ohm signal generator as the source. Typical points where measurements should be taken are access panels and doors, bonding seams, and gaps. The drive and coupled currents are measured with a standard commercial current probe. This parallel strip line

EP 1110-3-2
31 Dec 90

method measures attenuation due to the enclosure material (absorption loss caused by skin effect) and leakage due to joints, gaps, seams, and other POEs. The attenuation is given by--

$$A = 20 \log_{10} \left(\frac{I_1}{I_2} \right) \quad (\text{eq 6-8})$$

where I_1 is induced test current and I_2 is the measured current transferred through the surface. This method has advantages mainly in that it uses direct drive, in which the shield elements under test are tightly coupled to the test source. This tight coupling provides a low-cost, efficient, fairly simple technique. Other advantages are the ready supply of test equipment and the direct use of test results in evaluating the leakage of joints, seams, and other areas. The parallel strip line method allows specifications to be set and tested before the system is built. This allows design changes before and during system construction. Some major drawbacks of this method result from the following properties. The method is hard to use at high frequencies (above 30 megahertz). Also, it tests only the penetration loss through the enclosure surface due to diffusion and leakage at joints and seams. When the enclosure is illuminated by radiated waves, this method does not account for the reflection loss of the surface, which can be substantial compared with the penetration loss. In general, this method is best suited for testing seams, joints, and other leakage points of an enclosure during all phases of the system's life cycle. The seam sniffer approach is simpler to use in detecting seam leaks but is not as well controlled.

(2) High impedance (electric) field SE.

(a) The method most commonly used for measuring the SE of enclosures with high-impedance fields is the antenna-to-antenna test described in MIL-STD-285 (ref 6-2). Test frequencies are limited to 15 megahertz due to the standard test arrangement. For a high-impedance field, $(\beta)r = 2(\pi)r/\text{wavelength} \ll 1$. For the antenna-to-enclosure distance specified in MIL-STD-285 ($r = 12$ inches), the frequency is limited to 15 ohms to maintain high impedance. The range can be extended to higher frequencies by using antennas with larger apertures (for example, parallel plate lines with open load impedance) to generate a field impedance that differs from the plane wave impedance of 377 ohms. At high frequencies for which standing waves can affect measurement accuracy, a method for averaging may improve results.

(b) The leakage due to high-impedance fields can be measured for an enclosure in the frequency range of 3 kilohertz to 100 megahertz using the antenna-to-antenna method and adjusting the antenna's length and distance from the enclosure. This tests the performance of shielded walls located near the electric field source. It is especially useful for testing seams, gaps, and

EP 1110-3-2
31 Dec 90

bonding joints. Since very little leakage of this type occurs below 10 megahertz, tests should be conducted only above 10 megahertz.

(c) Figure 6-20 shows the equipment arrangement for this test. Details can be found in MIL-STD-285.

(d) The transmitting antenna must be placed outside the enclosure, 0.35 meter from the shielded wall. The receiving antenna must be inside the enclosure, 0.35 meter from the wall. The receiving antenna is placed inside to minimize interference from other sources that would influence the measurements. The antennas must be oriented (vertical and horizontal polarizations) for maximum signal in each measurement of E_2 .

(e) High-impedance field leakage tests should be done at the following locations: parallel to vertical seams at a minimum of X points along the longitudinal axis of the enclosure; parallel to horizontal seams at several points around the enclosure; parallel to opening seams of all access panels and doors at several points; and centered over each type of window or aperture. The number of test points is a matter of engineering judgment based on seam length, seam fastener spacing and related factors.

(f) The shield leakage for this procedure is defined as in the small-loop method (para 1 above).

(g) This method is useful for the following reasons. First, the wave impedance from a dipole can be calculated easily from well established formulas. The wave impedance of a dipole (Z_D) is given by--

$$Z_D = \frac{E(\theta)}{H(\phi)} = n \left(\frac{1 + jBr - B^2 r^2}{jBr - B^2 r^2} \right) \quad (\text{eq 6-9})$$

where theta and phi are coordinate system variables; n is 377 ohms; B is $(\pi)/\text{wavelength}$; and r is the distance from the antenna. In addition, the test equipment is readily available and the setup is relatively simple. Another good point is the large range of enclosure sizes that can be tested.

(h) This method also has drawbacks. The field is very nonuniform, which makes test results hard to interpret. Also, monopole antennas can receive reflections from the local environment, making reliable and repeatable measurements quite difficult. In addition, the monopole is subject to the same narrow bandwidth as the dipole. Finally, for good shields, a large dynamic range is required.

(3) Plane wave SE. SE measurements using plane waves provide both the reflection and absorption loss of an enclosure. The plane wave SE can be measured using the methods described in paragraphs (a) and (b) below.

EP 1110-3-2
31 Dec 90

(a) Antenna method. This method uses common sensors such as rod, dipole, horn, or other directional antennas for detection. Common types of source antennas used are: small-loop, monopole, dipole, conical logarithmic spiral, pyramidal horn, and log periodic. This method measures an enclosure's SE from 100 kilohertz to 1000 megahertz. At the lower frequencies, the loop, rod, or dipole antenna can be used. At higher frequencies, horn log-spiral or log-periodic antennas are used. Figure 6-21 is a sample setup using a dipole antenna. Other antenna setups are similar with possible variations in the relative separation of antennas and shielding enclosure wall. Antennas shall be oriented (vertical or horizontal polarization) for maximum coupled signal in each frequency measurement of E_2 for the shielding enclosure. Plane wave SE tests should be done at the following locations: centered at the midpoint along the longitudinal axis of the enclosure, both sides, and centered along the lateral axis of the enclosures, both sides. The SE for the antenna method is, again, as defined for the small-loop test. To achieve the required plane wave field, the test object must be in the far field of the antenna. To achieve the required dynamic range, high output power or good receiver sensitivity is required. An alternative is to use a phase-locked receiver so very narrow bandwidths and a wide dynamic range can be achieved. The antenna method can be assessed based on the types of antennas used to generate and detect the fields. The small-loop antenna method is subject to the same basic advantages and drawbacks as the small-loop-to-small-loop method for low-impedance fields. Advantages of using monopole and dipole antennas are test simplicity, readily available equipment, and easily tuned antennas. Shortcomings are its susceptibility to reflections from local objects, observers, and other environments, making measurements less repeatable and less reliable. Also, the impedance of the dipole may change with application configuration, leading to a loss of antenna efficiency. Another drawback of this method is the relatively narrow antenna bandwidths which make it necessary to use adjustable antennas or several antennas. With conical logarithmic spiral antennas, the main advantages are increased antenna bandwidth and the ability to generate circularly polarized fields that minimize the seam directionality effects found with linearly polarized waves. A rather severe drawback of this method is the large size of antenna needed for most of the HEMP spectrum.

(b) The parallel plate method. This method generates uniform fields of low impedance, high impedance, or plane wave, depending on how the parallel plate line is terminated at the load end. Termination in a short circuit yields a low-impedance field; termination in an open circuit gives a high-impedance field; and termination in the line's characteristic impedance produces a plane wave impedance field. This method has greatest use in testing relatively small enclosures due to implementation problems associated with constructing large volume parallel plate lines. For large enclosures, it is possible to use the conducting floor as the lower plate (that is, the enclosure bonded to the lower plate of the line). The SE measurement range is from 3 kilohertz to 20 gigahertz. Figure 6-22 shows a typical test setup for the parallel plate method. The detector is a small-loop antenna with attenuator and receiver inside the enclosure. More complete details of this

EP 1110-3-2
31 Dec 90

method and how to construct the parallel plate transmission line can be found in Air Force Systems Command Handbook DH 1-4 (ref 6-11) or in AFWL Sensor Simulation Notes (ref 6-5). Measurements shall be taken with the enclosure oriented in the following directions: longitudinal axis parallel to the axis of the parallel plate; longitudinal axis perpendicular to the axis of the parallel plate; and lateral axis perpendicular to the axis of the parallel plate. The SE for this method is defined by equation 6-7. Care must be taken that the relative dimensions of the enclosure under test do not exceed approximately two-thirds the height of the parallel plate line. This method may be the best overall test for enclosure SE. There is no limit to enclosure size as long as the height restriction is met. Thus, very large lines are needed for large enclosures. One of the main advantages is that the field generated is relatively uniform within the bounds of the practical parallel region. For large enclosure measurements, a practical parallel strip line can be constructed of a few (four or five) parallel wires placed along either side of the enclosure. Other advantages of this method include all of those for the loop antenna tests as well as several more related to commercially available field sensors developed jointly by AFWL and the EG&G Corporation. An important feature of the sensors is that they can be calibrated based on theory with a high level of accuracy. In addition, these sensors are standard in the EMP community and are very credible. They offer a wide, useful bandwidth with more predictable performance than other loop test methods. The main disadvantage is a relatively poor response at low frequencies.

c. SE testing summary. Table 6-6 is a general summary of the frequency ranges and uses of the tests specified in MIL-STD-285, IEEE 299, and NSA-No. 65-6. In military HEMP and TEMPEST shielding, MIL-STD-285 often is the specified test. However, practical testing guidance is presented more clearly in IEEE 299. The NSA specification is normally cited for testing enclosures that house electronic equipment and that produce their own EM emanations. In this case, the shielded enclosure is used chiefly to reduce the equipment-produced emanations.

6-13. Bonding impedance measurements.

a. Purpose. The purpose of bonding impedance measurements is to ensure that a low-impedance connection is obtained to the system ground. This connection is required for all protection components that must be ground-referenced, such as filter elements and surge arresters.

b. Available techniques. Several test techniques are available, including Q factor measurements of a resonant circuit with and without the unknown impedance, balanced bridge measurements, and insertion loss measurements.

c. When performed. These bond impedance measurements should be performed as part of the QA testing during the equipment installation/ facility construction phase and whenever protection components or equipments are removed or replaced as part of the HS/HM activity.

d. Q factor comparison. This method tests bonding impedance by incorporating the bonding conductor into a resonant circuit and relating the change in the Q of the circuit to the proper impedance value. The major advantage of this test are its usefulness during the full life cycle of the system and the relatively low cost of these measurements.

e. Balanced bridge method. This is a standard method for measuring impedances in which the unknown bond impedance is compared with a known value in a balanced bridge configuration. The advantage of this method is much the same as for Q factor comparison (para d above). A constraint is that, at high frequencies, measurements are limited to 1 ohm or greater. In addition, measurement of lower impedances requires lower operating frequencies.

f. Insertion loss. In this method, the unknown bond impedance is used as a shunt element of a "tee" attenuator. The attenuator is connected between a source and load of known impedance in which the resulting insertion loss can be related to the magnitude of the unknown bond impedance.

Figure 6-23 depicts this measurement.

(1) Principle of insertion loss. The insertion loss method is based on the principle that if the shunt arm impedance of a tee attenuator is low compared to the series arm impedances, the current through the shunt arm will essentially be constant for varying values of shunt arm impedance. For a fixed input voltage to the attenuator, changes in the output voltage are proportional to changes in the shunt arm impedance. The unknown bond impedance is then given by (assuming $R_1 \gg r_1 + j\omega L_1 + Z$, $R_2 \gg r_2 + j\omega L_2$ and a 50-ohm load resistive)--

$$Z = \frac{R_1 (R_2 + 50)}{50} \left(\frac{V_0}{V_1} \right) \quad (\text{eq 6-10})$$

where Z is bond impedance; R_1 and R_2 are isolation resistors; V_0 is the applied drive voltage; and V_1 is output voltage.

(2) Advantage of method. A special advantage of this method is that the measurement system can be used for swept frequency measurements, as indicated in figure 6-23, at great savings in cost and time (ref 6-12).

6-14. Cited references.

- 6-1. Military Standard (MIL-STD) 285, Method of Attenuation Measurements for Electromagnetic Shielding Enclosures for Electric Test Purposes (U.S. Department of Defense, 25 June 1956).
- 6-2. Institute of Electrical and Electronic Engineers (IEEE) Standard 299, Recommended Practice for Measurement of Shielding Effectiveness of High Performance Shielding Enclosures (1969).

EP 1110-3-2
31 Dec 90

- 6-3. DNA EMP Preferred Test Procedures, DNA 32864 (Defense Nuclear Agency [DNA], February 1977).
 - 6-4. MIL-F-15733, General Specifications for Radio Frequency Interference Filters (U.S. Department of Defense, 15 June 1982).
 - 6-5. AFWL Sensor and Simulation Notes (SSN) Nos. 21, 52-55, 68, 90, 95, 103, 115, 118 (U.S. Air Force Weapons Laboratory).
 - 6-6. MIL-STD-202, Test Methods for Electronic and Electrical Component Parts (U.S. Department of Defense, 21 October 1982).
 - 6-7. NACSEM 5204, Appendix B, Specification NSA No. 65-6, National Security Agency Specification for RF Shielded Enclosures for Communications Equipment: General Specification.
 - 6-8. Document Review, Standard Shielding Effectiveness Test Methods, Test Method 19 (U.S. Army Corps of Engineers, 31 May 1972).
 - 6-9. Axford, R., R. McCormack, and R. Mittra, Evaluation of Applicability of CW EMI/RFI Shielding Effectiveness Test Techniques to Assessment of EMP Hardness of Tactical Shelters, Technical Report M-307 (U.S. Army Construction Engineering Research Laboratory, March 1982).
 - 6-10. Electromagnetic Pulse (EMP) Specification Applications Handbook, AFWL Technical Report 79-162 (U.S. Air Force Weapons Laboratory, May 1980).
 - 6-11. Electromagnetic Compatibility, Air Force Systems Command Handbook DH 1-4, DN6B1 (U.S. Air Force, January 1969).
 - 6-12. Derny, H.W., and K.G. Beyers, A Sweep Frequency Technique for the Measurement of Bonding Impedance Over an Extended Frequency Range (EMI Symposium, 1967).
 - 6-13. Madle, P.J., Transfer Impedance and Transfer Admittance on Gasketed Panel Assemblies; Honeycomb Air-Vent Assemblies, IEEE International Symposium on EMC (1976).
- 6-15. Uncited references.
- BDM Corporation, DNA EMP Course Study Guide, Draft (Defense Nuclear Agency [DNA], April 1983).
 - Jobe, D. J., The Electromagnetic Incompatibility of EMI Filter Test Methods and Test Results, IEEE EMC Symposium Record (1968).

Table 6-1. Test applicability

	Concept exploration phase	Concept validations phase	Design development phase	Construction/installation phase	Operation and support phase
Objective	<ul style="list-style-type: none"> o Evaluate design alternatives o Establish protection requirements 	<ul style="list-style-type: none"> o Validate selected approach 	<ul style="list-style-type: none"> o Validate selected approach/designs 	<ul style="list-style-type: none"> o Quality assurance o Hardness assessment and verification test o Product acceptance 	<ul style="list-style-type: none"> o Hardness surveillance
Analysis/test approaches	<p>Laboratory tests:</p> <ul style="list-style-type: none"> o SE/leakage <ul style="list-style-type: none"> o Large loop o Helmholtz coil o Parallel plate o Radiated fields o Strip line o Small loop <ul style="list-style-type: none"> o Radiated fields o Strip line o Cables <ul style="list-style-type: none"> o Triaxial o Quadaxial o Coaxial o Susceptibility <ul style="list-style-type: none"> o Current injection o Coupling <ul style="list-style-type: none"> o Scale modeling 	<p>Prototype laboratory tests:</p> <ul style="list-style-type: none"> o SE/leakage <ul style="list-style-type: none"> o Large loop o Helmholtz coil o Parallel plate o Radiated fields o Strip line o Small loop <ul style="list-style-type: none"> o Radiated fields o Strip line o Cables <ul style="list-style-type: none"> o Triaxial o Quadaxial o Coaxial o Susceptibility <ul style="list-style-type: none"> o Current injection o Coupling <ul style="list-style-type: none"> o Scale modeling 	<p>Laboratory tests:</p> <ul style="list-style-type: none"> o SE/leakage (as before) o Protection element design <ul style="list-style-type: none"> o Direct injection 	<p>QA/acceptance tests:</p> <ul style="list-style-type: none"> o Shield fabrication <ul style="list-style-type: none"> o Seam sniffer o Visual inspection o Small loop <ul style="list-style-type: none"> o Radiated o High/low impedance o Aperture treatment <ul style="list-style-type: none"> o Radiated o Strip line o Penetrations <ul style="list-style-type: none"> o Shield tech. o Current injection o TPDs <ul style="list-style-type: none"> o Current injection <p>Verification tests:</p> <ul style="list-style-type: none"> o EMP large volume simulators o CW radiated o Parallel plate o Current injection 	<p>SE:</p> <ul style="list-style-type: none"> o Seam sniffer o Built-in Helmholtz coils o CW illuminators o Built-in local current sources <p>Cables:</p> <ul style="list-style-type: none"> o Current injection o Built-in sense drive wires <p>TPD:</p> <ul style="list-style-type: none"> o Current injection o Ground bond tests

Table 6-2. Summary of existing bounded-wave simulators

Name*	Location	Wave- form	Polar- ization	Magnitude	Interaction volume	Status
ALECS	Kirtland AFB, NM	Exo**	V	50 kV/m	30x30x10 m	Operational
ARES	Kirtland AFB, NM	Exo	V	70 kV/m	40x30x20 m	Operational
TRESTLE	Kirtland AFB, NM	Exo	V	50 kV/m	80x80x75 m	Operational
TEFS	WSMR, NM	Exo	V,H	65 kV/m	40x40x10 m	Operational
TEFS	NSWC/WOL, MD	Exo	V,H	50 kV/m	Modular	Operational

*ALECS = AFWL/LASL Electromagnetic Calibration and Simulation Facility; ARES = Advanced Research EMP Simulator; TEFS = Transportable Electromagnetic Field Simulator.

**HEMP double exponential.

EP 1110-3-2
31 Dec 90

Table 6-3. Summary of radiating wave simulators

Name*	Location	Wave- form	POL**	Direct wave magnitude/distance	Interaction area (*Pl. wave)	Angle of arrival	Status
RES I	Portable, Kirtland AFB, NM	Exo***	H	1000 V/m @ 500 m	100 m	Any	Deactivated
RES II	Portable, Kirtland AFB, NM	Exo	V	1000 V/m @ 500 m	100 m	Any	Deactivated
VPD	Kirtland AFB, NM	Exo	V	3 kV/m @ 200 m	Area directly below antenna (non-planar)	Grazing	Operational
HPD	Kirtland AFB, NM	Exo	H	50 kV/m @ 9 m HAC ⁺	ditto	normal	Operational
HDL Biconic	HDL, Woodbridge, VA	Exo	H	15 kV/m @ 100 m	~200 m	10° @ 200 m	Operational
AESOP	HDL, Woodbridge, VA	Exo	H	50 kV/m @ 50 m	~200 m	10° @ 200 m	Operational
VEMPS	HDL Woodbridge, VA	Exo	V	5 kV/m @ 25 m (0.25 MV pulser)	~100 m	Grazing	Operational
EMPRESS	NSWC Solomons, MD	Exo	H	2.2 kV/m @ 300 m (16 m HAG)	~300 m	8° @ 300 m	Operational
EMPRESS	NSWC Solomons, MD	Sur- face	V	4 kV/m @ 300 m	~300 m	Grazing	Operational
EMPSAC	NSWC/NATC Patuxent, MD	Exo	H	8.5 kV/m @ 50 m	~25-50 m	17° @ 50 m	Operational
NAVES	NSWC/NATC Patuxent, MD	Exo	V	11 kV/m @ 50 m	25-50 m	Grazing	In construction
TEMPS	DNA, transport- able	Exo	H	50 kV/m @ 50 m 12.5 kV/m @ 200 m	200 m	10° @ 200 m	Operational

*RES I & II = Radiating Electromagnetic Simulators; VPD = vertically polarized dipole; HDL = Harry Diamond Laboratories; AESOP - Army Electromagnetic Simulator Operations Facility; VEMPS = Vertical Electromagnetic Simulator; EMPRESS = Electromagnetic Pulse Radiation Environment Simulator for Ships; EMPSAC = EMP Simulator for Aircraft; NAVES = Navy EM Simulator; TEMPS = transportable EMP simulator.

**POL = polarization

***Exo = HEMP double exponential.

+Directly below antenna.

EP 1110-3-2
31 Dec 90

Table 6-4. Scaling relationships

Model size

$$D_s = \frac{D_a}{M}$$

Frequency

$$w_s = Mw_a$$

Conductivity

$$c_s = Mc_a$$

Permittivity

$$p_s = p_a$$

Permeability

$$u_s = u_a$$

Propagation loss

$$a_s = Ma_a$$

Propagation phase

$$B_s = MB_a$$

Table 6-5. Summary of quality assurance test methods (source: ref 6-4)

Fixture type	Environment	Injection method	Fixture termination	Cable	Verification	Assurance	Surveillance	Maintenance	Response measurement (A)	Excitation measurement (B)	Measure of shielding effectiveness
<p>Quadraxial (trough): Four concentric conductors with cable conductors and shield forming innermost pair. Direct current injection into No. 3. Conductor with return divided between cable shield and outer conductor.</p>	CW	Direct, cable shield external return	Matched	Optional	X	X			Core current and/or voltage	Shield current	A/B
<p>Triaxial: Three concentric conductors with cable conductor and shield forming innermost pair. Cable and/or connector shield are common to both inner and outer coaxial chamber. One chamber is connected to the generator, the other to the receiver. Other chamber may be driven. Receiver may be at generator end, or at opposite end.</p>	Pulse CW	Direct, cable shield, external or internal return	Matched	Optional or short	X	X			Core current and/or voltage	Shield current	A/B
<p>Coaxial: Two concentric conductors, formed by cable conductors and shield. Driven between shield and conductors. Measure external field (sniffer).</p>	CW	Direct internal return	N/A	Short	X	X	X	X	External field	Core current or voltage	A/B
<p>System Level: Environment applied to shielding system either as a radiated field or as a current density on the outer shield enclosure. Measure response at several points inside system. Additional tests are required to isolate points of entry.</p>	Pulse CW	Direct or radiated exposure of system enclosure	N/A	Open and short			X		Core current and voltage	Shield current or field	A/B

6-41

 EPR 1110-4-2
 21 Dec 90

Table 6-6. Comparison summary of shielding effectiveness test methods (source: ref 6-9)

Parameter specified in document	Test categories												
	Magnetic field				Electric field				Plane wave (ultrahigh frequency)			Plane wave (microwave)	
	IEEE 299	IEEE 299	MIL-STD -285	NSA 65-6*	IEEE 299	MIL-STD -285	NSA 65-6*	IEEE 299	MIL-STD -285	NSA 65-6*	IEEE 299	MIL-STD -285	
Test frequency or frequency range	100 Hz to 200 KHz	100 Hz to 20 MHz	150 KHz to 200 KHz	1 KHz, 10 KHz, 100 KHz & 1 MHz	-	200 KHz, 1 MHz, & 18 MHz	1 KHz, 10 KHz, 100 KHz, 1 MHz & 10 MHz	300 MHz to 1 GHz	400 MHz	100 MHz, 400 MHz & 1 GHz	1.7 GHz to 12.4 GHz	-	
Test Method	Large Loop	Small Loop	Loop test (low impedance magnetic field)	Loop test	-	Rod radiator test (high impedance electric field)	Monopole test (electric field)	Dipole test (ultrahigh frequency)	Dipole test (attenuation test for plane waves)	Tuned horizontal dipole test (plane wave)	Microwave test	-	
Primary components tested	Shielded enclosures	Shielded enclosure plus doors, welds, and electrical & air duct filter enclosures	Shielded enclosure	Shielded enclosure	-	Shielded enclosure	Shielded enclosure	Shielded enclosure	Shielded enclosure	Shielded enclosure	Shielded enclosure	-	
Secondary components tested	Doors, welds and electrical filter and air duct filter enclosures	Welds	**	**	-	**	**	Door seams, electrical and air duct filter panels, air-vent areas, panel seams, & coaxial cable fittings	**	**	Door seams, electrical and air duct filter panels, air-vent areas, panel seams, & coaxial cable fittings	-	

*All power line filters shall be tested for voltage drop (not to exceed 1%) under full load. They must be operated under full load for ten hours before testing. The increase in temperature of the outer case during this period must not exceed 25°C above the ambient temperature of the room.

**Test method does not contain preliminary procedures for checking enclosure components for leaks which are to be repaired before conducting primary test.



EP 1110-3-2
31 Dec 90

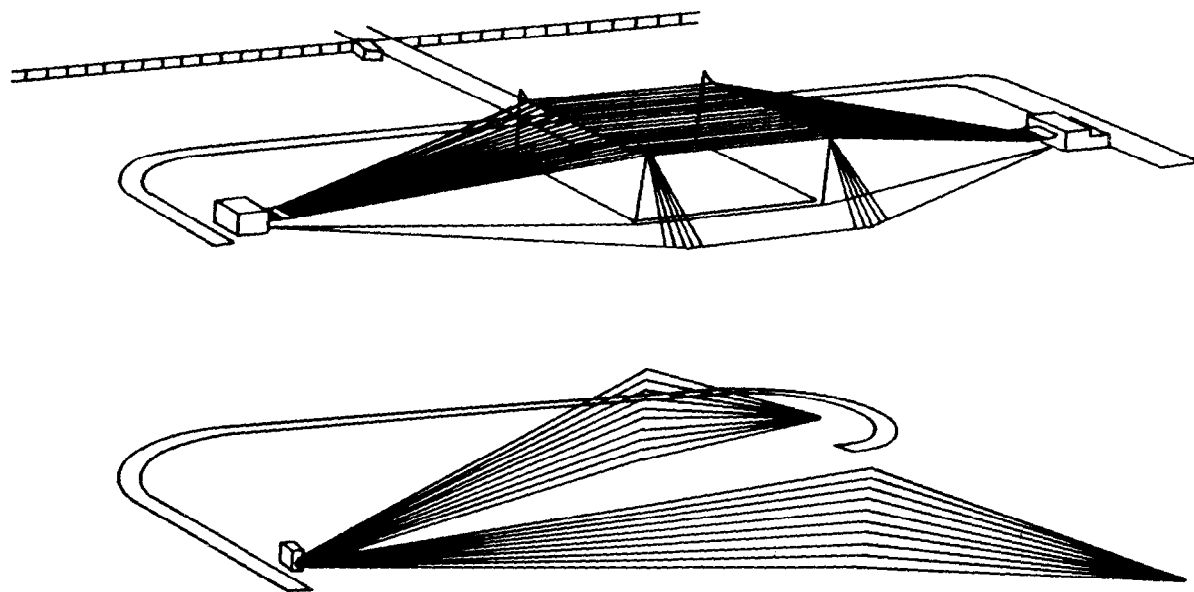


Figure 6-1. Bounded wave simulators.

EP 1110-3-2
31 Dec 90

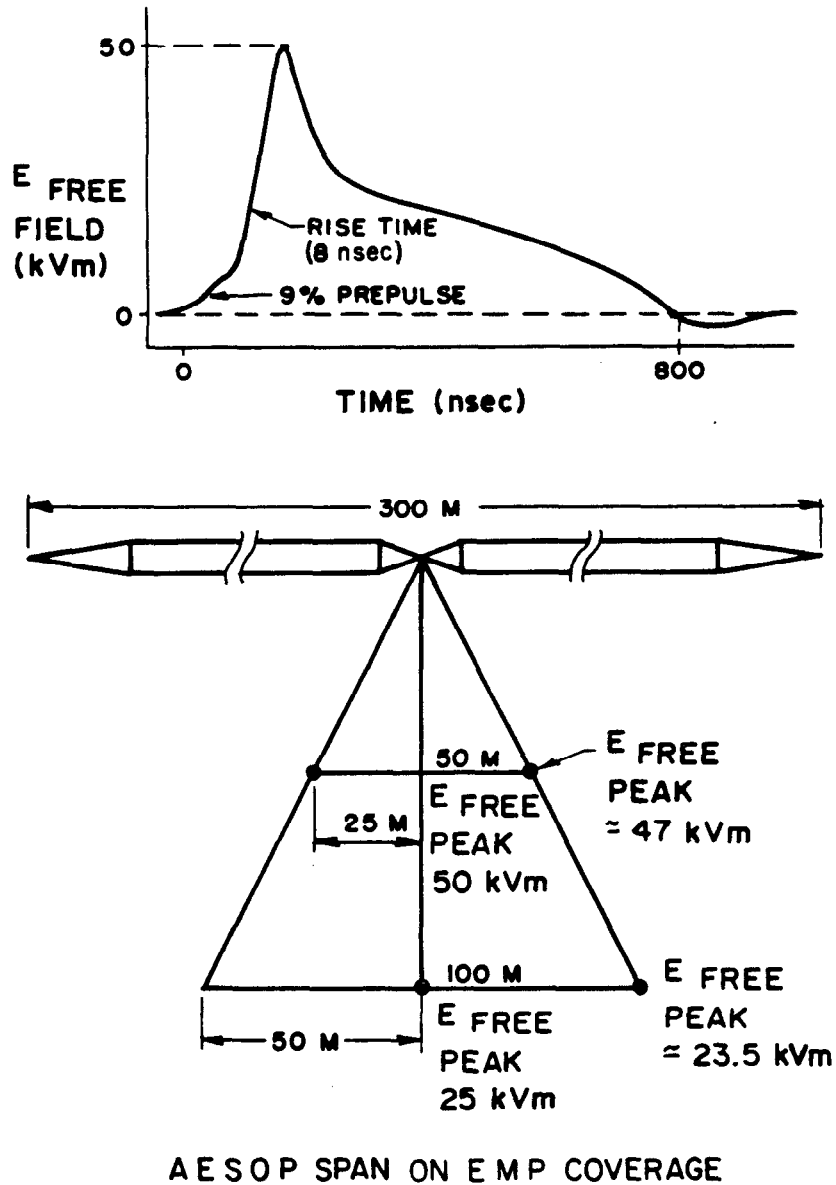
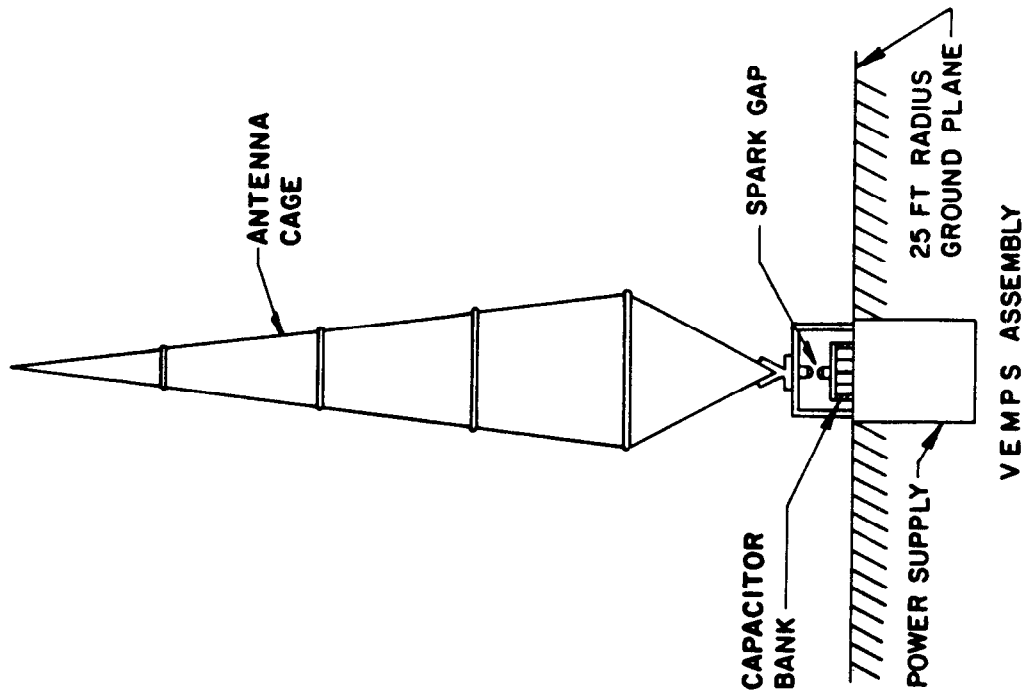


Figure 6-2. Pulsed radiated wave simulators. (sheet 1 of 2)



EP 1110-3-2
31 Dec 90

VEMPS CONSIST OF THE FOLLOW SUBSYSTEMS:

80-KV POWER SUPPLY

20-M -HIGH VERTICAL ANTENNA

UNDERGROUND POWER SUPPLY

GROUND PLANE

VEMPS ANTENNA PARAMETERS

OVERALL HEIGHT: 20 M.

LOWER CONE ANGLE: 56 DEGREES

UPPER CONE ANGLE: 14 DEGREES

MAXIMUM DIAMETER: 4 M

Figure 6-2. Pulsed radiated wave simulators. (sheet 2 of 2)

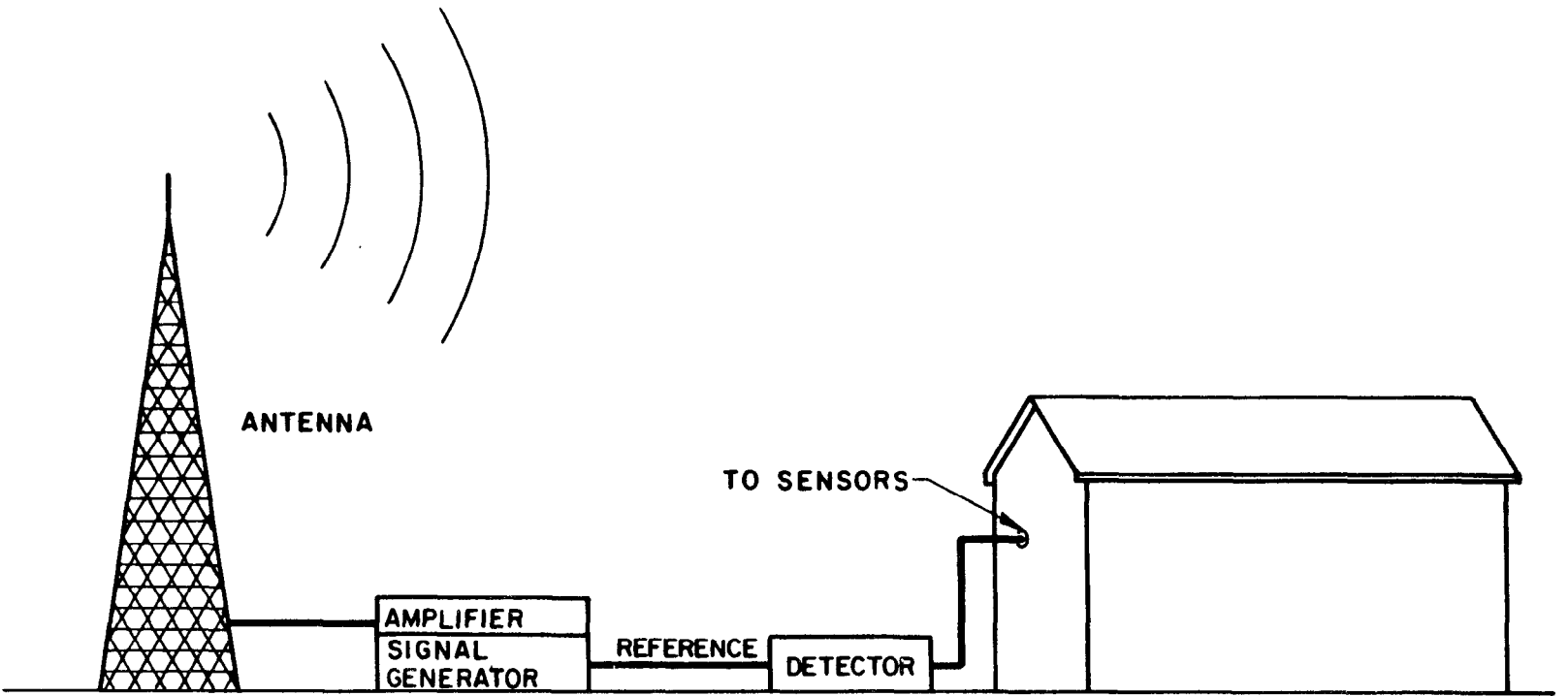


Figure 6-3. Continuous wave testing--CW test configuration.

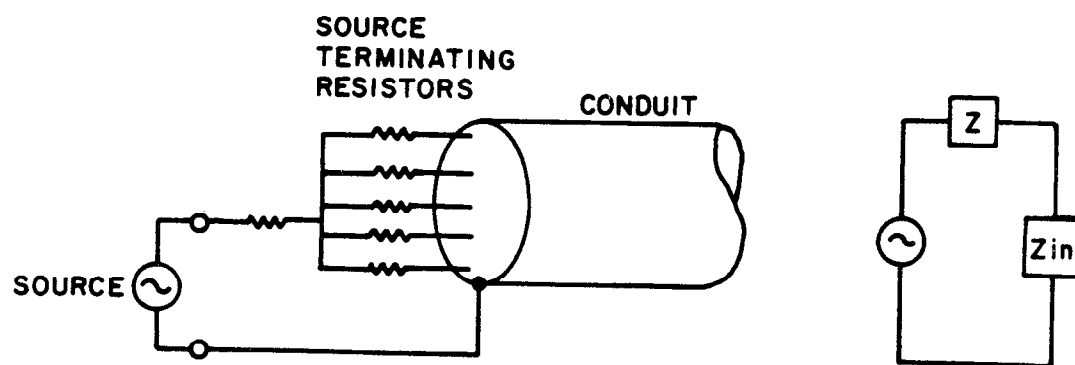


Figure 6-4. Direct current injection testing.

EP 1110-3-2
31 Dec 90

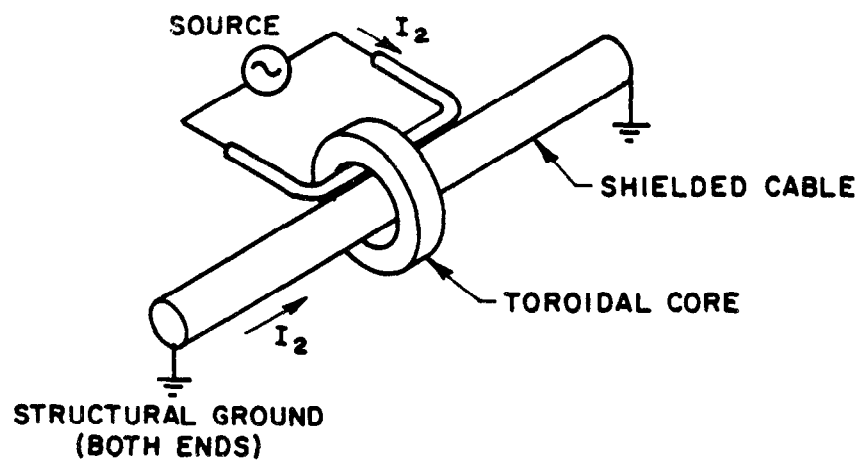


Figure 6-5. Inductive current injection testing.

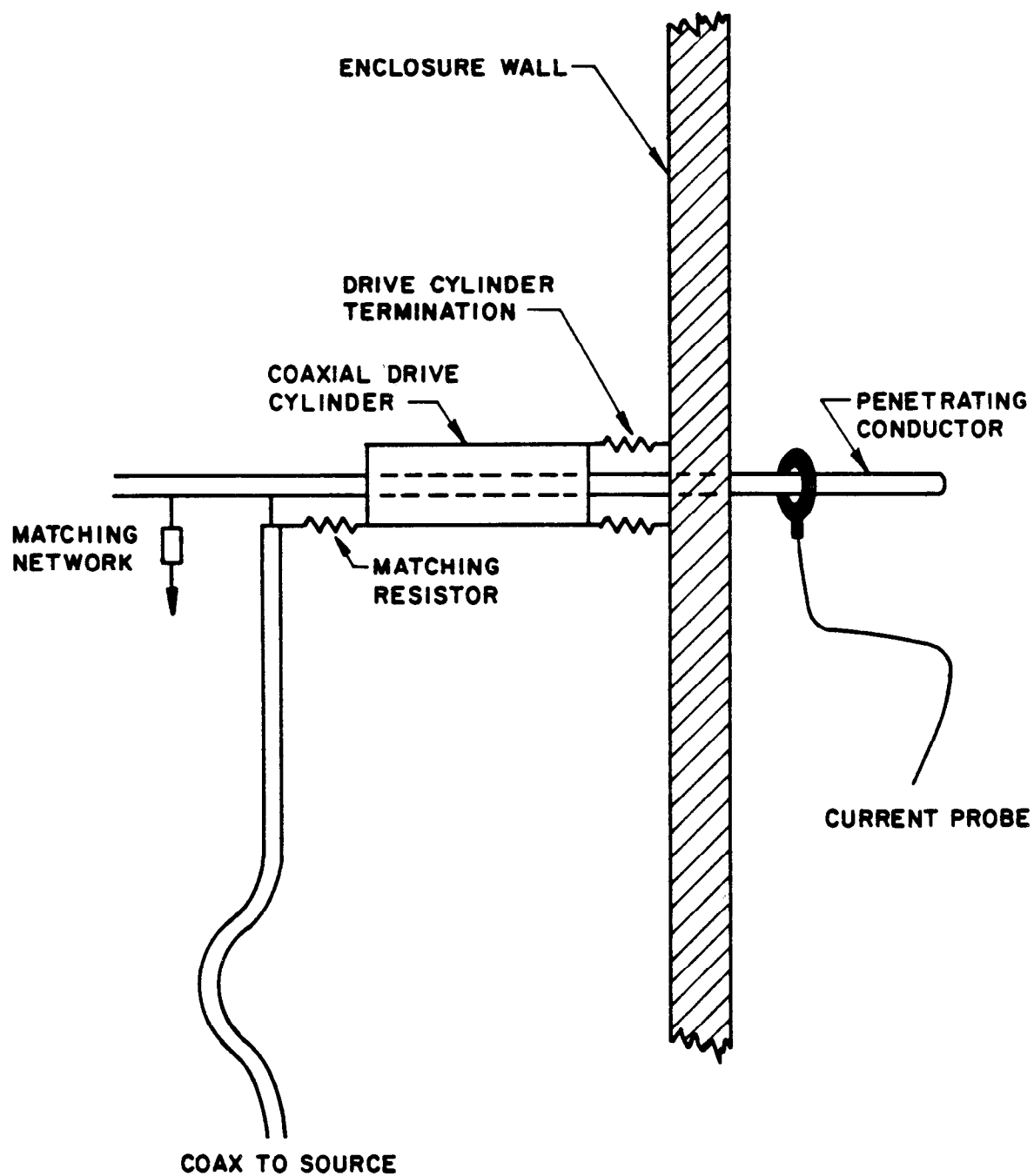


Figure 6-6. Direct drive test for penetrating conductor (conceptual sketch).

EP 1110-3-2
31 Dec 90

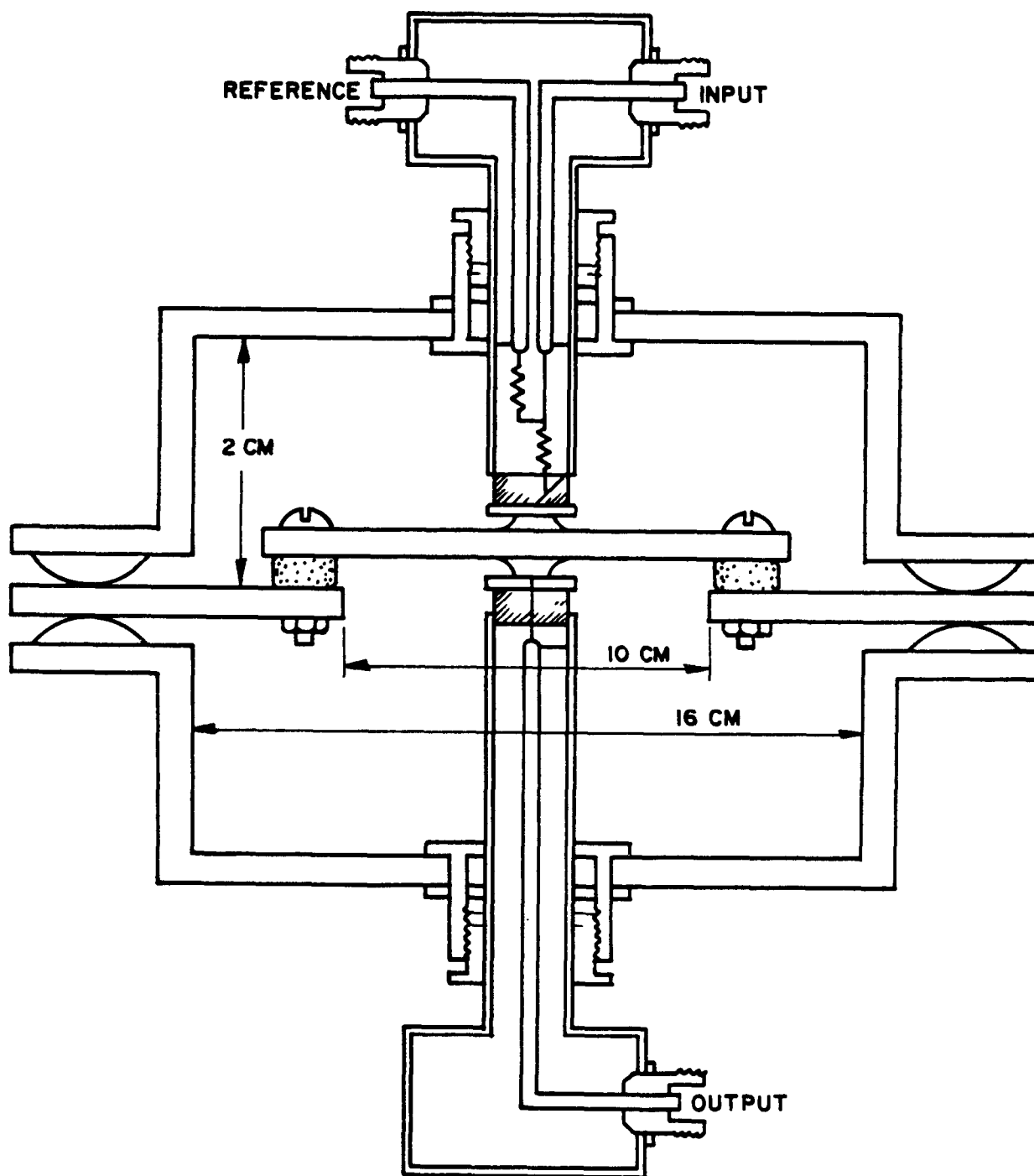
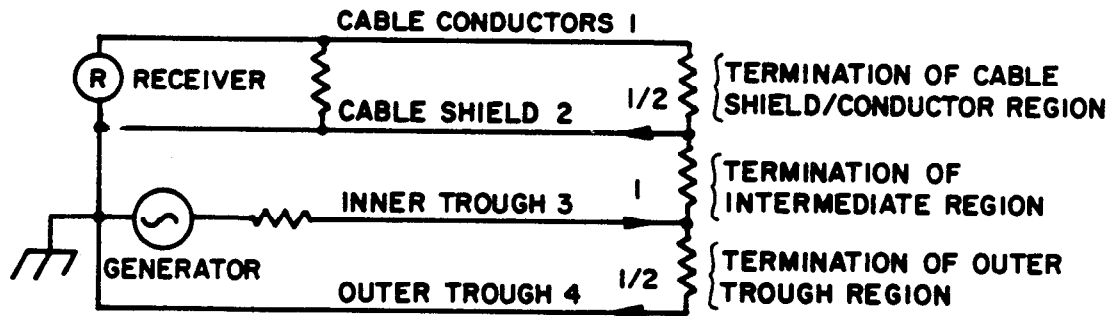
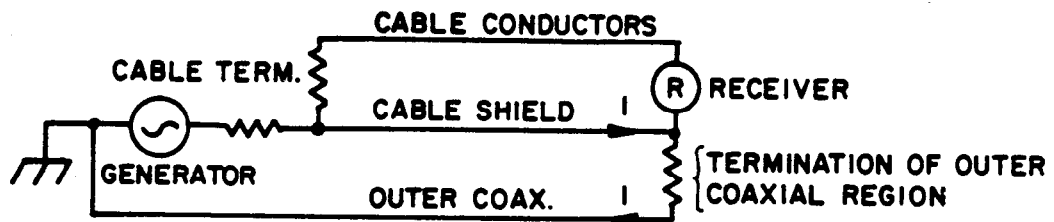


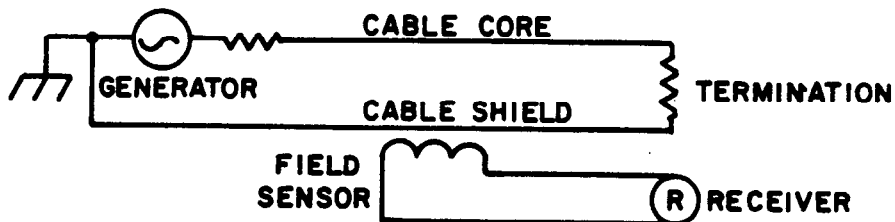
Figure 6-7. Transfer impedance/admittance test setup.



QUADRAXIAL TROUGH



TRIAxIAL ASSEMBLY



COAXIAL ASSEMBLY

Figure 6-8. Alternative demonstration and test methods.

EP 1110-3-2
31 Dec 90

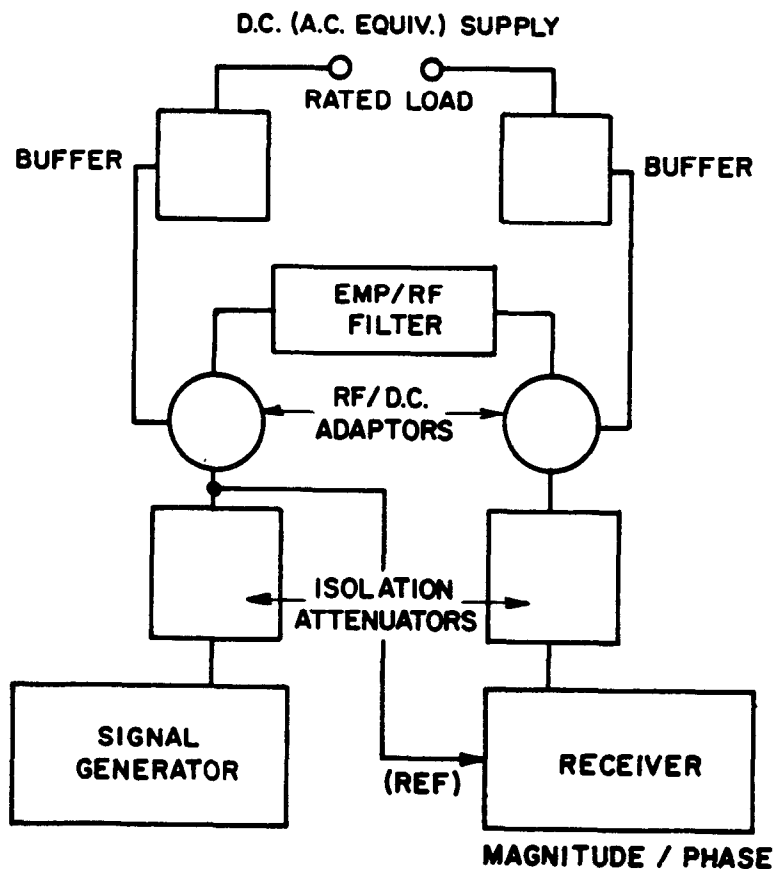


Figure 6-9. Response characteristic measurement.

FP 1110-3-2
31 Dec 90

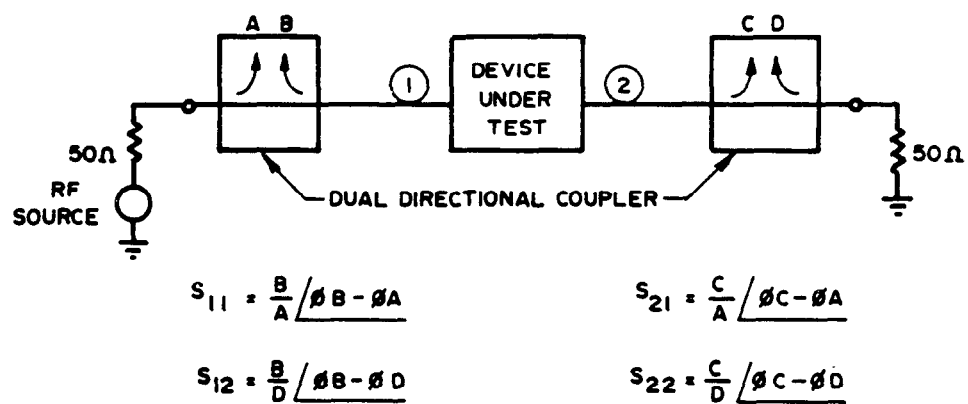


Figure 6-10. Standard circuit for measuring S parameters.

EP 1116-3-2
31 Dec 90

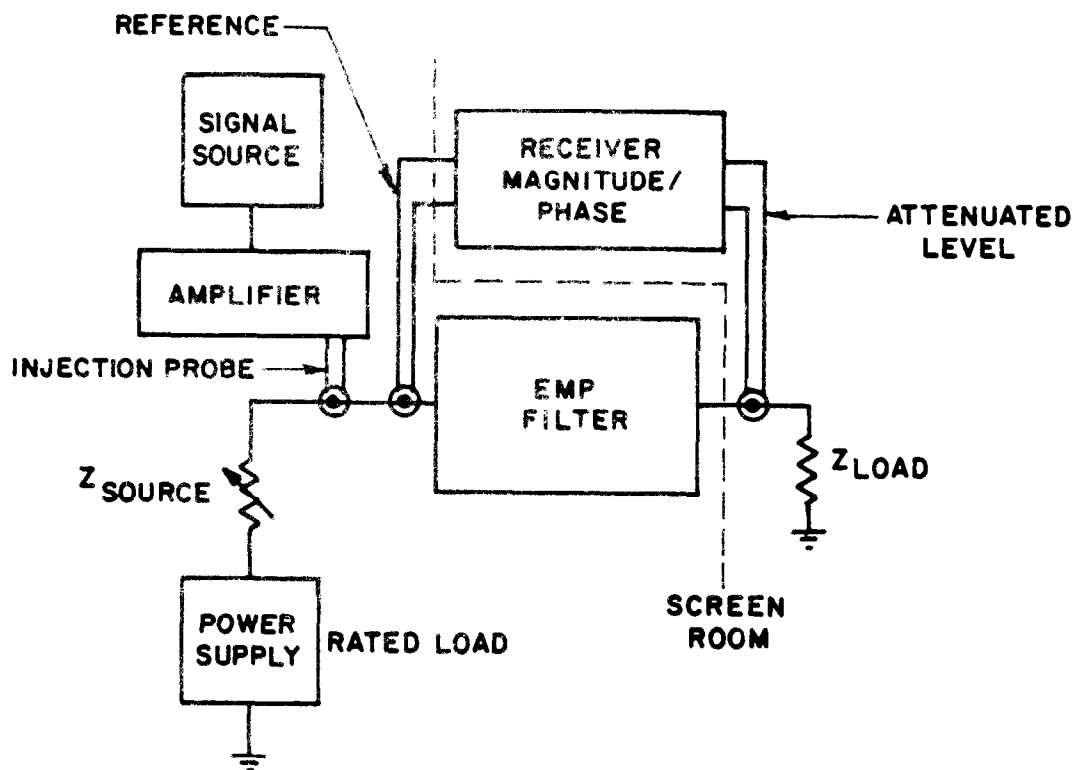


Figure 6-11. Response measurement. (Source: ref 6-4)

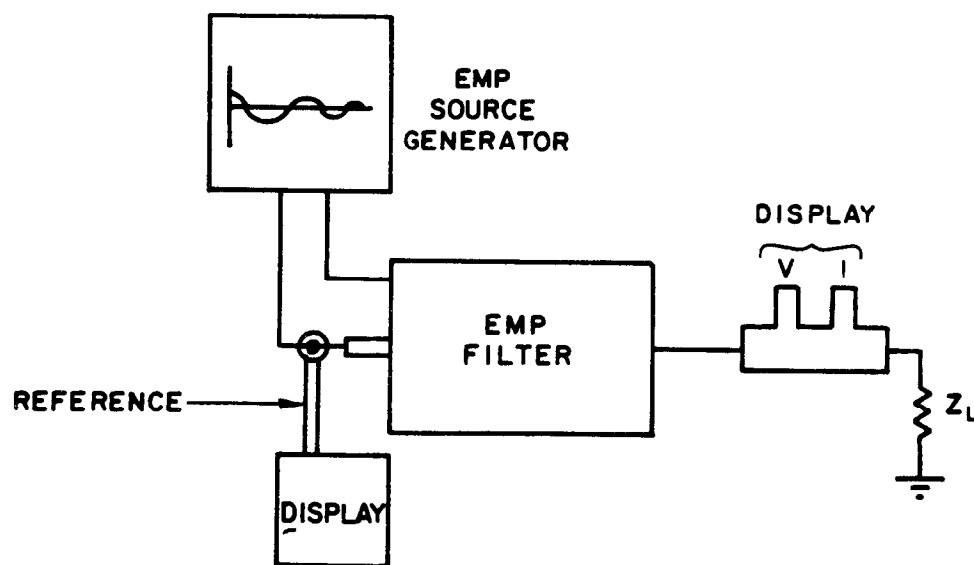
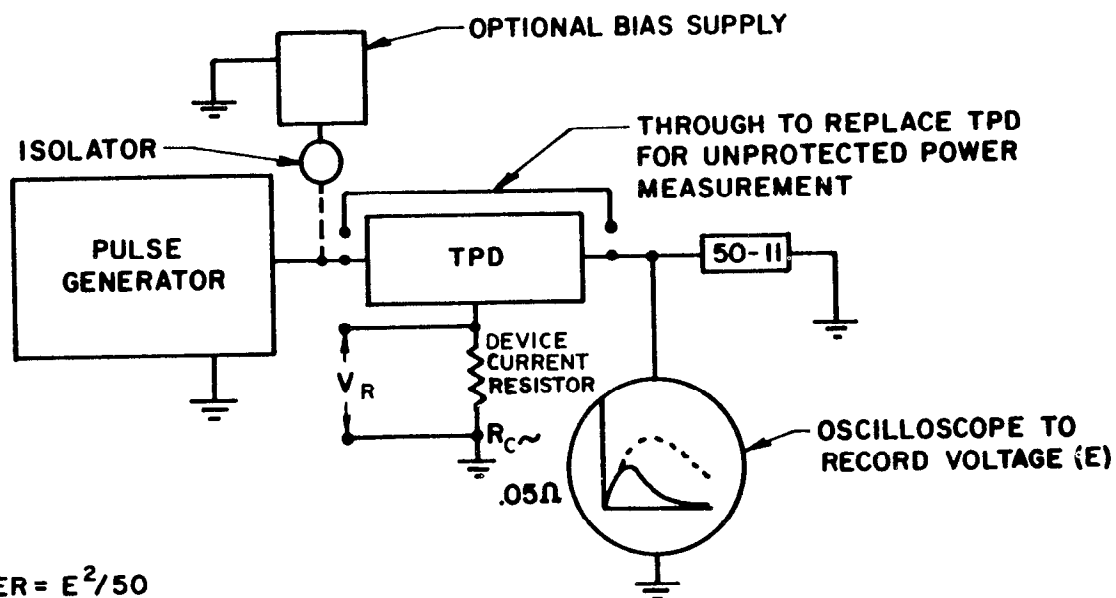


Figure 6-12. HEMP stress test. (Source: ref 6-4)

EP 1110-3-2
31 Dec 90



$$\text{POWER} = E^2/50$$

V_R USED TO DETERMINE TIME DENOTED AS t₁₀
WHEN DEVICE CURRENT ≈ 10 AMPS

$$\text{OPERATING IMPEDANCE} = Z_{10} - \frac{E(t_{10})}{10}$$

Figure 6-13. TPD power attenuation test. (Source: ref 6-4)

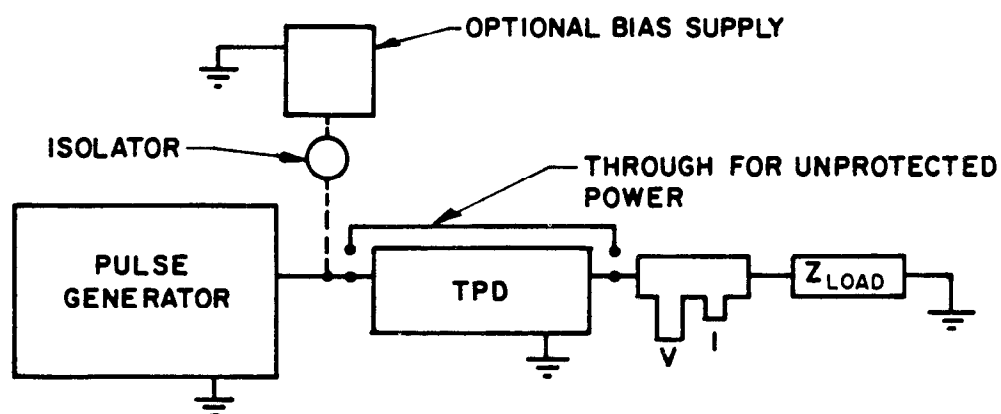


Figure 6-14. Alternative power attenuation test using simulated subsystem impedance. (Source: ref 6-4)

EP 1110-3-2
31 Dec 90

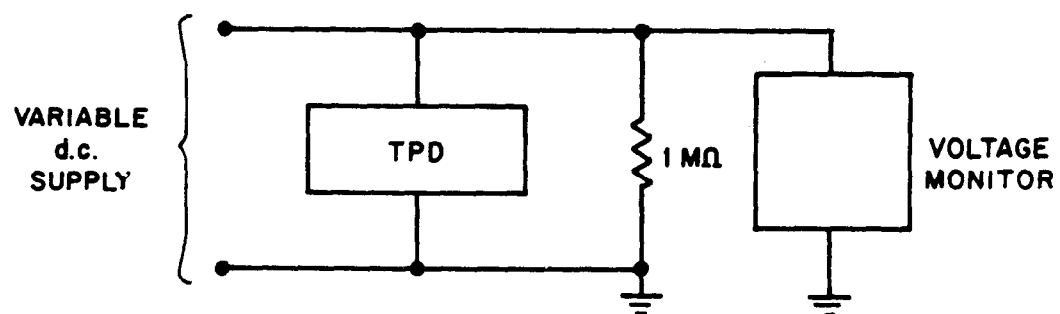


Figure 6-15. Static breakdown voltage measurement. (Source: ref 6-4)

SMALL LOOP-TO-SMALL LOOP COUPLING

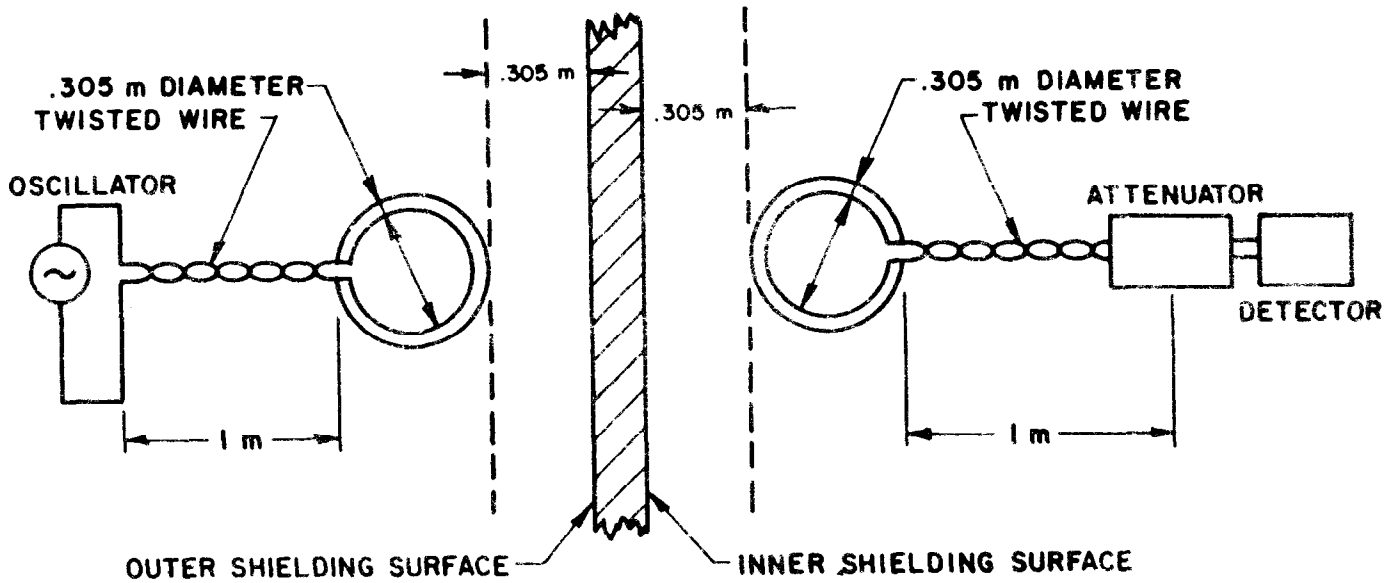


Figure 6-16. Small-loop-to-small-loop test setup. (Source: ref 6-4)

6-59

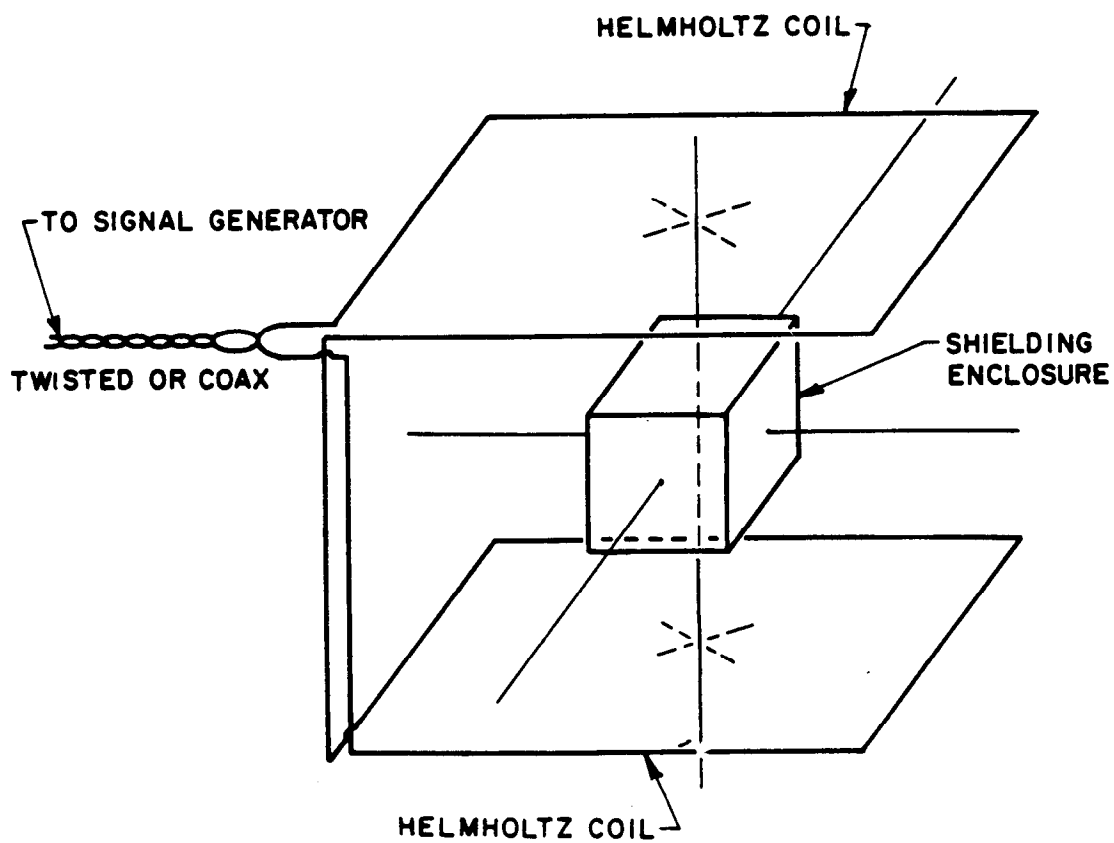


Figure 6-18. Test setup for Helmholtz coil field generation.
(Source: ref 6-4)

EP 1110-3-2
31 Dec 90

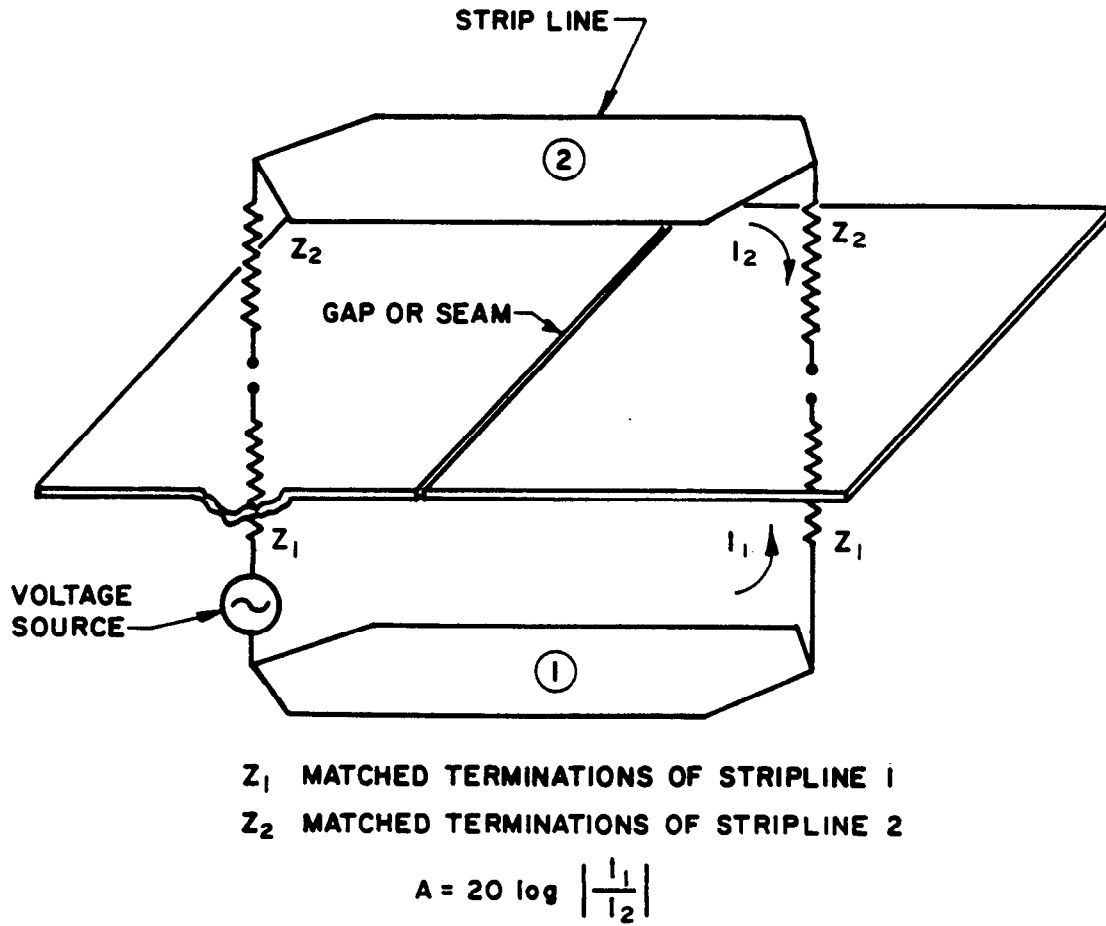
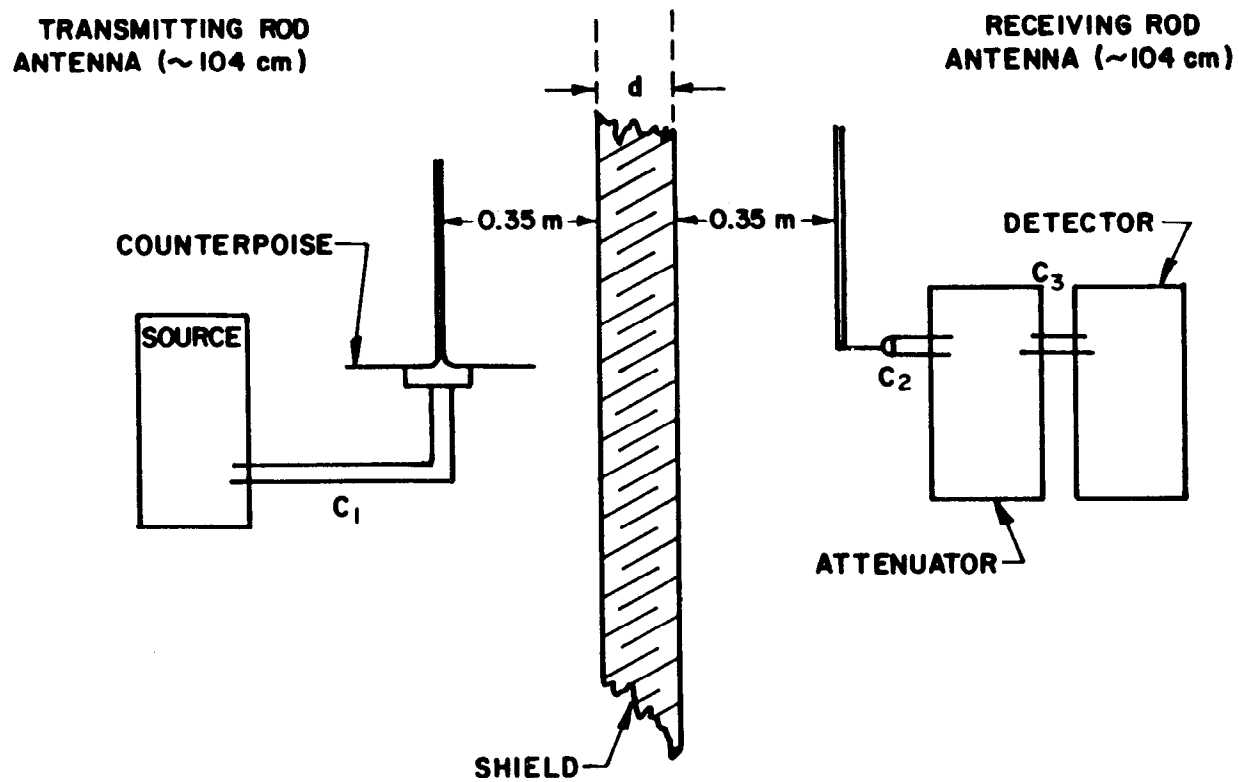


Figure 6-19. Parallel strip line technique. (Source: ref 6-4)

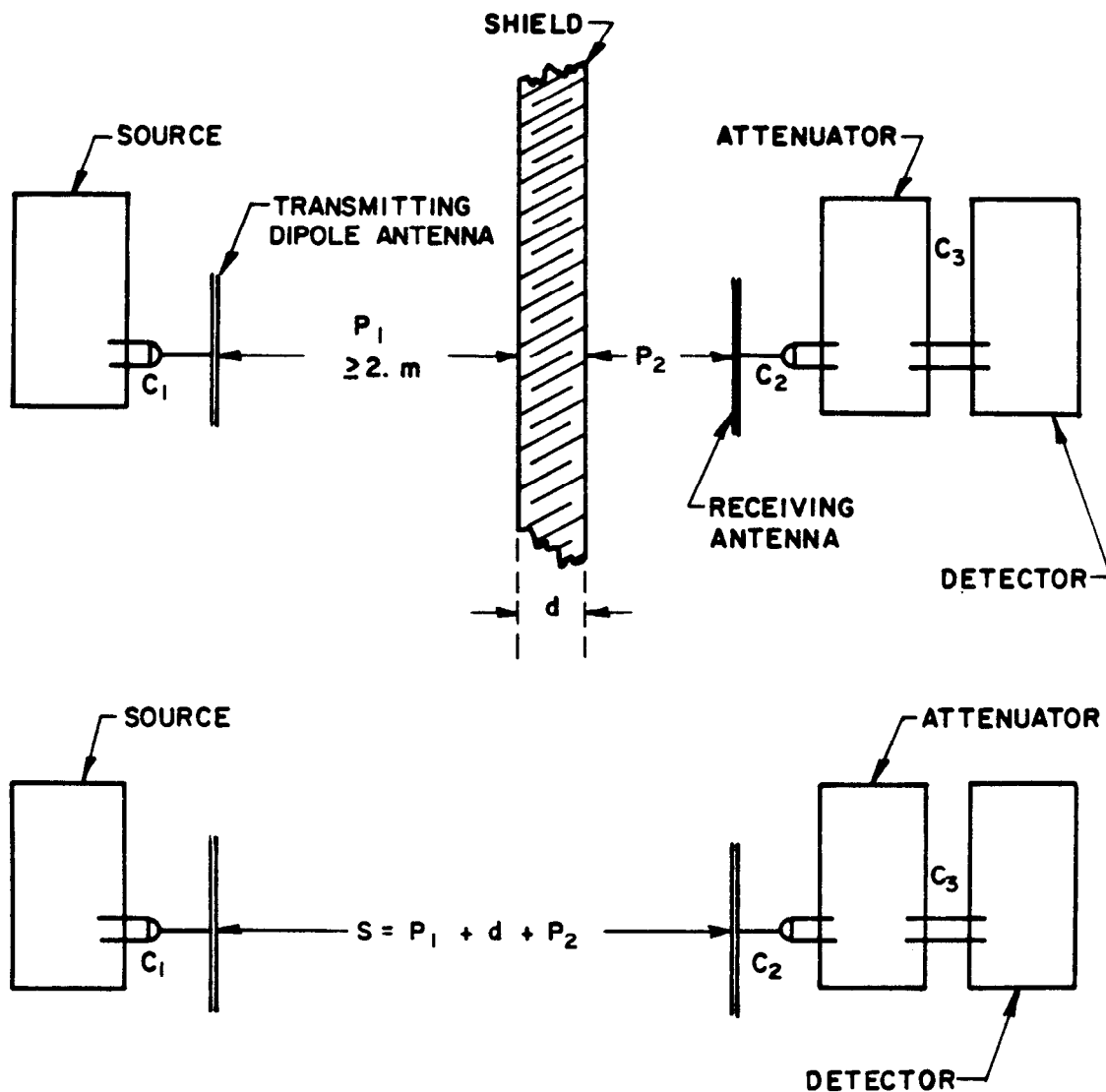
Figure 6-20. Attenuation measurement--high-impedance electric field.
(Source: ref 6-4)



C_1 , C_2 , C_3 ARE SHIELDED TRANSMISSION LINE CABLES KEPT SHORT AS POSSIBLE AND USED ONLY IF NECESSARY.

d IS THE SHIELD THICKNESS.

EP 1110-3-2
31 Dec 90



C_1, C_2, C_3 = shielded transmission line cables kept short as possible and used only if necessary.

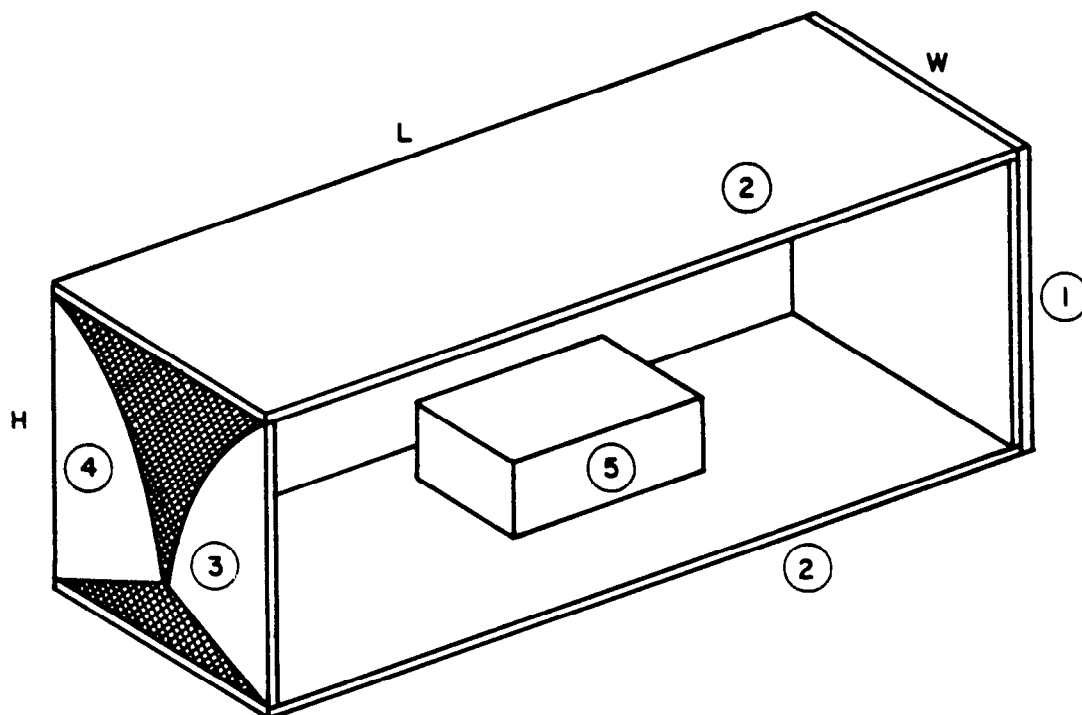
d = shield thickness

P_1 = position of transmitting antenna (2 m minimum). This distance shall be as great as possible, limited only by the power of the source.

P_2 = receiving antenna placed such that a maximum indication of the detector is obtained (5 cm minimum).

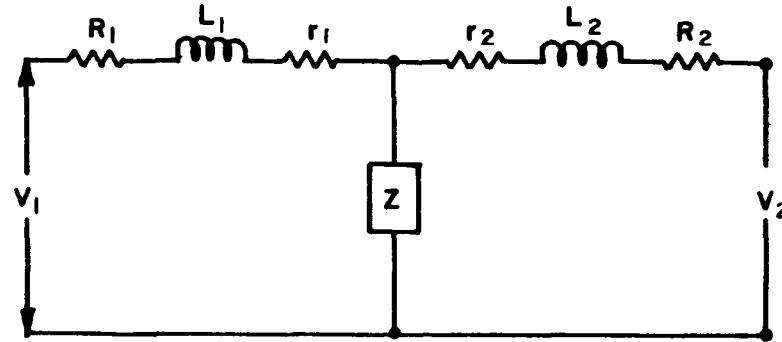
Figure 6-21. Attenuation test for plane waves (wave impedance = 377 ohms).
(Source: ref 6-4)

EP 1110-3-2
31 Dec 90



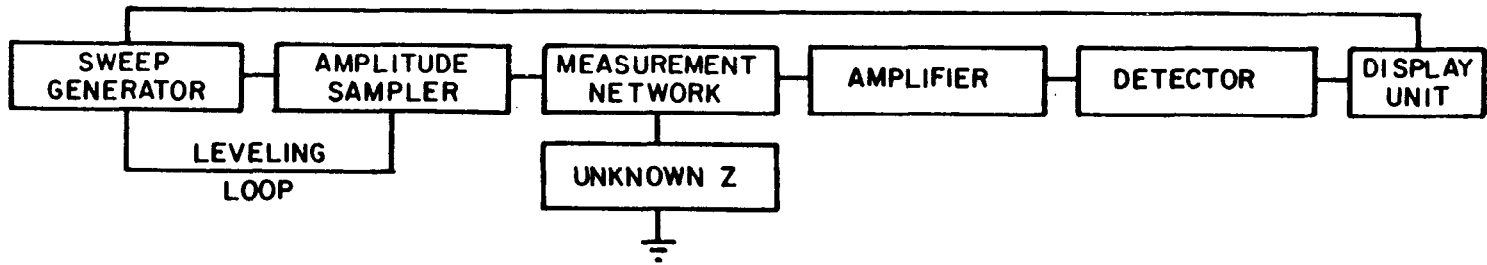
- ① Termination, separated layers of 377-ohm conductive plastic film, joined at ends and connected to conductive planes.
- ② Conductive planes, aluminum slotted longitudinally 1/2 in. o.c.
- ③ Input connector, BNC or N-Type.
- ④ Wave launcher, 1/16 in. copper on 1/2 in. plexiglass (~log curve).
- ⑤ Test enclosure.

Figure 6-22. Parallel plate line. (Source: ref 6-4)



Equivalent Circuit of Measuring Device

- R_1, R_2 = series isolation resistors
- r_1, r_2 = connection resistances
- L_1, L_2 = connection stray inductances
- Z = unknown bond impedance
- V_1 = input voltage
- V_2 = output voltage



Block Diagram of Sweep Frequency Measurement System

Figure 6-23. Sweep frequency bonding measurement system. (Source: ref 6-4)

CHAPTER 7

PROTECTION MAINTENANCE AND SURVEILLANCE

7-1. Outline. This chapter is organized as follows:

- 7-1. *Outline*
- 7-2. *Introduction*
- 7-3. *Facility life-cycle environment*
 - a. *Major environmental factors*
 - b. *Sources of degradation*
- 7-4. *Impact of hardness maintenance on facility design*
 - a. *Choice of shielding concept*
 - (1) *Tailored approach*
 - (2) *Global approach*
 - (3) *Tradeoffs*
 - (4) *Accommodating test and repair activities*
 - (5) *In situ tests*
 - b. *Test methods and equipment*
 - c. *Minimizing hardness maintenance requirements*
 - (1) *Level of shielding*
 - (2) *Terminal protection devices (TPD)*
 - (3) *Alternatives to hardwire*
 - (4) *Entry plate*
 - (5) *Example*
 - d. *Failure mode effect on hardness maintenance*
 - (1) *Typical failure modes*
 - (2) *Tradeoffs*
 - e. *Suitability of materials*
 - f. *Uncontrolled retrofits*
- 7-6. *Hardness maintenance program structure*
 - a. *Program elements*
 - b. *Interaction of program elements*
 - (1) *Preliminary planning*
 - (2) *Maintenance concepts*
 - (3) *Configuration management*
 - (4) *Parts control*
 - (5) *Maintenance procedures*
 - (6) *Training*
 - (7) *Documentation*
- 7-7. *Hardness surveillance (HS) activities*
 - a. *Inspections*
 - b. *Testing*
 - (1) *Classes of tests*
 - (2) *Built-in test features*
 - (3) *Using similar tests*
 - (4) *Pass/fail criteria*
 - (5) *Examples of specialized tests*

EP 1110-3-2
31 Dec 90

7-8. Cited references

7-2. Introduction. Facilities are protected against HEMP and TEMPEST through the numerous methods described in this EP. Generally, when construction is finished, acceptance tests and analyses are performed to assure that the facility meets the required hardness level and TEMPEST shielding before placing it into operation. Once the facility has become operational, it is necessary to assure its continuing HEMP hardness and communication security. To provide this assurance, some kind of hardness maintenance/hardness surveillance (HM/HS) and TEMPEST Shielding Maintenance (TSM) program is essential. The primary purpose of HM/HS/TSM is to detect any degradation of the protective measures incorporated into the facility and to take the necessary corrective action in a timely manner. Thus, an HM/HS/TSM program includes both preventive and corrective measures. This chapter describes such a program in terms of basic elements and possible variations.

7-3. Facility life cycle environment.

a. Major environmental factors. In operation, a HEMP-hardened and TEMPEST-protected facility will be subjected to environmental factors that will tend to degrade the hardness level. Major environmental factors are--

- (1) Weather-related conditions including lightning.
- (2) Soil chemicals and interactions.
- (3) Normal aging.
- (4) Exposure to miscellaneous contaminants.
- (5) Operator actions causing accidental damage.
- (6) Routine wear.
- (7) Abuse.
- (8) Changes in design configuration.
- (9) Abnormal electrical transients.
- (10) Changes in equipment used or operated in the facility.

b. Sources of degradation. Based on these factors, some of the most likely sources of hardness and shield effectiveness (SE) degradation may result from--

- (1) Door gasket corrosion.
- (2) Seam corrosion.

EP 1110-3-2
31 Dec 90

- (3) Door gasket contamination.
- (4) Deformation of door or other penetration gaskets.
- (5) Shield corrosion that produces openings.
- (6) Loss of proper grounding connection.
- (7) Shield degradation from penetrating retrofitted conductor installation.
- (8) Failure of surge arrester or filter components.
- (9) Cracks in welded seams.
- (10) Defects in disconnect switching.

7-4. Hardening shielding elements. The elements of a HEMP-hardened and TEMPEST-shielded (TS) facility to which HM/HS/TSM applies include--

- a. Shielded doors and hatches.
- b. All EMI and RFI gaskets.
- c. Blast doors.
- d. Air duct and ventilation filters.
- e. Electrical filters in power and communications lines.
- f. Shielded enclosures and zones.
- g. Lightning arresters.
- h. Electrical surge arresters.
- i. Grounding connectors.
- j. Electrical conduits, conduit fittings, junction boxes, and cable raceways.
- k. Flexible shielded connections.
- l. All shielded liner plate connections.
- m. Cathodic protection systems.

EP 1110-3-2

31 Dec 90

7-5. Impact of hardness maintenance on facility design. To be cost-effective and practical in meeting user requirements, HM/HS/TSM must be considered during the conceptual and detailed design phases of a facility. The choice of design can greatly impact HM/HS/TSM requirements. Further, operational constraints often dictate the HM/HS/TSM activity and can have major effect on the facility design.

a. Choice of shielding concept. One of the first considerations in facility design impacting HM/HS/TSM is the choice of shielding concept, that is, whether to use a tailored shielding approach or a global one.

(1) Tailored approach. The tailored approach, in which small-volume shields are applied to sensitive subsystems and/or equipment, is used primarily when the system elements are widely distributed. The various elements are individually shielded and interconnected via data links. These data links may be hard-wire cables which are shielded for HEMP and TEMPEST or they may be radiofrequency (RF) communications or fiber optics data links. The impact on HM/HS/TSM activities for each type of data link in a tailored system is described in c below.

(2) Global approach. In the global approach, one outer shield is designed to protect all TEMPEST and HEMP-susceptible systems located inside a structure. The global shielding approach minimizes the number of interfaces that require protection; this reduces HM/HS/TSM activities. The global concept also allows for future modification and expansion of the housed equipment since the facility shield provides all the required protection (isolation) from external fields. Some compartmentalization, or equipment-to-room size shields, may still be required for internally generated EMI and TEMPEST considerations.

(3) Tradeoffs. Figure 7-1 depicts possible tradeoffs when considering four hypothetical shielding concepts for a system in which two vans must communicate (a). The first option (b) shows a pseudo-global concept using very heavily shielded cable. The heavy cable shields represent shield extensions that eliminate induced transients on the cable conductors, thus eliminating the need for TPDs. The next two options (c and d) use lightly shielded cable with TPDs at both vans. Option (e) uses an RF communication link with no TPDs.

(4) Accommodating test and repair activities. Whatever shielding concept is chosen, it must accommodate the periodic HM/HS/TSM test and repair activities. For example, if a global shielding concept is used for an underground facility with the shield placed on the outside, shield performance will be very difficult to test. Inspection of the shield will be out of the question if the facility is direct-buried (that is, no free space exists between the structure and the earth). Moreover, testing with radiated fields is very complicated and the data are difficult to interpret. An alternative design would be to build test sources, exciters, and/or sensors into the

EP 1110-3-2
31 Dec 90

facility to obtain qualitative performance data on the shield and assess any degradation.

(5) In situ tests. The same considerations apply to room and even equipment shields. In determining if the SE of an equipment enclosure has degraded, tests must be conducted without disturbing the shield. This testing can be done by external illumination of the equipment shield and built-in pickup devices inside the shield. Shielded connectors (normally capped) and cables are then used to measure the pickup from inside the shield. The most common approach is to use external loops to generate the field and internal loops to measure internal pickup. This procedure does not give quantitative shielding effectiveness data, but is useful for comparison with baseline data. The internal pickup devices must be incorporated during the design and construction phases of the facility.

b. Test methods and equipment. In making provisions for HM/HS/TSM testing at the facility, the types of test procedures to be used and special test equipment requirements must be considered. These procedures and instruments must not degrade the protection element being tested (such as surge arresters) or the HS activity will be self-defeating. Further, if at all possible, they should have limited injection levels (voltage, current, or energy) such that if the protection element has failed, no damage occurs to the system itself. The specific techniques must be determined based on the protection levels required and the typical (common) failure modes of the device being evaluated. (See para d below.) Note that absolute performance to specification is not required for HM/HS/TSM activities; HM/HS/TSM testing is done to detect any changes from a baseline established at the time the facility was certification-tested.

c. Minimizing hardness maintenance requirements. Another aspect of HM/HS/TSM that must be considered during the design phase is to minimize the need for HM/HS/TSM activities. However, any steps to reduce these activities must be balanced carefully with the facility HEMP hardness and TEMPEST requirements.

(1) Level of shielding. If a facility uses a tailored shielding approach with hard-wire cables as data links, the level of cable shielding and system protection requirements will impact the HM/HS/TSM activity level. For example, if the cable SE is equal to that of the system element shields, a global shielding concept is achieved in principle. However, because of the distributed nature (size) of the shield systems, coupling to the HEMP field will be large and the SE must be increased accordingly. This means a higher level SE must be maintained which will require a much more complex HM/HS/TSM program.

(2) Terminal protection devices (TPD). If the data link SE is less than that of the system element shields or is not increased to account for the higher induced shield currents, terminal protection devices (TPDs) must be employed. These TPDs must be installed at each cable termination (where a

EP 1110-3-2

31 Dec 90

system element shield will be penetrated). This requirement greatly increases the number of TPDs that must be used, checked, and maintained.

(3) Alternatives to hardwire. Alternatives to hard-wire cable data links are RF communication links and fiber optic data links. These options are especially advantageous when a tailored shield concept must be used since they do not couple to the HEMP fields or prevent emanations. If, in the case of the RF links, the operating frequency is far removed from the highest EM frequency (by 400 megahertz or more), little or no terminal protection is required; thus, HM/HS/TSM activities are reduced. Optical links do not require TPDs, which also lowers the HM/HS/TSM requirements.

(4) Entry plate. If a global shield is used, only a single cable terminus (entry plate) must be considered since a single shield volume is being penetrated. As noted in paragraph a above, this design minimizes HM/HS/TSM requirements.

(5) Example. An example of a facility design with minimal HM/HS/TSM requirements is the North American Air Defense (NORAD) complex at Colorado Springs, CO. Because the facility is underground, high-frequency components of the incident HEMP field are greatly attenuated by the earth overburden. This design allows the use of waveguide-beyond-cutoff personnel doorways in the facility which are essentially maintenance-free compared with shielded doors that employ spring-finger contacts. These latter doors are highly susceptible to corrosion and damage if not designed properly with some form of mechanical protection. Sliding, pneumatic-type doors require far less maintenance than the spring-finger doors; however, the waveguide-beyond-cutoff doors used at this facility represent the lowest maintenance requirements of the three door types.

d. Failure mode effect on hardness maintenance.

(1) Typical failure modes. Catastrophic failure of protective elements may be evidenced as degradation of normal facility performance, depending on the failure mode of these elements. For example, semiconductor surge arresters normally fail short under catastrophic conditions. If they are used as shunt elements, such a failure will be evident by its effect on normal operations. Gas-gap-type surge arresters, on the other hand, usually fail open with time. These failures will not affect normal operations. Similar considerations apply to filters. If a shunt capacitor fails short, noticeable degradation will occur; if the capacitor fails open, the failure will not degrade normal facility performance.

(2) Tradeoffs. Thus, the failure mode of a device helps determine how often the device should be checked. If the failure of a device impacts (degrades) normal operation, HS/ TSM requirements will be lower than for devices without this potential effect. However, while devices that fail short are desirable in the sense of potentially reducing HS, they are not desirable from the aspect of overall system operational reliability. Thus, tradeoffs

EP 1110-3-2
31 Dec 90

will have to be made during the design phase when the protection concept and protection devices are being selected. Table 7-1 provides examples of some tradeoff elements with qualitative comparisons.

e. Suitability of materials. Attention must be given to the materials comprising protective devices and features to ensure long-term performance in the facility environment. Items such as RFI filter covers, RFI gaskets, and grounding hardware are available in a variety of materials with different degrees of resistance to corrosion, structural deformation, and other stresses. Some shielding materials can be coated with special paints to give them more corrosion resistance. Surfaces to be mated with RFI gaskets, however, must not be painted. RFI door jambs are generally plated with tin to impart nonoxidizing, high-conductivity contact between the fingerstock gasket on the door and the shielded enclosure. Dissimilar metals used at electrical contacts often conflict with ideal corrosion control. However, tin-plated gaskets are compatible with a large number of other materials.

f. Uncontrolled retrofits. Once a facility has been hardened against HEMP and TEMPEST, the protection can be compromised easily by uncontrolled retrofits and modifications. The most typical example of an uncontrolled retrofit is the routing of cables through the shield at points other than the normal vault area with terminal protection. This is often done with a simple hole drilled through the shield. Modifications that compromise the SE must not be allowed. The effect of all modifications on HEMP hardness and TEMPEST protection must be analyzed carefully to ensure the protective system's integrity.

7-6. Hardness maintenance program structure.

a. Program elements. The major elements of an HM/HS/TSM program include--

- (1) Preliminary planning.
- (2) Concept development.
- (3) Configuration management.
- (4) Parts and circuit control.
- (5) Maintenance procedures.
- (6) Training.
- (7) Documentation.

b. Interaction of program elements. Figure 7-2 shows how these program elements interact.

EP 1110-3-2
31 Dec 90

(1) Preliminary planning. Ideally, the HM/HS/TSM program should be developed concurrent with development of requirements, criteria, and design plans and to specifications of the facility itself. Since life-cycle hardness requirements can have major impact on the overall facility design, a properly developed HM/HS/TSM plan can reduce facility life cycle costs.

(2) Maintenance concepts. Concurrent with facility design concept development, specific HM/HS/TSM concepts should be developed based on sound technical requirements and realistic test and inspection activities. It must be possible to implement these concepts on-site taking into account the system to be protected, its potential disruptions, and available maintenance personnel.

(3) Configuration management. During a HEMP-hardened/TEMPEST-protected facility life cycle, the configuration of mission-critical systems may be changed. These changes may affect the HEMP hardness or TEMPEST protection. Thus, every engineering change proposal (ECP) should be reviewed to evaluate its potential impact on hardness. The reviewers must have enough HEMP and TEMPEST expertise for proper evaluation. Depending on the facility size, function, criticality, and the major command using the facility, various types of configuration management programs can be used. Figure 7-3 shows a typical program.

(4) Parts control. A system developer uses parts control to influence future decisions on parts procurement toward preserving HEMP hardness and TEMPEST protection. Decisions that can be important include those for obvious hardness and TEMPEST protective items, such as transient suppressors, gaskets, cable shields, and other sensitive equipment. Detailed specifications are required for these items so that proper parts can be selected based on the manufacturer's specifications and on product performance testing. The design for interfacing pieceparts and subsystems also must be specified properly when overall system hardness or SE depends on the inherent survivability or hardening of these parts. An example would be a system with an electronics module that requires no hardening because it has a damage threshold exceeding the HEMP threat waveform by more than the specified margin. The system survivability depends on the module's ability to withstand induced threat-level transient pulses. Therefore, parts procurers at some later date will need guidance in selecting components of comparable hardness that will be compatible with the system.

(5) Maintenance procedures. A well defined set of maintenance procedures specifically tailored to each HEMP-hardened and TEMPEST-protected facility is a major part of the successful HM/HS/TSM program. From the HEMP hardening/TEMPEST protection standpoint, maintenance procedures include all measures that must be taken to prevent degradation of the facility HEMP hardness/TEMPEST protection level. The corrective measures for specific hardening elements should be determined by studying the potential deterioration mechanisms to which the element is subjected. Maintenance events have four major purposes:

EP 1110-3-2
31 Dec 90

- Preventing hardness and TEMPEST deterioration to the extent necessary. Preventive maintenance in HEMP-hardened and TEMPEST-protected facilities may involve replacing RFI gaskets, applying cleaners and lubricants to gaskets, cleaning door surfaces that mate with gaskets, dismantling and cleaning seams of demountable shielded enclosures, replacing gaskets in equipment cabinets, replating critical surfaces by brush-electroplating, cleaning air-duct filters, and replacing RFI tape when necessary.
- Determining if any deterioration mechanism detected has acted on the protective element such that HEMP/TEMPEST protection is jeopardized. Deteriorated conditions can be detected by testing or by inspections as discussed in paragraph 7-6.
- Doing corrective maintenance to repair, replace, or refurbish elements found defective. Corrective maintenance includes replacement of any shielding element found defective during inspection or test. It may involve completely replacing the element, patching shields, replacing electrical filters, replacing gaskets, and other such actions.
- Verifying the adequacy of repair. This requires inspection, testing or both.

(a) The maximum allowable time interval between maintenance events is based on the environment, susceptibility of the protective element, severity of element usage, wear, and all other factors related to degradation. These factors include the item's location, nearness to personnel traffic, and number of operational cycles per given time period; the life expectancy of protective items; and on-site experience with installed equipment.

(b) Failure criteria must be developed to provide maintenance personnel with information they will need to determine if critical hardware items have deteriorated below acceptable levels. The failure criteria must be stated in measurable go-no go quantitative units that do not require qualitative judgment for deciding if an item is acceptable. For inspection, meaningful quantitative criteria may be difficult to define. Examples would include minimum torque values for bolted connections and maximum misalignment of the door with the frame. For testing, criteria may include minimum RF attenuation values and maximum resistance across ground connections.

(c) HM/TSM events should be a part of regular maintenance for the facility. HM/TSM data and instructions can be included with the regular maintenance data and instructions. The integration of HM/TSM with regular facility maintenance optimizes overall maintenance efficiency. Figure 7-4 shows an example of a specific system and associated maintenance procedures.

EP 1110-3-2
31 Dec 90

(6) Training. Operating personnel must have a general understanding of what HEMP is, how its effects can be reduced, and what TEMPEST is and how to prevent compromise. Operators and maintenance persons for HEMP-hardened and TEMPEST-protected systems need a general knowledge of HEMP and TEMPEST effects as well as specific knowledge of the HEMP and TEMPEST protective features for the systems on which they work. Facility managers must know all these things in addition to program, schedule, and cost effects of HEMP hardening and TEMPEST protection.

(a) Training goals for O&M persons at HEMP-hardened and TEMPEST protected facilities include: identifying items critical to system hardness and TEMPEST protection; learning system hardness philosophy; learning TEMPEST regulations and procedures; developing proficiency in all maintenance procedures; developing skills in hardness and SE testing; becoming familiar with documentation and manuals; and learning to interpret test results.

(b) Achieving these goals will ensure that the O&M staff does not inadvertently degrade the built-in HEMP/TEMPEST protection. Further, it will enable greater efficiency in time spent by test and inspection personnel, improving the probability of overall mission success for the facility.

(c) There are several resources for training test and inspection personnel (ref 7-2). For example, these individuals might attend DNA- or NSA-sponsored courses (joint staff, service agencies, NATO) for test and inspection of HEMP hardening and TEMPEST protection. Another possibility is that the facility develop site-specific training materials for its personnel. In addition, personnel may acquire HEMP and TEMPEST expertise in industry and Government labs under special training programs.

(7) Documentation. The success of a life-cycle HM/HS/TSM program depends heavily on the documentation compiled to support hardness assurance, maintenance, and surveillance.

(a) System configuration management is largely based on the documentation identifying items critical to hardness or TEMPEST protection. This information clearly defines the baseline to be managed. The baseline is focused on elements that comprise the system hardening mechanism. Information on the hardening/TEMPEST protection design also supports O&M, and, indirectly, training and surveillance testing. Specifications for system components support these activities as well.

(b) The HM/HS/TSM plan defines which measures must be taken to ensure the system's hardness/tempest protection throughout its life. Measures taken during initial hardness validation and those scheduled for after the system is operational must not comprise the plan.

7-7. Hardness surveillance (HS) activities. HS consists of activities for monitoring a facility's continued hardness to HEMP events, and TSM consists of activities for monitoring and controlling a facility's compromising

EP 1110-3-2
31 Dec 90

emanations. The primary activities of HS/TSM are inspection and testing. Inspection, testing, or both will be required on a periodic basis to ensure the system's continued hardness and SE or to verify the adequacy of a repair. The procedures to follow in these inspections and tests must be developed on a system-specific and facility-specific basis. Further, as maintenance experience is gained, it may become apparent that changes in procedures are necessary. In addition, if retrofits or repairs are made, specific inspection and test procedures should be designed to validate the resulting hardness and SE.

a. Inspections. For some protective elements, visual inspection can reveal deterioration or damage. Inspectors should be trained to perform visual inspections. This training should provide knowledge of the protective elements' hardening and TEMPEST protection function, including what the normal acceptable condition is. Examples of visual inspections derived from the SAFEGUARD protection integrity maintenance (PIM) plan are (ref 7-1)--

- (1) Inspect shielded doors and hatches for gasket cleanliness and condition.
- (2) Inspect air-duct filters for cleanliness, integrity, and proper bonding or gasketing to mating surfaces.
- (3) Inspect power-line or communications-line filters for properly gasketed covers and for evidence of leakage from sealed components.
- (4) Inspect grounding circuits and straps for proper condition.
- (5) Inspect transformers for leakage or other damage.
- (6) Inspect sealed conduit systems and components for excessive corrosion.
- (7) Inspect flexible conduits for corrosion.
- (8) Inspect shield seams for evidence of corrosion, cracks, and other damage.
- (9) Inspect cathodic protection systems for deterioration.
- (10) Inspect shielded cable trays for damage or corrosion.
- (11) Inspect piping, traps, sinks, and drains for proper seams.

b. Testing. The starting point for HS/TEMPEST shielding (TS) testing, as with all post-acceptance HM/HS/TSM activities, is hardening and TEMPEST protection acceptance documentation. This documentation specifically defines what to test, when to test, and how to test to ensure that the system stays hard, despite the effects of wear and corrosion. Surveillance testing is

EP 1110-3-2
31 Dec 90

based on the survivability analysis, hardening, and SE approach taken to protect the system against HEMP effects and TEMPEST compromise. The test program focuses on the features essential to hardness and SE, such as shielding, transient suppressors, and critical parts. Potential effects that could damage system hardness and SE are also considered. Items likely to degrade such as gaskets, are tested if the degradation would compromise hardness and SE. In some cases, particularly when erosion is a concern, testing must be done at regular intervals. Other tests are event-specified; for example, "after a thunderstorm" might be suitable for checking possible lightning damage to HEMP-hardened equipment. The documented procedures identify the test equipment to be used and provide guidance on performing the test.

(1) Classes of tests. The tests used will generally be of the types described in chapter 6 of this EP. The general classes of tests include--

- (a) Some form of electromagnetic illumination.
- (b) Seam leak detection.
- (c) Special methods for filters and surge arresters.

(2) Built-in test features. Some facilities are designed with built-in features for hardness assurance tests. One such approach is to use three orthogonal loops or coils around the entire facility. These loops are excited at a fixed frequency and field levels are measured at specified points inside the shielded zone. Usually, an initial set of data is obtained during facility acceptance testing. Retest data can then be compared with original data for evidence of deterioration.

(3) Using similar tests. The best type of test program would use similar equipment and methods for both initial acceptance and life-cycle hardness testing.

(4) Pass/fail criteria. Simple pass/fail criteria should include instructions to guide operating personnel in what actions to take next should the test indicate failure. Additional testing may be needed to define how serious the failure is. Another response may be to repair or replace an item.

(5) Examples of specialized tests. In many cases, specialized tests are applicable to various system components or evaluation procedures. Some examples are listed below.

(a) A specialized test method called PLACER was developed for the SAFEGUARD system to test buried conduits. This example shows the need to consider maintenance in the research, development, test, and evaluation (RDT&E) or system design hardening process to ensure successful maintenance.

EP 1110-3-2
31 Dec 90

(b) The SAFEGUARD ABM maintenance testing program included electromagnetic illumination tests at only two discrete frequencies to evaluate the SE of doors, shield membranes, seams, and shield penetrations. These hardness critical items (HCIs) were tested at 200 kilohertz using loop antennas and at 3 gigahertz using horn antennas. Data were compared with acceptance test data to show deterioration trends.

(c) Power line filters are examples of items that require specially designed test techniques. Often the test must be nondisruptive and therefore done with power flowing through the filters. It is essential that engineering personnel with HEMP and TEMPEST expertise have input into the HS/TSM test plan.

7-8. Cited references.

- 7-1. Program Plan, Protection Integrity Maintenance (PIM) for SAFEGUARD Facilities, Vol 2, HNDSP-73-NO-ED-R (U.S. Army Corps of Engineers, Huntsville Division, December 1973).
- 7-2. EMP Course Study Guide (Defense Nuclear Agency, April 1983).

EP 1110-3-2
31 Dec 90

Table 7-1. Qualitative tradeoff study results

Criteria	Design Comparison		
	Intersection-welded rebars	Small volume critical area shield	Envelope shield
Cost analysis	Costly	Costly	Least costly
Performance estimate	Unpredictable	Reasonably predictable	Reasonably predictable
Future needs	Permits expansion	Expansion costly	Permits expansion
Satisfactory	Difficult	Satisfactory	Maintenance
Maintenance	Satisfactory	Difficult	Satisfactory
Grounding and cabling plan	Satisfactory	More difficult	Satisfactory

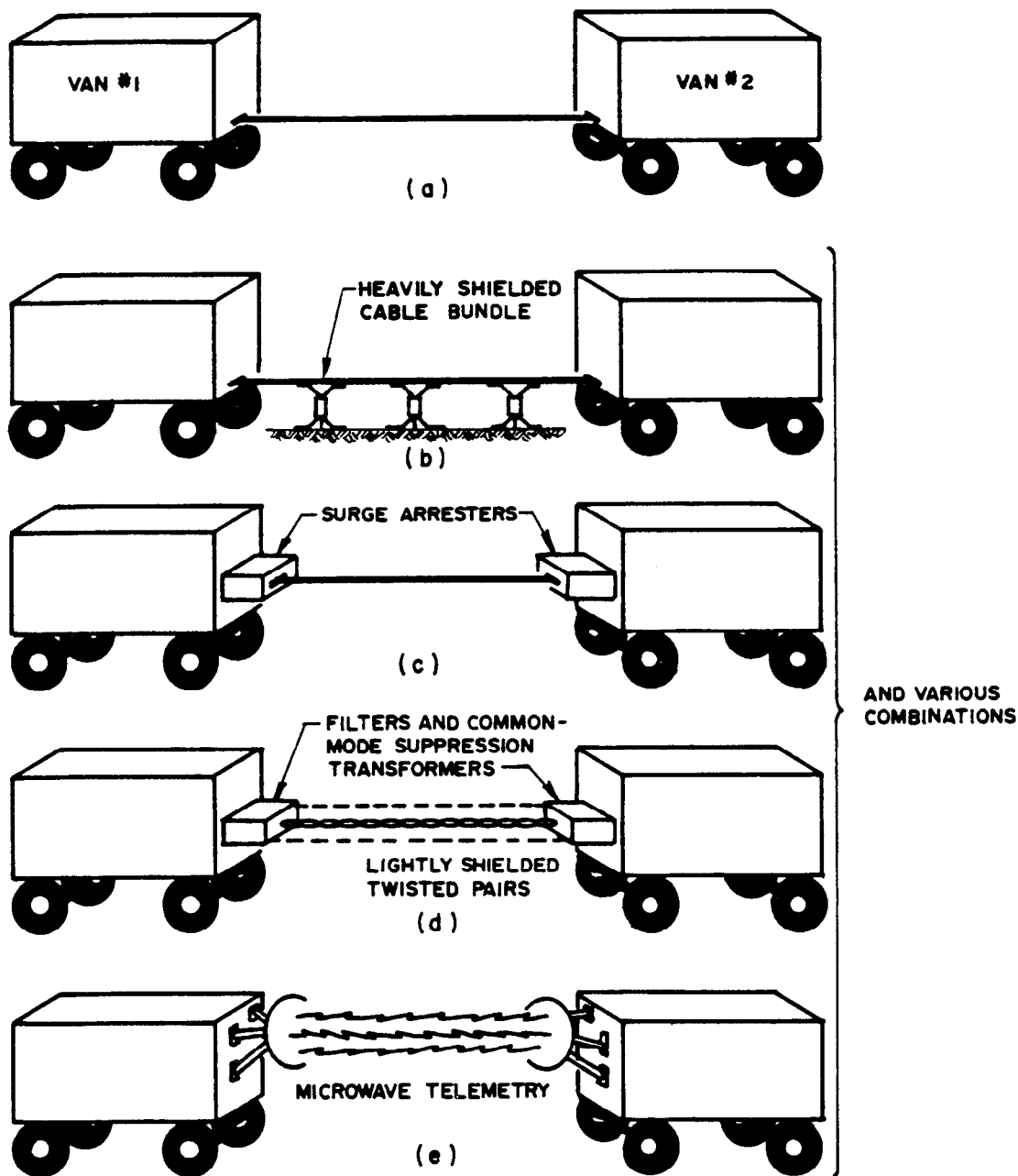


Figure 7-1. Effect of hardening approach on subsystem design.

EP 1110-3-2
31 Dec 90

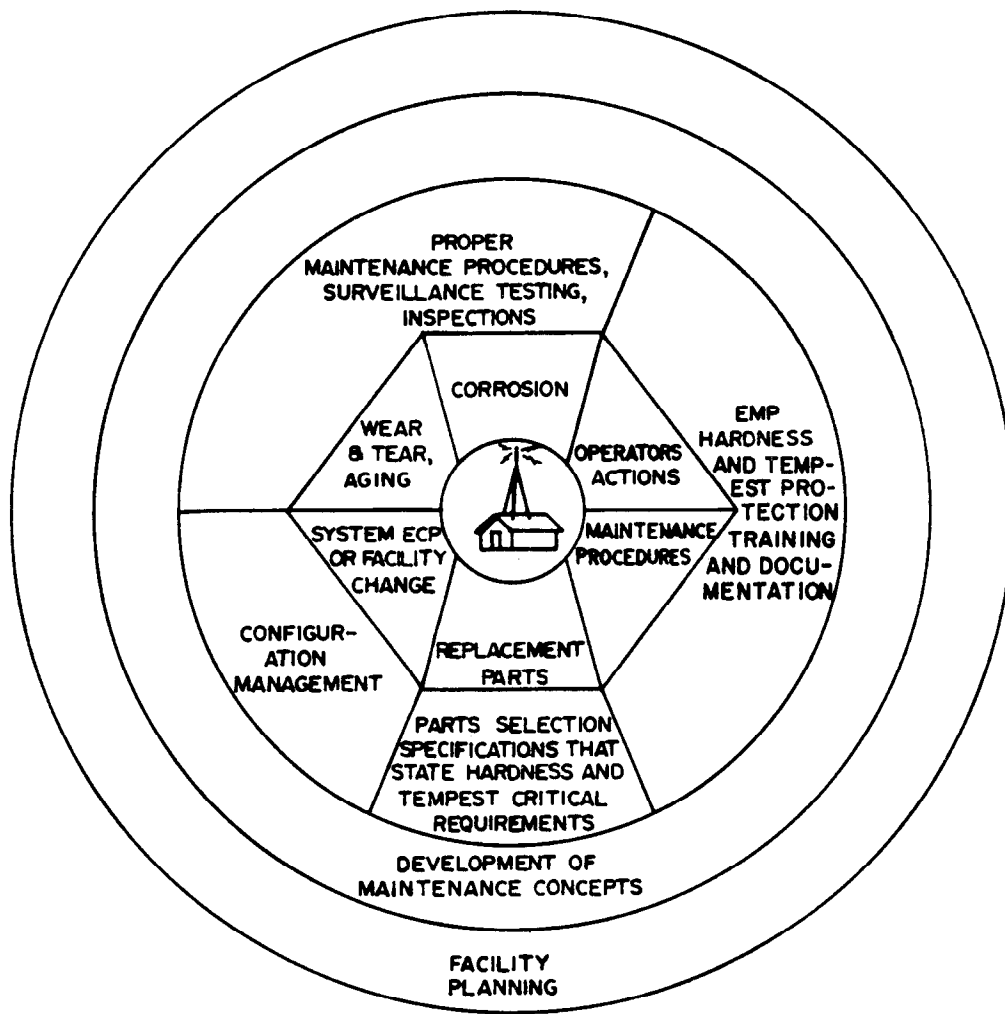


Figure 7-2. Interaction of HM/HS/TSM program elements.

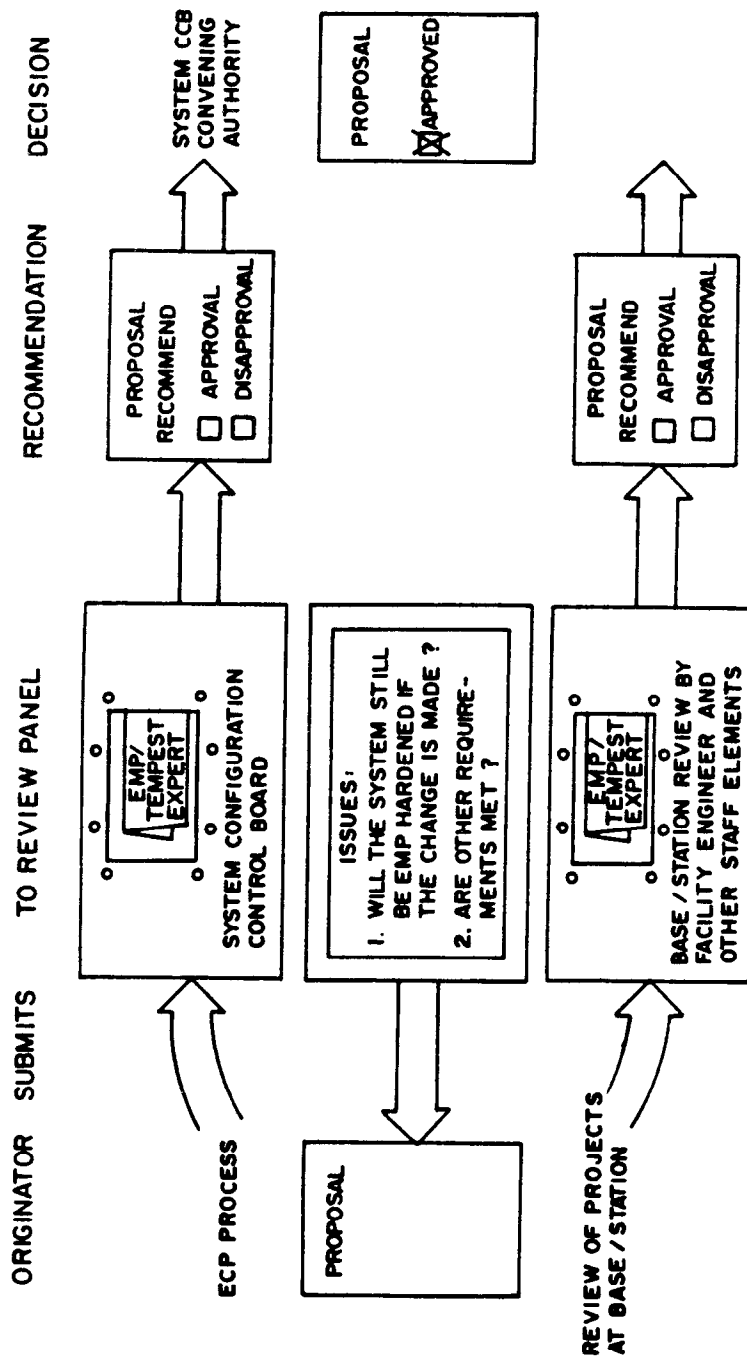


Figure 7-3. Configuration management process.

EP 1110-3-2
31 Dec 90

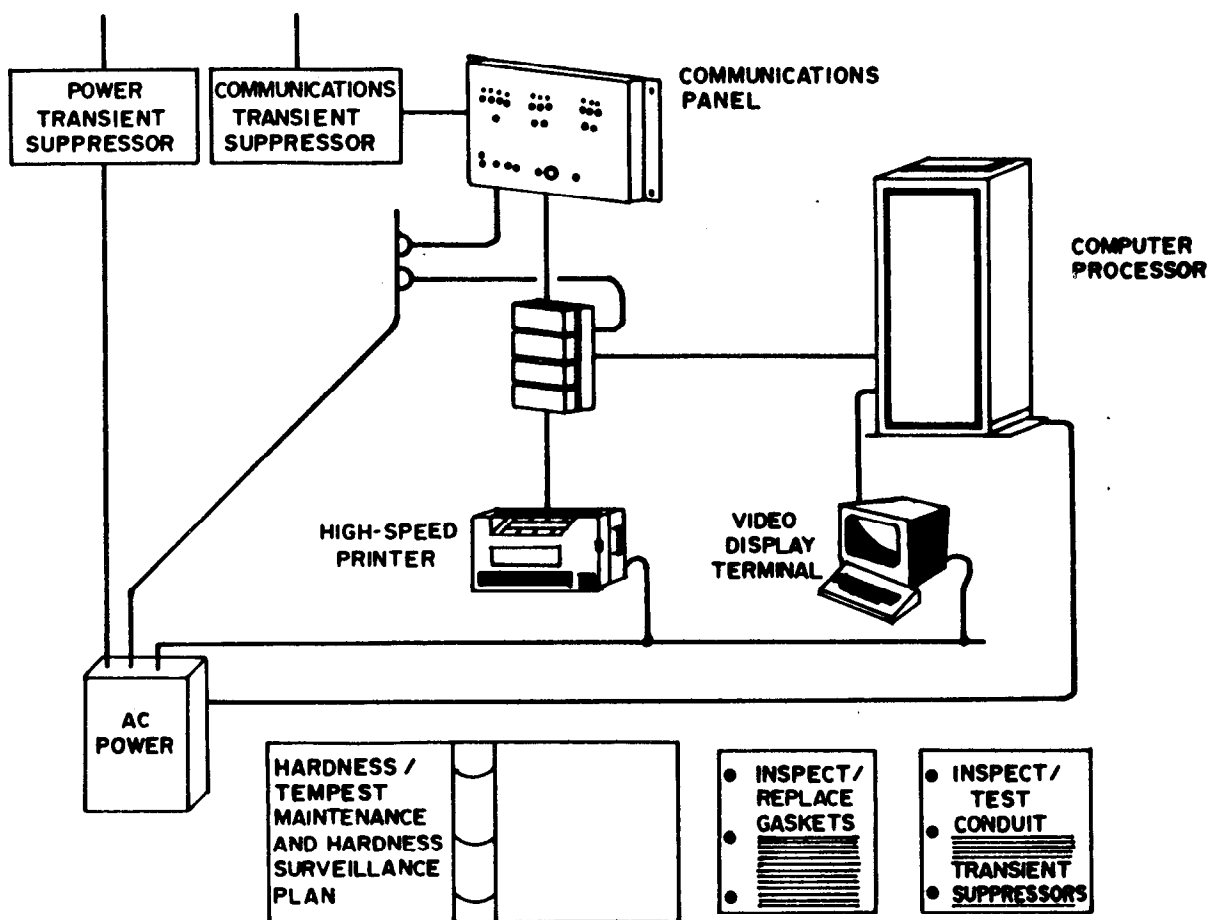


Figure 7-4. Example of maintenance procedures.

CHAPTER 8

EMP AND TEMPEST RISKS

8-1 Outline. This chapter is organized as follows:

- 8-1. *Outline*
- 8-2. *Introduction*
- 8-3. *EMP environment-- overview*
 - a. *General*
 - (1) *Classification of EMP*
 - (2) *High-altitude burst*
 - (3) *Generation of HEMP*
 - (4) *Compton electrons*
 - (5) *Relationships*
 - b. *Electric field*
 - c. *Magnetic field*
 - d. *Spatial extent*
 - (1) *Geographical coverage*
 - (2) *Surface area calculation*
 - e. *HEMP peak fields at the Earth's surface*
 - (1) *Orientation of Earth's geomagnetic field*
 - (2) *Geometric factors*
- 8-4. *Comparison of HEMP and lightning*
- 8-5. *TEMPEST risks*
 - a. *TEMPEST objectives*
 - (1) *Communication security (COMSEC)*
 - (2) *Parts of security*
 - (3) *Details of TEMPEST issues*
 - (4) *Theory of electromagnetic signal emanation*
 - (5) *Aim of TEMPEST discipline*
 - b. *Equipment emission characteristics*
 - (1) *RED and BLACK terminology*
 - (2) *Strength and nature of emanations*
 - (3) *Classes of equipment*
 - (4) *Project development brochure*
 - c. *Detection capabilities*
 - (1) *Electronic surveillance concerns*
 - (2) *Worst-case evaluation*
 - d. *TEMPEST isolation requirements*
 - (1) *Isolation approaches*
 - (2) *Recommended isolation concepts*
 - (3) *Design criteria*
 - e. *Installation within the shielded volume*
 - (1) *Precluding unintentional coupling*
 - (2) *Sources of additional information*
 - (3) *Limited exclusion area*
 - (4) *Spacing of equipment*

EP 1110-3-2
31 Dec 90

- (5) *Penetrations*
- (6) *Separating RED and BLACK*
- (7) *Telephones and intercoms*
- f. *Related TEMPEST documents*
 - (1) *National Security Agency documents*
 - (2) *National COMSEC Information Memorandums*

8-6. *Cited references*

8-2. Introduction. System design greatly influences the impact a HEMP event has on a facility. Thorough knowledge of the various modes of HEMP coupling to structures combined with system sensitivity information and TEMPEST risks can give designers better insight into HEMP hardening and TEMPEST protection requirements for critical facilities.

8-3. EMP environment--overview.

a. General.

(1) Classification of EMP. EMP can exist in many forms. Typically, EMP is classified in terms of the height of burst (HOB) of the detonation and its relative relationship with respect to the target or observer. For this pamphlet, only the high-altitude detonation is considered since this environment can be considered for all critical facilities. Additional scenario-dependent environments would apply to targeted facilities or those located near targets.

(2) High-altitude burst. A high-altitude burst occurs above approximately 30 kilometers and differs from surface and air bursts in that other associated nuclear effects do not occur on the ground. EMP is the major effect.

(3) Generation of HEMP. Figure 8-1 depicts the generation of HEMP. The gamma rays produced by the burst travel radially from the burst in a spherical shell that expands at the speed of light. Below 30 kilometers, the atmosphere is dense enough to cause gamma rays to be absorbed by Compton scattering. This effect results when gamma rays from the nuclear burst collide with air molecules. Absorption is nearly complete by the time the gamma rays reach an altitude of 20 kilometers. Thus, the source region for a high-altitude burst is located between 20 and 30 kilometers above the Earth's surface. This region is shaped like a pancake and its lateral extent is limited only by the curvature of the Earth.

(4) Compton electrons. At the altitude of the source region, the Compton electrons travel about 100 meters before they are absorbed. While traveling this distance, the electrons are strongly deflected by the Earth's geomagnetic field, making them turn with a radius of about 100 meters. Thus, the Compton current has large components in nonradial directions from the burst, i.e., transverse to the direction of the gamma-ray propagation, which are effective in generating radiated fields. The transverse Compton current

is the primary source of high-altitude radiated EMP. HEMP consists of radiated electric and magnetic fields that begin almost at once and persist for more than 100 seconds. Typically, for design-related considerations, only the fields produced in the first microsecond (early time) after the burst are considered. However, as the impacts of intermediate and late-time effects become better defined, additional consideration may be required.

(5) Relationships. In general, characteristics such as the spatial extent, time waveform, and peak amplitude of HEMP depend on the HOB, weapon yield, and observer's location with respect to the burst. The following paragraphs show the characteristics of a nonclassified but representative HEMP.

b. Electric field. The time waveform of a HEMP electric field, $E(t)$, in free space can be approximated by the analytic expression--

$$E(t) = \frac{kE_{pk} e^{a(t-t_s)}}{1 + e^{(a+b)(t-t_s)}} \quad (\text{kV/m}) \quad (\text{eq 8-1})$$

where the coefficients are given by--

- E_{pk} = 50 kV/m, the peak electric field (kV/meter)
- k = 1.2, a normalization constant
- a = $5 \times 10^8 \text{ sec}^{-1}$, the exponential rise rate (sec^{-1})
- b = $2.3 \times 10^7 \text{ sec}^{-1}$, the exponential decay rate (sec^{-1})
- T_s = 10^{-8} sec, the time shift parameter (sec)
- t = the time of interest (sec).

Figure 8-2 is a graphic representation of the HEMP waveform.

c. Magnetic field. The associated magnetic component of the radiated HEMP field can be obtained by dividing the electric field in volts per meter by 377 ohms. This gives the magnetic field in amps per meter with a peak value of about 135 amps per meter. It should be noted, however, that the values shown in figure 8-2 apply only to the free-field environment and not to the behavior of fields near conducting surfaces such as the surface of the Earth. Near such a conductor, the electric field will be much smaller because it is shorted out, whereas the magnetic field will be about twice its value in free space, or almost 270 amps per meter.

EP 1110-3-2
31 Dec 90

d. Spatial extent.

(1) Geographical coverage. The geographical coverage of HEMP over the Earth's surface is determined entirely by the HOB. The maximum ground range (tangent radius) depends on the tangent to the Earth from the burst point and is the arc length between this tangent and the point on the Earth's surface directly beneath the burst surface zero. To approximate this distance, the following calculation for tangent radius R_T (in kilometers) can be made:

$$R_T = R_E \cos^{-1} \left(\frac{R_E}{R_E + HOB} \right) \quad (\text{eq 8-2})$$

where $R_E = 6370$ kilometers (the approximate radius of the Earth) and HOB is the burst height in kilometers.

(2) Surface area calculation. The total surface area A_T in square kilometers covered by HEMP can be calculated as follows:

$$A_T = \frac{2(\pi)R_E^2 HOB}{R_E + HOB} \quad (\text{eq 8-3})$$

Figure 8-3 applies this information to the United States, showing ground coverage for bursts of 50 and 120 miles over the central portion.

e. HEMP peak fields at the Earth's surface.

(1) Orientation of Earth's geomagnetic field. Since the motion of the Compton electrons depends on the orientation of the Earth's geomagnetic field, the incident HEMP fields vary significantly in peak amplitude, rise time, and duration over the large area affected by the HEMP. The maximum peak electric field E_{max} occurs just south of ground zero and can be as high as 50 kilovolts per meter, depending on the HOB and the weapon yield. The peak field E_{pk} observed at any other location is some fraction of E_{max} .

(2) Geometric factors. In addition to the orientation and dip of the geomagnetic field, geometric factors based on the observer's position with respect to the burst also cause spatial variations of the HEMP field strength. In the figure, the null area slightly north of the burst point is produced by the geomagnetic dip over the CONUS; Compton electrons created in the same direction as the Earth's geomagnetic field do not turn and no radiated fields

are created. The maximum peak fields are found at a distance equal to about twice the HOB south of surface zero.

8-4. Comparison of HEMP and lightning. HEMP-induced surge currents on overhead transmission lines are similar to, but not exactly the same as, lightning-induced surges. Table 8-1 compares worst-case surges. From the numerical values, it could be inferred that lightning is a more serious threat. The values for lightning, however, represent the 99th percentile of all measurements on standard lightning discharges, and thus may not be representative of the strokes that occur near a given facility. In contrast, the HEMP pulse is not a localized phenomenon, but illuminates a very wide area. As a result, any hardened facility would see a HEMP-induced current if there were a war, while it might never be exposed to the maximum lightning current. In addition, there are significant differences in pulse rate and frequency content. For this reason, it cannot be assumed that standard lightning protection is an adequate substitute for HEMP protection.

8-5. TEMPEST risks.

a. TEMPEST objectives.

(1) Communication security (COMSEC). Communication security (COMSEC) is the term used to denote steps taken to prevent disclosure of national security information to unauthorized recipients during the communication process. NTISSI 7000 and AR 530-4 define minimum measures that must be taken to protect CONUS facilities (refs 8-1 and 8-2). The information to be guarded includes plain text of classified messages, as well as cryptographic technology and materials. Cryptographic information is especially sensitive, not as an end in itself, but because it is used to protect other classified data. If the integrity of an encryption system is breached at any point, all classified information protected by that coding may be compromised.

(2) Parts of COMSEC. COMSEC consists of four main parts: physical security--all physical measures to safeguard materials from unauthorized access; emissions security--control of emanations from equipments processing classified data; transmission security--protection of transmissions from traffic analysis, imitative deception, and disruption; and cryptographic security--the use of technically sound cryptosystems. Only the emissions security discipline or TEMPEST is specifically addressed in this manual.

(3) Details of TEMPEST issues. Because the details of many TEMPEST issues are classified and controlled under strict conditions of need-to-know, the following discussions must be somewhat general. Nevertheless, it provides the reader with a needed appreciation of TEMPEST fundamentals.

(4) Theory of electromagnetic signal emanation. Any electrical/electronic circuit that carries a time-varying current will emanate electromagnetic signals with the strength of the emission proportional to the current amplitude and its time rate of change. These signals propagate

EF 1110-3-2
31 Dec 90

outward from the source as free space waves and as guided waves along conductors connected to or close to the radiator. If time variations of the source currents are related in any way to the information content of the signals (which will almost certainly be the case on a data line), then the emanation will also bear some relationship to the data. It may, therefore, be possible to reconstruct the original intelligence by analysis of these unintentional emissions.

(5) Aim of TEMPEST discipline. Finally, if the source information is classified, interception and analysis of the emanations by unauthorized personnel will compromise national security. The aim of the TEMPEST discipline is to control stray emissions in a manner that prevents such disclosures.

b. Equipment emission characteristics.

(1) RED and BLACK terminology. Before addressing the emission characteristics issue, the RED and BLACK terminology will first be introduced. A RED equipment or circuit is one that handles plain text information with national security value. Equipment processing signals that are unclassified, either because of content of the text or because the intelligence is obscured by encryption, is denoted in BLACK.

(2) Strength and nature of emanations. The unintentional emission characteristics of RED systems and equipments are categorized according to strength and nature of their emanations. The reason for the strength element is clear: high-level signals can be intercepted at magnitudes that permit analysis with greater physical separations between the source and the eavesdropper. The second factor relates to the correlation between waveform of the emitted signal and the information to be protected.

(3) Classes of equipment. For purposes of facility engineering and construction within the limitations of this manual, it is only necessary to define two classes:

(a) Equipments that are TEMPEST-approved according to the criteria established in the current edition of NACSIM 5100 (ref 8-3).

(b) All equipments that have not been TEMPEST-tested or are nonapproved.

(4) Project development brochure. Information regarding the category of RED equipment to be protected should be presented in the project development brochure prepared by the user of the facility.

c. Detection capabilities.

(1) Electromagnetic surveillance concerns. Concerns about electromagnetic surveillance have been intensified by advances in state-of-

the-art equipment design and signal processing techniques. While a few technologies such as fiber optics and multiplexing have made interception and analysis more difficult, the overall effect has been to open new opportunities for eavesdroppers. Projections into the immediate future indicate that this trend will continue.

(2) Worst-case evaluation. The only safe approach is a reasonable worst-case evaluation. It must be assumed that the opposition has the proper equipment to monitor all signals of significant amplitude in areas where access is uncontrolled.

d. TEMPEST isolation requirements.

(1) Isolation approaches. Encryption is the method used to guard against disclosure of classified information when long-distance telecommunications are monitored. However, it does not prevent possible compromise through interceptions and analyses of unintentional emanations from RED equipments.

(a) Many approaches are available to equipment and facility designers to avoid disclosures through potentially compromising emanations. All of these techniques reduce the stray signal strength at locations where access is uncontrolled, so that the intelligence content is lost in the background electrical noise. AR 530-4 should be consulted to determine the level of protection required.

(b) Examples of preventive measures include the following:

- Physical separation--excluding unauthorized individuals from areas near the source where the emanations are larger in amplitude than the ambient noise.

- Electromagnetic separation--the use of shielding, filtering, and other methods of EM isolation to attenuate the unintentional emissions.

- Signal level minimization--design and operation of circuits at lowest feasible power levels to minimize the strength of unintentional emissions.

(c) These methods can be employed in an infinite variety of combinations to achieve the desired goals.

(2) Recommended TEMPEST isolation concept. NTISSI 7000 and AR 530-4 analysis is the first step in determining needed TEMPEST countermeasures. Shielding for TEMPEST is not necessarily required; however, for facilities having high-confidence HEMP survivability specifications and being hardened in accordance with recommendations of this manual, it is technically prudent and highly cost-effective to include TEMPEST shielding and penetration protection

EP 1110-3-2
31 Dec 90

in a common subsystem. The suggested TEMPEST isolation concept takes advantage of this principle.

(a) The first requirement, a physical security measure, is the establishment of a controlled space (CS) containing the equipment to be TEMPEST-protected and within which access is not available to those not authorized to receive the information being processed at the site.

(b) NACSEM 5204 defines the detailed procedures to compute shielding effectiveness requirements for specific TEMPEST applications (ref 8-4). Parameters of the problem include measured emission characteristics of the equipments and distance to the perimeter of the controlled space. The calculation determines the attenuation needed to reduce emanation levels below detectable limits in the ambient noise environment. If reasonable worst-case assumptions are made regarding the variables, however, then 50 decibels (nominal) attenuation is adequate for an installation within CONUS. This requirement can be met by a shield and penetration treatments that conform to Specification NSA No. 73-2A.

(c) NSA 73-2A is an appendix in NACSEM 5204. The document also contains Specifications NSA No. 65-5 and 65-6 for TEMPEST applications where greater shielding effectiveness requirements exist. DIAM 50-3A should be consulted for SCIF shielding information (ref 8-5).

(3) TEMPEST design criteria. Since electromagnetic performance requirements of a 50-decibel (nominal) TEMPEST design are quite consistent with performance necessary for HEMP considerations and only a few additional features are prescribed for the shielding and penetration protection subsystem, the reasonable worst-case TEMPEST assumptions have been incorporated into the recommended HEMP/TEMPEST approach. The following paragraphs summarize the TEMPEST-unique requirements for facility design.

(a) Shielding effectiveness. Minimum attenuation levels of the shielded enclosure, when measured in accordance with NSA 73-2A, are as shown in figure 8-4. This curve contains a slight increase in the requirements at frequencies above 500 megahertz compared with values prescribed in NSA 73-2A. The upper frequency of the shielding effectiveness and filter insertion loss frequency have also been extended as high as 10 gigahertz. The site-specific requirements should be determined by consulting with the using agency.

(b) Shield doors. TEMPEST shield design includes a shielded vestibule entrance arrangement with two doors oriented at 90 degrees to each other. The purpose of double doors is the same as that cited for HEMP--to preserve the shielding effectiveness during actual entries and exits. Effectiveness requirements for the doors are the same as those for the main shield.

(c) Piping and ventilation penetration. Mechanical penetrations, piping, and air ducts are to be bonded to the shield at the point of penetration. The design must be configured as a waveguide-beyond-cutoff to attenuate all frequencies within the specified band, as shown in figure 8-5.

(d) Electrical penetration. The specification requires that a filter providing at least 50 decibels of insertion loss from 14 kilohertz to the upper design protection frequency, typically 1 to 10-gigahertz upper frequency when measured in accordance with procedures of MIL-STD-220A, be installed on each power, telephone, and signal line that penetrates the enclosure shield wall (ref 8-6). (Note: Other forms of isolation, such as optical or pneumatic decouplers, which accomplish the same purpose, may be used and special performance specifications for filters on conductors with operating signals in the 14 kilohertz to 1-10 gigahertz band may be established, subject to the approval of the using agency.)

e. Installation within the shielded volume.

(1) Precluding unintentional coupling. It is virtually certain that the volume enclosed by the TEMPEST shield will contain some BLACK equipment and wiring, as well as RED circuits that handle national security information. Therefore, the facility design and hardware/wiring layouts must preclude unintentional coupling of RED emanations into BLACK conductors. These measures are above and beyond the shielding and penetration protection subsystem features and are necessary whether or not a shield is provided.

(2) Sources of additional information. The guidelines and requirements for RED/BLACK isolation are published in NACSIM 5203 (ref 8-7) and MIL-HDBK-232A (ref 8-8). Since some details of the specified practices are classified, this discussion must be considered incomplete, and the designer must also consult NACSIM 5203 and MIL-HDBK-232A to comply with the minimum requirements.

(3) Limited exclusion area. The room or area within which RED equipment is located and to which controls are applied for protection of national security information is known as a limited exclusion area (LEA). The TEMPEST shield may enclose part or all of the LEA and might also envelope other spaces.

(4) Spacing of equipment. RED equipment must be physically separated from the facility walls and ceiling, from BLACK equipment and wiring, and from utility conductors such as ventilation ducts and piping. Minimum required spacings depend on whether the RED equipment is low-level signaling, TEMPEST-approved hardware or not, and on the nature of possible propagation paths between the BLACK element and an area of uncontrolled access.

(5) Penetrations. Physical separation practices, as well as special shielding and distribution (for example, using conduits, ducts, and trays) instructions, also apply between RED and BLACK wiring in the LEA. Specific

EP 1110-3-2
31 Dec 90

guidelines are presented in NACSIM 5203 for signal lines, telephone/communication cables, power feeders, ground wires and other utility (air-conditioning control and status, fire alarm) electrical conductors. Markings with paint or tape are prescribed to distinguish RED wiring runs from BLACK cables, and RED conduits must be accessible for inspection.

(6) Separating RED and BLACK. Also, depending on characteristics of the RED equipment, separate filter-isolated RED and BLACK power distribution subsystems or individual equipment power filters may be required. Further, it may be necessary to provide separate and distinctively identified RED and BLACK convenience outlets.

(7) Telephones and intercoms. Administrative telephone and facility intercommunication subsystems require particular attention. The most effective protection is to eliminate or, at least, minimize the number of instruments in the LEA. If exclusion is not practical, separation, shielding, and filter isolation devices and positive disconnect capabilities are to be provided as prescribed in NACSIM 5203.

f. Related TEMPEST documents.

(1) National Security Agency documents. The reader desiring additional background material concerning TEMPEST and needing specific implementation information is directed to the series of TEMPEST source documents published by the National Security Agency (NSA). Supplementary use of these references during facility design and construction phases is imperative because classification considerations limit the information incorporated in this manual to generalized discussions. Only the shielding and penetration protection requirements are included in this manual.

(2) National COMSEC Information Memorandums. NACSIM 5000 provides an overall introduction to the TEMPEST discipline (ref 8-9). NACSIM 5203 and NACSEM 5204 are essential to the project for defining installation requirements within the protected volume and the shielded enclosure requirements, respectively (refs 8-7 and 8-4). Other documents to which the reader may wish to refer include: NACSI 5004 (ref 8-1), NACSI 5005 (ref 8-10), NACSIM 5100A (ref 8-3), NACSEM 5109 (ref 8-11), NACSEM 5110 (ref 8-12), and NACSEM 5201 (ref 8-13). The military departments (MILDEPs) also publish TEMPEST regulations and guidance; access to these documents can be obtained through the appropriate MILDEP communication security agency.

8-6. Cited references.

- 8-1. National Telecommunications and Information System Security Instruction (NTISSI) 7000, 17 October 1988.
- 8-2. Army Regulation (AR) 530-4, (U) Control of Compromising Emanations (Headquarters, Department of the Army [HQDA]) (C).

EP 1110-3-2
31 Dec 90

- 8-3. National COMSEC Information Memorandum (NACSIM) 5100A, (U) Compromising Emanations Laboratory Test Requirements, Electromagnetics (NSA) (C).
- 8-4. National COMSEC/Emergency Security (EMSEC) Information Memorandum (NACSEM) 5204, (U) Shielded Enclosures (NSA, January 1979) (C).
- 8-5. Defense Intelligence Agency Memorandum (DIAM) 50-3A, Physical Security Standards for Sensitive Compartmented Information Facilities (Defense Intelligence Agency, 2 October 1984).
- 8-6. Military Standard (MIL-STD) 220A, Method of Insertion-Loss Measurement (Department of Defense [DOD], 15 December 1959).
- 8-7. NACSIM 5203, (U) Guidelines for Facility Design and RED/BLACK Installation (NSA, 30 June 1982) (C).
- 8-8. Military Handbook (MIL-HDBK) 232A, (U) RED/BLACK Engineering Guidelines (DOD, 25 April 1980) (C).
- 8-9. NACSIM 5000, (U) TEMPEST Fundamentals (NSA, 1 February 1982) (C).
- 8-10. National COMSEC Instruction (NACSI) 5005, (U) TEMPEST Countermeasures for Facilities Outside the United States (NSA, January 1984) (S).
- 8-11. NACSEM 5109, (U) TEMPEST Testing Fundamentals (NSA) (C).
- 8-12. NACSEM 5110, (U) Facility Evaluation Criteria--TEMPEST (NSA, July 1973) (S).
- 8-13. NACSEM 5201, (U) TEMPEST Guidelines for Equipment/System Design (NSA, September 1978) (C).
- 8-14. DNA EMP Course Study Guide, draft prepared for Defense Nuclear Agency (The BDM Corporation, April 1983).

EP 1110-3-2
31 Dec 90

Table 8-1. Comparison of HEMP with lightning-induced stresses on long overhead power lines.

HEMP phenomenon	V_{\max} (MV)	I_{\max} (kA)	dV/dt (kV/ns)	dI/dt (A/ns)	$\int Idt^2$ (Coulombs)	$\int I dt$ (A ² -sec)	$\int IVdt$ (Joules)
HEMP on long overhead power lines	6	14	40	100	10^{-2}	150	6×10^4
HEMP on short overhead power lines	1	2.5	40	100	2×10^{-3}	5	2×10^3
HEMP on buried power lines	1	2.5	8	20	--	--	--
Direct lightning strokes (Max) (Typical)	100 10	100 25	0.8 to 8	2 to 100	40	3.1×10^6	1.2×10^8
Indirect lightning strokes (Max)	6	15	--	--	4.5	1.8×10^4	7×10^6

Voltage computations assume a nominal power line surge impedance of 400 ohms. Lightning discharge estimates do not consider so-called "positive superbolts" which are anomalies, but are roughly 10 times more severe than normal lightning bolts.

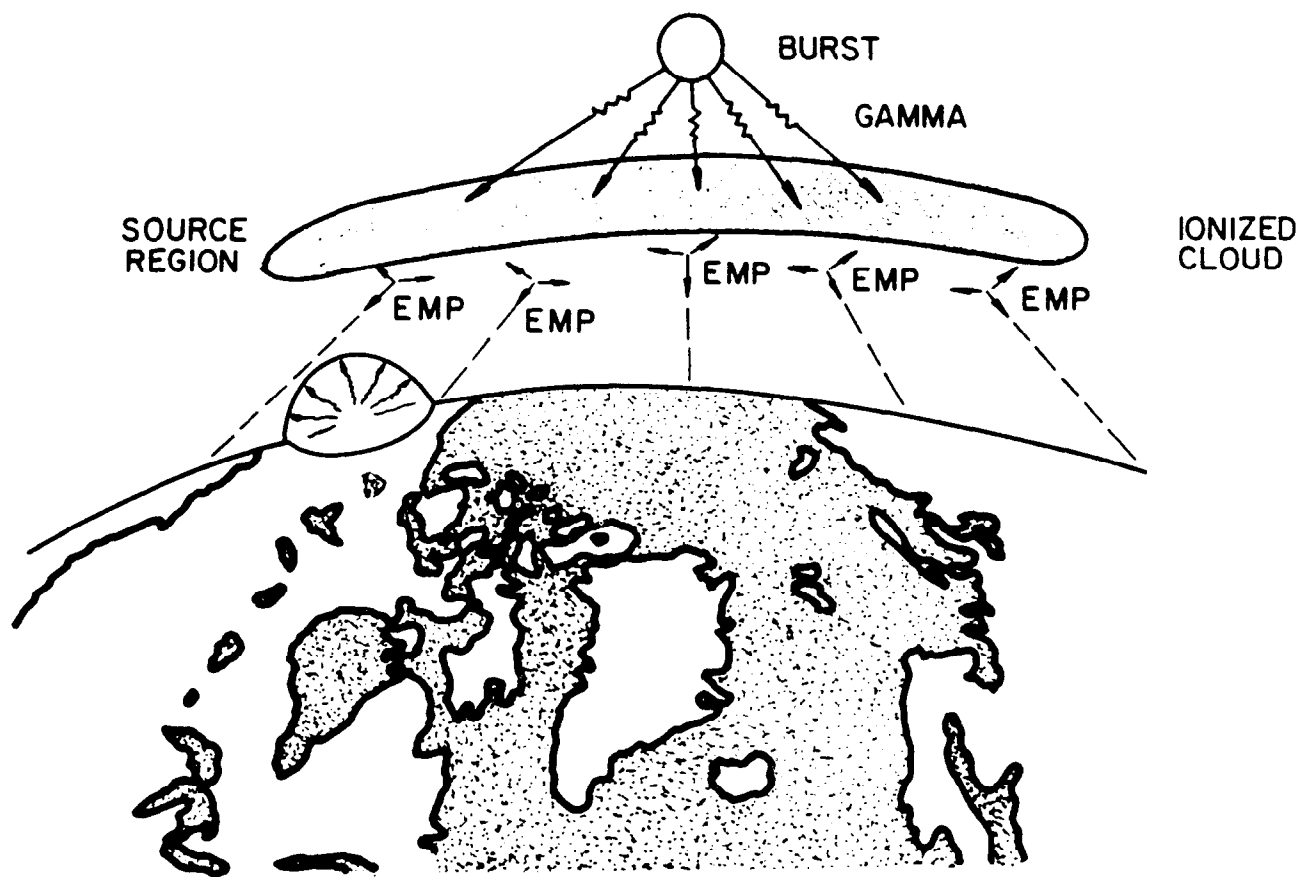


Figure 8-1. Near-surface and exoatmospheric blasts.

EP 1110-3-2
31 Dec 90

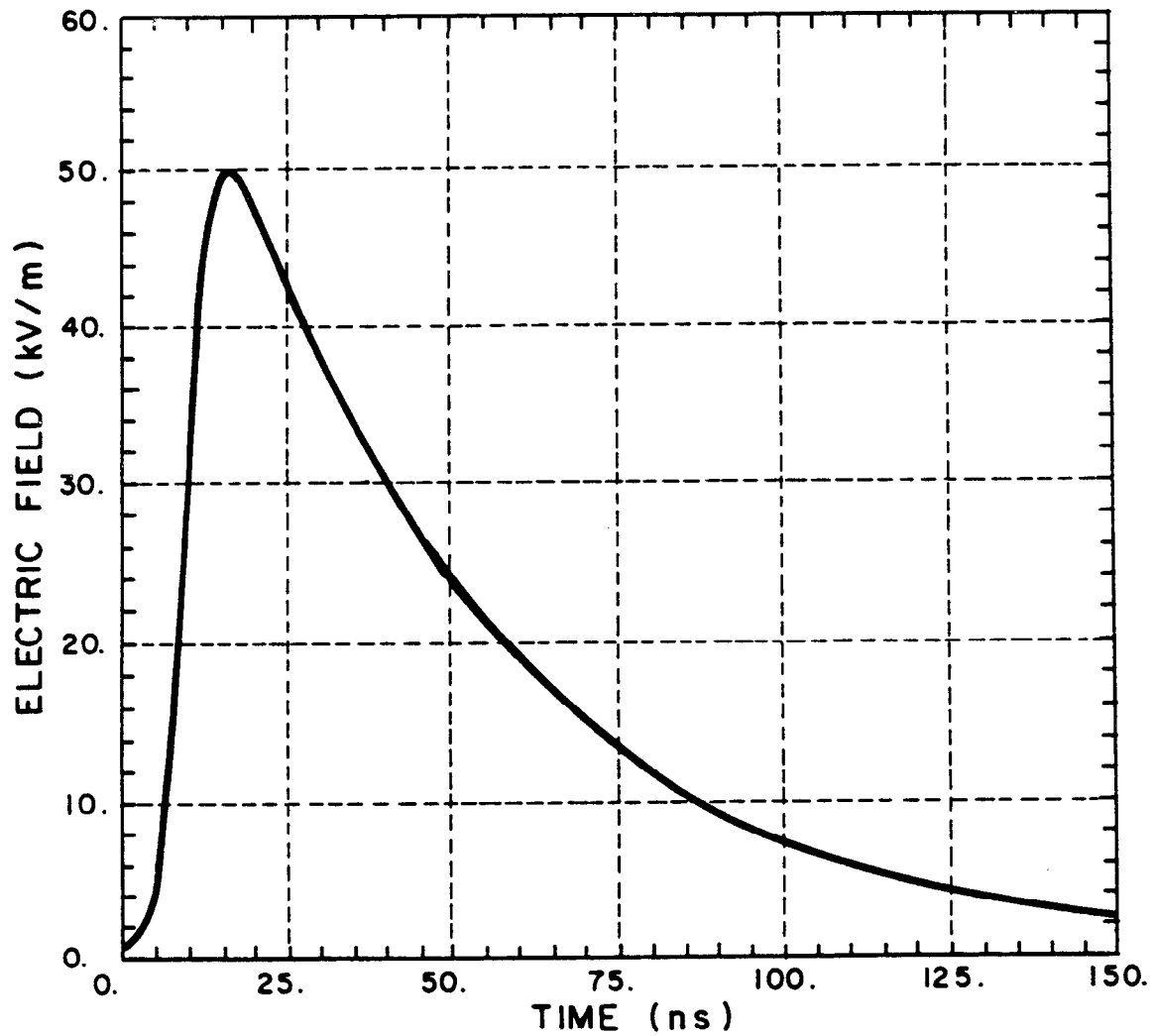


Figure 8-2. Time waveform for the free-field HEMP electric field.

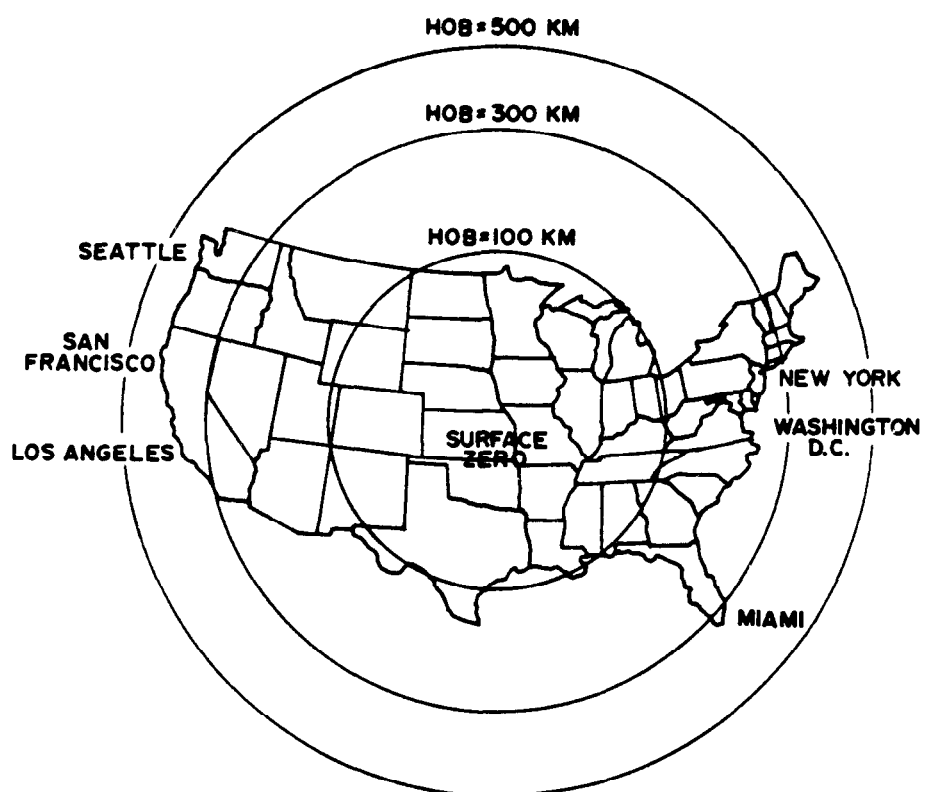


Figure 8-3. HEMP ground coverage for bursts of various heights above the United States. (Source: ref 8-14)

EP 1110-3-2
31 Dec 90

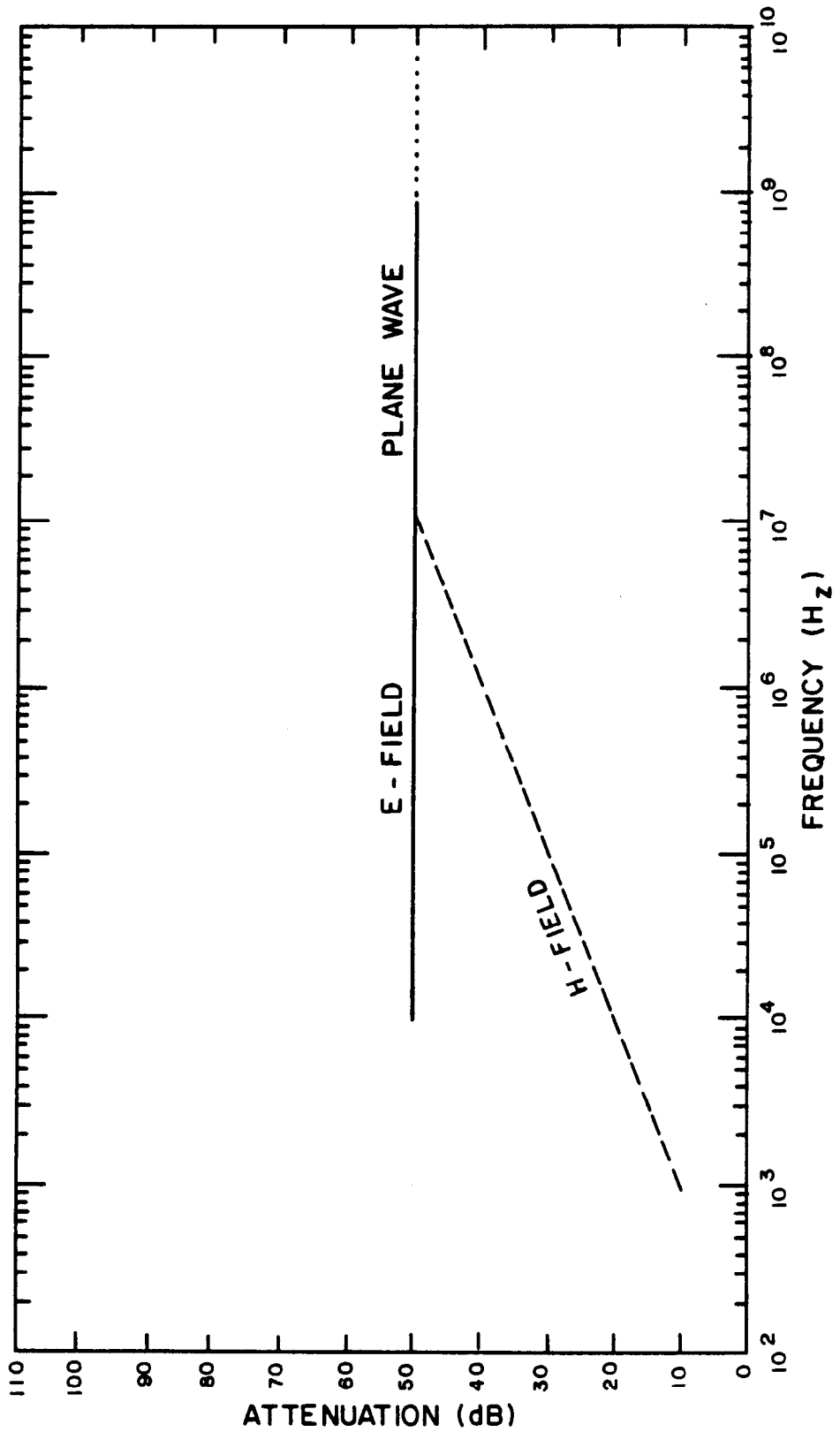


Figure 8-4. Reasonable worst-case TEMPEST shielding attenuation requirement.

EP 1110-3-2
31 Dec 90

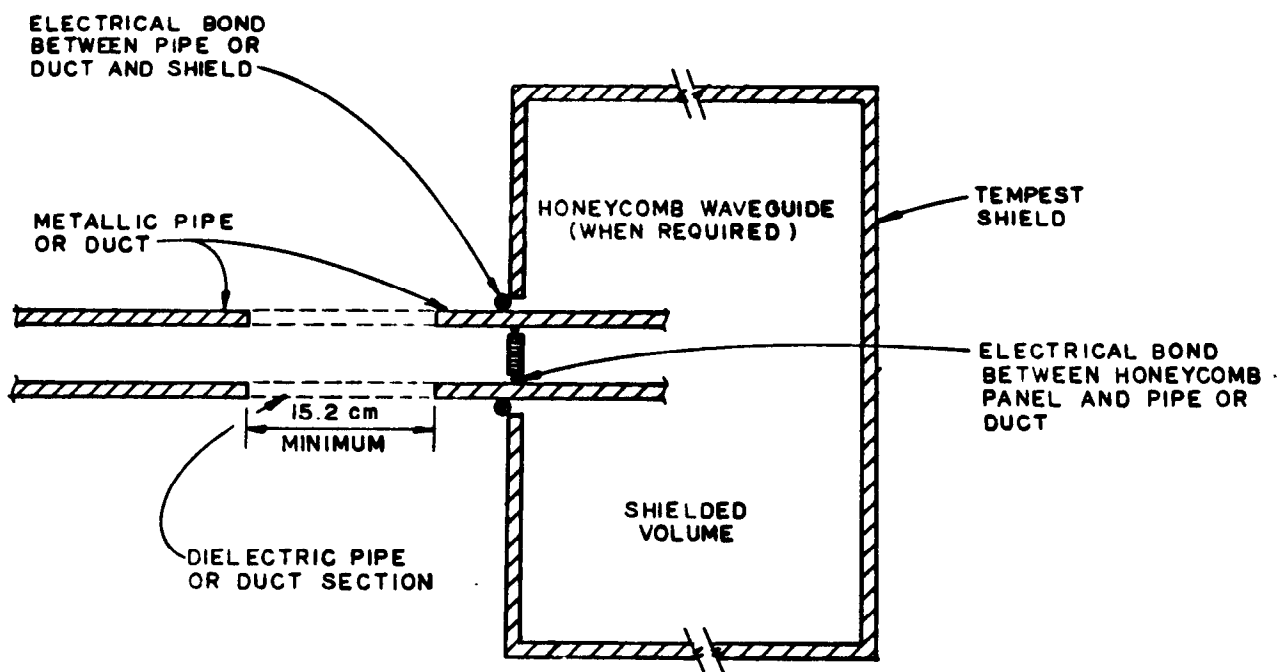


Figure 8-5. Fifty-decibel (nominal) TEMPEST pipe or air duct penetration design.

CHAPTER 9

EMP AND TEMPEST PROTECTION CONCEPTS

9-1. Outline. This chapter is organized as follows:

9-1. Outline

9-2. Introduction

- a. Component or room hardening*
 - (1) Equipment separation distances*
 - (2) Component shielding*
- b. Facility shielding*
 - (1) Waveguide tunnel*
 - (2) Grounding system*
 - (3) Uninterruptible power supply*
 - (4) Conduit runs*
- c. Zoning*
 - (1) Reason for zoning*
 - (2) Typical zones*
- d. Global approach*
 - (1) Programing and design*
 - (2) Off-the-shelf products*
 - (3) Performance degradation*
 - (4) Project costs*
 - (5) Envelope*

9-3. TEMPEST requirement in relation to HEMP

- a. Shielding similarity*
- b. Peak power comparison*
- c. Upper frequency range*
- d. Critical component location*
- e. Dielectric breaks*
- f. Common hardening*

9-4. Generic facility hardening

- a. Overview*
- b. EMP protective features*

9-2. Introduction. Critical facilities are very vulnerable to HEMP damage or upset and, in most cases, these facilities have equipment that processes classified information that could be compromised. A single nuclear weapon detonated 300 kilometers above the United States can blanket the entire CONUS area with HEMP effects. HEMP effects are especially damaging to integrated circuits and other sensitive low-voltage/current electronic devices on which facilities rely. It is critical to national security that these facilities incorporate HEMP and TEMPEST protection measures to prevent compromise of information and disastrous damage and upset to the electronics equipment. Generally, there are two concepts to be considered as a methodology for HEMP

EP 1110-3-2
31 Dec 90

and TEMPEST protection and a zoning plan which may be applied to either methodology as required.

a. Component or room hardening. This method consists of defining a subset of equipment that is mission-essential and hardening only that equipment and its required auxiliaries. This method is employed in two circumstances:

(1) Equipment separation distances. Equipment is physically separated by large distances and it is not realistic to try to shield the entire area.

(2) Component shielding. The mission-essential equipment is in a facility where it comprises only a small relative part, and thus, it is not advisable to shield the entire facility. When this method is used, each system or piece of equipment is considered a separate entity for shielding. This method employs either small shield rooms or shielded equipment with waveguides-beyond-cutoff (WBC), electric filters, access panels, and RF doors. It differs from facility shielding only in scale. The drawbacks with component shielding are that it is totally inflexible, very expensive, and very difficult to maintain. Also the system is vulnerable during servicing when access panels are open. This method is usually cost-effective only in the circumstances outlined above.

b. Facility shielding. This method is by far the most common for high-level HEMP and TEMPEST protection. It maximizes flexibility since any standard equipment can be used inside the shielded facility. Facility shielding may be low-level or high-level (50- or 100-decibel) attenuation. HEMP shielding (100-decibel) consists of at least 3/16-inch welded steel (12-gauge walls and 10-gauge floors are recommended). TEMPEST shielding (50-decibel) consists of at least 22 to 26 gauge steel walls, floors, and ceiling with clamped joints. All penetrations are protected by WBC, filter or RF seal of some kind. Penetrations should be reduced to a minimum and if possible colocated at one area of the facility in a penetration entry room (PER) or vault. A PER is a small, shielded room that affords extra protection to the facility where all, or most, utilities enter. It is placed on the outside skin of the building using the exterior of the facility shield as an interior wall. The PER is especially effective in control of all penetrations and provides a desirable margin of safety for critical facilities.

(1) Waveguide tunnel. A waveguide tunnel shall be provided for large facilities at the main personnel entry. This long, welded tunnel can provide up to 40 decibels of attenuation (more at low frequencies). It offers valuable protection at the weakest point of the shield. RF doors shall be installed at both ends of the entryway tunnel, interlocked to ensure that only one may be opened at any time. No conductive lines are permitted in the tunnel; lighting shall be provided from above the tunnel through a WBC vent in the ceiling or the lighting circuit shall be protected by a filter.

(2) Grounding system. The grounding system for the facility shall use an equipotential ground and tie into a welded stud that does not penetrate the

shield. Another stud welded to the opposite side should then run to the exterior ground system.

(3) Uninterruptible power supply. Generally, an uninterruptible power supply (UPS) is used to provide power when the commercial source fails during a HEMP event. The UPS is usually contained inside the shield and is often used on a daily basis to provide clean power for computers and mission equipment. Surge arresters shall be used to clamp the HEMP transient pulse on long commercial power lines; the electrical surge arresters also serve to protect the filters from the high voltages, currents, and energies in the HEMP pulse.

(4) Conduit runs. Wherever conduit runs must exit the facility to access some critical equipment such as an outside shielded generator, heavy metal rigid conduit shall be welded at the couplings to form an RF-tight shield. All conduit runs in the PER shall also be heavy metal rigid welded conduit. The conduit extends the shield to envelope critical shielded equipment outside the protected facility.

c. Zoning.

(1) Reason for zoning. Zoning is a method for control used when differing levels of protection are required. For example, the rugged generator set may operate without problems in a very low-level attenuation area, perhaps only under an earth rebar structure. A more sensitive UPS and communication room may require a low to medium protection level of 60 decibels, and a very sensitive control and computer room may require a high level (100-decibel) protection area.

(2) Typical zones. Protected areas can be designated Zone 0 for outside, Zone 1 for generator (40 decibels) area, Zone 2 for UPS and communication area, and Zone 3 for the highly sensitive control room. The zones can be drawn schematically and usually are nested one inside the other so that the highest attenuation area is centered inside the other areas. This method ensures that no potential compromise is overlooked, and the potential savings from nested/layered shielding can be realized. Zoning can be used for component or facility shielding and serves as an excellent tool for deciding what is critical and how it should be protected.

d. Global approach. In global shielding, a single requirement (e.g., 100 dB reduction or 50 dB reduction) is established as the protection level the design must meet. The approach has some advantages, including the following:

(1) Programing and design. Facility programing and design can proceed without an in-depth knowledge of the emanation and susceptibility profiles of the equipment to be housed within the building. Thus, the project can go forward in parallel with development of the mission hardware.

EP 1110-3-2
31 Dec 90

(2) Off-the-shelf products. Construction components and materials are generally off-the-shelf commercial products. Processes used to assemble the HEMP/TEMPEST protection subsystem are common in the design and construction trades.

(3) Performance degradation. This approach minimizes the potential for performance degradation of the subsystem and also minimizes the need for routine maintenance.

(4) Project costs. Overall project cost to the government may be reduced because no extraordinary electromagnetic susceptibility requirements need to be levied on the mission equipment manufacturers. Furthermore, hardware developed for non-HEMP/TEMPEST applications can normally be used without modifications.

(5) Envelope. This approach creates a protected envelope within which equipment and configuration changes can be made without modifying the isolation subsystem.

9-3. TEMPEST requirement in relation to HEMP.

a. Shielding similarity. Shielding and penetration protection techniques are efficient and effective for limiting the passage of electromagnetic energy in either direction--inward in the case of HEMP and in an outward direction for TEMPEST isolation requirements. A single electromagnetic barrier can perform both functions. This approach avoids costs and potential interaction effects associated with double shielding or double filtering.

b. Peak power comparison. The peak power of the HEMP environment is much greater than that in a potentially compromising TEMPEST emanation. Therefore, HEMP protection devices are constructed to survive greater stresses than TEMPEST protection devices.

c. Upper frequency range. TEMPEST protection extends to an upper design protection frequency, typically 1 to 10 gigahertz. This range will require the shield penetrations such as waveguides-beyond-cutoff and filter assemblies to provide protection at this frequency.

d. Critical component location. The conflicts are found when requirements of the two disciplines are compared. HEMP survivability considerations dictate that mission-critical modulator/demodulators (MODEMs) and radio transmitters be afforded the protection provided by the shielding and penetration subsystem. TEMPEST guidelines, in contrast, indicate that these BLACK devices be placed external to the shield. To meet both requirements, the MODEMs and transmitters can be located within the shielded enclosure, provided that RED/BLACK isolation procedures are followed and all associated electrical lines penetrating the shield are filtered properly or otherwise isolated.

e. Dielectric breaks. The second area of conflict relates to the nonconductive section required by TEMPEST considerations in piping, ventilation, and some electrical penetrations. From a HEMP protection standpoint, such dielectric breaks are undesirable. The nonconductive sections should be eliminated where the HEMP threat is increased by their inclusion (such as electrical conduit runs).

f. Common hardening. The facility hardening as provided for HEMP in all other areas of this pamphlet will also provide protection for TEMPEST.

9-4. Generic facility hardening.

a. Overview. Provide a welded facility shield that attenuates the EMP to an acceptable level (usually 80 to 100 decibels, depending on the susceptibility of equipment to a HEMP event). All conductive utility lines are circumferentially welded to the shield and PVC or other nonconductive lines are used in conjunction with WBC-type entries. Telephone lines should be fiber optic (preferred) or filtered. Power lines and antenna lead-ins must be filtered, preferably with electric surge arresters to protect the more expensive filters. The shield is provided with a grounding grid to ensure a good path to ground. Air-conditioning vents and ducts are provided with honeycomb WBC filters. This system provides protection for most of the equipment; however, certain items (such as computers) also may need separate shielded enclosures to attenuate the EMP to a tolerable level. Finally, onsite generators usually exist to sustain mission-essential equipment until commercial power can be restored and to isolate the site from the power lines.

b. EMP protective features. To protect susceptible mission equipment from upset or damage due to the HEMP free-field environment or coupled transients, the following HEMP protective features will ensure a hardened facility:

- (1) Welded facility shield.
- (2) RFI doors (fingerstock).
- (3) Waveguide entries.
- (4) Waveguide vents.
- (5) Waveguide-beyond-cutoff.
- (6) Dielectric inserts.
- (7) Fiber optic signal and communication lines.
- (8) Filters and surge arresters.
- (9) RFI-tight conduit runs and grounding system.

CHAPTER 10

SYSTEM INTEGRATION

10-1. Outline. This chapter is organized as follows:

- 10-1. *Outline*
- 10-2. *Introduction*
 - a. *Protection systems-- group 1*
 - b. *Internal systems-- group 2*
 - c. *Environmental systems-- group 3*
- 10-3. *Protection system integration*
 - a. *Electromagnetic compatibility/interference*
 - b. *Lightning*
 - c. *Physical security*
- 10-4. *Internal systems*
 - a. *Safety and fire protection*
 - b. *Grounding and bonding*
 - c. *Corrosion*
- 10-5. *Environmental systems*
 - a. *Thermal expansion/contraction*
 - b. *Vibration and noise*
 - c. *Shock and ground motion*
- 10-6. *General integration*
 - a. *Electrical*
 - b. *Mechanical*
 - c. *Structural*

10-2. Introduction. This chapter addresses the integration of HEMP/TEMPEST protection with other engineering requirements. In general, HEMP/TEMPEST protection does not conflict with other considerations of normal engineering construction. Certain critical interfaces require definition. There are nine major interfaces for HEMP/TEMPEST protection, which will be discussed in three groups due to their interrelated purposes. The interfaces include--

- a. Protection systems--group 1.
 - (1) Lightning protection.
 - (2) EMC/EMI protection.
 - (3) Physical security.
- b. Internal systems--group 2.
 - (1) Safety/fire protection.

EP 1110-3-2
31 Dec 90

(2) Grounding and bonding.

(3) Corrosion.

c. Environmental systems--group 3.

(1) Thermal expansion/contraction.

(2) Vibration/noise.

(3) Shock/ground motion.

10-3. Protection system integration. Most HEMP- and TEMPEST-protected facilities are also protected in some fashion for lightning, EMC/EMI, and physical security. Each of these considerations entails a protective system that must be coordinated with the HEMP and TEMPEST system for compatibility.

a. Electromagnetic compatibility/interference. HEMP, TEMPEST, and EMC/EMI protection are compatible. HEMP and TEMPEST protection often provide EMI protection as a secondary effect of their shielding. While the three do not conflict, in general, HEMP and/or TEMPEST cannot be seen as a solution to EMC/EMI protection. EMC and EMI problems must be addressed carefully as with any normal facility. There are some indications that EMP high-power filters can cause harmonic distortions that can affect certain communication systems (LF timing sequences). Also harmonic distortion feedback from equipment can destroy filters. Thus, it is important to fully analyze the entire system EMC.

b. Lightning. In general, lightning has a much slower rise time, higher input power, and narrower frequency impact than HEMP. Lightning protection is straightforward and well defined. The only impact of lightning protection to the HEMP system is the analysis of synergistic nonlinear effects due to HEMP and lightning ESAs. Any analysis of protection from surge currents on incoming power and communication lines due to HEMP must include an examination of lightning protection equipment.

c. Physical security. Physical security usually includes camera surveillance, sensor devices, cypher locks, personnel bars, and alarms. The only integration required is that no physical security device compromises the HEMP or TEMPEST shield. This means that camera, sensor, and alarm wires should be fiber optic in WBC where they penetrate the shield and that cypher locks should be placed on a separate door located outside the shielded door in a double door arrangement so as to not compromise the shield door. Personnel entry bar devices also should not be mounted in a way that compromises the shield.

10-4. Internal systems. Internal systems such as safety, fire, bonding, grounding, and corrosion protection are often driven by high authority. Despite the importance of these items, HEMP/TEMPEST survivability is by far a

more critical item. With slight alterations from normal procedure, these internal systems can function with full effectiveness with no impact on HEMP/TEMPEST shielding. The greatest problem in this area is generally due to a lack of knowledge, not from a lack of compatibility.

a. Safety and fire protection. Safety usually demands that all shielded rooms have two exits, despite the shielding rule of minimizing penetrations. Usually, the best answer is to include a shielded door with panic hardware interior to the shield on one door. This door should be used only in an emergency, ensuring minimum degradation with time. Also, fire safety may demand that sprinklers be included in all areas. It is usually accepted that waveguide entries can be exempted from this rule since they contain EMP doors on each side and are rendered useless by conductive sprinkler installation, unless it is carefully designed and installed.

b. Grounding and bonding. Grounding systems can be a major problem for HEMP/TEMPEST facilities if not carefully designed and maintained (including configuration control). A good grounding and bonding system provides maximum HEMP and lightning protection, EMC/EMI, and equipment and personnel safety. A poor system can adversely affect all of the aforementioned areas. In general, using the shield as an equipotential ground grid and then grounding the shield to the facility offers many benefits. The grounding system should be designed to allow for future system additions and internal transient control.

c. Corrosion. In general, corrosion systems are not incompatible with EMP shielding. Since EMP shields are usually steel, corrosion is an important consideration. This is especially true in roof areas. In many cases, water is retained in roofs to form standing pools on the steel shield roof. This situation will cause the roof shield to rust through. Waterproofing is thus critical on roof and floor areas. Cathodic protection systems also need to be designed carefully to avoid compromising the grounding protection.

10-5. Environmental systems. Certain environmental considerations can affect the integrity of the EMP shield. Though they can appear obvious, these considerations can and have caused major costs in repair and modification when they were underestimated.

a. Thermal expansion/contraction. EMP shielding is usually attached to the structural members of the facility. The exterior of a facility expands and contracts with temperature. Expansion joints in the facility allow for this natural flexing. The shield must also flex at these points. If not, either the shield or the facility structure will have to give, usually in an undesired way. This can cause cracks in the foundation, split seams in the shield, structural member stress, and other damage. The problem is costly to repair but simple to prevent. Prevention is simply a careful analysis to ensure that the facility and shield expansion/contraction measures are both appropriate and compatible.

EP 1110-3-2
31 Dec 90

b. Vibration and noise. Many facilities protected against HEMP require in-house generators and other equipment which cause high levels of noise and vibration. The steel shielding requires insulation and interior finish designed to dampen noise and vibration. Both insulation and acoustic finish must be installed in a way which does not compromise the shield. Heavy vibration can cause seams to crack, especially around penetrations. Such vibration should be dampened to prevent excessive degradation in the shield.

c. Shock and ground motion. The CONUS area is divided into seismic zones

to grade the scale and likelihood of ground motion. Areas that anticipate high levels of ground motion require special construction methods. Shielding in these areas must also include special treatment. This consists of shock isolators and frequent use of expansion/ flex joints to accommodate shield movement. These areas require access to the shield for repair and surveillance to a much higher degree than construction in normal areas. Shock treatment for blast effects must take the shield into consideration when designing blast survivability mechanisms. The shield must be able to move as projected without compromise.

10-6. General integration. When constructing a HEMP/ TEMPEST-protected facility, it is important to keep the HEMP/TEMPEST shielding system in proper context. HEMP/ TEMPEST shielding interfaces must be examined and given careful thought. Each major engineering area should be studied and analyzed.

a. Electrical. The effects of filter/ESA on the normal operating power system must be analyzed. The effect of protective devices on communication devices also must be checked. In general, adverse effects are minimal, but the questions must be answered in these areas. Fiber optic control lines in WBC should be used for automatic control systems.

b. Mechanical. Penetrations to the shield for utilities and HVAC must be welded. HEMP/TEMPEST shielding practices in no way conflict with mechanical needs, but they do require coordination. Utility lines must be capable of being welded or run through a WBC if nonconductive. HVAC ducts must be capable of being welded at the circumference and may require oversizing to compensate for honeycomb WBC filters installed in ducts.

c. Structural. Structural considerations are critical. Steel shielding must be supported, requiring strong structural framework. Expansion joints must be coordinated. Contact from shield to structure must not compromise the shield. The same is true for interior finish. Structural contact should be provided by spot-welding. On larger shield areas, structural strength to support shield weight must be planned carefully.

CHAPTER 11

DESIGN AND SPECIFICATION PROCESS

11-1. Outline. This chapter is organized as follows:

- 11-1. *Outline*
- 11-2. *Introduction*
 - a. *Shielding levels*
 - b. *Welded vs mechanical seams*
- 11-3. *Design approach*
 - a. *Exterior shield performance*
 - b. *Shield material and thickness*
 - c. *Necessary penetrations*
 - d. *Protecting penetrations*
 - e. *Test requirements*
 - f. *Configuration control*
 - g. *TEMPEST requirements*
- 11-4. *Typical design process*
 - a. *Specification development*
 - (1) *Applicable documentation*
 - (2) *HEMP protection system*
 - (3) *HEMP system components*
 - (4) *General requirements*
 - (5) *Submittals*
 - (6) *Quality assurance*
 - (7) *Delivery and storage of materials*
 - (8) *Materials and equipment*
 - (9) *Construction of the shield*
 - (10) *Shielded door installation*
 - (11) *Shield welding and brazing*
 - (12) *Welding procedure qualification*
 - (13) *Other welding qualifications*
 - (14) *Welding materials*
 - (15) *Welding operations*
 - (16) *Government inspection and tests*
 - (17) *In-process weld inspections*
 - (18) *Factory acceptance*
 - (19) *Final acceptance*
 - (20) *Quality control*
 - (21) *Supplemental data*
 - b. *Design drawings*
- 11-5. *General shield design problem areas*
 - a. *Waveguide-beyond-cutoff (WBC) penetrations*
 - (1) *Large diameter openings*
 - (2) *Welding honeycomb metal*
 - b. *Electrical filters*

EP 1110-3-2
31 Dec 90

- (1) *Unbalanced loads*
- (2) *Insulation breakdown*
- (3) *Improper placement*
- (4) *Oil insulation leakage*
- (5) *Improper sizing*
- c. *Radio-frequency (RF) doors*
 - (1) *Fingerstock doors*
 - (2) *Pneumatic doors*

11-2. Introduction.

a. *Shielding levels.* The design of TEMPEST- and HEMP-shielded facilities begins with an evaluation of mission requirements, equipment susceptibility, and threat predictions. The threat is usually a given factor. Equipment susceptibility is usually derived by standard assumptions, with mission requirements the decisive issue in shielding design. There are two types of shielding for HEMP/TEMPEST--high-level and low-level. In general, these can be classified as 100-decibel and 50-decibel shields. Often, HEMP shielding is required in a facility that also requires TEMPEST shielding. TEMPEST and HEMP should be considered together, with HEMP requirements taking precedence.

b. *Welded vs. mechanical seams.* Although many manufacturers advertise mechanical seam structures (bolted, riveted, etc.), these structures are strongly discouraged for a HEMP-shielded facility. If a facility mission is critical enough to warrant HEMP shielding, it needs steel sheets welded by the metal inert gas (MIG) process. Mechanical seam structures have a well documented history of poor maintainability, high repair cost, and poor overall performance compared with welded structures. Although the relative low cost of mechanical seam structures is very enticing given manufacturer claims of performance, practical experience has proven that these structures do not meet attenuation requirements above 50 decibels and, in the end, cost more than welded structures due to high life-cycle maintenance costs. Mechanical seam structures are advised for laboratory clean rooms, calibration, and low-level TEMPEST structures (see chapter 6), but not for HEMP shielding. This chapter discusses design of HEMP-shielded facilities, which may include TEMPEST requirements, and presents a typical design process.

11-3. *Design approach.* In designing a HEMP/TEMPEST facility, the designer must first consider the mission requirements in answering two critical questions. First, does the mission warrant the expense of HEMP shielding? If so, is it possible to isolate mission-essential/TEMPEST equipment and shield it on a component basis, or is it more economical or realistic to shield the entire facility? Once these two questions are answered, the design process is relatively straightforward. In almost all cases where HEMP shielding is required, facility shielding is the more cost-effective and intelligent choice since it maximizes flexibility for future requirements. If either component or facility shielding is chosen, the steps are the same except that one process addresses the entire facility and the other addresses each critical component separately up to some interface.

EP 1110-3-2

31 Dec 90

a. Exterior shield performance. Determine exterior shield performance in terms of decibels of attenuation of outside environment (threat) to interior environment. Generally, the decibel level is as previously stated--100 decibels for high-level and 50 decibels for low-level shielding when equipment to be protected is robust. If the zonal concept is used (nested shield areas), this is an iterative process.

b. Shield material and thickness. Determine the shield material and its thickness to meet the attenuation requirements (usually 10 to 12 gauge steel). Develop seam-fastening methods (shall be by inert GMAW steel for facilities). Consideration should be given to fabrication difficulties, especially for thin metal sheets.

c. Necessary penetrations. Develop a list of necessary penetrations to the shield for personnel entry, power and utilities, ventilation, and communication and control lines. Once the list is compiled, it shall be checked carefully to minimize penetrations when possible.

d. Protecting penetrations. Develop a method for protecting each penetration to meet attenuation requirements. It is desirable to provide a penetration entry room (PER) or vault to consolidate all or most penetrations into one area (discussed in detail later).

e. Test requirements. Develop quality assurance (QA) and acceptance testing requirements for construction, and evaluate hardness maintenance/hardness surveillance (HM/HS) requirements for the testing devices emplaced.

f. Configuration control. Develop a method for configuration control of the design penetrations. Consider special problems such as shield expansion, uninterruptible power supply (UPS), backup generators, and other facility-specific items.

g. TEMPEST requirements. Ensure that the shield confines all potential compromising TEMPEST emanations and contains all RED equipment.

11-4. Typical design process. The design process consists of developing design drawings and specifications. These documents are meant to be complementary, but the specifications will always take precedence over drawings. To best define this process, an example design for a standard HEMP protection system will be developed step by step. The example is for a 100-decibel welded shield only. If TEMPEST protection is required, these specifications will require appropriate modification.

a. Specification development.

EF 1110-3-2
31 Dec 90

(1) Applicable documentation. Normally, several publications will apply to the project. The following are examples of those that might be included:

(a) American Society for Testing Materials (ASTM) standards on steel such as:

- A 36-81A, Structural Steel
- A 366-72, Steel
- A 569-72, Steel

(b) American Institute of Steel Construction (AISC) publications such as the Specification for Design, Fabrication, and Erection of Structural Steel for Buildings (November 1, 1978).

(c) American National Standards Institute (ANSI) publications such as Z49.1, 1973 Safety in Welding and Cutting.

(d) American Welding Society (AWS) publications such as:

- A2.4-79, Symbols for Welding
- A3.080, Welding Terms
- D1.1-83, Structural Welding Code - Sheet Steel
- AWS A5.18, Steel Carbon Filler Metals for Gas Shielded ARC

Welding

(e) Military Standards are very important such as:

- MIL-STD-22, Weld Joint Design
- MIL-STD-188/124, Grounding, Bonding, and Shielding for Commo

Systems

- MIL-STD-202, Test Methods
- MIL-STD-220, RF Filter Testing
- MIL-STD-248, Welder Qualification Test
- MIL-STD-285, Electromagnetic Shield Testing
- MIL-STD-454, Requirements for Electrical Equipment
- MIL-STD-461, Susceptibility and EMI Control
- MIL-STD-1261, Welding Procedures for Steel

(f) Military Specifications are also critical; for example:

- MIL-F-15733, Filters, RF Interference
- MIL-B-5087, Bonding Electrical Systems
- MIL-W-8611, Welding, Metal Arc
- MIL-T-10727, Tin Plating of Metal.

(g) Some Federal Specifications may be helpful such as QQ-C-533, which covers the copper strips used in grounding, and HW-C-581, which covers steel conduit. In addition, MIL-HDBK-419 could be referenced.

(h) The National Fire Protection Association (NFPA) Publication 70-1984, National Electric Code, is mandatory.

EP 1110-3-2
31 Dec 90

(i) Finally, Institute of Electrical and Electronic Engineers (IEEE) Standard No. 142-1972, Grounding Practices for Power Systems, is usually needed.

(2) HEMP protection system. The three vital requirements are--

(a) A brief discussion of what HEMP is, why it is critical, to what extent the QA portion is vital, and how the HEMP requirements take precedence over all others.

(b) The HEMP performance requirement for the facility.

(c) A statement that no penetrations will exist except those on the penetration schedule included in the drawings without written approval of the contracting officer (CO).

(3) HEMP system components.

(a) Shield. The shield thickness, the ASTM Standard (usually A36), and the fact that the welding procedures shall conform to this section are given.

(b) Penetration. This paragraph usually discusses the fact that all penetrations will be treated and that no penetrations are allowed other than those listed on the penetration schedule without written CO approval. This paragraph also explains how penetrations will be highlighted on the drawings (stars) and that any accidental penetrations will be repaired at no expense to the Government.

(c) Doors. This paragraph briefly covers the doors, usually stating that they will be complete assemblies including frame and hardware. It is also usually mentioned that doors will be welded in place in conformance with this section, and any interlocking doors are covered here as well. Since a separate paragraph covers doors in detail, it is usually referenced here.

(d) Waveguide-beyond-cutoff (WBC) penetrations. This paragraph defines the maximum length-to-diameter ratio (5 to 1 for 100 decibels and the maximum allowable diameter (6 inches for 500 megahertz) (10 centimeters for 1 gigahertz and 1 centimeter for 10 gigahertz when there is a TEMPEST requirement). It generally mentions that all WBC penetrations for utilities will conform to requirements and references the paragraph that discusses WBC penetrations in detail.

(e) Pipe penetrations. This paragraph usually says that all pipe penetrations will be welded to the shield at the circumference as shown in drawings and not exceed the maximum allowable diameter (6 inches for 500 megahertz) (10 centimeters for 1 gigahertz and 1 centimeter for 10 gigahertz when there is a TEMPEST requirement).

EP 1110-3-2
31 Dec 90

(f) Electrical filters. This paragraph usually says that all power, communication, and control/signal lines other than fiber optic penetrating the shield will be provided with filters. The paragraph that discusses these lines in detail is referenced.

(g) Surge arresters. This paragraph generally states that the arresters must be installed according to manufacturer specifications and that they must have short leads (to form a low impedance path to ground) to work best. It references the paragraph detailing this component.

(h) Grounding system. This paragraph basically states the importance of the grounding system to the proper function of the system and notes that it is critical to follow the drawing during installation.

(4) General requirements. This section generally covers areas that are not directly applicable to specific system components such as QA and coordination.

(a) Usually a standard products paragraph is included which basically says that the equipment will be new and produced by a manufacturer regularly engaged in this type of work. It states that strict conformance to this section will be required.

(b) Usually a standard compliance paragraph is included to state that Underwriters Laboratories (UL) and other accepted labels will be accepted as proof of meeting standards already described. Otherwise, equipment not so labeled will be tested by an authorized agency and a written letter of certification provided.

(c) Another paragraph will state the contractor is responsible for integrating the shield system into the overall facility as shown on the drawings and for meeting this section of the specification exactly.

(d) A critical statement usually is included which is vital in avoiding the selection of unqualified AEs. It states that the system shall be provided by a firm regularly employed in this type of construction on an equal scale which has successfully completed several similar facilities. The CO may reject any proposed supplier or installer who cannot show documented evidence of these qualifications to the COs satisfaction. Finally, all work on the shield shall be under the supervision of competent, experienced HEMP shielding personnel.

(e) Another critical paragraph is that of coordination, which basically states that the contractor is responsible for ensuring that all disciplines realize the importance of the shielding and do not cause unauthorized penetrations to the shield. It also states that the contractor is responsible for repair of any compromise to the shield and must coordinate and submit in writing to the CO any changes to the HEMP system design.

(f) The next paragraph usually addresses the protection of materials from weather and corrosion.

(g) The last paragraph of this subsection states that the contractor is responsible for all testing--both QA and acceptance--and references the paragraphs that describe them in detail.

(5) Submittals. This section details the submittals required on a HEMP project.

(a) Manufacturer certificate. This paragraph generally states that the contractor shall submit certificates of compliance for all materials. Specifically included are--

- Shield: all steel and weld materials.
- Doors: certified test results, materials, and O&M data.
- WBCs: certified test results.
- Filters and surge arresters: certified test results.

(b) Shop drawings. This requirement is vital since it requires a complete list of equipment and materials, including manufacturers' literature, catalog cuts, and installation details. Shop drawings should show the sequence of shield construction; sizes, arrangement, and method of fabrication and installation; equipment layout; and details that prove the integrity of the shield as a complete system. Typical details will be provided that clearly show how the shielding effectiveness is maintained. Examples are--

- Shield. Details will be provided that display the locations of floor anchors, elevations, joint connections, types of welds, assembly and erection structural ties between shielding and building structure, connection to shield supports, and anchorage.
- Ground system. Connection details of the grounding system and shield will be given.
- Shielded doors. Manufacturer drawings showing the method of construction, attachment to shield, and control systems will be provided.
- WBCs. The size of opening, welding method, length of WBC, and attachment to shield will be shown.
- Filters and surge arresters. Manufacturer's drawings for enclosure, closure gaskets, and installation of components will be provided. Shop drawings will depict the location of the enclosure, method of attachment to the shield, conduit, manufacturer's data, and specifications for filters and surge arresters.

(c) Quality assurance (QA) plan. This section normally includes as a minimum--

- The contractor's organization plan showing how QA integrates with job-site management.
- Names, positions, and qualifications of all QA personnel and their responsibilities.

EP 1110-3-2

31 Dec 90

- Written proof of the authority vested in each individual or agency, including testing laboratories hired for the QA. A copy shall be included in the contractor's plan.

- The methods to be employed in daily inspection and testing.

- A sample format of the contractor's daily QA report. Specific test report forms shall be submitted for approval at least 10 days before the first use. Legible copies of the daily inspection reports shall be maintained by the contractor onsite at all times. The original copies of the "construction QA report" shall be submitted to the CO on the work day following the date of the report period, along with other items as required to assure adequate QC. Results of all inspections and tests performed by the contractor in accordance with the technical provisions shall be attached to the daily construction QA report.

- The location and description of all testing facilities and equipment to be used onsite.

- Procedures for control, submittal, and checking of contractor documents as required.

(d) Test procedure. A detailed test plan/procedure must be approved by the CO for in-progress and final acceptance testing. Included should be identification of personnel, test equipment, test schedule, methods, specific test points, and frequencies. The test procedure should detail the method of implementation and application of the procedures to be performed as part of the in-progress and final acceptance testing to verify compliance with the specifications. Testing should not commence without the CO's approval of the test procedure. The test plan should include--

- Introduction and scope. (Statement of purpose and relation to shielding. List of all tests to be performed.)

- Applicable documents. (Military, company, other.)

- General. (Description of in-progress testing and when used. Description of MIL-STD-285 acceptance testing and when used. Calibration method for equipment.)

- Test procedure. (Block diagram of each setup. Equipment used in each test. Detailed test procedure showing placement and orientation of antennas or probes, test frequencies, test points, data to be recorded, units of measure, and success criteria.)

- Outline of test report.

(e) Qualification of welders. The contracting welders' qualifications must be defined. Welding should be performed only by welders certified in the required process (MIG for the shield). Prior to assigning welders for HEMP shield work, the contractor should provide names of candidates to be employed together in the process specified in AWS D1.1 and D1.3 as required by the CO. It is vital that this paragraph state that the contractor shall submit identifying stenciled test specimens made by an operator whose workmanship is subject to question. Further, it will note that the welder must be retested and recertified at no cost to the Government. It is also critical for this paragraph to state that any defective weld that

compromises shielding effectiveness shall be ground out and properly rewelded. Other measurements and tests of welder capability are also recommended for inclusion here.

(6) Quality assurance. This section should state that the contractor is responsible for all in-progress testing of shield welds and HEMP protection devices as required and that all deficiencies will be corrected at no cost to the Government.

(7) Delivery and storage of materials. These requirements should be described briefly in terms of ensuring no damage to components, areas not approved for storage, and repair at no cost to the Government.

(8) Materials and equipment. These requirements should be covered in detail as a major part of the specification in a breakdown similar to that below.

(a) Shielding materials. The shield plate shall comply with ASTM A36 and be uncoated, degreased, and cleaned prior to installation. All sheets shall be flat or formed into appropriate shapes with no bends, kinks, or other deformities except those required by plans. Rusted or dirty steel shall not be installed. Steel sheets shall be sized for optimal fabrication and installation, and shall be a minimum of 3/16 inches thick.

(b) Weld filler material. This shall conform to AWS A5.18.

(c) Miscellaneous materials and parts. All materials necessary to complete each item, even though work is not definitely shown or specified, shall be included.

(d) Miscellaneous metal members. These shall conform to ASTM A36.

(e) Grounding. Any departures from the grounding system shown in contract drawings shall be submitted to the CO for approval. Grounding methods will comply with NFPA 7D, IEEE 142, and MIL-STD-188/124. Grounding guidance can be obtained from MIL-HBK-419.

(f) Material adjacencies. No materials shall be used in a combination that causes an electrolytic couple which creates unacceptable corrosion.

(g) Conductors. These shall be copper of a grade equal to standard commercial installation designated as being 98 percent conductive when annealed. Ground conductors for grids will be bare-sized as shown in drawings.

(h) Ground rods. The ground rods shall be copper-clad steel at least 3/4 inch in diameter and 10 feet long, exothermically welded to the grounding conductors and shield.

EP 1110-3-2
31 Dec 90

(i) Bonding of facility metal. Any metal that contacts the shield shall be bonded in accordance with MIL-B-5087, Class R System requirements and applicable safety practices.

(j) Penetrations. The contractor shall carefully determine all penetrations required in the shield. All electrical conduit penetrating the shield and within the PER and utility entry vault (UEV) shall be zinc-coated steel conduit (heavy metal rigid conduit all welded at points) as specified in Fed-Spec WW-C-581. Since zinc coating must be removed before welding, non-zinc coated conduit can be used where it will not be exposed to weather or corrosion. This section also should--

- Provide all WBC filters and penetration protection devices necessary to meet the specified attenuation.

- State that interfaces between trades (electrical, mechanical, plumbing, etc.) such as penetrations of the shield shall be coordinated to precisely match and maintain shield integrity.

- State that the finished facility shall not contain any unauthorized penetrations to the shield not shown on the approved drawings and penetration list. The contractor shall be responsible for warning all trades against unauthorized penetrations. Any repair or modification necessary as a result of unauthorized penetrations will be the responsibility of the contractor at no cost to the Government.

(k) RF shielded doors. This section shall state that--

- Doors should have attenuation of at least 10dB higher than the facility because doors degrade quickly.

- Doors shall be furnished by a firm regularly employed in the successful manufacture of similar products and shall duplicate assemblies that have had a proven satisfactory use over 2 years.

- The contractor shall submit test results proving that the doors shall meet the attenuation requirements over their life expectancy. However, these documents shall not relieve the contractor of onsite and acceptance testing. Shielding attenuation shall meet the requirements of NSA 65-6.

- RF seals, gaskets, and compact surfaces shall be permanently protected against physical damage by the shape of the jamb. They shall be readily replaceable without special tools.

- Frequency of operation shall be continuous. All components and assembly of door shall be of strength and size to function properly through 50,000 cycles of usage.

- Door material, including all components and assembly, shall conform to ASTM A 366 or A 569 for steel and be stretcher-leveled. Minimum thickness is 10 gauge.

- RF fingerstock for shielded doors shall be double-row conforming to Fed-Spec QQ-C-533 and installed around the periphery of the door and/or frame. The fingerstock shall use an extruded channel containing a recess into which two sets of beryllium copper contact fingers are fitted. The fingerstock shall be easily removable without special tools. The door

EP 1110-3-2
31 Dec 90

edge shall use a knife edge to mate to the fingerstock in such a way that optimal conductivity is obtained and attenuation requirements are met.

- All doors shall have suitable three-point latching mechanisms that provide proper compressive force for the RF seal through fingerstock. All latching shall be by roller bar system. All doors shall have three well balanced ball bearing or adjustable radial thrust bearing hinges.

- Threshold protectors shall be provided as ramps covering the knife edge for moving heavy equipment through RFI doors.

- Door interlocks shall be developed so that only one door can open at once.

(l) Waveguide-beyond-cutoff. Vents and panels shall provide the specified attenuation when installed in the shield configuration. Construction of WBC shall be according to drawings, with no WBC entry exceeding 6 inches (10 centimeters or 1 centimeter if there is a TEMPEST requirement) in diameter and a ratio of 5 length to 1 diameter. The WBC 5-to-1 length shall not be broken by drill holes, joints, or other openings from the point at which it enters the shield. Honeycomb vents (stacked WBC) shall be used for large airflow areas. A maximum of 4 inch squares brazed or soldered into a 1/4-inch metal frame by brazing or welding is permitted with a flange plate at least 6 inches wide. The flange plate serves as an insulator to weld the WBC to the shield without melting the solder or brazing the panel. Such WBC panels will be covered to protect against insect or bird invasion as required.

(m) Electrical filters and surge arresters. These devices shall be installed on all power, communication, signal, and control hardware penetrating the shield. Many manufacturers offer these devices. A minimum set of specifications to be met will follow in this section. Ground lengths shall be minimized for all filter/surge arrester installations. Also state that--

- Each filter unit shall be capable of being installed individually and shall include one filter for each phase and neutral wire for power lines or one filter for each conductive line or pair for communications and control lines.

- Filter units shall be provided in RF-modified NEMA type 1 enclosures made of not less than 14-gauge steel with welded seams. The enclosures shall be galvanized or electroplated after fabrication and welding, or the enclosure shall be finished with a corrosion-inhibiting primer and two coats of enamel. The enclosure will be RF-tight, 100 decibels from 14 kilohertz to 500 megahertz (both compartments). For TEMPEST protection, frequency requirement is 14 kilohertz to 1 gigahertz or 10 gigahertz.

- The power or control/signal input terminal compartment shall be separated from the power or control/signal output compartment by a solid steel barrier plate of the same gauge as the filter unit enclosure compartment extending across the width of the enclosure to form a 100-decibel barrier from 14 kilohertz to 500 megahertz. For TEMPEST protection, frequency requirement is 14 kilohertz to 1 gigahertz or 10 gigahertz. The output

EP 1110-3-2
31 Dec 90

compartment shall house the individual power line filters and the output terminals of the filter.

- The input terminal end of the individual filter case shall be attached to the RF barrier plate between two compartments to provide attenuation in accordance with NSA 65-6. The input terminals of the filters shall project through openings in the RF barrier into the input terminal compartment. The case of each filter shall be attached to the enclosure to prevent stress from being applied to the RF seal between the case and the RF barrier plate.

- The output and input compartments shall have no knockouts; weld conduits shall be welded to enclosures at the circumference.

- Access shall be from the front of the enclosure. The access opening for the load terminal compartment shall provide clear access to the filter input specified herein. The power output compartment opening shall provide clear access to the filter output terminals and the stand-off insulator terminals or insulated terminal blocks. It shall also allow easy removal of the individual filters from the enclosure. Two access cover plates shall be provided. One plate shall cover the access opening to the power input terminal compartment only and when secured in place shall provide an RF-tight seal with the compartment it covers. The second access cover plate shall cover the power output compartment only. RF gaskets shall be provided for both terminal compartment cover plates. The cover plates shall be secured with bolts having a maximum spacing of 3 inches. Access cover plates shall be made of not less than 14-gauge steel and the finish, except for bare-metal mating surfaces, shall be the same as specified for the enclosure. Plates shall be attached so as to be easily removed and replaced. Access cover plates should have folded edges to reduce uneven compression of the cover gaskets. Access panel retaining bolt torque shall provide 25 percent compression of the gasket over its entire contact surface (approximately 30 pounds per linear inch of gasket). Alternately, 0.094-inch-thick spacers may be used to provide proper gasket compression. All gasket contact areas shall be tin-plated per MIL-T-10727.

- Both terminal compartments shall provide an attenuation of not less than 100 decibels to radiated RF energy from 14 kilohertz to 500 megahertz with the individual filters mounted and the access cover plates attached.

- Individual filters shall be sealed in a steel case. The filter shall be sealed with an impregnating or potting compound meeting the requirements of MIL-F-15733 and having a flashpoint for operating temperature range B as defined in Table VIII of MIL-F-15733. After the filter is filled with an impregnating or encapsulating compound, the seams shall be welded. When a solid potting compound is used to fill the filters, the filters may be mechanically secured and sealed with solder. Hermetically sealed, impregnated capacitors shall be used, or the complete filter assembly shall be vacuum-impregnated. Individual power filter cases shall be made of not less than 14-gauge steel and corrosion-resistant primer and two coats of finish enamel. When enamel finishes are used, clean and free grounding surfaces of paint and/or insulating material.

EP 1110-3-2
31 Dec 90

- Provide the manufacturer's nameplate on each filter enclosure stating the filter's rated current, rated voltage, operating frequency, number of phases, lines or pairs for which it is designed, manufacturer's name, total filter unit weight, and model number. The nameplate shall be mounted on the filter enclosure to be visible after installation without removing cover plates or disturbing the interior parts or wiring. Each individual filter case shall be marked with the rated current, rated voltage, manufacturer's name, type of impregnating or potting compound, operating frequency, and model number. In addition, individual filter cases and the filter enclosure shall be durably marked by the manufacturer with the following statement: "Warning: Before working on filters, terminals must be grounded to ensure discharge of capacitors." Nameplates and warning labels shall be attached with epoxy. Each filter enclosure and each filter within the enclosure shall be numbered and recorded on the drawings for ease of location.

(n) Penetrator vault treatments. These are usually covered as follows--

- All conductive penetrators such as pipes and shielded cable must be treated as per MIL-STD-188/124 in the entry vault area. All conductive cable shields/sheaths must be grounded or be circumferentially bonded to the PER entry panel in the vault area as they enter the PER area.

- Where shielded cables are terminated in connectors on the PER entry panel, the cable shield must terminate at the connector and not be carried through the entry panel via a connector pin.

(o) Waveguides. Waveguide penetrations shall enter the facility at the PER entry panel. Waveguides will be peripherally welded or brazed to the communication vault side of the entry panel. All mechanical fasteners that penetrate the entry panel shall be circumferentially welded or brazed.

(p) Fiber optic cables. Fiber optic cables shall have no conductive strength members or vapor barriers. They shall enter the facility through the PER via conduit or pipe that is circumferentially welded to the entry panel and the back shield, thus effecting a WBC. The fiber optic conduits shall be identified at the shield and backshield penetrations and marked with notices prohibiting their use for anything other than fiber optic cables.

(9) Construction of the shield. This section usually covers the actual construction as follows:

(a) Workmanship. Metal work for the shield shall be formed to the correct shapes with sharp lines, angles and curves, and finished in accordance with approved shop drawings and samples. Welding of shielding liner shall conform to the requirements of this section. The mating surfaces of materials to be welded shall be clean and free of rust, scales, oil, and other deleterious materials. All exposed surfaces shall have a smooth finish. Steel plates shall be placed in a straight line with true level and joints.

EP 1110-3-2
31 Dec 90

(b) Sequence of installation. The basic design of this project assumes installation of the floor shield prior to erection of the structural system. The contractor may, as an option, choose to erect the structure first and install the floor shield later in the project. Should this option be selected, the contractor will so indicate to the Government and ensure that the required shop drawings and erection details clearly indicate the methods to be used to ensure shield integrity under all column and other structural members. All shielding components must be installed and approved in final inspection prior to construction of any features that would limit access for repairs to the shield.

(c) Placement of floor shield. Floor shield placement shall not begin until at least 14 days after the floor slab is poured and the Government has approved all required submittals.

(d) Placement of overslab. Approval of the CO's representative is required prior to pouring slab over any portion of the floor shield. Both visual and shielded-enclosure-leak-detection-system (SELDS) testing of shielded area to be covered must be completed, any defects repaired and retested, and full test results supplied to the CO prior to pouring the overslab.

(e) Penetration entry rooms. The PERs for the terminal equipment building and generator building provide a location for treatment of penetrations of driven conductors and for placement of in-vault treatments. The outer wall and floor surfaces of the PERs serve as the entry panel. The entry panel shall be constructed of 1/4-inch-thick ASTM A 36 steel plate welded in the same manner as the facility shield. The backs, or inner, walls of the PERs (backshields) shall be constructed of the same material as the facility shield. Filter enclosures for treatment of electrical penetrations shall be circumferentially welded to the inner surface of the entry panel. RFI-tight construction practices as described in this section must be exercised in the PERs--particularly for conduit and piping runs. This treatment requires heavy metal rigid welded conduit.

(f) Control of warping. Warping of steel shielding plates during installation and welding shall be kept to a minimum. Embeds and drive pins may be employed to hold plates in place during welding. Other techniques also may be employed to reduce warpage such as skip welding. However, when welding is complete, full penetration welds shall be used and drive pins shall be circumferentially welded.

(g) Repair of warped floor shield. With the exception of floor shield plates under concrete block walls, all steel floor shield plates that have a warp with an amplitude greater than 3/4 inch or a void longer than 3 feet between the underside of the plate and the concrete slab shall be cut out and replaced with new steel plate which will lie flat within these tolerances after all welding has been completed. The floor shield plates must lie flat

EP 1110-3-2
31 Dec 90

and bear continuously on the concrete leveling slab under all concrete block walls.

(10) Shielded door installation. This part is generally defined as follows. Door assemblies shall be welded to the shield in accordance with the manufacturer's installation instructions and approved shop drawings. Care shall be taken during installation to prevent damage, especially to fingerstock and RF gaskets. Doors, frames, thresholds, and associated hardware shall be furnished as preassembled matched units, each of which is to remain sealed until the installation has been accepted by the manufacturer's erection engineer and the CO. Each unit shall be installed in its respective door opening in accordance with the door manufacturer's instructions. Alignment shall be maintained within the tolerances established by the door manufacturer.

(a) Supervision. The door manufacturer's representative shall supervise the installation and checking of door assemblies.

(b) Post-installation protection. During the construction phase, the opening and closing of doors shall be kept to a minimum in order to limit wear on the door components, particularly the contact surfaces. The contractor shall plan his operations to keep the doors in a permanently open position with protection over sensitive components during all construction activities. When construction in the affected rooms has been completed, doors shall be locked in the closed position. All components that sustained damage during the construction phase shall be replaced at no cost to the Government. Temporary covers of not less than 5/8-inch plywood shall be secured to protect exposed RF barrier contactors from physical damage. Easily removable masking or strippable coatings shall be applied over contact surfaces to prevent soiling and corrosion.

(11) Shield welding and brazing. These skills are vital in attaining good attenuation in shielding. This section should be addressed similar to the following example.

(a) Location and types of welds. Weldments critical to the achievement of shielding effectiveness for the facility are shown in the drawings (see para b below). Shield welds shall be performed in the manner shown in the drawings using a GMAW (sometimes referred to as MIG) process in accordance with MIL-W-8611 and MIL-STD-1261. However, it should be noted that the term "critical" shall be used as defined above. The welding procedure and welding operator performance shall be qualified using MIL-STD-248 and shall comply with the Structural Welding Code of the American Welding Society. Where both structural integrity and shielding quality are required for a given weldment, both criteria shall be met simultaneously. Where not otherwise specified in this document, welded joint design shall follow MIL-STD-22. These joint design restrictions may be relaxed if it can be shown that shielding quality will not be degraded. All brazing shall conform to the

EP 1110-3-2
31 Dec 90

above documents, where practical, and shall also conform to requirement 59 of MIL-STD-454.

(b) Weld quality. The general quality of weldments shall be such that no gaps, burn-throughs, holes, cracks, bubbles, wormholes, undercuts inclusions or porosity is present. Fillet welds shall be heavy and oversized with a weldment thickness of not less than 3/16 inch and width of not less than 3/8 inch. Unless otherwise specified, all shield welds shall be continuous (or circumferential or peripheral) with no metal discontinuities allowed.

(12) Welding procedure qualification. This section should read substantially as follows:

(a) General. Each contractor to perform welding shall record in detail and shall qualify the welding procedure specification for any welding procedure that will be followed in making weldments. Qualification of welding procedures shall be in conformance with the applicable requirements of AWS D1.1, AWS D1.3, and as specified herein.

(b) Approval. Copies of the welding procedure specification and procedure qualification test results for each type of welding that requires procedure qualification shall be submitted for approval. Approval of any procedure, however, will not relieve the contractor of the sole responsibility for producing a finished structure meeting all requirements of these specifications. Welding procedure specifications shall be identified individually and shall be referenced on the shop drawings and erection drawings.

(c) Retests. If procedure qualification tests fail to meet the requirements of AWS D1.1, the welding procedure will not be approved, and the procedure specification shall be revised and requalified; or, at the contractor's option, retesting may be performed. If the welding procedure is qualified through retesting, all test results, including those of test welds that failed to meet the requirements, shall be submitted with the welding procedure.

(13) Other welding qualifications. This section usually includes the following requirements:

(a) General. Each welder, welding operator, and tacker assigned to work on this contract shall be qualified in accordance with the applicable requirements of AWS D1.1, AWS D1.3, and as specified herein. Welders, welding operators, and tackers who make acceptable procedure qualification test welds will be considered qualified for the welding procedure used.

(b) Certificates. Prior to assigning any welder, welding operator, or tacker to work under this contract, the contractor shall provide the CO

with the names of the welders, welding operators, and tackers to be employed on the work, together with certification that each individual is qualified as specified herein. The certification shall state the type of welding and positions for which the worker is qualified, the code and procedure under which he or she is qualified, the date qualified, and the firm and individual certifying the qualification tests. The certification shall be kept on file and three copies shall be furnished to the CO. The certification shall be kept current for the duration of the contract.

(c) Identification. Each welder, welding operator, or tacker shall be assigned an identifying number, letter, or symbol which shall be used to identify all welds made by that person. For identification of welds, each welder, welding operator, or tacker shall apply his or her symbol adjacent to the weld using a rubber stamp or felt-tipped marker with waterproof ink or other methods that do not result in an indentation in the metal. Records shall be maintained indicating these locations. In the case of seam welds, the identifying mark shall be adjacent to the weld at 3-foot intervals. Identification using die stamps or electric etchers shall not be allowed.

(d) Renewal of qualification. Requalification of a welder or welding operator shall be required under any of the following conditions:

- The welder or welding operator has not used the specific welding process for which he or she is qualified for a period exceeding 6 months.

- There is a specific reason to question the welder's ability to make welds that meet the requirements of these specifications.

- The welder or welding operator was qualified by an employer other than those firms performing work under this contract and a qualification test has not been taken within the preceding 12 months. A tacker who passes the qualification test shall be considered eligible to perform tack welding indefinitely in the positions and with the processes for which he or she is qualified unless there is some specific reason to question this individual's ability. In the latter case, the tacker shall be required to pass the prescribed tack welding test.

(14) Welding materials. These requirements may be addressed in a single paragraph as follows: All items of equipment for welding, electrodes, welding wire, and fluxes shall be capable of producing satisfactory welds when used by a qualified welder or welding operator using qualified welding procedures. All welding materials shall comply with the applicable requirements of AWS D1.1 and AWS D1.3.

(15) Welding operations. Likewise, workmanship may be covered in a brief paragraph: Workmanship and techniques for welded construction shall be in conformance with the applicable requirements of the AISC Specification for the Design, Fabrication and Erection of Structural Steel for Buildings, and of AWS D1.1 and AWS D1.3. In case of conflict between AWS D1.1/D1.3 and the AISC specification, the requirements of AWS publications shall govern.

EP 1110-3-2
31 Dec 90

(16) Government inspection and tests. This paragraph gives the Government the right to test as it feels necessary: In addition to the inspection and tests performed by the contractor for quality control, the Government may perform inspection and testing for acceptance to the extent determined by the CO. The costs of such inspection and testing will be borne by the Government and the work may be performed by its own forces or under a separate contract for inspection and testing. The Government reserves the right to perform supplemental nondestructive and destructive tests to determine compliance with this section. The welding shall be subject to inspection and tests in the mill, shop, and field. Inspection and tests in the mill or shop will not relieve the contractor of the responsibility to furnish weldments of satisfactory quality. When material or workmanship does not conform to the requirements of this section, the Government reserves the right to reject either or both at any time before final acceptance of the structure containing the weldment.

(17) In-process weld inspections. These inspections are critical and should be defined similar to the following:

(a) Visual inspections. The welds shall be inspected visually. Defects uncovered shall be repaired and the area reinspected. All welds shall be 100 percent inspected.

(b) Weld test requirement. During construction, electromagnetic "sniffer" type tests shall be employed to inspect and ultimately assure quality welds. The test method to be employed is the shielded-enclosure-leak-detection-system (SELDS) or equivalent. This test measures normal magnetic fields resulting from an electromagnetic discontinuity or anomaly. The magnetic field probe will locate these anomalies by indicating a change in the meter reading accompanied by an audible tone or an increase in sound level as the probe passes over the discontinuity. The SELDS is to be used on all welds, including seams, patches, wall joints, and door frames. Testing, repair, and retesting shall continue until no anomalies are noted. Discontinuities found shall be marked for repair. All repaired areas shall be pretested for acceptability. Other information to include is--

- SELDS consists of two units, a generator and a small hand-held detector. The generator is connected directly to two opposite corners of the shielded area under test and the outer surface is excited with an RF current. When the sheath of RF current encounters a discontinuity such as a defective weld, a strong magnetic field is set up at right angles to the shield wall. The discontinuity is detected by a speaker, earphones, and/or an indicating meter.

- All welds in the total shielding system shall be 100 percent tested by the SELDS technique and all defects repaired prior to conducting the final acceptance tests. The CO shall be notified 3 days prior to SELDS testing so that Government witnesses can attend if desired.

- The floor shield shall be thoroughly SELDS tested and accepted by the CO prior to pouring the overslab. All penetrations shall be

EP 1110-3-2
31 Dec 90

in place and thoroughly SELDS tested. The CO shall be notified before the SELDS test is conducted on the floor.

(c) Corrections and repairs. When inspection or testing indicates defects in the weld joints, the welds shall be repaired by the shielding contractor using a qualified welder or welding operator. Corrections shall be in accordance with the applicable requirements of AWS D1.1, AWS D1.3, and as specified herein. All defects shall be marked clearly and conspicuously. Defects shall be repaired in accordance with approved procedures. Defects discovered between passes shall be repaired before additional weld material is deposited. Workmanship in the affected area shall be blended into the surrounding surface so as to avoid sharp notches, crevices, or corners. After a defect is thought to have been removed, and prior to rewelding, the area shall be examined by suitable methods to ensure that the defect has been eliminated. Repair welds shall be inspected and retested to the requirements for the original welds. Any indication of a defect shall be regarded as a defect unless reevaluation by nondestructive methods and/or by surface conditioning shows that no unacceptable defect is present.

(d) Covering of shielded work. In addition to the contractor's QA performance in terms of materials and workmanship, the contractor shall notify the CO 3 working days prior to covering or enclosing any shielding work. This notice will allow for any inspection of systems that the CO may wish to conduct and for adequate time to witness any covering or enclosing of the shielding work.

(e) Reports. Reports of daily testing shall be submitted to the CO within 3 working days. Each report shall include the method of testing, the equipment used, the location of the test, and results. A final report detailing in-progress testing shall be submitted in accordance with the format shown in (19)(h) below.

(18) Factory acceptance. Factory acceptance may be detailed as follows:

(a) General. All manufactured HEMP protection components shall successfully pass factory acceptance prior to their shipment to the site. These components include shielded doors, filters, ESAs, and WBC panels.

(b) Shielded doors. All RF-shielded doors shall be tested to show compliance with the requirements of this section, including attenuation. In addition, the following mechanical tests shall be performed--

- Swinging and sliding door static load test. The swinging leaf door shall be mounted and latched to its frame, then set down in a horizontal position so that the door will open downward and only the frame is rigidly and continuously supported from the bottom. A load of 40 pounds per square foot shall be applied uniformly over the entire surface of the door for at least 10 minutes. The door will not be acceptable if this test causes any breakage, failure, or permanent deformation that makes the clearance between door leaf and stops vary more than 1/16 inch.

EP 1110-3-2
31 Dec 90

Swinging door sag tests. The door and its frame shall be installed normally and opened 90 degrees. Two 50-pound weights, one on each side of the door, shall be suspended from the door within 5 inches of the outer edge for at least 10 minutes. The door will not be acceptable if this test causes any breakage, failure, or permanent deformation that makes the clearance between the door leaf and door frame vary more than 1/16 inch from its original dimension.

- Swinging and sliding door closure test. The door shall be operated for 100 complete open-close cycles. The door will not be acceptable if this test causes any breakage, failure, or permanent deformation that makes the clearance between door and door frame vary more than 1/16 inch from its original dimension.

(c) Filter insertion loss tests. All filters shall be tested at the factory for insertion loss in accordance with MIL-STD-220 under full load using modified buffer networks and shall provide 100 decibels of insertion loss under full load from 14 kilohertz to 500 megahertz (for TEMPEST requirement, frequency is 14 kilohertz to 1 gigahertz or 10 gigahertz). All power line filters shall also be tested for voltage drop not to exceed 2 percent under full load. Power filters must be operated under full load for 10 hours before testing. The increase in temperature of the outer case during this period must not exceed 40 degrees centigrade above the ambient temperature of the room. Filters shall be shipped after successful testing per above. Prior to installation, evidence that the filters being used were tested successfully shall be presented to the CO's representative. Furthermore, prior to installation, filters shall be examined to determine if any obvious damage occurred during shipment. Any damage that affects the filter's function shall be grounds for rejection of the filter. All filters must be installed prior to beginning the facility final acceptance testing.

(d) Filter enclosure tests. All installed filter enclosures shall be tested for 100 decibels attenuation from 14 kilohertz to 500 megahertz (for TEMPEST requirements, frequency is 14 kilohertz to 1 gigahertz or 10 gigahertz) in accordance with MIL-STD-285. Isolation from the filtered to the unfiltered side of the enclosure also shall be verified.

(e) Panels. Attenuation of premanufactured WBC panels shall be verified by factory test to be 100 decibels from 14 kilohertz to 500 megahertz (for TEMPEST requirements frequency is 14 kilohertz to 1 gigahertz or 10 gigahertz).

(f) Electrical surge arresters. All ESAs shall be factory-tested to show compliance with requirements of this section.

(19) Final acceptance. Requirements other than factory testing may be stated as follows.

(a) Acceptance test requirements. Upon completion of construction, including installation of all penetrations, penetration protection devices,

EP 1110-3-2
31 Dec 90

and successful in-progress testing of welds, the shielding system shall be tested to assure compliance with performance requirements of the contract specifications. Shielding effectiveness testing shall be in accordance with MIL-STD-285, modified as appropriate to accomplish the required tests. The purpose of this test is to ascertain the continuity and electromagnetic tightness of the shielding after construction. The measurements are designed to show that an electromagnetic defect-free enclosure is achieved.

(b) Test contractor requirements. Tests shall be performed by a qualified firm regularly engaged in the testing of welded shield enclosures. "Regularly engaged" is defined to mean that the testing firm has successfully performed MIL-STD-285 and "seam-sniffing" tests on similarly sized facilities at least twice in the 3-year period preceding award of the contract. All costs of tests are the responsibility of the contractor. Qualifications of the firm selected and the test methodology shall be submitted to the CO for approval within 30 days after receipt of notice to proceed.

(c) Test plan. The contractor shall provide a test plan for the CO's approval. The test plan shall include the qualifications of the firm proposed to perform the test as required in paragraph (b) above. The test plan shall also identify the test equipment to be used and its proposed configuration; the special-purpose support equipment required (scaffolds, cherry-pickers, etc.); and the safety approach that will be employed. Furthermore, the test grid shall be identified and the plan for correlating that grid to the structure shall be provided. In addition, a schedule of test events to include equipment delivery, calibration, layout of test points, and the testing activities, including plans for corrective action and retesting, shall be provided.

(d) Notice of tests. The CO shall be notified in writing 10 working days prior to test initiation.

(e) In-process testing. In-process testing and certification shall not demonstrate conformance to the specified attenuation levels. This conformance shall be demonstrated by final acceptance testing as specified below.

(f) Final acceptance testing. Final acceptance testing shall be conducted by the shielding contractor or independent testing laboratory in conformance with the procedures in MIL-STD-285. The test shall be witnessed by a CO representative. All necessary personnel and test equipment for performing tests required by this section shall be furnished by the contractor. Where structural conditions prohibit use of MIL-STD-285 procedures, testing shall be provided by use of the SELDS as described above. This procedure shall be used only as authorized and directed by the CO. Performance of the shielding system shall meet the requirements of NSA 65-6. Final acceptance tests shall be conducted around all doors and mechanical, electrical, and communications penetrations, in addition to weak points previously identified by SELDS and repaired under interim testing.

EP 1110-3-2
31 Dec 90

requirements. The final acceptance test instrumentation shall have the necessary sensitivity, power output, and quality for the required tests so that the combination of source gain and receive sensitivity will permit attenuation measurements at least 6 decibels greater than the limits specified in NSA 65-6. Also included in this section are--

- Test methodology. Antennas shall be oriented for maximum signal pickup. Each test point shall be probed for area of maximum leakage, such as all around door frames, accessible joints, filters, pipes, and air ducts. The magnitude and location of maximum signal levels emanating from the enclosure shall be determined for each accessible wall in at least two locations per wall, around the door, all penetrations, and all seams in the facility. Attenuation shall be measured in accordance with the guidance provided in NSA 65-6.

- Magnetic field tests. Attenuation of low-impedance (magnetic) fields shall be measured at 14 kilohertz, 250 kilohertz, and 5.0 megahertz.

- Plane wave tests. Attenuation of 377-ohm plane waves shall be measured at 100, 200, and 500 megahertz. For TEMPEST, also test at 1 gigahertz or 10 gigahertz.

(g) Corrections and repairs. Any defect in any part of the HEMP protective system discovered during final acceptance testing shall be corrected at contractor expense in accordance with the techniques and practices specified in this section. All costs to repair the shield and return the facility to finished design condition shall be borne by the contractor. Pretesting shall be accomplished as necessary to ensure that the complete structure meets the attenuation requirements of NSA 65-6 from 14 kilohertz to 500 megahertz (for TEMPEST requirements, frequency is 14 kilohertz to 1 gigahertz).

(h) Reports. Reports of final testing shall be submitted in triplicate to the CO. Each report shall describe the method of testing, equipment used, and location of tests. The report of final acceptance testing shall include--

- Cover page.
- Administrative data. This includes test performer, contract number, date of test, and authentication (contractor personnel responsible for performing the tests and any witnesses).
- Technical contents. This includes shielded facility description, nomenclature of measurement equipment, serial numbers of measurement equipment, date of last calibration of measurement equipment, type of test performed, measured level of reference measurements and ambient level at each frequency and test point, measured level of attenuation in decibels at each frequency and test point, limits at each test frequency and test point, frequencies of test, and location on the shielded enclosure of each test point.

- Conclusions. This section shall include the results of the tests in brief narrative form.

EP 1110-3-2
31 Dec 90

- Daily reports. Daily reports of the results of each individual test performed on each portion of the shielding system shall be submitted. The location of the area tested shall be identified clearly. Leaks detected during testing shall be identified with enough accuracy to permit relocation for testing in accordance with the final acceptance test procedures. Reports of daily testing and of final acceptance testing shall be submitted to the CO with the required certification by the testing agency representative or consultant.

(20) Quality control. This section is usually addressed with a standard paragraph as follows: "The contractor shall establish and maintain quality control to assure compliance with contract requirements and shall maintain records of his quality control for all construction operations required under this section. A copy of these records, as well as the records of corrective action taken, shall be furnished the Government as required in this specification."

(21) Supplemental data. Tables 11-1 through 11-6 and figure 11-1 are examples of supplemental data that could be included in the specifications.

b. Design drawings. The second part of a complete facility design package is the design drawings. Though the specifications take precedence, the drawings tend to be used much more often by contractors. The one critical element that the drawings must show is a completely sealed shield. Ideally, one would like to build a perfect shield without seams or penetrations. This is not possible. As a result, the drawings must show clearly how each type of seam and each penetration is protected. This level of illustration can only be accomplished with details that are of small enough scale to show singular protection devices. The checklist in figure 11-2 is provided as a recommended test for all HEMP drawings to pass.

11-5. General shield design problem areas. HEMP shield is a steel box welded at the seams. If holes must be drilled into it to use its inner space, some type of seal must be placed around the hole. The steel is usually 3/16 inch or thicker because it is very difficult to weld thinner material. There are only three types of penetrations allowed in a shield: WBC, electrical filters, and RF doors.

a. Waveguide-beyond-cutoff (WBC) penetrations. A WBC is basically a solid steel tube that dampens electromagnetic waves as they reflect off its sides. The tube must be unbroken for the proper length to dampen the required amount, such as 5 times the diameter for 100 decibels. Thus, a 2-inch hole must have an unbroken tube 10 inches long welded circumferentially (all around the pipe) to the shield. Also, to ensure that the WBC functions correctly, it cannot be more than a certain diameter or the electromagnetic waves will simply pass through it without rebounding and no dampening will occur. This maximum diameter is determined by the required frequency cutoff (usually 500 megahertz). A simple approximation to calculate this diameter is that it must be no greater than $6000/2$ divided by the upper protection frequency in

EP 1110-3-2
31 Dec 90

megahertz. Thus, for 500 megahertz, no diameter greater than 6 inches is allowed and no more than 3 inches for 1 gigahertz. WBCs encompass ventilation, exhausts, water/fuel pipes, fiber optic entries, and all other nonconductive openings. The typical problems found with WBCs are described below.

(1) Large diameter openings. The utility entry or exhaust is too large to meet maximum diameter rules and it is not feasible to use multiple WBCs due to possible backpressure or clogging. The solution is to use a 1/4-inch wire mesh and keep the pipe RFI tight for as long a length as possible. This solution should be used only where a solid argument can be made for not using the standard WBC arrangement.

(2) Welding honeycomb metal. The second problem is the welding emplacement of honeycomb WBC for ventilation. Since the honeycomb is brazed or soldered together, it may melt under welding. A heat sink consisting of 6 inches of steel frame should be enough to handle this problem.

b. Electrical filters. A filter consists of capacitors and inductors in a configuration that bleeds out EMP currents at unwanted frequencies. Generally, small communication and signal filters are well made and have no problems. Power-line filters are entirely different, however, and have many problems--especially the high-power type. High-power filters tend to have the problems described below.

(1) Unbalanced loads. Overheating due to unbalanced loads between phases which causes single filters to fail and can cascade power onto the remaining filters to cause complete destruction of the filter. The solution is to specify a load balance within 5 percent and have the filter designed so that any failure of one filter element causes the filter to short to ground and to drop offline, thus saving the remaining filters. This will not work with filters in parallel.

(2) Insulation breakdown. Insulation breakdown which causes a short to the filter casing and burns up the filter. The only solution to this problem is to rely on reputable filter manufacturers who understand complexities such as corona effects and other high-power phenomena.

(3) Improper placement. Installation of filters such that they are placed in the circuit backwards, causing failure of the filter and misplacement of the MOV behind the filter. The construction inspector therefore must have knowledge of proper filter emplacement. Also, symmetrical filters that will operate in any configuration should be used.

(4) Oil insulation leakage. Leakage of oil insulation into the filter case, causing filter failure. In general, it is best to avoid oil-filled filters or to carefully inspect them for leaks.

EP 1110-3-2
31 Dec 90

(5) Improper sizing. Failure to meet specified attenuation requirements.

c. Radio-frequency (RF) doors. There are two types of RF doors--fingerstock and pneumatic. RF doors are the single weakest link in the shielding system. They degrade faster and are abused and misused more than any other item. It is highly recommended that the major entry and exit for any HEMP facility use two interlocking RF fingerstock doors with a waveguide entry between them. This design prevents compromise when one door is open and provides dampening to make up for the degradation that is natural in RF doors. Other entry points should be used as infrequently as possible. Waveguide entry tunnels should be all-welded steel hallways approximately 50 feet long with no conductors in them. Lighting can be provided through WBCs in the tunnel ceiling. Doors should have regular O&M service to curtail degradation.

(1) Fingerstock doors. Double knife-edge RF fingerstock doors are the most dependable type on the market. They are recommended for all 100-decibel facilities as the main points of entry and other personnel access. Their main drawback is fingerstock damage. Good O&M and occasional testing are necessary to keep these doors in operation at the proper decibel level.

(2) Pneumatic doors. Pneumatic sliding doors are the second best entry method. When this type of door is working correctly, it surpasses the fingerstock door in attenuation. The problem with the pneumatic door is that it is composed of a complex mechanism of air bladders, pneumatic piping, and sensitive contact surfaces. These doors are subject to many breakdowns and long downtime because specially trained individuals and specialty parts are required for repair. Because of the likelihood of breakdown, this type of door is recommended only for seldom used cargo or other large entries. If it is used at the main entry point, a double door with waveguide tunnel between doors is required to provide protection when one door is down for repair.

EP 1110-3-2
31 Dec 90

Table 11-1. Power line surge arrester criteria.

Parameter	Requirement
277/480-V, 3-Phase, 4-Wire System	
Clamp voltage	Less than 1200 V with kV/nsec pulse slope
Power consumption	Less than 600 MW per phase (device only)
Extreme duty discharge capability	Greater than 65 kA (8x20 microsec* pulse, 0.65 Coulomb)
120/128-V, 3-Phase, 4-Wire System	
Clamping voltage	Less than 750 V with 10 kV/nsec pulse slope
Power consumption	Less than 200 MW per phase (device only)
Exreme duty discharge capability**	Greater than 25 kA (8x20 microsec* pulse, 0.25 (Coulomb)
Common to Both Systems	
Minimum operational life	200 operations with 10 kA, 8 x 20 microsec pulse
Operating temperature	-40 F to =140 F
Self-restoration time	Less than 10 msec
<p>*The first figure in the waveform is the 10 percent to 90 percent risetime. The second figure is the time to fall from peak value to 1/e, (approximately 0.368) times the peak value (e-fold time).</p> <p>**Where a lightning threat is applied, the extreme duty discharge capability should be increased to 65 kA, 0.65 Coulomb.</p>	

EP 1110-3-2
31 Dec 90

Table 11-2. Power line filter criteria.

Parameter	Requirement
Insertion loss	100 dB from 14 kHz to 500 MHz measured per MIL-STD-220A
Minimum life	15 years (150,000 hours)
Current overload capability	140% of rated current for 15 minutes, 200% for 1 minute, and 500% for 1 second per MIL-F-15733
Operating temperature range	Continuous operation from -55 C to +65 C per MIL-STD-202, method 108A, test condition H. Shall also withstand temperatures cycling as specified in MIL-STD-202, method 102, test condition D
Temperature rise	Less than 40 C for individual filters suspended in ambient air at 20 C
Inductor linearity	Better than +3% from no load to full load
Voltage drop (at operating frequency)	Not to exceed 2% of rated line voltage when fully loaded (resistive load)
Dielectric withstanding voltage	200% of rated voltage for 2 minutes as specified in MIL-STD-202, method 301
Terminal resistance to ground	Greater than 1.5 megaohm when measured per MIL-STD-202, method 302, test condition B
DC resistance	No greater than 5 milliohms as measured per MIL-STD-202, method 303
Maintainability	Individual filters shall be replaceable units and like filters shall be interchangeable

EP 1110-3-2
31 Dec 90

Table 11-3. Signal and control line protection: coaxial penetrations.

Data: 2 Mb/sec, 75 ohm

Surge Arrester

<u>Parameter</u>	<u>Requirement</u>
Clamp voltage	7 V +/- 0.5V
Maximum insertion loss	< 3 dB
Maximum peak pulse current; I_{pp}	139 A
Minimum operational life	2000 operations at I_{pp}

Filter

Impedance (in-band)	75 ohm +/- 1 ohm
Insertion loss (out of band)	100 dB 14 KHz - 500 MHz
Bandwidth (40 dB BW)/center	15%/2 MHz
Insertion loss (in-band)	< 3 dB

Data: RF 70 to 700 MHz, 50 ohm

<u>Parameter</u>	<u>Requirement</u>
DC breakdown voltage	200 +/- 50 V
Impulse current (max), I_C	10,000 A (8x20microsec waveform)
Impulse breakdown (max)	1000 V 1 kV/nsec)
Impedance	50 ohm +/- 1 ohm
Insertion loss	< .25 dB
Minimum operational life	10 pulse at $1/2 I_C$

Filter

Double band pass may be required. Further information is needed.

EP 1110-3-2
31 Dec 90

Table 11-4. Twisted shielded pair criteria.

Balanced Surge Arrester for All Twisted Pairs^{*}

<u>Parameter</u>	<u>Requirement</u>
DC breakdown voltage	300 V +/-50 V
Impulse current (max), I_C ^{**}	25 kA (8x20 microsec pulse shape)
Impulse breakdown (max) ^{**}	700 V (20 kV/microsec)
Balance (max)	10 ns firing
Minimum operation life	>50 pulse at 20 kA

Data: 10 Kb/sec and Voice Low-Pass Filter

Insertion loss (out of band)	100 dB (14 kHz - 500 MHz)
------------------------------	---------------------------

Data: 10 Kb/s < Rate < 56 Kb/s^{***}

<u>Parameter</u>	<u>Requirement</u>
Impedance (in-band)	100 ohms + 1 ohm
Insertion loss (out of band)	100 dB 14 KHZ - 500 MHZ
Bandwidth (40 dB BW)/center frequency (of)	15% of or as required
Insertion loss (in-band)	<3 dB

Twisted shielded pairs will have a 5-ohm 1-watt carbon composition resistor in series with each filter input, placed between the surge arrester and the filter input.

*Recommended Joslyn TRIGUARD Model 2022-24 or equivalent.

**To ground.

***Comment: specific line data rates must be defined. Custom filters may be required.

EP 1110-3-2
31 Dec 90

Table 11-5. Terminal protection device.

Parameter	Requirement	Type No.
Reverse standoff voltage	6 V	IN6036A
	12 V	IN6043A
Peak pulse power dissipation	1500 W	
Polarity	Bidirectional	
General semiconductors		TransZorb or equivalent.

Table 11-6. Shielding effectiveness check points.

<p> Joints between steel panels (roof and walls) </p>	<p> -Test every 3 feet for small facilities </p>
<p> Corner seams (walls to floor surfaces) </p>	<p> - Test every 3 feet for small facilities </p>
<p> Corners (intersection of 3 surfaces) </p>	<p> - Test all corners </p>
<p> Single doors (hinged) </p>	<p> - Test at each corner and midpoint of each side longer than 4 feet and at center </p>
<p> Sliding doors </p>	<p> - Test each separately at same test points as with single hinged doors </p>
<p> WBC vents and vent panels </p>	<p> - Test in center (on axis) for all sizes (including single), and at all four corners if 1 x 1 feet or larger, and at the midpoint of each side longer than 4 feet </p>
<p> All treated penetrations of shield (and entry panel and backshield) </p>	<p> - Test as close to "on-axis" as possible or orient for maximum signal </p>
<p> All other shield joints, seams or corners </p>	<p> - Test every 3 feet </p>

EP 1110-3-2
31 Dec 90

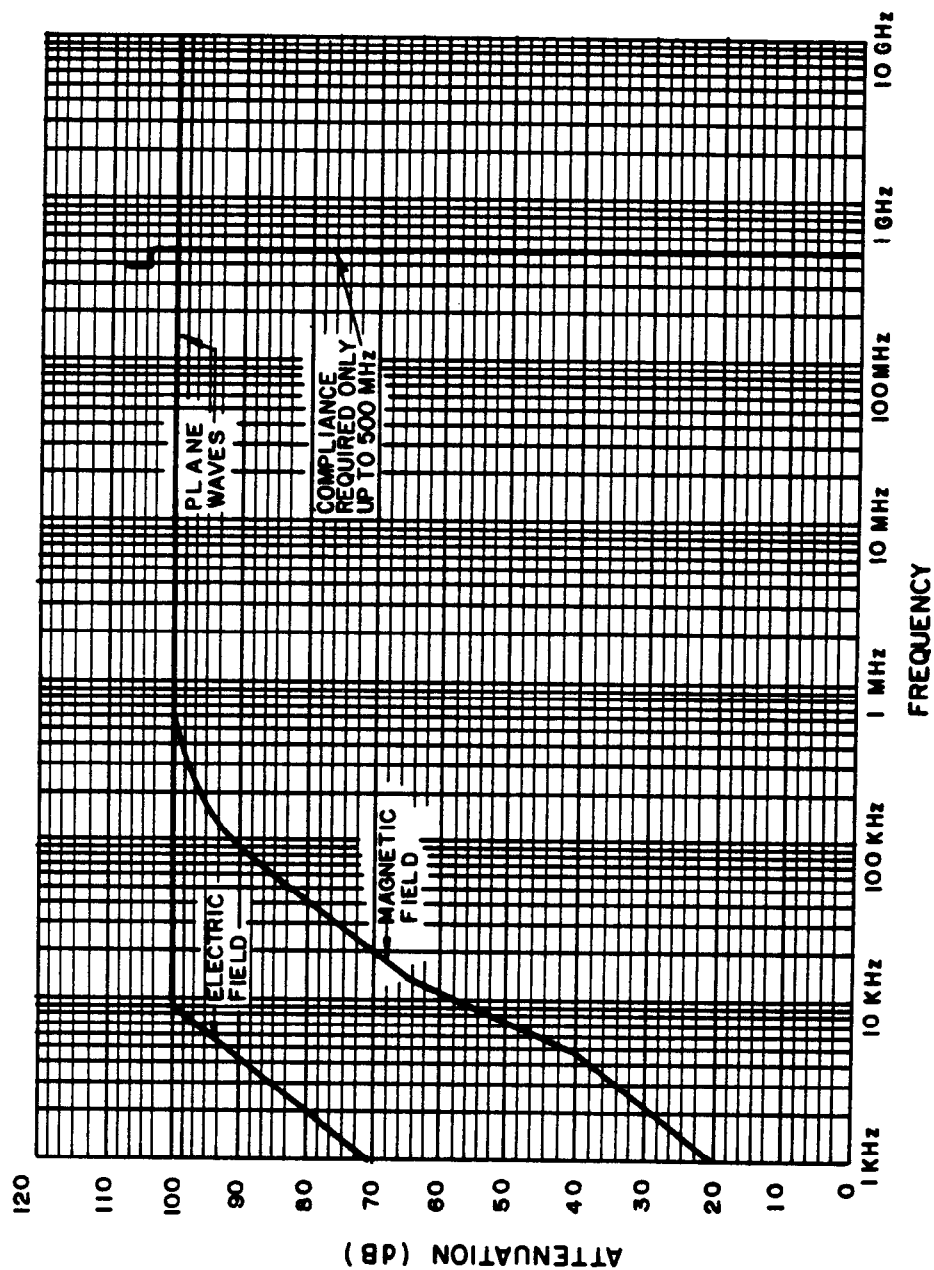


Figure 11-1. Required electromagnetic attenuation.

- A. Specifications and Review**
- 1. Shield**
- a. The level of shielding required is clearly stated in terms of decibels.
 - b. The shield material is clearly identified and meets the proper ASTM or equal qualifications.
 - c. The proper EMP hardness test is noted (MIL-STD-285, sniffer, and dipenetrant).
 - d. The methods of making seams and attaching the roof to walls and walls to floor are clearly defined.
 - e. The method of attachment for shield to structure is clearly defined.
 - f. QC and acceptance test procedures are required from the contractor as submittals to the Government.
 - g. The welding method is clearly defined and welding material and welder certification are identified.
- 2. Penetration protection**
- a. RF filters are clearly defined in terms of decibel protection and rating.
 - b. Electric surge arrester devices are clearly defined and properly specified for application.
 - c. Waveguide-below-cutoff devices are clearly defined and properly specified.
 - d. Utility penetrations are defined and treated properly.
 - e. RF doors are properly designed to provide the required protection.
 - f. Personnel entryways are defined properly in terms of interlocked doors and entryway waveguide.
 - g. Access covers/doors are proper.

Figure 11-2. Checklist for HEMP drawings. (sheet 1 of 3)

EP 1110-3-2
31 Dec 90

- h. The fiber optic entering the shield is protected by WBS and completely devoid of conductive strengthening wire.
- i. Conduits are clearly defined and properly joined.
- j. Filter enclosures are clearly defined and proper.
- k. Utility entry vault is clearly defined and proper.
- l. A statement is included covering the protection for doors/WBC/filters/and shield materials during construction.
- m. Any special certification required is noted.
- n. Grounding method is clearly defined and proper.
- o. A note covering construction changes and the care which must be taken to ensure no compromise in shield is included.

B. Drawings and Plans

1. General

- a. A table listing filters is included in drawings giving size, type, rating, location, and other pertinent details.
- b. A table listing penetrations, their locations, and their usage (ventilation, power, water, etc.) is included in the drawings. The table will reference penetration details.
- c. A wiring diagram is included in the drawings which includes location of filters and filter identification noted on the filter table referenced.

2. Details

- a. Details of filter attachment/mounting to shield are included showing all views.
- b. Details of filter enclosures are included.
- c. Details of shield seams and wall cuts showing the shield attachment to structural beams/support are included.
- d. Details of the grounding method are included.

Figure 11-2. Checklist for HEMP drawings. (sheet 2 of 3)

EP 1110-3-2
31 Dec 90

- e. All penetrations should reference a detail showing exactly how the penetration is treated.
- f. Attachment to the floor and roof to the wall shield is shown in detail.
- g. Expansion devices are shown in detail.
- h. Doors are shown in detail. Subdetails such as frame, closure, handle mechanism, threshold and others are shown clearly.

3. Penetrations

- a. Filters are shown clearly by some notation system (F1, F2, etc.).
- b. The RF shield is shown clearly on all drawings.
- c. A method for filter repair bypass is available (breakers) where applicable.
- d. The grounding system is shown clearly and is proper for the protection method.
- e. Conduits are identified and specified properly for the protection system.
- f. All access panels to shield are shown in detail and clearly identified.
- g. Where applicable, a built-in testing system is shown clearly on the drawings, including the proper details of attachment.

Figure 11-2. Checklist for HEMP drawings. (sheet 3 of 3)

CHAPTER 12

TEMPEST-SHIELDED FACILITIES

12-1. Outline. This chapter is organized as follows:

- 12-1. Outline
- 12-2. Introduction
 - a. Primary emphasis
 - b. Combining with EMP protection
- 12-3. Design criteria for 50-decibel facilities
 - a. TEMPEST-only applications
 - b. Personnel entryway
 - c. Emergency exits
 - d. Mechanical penetrations
 - e. Electrical penetrations
 - f. RED and BLACK
- 12-4. RF shield design for 50-decibel facilities
 - a. Defining the shielded volume
 - (1) Limiting extent
 - (2) Efficient floor plan
 - b. Shielding materials and joining methods
 - (1) Small and large volumes
 - (2) Modular shielded enclosure
 - (3) Materials
 - (4) Operating life
 - c. Design of modular shielded enclosures
 - (1) Purchased shields
 - (2) Shield performance
 - (3) Manufactured panels
 - (4) Screen enclosures
 - (5) Penetration panel
 - (6) On-site assembly
 - (7) Specifying shields
 - (8) Shield subassemblies
 - d. Foil shield construction
 - (1) Foil shields
 - (2) Thick sheet metal
 - (3) Installation costs
 - (4) Absence of data
 - (5) Floor shield design
 - (6) Wall and ceiling shield design
 - e. Shield quality assurance during construction
- 12-5. Penetration protection devices
 - a. 50-decibel vs 100-decibel
 - (1) Aspect
 - (2) Filter insertion loss

EP 1110-3-2
31 Dec 90

(3) *Joint treatment*

(4) *Pipes and conduits*

(5) *Electrical surge arresters*

b. *Penetration through plates*

c. *Shield doors*

d. *Specifying insertion loss*

12-6. *Cited references*

12-7. *Uncited reference*

12-2. Introduction. This chapter concerns the design and construction of ground-based facilities that require TEMPEST protection in accordance with NSA 73-2A (ref 12-1).

a. Primary emphasis. This chapter addresses facilities that have been specified for 50-decibel (nominal) TEMPEST shielding and penetration protection only.

b. Combining with EMP protection. Because of either the robust nature of the particular equipment that needs protection or a lower allowable hardening confidence level, HEMP protection with 50-decibel (nominal) electromagnetic isolation might be appropriate in selected cases. When this is true, the guidance provided in previous chapters generally will be applicable but may be relaxed. Additional protective features, particularly transient suppression devices for electrical wiring penetrations, may be necessary. Different criteria must be used in choosing the volume to be shielded.

12-3. Design criteria for 50-decibel facilities. There are no fundamental differences in the principles and technical approach between 100-decibel (nominal) shielding and penetration protection and the 50-decibel (nominal) isolation subsystem; only the required performance and implementation practice change. It is still necessary to not only provide an electromagnetic shield on a closed topological surface around the RED equipment area, but also to protect each penetration properly. Special cases, if any, must be identified and treated; RED/BLACK isolation practices must be followed within the shielded volume. Because the required effectiveness in linear (not decibel) units is lower by a factor of about 300, less expensive components and assembly techniques can be used.

a. TEMPEST-only applications. In TEMPEST-only applications, effectiveness requirements for the RF shield are fully defined by calculations performed in accordance with instructions in NACSEM (ref 12-2) or by the attenuation versus frequency curve of figure 8-4 for reasonable worst-case assumptions at CONUS locations. The rest of this chapter assumes that the 50-decibel (nominal) requirement of NSA 73-2A and figure 8-4 applies.

b. Personnel entryway. The main personnel entryway is to be a two-door shielded vestibule. The effectiveness requirements for the vestibule shield and doors are the same as those for the primary shield (fig 8-4). A principal argument in favor of a waveguide tunnel entrance was the difficulty in

EP 1110-3-2
31 Dec 90

maintaining performance of high-quality shielded doors; therefore, this more costly arrangement is not justified and is not recommended in 50-decibel (nominal) applications.

c. Emergency exits. Where entrances will be used seldom or at irregular intervals, such as emergency exits or equipment accesses, single-shielded doors that meet the attenuation of figure 8-4 should be used.

d. Mechanical penetrations. Piping and ventilation penetrations are to be protected by waveguide-beyond-cutoff techniques so as to preserve the performance of the primary shield. Based on TEMPEST attenuation requirements, the maximum dimension of the waveguide is 10.2 centimeters for 1 gigahertz and 1.0 centimeter for 10 gigahertz. Waveguide length can be reduced to three times the transverse dimension to obtain 50 decibels attenuation. Dielectric breaks are required in these TEMPEST-only applications.

e. Electrical penetrations. Power, telephone, and other audiofrequency electrical circuits that penetrate the primary shield are to be protected by filter assemblies. Electrical surge arresters are not required for TEMPEST protection but may be desirable for lightning or power line transient suppression. The filters must provide at least 50 decibel insertion loss from 14 kilohertz to the specified highest frequency, measured in accordance with MIL-STD-220A test procedures (ref 12-3). Appropriate penetration protection devices must also be provided for penetrating electrical wires with nominal operating signals in the protection range.

f. RED and BLACK. The shielded volume should contain only RED equipment; however, it is seldom possible to completely exclude BLACK circuits. The RED/BLACK isolation guidelines of NACSIM 5203 must therefore be followed (ref 12-4).

12-4. RF shield design for 50-decibel facilities.

a. Defining the shielded volume. Communication security interests will be best served and the most cost-effective TEMPEST design will be achieved by limiting the extent of the shielded volume to the minimum size needed for protection of the RED equipment. This objective is the major conceptual difference from a HEMP-hardened design, for which the preferred practice is to enclose as much mission-critical equipment as possible.

(1) Limiting extent. The cost of the shielding and penetration protection subsystem can be most strongly influenced during the layout of the facility floor plan. The RED equipment to be shielded should be concentrated into a single, minimum-size area consistent with system growth requirements. BLACK equipment should be placed in a physically separate location rather than intermixed with the RED hardware. This layout will enhance TEMPEST performance by minimizing the potential for cross-coupling of classified data into BLACK circuits. The cost of electromagnetic protection will also be reduced as follows:

EP 1110-3-2
31 Dec 90

(a) The size of the shielded volume will be minimized (shielding costs are approximately proportional to the shield surface area).

(b) A relatively small number of shield penetrations and penetration protection devices will be required.

(c) Costs for implementing the RED/BLACK isolation will be reduced.

(2) Efficient floor plan. In summary, it is seldom necessary to shield an entire facility for communications security alone. Assistance from the procuring agency and/or using organization should be obtained to create an efficient floor plan such as that shown in figure 12-1. When a large fraction of the building volume must be protected, exceptions will occur; however, this case will be unusual.

b. Shielding materials and joining methods. For high-level 100-decibel (nominal) attenuation of radiated electromagnetic fields, a continuously welded 10-gauge steel liner integrated into the facility structural design is the preferred approach. For installations that require only 50-decibel (nominal) TEMPEST isolation, however, less expensive shielding techniques are available for consideration.

(1) Small and large volumes. The most cost-effective shielding solution will depend on the type of system to be protected. Small- and large-volume cases can be identified as--

(a) Small volumes are shielded enclosures that do not require integration of the shield into the overall facility structure.

(b) Large volumes are shielded areas that occupy a major fraction of the facility and probably require integration into the structural design.

(2) Modular shielded enclosure. If the hardware to be shielded can be collected into a relatively small RED Equipment Area (REA), as shown in figure 12-1, the easiest, most cost-effective shielding approach is to install a free-standing manufactured modular shielded enclosure. This eliminates design complexity because the shield and structural designs are nearly independent, and also greatly simplifies construction. Cost savings accrue from these simplifications.

(3) Materials. When very large volumes must be shielded, it becomes cost-effective to integrate the shield into the overall design for the floors, walls, and ceilings. In these cases, the shield can be constructed using either thin (22- to 26-gauge) galvanized steel or copper sheets, or copper or stainless steel foils. A design solution is, in fact, a combination of these methods--galvanized steel sheets for the floor shield and copper or stainless steel foils for the walls and ceilings. The seams are RF-sealed with bolted

straps, special metallic tapes having conductive adhesives, or solder (for copper foils).

(4) Operating life. The sparse amount of life-cycle data on the performance of modular shielded enclosures suggest that 50-decibel (nominal) attenuation can be sustained for many years with a reasonable maintenance program. The data are unfavorable for 100-decibel (nominal) applications. However, while shielding vendors claim long life for foil shields, no well documented published data have been found to support this assertion. Still, it should be possible to maintain a foil shield at the nominal 50-decibel level during the operating life. To do this, easy access for inspection of the foil should be designed into the facility.

c. Design of modular shielded enclosures. Modular shielded enclosures in sizes up to about 93 square meters of floor area are commercially available from the standard product lines of numerous shielding suppliers. Prices for these enclosures vary with the dimensions of the room and the number and type of penetration panels. Typical figures at 1985 price levels are about \$28/square foot (total shield surface area), or \$90/square foot of floor area. These amounts include the cost of doors.

(1) Purchased shields. Custom-designed, modular shielded enclosures of larger size can also be purchased. The special design aspects are mainly structural in nature and can increase the cost per unit area as much as 40 percent.

(2) Shield performance. Nearly all of the modular shielded enclosures in today's market are designed to comply with the shielding effectiveness requirements of NSA 65-6 (ref 12-5) and will initially provide 100 decibels (nominal) performance. The sparse amount of data on life-cycle attenuation indicate the performance may quickly drop below the 100-decibel level, but (with the possible exception of the doors) should remain above the 50-decibel (nominal) requirement for many years with a program of reasonable maintenance.

(3) Manufactured panels. A shielded enclosure is typically assembled from premanufactured panels made of plywood, masonite, rigid foam, or a similar filler and clad with 22- to 26-gauge galvanized steel sheets. A dimensionally stable filler is required to preserve shielding effectiveness, so that plywood is somewhat suspect in this regard. Seams between adjacent panels generally cannot be welded because of the thin metal sheets and the heating effects on the filler material. Clamped joints, such as those shown in figure 12-2, are most common.

(4) Screen enclosures. Modular screen enclosures that satisfy these shielding effectiveness requirements are also available as standard commercial products. The panels are made of 8 to 10 wire/centimeter copper, bronze, or other metallic screen which is placed on both the inner and outer surfaces of a wooden frame. Normally, electrical isolation between the two screens is maintained. The panels bolt together to form the enclosure. The main

EP 1110-3-2
31 Dec 90

advantages of screen enclosures are simplified ventilation requirements and light weight. The most serious problems are the fragility of the screen and the unrestricted light and sound passage through the walls. The latter problem implies that physical controls and personnel security clearance/need-to-know requirements in areas around the shield should be the same as those required within the shielded volume.

(5) Penetration panel. Figure 12-3 shows a typical installation for a penetration panel. As can be seen in this figure, it is the outer sheet of a panel that is usually employed for the continuous electromagnetic barrier. However, whether the inner or outer sheet is chosen to be the shield is not important as long as the surface selected is topologically maintained.

(6) On-site assembly. On-site assembly of the prefabricated elements can be completed in a relatively short period of time.

(7) Specifying shields. During the design and construction phases, a modular shielded enclosure can be treated essentially as an off-the-shelf commercial product. However, while detailed drawings are not required, the design must explicitly and carefully specify essential characteristics and quality assurance provisions, including the following:

(a) For proper shielding effectiveness, it is recommended that the manufacturer's advertised design attenuation be specified when it exceeds 50 decibels, rather than using the shielding effectiveness-versus-frequency curve shown in figure 8-4. This will allow a large margin for in-service degradation without incurring a significant cost penalty.

(b) The overall length, width, and height of the shielded enclosure shall be listed in the specifications.

(c) The requirement for and location of the vestibule entrance shall be specified. It should be stated explicitly that the shielding effectiveness requirement applies when one vestibule door is open and the other door closed.

(d) The size and location of other shielded doors shall be listed in the specifications.

(e) The number, size, and location of penetration panels shall be listed on the construction drawings.

(f) Detailed shop drawings shall be used by the prime construction contractor when installing all interfaces to the shield.

(g) Immediately after the shielding vendor completes the installation, testing for compliance with the shielding effectiveness requirement shall be performed. The NSA 73-2A shielding effectiveness measurement procedures shall be used.

(8) Shield subassemblies. This discussion has dealt only with the shielding, shield doors, and blank penetration panels. Virtually all shielding vendors can also provide finished piping, ventilation, and filter (ESA, if required) assembly penetration panels. These subjects will be addressed later in this chapter for 50-decibel (nominal) applications. Furthermore, most modular shield enclosure vendors can provide much of the installation work unrelated to the shielding and penetration protection performance. (This information is provided only for the convenience of designers, as the support subsystems are not areas of interest in this manual.) Examples include the following:

- (a) Interior finishing, including raised flooring, suspended ceilings, and interior partitions.
- (b) Interior electrical distribution subsystems.
- (c) Interior lighting subsystems.
- (d) Interior heating, ventilation, and air-conditioning (HVAC) subsystems.
- (e) Interior hangers and supports that do not create shield penetrations.

d. Shield construction. Two methods of shield construction are addressed in this paragraph.

(1) Foil shields. The first method uses stainless steel foil, from 0.05 millimeter to 0.2 millimeter thick, or copper foil, from 0.1 millimeter to 0.2 millimeter thick, to form the electromagnetic barrier. The foils can be applied to wallboard using a standard adhesive similar to installing wallpaper or other supporting material using nails/staples. The seams are usually closed by overlapping the foils, clamping, soldering, and sealing with a special conductive tape or by using a combination of these methods. In some instances, several layers of foil are applied. Another layer of wallboard is normally used as an overlay material to protect the fragile shielding material.

(a) Recent developments in foil shield technology include foils that are actually paper with impregnated fibers to improve tear resistance; solder-backed copper tape to which heat can be applied when used to tape a seam of a copper foil shield to form a joint of very low resistivity; and tin-plated copper tape that is used to reduce corrosion and improve compatibility between dissimilar metals.

(b) Copper-clad steel foils with improved low-frequency field attenuation properties are also available. Their performance greatly exceeds the requirements of this application, however. Therefore, they increase

EP 1110-3-2
31 Dec 90

shielding costs in two ways--higher material costs and increased labor because the foil is made in relatively narrow widths.

(2) Thick sheet metal. The second method of shielding construction uses a thicker sheet metal, often in the range from 22-gauge (0.75 millimeters) to 26-gauge (0.45 millimeters). The advantage of this material is reduced risk of damage from incidental contact. The sheets for a floor shield can be simply laid on a vapor barrier over a concrete slab. Sheets for a wall or ceiling shield are nailed in place. The joint between galvanized steel sheets is made by overlapping (with or without tack welds) and using conductive epoxy between sheets and/or taping over the seam. The steel sheets also can be joined using straps similar to those for clamping modular panels. Copper sheets are joined by overlapping and clamping, taping, or soldering.

(3) Installation costs. Cost figures quoted by vendors for installing foil and thin-sheet metal shields can be very deceptive and must be qualified carefully. If the general contractor provides the complete wall except for the shield material, the shielding subcontractor's material and labor costs may be as low as \$6/square foot (1985 prices) of shield surface area. Total price for construction, without the interior finish and without the doors, may be about \$20/square foot (1985 prices) of surface area.

(4) Absence of data. In the absence of a well documented data base on life-cycle performance, selection of the preferred foil/thin sheet metal shielding method is somewhat intuitive. Throughout the rest of this discussion, therefore, supporting arguments are given for the methods presented.

(5) Floor shield design. Sheet metal floor shield is recommended for most floor shield designs because of the high stresses placed on the floor shield and the extreme difficulty in effecting repairs after the facility is operational. In unusual cases, such as a temporary facility with a short useful lifetime, a foil shield floor can be used.

(a) The basic shield materials are 22- to 26-gauge galvanized steel sheets in the largest available and most convenient to handle size. Sheets to be used at the edges of the floor shield should be bent upward to form a vertical section about 10 centimeters to 20 centimeters high for interfacing with the wall shield. The sheets should be laid on a vapor barrier over the concrete floor slab so that adjacent sheets overlap by approximately 5 centimeters, as indicated in figure 12-4.

(b) Figure 12-5 shows the suggested methods for treating floor shield seams. As noted, the sheets should be secured in place with either a clamping strap or periodic tack welds. The strapping technique, which is preferred in high-humidity environments or in cases for which a wear slab is to be poured over the floor shield, uses galvanized steel bars held in place by anchor studs fired into the foundation through the sheet metal. Strapping need not be continuous, but must be sufficient to ensure good surface contact

between the sheets. Under less corrosive conditions, periodic tack welds can be used for this purpose. The accessible seam is then taped continuously with stainless steel or tin-plated copper tape that has a conductive adhesive.

(c) If a wear slab is to be poured, a second vapor barrier will be laid over the floor shield. The height of the vertical lip at the floor/wall interface will be chosen to allow at least 7.5 centimeters above the top of the slab.

(6) Wall and ceiling shield design. A copper or stainless steel foil shield (or sheet metal shield similar in design to the floor) is recommended for use with wall and ceiling shield design and construction. Aluminum foils are also available but should not be used because of the potential for surface oxidation. Foils backed by paper with impregnated fibers are preferred over bare foils because of improved resistance to tearing.

(a) The wallboard area to be shielded should be flat and free of protrusions. Careful measurements should be taken and a section of foil should be precut and test-fitted before applying the adhesive. The adhesive should then be trowled onto the wallboard and the foil should be installed in the same way as wallpaper is hung. The sheet should then be worked and smoothed to eliminate air bubbles and wrinkles.

(b) As an alternative, the foil can be installed by stapling or nailing to the wallboard or studs. If this technique is used, the head of the nail or staple should be covered by overlapping foil or tape. Long-term reliability of stapled or nailed foil should be considered questionable.

(c) Bare foils should be overlapped by approximately 5 centimeters; foils which are nonconductively backed (e.g., with paper backing) should be butted rather than overlapped. Seams should then be taped with a compatible metal tape having a conductive adhesive. Copper foil seams should be RF sealed using the solder-coated tape (figs 12-6 through 12-8).

(d) In two areas--at the wall/floor shield joint and at penetration points--the foil shield must interface with the galvanized steel plate. Seams in these locations should be formed as shown in figure 12-8. When copper foil has been used, the overlap area of the steel plate should first be covered with a tin-plated copper tape having conductive adhesive to reduce the potential for galvanic action. The joint should then be clamped and taped as shown.

(e) A second wallboard should then be installed to protect the fragile shielding material.

(f) Foil shields are particularly susceptible to damage when mounting equipment or installing the interior finish because the shield layer offers no resistance to nails and screws. Extreme care must be exercised during both construction and operation to avoid unintentional shield

EP 1110-3-2
31 Dec 90

penetrations. This fact shall be emphasized strongly in the shield maintenance procedures.

e. Shield quality assurance during construction. The need for quality assurance during construction of a 50-decibel shielded facility is the same as that described for construction of a welded steel shield. A shielded enclosure leak detection system (SELDs) checking program is to be used during assembly and NSA 73-2A SE testing shall be used for acceptance. Two NSA 73-2A tests shall be performed. Preliminary measurements shall be made immediately after the RF shield has been closed to avoid costly repairs later and attendant schedule delays. After all equipment and finishes are in place and all other work with the potential to affect shield performance has been completed, the final acceptance test shall be performed.

12-5. Penetration protection devices.

a. 50-decibel vs 100-decibel. Designs for penetration protection devices (PPDs) to be used in 50-decibel (nominal) TEMPEST-only shielded facilities are very nearly the same as those for 100-decibel (nominal) HEMP/TEMPEST shielded buildings. The major differences are performance requirements and the fact that the shield is structurally much weaker and, therefore, the support for the penetration panels must be provided by other mechanical elements. Additional variations include the following:

(1) Aspect. The aspect (minimum length to maximum transverse dimension) ratio for waveguide-beyond-cutoff piping and ventilation penetration protection can be reduced to 3:1.

(2) Filter insertion loss. The filter insertion loss requirements are lower.

(3) Joint treatment. Overlapped, clamped, and taped joints are permitted as described in the preceding paragraph while 100-decibel (nominal) performance demands circumferential welds between the penetration panel and bulk shield.

(4) Pipes and conduits. Pipe and conduit penetrations can be made with compression fittings and threaded joints rather than circumferential welds.

(5) Electrical surge arresters. ESAs are not required on electrical penetrations.

b. Penetrations through plates. The penetrations should be made through heavy galvanized steel panels, which serve the dual function of spreading the surface currents and simplifying the interface to the bulk shield. The approach for a piping penetration is shown in figure 12-9. Honeycomb panel and conduit penetrations are done using a similar method. For rigidity, the penetration plate will be from 6.2 millimeters to 12.5 millimeters thick and

EP 1110-3-2
31 Dec 90

will have a clear area of about 15.2 centimeters wide around the periphery for interfacing with the bulk foil shield.

c. Shield doors. Knife-edge or magnetically sealed shield doors and frames shall be used for continuously attended enclosures rather than designs with exposed contact fingers to avoid accidental damage to the RF seal.

d. Specifying insertion loss. One final word of caution is appropriate. An insertion loss of 50 decibels can generally be expected with single-stage (three-element) filters, and these devices can have far more drastic performance variations with changes in the load impedance than three-stage (seven-element) 100-decibel (nominal) filters. It is recommended, therefore, that insertion loss be specified and measured over the range of load impedances that will be experienced during nominal operation.

12-6. Cited references.

- 12-1. National Security Agency (NSA) Specification No. 73-2A, Specification for Foil RF Shielded Enclosure (NSA, 15 November 1972).
- 12-2. National COMSEC/EMSEC Information Memorandum (NACSEM) 5204, (U) Shielded Enclosures (NSA, January 1979) (C).
- 12-3. Military Standard (MIL-STD) 220A, Method of Insertion-Loss Measurement (Department of Defense [DOD], 15 December 1959).
- 12-4. NACSIM 5203, (U) Guidelines for Facility Design and RED/BLACK Installation (NSA, 30 June 1982) (C).
- 12-5. NSA Specification No. 65-6, Specification for RF Shielded Enclosures for Communications Equipment: General Specification (NSA, 30 October 1964).

12-6. Uncited reference.

National COMSEC Information Memorandum (NACSIM) 5100A (U) Compromising Emanations Laboratory Test Requirements, Electromagnetics (NSA) (C).

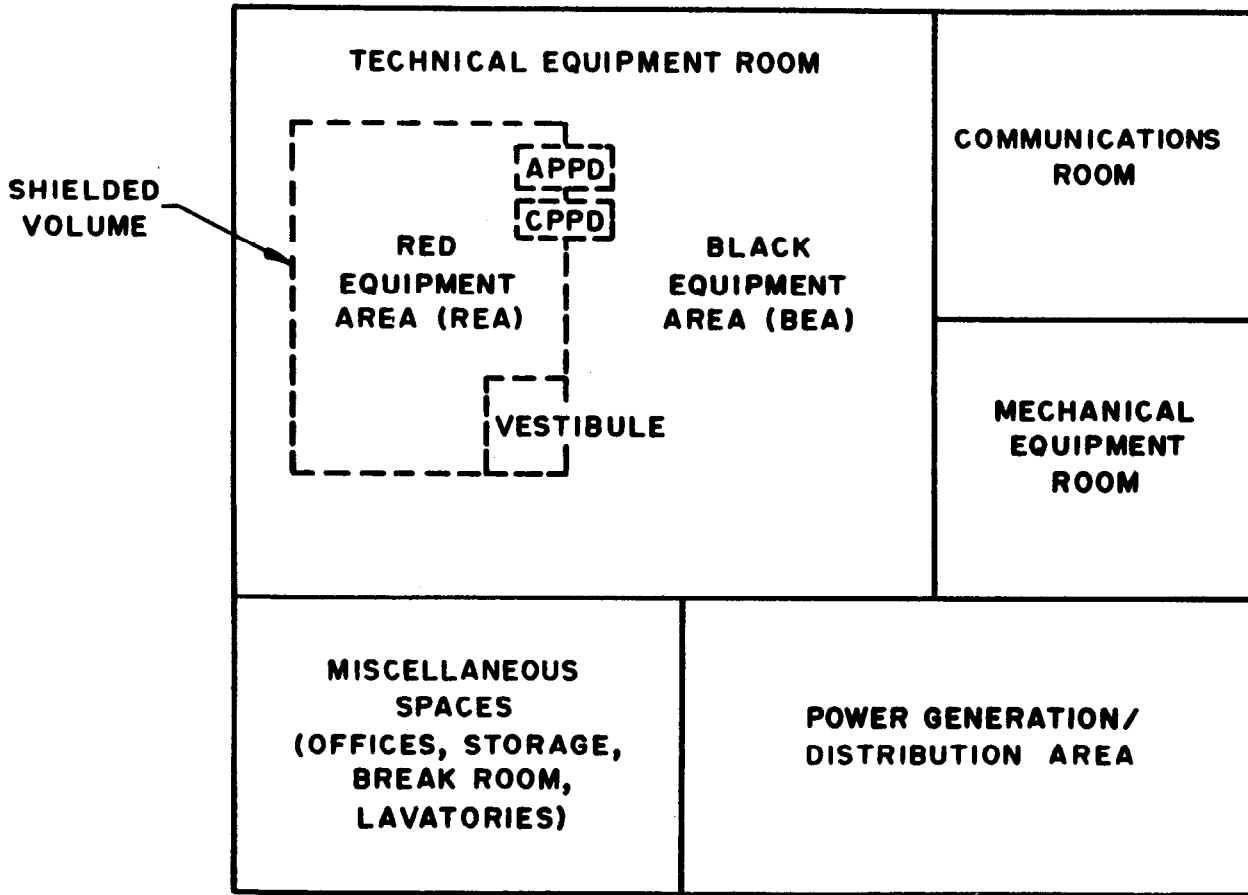


Figure 12-1. Efficient TEMPEST facility floor plan.

EP 1110-3-2
31 Dec 90

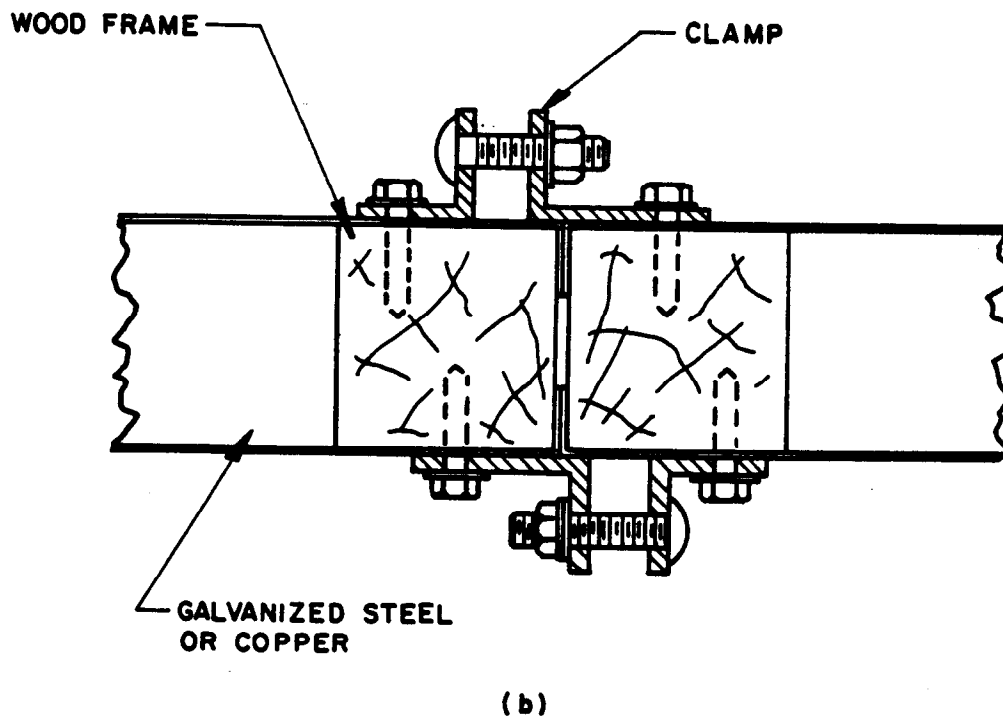
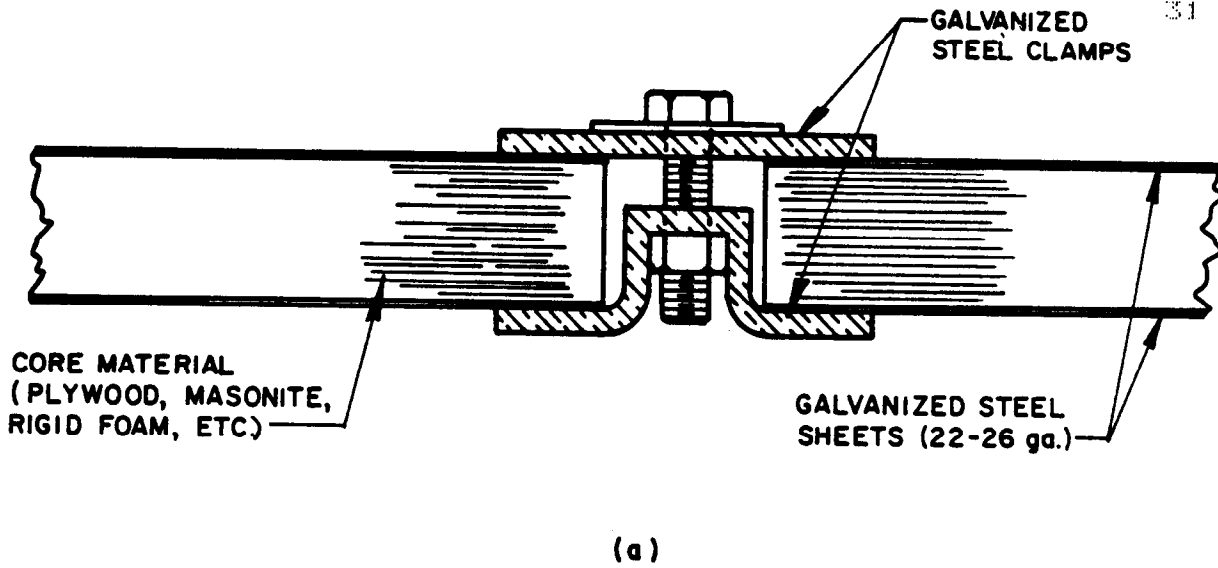


Figure 12-2. Typical clamped modular shield room joints.

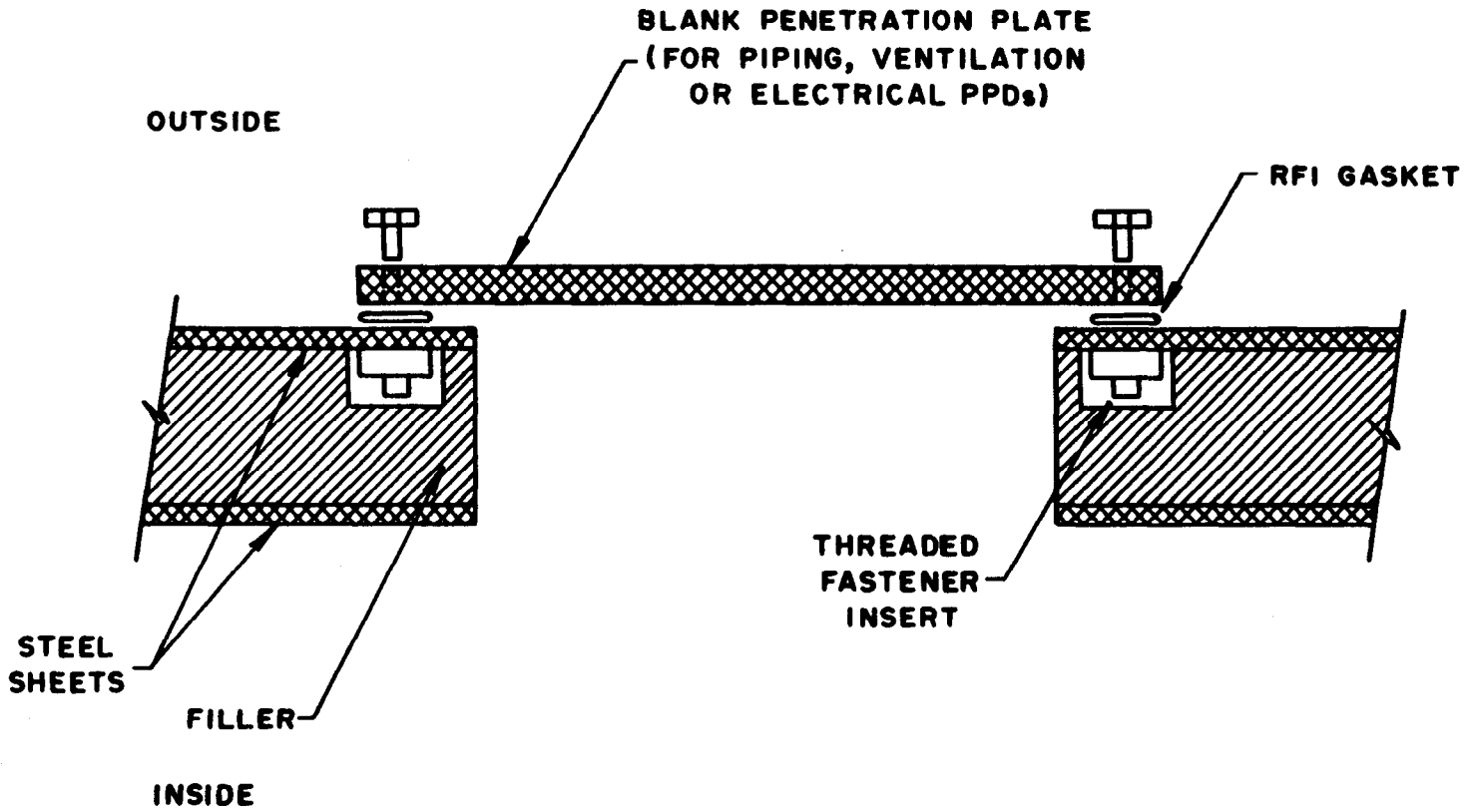


Figure 12-3. Typical penetration panel installation in a modular shielded enclosure.

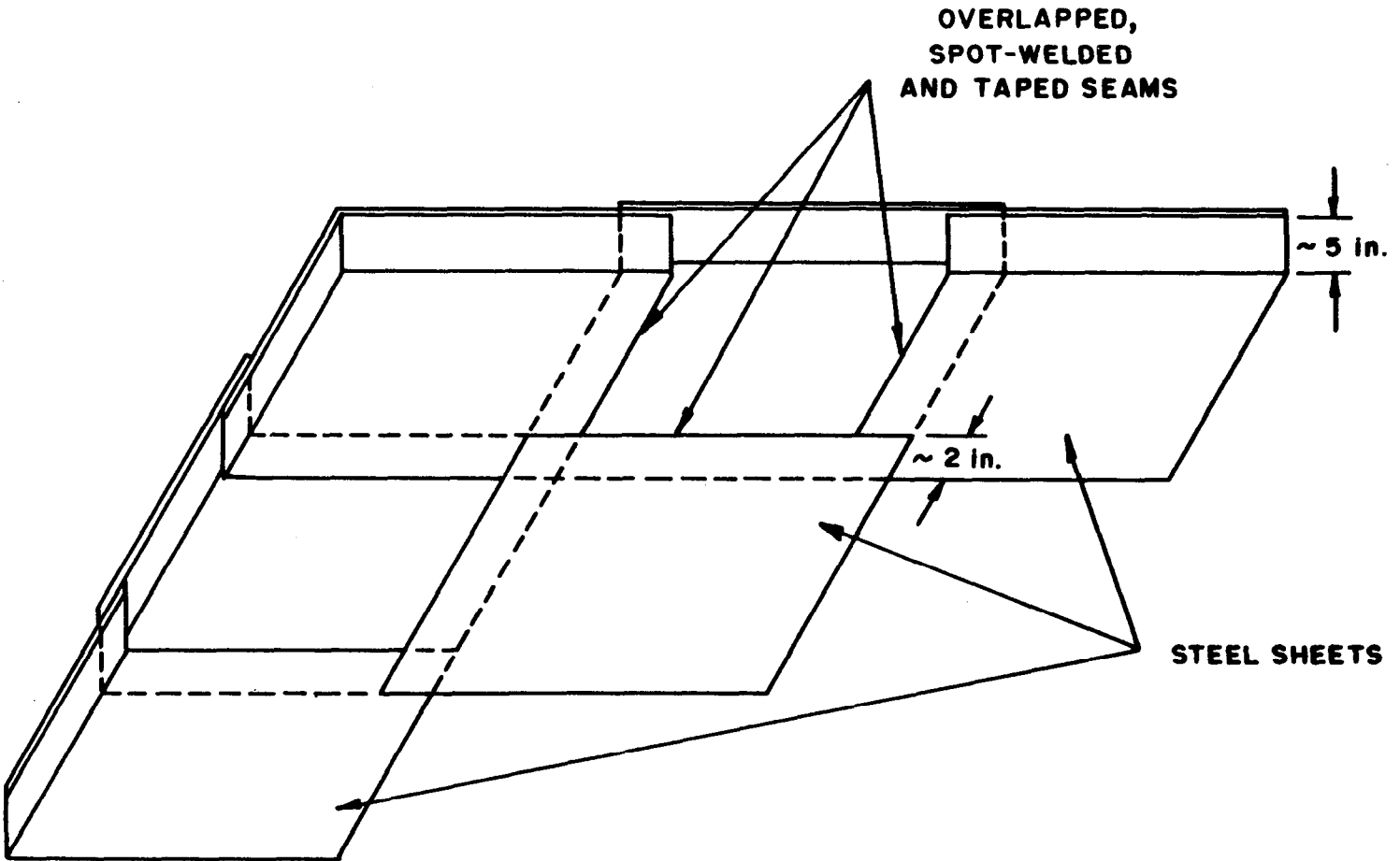


Figure 12-4. Steel plate floor shield design.

12-15

EP 1110-3-2
31 Dec 90

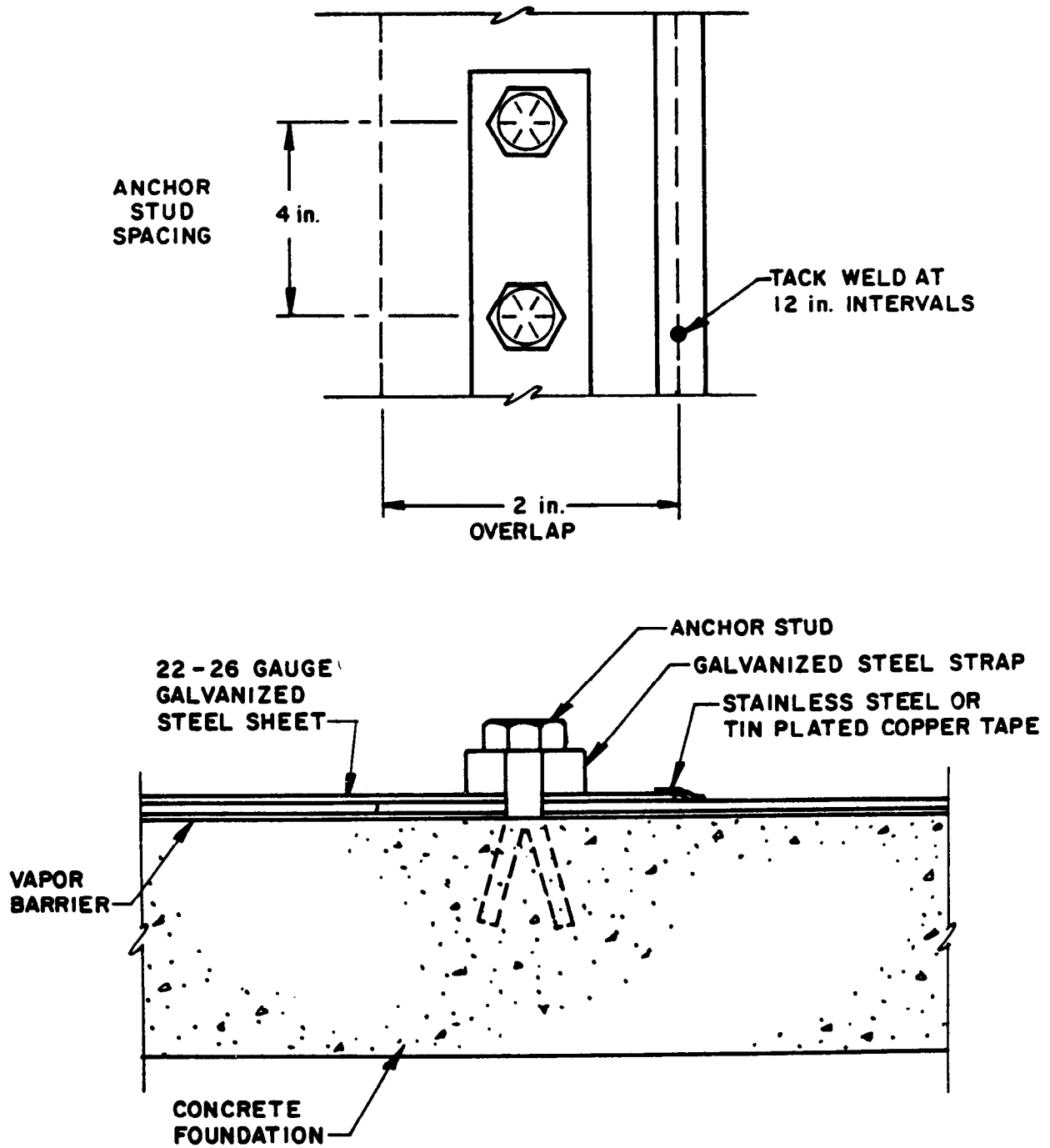


Figure 12-5. Floor plate shield construction technique.

EP 1110-3-2
31 Dec 90

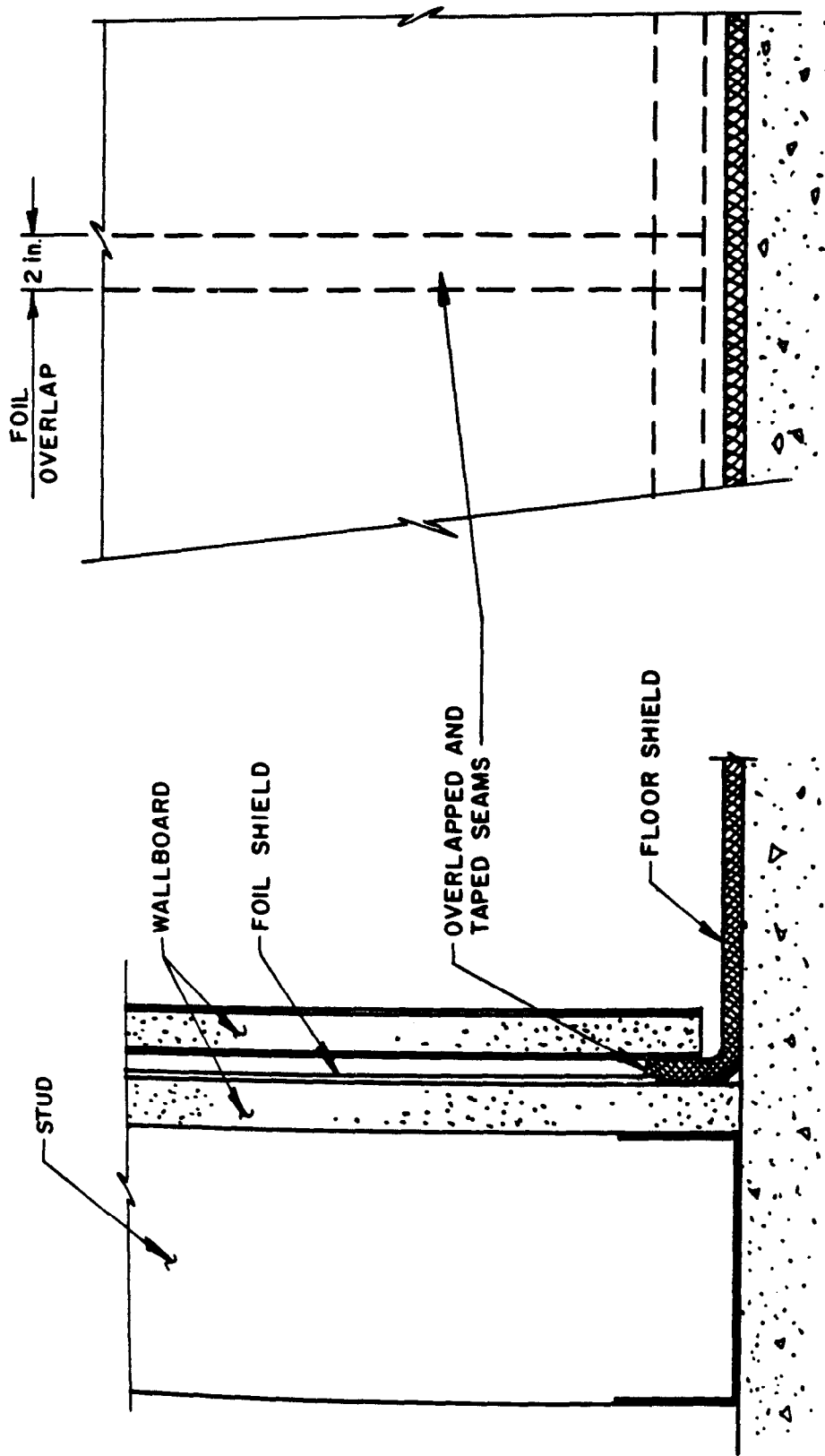


Figure 12-6. Foil wall shield construction technique.

EP 1110-3-2
31 Dec 90

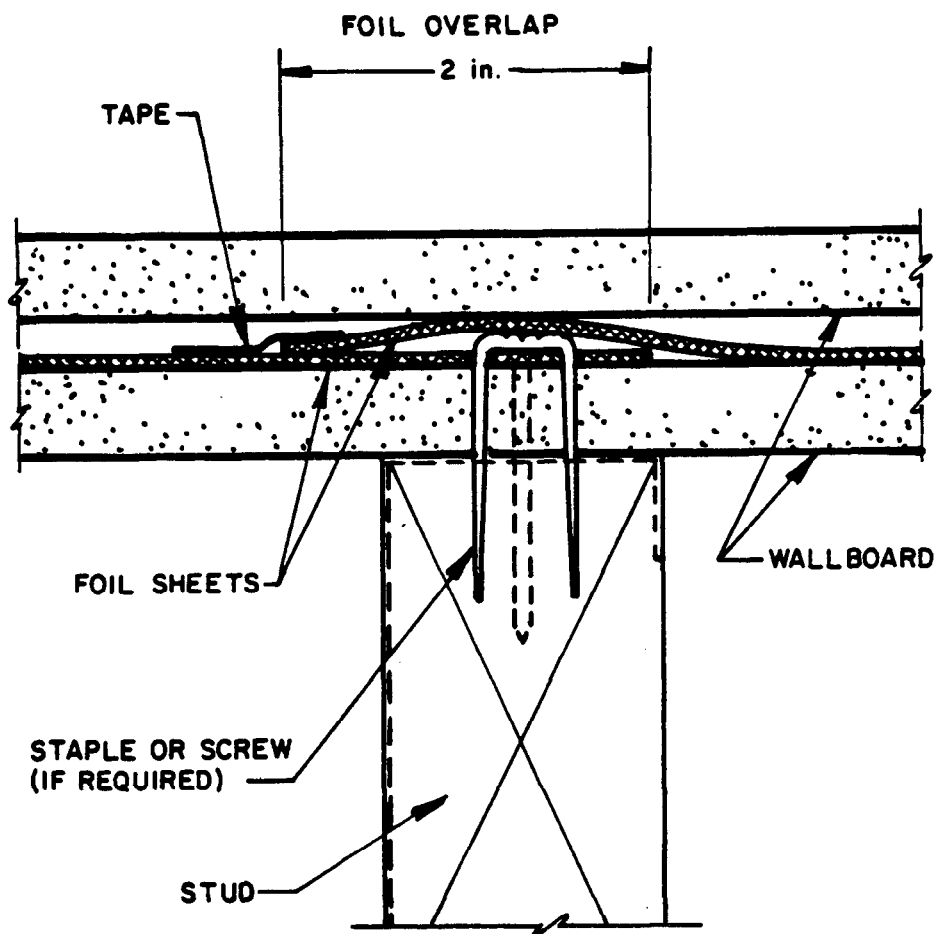


Figure 12-7. Foil/foil seam.

EP 1110-3-2
31 Dec 90

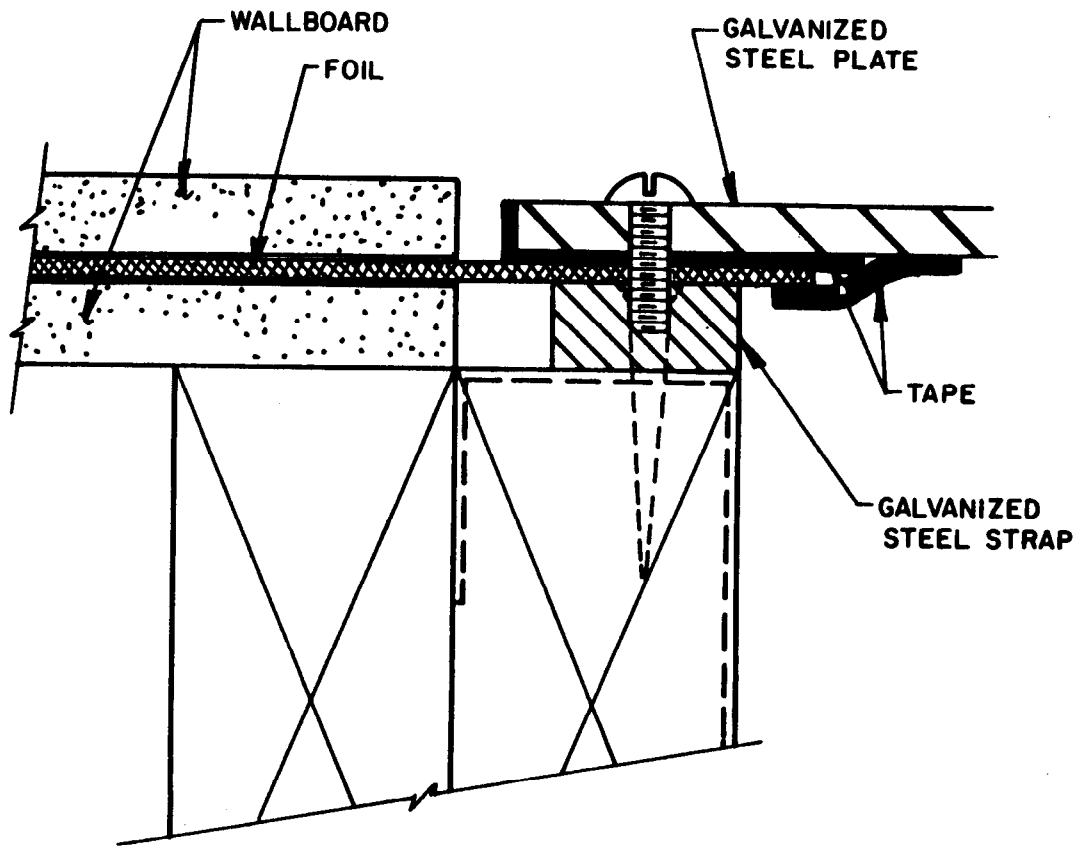
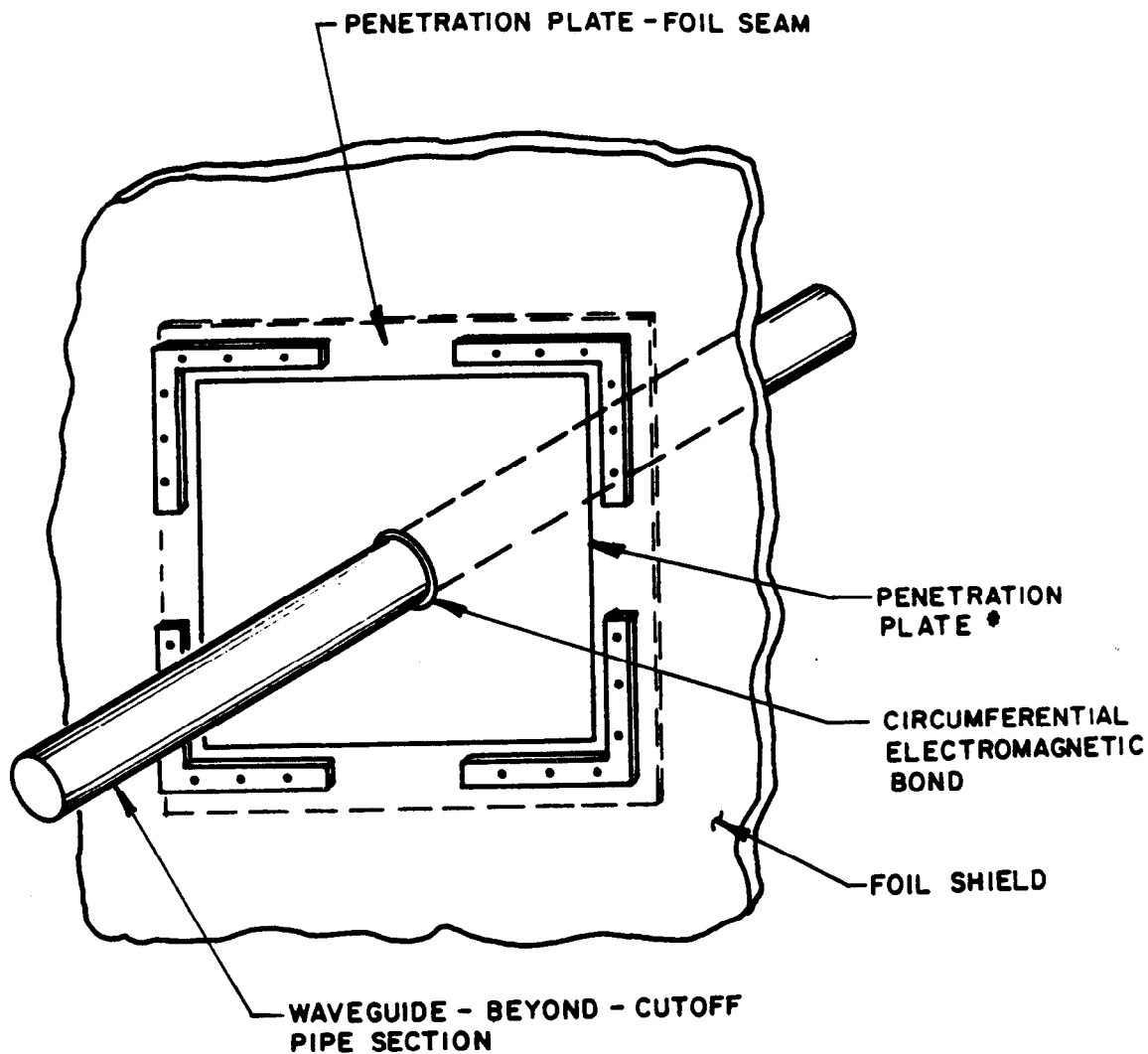


Figure 12-8. Sheet metal/foil seam.

EP 1110-3-2
31 Dec 90



♦ PROVIDE SUPPORT FOR PENETRATION PLATE AND PIPING FOR MECHANICAL PROTECTION OF THE SHIELD.

Figure 12-9. Foil shield pipe penetration design.